

PowerEdge R210 II



Technical Guide



The PowerEdge R210 II offers performance, energy efficiency and ease of management for businesses of all sizes.

This document is for informational purposes only. Dell reserves the right to make changes without further notice to any products herein. The content provided is as is and without express or implied warranties of any kind.

Dell, PowerEdge, and ReadyRails are trademarks of Dell, Inc. Citrix is a registered trademark and XenServer is a trademark of Citrix Systems, Inc. and/or one or more of its subsidiaries, and may be registered in the United States Patent and Trademark Office and in other countries. Intel, Xeon, Celeron, and Pentium are registered trademarks and Core is a trademark of Intel Corporation in the U.S. and other countries. Broadcom is a registered trademark and NetXtreme is a trademark of Broadcom Corporation and/or its affiliates in the United States, certain other countries and/or the EU. Matrox is a registered trademark of Matrox Electronic Systems Ltd. Microsoft and SQL Server are either registered trademarks or trademarks of Microsoft Corporation in the United States and/or other countries. Red Hat is a registered trademark of Red Hat, Inc. in the United States and other countries. Linux is a registered trademark of Linus Torvalds. Symantec is a trademark owned by Symantec Corporation or its affiliates in the U.S. and other countries. VMware is a registered trademark and vSphere is a trademark of VMware, Inc. in the United States and/or other jurisdictions. Insyde is a registered trademark of Insyde Software. Other trademarks and trade names may be used in this document to refer to either the entities claiming the marks and names or their products. Dell disclaims proprietary interest in the marks and names of others.

©Copyright 2011 Dell Inc. All rights reserved. Reproduction or translation of any part of this work beyond that permitted by U.S. copyright laws without the written permission of Dell Inc. is unlawful and strictly forbidden.

June 2011

Table of Contents

1	Product Comparison	7
1.1	Overview	7
1.2	Key Benefits	7
1.3	Flexible, Secure Technology.....	7
1.4	Easy to Manage	8
1.5	Comparison	8
2	New Technologies.....	10
3	System Overview.....	11
4	Mechanical	13
4.1	Chassis Description.....	13
4.2	Dimensions and Weight.....	13
4.3	Front Panel View and Features	14
4.4	Back Panel View and Features	14
4.5	Power Button LED	14
4.6	System Status ID.....	15
4.7	NIC Indicators.....	15
4.8	Internal Chassis Views	15
4.9	Rails.....	16
4.9.1	ReadyRails Static Rails	16
4.10	Fans	16
4.11	LED Control Panel.....	17
4.12	Security.....	17
4.12.1	Cover Latch	17
4.12.2	Bezel	17
4.12.3	Hard Drive.....	17
4.12.4	Trusted Platform Module (TPM).....	17
4.12.5	Power Switch Security.....	18
4.12.6	Intrusion Alert	18
4.12.7	Secure Mode	18
4.13	USB Key.....	18
4.14	Battery.....	18
4.14.1	Field Replaceable Units (FRU).....	18
4.15	User Accessible Jumpers, Sockets, and Connectors.....	18
5	Power, Thermal, Acoustic	19
5.1	Power Supplies	19
5.2	Power Supply Specifications.....	19
5.3	Heat Dissipation	19
5.4	Environmental Specifications.....	20
5.5	ENERGY STAR Compliance	21
5.6	Thermal.....	21
5.7	Acoustics	21
6	Processors	24
6.1	Overview	24
6.2	Features	24
6.3	Supported Processors.....	24
6.4	Processor Configurations.....	25
6.5	Processor Installation.....	25
7	Memory	26

Dell

7.1	Overview	26
7.2	DIMMs Supported	26
7.3	DIMM Slots	26
7.4	Speed	26
7.5	Sparing.....	27
7.6	Mirroring.....	27
7.7	RAID	27
7.8	Supported Configurations	27
8	Chipset	28
8.1	Overview	28
8.2	Direct Media Interface	28
8.3	PCI Express Interface	28
8.4	SATA Interface.....	28
8.5	AHCI.....	28
8.6	PCI Interface	28
8.7	Low Pin Count (LPC) Interface	28
8.8	Serial Peripheral Interface (SPI)	28
8.9	Compatibility Module	29
8.10	Advanced Programmable Interrupt Controller (APIC).....	29
8.11	USB Interface	29
8.12	Real-Time Clock (RTC)	29
8.13	GPIO.....	30
8.14	Enhanced Power Management.....	30
8.15	System Management Features.....	30
8.15.1	TCO Timer	30
8.15.2	Processor Present Indicator.....	30
8.15.3	Error Code Correction (ECC) Reporting	30
8.15.4	Function Disable.....	30
8.15.5	Intruder Detect	30
8.16	System Management Bus (SMBus 2.0)	31
8.17	Intel Virtualization Technology for Directed I/O	31
9	BIOS	32
9.1	Overview	32
9.2	Supported ACPI States.....	33
9.2.1	Power Management Modes	33
10	Embedded NICs/LAN on Motherboard (LOM)	36
10.1	Overview	36
10.2	Features	36
11	PCI Slots	37
11.1	Overview	37
11.2	Quantities and Priorities	37
11.3	PCI Card Dimensions	37
12	Storage	38
12.1	Overview	38
12.2	Hard Drives.....	38
12.3	RAID Configurations.....	38
12.4	Optical Drives.....	39
12.5	Tape Drives	39
13	Video.....	40
14	Rack Information.....	41
14.1	Overview	41

Dell

14.2	Rails	41
14.3	Cable Management Arm (CMA)	42
14.4	Rack View	42
15	Operating Systems	44
16	Systems Management	45
16.1	Overview	45
16.2	Server Management	45
16.3	Embedded Server Management	46
16.4	Dell Lifecycle Controller and Unified Server Configurator	46
16.5	Integrated Dell Remote Access Controller	47
16.6	iDRAC6 Express	47
16.7	iDRAC6 Enterprise	47
16.8	iDRAC6 Enterprise with Virtual Flash (vflash) Media	47
17	Peripherals	50
Appendix A.	Statement of Volatility	51
Appendix B.	Certifications	54
B 1.	Regulatory Certifications	54
B 2.	Product Safety Certifications	54
B 3.	Electromagnetic Compatibility	55
B 4.	Ergonomics, Acoustics and Hygienics	55
Appendix C.	Industry Standards	56

Tables

Table 1.	Comparison of PowerEdge R210 II to R210 and R310	8
Table 2.	Product Feature Summary	11
Table 3.	Power Supply Specifications	19
Table 4.	Environmental Specifications	20
Table 5.	Shock and Vibration Specifications	21
Table 6.	Acoustical Specifications	22
Table 7.	Supported Intel Xeon Processors	24
Table 8.	Supported Intel Desktop Processors	25
Table 9.	DIMMs Supported	26
Table 10.	Supported Configurations	27
Table 11.	Supported ACPI States	33
Table 12.	Power Management Features	34
Table 13.	Power Profiles	35
Table 14.	Supported Hard Drives	38
Table 15.	Factory RAID Configurations	38
Table 16.	Graphics Video Modes	40
Table 17.	Supported Racks	41
Table 18.	Rail Adjustability Ranges and Depth	41
Table 19.	Unified Server Configurator Features and Description	46
Table 20.	Features List for Base Management Functionality, iDRAC6, and vFlash	48
Table 21.	Volatility Table	51
Table 22.	Product Safety Certifications	54
Table 23.	Electromagnetic Compatibility Certifications	55
Table 24.	Ergonomics, Acoustics and Hygienics	55
Table 25.	Industry Standards	56

Figures

Figure 1.	Chassis Dimensions	13
Figure 2.	Front View (With Bezel).....	14
Figure 3.	Front View (Without Bezel).....	14
Figure 4.	Back View	14
Figure 5.	Power Button	15
Figure 6.	Internal Chassis View	16
Figure 7.	Front Panel View with LED Control Panel	17
Figure 8.	LED Control Panel (Detailed View)	17
Figure 9.	Formulas for Maximum Operating Temperature for Given Altitude (°C)	20
Figure 10.	Formulas for Maximum Operating Temperature for Given Altitude (°F).....	20
Figure 11.	A4 Static Rail System	42
Figure 12.	A6 Static Rail System	42
Figure 13.	A4 and A6 Rail Systems in 2-post Center-Mount Configuration	43
Figure 14.	A4 and A6 Rail Systems in 2-post Flush-Mount Configuration	43

1 Product Comparison

1.1 Overview

The PowerEdge R210 II is an entry-level, yet enterprise ready, ultra-dense 1-socket 1U rack server that is well suited for a broad range of workloads, from small businesses applications to high-density, scale-out compute farms. It offers the performance and features to run your business applications that facilitate data coordination and sharing, data protection, management, and scalability to support business growth.

With a full selection of processors to meet your performance needs, the R210 II supports the Intel® Xeon® processor E3-1200 product family, the Intel Core™ i3-2100 product family, and Intel Pentium® processors. Also included are four DIMM slots with enough memory to handle common applications, hard drive options for two 3.5" or four 2.5" (available Q2 2011) cabled hard drives for flexible internal local storage, one PCIe true x16 slot to connect a variety of peripherals, as well as the full Dell OpenManage™ suite of systems management for ease of deployment, monitoring, and ongoing maintenance.

1.2 Key Benefits

Designed for powerful and balanced performance, the PowerEdge R210 II delivers:

- **Built-in Reliability, Security and Energy Efficiency:** Built-in redundant hard drives, encryption, security and data protection options, lower wattage power supplies, and ease of deployment.
- **Business Value:** Performance headroom and capacity expansion allow the R210 II to grow as your business grows. A choice of options enables you to tailor your R210 II configuration to your compute requirements.
- **Simplified Management:** Manage the R210 II with the full suite of Dell OpenManage systems management software throughout the server lifecycle.
- **Better Performance with Less Noise:** Business performance with similar sound levels as a desktop computer to meet the needs of sound-sensitive office environments.

1.3 Flexible, Secure Technology

Securing your most valuable asset—your data—is important. That is why the PowerEdge R210 II has data protection options to help keep your data as safe as possible. Coupled with the latest version of Microsoft® Windows® Small Business Server 2011 (SBS 2011), the PowerEdge R210 II provides an integrated solution that can further protect your data by providing automatic backup and restore functionality as well as offering email, remote access, and collaboration to help take your business to the next level. The R210 II also includes lower wattage power supplies and features a built-in user interface for ease of deployment. With the PowerEdge R210 II you can:

- Protect data with hardware- and software-enabled encryption.
- Secure business information with a RAID configuration to make copies of data automatically.
- Provide email, collaboration, remote access, automatic backup, and data restore functionality with Windows SBS 2011.
- Deploy your server faster and achieve productivity sooner with optional embedded management.

1.4 Easy to Manage

The Dell PowerEdge R210 II lets you focus on running your business rather than running your servers. Dell OpenManage systems management software helps to automate common management tasks, thereby enhancing efficiency, improving productivity, and reducing the potential for error (which can cause downtime).

The optional Dell Lifecycle Controller can simplify administrator tasks by performing a complete set of functions such as system deployment, system updates, hardware configuration and diagnostics from a single intuitive interface called Unified Server Configurator in a pre-OS environment. This eliminates the need to use and maintain multiple pieces of disparate CD/DVD media. With Dell Lifecycle Controller server deployment automation, the R210 II is up and running fast.

1.5 Comparison

Table 1. Comparison of PowerEdge R210 II to R210 and R310

Feature	R210	R210 II	R310
Processor	Intel® Xeon® processor 3400 series Intel Celeron® G1101 Intel Pentium® G6950 Intel Core™ i3 processor 500 series	Intel Xeon processor E3-1200 product family, Intel Core processor i3-2100 product family	Intel Xeon processors 3400 series Intel Celeron G1101 Intel Pentium G6950 Intel Core i3 processor 500 series
Front Side Bus	Direct Media Interface (DMI) 2.5Gb/s	Direct Media Interface II (DMI) 5.0Gb/s	Direct Media Interface (DMI) 2.5Gb/s
Sockets	1	1	1
Cores	2 or 4	2 or 4	2 or 4
L2/L3 Cache	Up to 8MB	Up to 8MB	Up to 8MB
Chipset	Intel 3420	Intel C202	Intel 3420
DIMMs	4 DDR3 1066/1333MHz	4 DDR3 1333MHz	6 DDR3 1066/1333MHz
Min/Max RAM	1GB/32GB	1GB/32GB	1GB/32GB
Hard Drive Bays	2 x 3.5" or 2 x 2.5"	2 x 3.5" or 4 x 2.5" (available Q2 2011)	4 x 3.5" or 4 x 2.5" Optional hot-plug
Hard Drive Types	SATA SSD, SAS, nearline SAS, SATA	SATA SSD, SAS, nearline SAS, SATA	SATA SSD, SAS, nearline SAS, SATA
External Drive Bay	1 for slim optical disk drive (ODD)	1 for slim optical disk drive (ODD)	1 for slim optical disk drive (ODD)
Embedded Hard Drive Controller	Chipset-based SATA	Chipset-based SATA, PERC S100 (embedded SW RAID)	Intel 3420, PERC S100 (embedded SW RAID)

Feature	R210	R210 II	R310
Optional Storage Controller	Non-RAID: SAS 5/E LSI 2032 (for tape backup unit only) RAID: SAS 6/iR PERC 6/E PERC S100 (software RAID) PERC S300 (software RAID) PERC H200 PERC H800	Non-RAID: 6Gb/s SAS HBA RAID: PERC S100 (software RAID) PERC S300 (software RAID) PERC H200 PERC H800 (available Q4 2011)	Non-RAID: SAS 5/E LSI 2032 (for tape backup unit only) 6Gb/s SAS HBA RAID: SAS 6/iR PERC 6/E SAS 5/E PERC S300 (software RAID) PERC H200 PERC H700 PERC H800
Availability	ECC memory, quad-pack LED diagnostic, add-in RAID, TPM/CTPM	ECC memory, quad-pack LED diagnostic, add-in RAID, TPM/CTPM (available Q3 2011)	ECC memory, hot-plug hard drives, redundant power supplies, quad-pack LED diagnostic or LCD (with hot-plug hard drive chassis), TPM
Server Mgt.	BMC, IPMI 2.0 compliant, full Dell OpenManage™ suite Optional: iDRAC6 Express, iDRAC6 Enterprise, vFlash media	BMC, IPMI 2.0 compliant, full Dell OpenManage suite Optional: iDRAC6 Express, iDRAC6 Enterprise, vFlash media	BMC, IPMI 2.0 compliant, full Dell OpenManage suite Optional: iDRAC6 Express, iDRAC6 Enterprise, vFlash media
I/O Slots	1 x PCIe x16	1 x PCIe x16	1 x PCIe x16 (x8 routing) 1 x PCIe x8 (x8 routing) 1 x PCIe x8 (x4 routing)
RAID	See RAID options in chapter 12	See RAID options in chapter 12	See RAID options in chapter 12
NIC/LOM	2 x GbE LOM	2 x GbE LOM	2 x GbE LOM
USB	2 front, 2 back, 2 internal	2 front, 2 back, 2 internal	2 front, 2 back, 2 internal
Power Supplies	Non-redundant, 250W (80+ Bronze) auto-ranging (100V-240V)	Non-redundant, 250W (80+ Bronze) auto-ranging (100V-240V)	Non-redundant, 350W (80+ Bronze) Optional redundant, 400W (80+ Silver) auto-ranging (100V-240V)
Fans	Non-redundant, non-hot-pluggable	Non-redundant, non-hot-pluggable	Non-redundant, non-hot-pluggable
Form Factor	1U Rack	1U Rack	1U Rack

2 New Technologies

New technologies on the Dell PowerEdge™ R210 II include the following:

- New processors, including the Intel® Xeon® processor E3-1200 product family and the Intel Core™ processor i3-2100 product family
- Improved acoustics in small offices or branch offices over the predecessor system (PowerEdge R210)
- Shorter rack rail kits
- Front ear rack mounting option
- 1333 MHz 2 Gb-based memory
- 8 GB UDIMMs
- SAS 6 Gbps HBA external controller
- More efficient power supply (89%) (available Q3 2011)
- 2 Gb and 4 Gb memory DRAM technology
- Support for 3.5" 3 TB nearline SAS 7.2K rpm hard drives (available Q2 2011)
- Support for up to four 2.5" SSD or SAS hard drives (available Q2 2011)

3 System Overview

Table 2. Product Feature Summary

Feature	Technical Specification
Form Factor	1U rack
Processors	Quad-core Intel® Xeon® processor E3-1200 product family Dual-core Intel Core™ processor i3-2100 product family
Processor Sockets	1
Front Side Bus or HyperTransport	DMI II (Direct Media Interface)
Cache	8MB
Chipset	Intel C202
Memory ¹	Up to 32GB (4 DIMMs): 1GB/2GB/4GB/8GB DDR3 up to 1333MHz
I/O Slots	1 PCIe x16 G2 slot
RAID Controller	Internal Controllers: PERC H200 (6Gb/s) PERC S100 (software based) PERC S300 (software based) External Controllers: PERC H800 (6Gb/s) (available Q4 2011) External HBAs (non-RAID): 6GB/s SAS HBA
Drive Bays	Cabled options available: Up to two 3.5" SAS or SATA Up to four 2.5" SSD or SAS ²
Maximum Internal Storage	Up to 4TB
Hard Drives ¹	Cabled hard drive options: 3.5" SAS (15K, 10K), nearline SAS (7.2K), SATA (7.2K, 5.4K) 2.5" SSD or SAS (10K) ²
Communications	Broadcom® NetXtreme® 5709 Dual Port Gigabit Ethernet NIC, Copper, w/TOE PCIe x4 Broadcom NetXtreme 5709 Dual Port Gigabit Ethernet NIC, Copper, TOE/iSCSI PCIe x4 Broadcom NetXtreme II 5709 Quad Port Gigabit Ethernet NIC, Copper, w/TOE/iSCSI PCIe x4 Intel Gigabit ET Dual Port Adapter, Gigabit Ethernet NIC, PCIe x4 Intel Gigabit ET Quad Port Adapter, Gigabit Ethernet NIC, PCIe x4

Dell

Power Supply	Single cabled power supply (250W)
Availability	Quad-pack LED diagnostics, ECC memory, add-in RAID, TPM/TCM
Video	Matrox® G200eW with 8MB memory
Remote Management	iDRAC6 optional
Systems Management	Dell OpenManage™ BMC IPMI 2.0 compliant Unified Server Configurator Lifecycle Controller enabled through optional iDRAC6 Express, iDRAC6 Enterprise, and vFlash
Rack Support	ReadyRails™ static rails for toolless mounting in 4-post racks with square or unthreaded round holes or tooled mounting in 4-post threaded and 2-post (Telco) racks
Operating Systems	Microsoft® Windows® Small Business Server 2011 Microsoft Windows Server® 2008 R2 Foundation ³ SP1 (includes Hyper-V™ v2) Microsoft Windows Server 2008 SP2, x86/x64 (x64 includes Hyper-V™) Microsoft Windows Server 2008 R2 SP1, x64 (includes Hyper-V™ v2) Novell® SUSE® Linux® Enterprise Server Red Hat® Enterprise Linux For more information on the specific versions and additions, visit www.dell.com/OSsupport .
Featured Database Application	Microsoft SQL Server® solutions (see Dell.com/SQL)

¹GB means 1 billion bytes and TB equals 1 trillion bytes; actual capacity varies with preloaded material and operating environment and will be less.

²Maximum of four hard drives available Q2 2011.

³Windows Server 2008 R2 Foundation allows only 15 user accounts and requires certain Active Directory (AD) configurations. If not configured according to the product documentation, the software will generate warnings to correct the configuration. After a certain amount of time, the software will only run for one hour at a time until the configuration is corrected. For more information about these features review the product documentation located at <http://go.microsoft.com/fwlink/?LinkId=143551>

4 Mechanical

4.1 Chassis Description

The PowerEdge R210 II is a 1U rack-mount design that supports the following features:

- Two cabled 3.5” drive bays for SATA or SAS hard drives or four 2.5” drive bays for SAS or SSD drives (available Q2 2011)
- Dual Gigabit LAN on motherboard (LOM)
- Four DIMM slots
- TPM security feature
- One riser card for optional PCIe expansion card
- Optional iDRAC6 Enterprise and iDRAC6 Express card mounted on planar (without PCI slot occupied)
- Support for 11G slim static and slim sliding rails.
- Single non-redundant power supply
- Diagnostic LED panel

4.2 Dimensions and Weight

Figure 1 details the dimensions and weight for the PowerEdge R210 II.

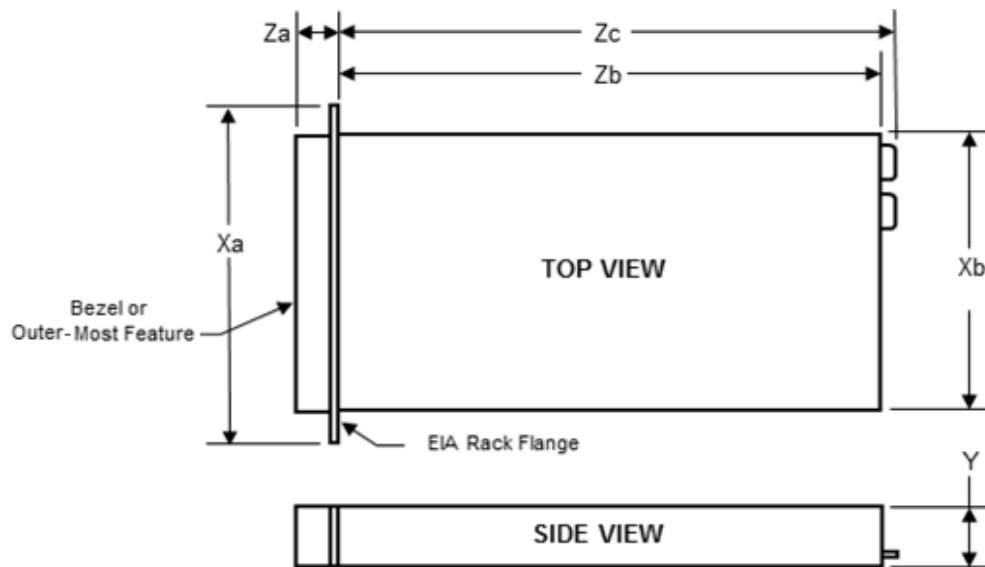

Xa	Xb	Y	Za (With Bezel)	Zb*	Zc	Max Weight
482.6mm	434mm	42.4mm	35mm	390.7mm	394.3mm	8.05 kg (17.76 lbs)

*Zb measures to the nominal rear wall external surface where the motherboard I/O connectors reside.

Figure 1. Chassis Dimensions

4.3 Front Panel View and Features

Figure 2 and Figure 3 show the front views of the PowerEdge R210 II.



Figure 2. Front View (With Bezel)



Figure 3. Front View (Without Bezel)

See the Front-Panel Features and Indicators section in the About Your System chapter of the *PowerEdge R210 II Owner's Manual* on Support.Dell.com for more information.

4.4 Back Panel View and Features

Figure 4 shows the back view of the PowerEdge R210 II.



Figure 4. Back View

See the Back-Panel Features and Indicators section in the About Your System chapter of the *PowerEdge R210 II Owner's Manual* on Support.Dell.com for more information.

4.5 Power Button LED

All Dell PowerEdge servers have a green LED integrated in the power button which indicates the system's power state.



Figure 5. Power Button

See the About Your System chapter of the *PowerEdge R210 II Owner's Manual* on Support.Dell.com for more information.

4.6 System Status ID

The System Status ID indicators are two LEDs—one on the front panel of the system and one on the back panel. These LEDs indicates the system state.

See the About Your System chapter of the *PowerEdge R210 II Owner's Manual* on Support.Dell.com for more information.

4.7 NIC Indicators

See the NIC Indicator Codes section in the About Your System chapter of the *PowerEdge R210 II Owner's Manual* on Support.Dell.com for more information.

4.8 Internal Chassis Views

Figure 6 shows the internal view of the PowerEdge R210 II server.

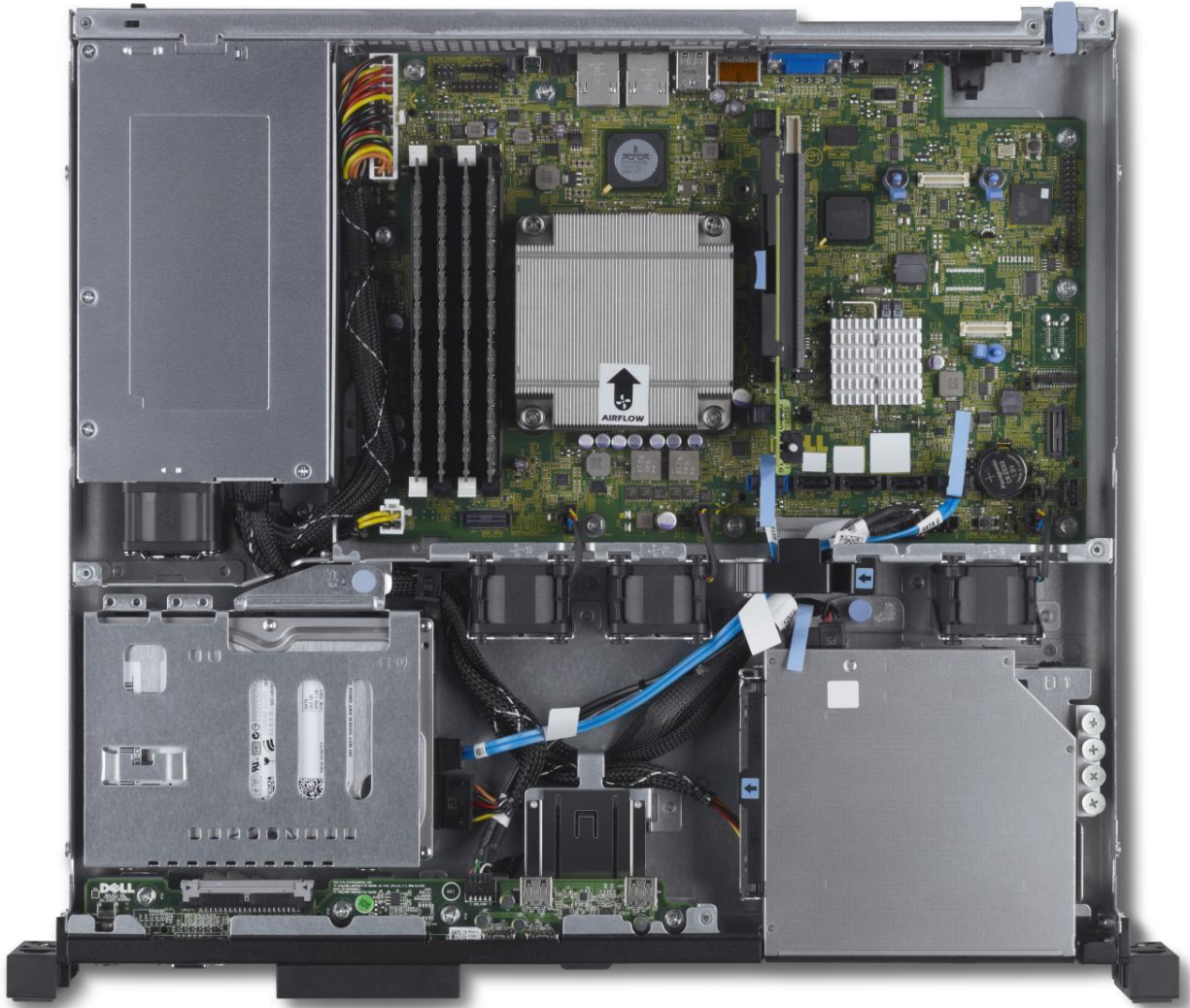

Figure 6. Internal Chassis View

4.9 Rails

4.9.1 ReadyRails Static Rails

ReadyRails™ Static Rails for 4-post and 2-post racks support the following:

- Toolless installation in 19" EIA-310-E compliant square or unthreaded round hole 4-post racks including all generations of Dell racks
- Toolled installation in 19" EIA-310-E compliant threaded hole 4-post and 2-post racks

See section 14 for more details.

4.10 Fans

There are three system fans located in the R210 II system.

Dell

For information on removing and installing the system fans, see the *Installing System Components* chapter of the *PowerEdge R210 II Owner's Manual* on Support.Dell.com for more information.

4.11 LED Control Panel

Figure 7 and Figure 8 show the LED control panel.



Figure 7. Front Panel View with LED Control Panel



Figure 8. LED Control Panel (Detailed View)

For a complete description of LED indicators, their causes, and possible courses of action to take to resolve an error, see the *Diagnostic Lights (Optional)* section in the *About Your System* chapter in the *PowerEdge R210 II Owner's Manual* on Support.Dell.com.

4.12 Security

4.12.1 Cover Latch

The PowerEdge R210 II comes with a coin-lock entry latch on the top cover of the unit and provides security for the entire system. The lock provides for toolless access to the chassis.

4.12.2 Bezel

A metal bezel is an available option and is mounted to the front of the chassis. A lock on the bezel is used to protect un-authorized access to system peripherals and the power button. System status on the LED control panel is viewable even when the bezel is installed.

4.12.3 Hard Drive

Cabled hard drives are only accessible by opening the top cover, thus locking the top cover secures the hard drives.

For information about installing or removing the hard drives, see the *Hard Drives* section in the *Installing System Components* chapter in the *PowerEdge R210 II Owner's Manual* on Support.Dell.com.

4.12.4 Trusted Platform Module (TPM)

The PowerEdge R210 II uses a TPM encryption chip solution on the system board with BIOS support worldwide, except for China where Trusted Computing Module (TCM) is the standard. TPM is disabled by default.

Dell

The TPM is used to generate and store keys, protect and authenticate passwords, and create and store digital certificates. The TPM can also be used to store Microsoft® BitLocker™ keys for hard drive encryption features in Microsoft® Windows Server® 2008. TPM is enabled through a BIOS option and uses HMAC-SHA1-160 for binding.

4.12.5 Power Switch Security

The control panel is designed so the power switch cannot be accidentally activated. The lock on the bezel secures the switch behind the bezel. In addition, there is a setting in the CMOS setup that disables the power button function.

4.12.6 Intrusion Alert

A chassis intrusion switch mounted inside the system chassis on the front panel board, and is used to detect chassis intrusion. When the cover is opened, the switch circuit closes and indicates intrusion.

4.12.7 Secure Mode

BIOS has the ability to enter a secure boot mode through setup. This mode includes the option to lock out the power and NMI switches on the control panel or set up a system password.

For more information, see the Using the System Setup Program and Boot Manager chapter in the *PowerEdge R210 II Owner's Manual* on Support.Dell.com.

4.13 USB Key

The PowerEdge R210 II supports two internal USB connectors which can be used for USB keys.

4.14 Battery

A replaceable coin cell CR2032 3V battery is mounted on the planar to provide backup power for the Real-Time Clock and CMOS RAM on the Intel® SP5100 chip.

4.14.1 Field Replaceable Units (FRU)

The planar contains a serial EEPROM to store Field Replaceable Unit (FRU) information including Dell part numbers, part revision levels, and serial numbers. This information is used by the SEL (system event log) and the BMC (baseboard management controller).

4.15 User Accessible Jumpers, Sockets, and Connectors

See the Jumpers and Connectors chapter in the *PowerEdge R210 II Owner's Manual* on Support.Dell.com.

5 Power, Thermal, Acoustic

5.1 Power Supplies

The base system includes a single 250W power supply. This unit provides power to the planar, the internal hard drive bays, and one slim optical disk drive bay. Power is soft-switched, allowing power cycling using a switch on the front of the system enclosure or through software control (server management functions). The power system is compatible with industry standards, such as ACPI and Server 2000. The power supply is equipped with automatic input voltage detection.

5.2 Power Supply Specifications

Table 3. Power Supply Specifications

Feature	Non-redundant Power Supply
Dimensions	L-210 mm x W-106 mm x H-40 mm
Status Indicators	None
Integrated Fans	One
AC Cord Rating	15 Amps @ 120 VAC, 10 Amps @ 240 VAC
Input Voltage	90 - 264 VAC
Auto-ranging	Yes
Line Frequency	47-63 Hertz
Maximum Inrush Current	Under typical line conditions and over the entire system ambient operating range, the inrush current may reach 55 Amps for 10 ms or less.
Hot-plug Capability	No
Output Power	250W
Maximum Heat Dissipation	1039 BTU per hour maximum
Efficiency 20% to 100% Load	82% to 85% @ 115 VAC 82% to 85% @ 230 VAC

5.3 Heat Dissipation

The heat dissipation for the R210 II power supply is measured at 1040 BTU/hr (maximum).

5.4 Environmental Specifications

The airborne contaminant level is class G2 or lower as defined by ISA-S71.04-1985.

Table 4 lists the environmental specifications for the R210 II.

Table 4. Environmental Specifications

Specification		Operating Requirements	Non-Operating Requirements
Temperature Ranges (for altitude ≤ 900m or 2952.75ft)		10° C to 35° C (50° F to 95° F)	-40° C to 65° C (-40° F to 149° F)
Temperature Ranges (for altitude > 900m or 2952.75ft)		10° C to T ¹ ° C (50° F to T ² ° F)	
Temperature Gradient (maximum per 60 minutes)		10° C	20° C
Humidity Percent Ranges (noncondensing)		20% to 80% (maximum wet bulb temperature = 29° C)	5% to 95% (maximum wet bulb temperature = 38° C)
Humidity Gradient (maximum per 60 minutes)		10%	10%
Altitude Ranges	Low Limits	-50ft (-15.2m)	-50ft (-15.2m)
	High Limits	10,000ft (3048m)	35,000ft (10,668m)

¹Use the formulas in Figure 9 to calculate the maximum operating temperature (in °C) for a given altitude. Use the first formula if the altitude is stated in meters; use the second formula if the altitude is stated in feet.

²Use the formulas in Figure 10 to calculate the maximum operating temperature (in °F) for a given altitude. Use the first formula if the altitude is stated in meters; use the second formula if the altitude is stated in feet.

$$35 - \frac{\text{Maximum Altitude(in meters)} - 900}{300} \text{ } ^\circ\text{C or } 35 - \frac{\text{Maximum Altitude(in ft)} - 2952.75}{984.25} \text{ } ^\circ\text{C}$$

Figure 9. Formulas for Maximum Operating Temperature for Given Altitude (°C)

$$95 - \left(\frac{(\text{Maximum Altitude(in meters)} - 900) \times 1.8}{300} \right) \text{ } ^\circ\text{F or } 95 - \left(\frac{(\text{Maximum Altitude(in ft)} - 2952.75) \times 1.8}{984.25} \right) \text{ } ^\circ\text{F}$$

Figure 10. Formulas for Maximum Operating Temperature for Given Altitude (°F)

Table 5 shows the shock and vibration specifications for the R210 II.

Table 5. Shock and Vibration Specifications

Maximum Vibration	
Operating	0.26Grms at 5-350Hz for 15 minutes
Storage	1.88Grms at 10-500Hz for 15 minutes
Maximum Shock	
Operating	One shock pulse in the positive z axis (one pulse on each side of the system) of 31G for 2.6ms in the operational orientation
Storage	<p>Six consecutively executed shock pulses in the positive and negative x, y, and z axes (one pulse on each side of the system) of 71G for up to 2ms.</p> <p>Six consecutively executed shock pulses in the positive and negative x, y, and z axes (one pulse on each side of the system) of Half-sine shock 71G for up to 2ms and square-wave shock 32G, 270 in/sec.</p>

5.5 ENERGY STAR Compliance

ENERGY STAR® qualified configurations can be accessed from the [ENERGY STAR Compliance results](#) landing page on Dell.com.

5.6 Thermal

The thermal design of the PowerEdge R210 II reflects the following:

- **Closed-loop thermal control algorithm:** A closed-loop thermal control method uses feedback temperatures to dynamically determine proper fan speeds.
- **Comprehensive thermal management:** The PowerEdge R210 II controls system cooling fan speed based on several different responses from critical component sensors, such as processor temperature, DIMM temperature, inlet ambient temperature, and system configurations. The thermal management adjusts proper cooling ability for the system according to what the system really needs.
- **Optimized Ventilation:** The R210 II chassis has a custom ventilation design for optimized air flow path. Each component and peripheral is ensured sufficient air for cooling.

5.7 Acoustics

The acoustical design of the PowerEdge R210 II reflects the following:

- **Adherence to Dell's high sound quality standards:** Sound quality is different from sound power level and sound pressure level in that it describes how humans respond to annoyances in sound, like whistles and hums. One of the sound quality metrics in the Dell specification is the prominence ratio of a tone, which is listed in Table 6.
- **Office environment acoustics:** Compare the values for LpA in Table 6 and note that they are lower than ambient measurements of typical office environments.

Dell

- **Hardware configurations affect system noise levels:** Dell’s thermal control provides for cooling flexible to varying hardware configurations. Acoustical performance associated with two common configurations is listed in Table 6.
- **Noise ramp and descent at boot:** Fan speeds (and corresponding noise levels) ramp up during the boot process to add a layer of protection for component cooling, in the event that the system does not boot properly.

The acoustical performance for minimum and typical configurations of the PowerEdge R210 II are shown in Table 6.

Table 6. Acoustical Specifications

Minimum Configuration @ 23 °C Ambient				Operating Mode	LwA-UL (bels)	LpA (dBA)	Prominent Tones
Processor	Hard Drives	Power Supply	RAID				
Intel® Core™ i3-2100 (65W)	1 x 3.5” SATA (7.2k) 250GB	1 x 250W	None	Standby	2.8	16	None
				Idle	5.0	38	None
				Active hard drives	5.1	38	None
				Stressed processor	5.0	38	None
Typical Configuration @ 23 °C Ambient				Operating Mode	LwA-UL (bels)	LpA (dBA)	Prominent Tones
Processor	Hard Drives	Power Supply	RAID				
Intel® Xeon® E3-1200 product family (80W)	2 x 3.5” SATA (7.2k) 500GB	1 x 250W	PERC H200	Standby	2.8	16	None
				Idle	5.2	40	None
				Active hard drives	5.2	41	None
				Stressed processor	5.2	41	None

Definitions

Standby: AC Power is connected to power supplies but the system is not turned on.

Idle: Reference ISO7779 (1999) definition 3.1.7; system is running in its OS but no other specific activity.

Active Hard Drives: An operating mode per ISO7779 (1999) definition 3.1.6; Section C.9 of ECMA-74 9th ed. (2005) is followed in exercising the hard disk drives.

Stressed Processor: An operating mode per ISO7779 (1999) definition 3.1.6; SPECPower set to 50% loading is used.

LwA-UL: The upper limit sound power level (LwA) calculated per section 4.4.2 of ISO 9296 (1988) and measured in accordance to ISO 7779 (1999).

Dell

LpA-Op: A-Weighted sound pressure level. The system is placed in center of ISO7779 table, while the acoustic transducer is located 150 cm above the floor and 50 cm in front of the equipment.

Prominent tones: Criteria of D.6 and D.11 of ECMA-74 11th ed. (2010) are followed to determine if discrete tones are prominent. The system is placed in a rack with its bottom at 75-cm from the floor. The acoustic transducer is at front bystander position, ref ISO7779 3rd (2010), Section 8.6.2.

6 Processors

6.1 Overview

The processors for the R210 II are based on the latest two- and four-core offerings from the Intel® Xeon® processor E3-1200 product family or the Intel® Core™ processor i3-2100 product family series.

6.2 Features

Key features of the Intel® Xeon® processor E3-1200 product family or the Intel® Core™ processor i3-2100 product family include:

- New microarchitecture on 32nm process delivers higher performance and lower power.
- Intel® Advanced Vector Extensions (AVX) allows for better acceleration of floating point intensive applications.
- Next generation Intel Turbo Boost Technology maximizes processor performance during workload spikes by allowing the processor to briefly operate above TDP.
- New Advanced Encryption Standard (AES) provides improved encryption and decryption performance.
- Increased processor performance of up to 25% over previous generation.
- Memory and I/O: 2x memory footprint at 32GB; 4 additional PCIe lanes (20).
- Storage: 6 SATA 3Gb/s ports.
- Efficiency: Low power Intel Xeon® processor options.
- Reliability: Error Correcting Code (ECC) memory to improve data integrity.
- Server validation: With server operating systems, server class peripherals and adapters to ensure compatibility.
- Storage: RAID support for Linux operating systems.

6.3 Supported Processors

Processors supported on the R210 II are listed in Table 7 and Table 8. For the most up-to-date listings, see Dell.com.

Table 7. Supported Intel Xeon Processors

Model	Speed (GHz)	Power (Watts)	Cores	L3 Cache (MB)	Threads	Turbo	Memory (MHz)	Process
E3-1280	3.50	95	4	8	8	Yes	1333	32nm
E3-1270	3.40	80	4	8	8	Yes	1333	32nm
E3-1240	3.30	80	4	8	8	Yes	1333	32nm
E3-1230	3.20	80	4	8	8	Yes	1333	32nm
E3-1220	3.10	80	4	8	4	Yes	1333	32nm
E3-1260L	2.40	45	4	8	8	Yes	1333	32nm
E3-1220L	2.20	20	2	3	4	Yes	1333	32nm

Table 8. Supported Intel Desktop Processors

Model	Speed (GHz)	Power (Watts)	Cores	L2/L3 Cache (MB)	Threads	Turbo	Memory (MHz)	Process
Intel Core™ i3-2100	3.10	65	2	3	4	No	1333	32nm
Intel Pentium® G850	2.90	65	2	3	2	No	1333	32nm
Intel Pentium G620	2.60	65	2	3	2	No	1333	32nm

6.4 Processor Configurations

The R210 II is a single socket server and the memory controller embedded in the processor supports 4 DIMMs. Memory configuration with one processor includes a 1 GB minimum and a 32 GB maximum.

6.5 Processor Installation

Refer to the Processors section in the Installing System Components chapter of the *Dell PowerEdge R210 II Systems Owner's Manual* on Support.dell.com for processor installation and removal instructions.

7 Memory

7.1 Overview

The R210 II supports DDR3 memory, providing a high performance, high speed memory interface capable of low latency response and high throughput. For the Intel processor-based R210 II, up to 4 total DIMMs are supported. Additional specifics regarding memory include:

- 2 Gb DRAM technology
 - 2 channels per processor
 - Unbuffered (UDIMM) ECC DDR3 DIMMs
 - DDR3 speeds of 1066/1333 (UDIMM only)
- Single- and dual-rank UDIMMs (all channels in a system run at the fastest common frequency)
- Support for up to 32 GB UDIMM memory (4 x 8 GB UDIMMs)
- Single DIMM configuration only with DIMM in socket A1
- No support for quad-rank DIMMs
- No RDIMM support
- Low-voltage (LV) DIMM supported @ 3.5V only
- Non-ECC DIMMs not supported

7.2 DIMMs Supported

The R210 II supports a minimum of 1 GB upgradeable to 32 GB of RAM using the following DIMM sizes:

Table 9. DIMMs Supported

Unbuffered	DRAM Technology
DDR3 1333 1GB DIMM, Single Rank	2Gb
DDR3 1333 2GB DIMM, Single Rank	2Gb
DDR3 1333 4GB DIMM, Dual Rank	2Gb
DDR3 1333 8GB DIMM, Dual Rank	4Gb

7.3 DIMM Slots

The PowerEdge R210 II has 4 DIMM slots for memory, supporting up to 2 DIMMs per channel.

7.4 Speed

The memory frequency is determined by a variety of inputs:

- Speed of the DIMMs
- Speed supported by the processor
- Configuration of the DIMMs

The memory speed of each channel depends on the memory configuration:

- For single-rank memory modules
 - One memory module per channel supports up to 1333 MHz
 - Two memory modules per channel supports up to 1333 MHz

Dell

- For dual-rank memory modules
 - One memory module per channel supports up to 1333 MHz
 - Two memory modules per channel supports up to 1066 MHz

If memory modules with different speeds are installed, they will operate at the speed of the slowest installed memory module(s).

7.5 Sparing

Memory sparing is not supported.

7.6 Mirroring

Memory mirroring is not supported.

7.7 RAID

Memory RAID is not supported.

7.8 Supported Configurations

Supported memory configurations for the R210 II are listed in Table 10. For the latest information on memory options, visit Dell.com.

Table 10. Supported Configurations

System Capacity (GB)	DIMM Quantity	DIMM Type	DIMM Speed (MHz)	System Speed (MHz)	Memory Channel	Number of Ranks	Memory Data Width
1	1	UDIMM	1333	1333	1	1	x8
2	1	UDIMM	1333	1333	1	1	x8
2	2	UDIMM	1333	1333	2	1	x8
4	2	UDIMM	1333	1333	2	1	x8
4	4	UDIMM	1333	1333	2	1	x8
4	1	UDIMM	1333	1333	1	2	X8
8	4	UDIMM	1333	1333	2	1	x8
8	2	UDIMM	1333	1333	2	2	x8
16	4	UDIMM	1333	1333	2	2	x8
16	2	UDIMM	1333	1333	2	2	X8
32	4	UDIMM	1333	1333	2	2	X8

8 Chipset

8.1 Overview

The PowerEdge R210 II planar incorporates the Intel C200 Series PCH chipset. The features listed below are part of the chipset.

8.2 Direct Media Interface

Direct Media Interface (DMI) is the chip-to-chip connection between the processor and C200 series chipset. This high-speed interface integrates advanced priority-based servicing allowing for concurrent traffic and true isochronous transfer capabilities. Base functionality is completely software-transparent, permitting current and legacy software to operate normally.

8.3 PCI Express Interface

The C200 series provides up to 8 PCI Express root ports. Each root port supports 5GT/s bandwidth. PCI Express Root Ports 1-4 can be statically configured as four x1 ports or ganged together to form one x4 port. Ports 5 and 6 can only be used as two x1 ports.

8.4 SATA Interface

The chipset has two integrated SATA host controllers that support independent DMA operation on up to six port: 6 x 3Gb/s SATA. The SATA controller contains two modes of operation, a legacy mode using I/O space and an AHCI mode using memory space. Software that uses legacy mode will not have AHCI capabilities.

8.5 AHCI

The chipset provides hardware support for Advanced Host Controller Interface (AHCI), a new programming interface for SATA host controllers. Platforms supporting AHCI may take advantage of performance features such as no master/slave designation for SATA devices—each device is treated as a master—and hardware-assisted native command queuing. AHCI also provides usability enhancements such as Hot-Plug. AHCI requires appropriate software support (for example, an AHCI driver) and for some features, hardware support in the SATA device or additional platform hardware.

8.6 PCI Interface

The C200 Series chipset PCI interface provides a 33 MHz, Revision 2.3 implementation. The chipset integrates a PCI arbiter that supports up to four external PCI bus masters in addition to the internal requests. This allows for combinations of up to 8 PCI down devices and PCI slots.

8.7 Low Pin Count (LPC) Interface

The LPC bridge function of the PCH resides in PCI Device 31: Function 0. In addition to the LPC bridge function, D31:F0 contains other functional units including DMA, Interrupt controllers, Timers, Power Management, System Management, GPIO, and RTC.

8.8 Serial Peripheral Interface (SPI)

The chipset implements an SPI Interface as an alternative interface for the BIOS flash device. An SPI flash device can be used as a replacement for the FWH, and is required to support Gigabit Ethernet,

Dell

Intel® Active Management Technology, and integrated Intel Quiet System Technology. The chipset supports up to two SPI flash devices with speed up to 20 MHz, 33 MHz utilizing two chip select pins.

8.9 Compatibility Module

The DMA controller incorporates the logic of two 82C37 DMA controllers, with seven independently programmable channels. Channels 0-3 are hardwired to 8-bit, count-by-byte transfers, and channels 5-7 are hardwired to 16-bit, count-by-word transfers. Any two of the seven DMA channels can be programmed to support fast Type-F transfers. Channel 4 is reserved as a generic bus master request.

The chipset supports LPC DMA, which is similar to ISA DMA, through the DMA controller. LPC DMA is handled through the use of the LDRQ# lines from peripherals and special encoding on LAD[3:0] from the host. Single, Demand, Verify, and Increment modes are supported on the LPC interface.

The timer/counter block contains three counters that are equivalent in function to those found in one 82C54 programmable interval timer. These three counters are combined to provide the system timer function, and speaker tone. The 14.31818 MHz oscillator input provides the clock source for these three counters.

The chipset provides an ISA-Compatible Programmable Interrupt Controller (PIC) that incorporates the functionality of two, 82C59 interrupt controllers. The two interrupt controllers are cascaded so that 14 external and two internal interrupts are possible. In addition, the chipset supports a serial interrupt scheme.

All of the registers in these modules can be read and restored. This is required to save and restore system state after power has been removed and restored to the platform.

8.10 Advanced Programmable Interrupt Controller (APIC)

In addition to the standard ISA compatible Programmable Interrupt Controller (PIC) described in the previous section, the Ibex Peak incorporates the Advanced Programmable Interrupt Controller (APIC).

8.11 USB Interface

The C200 Series chipset contains up to two Enhanced Host Controller Interface (EHCI) host controllers that support USB high-speed signaling. High-speed USB 2.0 allows data transfers up to 480 Mb/s which is 40 times faster than full-speed USB. The chipset also contains up to seven Universal Host Controller Interface (UHCI) controllers that support USB full-speed and low-speed signaling.

The chipset supports up to fourteen USB 2.0 ports. All fourteen ports are high-speed, full-speed, and low-speed capable. The port-routing logic determines whether a USB port is controlled by one of the UHCI or EHCI controllers.

8.12 Real-Time Clock (RTC)

The Real Time Clock (RTC) module provides a battery backed-up date and time keeping device with two banks of static RAM with 128 bytes each, although the first bank has 114 bytes for general purpose usage. Three interrupt features are available: time of day alarm with once a second to once a month range, periodic rates of 122 μ s to 500 ms, and end of update cycle notification. Seconds, minutes, hours, days, day of week, month, and year are counted. Daylight savings compensation is no longer supported. The hour is represented in twelve or twenty-four hour format, and data can be represented in BCD or binary format. The design is functionally compatible with the Motorola MS146818B. The time keeping comes from a 32.768 kHz oscillating source, which is divided to achieve an update every second. The lower 14 bytes on the lower RAM block has very specific

Dell

functions. The first ten are for time and date information. The next four (0Ah to 0Dh) are registers, which configure and report RTC functions.

8.13 GPIO

Various general purpose inputs and outputs are provided for custom system design. The number of inputs and outputs varies depending on C200 series configuration.

8.14 Enhanced Power Management

The C200 series power management functions include enhanced clock control and various low-power (suspend) states (for example, Suspend-to-RAM and Suspend-to-Disk). A hardware-based thermal management circuit permits software-independent entrance to low-power states. The chipset contains full support for the Advanced Configuration and Power Interface (ACPI) Specification, Revision 3.0a.

8.15 System Management Features

In addition to Intel AMT, the C200 series chipset integrates several functions designed to manage the system and lower the total cost of ownership (TCO) of the system. These system management functions are designed to report errors, diagnose the system, and recover from system lockups without the aid of an external microcontroller.

8.15.1 TCO Timer

The chipset's integrated programmable TCO timer is used to detect system locks. The first expiration of the timer generates an SMI# that the system can use to recover from a software lock. The second expiration of the timer causes a system reset to recover from a hardware lock.

8.15.2 Processor Present Indicator

The chipset looks for the processor to fetch the first instruction after reset. If the processor does not fetch the first instruction, the Ixex Peak will reboot the system.

8.15.3 Error Code Correction (ECC) Reporting

When detecting an ECC error, the host controller has the ability to send one of several messages to the chipset. The host controller can instruct the chipset to generate an SMI#, NMI, SERR#, or TCO interrupt.

8.15.4 Function Disable

The chipset provides the ability to disable the following integrated functions: LAN, USB, LPC, Intel HD Audio, SATA, PCI Express or SMBus. Once disabled, these functions no longer decode I/O, memory, or PCI configuration space. Also, no interrupts or power management events are generated from the disabled functions.

8.15.5 Intruder Detect

The chipset provides an input signal (INTRUDER#) that can be attached to a switch that is activated when the system case is opened. The chipset can be programmed to generate an SMI# or TCO interrupt due to an active INTRUDER# signal.

8.16 System Management Bus (SMBus 2.0)

The chipset contains an SMBus Host interface that allows the processor to communicate with SMBus slaves. This interface is compatible with most I2C devices. Special I2C commands are implemented.

The chipset's SMBus host controller provides a mechanism for the processor to initiate communications with SMBus peripherals (slaves). Also, the chipset supports slave functionality, including the Host Notify protocol. Hence, the host controller supports eight command protocols of the SMBus interface.

The chipset's SMBus also implements hardware-based Packet Error Checking for data robustness and the Address Resolution Protocol (ARP) to dynamically provide address to all SMBus devices.

8.17 Intel Virtualization Technology for Directed I/O

The chipset provides hardware support for implementation of Intel Virtualization Technology with Directed I/O (Intel VT-d). Intel VT-d Technology consists of technology components that support the virtualization of platforms based on Intel Architecture Processors. Intel VT-d Technology enables multiple operating systems and applications to run in independent partitions. A partition behaves like a virtual machine (VM) and provides isolation and protection across partitions. Each partition is allocated its own subset of host physical memory.

9 BIOS

9.1 Overview

The R210 II BIOS is based on the Insyde® BIOS core which supports the following features:

- Simultaneous Multi-Threading (SMT) support
- PCI 2.3 compliant
- Plug and Play 1.0a compliant
- MP (Multiprocessor) 1.4 compliant
- Ability to boot from hard drive, optical drive, iSCSI drive, USB key, and SD card
- ACPI 2.0 support (S0, OS-S4, S5 States)
- PXE and WOL support for on-board NICs
- SETUP access through <F2> key at end of POST
- USB 2.0 (USB boot code is 1.1 compliant)
- F1/F2 error logging in CMOS
- Virtual KVM, CD, and floppy support
- iDRAC supported
- Unified Server Configurator (UEFI 2.1) support
- Power management support including DBS, Power Inventory and multiple Power Profiles:
 - Maximum Performance
 - OS Control (DBS)
 - Custom
- SMBIOS 2.5
- PCI-to-PCI bridge 1.0 compliant
- Dell Server Assistant 7.0 support
- System Service support
- Onboard PCI video BIOS support
- SATA-enabled for CD-ROM and hard drives
- PCI FW 3.0 compliant
- Selectable Boot support
- El Torito CD-ROM Boot 1.0
- Remote BIOS Update support
- Remote Configuration Interface (RCI) support
- Console redirection through COM1
- PXE support based on Preboot Execution Environment Specification v2.1
- 2-byte ID support
- ePPID support in flash
- Memory remapping support
- DDR3 UDIMM memory support
- UEFI shell Support
- AC recovery staggering Power-Up
- DIMM mismatch checking
- VT-d

The PowerEdge R210 II BIOS does not support the following:

- BIOS language localization
- BIOS recovery after bad flash
- RIB Support

9.2 Supported ACPI States

- ACPI compliance: S0, S4, S5 supported
- No S1, S2, S3 (STR) support
- S4 supported by OS only

Table 11. Supported ACPI States

Events (Wake Up)	S0 System ON	S1	S2/S3	S4 Hibernate (OS supported)	S5 Soft Off
Power Button	✓	–	–	✓	✓
RTC alarm	–	–	–	✓	–
WOL	–	–	–	✓	–
iDRAC	✓	–	–	✓	✓

9.2.1 Power Management Modes

The R210 II uses operating system-based power management.

9.2.1.1 Power Saving BIOS Setting (OS Control)

Intel processors support Demand Based Switching (DBS) which enables the processor to dynamically change its operating frequency in response to workload changes. The industry standard implementation of this power management feature is in the Operating System (OS). The OS monitors process and thread level utilization of the processor and uses processor controls to change the processor's operating frequency. For heavy workloads, the OS runs the processor at higher frequencies for additional performance. Lighter workloads do not need high performance, thus the OS runs the processor at lower frequencies.

9.2.1.2 Maximum Performance

The Maximum Performance Mode disables power management. In this mode, the processor frequency is statically set to the highest supported frequency.

The power management features are implemented through two categories: fixed or generic. Fixed features use bits defined in the ACPI specification for specific capabilities. The fixed feature bits give the OS complete control over the power management of a device since the location of the bits is given to the OS in the FACP table. Thus, a driver can directly access bits to control a device's power management. **Generic** features have defined enable and status bits, but the functionality is not fully visible to the OS. Dell provides ASL code to handle the details of generic features, allowing the OS to intelligently communicate with system-specific hardware.

Table 12 summarizes the power management features on this system:

Table 12. Power Management Features

Feature	Type	Enable/Status/ Ctrl bit location	Description
ACPI mode switch	Fixed	PCH	The OS uses the SCI_EN bit to switch from legacy mode to ACPI mode.
Sleep states	Fixed	PCH	Supported states: S0(Working), S4-OS ('Hibernation' in W2K), and S5 (Soft-off). S1 (also called 'standby' or 'suspend') and S3 are not supported.
Power Button	Fixed	PCH	In ACPI mode, OS has control of the power button. In non-ACPI mode, SMI handler owns power button events.
Real-Time Clock	Fixed	PCH	The OS is able to configure the system to wake on the RTC alarm.
Power Mgmt. Timer	Fixed	PCH	24-bit power management timer is used.
Power Mgmt. Event (PME)	Generic	PCH	Each host bus's PME# signal is routed to a separate general-purpose event pin in the chipset. When a device signals PME#, the system wakes (if necessary), the OS detects the event, and a Dell-defined ASL routine handles the event. Wake-on-LAN is one example of a PME.
USB wake	Generic	N/A	This feature is not supported on this system since the S1 state is not supported.
DBS	N/A	Processor MSRs	This feature does P state transition under Windows
C State Support	N/A	Processor and PCH registers	This feature allows multiple C state supports for Processor. This feature will work under Windows and ACPI OS that understand C states.
Power Profile support	N/A	Processor/IMC and PCH chipset registers	In addition to P,C and T states, BIOS will expose the Power Profiles to the OS. Each Power profile will have a specific settings and it will fine tune processor, MCH, IOH and South Bridge.

Table 13 shows the power profile options for the R210 II.

Table 13. Power Profiles

Maximum Performance	DBPM Disabled (BIOS sets P-State to max) Memory frequency = Maximum Performance Fan algorithm = Maximum Performance
OS Control	Enable OS DBPM Control (BIOS exposes all possible P states to OS) Memory frequency = Maximum Performance Fan algorithm = Minimum Power
Custom	CPU Power and Performance Management: Maximum Performance Minimum Power OS DBPM System DBPM Memory Power and Performance Management: Maximum Performance 1333Mhz 1067Mhz 800Mhz Minimum Power Fan Algorithm Maximum Performance Minimum Power

10 Embedded NICs/LAN on Motherboard (LOM)

10.1 Overview

The PowerEdge R210 II includes a Broadcom® 5716C chip embedded on the motherboard. The 5716 chip is connected to the IOH via a PCI Express x4 gen2 link. The 5716 chip provides two 1x Gigabit Ethernet ports with two RJ-45 connectors on the rear of the system. Other details include:

- The firmware for the LOM chip resides in a flash part
- The R210 II supports Wake-On-LAN (WOL) from either port

10.2 Features

The Broadcom® 5716C controller-based LOM supports multiple functions over a unified fabric to help manage Ethernet, iSCSI and remote management traffic on each port simultaneously. The LOM provides dual 10/100/1000 Gigabit Ethernet functions, an IEEE 802.3-compliant media access controller (MAC), and a UTP copper physical layer transceiver solution for high-performance network applications. The LOM also supports the following functions:

- Multiple speed support with dual 10/100/1000-Mbps Ethernet MACs, including half-duplex and full-duplex capability and a dual 10/100/1000 copper PHY
- PCIe compliance with an x4 PCI Express v2.0- and v1.1-compliant bus interface
- Diagnostics:
 - Link quality indicator LED
 - Link speed indicator LED
 - Broadcom remote cable management and diagnostics software (Broadcom Advanced Control Suite [BACS])
 - LOM continually monitors various channel conditions
- Power management options
- Teaming using Broadcom software:
 - Support for virtual LANs (VLANs):
 - Split your physical LAN into logical parts
 - Create logical segmentation of workgroups
 - Enforce security policies for each logical segment
 - Group multiple network adapters together into teams, providing network load balancing and fault tolerance functionality
- Support for Pre-boot Execution Environment (PXE), iSCSI boot, and Bootstrap Protocol (BootP)
- Support for Network Controller Sideband Interface (NC-SI)
- IPv4 and IPv6 checksum offload
- IPv4 and IPv6 large send offload
- Jumbo MTU
- LSO and jumbo frames
- WOL capabilities
- Virtualization functionality
- Use of multiple queues

11 PCI Slots

11.1 Overview

The PowerEdge R210 II planar provides one riser card which provides one x16 Gen2 PCI Express expansion slot:

- Slot supports full-height half-length cards connected to the IOH
- Support for 25W maximum power
- System does not support hot-plugging or hot-removal of PCIe cards

For more information on installing expansion cards and expansion-card priority, see the Expansion Cards and Expansion-Card Risers section in the Installing System Components chapter of the *Dell PowerEdge R210 II Owner's Manual* on Support.dell.com.

11.2 Quantities and Priorities

Refer to the Expansion Cards and Expansion-Card Risers section in the Installing System Components chapter of the *Dell PowerEdge R210 II Owner's Manual* on Support.dell.com.

11.3 PCI Card Dimensions

Refer to the Expansion Cards and Expansion-Card Risers section in the Installing System Components chapter of the *Dell PowerEdge R210 II Owner's Manual* on Support.dell.com.

12 Storage

12.1 Overview

The PowerEdge R210 II supports the following hard drive configurations:

- 2 x 3.5" cabled SATA drives using the motherboard SATA connector
- 2 x 3.5" cabled SAS, nearline SAS, or SATA drives using an add-on storage controller
- 4 x 2.5" SSD or SAS drives using an add-on storage controller (available Q2 2011)

The hard-drive configuration must be selected at point of purchase and is not an upgrade option.

12.2 Hard Drives

Table 14 lists the supported hard drives for the PowerEdge R210 II. For the latest information on supported hard drives, visit Dell.com.

Table 14. Supported Hard Drives

Form Factor	Capacity	Speed	Type
3.5"	250GB, 500GB, 1TB, 2TB	7.2K	SATA
3.5"	500GB, 1TB, 2TB	7.2K	NL SAS
3.5"	146GB, 300GB, 450GB, 600GB	15K	SAS
2.5" ¹	100GB, 200GB	N/A	SATA SSD
2.5"	146GB, 300GB, 600GB, 900GB	10K	SAS

¹2.5" drives available Q2 2011.

12.3 RAID Configurations

Table 15 details the factory RAID configurations for the PowerEdge R210 II.

Table 15. Factory RAID Configurations

Config Type	Configurations # Name		Description	Non-Mixed Drives, all SATA, all SSD, or all SAS	
				Min HDD	Max HDD
SATA—No RAID	1	MSTCBL	On-board SATA Controller	1	2
SATA RAID	2	MSTR0CBL	Embedded SATA SW RAID (PERC S100)—RAID 0	2	2
	3	MSTR1CBL	Embedded SATA SW RAID (PERC S100)—RAID 1	2	2
SAS/SATA RAID	4	ASSR0CBL	Add-in SAS/SATA RAID card, RAID 0 (PERC S300) with 2 hard drives	2	2

	5	ASSR0CBL	Add-in SAS/SATA RAID card, RAID 0 (PERC S300)	3	4
	6	ASSR1CBL	Add-in SAS/SATA RAID 1 (PERC S300)	2	2
	7	ASSR5CBL	Add-in SAS/SATA RAID card, RAID 5 (PERC S300)	3	4
	8	ASSR10CBL	Add-in SAS/SATA RAID card, RAID 10 (PERC S300)	4	4
	9	ASSCBL	Add-in SAS/SATA RAID card, No RAID (PERC H200)	1	4
	10	ASSR0CBL	Add-in SAS/SATA RAID card, RAID 0 (PERC H200)	2	4
	11	ASSR1CBL	Add-in SAS/SATA RAID card, RAID 1 (PERC H200)	2	2
SAS/SSD RAID	12	ASSR10CBL	Add-in SAS/SSD RAID card, RAID 10 (PERC H200)	4	4

Note: Configurations that require more than 3 hard drives will be available in Q2 2011.

Additional restrictions for RAID configurations are listed as follows:

- Hard drives must be all 3.5" or 2.5" (2.5" drives available Q2 2011)
- Must be all SAS or all SATA or all SSD
- No Mixed Hard drives allowed
- SSD support requires PERC H200
- PERC S300 does not support SSD

The PERC S300 does not support the following virtualization solutions:

- Microsoft® Hyper-V™ server 2008 x64 (download version)
- Microsoft Windows Server® 2008 x64 (Hyper-V™ role enabled)
- Microsoft Windows Server 2008 SP2 x64 (Hyper-V™ role enabled)
- Microsoft Windows Server 2008 R2 (Microsoft Windows® 7 includes SP2 bits) x64 (Hyper-V role enabled)

The PERC S300 does not support Linux® operating systems or VMware® virtualization software.

12.4 Optical Drives

The R210 II supports one SATA interface DVD-ROM or DVD+/-RW.

12.5 Tape Drives

External tape drives and tape libraries are supported. No internal tape drive support is available.

For more information on supported tape drives and tape libraries, see Dell.com/Storage.

13 Video

The PowerEdge R210 II includes a Matrox® G200eW with 8 MB memory integrated in Winbond® WPCM450 (BMC controller).

The resolutions supported are listed in Table 16.

Table 16. Graphics Video Modes

Resolution	Refresh Rate (Hz)	Color Depth (bit)
640 x 480	60, 72, 75, 85	8, 16, 32
800 x 600	60, 72, 75, 85	8, 16, 32
1024 x 768	60, 70, 75, 85	8, 16, 32
1280 x 1024	60, 75, 85	8, 16
1280 x 1024	60	32

14 Rack Information

14.1 Overview

The ReadyRails™ static rail systems for the R210 II provide toolless support for racks with square or unthreaded round mounting holes including all generations of Dell racks. The rail systems also offer tooled mounting support for 4-post threaded and 2-post (Telco) racks for added versatility. See Table 17 for the list of supported rails and racks.

14.2 Rails

Two different static rail systems are available for the R210 II: the A4 rail system and the A6 rail system. Both support toolless mounting in 19"-wide, EIA-310-E compliant square hole and unthreaded round hole racks using the ReadyRails™ mounting interface. Both also support a generic mounting interface for tooled mounting in threaded hole and 2-post (Telco) racks. Screws are not included in either kit because threaded racks are offered with a variety of thread designations.

Table 17. Supported Racks

Product	Rail ID	Mounting Interface	Rail Type	Rack Types Supported				
				4-Post			2-Post	
				Square	Round	Thread	Flush	Center
R210 II	A4	ReadyRails/Generic	Static	✓	✓	✓	✓	✓
	A6	ReadyRails/Generic	Static	✓	✓	✓	✓	✓

The A6 rail system also supports a cantilever (ear) mounting option, although it is not recommended since it does not support shipment of the server in the rack and allows the position of the server to exceed its designated U-space.

The key difference between the A4 and A6 rail systems is the overall length of the rail members. The A6 rail system, which is the default rail system being offered with the R210 II, is the shorter of the two and is well suited for mounting in 2-post racks or in 4-post racks with mounting flanges that are spaced in the 500-760 mm range. The A4 rail system is longer and can be used for mounting in 4-post racks with mounting flanges that are spaced in the 600-890 mm range. See Table 18 for specific adjustment range information on each rail system.

Table 18. Rail Adjustability Ranges and Depth

Product	Rail ID	Mounting Interface	Rail Type	Rail Adjustability Range (mm)						Rail Depth (mm)	
				Square		Round		Threaded		without CMA	with CMA
				Min	Max	Min	Max	Min	Max		
R210 II	A4	ReadyRails/Generic	Static	608	879	594	872	604	890	622	—
	A6	ReadyRails/Generic	Static	508 ¹	751	494 ¹	744	519 ¹	762	515 ¹ 376 ²	—

¹With middle brackets removed

²With rear brackets removed (applies to 2-post or cantilever mount only)

The min-max values listed in Table 18 represent the allowable distance between the front and rear mounting flanges in the rack. Rail depth represents the minimum depth of the rail as measured from the rack front mounting flanges when the rail rear bracket is positioned all the way forward.

14.3 Cable Management Arm (CMA)

The static rails for the R210 II support a wide variety of racks and mounting configurations but do not support the ability to extend the system out of the rack for service. Thus, they do not provide support for a cable management arm (CMA).

14.4 Rack View

The A4 and A6 rail systems are stab-in designs, meaning that the inner (chassis) rail members must first be attached to the sides of the system and then inserted into the outer (cabinet) members installed in the rack.



Figure 11. A4 Static Rail System

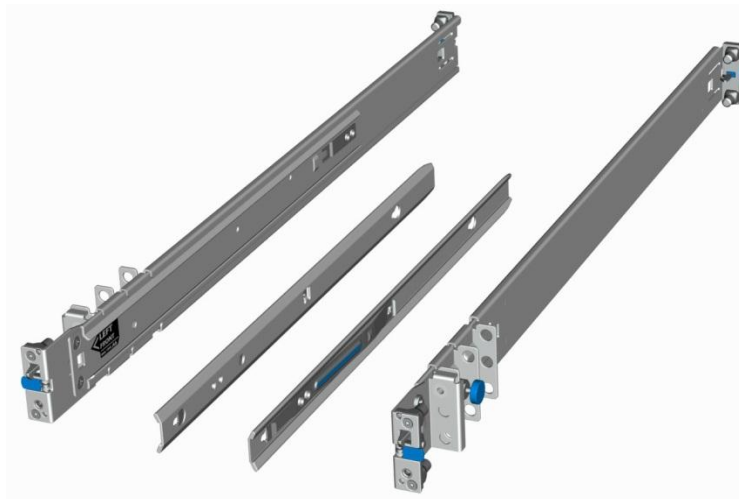

Figure 12. A6 Static Rail System

Figure 13 shows a view of the R210 II mounted in the A4 A6 rail systems in the 2-post *center-mount* configuration. The rear brackets on the A6 rail system can be removed and discarded, providing a much smaller mounting footprint than the A4 rail system.

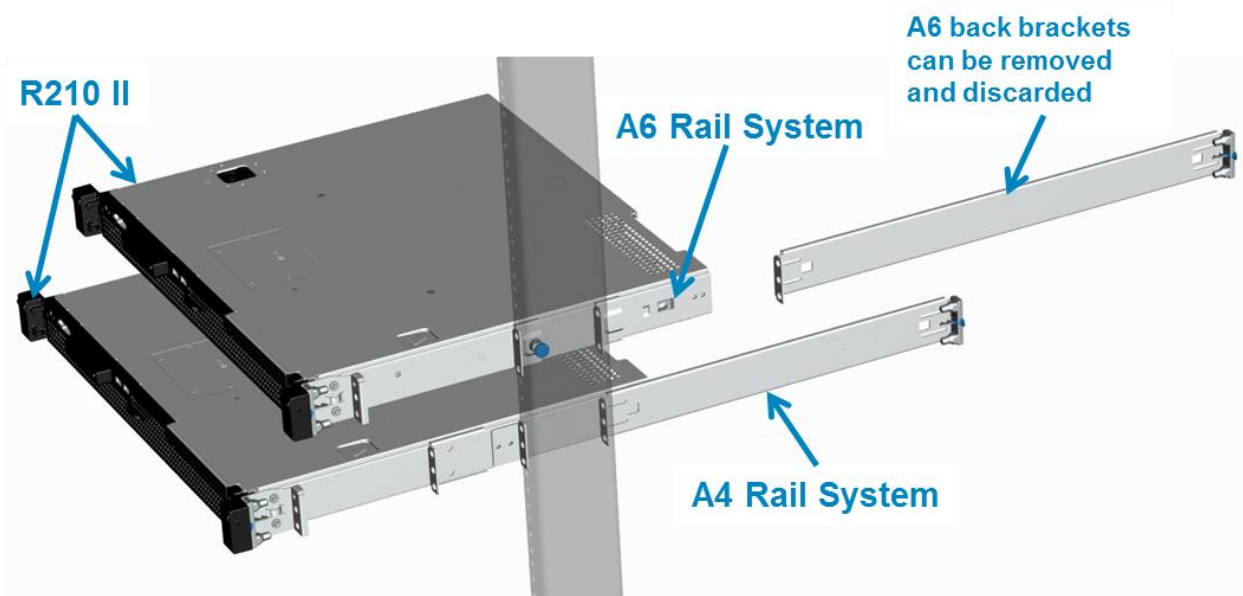

Figure 13. A4 and A6 Rail Systems in 2-post Center-Mount Configuration

Figure 14 shows the R210 II mounted in the A4 and A6 rail systems in the 2-post *flush-mount* configuration. The rear brackets on both the A4 and the A6 rail systems can be removed and discarded in this configuration, but the A4 rail system still provides the smaller mounting footprint.

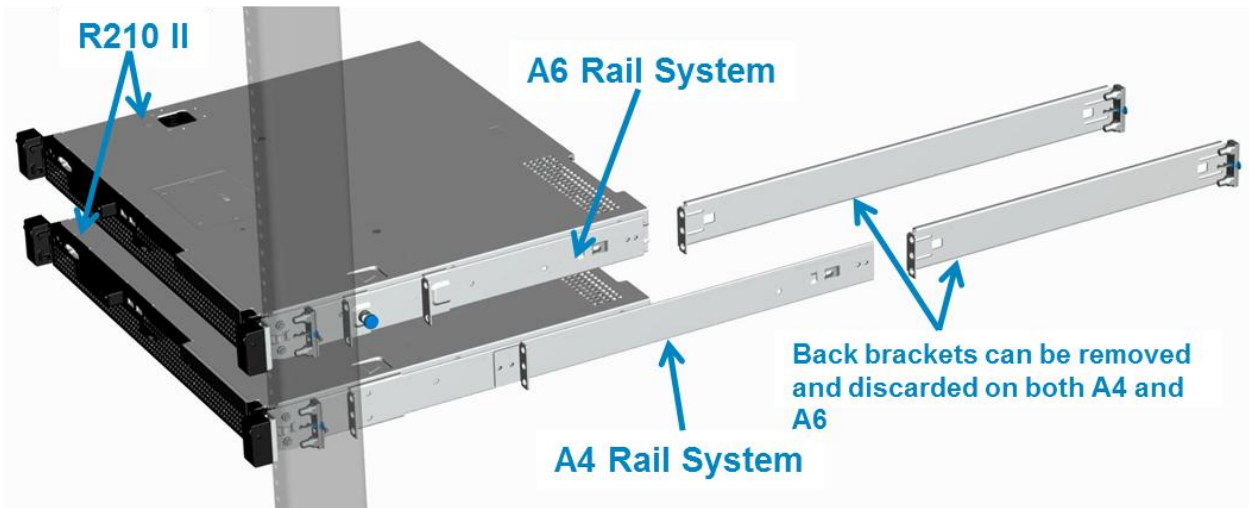

Figure 14. A4 and A6 Rail Systems in 2-post Flush-Mount Configuration

15 Operating Systems

For detailed information, see the following:

- [Operating System Support Matrix for Dell PowerEdge Systems](#) on [Dell.com](#)
- [Dell PowerEdge R210 II Getting Started Guide](#) on [Support.Dell.com](#)

16 Systems Management

16.1 Overview

Dell delivers open, comprehensive, and integrated solutions that help you reduce the complexity of managing disparate IT assets. Combining Dell PowerEdge Servers with a wide selection of Dell developed systems management solutions gives you choice and flexibility, so you can simplify and save in IT environments of any size. To help you meet your server management demands, Dell offers Dell OpenManage™ systems management solutions for:

- Deployment of one or many servers from a single console
- Monitoring of server and storage health and maintenance
- Update of system, operating system, and application software

Dell offers IT management solutions for organizations of all sizes—priced and sized appropriately and supported comprehensively.

16.2 Server Management

A Dell Systems Management and Documentation DVD and a Dell Management Console DVD are included with the product. ISO images are also available. A brief description of available content:

- **Dell Systems Build and Update Utility (SBUU):** Dell Systems Build and Update Utility assists in OS install and pre-OS hardware configuration and updates.
- **Server Update Utility (SUU):** This DVD has an inventory tool for managing updates to firmware, BIOS, and drivers for either Linux or Windows varieties.
- **OpenManage Server Administrator (OMSA):** The OpenManage Server Administrator tool provides a comprehensive, one-to-one (one console to one server) systems management solution, designed for system administrators to manage systems locally and remotely over a network. OMSA allows system administrators to focus on managing their entire network by providing comprehensive one-to-one systems management.
- **Management Console:** Dell IT Assistant (ITA) is also included, as well as tools to allow access to our remote management products. These tools are Remote Access Service for iDRAC and the Baseboard Management Controller (BMC) Utility.
- **Active Directory Snap-in Utility:** The Active Directory Snap-in Utility provides an extension snap-in to the Microsoft Active Directory. This allows you to manage Dell specific Active Directory objects. The Dell-specific schema class definitions and their installation are also included on the DVD.
- **Dell Systems Service Diagnostics Tools:** Dell Systems Service and Diagnostics tools deliver the latest Dell optimized drivers, utilities, and operating system-based diagnostics that you can use to update your system.
- **eDocs:** The section includes PDF files for PowerEdge systems, storage peripherals, and Dell OpenManage™ software.
- **Dell Management Console (DMC):** The Dell Management Console is a systems management console that enables systems administrators to discover and inventory devices on your network. It provides functions such as health and performance monitoring of networked devices and patch management capabilities for Dell systems. DMC differs from the IT Assistant management console (described above) in that with DMC, value-add plug-ins that enable advanced functionality can be purchased and added to the base DMC product.

16.3 Embedded Server Management

The PowerEdge R210 II implements circuitry for the next generation of Embedded Server Management. It is Intelligent Platform Management Interface (IPMI) v2.0 compliant. The optional iDRAC (Integrated Dell Remote Access Controller) is responsible for acting as an interface between the host system and its management software and the periphery devices. These periphery devices consist of the power supplies, the storage backplane, the integrated SAS HBA or PERC 6/I (PERC H700), and the control panel with LCD display.

The optional upgrade to iDRAC6 provides features for managing the server remotely or in data center lights-out environments.

Advanced iDRAC features require the installation of the optional iDRAC6 Enterprise card.

16.4 Dell Lifecycle Controller and Unified Server Configurator

Embedded management is comprised of several interdependent pieces:

- Dell Lifecycle Controller
- Unified Server Configurator
- iDRAC6

Dell Lifecycle Controller powers the embedded management features. It includes integrated and tamper-proof storage for system-management tools and enablement utilities (firmware, drivers, etc.). For servers with iDRAC6 Express, the Lifecycle Controller offers pre-OS server deployment, OS installation, platform updates, platform configuration, and diagnostics capabilities. For servers without iDRAC6 Express, this utility has limited functionality and offers OS installation and diagnostics capabilities only.

Dell Unified Server Configurator (USC) is a graphical user interface (GUI) that aids in local server provisioning in a pre-OS environment. To access the Unified Server Configurator, press the <F10> key within 10 seconds of the Dell logo appearance during the system boot process. Table 19 details current functionality enabled by the USC.

Table 19. Unified Server Configurator Features and Description

Feature	Description
Faster O/S Installation	Drivers and the installation utility are embedded on system, so no need to scour Dell.com.
Faster System Updates	Integration with Dell support automatically directed to latest versions of the Unified Server Configurator, iDRAC, RAID, BIOS, NIC, and Power Supply.
Update Rollback	Ability to recover to previous “known good state” for all updatable components.
More Comprehensive Diagnostics	Diagnostic utilities are embedded on system.
Simplified Hardware Configuration	Detects RAID controller and allows user to configure virtual disk and choose virtual disk as boot device, eliminating the need to launch a separate utility. Also provides configuration for iDRAC, BIOS, and NIC/LOM.

16.5 Integrated Dell Remote Access Controller

The integrated Dell Remote Access Controller (iDRAC6) provides IT Administrators comprehensive yet straightforward management of remote servers, by delivering “as if you are there” presence and control. iDRAC6 helps users to save time and money by eliminating travel to the remote server(s), whether that server is located in a different room, a different building, a different city, or in a different country. iDRAC6 is a purchasable option and is available as three offerings: iDRAC6 Express, iDRAC6 Enterprise, and Virtual Flash (vFlash) media:

- iDRAC6 Express is most appropriate for small-to-medium business customers with limited remote management needs.
- iDRAC6 Enterprise is appropriate for large data center customers with distributed servers.
- iDRAC6 with vFlash Media is provided for large enterprise customers with requirements for system management automation.

16.6 iDRAC6 Express

The optional iDRAC6 Express is the first tier of iDRAC6 upgrades. In addition to upgrading the system with a Lifecycle Controller, the iDRAC6 Express offers the following key features:

- Graphical web interface
- Standard-based interfaces
- Server Sensor monitoring and fault alerting
- Secure operation of remote access functions including authentication, authorization, and encryption
- Power control and management with the ability to limit server power consumption and remotely control server power states
- Advanced troubleshooting capabilities

For more information on iDRAC6 Express features, see Table 20.

16.7 iDRAC6 Enterprise

The optional iDRAC6 Enterprise card provides access to advanced iDRAC6 features. The iDRAC6 Enterprise connects directly to the R210 II planar and is mounted parallel to the planar with stand-offs.

Key features for the iDRAC6 Enterprise include:

- Scripting capability with Dell’s Racadm command-line
- Remote video, keyboard, and mouse control with Virtual Console
- Remote media access with Virtual Media
- Dedicated network interface

16.8 iDRAC6 Enterprise with Virtual Flash (vFlash) Media

The iDRAC6 Enterprise can be upgraded by adding the vFlash Media card. This is an 8 GB Dell-branded SD card that enables a persistent 256 MB virtual flash partition. The vFlash Media delivers the following key features:

- Support for 8 GB SD storage media
- Can be used as a repository for a pre-OS image, eliminating the need to maintain a network infrastructure for OS deployment

Dell

- Can also be used for permanent diagnostics image for use after system failures, or permanent failsafe image for periodic configuration changes

A more detailed feature list for iDRAC6 Express, iDRAC6 Enterprise, and vFlash Media is shown in Table 20.

Table 20. Features List for Base Management Functionality, iDRAC6, and vFlash

Feature	Base Management Functionality	iDRAC6 Express	iDRAC6 Enterprise	vFlash Media
Interface and Standards Support				
IPMI 2.0	✓	✓	✓	✓
Web-based GUI		✓	✓	✓
SNMP		✓	✓	✓
WSMAN		✓	✓	✓
SMASH-CLP		✓	✓	✓
Racadm command-line			✓	✓
Conductivity				
Shared/Failover Network Modes	✓	✓	✓	✓
IPv4	✓	✓	✓	✓
VLAN Tagging	✓	✓	✓	✓
IPv6		✓	✓	✓
Dynamic DNS	✓	✓	✓	✓
Dedicated NIC			✓	✓
Security and Authentication				
Role-based Authority	✓	✓	✓	✓
Local Users	✓	✓	✓	✓
Active Directory		✓	✓	✓
SSL Encryption		✓	✓	✓
Remote Management and Remediation				
Remote Firmware Update	✓	✓	✓	✓
Server power control	✓	✓	✓	✓
Serial-over-LAN (with proxy)	✓	✓	✓	✓
Serial-over-LAN (no proxy)		✓	✓	✓

Dell

Feature	Base Management Functionality	iDRAC6 Express	iDRAC6 Enterprise	vFlash Media
Power capping		✓	✓	✓
Last crash screen capture		✓	✓	✓
Boot capture		✓	✓	✓
Serial-over-LAN		✓	✓	✓
Virtual media			✓	✓
Virtual console			✓	✓
Virtual console sharing			✓	✓
Virtual flash				✓
Monitoring				
Sensor Monitoring and Alerting	✓	✓	✓	✓
Real-time Power Monitoring	✓	✓	✓	✓
Real-time Power Graphing	✓	✓	✓	✓
Historical Power Counters	✓	✓	✓	✓
Logging Features				
System Event Log	✓	✓	✓	✓
RAC Log		✓	✓	✓
Trace Log			✓	✓

17 Peripherals

The PowerEdge R210 II supports the following USB devices:

- DVD (bootable; requires two USB ports)
- USB key (bootable)
- Keyboard (only one USB keyboard is supported)
- Mouse (only one USB mouse is supported)

Appendix A. Statement of Volatility

The Dell PowerEdge R210 II contains both volatile and non-volatile (NV) components. Volatile components lose their data immediately upon removal of power from the component. Non-volatile components continue to retain their data even after the power has been removed from the component. Components chosen as user-definable configuration options (those not soldered to the motherboard) are not included in the Statement of Volatility. Configuration option information (pertinent to options such as microprocessors, system memory, remote access controllers, and storage controllers) is available by component separately. The NV components detailed in Table 21 are present in the PowerEdge R210 II server.

Table 21. Volatility Table

Server BIOS Memory	Details
Size:	64 Mbit
Type [e.g. Flash PROM, EEPROM]:	Flash EEPROM
Can user programs or operating system write data to it during normal operation?	No
Purpose? [e.g. boot code]	Boot Code and Configuration Information
How is data input to this memory?	Loading flash memory requires a vendor provided firmware file and loader program which is executed by booting up the system from a floppy or OS based executable containing the firmware file and the loader. System loaded with arbitrary data in firmware memory would not operate.
How is this memory write protected?	Software write protected
Remarks	
Server CMOS (Complementary Metal-Oxide Semiconductor) Memory	Details
Size:	512 Bytes
Type [e.g. Flash PROM, EEPROM]:	Battery backed NVRAM
Can user programs or operating system write data to it during normal operation?	No
Purpose? [e.g. boot code]	RTC & Configuration settings
How is data input to this memory?	F2 Setup Menu during POST
How is this memory write protected?	N/A

LOM (LAN [Network Interface] on Motherboard) Memory	Details:
Size:	4Mb (512KB)
Type [e.g. Flash PROM, EEPROM]:	Flash
Can user programs or operating system write data to it during normal operation?	Yes, under software control.
Purpose? [e.g. boot code]	Contains LOM boot code and configuration data
How is data input to this memory?	Requires vendor provided firmware file and loader program used during factory assembly or possible field update. A system loaded with arbitrary data in firmware memory would not operate.
How is this memory write protected?	Software control.
Remarks:	
Server System Event Log Memory / FRU	Details
Size:	4 KB
Type [e.g. Flash PROM, EEPROM]:	SEEPROM
Can user programs or operating system write data to it during normal operation?	No
Purpose? [e.g. boot code]	Store System Events
How is data input to this memory?	BMC controller write
How is this memory write protected?	Not write protected
Remarks	

TPM (Trusted Platform Module; For boards shipped outside of China; Boards sold to destinations in China do not have TPM at this time)	Details:
Size:	Unspecified size of user ROM, RAM, EEPROM; 128 bytes of OTP memory included
Type [e.g. Flash PROM, EEPROM]:	ROM, RAM, EEPROM
Can user programs or operating system write data to it during normal operation?	Yes, OS and applications that conform to the TCG standard can write data to the TPM during normal operation. Access to the NV Storage is controlled by the TPM owner.
Purpose? [e.g. boot code]	Trusted Platform Module NV storage. May be used to securely storage of encryption keys.
How is data input to this memory?	TCG TPM Specification defined command interface or Using TPM Enabled operating systems
How is this memory write protected?	As defined by the TCG TPM Specification, protection of this NV memory area is configurable by the TPM owner.
Remarks	
Server BMC (Baseboard Management Controller) Firmware Flash Memory	Details
Size:	16MB Flash
Type [e.g. Flash PROM, EEPROM]:	SPI Flash
Can user programs or operating system write data to it during normal operation?	No
Purpose? [e.g. boot code]	Stores the BMC Firmware
How is data input to this memory?	Loading flash memory requires a vendor provided firmware file and loader program which is executed by booting up the system from a floppy or OS based executable containing the firmware file and the loader. System loaded with arbitrary data in firmware memory would not operate.
How is this memory write protected?	Software write protected
Remarks	

To obtain optional component information, please refer to the Dell Statement of Volatility for the individual components. Please direct any questions to your Dell Marketing contact.

Appendix B. Certifications

B 1. Regulatory Certifications

Regulatory compliance certificates can be located at the following sites:

- <http://ausreactorprd01/reactor/xCertSearch.asp>
- http://www.dell.com/content/topics/global.aspx/about_dell/values/regulatory_compliance/dec_conform?c=us&l=en&s=corp

B 2. Product Safety Certifications

The product has been certified and bears the Mark, as applicable, of the Product Safety authorities as indicated in Table 22.

Table 22. Product Safety Certifications

Country/Region	Authority or Mark
Argentina	IRAM
Belarus	BELLIS
Canada	SCC
China	CNCA or CCC
Croatia	KONCAR
European Union	CE
Germany	TUV
IECEE	IECEE CB
Israel	SII
Kazakhstan	OTAN - CKT
Kenya	KEBS
Kuwait	KUCAS
Mexico	NYCE or NOM
Moldova	INSM
Nigeria	SONCAP
Norway	NEMKO
Russia	GOST
Saudi Arabia	KSA ICCP
South Africa	NRCS
Taiwan	BSMI
Ukraine	UKRTEST or UKRSERTCOMPUTER
United States	NRTL
Uzbekistan	STZ

B 3. Electromagnetic Compatibility

The product has been certified and bears the Mark, as applicable, of the EMC authorities as indicated in Table 23.

Table 23. Electromagnetic Compatibility Certifications

Country/Region	Authority or Mark	Class
Australia/New Zealand	ACMA or C-Tick	Class A
Belarus	BELLIS	Class A
Bosnia & Herzegovina, Montenegro, Serbia	KVALITET	Class A
Canada	ICES	Class A
China	CNCA or CCC	Class A
Croatia	KONCAR	Class A
European Union	CE	Class A
Israel	SII	Class A
Japan	VCCI	Class A
Kazakhstan	OTAN - CKT	Class A
Moldova	INSM	Class A
Norway	NEMKO	Class A
Russia	GOST	Class A
South Africa	SABS	Class A
South Korea	KCC	Class A
Taiwan	BSMI	Class A
Ukraine	UKRTEST or UKRSERTCOMPUTER	Class A
United States	FCC	Class A
Uzbekistan	STZ	Class A
Vietnam	ICT	Class A

B 4. Ergonomics, Acoustics and Hygienics

The product has been certified and bears the Mark, as applicable, of the Ergonomics, Acoustics and Hygienics authorities as indicated in Table 24.

Table 24. Ergonomics, Acoustics and Hygienics

Country/Region	Authority or Mark
Belarus	BELLIS
Germany	GS
Russia	GOST

Appendix C. Industry Standards

The PowerEdge R210 II system conforms to the industry standards detailed in Table 25.

Table 25. Industry Standards

Standard	URL for Information and Specifications
ACPI Advance Configuration and Power Interface Specification, v2.0c	http://www.acpi.info/
Energy Star EPA Version 1.0 of the Computer Server specification	http://www.energystar.gov/index.cfm?c=archives.enterprise_servers
Ethernet IEEE 802.3-2005	http://standards.ieee.org/getieee802/802.3.html
IPMI Intelligent Platform Management Interface, v2.0	http://www.intel.com/design/servers/ipmi/
DDR3 Memory DDR3 SDRAM Specification, Rev. 3A	http://www.jedec.org/download/search/JESD79-3A.pdf
LPC Low Pin Count Interface Specification, Rev. 1.1	http://developer.AMD.com/design/chipsets/industry/lpc.htm
PCI Express PCI Express Base Specification Rev. 2.0	http://www.pcisig.com/specifications/pciexpress/
PMBus Power System Management Protocol Specification, v1.1	http://pmbus.info/specs.html
SAS Serial Attached SCSI, v1.1	http://www.t10.org/cgi-bin/ac.pl?t=f&f=sas1r10.pdf
SATA Serial ATA Rev. 2.6; SATA II, Extensions to SATA 1.0a, Rev. 1.2	http://sata-io.org/
SMBIOS System Management BIOS Reference Specification, v2.6	http://www.dmtf.org/standards/smbios/
TPM Trusted Platform Module Specification, v1.2	http://www.trustedcomputinggroup.org/resources/tpm_main_specification

Standard	URL for Information and Specifications
UEFI Unified Extensible Firmware Interface Specification, v2.1	http://www.uefi.org/specs/
USB Universal Serial Bus Specification, Rev. 2.0	http://www.usb.org/developers/docs/
Windows Logo Windows Logo Program System and Device Requirements, v3.10	http://www.microsoft.com/whdc/winlogo/hwrequirements.msp