

lenovo

**Lenovo 3000 N500
Hardware Maintenance Manual**

lenovo

**Lenovo 3000 N500
Hardware Maintenance Manual**

Note

Before using this information and the product it supports, be sure to read the general information under "Notices" on page 113.

First Edition (October 2008)

© Copyright Lenovo 2008. All rights reserved.

LENOVO products, data, computer software, and services have been developed exclusively at private expense and are sold to governmental entities as commercial items as defined by 48 C.F.R. 2.101 with limited and restricted rights to use, reproduction and disclosure.

LIMITED AND RESTRICTED RIGHTS NOTICE: If products, data, computer software, or services are delivered pursuant a General Services Administration "GSA" contract, use, reproduction, or disclosure is subject to restrictions set forth in Contract No. GS-35F-05925.

© 2008 Lenovo

Contents

About this manual	v	Intermittent problems	41
		Undetermined problems	41
Safety information	1	Lenovo 3000 N500	43
General safety	2	Specifications	43
Electrical safety	3	Status indicators	45
Safety inspection guide	5	FRU tests	47
Handling devices that are sensitive to electrostatic discharge	6	Fn key combinations	48
Grounding requirements	6	FRU replacement notices	49
Safety notices: multilingual translations	7	Screw notices	49
Laser compliance statement	14	Retaining serial numbers	50
Important service information	17	Removing and replacing a FRU	53
Strategy for replacing FRUs	17	1010 Battery pack	54
Strategy for replacing a hard disk drive	18	1020 Dummy cards	55
Important notice for replacing a system board	18	1030 Hard disk drive (HDD) slot cover and HDD	56
How to use error message	18	1040 Optical drive	58
Strategy for replacing FRUs for CTO, CMV, and GAV	19	1050 Thermal slot cover	59
Product definition	19	1060 DIMM	60
FRU identification for CTO, CMV, and GAV products	19	1070 Fan assembly	61
Important information about replacing RoHS compliant FRUs	21	1080 Heat sink assembly	63
		1090 Wireless LAN card slot cover and PCI Express Mini Card for wireless LAN	65
General checkout	23	1100 CPU	67
What to do first	24	1110 Keyboard cover and power board	68
Checkout guide	25	1120 <i>Bluetooth</i> daughter card (BDC-2.1)	70
Diagnostics using PC-Doctor for DOS	26	1130 Keyboard	71
PC-Doctor for Windows	28	1140 LCD unit	73
Power system checkout	29	1150 Keyboard bezel and LED board L	76
Checking the AC adapter	29	1160 LED board R	79
Checking operational charging	29	1170 System board and ExpressCard slot assembly	80
Checking the battery pack	30	1180 Speakers and base cover	84
		2010 LCD front bezel	86
Related service information	31	2020 Inverter card	87
Restoring the factory contents by using Product Recovery discs	31	2030 Integrated camera	88
Passwords	32	2040 LCD panel, LCD cable, and hinges	89
Power-on password	32	2050 Antenna assembly and LCD cover	92
Hard-disk password	32	Locations	93
Supervisor password	33	Front view	93
How to remove the hard-disk password	33	Rear view	95
Power management	34	Bottom view	95
Screen blank mode	34	Parts list	96
Sleep (standby) mode	34	Overall	97
Hibernation mode	35	LCD FRUs	101
Symptom-to-FRU index	36	Keyboard	103
Numeric error codes	36	Miscellaneous parts	104
Error messages	38	AC adapters	105
Beep symptoms	39	Power cords	106
No-beep symptoms	39	Recovery discs	107
LCD-related symptoms	40	Common service tools	111
		Notices	113
		Trademarks	114

About this manual

This manual contains service and reference information for the following Lenovo 3000 products.

Lenovo 3000 N500
MT 4233

Use this manual along with the advanced diagnostic tests to troubleshoot problems.

The manual is divided into sections as follows:

- The common sections provide general information, guidelines, and safety information required in servicing computers.
- The product-specific section includes service, reference, and product-specific parts information.

Important:

This manual is intended only for trained servicers who are familiar with Lenovo 3000 products. Use this manual along with the advanced diagnostic tests to troubleshoot problems effectively.

Before servicing a Lenovo 3000 product, be sure to read all the information under "Safety information" on page 1 and "Important service information" on page 17.

Safety information

This chapter presents following safety information that you need to be familiar with before you service a Lenovo 3000 computer.

- "General safety" on page 2
- "Electrical safety" on page 3
- "Safety inspection guide" on page 5
- "Handling devices that are sensitive to electrostatic discharge" on page 6
- "Grounding requirements" on page 6
- "Safety notices: multilingual translations" on page 7
- "Laser compliance statement" on page 14

General safety

Follow these rules to ensure general safety:

- Observe good housekeeping in the area of the machines during and after maintenance.
- When lifting any heavy object:
 1. Make sure that you can stand safely without slipping.
 2. Distribute the weight of the object equally between your feet.
 3. Use a slow lifting force. Never move suddenly or twist when you attempt to lift.
 4. Lift by standing or by pushing up with your leg muscles; this action removes the strain from the muscles in your back. *Do not attempt to lift any object that weighs more than 16 kg (35 lb) or that you think is too heavy for you.*
- Do not perform any action that causes hazards to the customer, or that makes the equipment unsafe.
- Before you start the machine, make sure that other service representatives and the customer's personnel are not in a hazardous position.
- Place removed covers and other parts in a safe place, away from all personnel, while you are servicing the machine.
- Keep your toolcase away from walk areas so that other people will not trip over it.
- Do not wear loose clothing that can be trapped in the moving parts of a machine. Make sure that your sleeves are fastened or rolled up above your elbows. If your hair is long, fasten it.
- Insert the ends of your necktie or scarf inside clothing or fasten it with a nonconductive clip, about 8 centimeters (3 inches) from the end.
- Do not wear jewelry, chains, metal-frame eyeglasses, or metal fasteners for your clothing.

Attention: Metal objects are good electrical conductors.
- Wear safety glasses when you are hammering, drilling, soldering, cutting wire, attaching springs, using solvents, or working in any other conditions that might be hazardous to your eyes.
- After service, reinstall all safety shields, guards, labels, and ground wires. Replace any safety device that is worn or defective.
- Reinstall all covers correctly before returning the machine to the customer.
- Fan louvers on the machine help to prevent overheating of internal components. Do not obstruct fan louvers or cover them with labels or stickers.

Electrical safety

Observe the following rules when working on electrical equipment.

Important:

Use only approved tools and test equipment. Some hand tools have handles covered with a soft material that does not insulate you when working with live electrical currents.

Many customers have, near their equipment, rubber floor mats that contain small conductive fibers to decrease electrostatic discharges. Do not use this type of mat to protect yourself from electrical shock.

- Find the room emergency power-off (EPO) switch, disconnecting switch, or electrical outlet. If an electrical accident occurs, you can then operate the switch or unplug the power cord quickly.
 - Do not work alone under hazardous conditions or near equipment that has hazardous voltages.
 - Disconnect all power before:
 - Performing a mechanical inspection
 - Working near power supplies
 - Removing or installing main units
 - Before you start to work on the machine, unplug the power cord. If you cannot unplug it, ask the customer to power-off the wall box that supplies power to the machine, and to lock the wall box in the off position.
 - If you need to work on a machine that has *exposed* electrical circuits, observe the following precautions:
 - Ensure that another person, familiar with the power-off controls, is near you.

Attention: Another person must be there to switch off the power, if necessary.
 - Use only one hand when working with powered-on electrical equipment; keep the other hand in your pocket or behind your back.

Attention: An electrical shock can occur only when there is a complete circuit. By observing the above rule, you may prevent a current from passing through your body.
 - When using testers, set the controls correctly and use the approved probe leads and accessories for that tester.
 - Stand on suitable rubber mats (obtained locally, if necessary) to insulate you from grounds such as metal floor strips and machine frames.
- Observe the special safety precautions when you work with very high voltages; Instructions for these precautions are in the safety sections of maintenance information. Use extreme care when measuring high voltages.
- Regularly inspect and maintain your electrical hand tools for safe operational condition.
 - Do not use worn or broken tools and testers.
 - *Never assume* that power has been disconnected from a circuit. First, *check* that it has been powered off.
 - Always look carefully for possible hazards in your work area. Examples of these hazards are moist floors, nongrounded power extension cables, power surges, and missing safety grounds.

- Do not touch live electrical circuits with the reflective surface of a plastic dental mirror. The surface is conductive; such touching can cause personal injury and machine damage.
- Do not service the following parts *with the power on* when they are removed from their normal operating places in a machine:
 - Power supply units
 - Pumps
 - Blowers and fans
 - Motor generators

and similar units. (This practice ensures correct grounding of the units.)

- If an electrical accident occurs:
 - Use caution; do not become a victim yourself.
 - Switch off power.
 - Send another person to get medical aid.

Safety inspection guide

The purpose of this inspection guide is to assist you in identifying potentially unsafe conditions. As each machine was designed and built, required safety items were installed to protect users and service personnel from injury. This guide addresses only those items. You should use good judgment to identify potential safety hazards due to attachment of non-Lenovo 3000 features or options not covered by this inspection guide.

If any unsafe conditions are present, you must determine how serious the apparent hazard could be and whether you can continue without first correcting the problem.

Consider these conditions and the safety hazards they present:

- Electrical hazards, especially primary power (primary voltage on the frame can cause serious or fatal electrical shock)
- Explosive hazards, such as a damaged CRT face or a bulging capacitor
- Mechanical hazards, such as loose or missing hardware

To determine whether there are any potentially unsafe conditions, use the following checklist at the beginning of every service task. Begin the checks with the power off, and the power cord disconnected.

Checklist:

1. Check exterior covers for damage (loose, broken, or sharp edges).
2. Power off the computer. Disconnect the power cord.
3. Check the power cord for:
 - a. A third-wire ground connector in good condition. Use a meter to measure third-wire ground continuity for 0.1 ohm or less between the external ground pin and the frame ground.
 - b. The power cord should be the type specified in the parts list.
 - c. Insulation must not be frayed or worn.
4. Check for cracked or bulging batteries.
5. Remove the cover.
6. Check for any obvious non-Lenovo 3000 alterations. Use good judgment as to the safety of any non-Lenovo 3000 alterations.
7. Check inside the unit for any obvious unsafe conditions, such as metal filings, contamination, water or other liquids, or signs of fire or smoke damage.
8. Check for worn, frayed, or pinched cables.
9. Check that the power-supply cover fasteners (screws or rivets) have not been removed or tampered with.

Handling devices that are sensitive to electrostatic discharge

Any computer part containing transistors or integrated circuits (ICs) should be considered sensitive to electrostatic discharge (ESD.) ESD damage can occur when there is a difference in charge between objects. Protect against ESD damage by equalizing the charge so that the machine, the part, the work mat, and the person handling the part are all at the same charge.

Notes:

1. Use product-specific ESD procedures when they exceed the requirements noted here.
2. Make sure that the ESD protective devices you use have been certified (ISO 9000) as fully effective.

When handling ESD-sensitive parts:

- Keep the parts in protective packages until they are inserted into the product.
- Avoid contact with other people.
- Wear a grounded wrist strap against your skin to eliminate static on your body.
- Prevent the part from touching your clothing. Most clothing is insulative and retains a charge even when you are wearing a wrist strap.
- Use the black side of a grounded work mat to provide a static-free work surface. The mat is especially useful when handling ESD-sensitive devices.
- Select a grounding system, such as those listed below, to provide protection that meets the specific service requirement.

Note:

The use of a grounding system to guard against ESD damage is desirable but not necessary.

- Attach the ESD ground clip to any frame ground, ground braid, or green-wire ground.
- When working on a double-insulated or battery-operated system, use an ESD common ground or reference point. You can use coax or connector-outside shells on these systems.
- Use the round ground prong of the ac plug on ac-operated computers.

Grounding requirements

Electrical grounding of the computer is required for operator safety and correct system function. Proper grounding of the electrical outlet can be verified by a certified electrician.

Safety notices: multilingual translations

The safety notices in this section are provided in English, French, German, Hebrew, Italian, Japanese, and Spanish.

Safety notice 1

Before the computer is powered on after FRU replacement, make sure all screws, springs, and other small parts are in place and are not left loose inside the computer. Verify this by shaking the computer and listening for rattling sounds. Metallic parts or metal flakes can cause electrical shorts.

Avant de remettre l'ordinateur sous tension après remplacement d'une unité en clientèle, vérifiez que tous les ressorts, vis et autres pièces sont bien en place et bien fixées. Pour ce faire, secouez l'unité et assurez-vous qu'aucun bruit suspect ne se produit. Des pièces métalliques ou des copeaux de métal pourraient causer un court-circuit.

Bevor nach einem FRU-Austausch der Computer wieder angeschlossen wird, muß sichergestellt werden, daß keine Schrauben, Federn oder andere Kleinteile fehlen oder im Gehäuse vergessen wurden. Der Computer muß geschüttelt und auf Klappergeräusche geprüft werden. Metallteile oder-splitter können Kurzschlüsse erzeugen.

לפני הפעלת המחשב לאחר החלפת FRU יש לוודא שכל הברגים, הקפיצים, וחלקים קטנים אחרים נמצאים במקומם ואינם חופשיים לזוז בתוך המחשב. כדי לוודא זאת, יש לטלטל את המחשב ולהקשיב לגילוי קולות שקשוק. חלקי או שבבי מתכת עלולים לגרום לקצרים חשמליים.

Prima di accendere l'elaboratore dopo che é stata effettuata la sostituzione di una FRU, accertarsi che tutte le viti, le molle e tutte le altre parti di piccole dimensioni siano nella corretta posizione e non siano sparse all'interno dell'elaboratore. Verificare ciò scuotendo l'elaboratore e prestando attenzione ad eventuali rumori; eventuali parti o pezzetti metallici possono provocare cortocircuiti pericolosi.

FRUの交換後、ThinkPadの電源を入れる前に、ねじ、バネ、その他の小さな部品がすべて正しい位置にあり、またThinkPadの内部で緩んでいないことを確認してください。これを確認するには、ThinkPadを振って、カチャカチャと音がしないか確かめます。金属部品や金属破片はショートの原因になることがあります。

Antes de encender el sistema despues de sustituir una FRU, compruebe que todos los tornillos, muelles y demás piezas pequeñas se encuentran en su sitio y no se encuentran sueltas dentro del sistema. Compruébelo agitando el sistema y escuchando los posibles ruidos que provocarían. Las piezas metálicas pueden causar cortocircuitos eléctricos.

Safety notice 2



Some standby batteries contain a small amount of nickel and cadmium. Do not disassemble a standby battery, recharge it, throw it into fire or water, or short-circuit it. Dispose of the battery as required by local ordinances or regulations. Use only the battery in the appropriate parts listing. Use of an incorrect battery can result in ignition or explosion of the battery.

Certaines batteries de secours contiennent du nickel et du cadmium. Ne les démontez pas, ne les rechargez pas, ne les exposez ni au feu ni à l'eau. Ne les mettez pas en court-circuit. Pour les mettre au rebut, conformez-vous à la réglementation en vigueur. Lorsque vous remplacez la pile de sauvegarde ou celle de l'horloge temps réel, veillez à n'utiliser que les modèles cités dans la liste de pièces détachées adéquate. Une batterie ou une pile inappropriée risque de prendre feu ou d'exploser.

Die Bereitschaftsbatterie, die sich unter dem Diskettenlaufwerk befindet, kann geringe Mengen Nickel und Cadmium enthalten. Sie darf nur durch die Verkaufsstelle oder den IBM Kundendienst ausgetauscht werden. Sie darf nicht zerlegt, wiederaufgeladen, kurzgeschlossen, oder Feuer oder Wasser ausgesetzt werden. Die Batterie kann schwere Verbrennungen oder Verätzungen verursachen. Bei der Entsorgung die örtlichen Bestimmungen für Sondermüll beachten. Beim Ersetzen der Bereitschafts- oder Systembatterie nur Batterien des Typs verwenden, der in der Ersatzteilliste aufgeführt ist. Der Einsatz falscher Batterien kann zu Entzündung oder Explosion führen.

סוללות המתנה מסוימות מכילות כמות קטנה של ניקל וקדמיום. אין לפרק סוללת המתנה, לטעון אותה מחדש, להשליך אותה לאש או למים או לקצר אותה. יש לסלק את הסוללה כנדרש על ידי התקנות והחוקים המקומיים. יש להשתמש רק בסוללה המופיעה ברשימת החלקים המתאימה. שימוש בסוללה לא מתאימה עלול לגרום להצתה או התפוצצות של הסוללה.

Alcune batterie di riserva contengono una piccola quantità di nichel e cadmio. Non smontarle, ricaricarle, gettarle nel fuoco o nell'acqua né cortocircuitarle. Smaltirle secondo la normativa in vigore (DPR 915/82, successive disposizioni e disposizioni locali). Quando si sostituisce la batteria dell'RTC (real time clock) o la batteria di supporto, utilizzare soltanto i tipi inseriti nell'appropriato Catalogo parti. L'impiego di una batteria non adatta potrebbe determinare l'incendio o l'esplosione della batteria stessa.

予備バッテリーの中には少量のニッケルとカドミウムが含まれているものがあります。したがって、予備バッテリーの分解、再充電、火または水の中への投棄、またはショートさせることは決して行わないでください。バッテリーを廃棄する場合は地方自治体の条例に従ってください。適切なパーツ・リストにあるバッテリーだけを使用してください。誤ったバッテリーを使用すると、バッテリーが発火したり、爆発したりすることがあります。

Algunas baterías de reserva contienen una pequeña cantidad de níquel y cadmio. No las desmonte, ni recargue, ni las eche al fuego o al agua ni las cortocircuite. Deséchelas tal como dispone la normativa local. Utilice sólo baterías que se encuentren en la lista de piezas. La utilización de una batería no apropiada puede provocar la ignición o explosión de la misma.

Safety notice 3



The battery pack contains small amounts of nickel. Do not disassemble it, throw it into fire or water, or short-circuit it. Dispose of the battery pack as required by local ordinances or regulations. Use only the battery in the appropriate parts listing when replacing the battery pack. Use of an incorrect battery can result in ignition or explosion of the battery.

La batterie contient du nickel. Ne la démontez pas, ne l'exposez ni au feu ni à l'eau. Ne la mettez pas en court-circuit. Pour la mettre au rebut, conformez-vous à la réglementation en vigueur. Lorsque vous remplacez la batterie, veillez à n'utiliser que les modèles cités dans la liste de pièces détachées adéquate. En effet, une batterie inappropriée risque de prendre feu ou d'exploser.

Akkus enthalten geringe Mengen von Nickel. Sie dürfen nicht zerlegt, wiederaufgeladen, kurzgeschlossen, oder Feuer oder Wasser ausgesetzt werden. Bei der Entsorgung die örtlichen Bestimmungen für Sondermüll beachten. Beim Ersetzen der Batterie nur Batterien des Typs verwenden, der in der Ersatzteilliste aufgeführt ist. Der Einsatz falscher Batterien kann zu Entzündung oder Explosion führen.

מארז הסוללה מכיל כמות קטנה של ניקל
וקדמיים. אין לפרק את מארז הסוללה, להשליך
אותו לאש או למים או לקצר אותו. יש לסלק את
מארז הסוללה הסוללה כנדרש על ידי התקנות
והחוקים המקומיים. יש להשתמש רק בסוללה
המופיעה ברשימת החלקים המתאימה בזמן החלפת
מארז הסוללה. שימוש בסוללה לא מתאימה עלול
לגרום להצתה או התפוצצות של הסוללה.

La batteria contiene piccole quantità di nichel. Non smontarla, gettarla nel fuoco o nell'acqua né cortocircuitarla. Smaltirla secondo la normativa in vigore (DPR 915/82, successive disposizioni e disposizioni locali). Quando si sostituisce la batteria, utilizzare soltanto i tipi inseriti nell'appropriato Catalogo parti. L'impiego di una batteria non adatta potrebbe determinare l'incendio o l'esplosione della batteria stessa.

バッテリー・パックには少量のニッケルが含まれています。バッテリー・パックを分解したり、火または水の中に投げ込んだり、ショートさせないでください。バッテリー・パックの廃棄にあたっては、地方自治体の条例または規則に従ってください。バッテリー・パックを交換するときは、適切なパーツ・リストにあるバッテリーだけを使用してください。誤ったバッテリーを使用すると、バッテリーが発火したり、爆発したりすることがあります。

Las baterías contienen pequeñas cantidades de níquel. No las desmonte, ni recargue, ni las eche al fuego o al agua ni las cortocircuite. Deséchelas tal como dispone la normativa local. Utilice sólo baterías que se encuentren en la lista de piezas al sustituir la batería. La utilización de una batería no apropiada puede provocar la ignición o explosión de la misma.

Safety notice 4



The lithium battery can cause a fire, an explosion, or a severe burn. Do not recharge it, remove its polarized connector, disassemble it, heat it above 100°C (212°F), incinerate it, or expose its cell contents to water. Dispose of the battery as required by local ordinances or regulations. Use only the battery in the appropriate parts listing. Use of an incorrect battery can result in ignition or explosion of the battery.

La pile de sauvegarde contient du lithium. Elle présente des risques d'incendie, d'explosion ou de brûlures graves. Ne la rechargez pas, ne retirez pas son connecteur polarisé et ne la démontez pas. Ne l'exposez pas à une température supérieure à 100°C, ne la faites pas brûler et n'en exposez pas le contenu à l'eau. Mettez la pile au rebut conformément à la réglementation en vigueur. Une pile inappropriée risque de prendre feu ou d'exploser.

Die Systematterie ist eine Lithiumatterie. Sie kann sich entzünden, explodieren oder schwere Verbrennungen hervorrufen. Batterien dieses Typs dürfen nicht aufgeladen, zerlegt, über 100 C erhitzt oder verbrannt werden. Auch darf ihr Inhalt nicht mit Wasser in Verbindung gebracht oder der zur richtigen Polung angebrachte Verbindungsstecker entfernt werden. Bei der Entsorgung die örtlichen Bestimmungen für Sondermüll beachten. Beim Ersetzen der Batterie nur Batterien des Typs verwenden, der in der Ersatzteilliste aufgeführt ist. Der Einsatz falscher Batterien kann zu Entzündung oder Explosion führen.

סוללת הליתיום עלולה לגרום לשריפה, להתפוצצות או לכוויות קשות. אין לטעון אותה מחדש, לסלק את המחבר המקוטב שלה, לפרק אותה או לחמם אותה לטמפרטורה העולה על 100 מעלות צלזיוס. אין לשרוף את הסוללה ואין לחשוף את תוכן התא למים. יש לסלק את הסוללה בנדרש בתקנות ובחוקים המקומיים. יש להשתמש רק בסוללה המופיעה ברשימת החלקים המתאימים. שימוש בסוללה אחרת עלול לגרום לסכנת שריפה או התפוצצות.

La batteria di supporto e una batteria al litio e puo incendiarsi, esplodere o procurare gravi ustioni. Evitare di ricaricarla, smontarne il connettore polarizzato, smontarla, riscaldarla ad una temperatura superiore ai 100 gradi centigradi, incendiarla o gettarla in acqua. Smaltirla secondo la normativa in vigore (DPR 915/82, successive disposizioni e disposizioni locali). L'impiego di una batteria non adatta potrebbe determinare l'incendio o l'esplosione della batteria stessa.

リチウム・バッテリーは、火災、爆発、または重症のやけどを引き起こすことがあります。バックアップ・バッテリーの充電、その極性コネクタの取り外し、バッテリー本体の分解、100°C (212°F) 以上への加熱、焼却、電池の中身を水に浸すことはしないでください。バッテリーを廃棄する場合は地方自治体の条例に従ってください。適切なパーツ・リストにあるバッテリーだけを使用してください。誤ったバッテリーを使用すると、バッテリーが発火したり、爆発したりすることがあります。

La batería de repuesto es una batería de litio y puede provocar incendios, explosiones o quemaduras graves. No la recargue, ni quite el conector polarizado, ni la desmonte, ni caliente por encima de los 100°C (212°F), ni la incinere ni exponga el contenido de sus celdas al agua. Deséchela tal como dispone la normativa local.

Safety notice 5

If the LCD breaks and the fluid from inside the LCD gets into your eyes or on your hands, immediately wash the affected areas with water for at least 15 minutes. Seek medical care if any symptoms from the fluid are present after washing.

Si le panneau d'affichage à cristaux liquides se brise et que vous recevez dans les yeux ou sur les mains une partie du fluide, rincez-les abondamment pendant au moins quinze minutes. Consultez un médecin si des symptômes persistent après le lavage.

Die Leuchtstoffröhre im LCD-Bildschirm enthält Quecksilber. Bei der Entsorgung die örtlichen Bestimmungen für Sondermüll beachten. Der LCD-Bildschirm besteht aus Glas und kann zerbrechen, wenn er unsachgemäß behandelt wird oder der Computer auf den Boden fällt. Wenn der Bildschirm beschädigt ist und die darin befindliche Flüssigkeit in Kontakt mit Haut und Augen gerät, sollten die betroffenen Stellen mindestens 15 Minuten mit Wasser abgespült und bei Beschwerden anschließend ein Arzt aufgesucht werden.

אם מסך הגביש הנוזלי (LCD) נשבר והנוזל מתוך המסך בא במגע עם עיניכם או ידיכם, שטפו את האזורים הנגועים מיד במים במשך 15 דקות לפחות. מנו לקבלת עזרה רפואית אם תסמינים הנובעים מהמגע עם הנוזל נמשכים לאחר השטיפה.

Nel caso che caso l'LCD si dovesse rompere ed il liquido in esso contenuto entrasse in contatto con gli occhi o le mani, lavare immediatamente le parti interessate con acqua corrente per almeno 15 minuti; poi consultare un medico se i sintomi dovessero permanere.

LCD が破損し、LCD 中の液体が目に入ったり、手に触れたりした場合は、液体が触れた部分を少なくとも 15 分間洗い流してください。洗い流した後に、液体によって何らかの症状が現れた場合は、医師の治療を受けてください。

Si la LCD se rompe y el fluido de su interior entra en contacto con sus ojos o sus manos, lave inmediatamente las áreas afectadas con agua durante 15 minutos como mínimo. Obtenga atención medica si se presenta algún síntoma del fluido despues de lavarse.

Safety notice 6

DANGER

To avoid shock, do not remove the plastic cover that protects the lower part of the inverter card.

Afin d'éviter tout risque de choc électrique, ne retirez pas le cache en plastique protégeant la partie inférieure de la carte d'alimentation.

Aus Sicherheitsgründen die Kunststoffabdeckung, die den unteren Teil der Spannungswandlerplatine umgibt, nicht entfernen.

כדי למנוע התחשמלות, אין להסיר את מכסה הפלסטיק המגן על חלקו התחתון של הכרטיס ההפוך.

Per evitare scosse elettriche, non rimuovere la copertura in plastica che avvolge la parte inferiore della scheda invertitore.

感電を防ぐため、インバーター・カードの下部を保護しているプラスチック・カバーを外さないでください。

Para evitar descargas, no quite la cubierta de plástico que rodea la parte baja de la tarjeta invertida.

Safety notice 7

DANGER

Though the main batteries have low voltage, a shorted or grounded battery can produce enough current to burn personnel or combustible materials.

Bien que le voltage des batteries principales soit peu élevé, le court-circuit ou la mise à la masse d'une batterie peut produire suffisamment de courant pour brûler des matériaux combustibles ou causer des brûlures corporelles graves.

Obwohl Hauptbatterien eine niedrige Spannung haben, können sie doch bei Kurzschluß oder Erdung genug Strom abgeben, um brennbare Materialien zu entzünden oder Verletzungen bei Personen hervorzurufen.

אף שהסוללות הראשיות הן בעלות מתח נמוך, סוללה מקוצרת או מוארקת עלולה להפיק זרם מספיק לגרימת כוויות או להצתת חומרים דליקים.

Sebbene le batterie di alimentazione siano a basso voltaggio, una batteria in corto circuito o a massa può fornire corrente sufficiente da bruciare materiali combustibili o provocare ustioni ai tecnici di manutenzione.

メイン・バッテリーの電圧は低くても、ショートしたり、接地したバッテリーが、作業者にやけどを負わせたり、可燃物を燃やすだけの電流を発生させる場合があります。

Aunque las baterías principales tienen un voltaje bajo, una batería cortocircuitada o con contacto a tierra puede producir la corriente suficiente como para quemar material combustible o provocar quemaduras en el personal.

Safety notice 8

DANGER

Before removing any FRU, power off the computer, unplug all power cords from electrical outlets, remove the battery pack, and then disconnect any interconnecting cables.

Avant de retirer une unité remplaçable en clientèle, mettez le système hors tension, débranchez tous les cordons d'alimentation des socles de prise de courant, retirez la batterie et déconnectez tous les cordons d'interface.

Die Stromzufuhr muß abgeschaltet, alle Stromkabel aus der Steckdose gezogen, der Akku entfernt und alle Verbindungskabel abgenommen sein, bevor eine FRU entfernt wird.

לפני סילוק FRU כלשהו, יש לכבות את המחשב, לנתק את כל כבלי החשמל משקעי החשמל, להוציא את מארז הסוללה, ואז לנתק כבלי חיבור אחרים אם יש כאלה.

Prima di rimuovere qualsiasi FRU, spegnere il sistema, scollegare dalle prese elettriche tutti i cavi di alimentazione, rimuovere la batteria e poi scollegare i cavi di interconnessione.

FRU を取り外す前に、ThinkPad の電源を切って、すべての電源コードをコンセントから外してください。次に、バッテリー・パックを外し、相互接続ケーブルを外してください。

Antes de quitar una FRU, apague el sistema, desenchufe todos los cables de las tomas de corriente eléctrica, quite la batería y, a continuación, desconecte cualquier cable de conexión entre dispositivos.

Laser compliance statement

Some models of Lenovo 3000 computer are equipped from the factory with an optical storage device such as a CD-ROM drive or a DVD-ROM drive. Such devices are also sold separately as options. If one of these drives is installed, it is certified in the U.S. to conform to the requirements of the Department of Health and Human Services 21 Code of Federal Regulations (DHHS 21 CFR) Subchapter J for Class 1 laser products. Elsewhere, the drive is certified to conform to the requirements of the International Electrotechnical Commission (IEC) 825 and CENELEC EN 60 825 for Class 1 laser products.

If a CD-ROM drive, a DVD-ROM drive, or another laser device is installed, note the following:

 **CAUTION:**

Use of controls or adjustments or performance of procedures other than those specified herein might result in hazardous radiation exposure.

O uso de controles, ajustes ou desempenho de procedimentos diferentes daqueles aqui especificados pode resultar em perigosa exposição à radiação.

凡未在这里指明的任何控制用法、调整、行为，都会导致严重后果。

Pour éviter tout risque d'exposition au rayon laser, respectez les consignes de réglage et d'utilisation des commandes, ainsi que les procédures décrites.

Werden Steuer- und Einstellelemente anders als hier festgesetzt verwendet, kann gefährliche Laserstrahlung auftreten.

Az itt előírt eljárásoktól, beállítástól és vezérlésektől eltérni a lézersugárzás veszélye miatt kockázatos!

L'utilizzo di controlli, regolazioni o l'esecuzione di procedure diverse da quelle specificate possono provocare l'esposizione a.

Использование элементов настройки и выполнение процедур иных, чем указано здесь, может привести к опасному радиационному облучению.

Použitie kontrol, úprav alebo iných vykonaní od iných výrobcov, ako je v tomto špecifikované, mohlo by mať za následok nebezpečenstvo vystavenia sa vyžiarovaniu.

本書で指定された内容以外の、お客様による整備、調整、または手順を行った場合、レーザー光の放射の危険があります。

El uso de controles o ajustes o la ejecución de procedimientos distintos de los aquí especificados puede provocar la exposición a radiaciones peligrosas.

Opening the CD-ROM drive, the DVD-ROM drive, or any other optical storage device could result in exposure to hazardous laser radiation. There are no serviceable parts inside those drives. **Do not open.**

A CD-ROM drive, a DVD-ROM drive, or any other storage device installed may contain an embedded Class 3A or Class 3B laser diode. Note the following:

 **DANGER**

Emits visible and invisible laser radiation when open. Do not stare into the beam, do not view directly with optical instruments, and avoid direct exposure to the beam.

Radiação por raio laser ao abrir. Não olhe fixo no feixe de luz, não olhe diretamente por meio de instrumentos óticos e evite exposição direta com o feixe de luz.

开启时会有激光发射时，请勿盯视激光光束，请勿直接查看视觉仪器，并且避免直接接触在激光光束之中。

Rayonnement laser si carter ouvert. Évitez de fixer le faisceau, de le regarder directement avec des instruments optiques, ou de vous exposer au rayon.

Laserstrahlung bei geöffnetem Gerät. Nicht direkt oder über optische Instrumente in den Laserstrahl sehen und den Strahlungsbereich meiden.

Kinyitáskor lézersugár ! Ne nézzen bele se szabad szemmel, se optikai eszközökkel. Kerülje a sugárnyalábbal való érintkezést !.

Aperto l'unità vengono emesse radiazioni laser. Non fissare il fascio, non guardarlo direttamente con strumenti ottici e evitare l'esposizione diretta al fascio.

Открывая, берегитесь лазерного излучения.
Не смотрите на луч, не разглядывайте его с помощью оптических инструментов, а также избегайте прямого воздействия лазерного луча.

Keď je laserová jednotka otvorená. Vyhňte sa priamemu pohľadu a nehľadte priamo s optickými nástrojmi do lúča a vyhňte sa priamemu vystaveniu lúčov.

開けるとレーザー光が放射されます。光線を見つめたり、光学機械を使って直接見たりしないでください。

Radiación láser al abrir. No mire fijamente ni examine con instrumental óptico el haz de luz. Evite la exposición directa al haz.

Important service information

This chapter presents following important service information:

- “Strategy for replacing FRUs”
 - “Strategy for replacing a hard disk drive” on page 18
 - “Important notice for replacing a system board” on page 18
 - “How to use error message” on page 18
- “Strategy for replacing FRUs for CTO, CMV, and GAV” on page 19
 - “Product definition” on page 19
 - “FRU identification for CTO, CMV, and GAV products” on page 19
- “Important information about replacing RoHS compliant FRUs” on page 21

Important:

BIOS and device driver fixes are customer-installable. The BIOS and device drivers are posted on the customer support site <http://www.lenovo.com/support>

System Disassembly/Reassembly videos that show the FRU removals or replacements for the Lenovo® authorized service technicians are available in the following support site: <http://www.lenovoservicetraining.com/ion/>

Advise customers to contact the Customer Support Center at 800-426-7378 if they need assistance in obtaining or installing any software fixes, drivers, and BIOS downloads.

Customers in Canada should call the Customer Support Center at 800-565-3344 for assistance or download information.

Strategy for replacing FRUs

Before replacing parts:

Make sure that all software fixes, drivers, and BIOS downloads are installed before replacing any FRUs listed in this manual.

After a system board is replaced, ensure that the latest BIOS is loaded to the system board before completing the service action.

To download software fixes, drivers, and BIOS, do as follows:

1. Go to <http://www.lenovo.com/support>
2. Enter the product number of the computer or press Auto-detect button on the screen.
3. Select **Downloads and drivers**.
4. Follow the directions on the screen and install the necessary software.

Use the following strategy to prevent unnecessary expense for replacing and servicing FRUs:

- **If you are instructed to replace a FRU but the replacement does not correct the problem, reinstall the original FRU before you continue.**
- Some computers have both a processor board and a system board. If you are instructed to replace either the processor board or the system board, and replacing one of them does not correct the problem, reinstall that board, and then replace the other one.
- If an adapter or a device consists of more than one FRU, any of the FRUs may be the cause of the error. Before replacing the adapter or device, remove the FRUs, one by one, to see if the symptoms change. Replace only the FRU that changed the symptoms.

Attention: The setup configuration on the computer you are servicing may have been customized. Running Automatic Configuration may alter the settings. Note the current configuration settings (using the View Configuration option); then, when service has been completed, verify that those settings remain in effect.

Strategy for replacing a hard disk drive

Always try to run a low-level format before replacing a hard disk drive. This will cause all customer data on the hard disk to be lost. Be sure that the customer has a current backup of the data before doing this task.

Attention: The drive startup sequence in the computer you are servicing may have been changed. Be extremely careful during write operations such as copying, saving, or formatting. If you select an incorrect drive, data or programs can be overwritten.

Important notice for replacing a system board

Some components mounted on a system board are very sensitive. Improper handling of a system board can cause damage to those components, and may cause a system malfunction.

Attention: When handling a system board:

- Do not drop a system board or apply any excessive force to it.
- Avoid rough handling of any kind.
- Avoid bending a system board and hard pushing to prevent cracking at each BGA (Ball Grid Array) chipset.

How to use error message

Use the error codes displayed on the screen to diagnose failures. If more than one error code is displayed, begin the diagnosis with the first error code. Whatever causes the first error code may also cause false error codes. If no error code is displayed, see whether the error symptom is listed in the Symptom-to-FRU Index for the computer you are servicing.

Strategy for replacing FRUs for CTO, CMV, and GAV

Product definition

Dynamic Configure To Order (CTO)

This provides the ability for a customer to configure an IBM® or a Lenovo solution from an eSite, and have this configuration sent to fulfillment, where it is built and shipped directly to the customer. The machine label, Product Entitlement Warehouse (PEW), eSupport, and the HMM will load these products as the 4-digit MT and 3-digit model, where model = "CTO" (Example: 1829-CTO).

Custom Model Variant (CMV)

This is a unique configuration that has been negotiated between IBM or Lenovo and the customer. A unique 4-digit MT and 3-digit model is provided to the customer to place orders (Example: 1829-W15). A CMV is a special bid offering. Therefore, it is NOT generally announced.

- The MTM portion of the machine label is the 4-digit MT and 3-digit model, where model = "CTO" (Example: 1829-CTO). The PRODUCT ID portion of the machine label is the 4-digit MT and 3-digit CMV model (Example: 1829-W15).
- The PEW record is the 4-digit MT and 3-digit model, where model = "CTO" (Example: 1829-CTO).
- eSupport will show both the CTO and CMV machine type models (Example: 1829-CTO and 1829-W15 will be found on the eSupport site.)
- The HMM will have the 4-digit MT and 3-digit CTO model only (Example: 1829-CTO). Again, CMVs are custom models and are not found in the HMM.

General Announce Variant (GAV)

This is a standard model (fixed configuration). GAVs are announced and offered to all customers. The MTM portion of the machine label is a 4-digit MT and 3-digit model, where model = a "fixed part number", not "CTO" (Example: 1829-F1U). Also, PEW, eSupport, and the HMM will list these products under the same fixed model number.

FRU identification for CTO, CMV, and GAV products

There are three information resources to identify which FRUs are used to support CTO, CMV, and GAV products. These sources are PEW, eSupport, and the HMM.

Using PEW

- PEW is the primary source for identifying FRU part numbers and FRU descriptions for the key commodities for CTO, CMV and GAV products at a MT - serial number level. An example of key commodities are hard disk drives, system boards, microprocessors, Liquid Crystal Displays (LCDs), and memory.
- Remember, all CTO and CMV products are loaded in PEW under the 4-digit MT and 3-digit model, where model = "CTO" (Example: 1829-CTO). GAVs are loaded in PEW under the 4-digit MT and 3-digit model, where model = a "fixed part number", not "CTO" (Example: 1829-F1U).
- PEW can be accessed at the following Web site: <http://w3-01.ibm.com/pc/entitle/pg2/Service.wss/display/Home>
Customers can also access PEW via <http://www-307.ibm.com/pc/support/site.wss/product.do?template=/warranty/>

warranty.vm&sitestyle=lenovo

Select Warranty lookup. Input the MT and the Serial number and the list of key commodities will be returned in the PEW record under COMPONENT INFORMATION.

- **Business Partners** using Eclaim will access PEW when performing Entitlement Lookup. Business Partners will enter Loc ID, MT and Serial, and the key commodities will be returned in the Eclaim record under SYSTEM DETAILS.
- Authorized IBM Business Partners can access Eclaim at the following Web site: <https://wca.eclaim.com>

Using eSupport

For Key Commodities (Examples - hard disk drive, system board, microprocessor, LCD, and memory)

- eSupport can be used to view the list of key commodities built in a particular machine serial (this is the same record found in PEW).
- eSupport can be accessed at the following Web site: <http://www.lenovo.com/support>
- To view the key commodities, click on PARTS INFORMATION, then PARTS LOOKUP. Type in the model type and serial number. The key commodities will be returned in the eSupport record under PARTS SHIPPED WITH YOUR SYSTEM.

For the Remaining FRUs (the complete list of FRUs at the MT Model level)

- eSupport can be used to view the complete list of FRUs for a machine type and model.
- To view the complete list of FRUs, type in the machine type and model (Example: 1829-CTO) under QUICK PATH. Under "View by Document Type" select PARTS INFORMATION. Under "Filter by Category" select SERVICE PARTS. Under "Parts Information by Date" select SYSTEM SERVICE PARTS. The list of service parts by description, with applicable machine type model and FRU will be displayed.

Using the HMM

For Key Commodities (Examples - hard disk drive, system board, microprocessor, LCD, and memory)

Use the HMM as a back-up to PEW and eSupport to view the complete list of FRUs at the MT Model level.

Important information about replacing RoHS compliant FRUs

RoHS, The Restriction of Hazardous Substances in Electrical and Electronic Equipment Directive (2002/95/EC) is a European Union legal requirement affecting the global electronics industry. RoHS requirements must be implemented on Lenovo products placed on the market after June 2006. Products on the market before June 2006 are not required to have RoHS compliant parts. If the original FRU parts are non compliant, replacement parts can also be non compliant. In all cases if the original FRU parts are RoHS compliant, the replacement part must also be RoHS compliant.

Note: RoHS and non-RoHS FRU part numbers with the same fit and function are identified with unique FRU part numbers.

Lenovo plans to transition to RoHS compliance well before the implementation date and expects its suppliers to be ready to support Lenovo's requirements and schedule in the EU. Products sold in 2005 and 2006, will contain some RoHS compliant FRUs. The following statement pertains to these products and any product Lenovo produces containing RoHS compliant FRUs.

RoHS compliant FRUs have unique FRU part numbers. Before or after the RoHS implementation date, failed RoHS compliant parts must always be replaced using RoHS compliant FRUs, so only the FRUs identified as compliant in the system HMM or direct substitutions for those FRUs may be used.

Products marketed before June 2006		Products marketed after June 2006	
Current or original part	Replacement FRU	Current or original part	Replacement FRU
Non-RoHS	Can be Non-RoHS	Must be RoHS	Must be RoHS
Non-RoHS	Can be RoHS		
Non-RoHS	Can sub to RoHS		
RoHS	Must be RoHS		

Note: A direct substitution is a part with a different FRU part number that is automatically shipped by the distribution center at the time of the order.

General checkout

This chapter presents following information:

- “What to do first” on page 24
- “Checkout guide” on page 25
 - “Diagnostics using PC-Doctor for DOS” on page 26
 - “PC-Doctor for Windows” on page 28
- “Power system checkout” on page 29

The descriptions in this chapter apply to any Lenovo 3000 model that supports the PC-Doctor® for DOS diagnostics program. Some descriptions might not apply to your particular computer.

Before you go to the checkout guide, be sure to read the following important notes.

Important notes:

- **Only certified trained personnel should service the computer.**
- **Before replacing any FRU, read the entire page on removing and replacing FRUs.**
- **When you replace FRUs, use new nylon-coated screws.**
- **Be extremely careful during such write operations as copying, saving, or formatting.** Drives in the computer that you are servicing sequence might have been altered. If you select an incorrect drive, data or programs might be overwritten.
- **Replace a FRU only with another FRU of the correct model.** When you replace a FRU, make sure that the model of the machine and the FRU part number are correct by referring to the FRU parts list.
- **A FRU should not be replaced because of a single, unreproducible failure.** Single failures can occur for a variety of reasons that have nothing to do with a hardware defect, such as cosmic radiation, electrostatic discharge, or software errors. Consider replacing a FRU only when a problem recurs. If you suspect that a FRU is defective, clear the error log and run the test again. If the error does not recur, do not replace the FRU.
- **Be careful not to replace a nondefective FRU.**

What to do first

When you do return a FRU, you must include the following information in the parts exchange form or parts return form that you attach to it:

- ___ 1. Name and phone number of servicer
- ___ 2. Date of service
- ___ 3. Date on which the machine failed
- ___ 4. Date of purchase
- ___ 5. Failure symptoms, error codes appearing on the display, and beep symptoms
- ___ 6. Procedure index and page number in which the failing FRU was detected
- ___ 7. Failing FRU name and part number
- ___ 8. Machine type, model number, and serial number
- ___ 9. Customer's name and address

Note for warranty: During the warranty period, the customer may be responsible for repair costs if the computer damage was caused by misuse, accident, modification, unsuitable physical or operating environment, or improper maintenance by the customer.

Following is a list of some common items that are not covered under warranty and some symptoms that might indicate that the system was subjected to stress beyond normal use.

Before checking problems with the computer, determine whether the damage is covered under the warranty by referring to the following list:

The following are not covered under warranty:

- LCD panel cracked from the application of excessive force or from being dropped
- Scratched (cosmetic) parts
- Distortion, deformation, or discoloration of the cosmetic parts
- Plastic parts, latches, pins, or connectors that have been cracked or broken by excessive force
- Damage caused by liquid spilled into the system
- Damage caused by the improper insertion of a PC Card or the installation of an incompatible card
- Improper disc insertion or use of an optical drive
- Diskette drive damage caused by pressure on the diskette drive cover, foreign material in the drive, or the insertion of a diskette with multiple labels
- Damaged or bent diskette eject button
- Fuses blown by attachment of a nonsupported device
- Forgotten computer password (making the computer unusable)
- Sticky keys caused by spilling a liquid onto the keyboard
- Use of an incorrect ac adapter on laptop products

The following symptoms might indicate damage caused by nonwarranted activities:

- Missing parts might be a symptom of unauthorized service or modification.
- If the spindle of a hard disk drive becomes noisy, it may have been subjected to excessive force, or dropped.

Checkout guide

Use the following procedures as a guide in identifying and correcting problems with the Lenovo 3000 computer.

Note: The diagnostic tests are intended to test only Lenovo 3000 products. The use of non-Lenovo 3000 products, prototype cards, or modified options can lead to false indications of errors and invalid system responses.

1. Identify the failing symptoms in as much detail as possible.
2. Verify the symptoms. Try to re-create the failure by running the diagnostic test or by repeating the operation.

Diagnostics using PC-Doctor for DOS

The Lenovo 3000 computer has a test program called PC-Doctor for DOS (hereafter called *PC-Doctor*.) You can detect errors by running the diagnostics test included in PC-Doctor. This section is an overview of the procedure. For details that depend on model-unique functions, refer to “Lenovo 3000 N500” on page 43.

For some possible configurations of the computer, PC-Doctor might not run correctly. To avoid this problem, you need to initialize the computer setup by use of the BIOS Setup Utility before you run PC-Doctor. On the BIOS Setup Utility screen, press F9, Enter, F10, and then Enter.

Note: When you initialize the computer configuration, some devices are disabled, such as the serial port. If you test one of these devices, you will need to enable it by using Configuration utility for DOS. The utility is available on the following Web site: <http://www.lenovo.com/support>

Creating the PC-Doctor diagnostics diskette

To create the PC-Doctor disk from the Rescue and Recovery[®] workspace, do as follows:

1. Enter the Rescue and Recovery workspace by pressing the Lenovo CareSM button during POST.
2. When the Rescue and Recovery workspace finishes loading, click **Diagnostic Diskette**.
3. Authenticating the digital signature takes about 15 seconds; then the Lenovo 3000 computer will reboot into PC-DOS.
4. A batch file automatically starts up to prompt you through the process of creating diskettes. You are notified of how many diskettes you will need.
 - a. You are prompted to insert each diskette in sequence.
 - b. Typically, all you need to do is to press the Enter key for the floppy drive; the system then formats and creates the diskette.
 - c. Each diskette is erased and formatted with the PC-Doctor for DOS boot image.
5. Once all the diskettes have been created, the Lenovo 3000 computer will reboot. The user is asked to remove all diskettes from the drive, or to insert the first diskette created if it is desired to run the diagnostics.

Testing the computer

To run the test, do as follows:

1. Insert the PC-Doctor disk into the diskette drive; then power on the computer.

If the computer cannot be powered on, go to “Power system checkout” on page 29, and check the power sources.

If an error code appears, go to “Symptom-to-FRU index” on page 36.

On the first screen, select the model and press Enter. Follow the instructions on the screen.
2. The main panel of PC-Doctor appears.
3. Select **Diagnostics** with the arrow keys, and press Enter.

A pull-down menu appears. (Its exact form depends on the model.)

Note: PC-Doctor menu does not mean the formal support device list. Some unsupported device names may appear in the PC-Doctor menu.

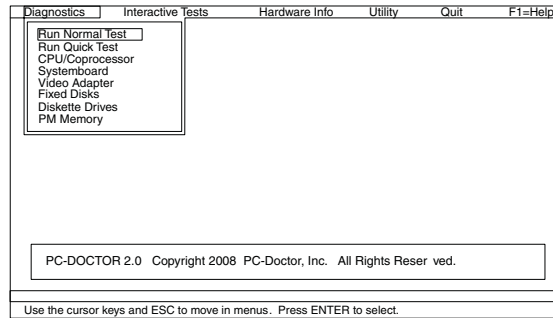

The options on the test menu are as follows:

Diagnostics	Interactive Tests
<ul style="list-style-type: none"> • Run Normal Test • Run Quick Test • CPU/Coprocessor • Systemboard • Video Adapter • Fixed Disks • Diskette Drives • PM Memory 	<ul style="list-style-type: none"> • Keyboard • Video • Mouse • System Load
<p>Notes:</p> <ul style="list-style-type: none"> • In the Keyboard test in Interactive Tests, the Fn key should be held down with M key for at least 2 seconds; otherwise, it cannot be sensed. • Video Adapter test supports only the LCD display on the Lenovo 3000 computer. If you have an external monitor attached to your computer, detach it before running PC-Doctor for DOS. 	

4. Run the applicable function test.
5. Follow the instructions on the screen. If there is a problem, PC-Doctor shows messages describing it.
6. To exit the test, select **Quit — Exit Diag.**
To cancel the test, press Esc.

Note: After running PC-Doctor, check the time and date on the system and reset them if they are incorrect.

Detecting system information with PC-Doctor

PC-Doctor can detect the following system information:

Hardware Info

- System Configuration
- Memory Contents
- Physical Disk Drives
- Logical Disk Drives
- VGA Information
- IDE Drive Info
- PCI Information
- PNPISA Info

- SMBIOS Info
- VESA LCD Info
- Hardware Events Log

Utility

- Run External Tests
- Surface Scan Hard Disk
- Benchmark System
- DOS Shell
- Tech Support Form
- Battery Rundown
- View Test Log
- Print Log
- Save Log
- Full Erase Hard Drive
- Quick Erase Hard Drive

PC-Doctor for Windows

This product is designed to help you troubleshoot and resolve problems related to your computer. Select one of the categories listed below to display symptoms and solutions:

- Check System Health
- System and Device Tests
- Lenovo Troubleshooting Center
- System Reports
- Updates and Support

Power system checkout

To verify a symptom, do the following:

1. Turn off the computer.
2. Remove the battery pack.
3. Connect the ac adapter.
4. Check that power is supplied when you turn on the computer.
5. Turn off the computer.
6. Disconnect the ac adapter and install the charged battery pack.
7. Check that the battery pack supplies power when you turn on the computer.

If you suspect a power problem, see the appropriate one of the following power supply checkouts:

- "Checking the AC adapter"
- "Checking operational charging"
- "Checking the battery pack" on page 30

Checking the AC adapter

You are here because the computer fails only when the AC adapter is used.

- If the power-on indicator does not turn on, check the power cord of the AC adapter for correct continuity and installation.
- If the computer does not charge during operation, go to "Checking operational charging"

To check the AC adapter, do the following:

1. Unplug the AC adapter cable from the computer.
2. Measure the output voltage at the plug of the AC adapter cable. See the following figure:

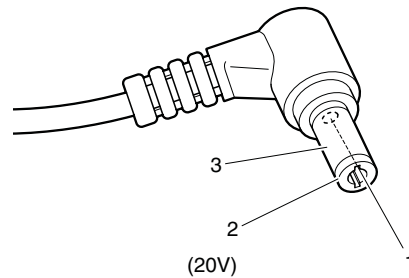

Pin	Voltage (V dc)
1	+19
2	0
3	Ground

Note: Output voltage of pin no.2 of the AC adapter may differ from the one you are servicing.

3. If the voltage is not correct, replace the AC adapter.
4. If the voltage is acceptable, do the following:
 - Replace the system board.
 - If the problem persists, go to "Lenovo 3000 N500" on page 43.

Note: Noise from the AC adapter does not always indicate a defect.

Checking operational charging

To check whether the battery charges properly during operation, use a discharged battery pack or a battery pack that has less than 50% of the total power remaining when installed in the computer.

Perform operational charging. If the battery status indicator or icon does not turn on, remove the battery pack and let it return to room temperature. Reinstall the battery pack. If the charge indicator or icon still does not turn on, replace the battery pack.

If the charge indicator still does not turn on, replace the system board. Then reinstall the battery pack. If it is still not charged, go to the next section.

Checking the battery pack

Battery charging does not start until the Power Meter shows that less than 95% of the total power remains; under this condition the battery pack can charge to 100% of its capacity. This protects the battery pack from being overcharged or from having a shortened life.

To check your battery, move your cursor to the Power Meter icon in the icon tray of the Windows® taskbar and wait for a moment (but do not click), and the percentage of battery power remaining is displayed. To get detailed information about the battery, double-click the Power Meter icon.

Note: If the battery pack becomes hot, it may not be able to charge. Remove it from the computer and leave it at room temperature for a while. After it cools down, reinstall and recharge it.

To check the battery pack, do the following:

1. Power off the computer.
2. Remove the battery pack and measure the voltage between battery terminals 1 (+) and 7 (-). See the following figure:

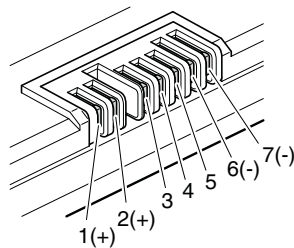

Terminal	Voltage (V dc)
1	+ 0 to + 12.6
7	Ground (-)

3. If the voltage is less than +11.0 V dc, the battery pack has been discharged.

Note: Recharging will take at least 3 hours, even if the indicator does not turn on.

If the voltage is still less than +11.0 V dc after recharging, replace the battery.

4. If the voltage is more than +11.0 V dc, measure the resistance between battery terminals 5 and 7. The resistance must be 4 to 30 K Ω .

If the resistance is not correct, replace the battery pack. If the resistance is correct, replace the system board.

Related service information

This chapter presents following information:

- “Restoring the factory contents by using Product Recovery discs”
- “Passwords” on page 32
- “Power management” on page 34
- “Symptom-to-FRU index” on page 36

Service Web site:

When the latest maintenance diskette and the system program service diskette become available, they will be posted on <http://www.lenovo.com/spm>

Restoring the factory contents by using Product Recovery discs

When the hard disk drive is replaced because of a failure, no Product Recovery program is on the new hard disk. In this case, you must use the recovery disc for the computer. Order the recovery disc and the hard disk drive at the same time so that you can recover the new hard disk drive with the preinstalled software when they arrive. For information on which disc to order, see “Recovery discs” on page 107.

To install the factory contents by using Product Recovery discs, do the following:

Note: The recovery process might take up to 2 hours.

1. Make the optical drive the first start up device in the startup sequence.
2. Insert the bootable **Rescue and Recovery Startup disc** into the optical drive, and then start the computer.
3. In the Rescue and Recovery workspace, complete the following procedure:
 - a. When the Rescue and Recovery workspace opens, click **Continue** on the Welcome window and then click **Restore your system**.
 - b. When a message about accessing a USB device is displayed, click **OK**.
 - c. In the initial window of the “Restore your system” wizard, select **Restore my hard drive to the original factory state** and click **Next**.
 - d. In the next window, select **I do not want to save any files** and click **Next**.
 - e. A warning opens not to turn off the computer during the recovery process. Click **OK**.
4. When the Product Recovery window opens, click **OK**.
5. The Terms and Conditions window opens, select **I accept these terms and conditions** and then click **OK**.
6. After the files necessary for the product recovery are copied from the Rescue and Recovery Startup disc to the hard drive, the system restarts automatically and boot back into Rescue and Recovery. Remove the disc and turn off the computer.
7. Turn on the computer to continue the recovery process.

8. After you restart the computer, the computer prompts you for a supplemental Rescue and Recovery disc. If you have a supplemental Rescue and Recovery disc, click **OK** and insert the supplemental disc. If you do not have a supplemental disc, click **No**.
9. When prompted, insert the appropriate Product Recovery disc and then click **OK**. The second phase of the recovery process begins.
10. When all of the data has been copied from the last Product Recovery disc in the set, a message is displayed prompting you to restart the computer. Remove the disc and then click **YES**, then a message is displayed asking you to continue the recovery process. Click **Continue** to restart your computer, then the computer restarts and the third phase of the recovery process begins.
11. When the recovery process is complete, the Welcome to Microsoft Windows screen is displayed. Follow the instructions on the screen to complete the Windows setup.

Passwords

As many as three passwords may be needed for any Lenovo 3000 computer: the power-on password (POP), the hard-disk password (HDP), and the supervisor password (SVP).

If any of these passwords has been set, a prompt for it appears on the screen whenever the computer is turned on. The computer does not start until the password is entered.

Exception: If only an SVP is installed, the password prompt does not appear when the operating system is booted.

Power-on password

A power-on password (POP) protects the system from being powered on by an unauthorized person. The password must be entered before an operating system can be booted.

Hard-disk password

There are two hard-disk passwords (HDPs):

- User HDP—for the user
- Master HDP—for the system administrator, who can use it to get access to the hard disk even if the user has changed the user HDP

Note: There are two modes for the HDP: **User only** and **Master + User**. The **Master + User** mode requires two HDPs; the system administrator enters both in the same operation. The system administrator then provides the user HDP to the system user.

Attention: If the user HDP has been forgotten, check whether a master HDP has been set. If it has, it can be used for access to the hard disk drive. If no master HDP is available, neither Lenovo nor Lenovo authorized servicers provide any services to reset either the user or the master HDP, or to recover data from the hard disk drive. The hard disk drive can be replaced for a scheduled fee.

Supervisor password

A supervisor password (SVP) protects the system information stored in the BIOS Setup Utility. The user must enter the SVP in order to get access to the BIOS Setup Utility and change the system configuration.

Attention: If the SVP has been forgotten and cannot be made available to the servicer, there is no service procedure to reset the password. The system board must be replaced for a scheduled fee.

How to remove the hard-disk password

Attention: If **User only** mode is selected and the user HDP has been forgotten and cannot be made available to the servicer, neither Lenovo nor Lenovo authorized servicers provide any services to reset the user HDPs or to recover data from the hard disk drive. The hard disk drive can be replaced for a scheduled fee.

To remove a user HDP that has been forgotten, when the SVP and the master HDP are known, do the following:

1. Turn on the computer; then, while the initial screen is displayed, press the Lenovo Care button. The Rescue and Recovery screen opens.
2. Click **Access BIOS**. The System Restart Required window is displayed.
3. Click **Yes**. The computer restarts, and the BIOS Setup Utility screen opens.
4. Select **Security**, using the cursor directional keys to move down the menu.
5. Select **Password**.
6. Select **Hard-disk x password**, where *x* is the letter of the hard disk drive. A pop-up window opens.
7. Select **Master HDP**.
8. Type the current master HDP in the **Enter Current Password** field. then leave the **Enter New Password** field blank, and press Enter twice.
9. Press F10.
10. Select **Yes** in the Setup Configuration window.
Both user HDP and master HDP will have been removed.

Power management

Note: Power management modes are not supported for APM operating system.

To reduce power consumption, the computer has three power management modes: screen blank, sleep (standby), and hibernation.

Screen blank mode

If the time set on the “Turn off monitor” timer in the operating system expires, the LCD backlight turns off.

To put the computer into screen blank mode, press the Lenovo Care button and use the ThinkVantage® Productivity Center.

To end screen blank mode and resume normal operation, press any key.

Sleep (standby) mode

When the computer enters sleep (standby) mode, the following events occur in addition to what occurs in screen blank mode:

- The LCD is powered off.
- The hard disk drive is powered off.
- The CPU stops.

To enter sleep (standby) mode, press Fn+F4.

In certain circumstances, the computer goes into sleep (standby) mode automatically:

- If a “suspend time” has been set on the timer, and the user does not do any operation with the keyboard, the hard disk, the parallel connector, or the diskette drive within that time.
- If the battery indicator blinks orange, indicating that the battery power is low. (Alternatively, if **Hibernate when battery becomes low** has been selected in the “Power Management Properties” window, the computer goes into hibernation mode.)

To cause the computer to return from sleep (standby) mode and resume operation, do one of the following:

- Press the Fn key.
- Open the LCD cover.
- Turn on the power switch.

Also, in the following event, the computer automatically returns from sleep (standby) mode and resumes operation:

- The time set on the resume timer elapses.

Note: The computer does not accept any input immediately after it enters sleep (standby) mode. Wait a few seconds before taking any action to reenter operation mode.

Hibernation mode

In hibernation mode, the following occurs:

- The system status, RAM, VRAM, and setup data are stored on the hard disk.
- The system is powered off.

To cause the computer to enter hibernation mode, do any of the following:

- Press the Fn+F12 keys.
- If you are using the ACPI operating system and have defined one of the following actions as the event that causes the system to go into hibernation mode, perform that action.
 - Closing the lid.
 - Pressing the power button.

Also, the computer goes into hibernation mode automatically in either of the following conditions:

- If a "hibernation time" has been set on the timer, and if the user does not do any operation with the keyboard, the hard disk drive, the parallel connector, or the diskette drive within that time.
- If the timer conditions are satisfied in suspend mode.

When the power is turned on, the computer returns from hibernation mode and resumes operation. The hibernation file in the boot record on the hard disk drive is read, and system status is restored from the hard disk drive.

Symptom-to-FRU index

This section contains following information:

- “Numeric error codes”
- “Error messages” on page 38
- “Beep symptoms” on page 39
- “No-beep symptoms” on page 39
- “LCD-related symptoms” on page 40
- “Intermittent problems” on page 41
- “Undetermined problems” on page 41

The symptom-to-FRU index in this section lists symptoms and errors and their possible causes. The most likely cause is listed first, in boldface type.

Note: Do the FRU replacement or other actions in the sequence shown in the column headed “FRU or action, in sequence.” If replacing a FRU does not solve the problem, put the original part back in the computer. Do not replace a nondefective FRU.

This index can also help you determine, during regular servicing, what FRUs are likely to need to be replaced next.

A numeric error is displayed for each error detected in POST or system operation. In the displays, **n** can be any number.

If no numeric code is displayed, check the narrative descriptions of symptoms. If the symptom is not described there, go to “Intermittent problems” on page 41.

Note:

For a device not supported by diagnostic codes in the Lenovo 3000 computers, see the manual for that device.

Numeric error codes

Table 1. Numeric error codes

Symptom or error	FRU or action, in sequence
0200 Hard disk error—The hard disk is not working.	1. Reseat the hard disk drive. 2. Load Setup Defaults in BIOS Setup Utility. 3. Hard disk drive. 4. System board.
021x Keyboard error.	Run interactive tests of the keyboard and the auxiliary input device.
0220 Monitor type error—Monitor type does not match the one specified in CMOS.	Load Setup Defaults in BIOS Setup Utility.
0230 Shadow RAM error—Shadow RAM fails at offset nnnn.	System board.
0231 System RAM error—System RAM fails at offset nnnn.	1. DIMM. 2. System board.

Table 1. Numeric error codes (continued)

Symptom or error	FRU or action, in sequence
0232 Extended RAM error— Extended RAM fails at offset nnnn.	<ol style="list-style-type: none"> 1. DIMM. 2. System board.
0250 System battery error—System battery is dead.	<ol style="list-style-type: none"> 1. Charge the backup battery for more than 8 hours by connecting the ac adapter. 2. Replace the backup battery and run BIOS Setup Utility to reset the time and date.
0251 System CMOS checksum bad— Default configuration used.	<ol style="list-style-type: none"> 1. Charge the backup battery for more than 8 hours by connecting the ac adapter. 2. Replace the backup battery and run BIOS Setup Utility to reset the time and date.
0260 System timer error.	<ol style="list-style-type: none"> 1. Charge the backup battery for more than 8 hours by connecting the ac adapter. 2. Replace the backup battery and run BIOS Setup Utility to reset the time and date. 3. System board.
0270 Real-time clock error.	<ol style="list-style-type: none"> 1. Charge the backup battery for more than 8 hours by connecting the ac adapter. 2. Replace the backup battery and run BIOS Setup Utility to reset the time and date. 3. System board.
0280 Previous boot incomplete— Default configuration used.	<ol style="list-style-type: none"> 1. Load “Setup Default” in BIOS Setup Utility. 2. DIMM. 3. System board.
02F4 EISA CMOS not writable.	<ol style="list-style-type: none"> 1. Load Setup Defaults in BIOS Setup Utility. 2. Replace the backup battery. 3. System board.
02F5 DMA test failed.	<ol style="list-style-type: none"> 1. DIMM. 2. System board.
02F6 Software NMI failed	<ol style="list-style-type: none"> 1. DIMM. 2. System board.
02F7 Fail-safe timer NMI failed	<ol style="list-style-type: none"> 1. DIMM. 2. System board.

Error messages

Table 2. Error messages

Symptom or error	FRU or action, in sequence
Unsupported memory.	DIMM. Make sure to use supported memory.
Device address conflict.	<ol style="list-style-type: none"> 1. Load "Setup Defaults" in the BIOS Setup Utility. 2. Backup battery. 3. System board.
Allocation error for device.	<ol style="list-style-type: none"> 1. Load "Setup Defaults" in the BIOS Setup Utility. 2. Backup battery. 3. System board.
Failing bits: nnnn.	<ol style="list-style-type: none"> 1. DIMM. 2. System board.
Invalid system configuration data.	<ol style="list-style-type: none"> 1. DIMM. 2. System board.
I/O device IRQ conflict.	<ol style="list-style-type: none"> 1. Load "Setup Defaults" in the BIOS Setup Utility. 2. Backup battery. 3. System board.
Hibernation error.	<ol style="list-style-type: none"> 1. Restore the system configuration to what it was before the computer entered hibernation mode. 2. If memory size has been changed, re-create the hibernation file.
Fan error.	<ol style="list-style-type: none"> 1. Fan. 2. Thermal grease. 3. System board.
Thermal sensing error.	System board.
Authentication of system services failed. Press <Esc> to resume.	The Predesktop Area in the HDD is corrupted. Restore it from a recovery disc.
Cannot boot from any device.	<p>Check the status of device which you want to boot from.</p> <p>Device not found.</p> <ol style="list-style-type: none"> 1. The device you want to boot from. 2. System board. <p>Device Error.</p> <ol style="list-style-type: none"> 1. The device you want to boot from. 2. System board. <p>No valid operating system.</p> <ol style="list-style-type: none"> 1. Check that the operating system has no failure and is installed correctly. 2. Reinstall the operation system. <p>Excluded from boot order.</p> <ul style="list-style-type: none"> • Enter the BIOS Setup Utility and add the device in boot order.

Beep symptoms

Table 3. Beep symptoms

Symptom or error	FRU or action, in sequence
One beep and a blank, unreadable, or flashing LCD.	<ol style="list-style-type: none"> 1. Reseat the LCD connector. 2. LCD assembly. 3. External CRT. 4. System board.
One long and two short beeps, and a blank or unreadable LCD.	<ol style="list-style-type: none"> 1. System board. 2. LCD assembly. 3. DIMM.
Two short beeps with error codes.	POST error. See “Numeric error codes” on page 36.
Two short beeps and a blank screen.	<ol style="list-style-type: none"> 1. System board. 2. DIMM.
Three short beeps, pause, three more short beeps, and one short beep.	<ol style="list-style-type: none"> 1. DIMM. 2. System board
One short beep, pause, three short beeps, pause, three more short beeps, and one short beep.	
Only the cursor appears.	Reinstall the operating system.
Four cycles of four short beeps and a blank screen.	System board (security chip)
Five short beeps and a blank screen.	System board

No-beep symptoms

Table 4. No-beep symptoms

Symptom or error	FRU or action, in sequence
No beep, power-on indicator on, LCD blank, and no POST.	<ol style="list-style-type: none"> 1. Make sure that every connector is connected tightly and correctly. 2. DIMM. 3. System board.
No beep, power-on indicator on, and LCD blank during POST.	<ol style="list-style-type: none"> 1. Reseat DIMM. 2. System board.
The power-on password prompt appears.	A power-on password or a supervisor password is set. Type the password and press Enter .
The hard-disk password prompt appears.	A hard-disk password is set. Type the password and press Enter .

LCD-related symptoms

Important: The TFT LCD for the notebook computer contains many thin-film transistors (TFTs). The presence of a small number of dots that are missing, discolored, or always lighted is characteristic of TFT LCD technology, but excessive pixel problems can cause viewing concerns. The LCD should be replaced if the number of missing, discolored, or lighted dots in any background is as follows:

Table 5. Minimum quantity of defective pixels required for LCD replacement on June 2006 or later manufactured Lenovo 3000

LCD resolution	Bright dots	Dark dots	Bright and dark dots
XGA, WXGA	5	6	6
WXGA+, SXGA+, WSXGA+	5	8	10
UXGA, WUXGA, QXGA	5	13	13

Notes:

- Lenovo will not provide replacement if the LCD is within specification as we cannot guarantee that any replacement LCD will have zero pixel defects.
- A bright dot means a pixel is always on (white or color.)
- A dark dot means a pixel is always off (black color.)
- One pixel consists of R, G, B sub-pixels.

Table 6. LCD-related symptoms

Symptom or error	FRU or action, in sequence
No beep, power-on indicator on, and a blank LCD during POST.	System board.
<ul style="list-style-type: none"> • LCD backlight not working. • LCD too dark. • LCD brightness cannot be adjusted. • LCD contrast cannot be adjusted. 	<ol style="list-style-type: none"> 1. Reseat the LCD connectors. 2. LCD assembly. 3. System board.
<ul style="list-style-type: none"> • LCD screen unreadable. • Characters missing pixels. • Screen abnormal. • Wrong color displayed. 	<ol style="list-style-type: none"> 1. See important note for “LCD-related symptoms.” 2. Reseat all LCD connectors. 3. LCD assembly. 4. System board.
Horizontal or vertical lines displayed on LCD.	LCD assembly.

Intermittent problems

Intermittent system hang problems can be due to a variety of causes that have nothing to do with a hardware defect, such as cosmic radiation, electrostatic discharge, or software errors. FRU replacement should be considered only when a problem recurs.

When analyzing an intermittent problem, do the following:

1. Run the diagnostic test for the system board in loop mode **at least 10 times**.
2. If no error is detected, do **not** replace any FRUs.
3. If any error is detected, replace the FRU shown by the FRU code. Rerun the test to verify that no more errors exist.

Undetermined problems

If the diagnostic tests did not identify the adapter or device that has failed, if wrong devices are installed, or if the system simply is not operating, follow these procedures to isolate the failing FRU (do not isolate FRUs that have no defects).

Verify that all attached devices are supported by the computer.

Verify that the power supply being used at the time of the failure is operating correctly. (See "Power system checkout" on page 29.)

1. Turn off the computer.
2. Visually check each FRU for damage. Replace any damaged FRU.
3. Remove or disconnect all of the following devices:
 - a. Non-Lenovo 3000 devices
 - b. Devices attached to the docking station or the port replicator
 - c. Printer, mouse, and other external devices
 - d. Battery pack
 - e. Hard disk drive
 - f. External diskette drive or optical drive
 - g. DIMM
 - h. Optical disk or diskette in the internal drive
 - i. PC Cards
4. Turn on the computer.
5. Determine whether the problem has been solved.
6. If the problem does not recur, reconnect the removed devices one at a time until you find the failing FRU.
7. If the problem remains, replace the following FRUs one at a time (do not replace a nondefective FRU):
 - a. System board
 - b. LCD assembly

Lenovo 3000 N500

This chapter presents following product-specific service references and product-specific parts information.

- “Specifications”
- “Status indicators” on page 45
- “FRU tests” on page 47
- “Fn key combinations” on page 48
- “FRU replacement notices” on page 49
- “Removing and replacing a FRU” on page 53
- “Locations” on page 93
- “Parts list” on page 96

Specifications

The following table lists the specifications of the Lenovo 3000 N500 :

Table 7. Specifications

Feature	Description
Processor	<ul style="list-style-type: none">• Intel® Celeron M processor 575 (2.0 GHz), 1-MB L2 cache• Intel Celeron M processor 585 (2.16 GHz), 1-MB L2 cache• Intel Pentium dual-core processor T3200 (2.0 GHz), 1-MB L2 cache• Intel Pentium dual-core processor T3400 (2.16 GHz), 1-MB L2 cache• Intel® Core™ 2 Duo processor P7350 (2.0 GHz), 3-MB L2 cache• Intel Core 2 Duo processor PP8400 (2.26 GHz), 3-MB L2 cache• Intel Core 2 Duo processor P8600 (2.4 GHz), 3-MB L2 cache• Intel Core 2 Duo processor P9500 (2.53 GHz), 6-MB L2 cache• Intel Core 2 Duo processor T5670 (1.8 GHz), 2-MB L2 cache• Intel Core 2 Duo processor T5800 (2.0 GHz), 2-MB L2 cache• Intel Core 2 Duo processor T5900 (2.2 GHz), 2-MB L2 cache• Intel Core 2 Duo processor T9400 (2.53 GHz), 6-MB L2 cache• Intel Core 2 Duo processor T9600 (2.80 GHz), 6-MB L2 cache
Bus architecture	<ul style="list-style-type: none">• 800-MHz PSB• 667-MHz DDR2 SDRAM (PC2-5300)• PCI bus• PCI Express bus• DMI
Graphic memory chip	<ul style="list-style-type: none">• Intel GMA 4500 Integrated Graphics• Intel GMA X4500 Integrated Graphics• nVidia GeForce 9300 256 MB
Display	<ul style="list-style-type: none">• 15.4-inch, 16M colors, WXGA (1280 × 800 resolution) TFT color LCD

Table 7. Specifications (continued)

Feature	Description
Standard memory	<ul style="list-style-type: none"> • 1-GB DDR2-667 SDRAM SO-DIMM (PC2-5300) card × 1 • 2-GB DDR2-667 SDRAM SO-DIMM (PC2-5300) card × 1
Optional memory	<ul style="list-style-type: none"> • 1-GB DDR2-667 SDRAM SO-DIMM (PC2-5300) card × 1 • 2-GB DDR2-667 SDRAM SO-DIMM (PC2-5300) card × 1 (maximum of 4.0 GB)
CMOS RAM	<ul style="list-style-type: none"> • 242 bytes
Hard disk drive	<ul style="list-style-type: none"> • 160 GB, 5400 rpm, 9.5 mm high, SATA interface • 250 GB, 5400 rpm, 9.5 mm high, SATA interface • 320 GB, 5400 rpm, 9.5 mm high, SATA interface <p>Supported hard disk drives depend on the model.</p>
Optical drive	<ul style="list-style-type: none"> • DVD/CD-RW combo drive, 12.7 mm high • DVD multi drive, 12.7 mm high
I/O port	<ul style="list-style-type: none"> • External monitor connector • Stereo headphone jack • Monaural microphone jack • Docking connector • RJ11 connector • RJ45 connector • Universal serial bus (USB) connector × 4 (compatible with USB 1.1 and 2.0) • 4-in-1 media card reader
Internal modem	<ul style="list-style-type: none"> • 56.6 Kbps
Audio	<ul style="list-style-type: none"> • Built-in stereo speakers • Software control volume
Ethernet (on the system board)	<ul style="list-style-type: none"> • 10/100M Ethernet
PCI Express Mini Card	<ul style="list-style-type: none"> • Lenovo 802.11b/g Wireless LAN Mini-PCI Express Adapter • Intel WiFi Link 5100
ExpressCard slot	<ul style="list-style-type: none"> • One ExpressCard slot and one PC Card (Type-II) slot • One Smart Card slot and one PC Card (Type-II) slot
Bluetooth wireless (some models)	<ul style="list-style-type: none"> • Lenovo 3000 Bluetooth with Enhanced Data Rate (BDC-2.1)
Modem	<ul style="list-style-type: none"> • Lenovo 3000 Modem (MDC-1.5, 56 kbps HDA)
Touch pad	Yes
Integrated camera	Some models
Battery	<ul style="list-style-type: none"> • Li-ion battery (6 cells) 2.4 Ah • Li-ion battery (6 cells) 2.6 Ah
AC adapter	<ul style="list-style-type: none"> • 65-watt type • 90-watt type
Preinstalled operating system	<ul style="list-style-type: none"> • Windows Vista® Home Basic (32 bit) • Windows Vista Home Premium (32 bit) • Windows Vista Business (32 bit)

Status indicators

The system status indicators show the status of the computer, as follows:

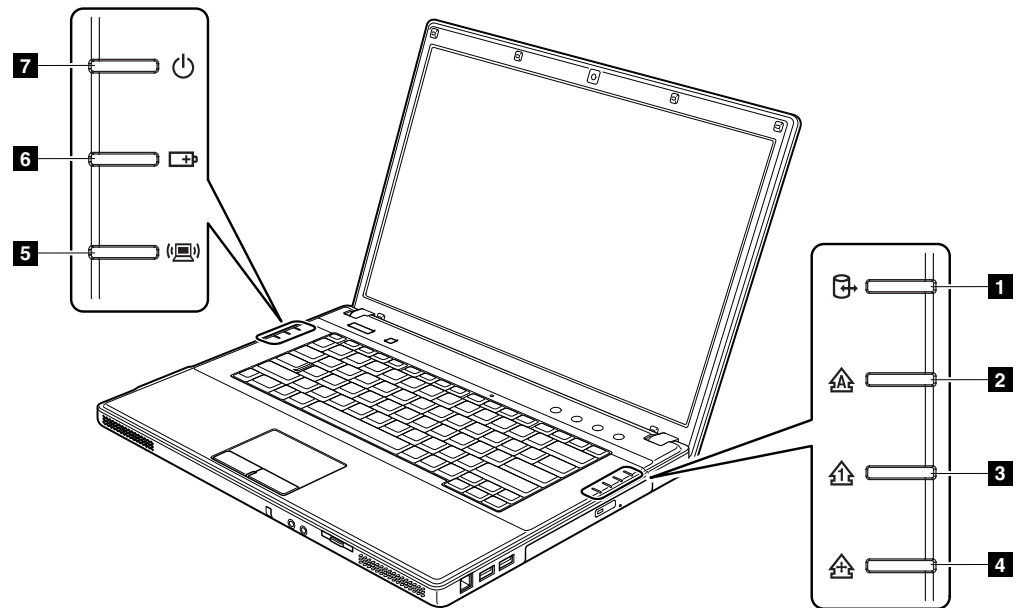

Table 8. Status indicators







Indicator	Meaning
1 Drive in use 	Blue: Data is being read from or written to the hard disk drive, the solid state drive, or the optical disk drive. When this indicator is on, do not put the computer into standby mode or turn off the computer. Note: Do not move the system while the green drive-in-use light is on. Sudden physical shock could cause drive errors.
2 Caps lock 	Blue: Caps Lock mode is enabled. To enable or disable Caps Lock mode, press the Caps Lock key.
3 Num lock 	Blue: The numeric keypad on the keyboard is enabled. To enable or disable the keypad, press and hold the Shift key, and press the NumLk key.
4 Scroll lock 	Blue: Scroll Lock mode is enabled. To enable or disable Scroll Lock mode, press and hold the Shift key, and press the ScrLk key.
5 Wireless status 	Purple: The wireless LAN and the <i>Bluetooth</i> features are on, and the radio link is ready for use. Orange: The <i>Bluetooth</i> feature is on, and the radio link is ready for use. Blue: The wireless LAN feature is on, and the radio link is ready for use. Blinking blue: The wireless LAN feature is on, and the networks are being scanned.

Table 8. Status indicators (continued)

Indicator	Meaning
<p>6 Battery status</p> 	<p>Blue: The battery is charged to 95% or more of its capacity.</p> <p>Blinking blue: The battery is being trickle-charged.</p> <p>Orange: The battery is being normally charged.</p> <p>Off: The computer is operating on battery power, and the battery has enough power.</p> <p>Blinking orange: The computer is operating on battery power, and the battery is charged to no more than 8% of capacity.</p>
<p>7 Power on</p> 	<p>Blue: The computer is on and ready to use. This indicator stays on whenever the computer is on and is not in standby mode.</p>

FRU tests

The following table shows the test for each FRU.

Table 9. FRU tests

FRU	Applicable test
System board	<ol style="list-style-type: none">1. Diagnostics --> CPU/Coprocessor2. Diagnostics --> Systemboard
LCD unit	<ol style="list-style-type: none">1. Diagnostics --> Video Adapter2. Interactive Tests --> Video
Keyboard	<ol style="list-style-type: none">1. Diagnostics --> Systemboard --> Keyboard2. Interactive Tests --> Keyboard
Hard disk drive	Diagnostics --> Fixed Disks
Diskette drive	Diagnostics --> Diskette Drives
Memory	<ol style="list-style-type: none">1. If two DIMMs are installed, remove one of them and run Diagnostics --> PM Memory.2. If the problem does not recur, return the DIMM to its place, remove the other one, and run the test again.3. If the test does not detect the error, run Diagnostics --> PM Memory.

Fn key combinations

The following table shows the function of each combination of Fn with a function key.

Table 10. Fn key combinations

Key combination	Description
Fn+F1	Volume down.
Fn+F2	Volume up.
Fn+F3	Reserved.
Fn+F4	Reserved.
Fn+F5	Enable or disable the built-in wireless networking features and the <i>Bluetooth</i> features. If you press Fn+F5, a list of wireless features is displayed. You can quickly change the power state of each feature in the list.
Fn+F6	Reserved.
Fn+F7	Open the window for Choose Presentation or Display scheme. If you press this combination of keys, a list of schemes is displayed in the window. You can quickly select a scheme in the list.
Fn+F8	Reserved.
Fn+F9	Reserved.
Fn+F10	Make the computer display less bright.
Fn+F11	Make the computer display brighter.
Fn+F12	Put the computer into hibernation mode. To return to normal operation, press the power button.
Fn+Esc	Mute the sound from the computer.
Fn+Insert	Scroll Lock (ScrLk).
Fn+Delete	Numeric Lock (NmLk).
Fn+PrtSc	Has the same function as the SysRq key.
Fn+Pause	Has the same function as the Break key.
Fn+PgUp	Has the same function as the Home key.
Fn+PgDn	Has the same function as the End key.
Fn+cursor keys	These key combinations work with Windows Media Player. Fn+down arrow key works for the Play or Pause button, Fn+up arrow key for the Stop button, Fn+right arrow key for the Next Track button, and Fn+left arrow key for the Previous Track button.

FRU replacement notices

This section contains notices related to removing and replacing parts. Read this section carefully before replacing any FRU.

Screw notices

Loose screws can cause a reliability problem. In the Lenovo 3000 computer, this problem is addressed with special nylon-coated screws that have the following characteristics:

- They maintain tight connections.
- They do not easily come loose, even with shock or vibration.
- They are harder to tighten.
- Each one should be used only once.

Do the following when you service this machine:

- Keep the screw kit (for the P/N, see “Miscellaneous parts” on page 104) in your tool bag.
- Always use new screws.
- Use a torque screwdriver if you have one.

Tighten screws as follows:

- **Plastic to plastic**

Turn an additional **90 degrees** after the screw head touches the surface of the plastic part:

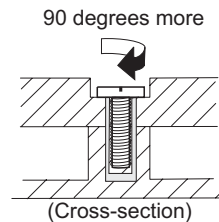

- **Logic card to plastic**

Turn an additional **180 degrees** after the screw head touches the surface of the logic card:

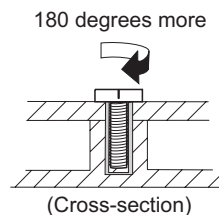

- **Torque driver**

If you have a torque driver, refer to the “Torque” column for each step.

- Make sure that you use the correct screw. If you have a torque screwdriver, tighten all screws firmly to the torque shown in the table. **Never use a screw that you removed. Use a new one. Make sure that all of the screws are tightened firmly.**
- Ensure torque screw drivers are calibrated correctly following country specifications.

Retaining serial numbers

This section includes the following descriptions:

- “Restoring the serial number of the system unit”
- “Retaining the UUID”
- “Reading or writing the ECA information” on page 52

Restoring the serial number of the system unit

When the computer was manufactured, the EEPROM on the system board was loaded with the serial numbers of the system and all major components. These numbers need to remain the same throughout the life of the computer.

If you replace the system board, you must restore the serial number of the system unit to its original value.

Before replacing the system board, save the original serial number by doing the following:

1. Install the CE Utility Diskette for Lenovo 3000 notebooks, and restart the computer.
2. From the main menu, select **1. Set System Identification**.
3. Select **2. Read S/N data from EEPROM**.

The serial number of each device in your computer is displayed; the serial number of the system unit is listed as follows:

- 20: Serial number

Write down that number.

Note: The serial number of the system unit is also written on the label attached to the bottom of the computer.

After you have replaced the system board, restore the serial number by doing the following:

1. Install the CE Utility Diskette for Lenovo 3000 notebooks and restart the computer.
2. From the main menu, select **1. Set System Identification**.
3. Select **1. Add S/N data from EEPROM**.

Follow the instructions on the screen.

If the MTM and Product ID numbers differ from each other on the rear label, use what is shown for the Product ID field. See example below:

MTM on rear label:

TTTT-CTO S/N SSSSSS

Product ID on rear label:

TTTT-MMM (Use this number when setting Serial Number)

In the example, the Serial Number to be input is '1STTTTMMMSSSSSS'.

Retaining the UUID

The Universally Unique Identifier (UUID) is a 128-bit number uniquely assigned to your computer at production and stored in the EEPROM of your system board. The algorithm that generates the number is designed to provide unique IDs until the year A.D. 3400. No two computers in the world have the same number.

When you replace the system board, you must set the UUID on the new system board as follows:

1. Install the CE Utility Diskette for Lenovo 3000 notebooks, and restart the computer.
2. From the main menu, select **4. Assign UUID**.

A new UUID is created and written. If a valid UUID already exists, it is not overwritten.

Reading or writing the ECA information

Information on Engineering Change Announcements (ECA) are stored in the EEPROM of the system board. The electronic storage of this information simplifies the procedure to check if the ECA has been previously applied to a machine. The machine does not need to be disassembled to check for the ECA application.

To check what ECAs have been previously applied to the machine, use the ECA Information Read/Write function on the CE Utility Diskette for Lenovo 3000 notebooks.

1. Insert the CE Utility Diskette for Lenovo 3000 notebooks, and restart the computer.
2. From the main menu, select **6. Set ECA Information**.
3. To read ECA information, select **2. Read ECA/rework number from EEPROM** and follow the instruction.
4. To read box build date, select **5. Read box build date from EEPROM**, and follow the instruction on the screen.

After an ECA has been applied to the machine, the EEPROM must be updated to reflect the ECA's application. Use the CE Utility Diskette for Lenovo 3000 notebooks to update the EEPROM.

Note: Only the ECA number is stored in the EEPROM. The machine type of the ECA is assumed be the same as the machine type of the machine that had the ECA applied to it.

1. Insert the CE Utility Diskette for Lenovo 3000 notebooks, and restart the computer.
2. From the main menu, select **6. Set ECA Information**.
3. To write ECA information, select **1. Write ECA/rework number from EEPROM**, and follow the instruction.
4. To write box build date, select **4. Write box build date from EEPROM**, and follow the instruction on the screen.

If the system board is being replaced, try to read the ECA information from the old system board and transfer the information to the new system. If the system board is inoperable, this will not be possible.

Removing and replacing a FRU

This section presents directions and drawings for use in removing and replacing a FRU. Be sure to observe the following general rules:

1. Do not try to service any computer unless you have been trained and certified. An untrained person runs the risk of damaging parts.
2. Before replacing any FRU, review “FRU replacement notices” on page 49.
3. Begin by removing any FRUs that have to be removed before the failing FRU. Any such FRUs are listed at the top of the page. Remove them in the order in which they are listed.
4. Follow the correct sequence in the steps for removing the FRU, as given in the drawings by the numbers in square callouts.
5. When turning a screw to replace a FRU, turn it in the direction as given by the arrow in the drawing.
6. When removing the FRU, move it in the direction as given by the arrow in the drawing.
7. To put the new FRU in place, reverse the removal procedure and follow any notes that pertain to replacement. For information about connecting and arranging internal cables, see “Locations” on page 93.
8. When replacing a FRU, use the correct screw as shown in the procedures.

 **DANGER**

Before removing any FRU, turn off the computer, unplug all power cords from electrical outlets, remove the battery pack, and then disconnect any interconnecting cables.

Attention: After replacing a FRU, do not turn on the computer until you have made sure that all screws, springs, and other small parts are in place and none are loose inside the computer. Verify this by shaking the computer gently and listening for rattling sounds. Metallic parts or metal flakes can cause electrical short circuits.

Attention: The system board is sensitive to, and can be damaged by, electrostatic discharge. Before touching it, establish personal grounding by touching a ground point with one hand or by using an electrostatic discharge (ESD) strap (P/N 6405959).

1010 Battery pack

⚠ DANGER

Use only the battery specified in the parts list for your computer. Any other battery could ignite or explode.

Table 11. Removal steps of battery pack

Unlock the battery release lever **1**. Holding the battery release lever in the unlocked position **2**, remove the battery pack in the direction shown by arrow **3**.

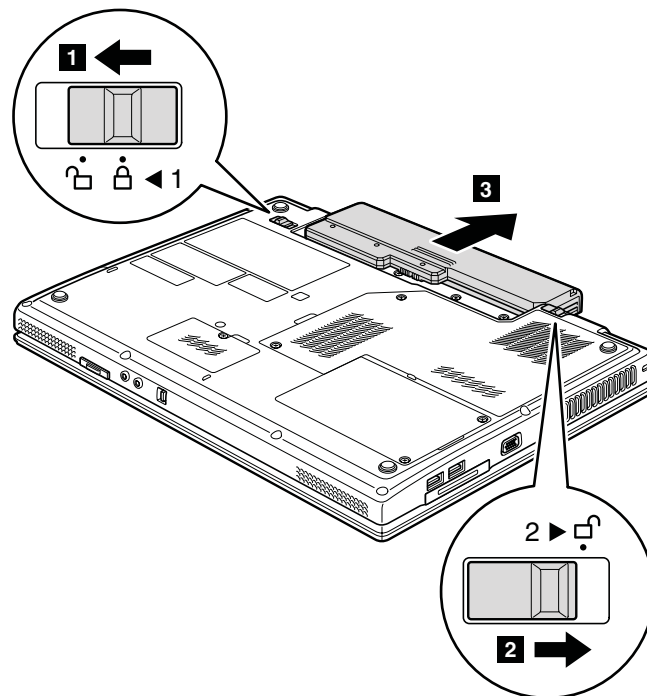

When installing: Install the battery pack along the slide rails of the slot. Then make sure that the battery release lever is in the locked position.

1020 Dummy cards

Table 12. Removal steps of dummy cards

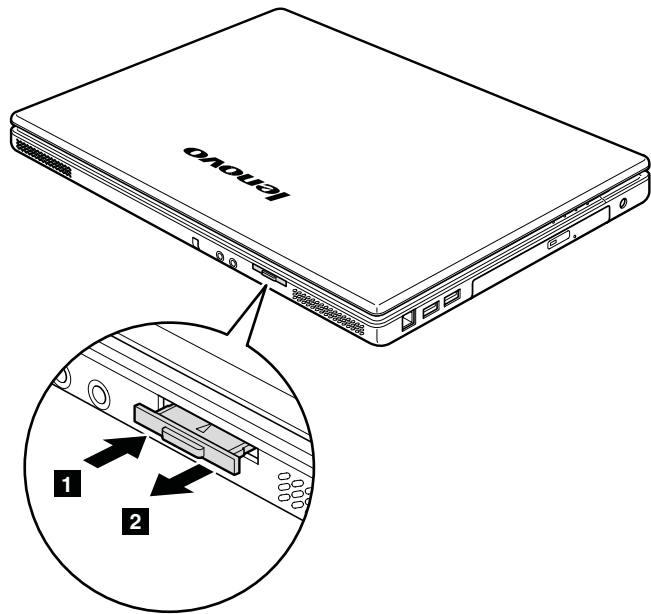
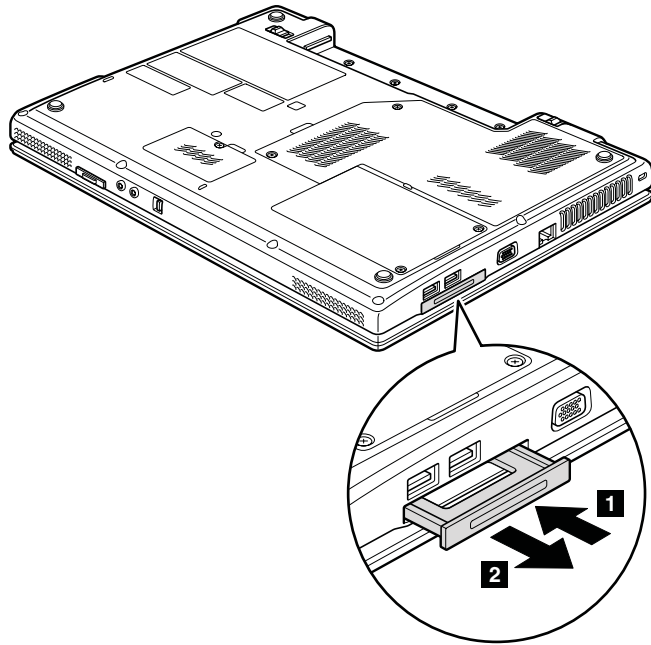

1030 Hard disk drive (HDD) slot cover and HDD

For access, remove this FRU:

- "1010 Battery pack" on page 54

Attention:

- **Do not drop the hard disk drive or apply any physical shock to it.** The hard disk drive is sensitive to physical shock. Improper handling can cause damage and permanent loss of data.
- Before removing the drive, have the user make a backup copy of all the information on it if possible.
- Never remove the drive while the system is operating or is in suspend mode.

Table 13. Removal steps of HDD slot cover and HDD

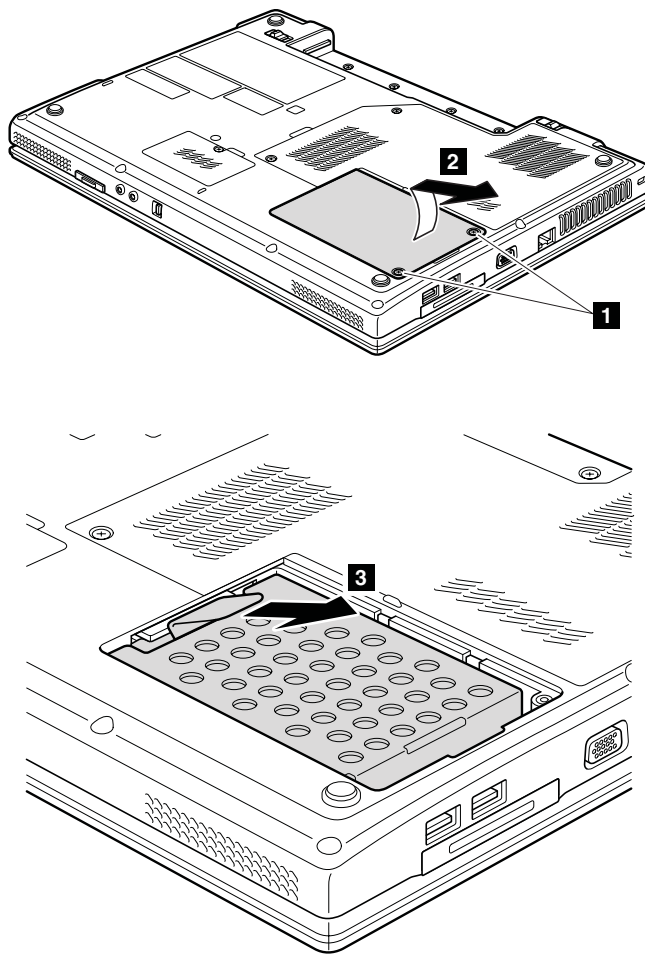

When installing: Make sure that the HDD connector is attached firmly.

Table 13. Removal steps of HDD slot cover and HDD (continued)

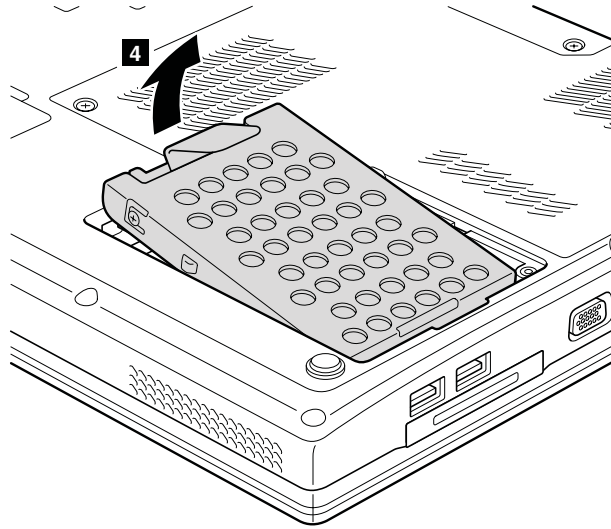

1040 Optical drive

For access, remove this FRU in order:

- “1010 Battery pack” on page 54

Table 14. Removal steps of optical drive

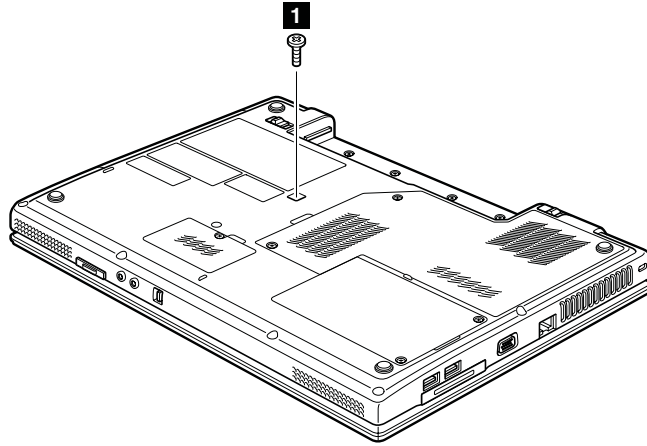

Step	Screw (quantity)	Color	Torque
1	M2.5 × 10 mm, wafer-head, nylon-coated (1)	Black	2.0 Nm (2.5 kgfcm)

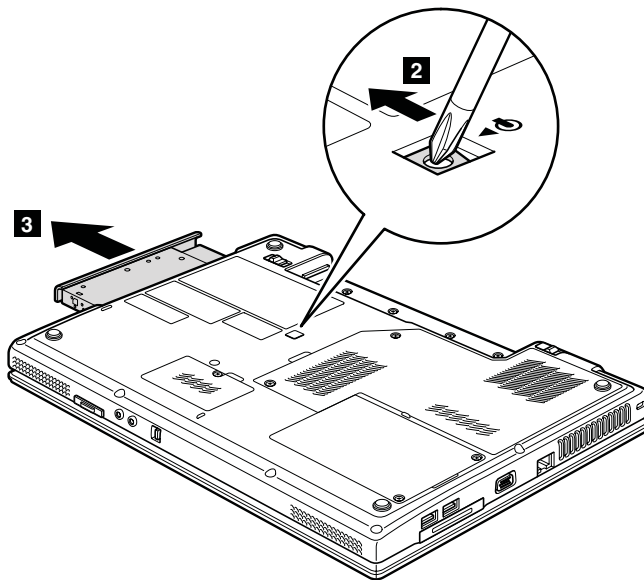

1050 Thermal slot cover

For access, remove this FRU in order:

- “1010 Battery pack” on page 54

Table 15. Removal steps of thermal slot cover

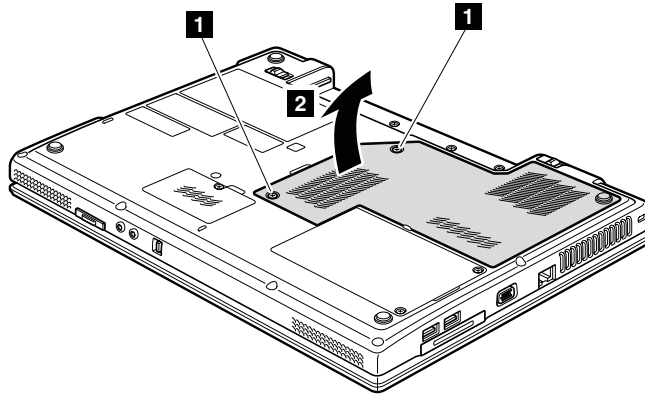

1060 DIMM

For access, remove these FRUs in order:

- “1010 Battery pack” on page 54
- “1050 Thermal slot cover” on page 59

Table 16. Removal steps of DIMM

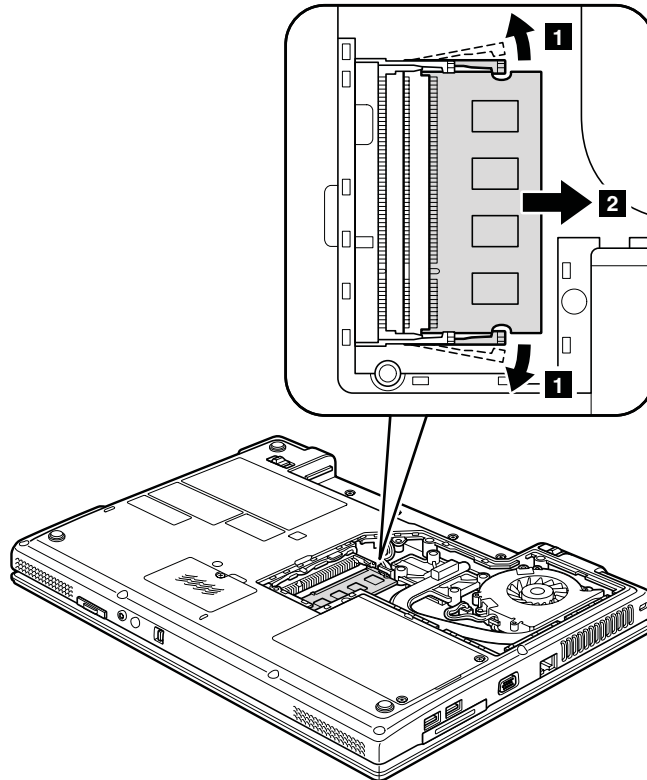

Note: If only one DIMM is used on the computer you are servicing, the card must be installed in SLOT-0 (**a**: lower slot), but not in SLOT-1 (**b**: upper slot).

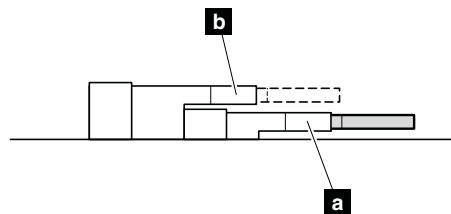

When installing: Insert the notched end of the DIMM into the socket. Press the DIMM firmly, and pivot it until it snaps into the place. Make sure that it is firmly fixed in the slot and does not move easily.

1070 Fan assembly

For access, remove these FRUs in order:

- “1010 Battery pack” on page 54
- “1050 Thermal slot cover” on page 59

Table 17. Removal steps of fan assembly

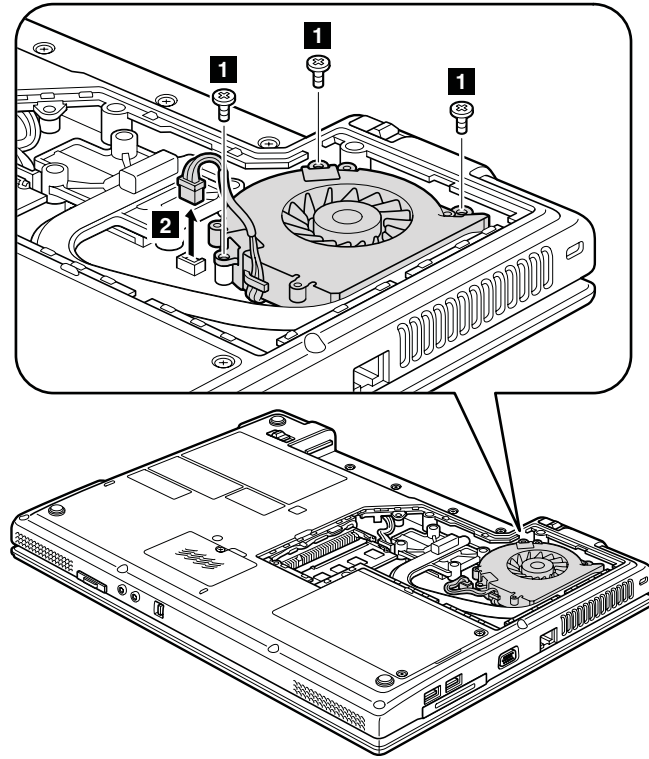

Step	Screw (quantity)	Color	Torque
1	M2.5 × 5 mm, wafer-head, nylon-coated (3)	Silver	2.0 Nm (2.5 kgfcm)

When installing: Make sure that the fan connector is attached firmly to the system board.

Table 17. Removal steps of fan assembly (continued)

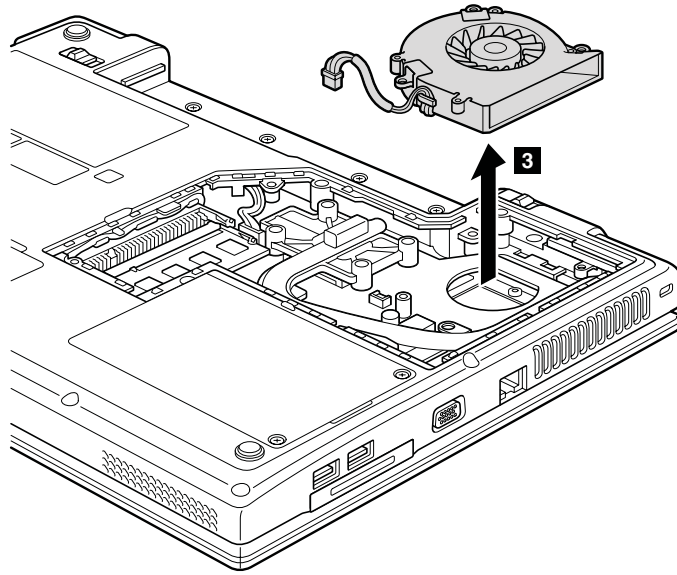

1080 Heat sink assembly

For access, remove these FRUs in order:

- “1010 Battery pack” on page 54
- “1050 Thermal slot cover” on page 59
- “1070 Fan assembly” on page 61

Table 18. Removal steps of heat sink assembly

Note: Step **5** is only for the models with discrete graphics chip. For the models with integrated graphics chip, skip the step **5**.

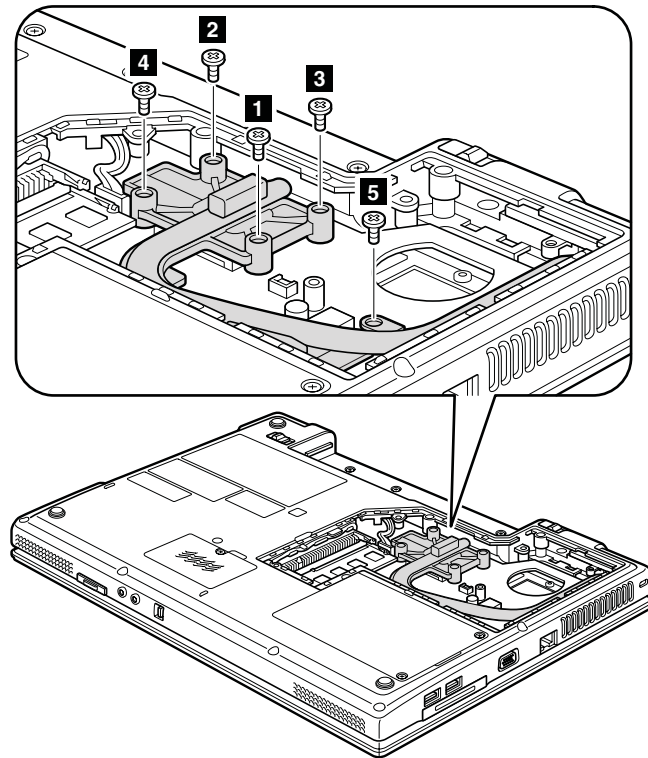

Step	Screw (quantity)	Color	Torque
1 to 4	M2.5 × 5 mm with spring, nylon-coated (4)	Silver	2.0 Nm (2.5 kgfcm)
5	M2.5 × 5 mm, wafer-head, nylon-coated (3)	Silver	2.0 Nm (2.5 kgfcm)

Table 18. Removal steps of heat sink assembly (continued)

Attention: Do not handle the heat sink assembly roughly. Improper handling of the heat sink assembly can cause distortion or deformation and imperfect contact with components.

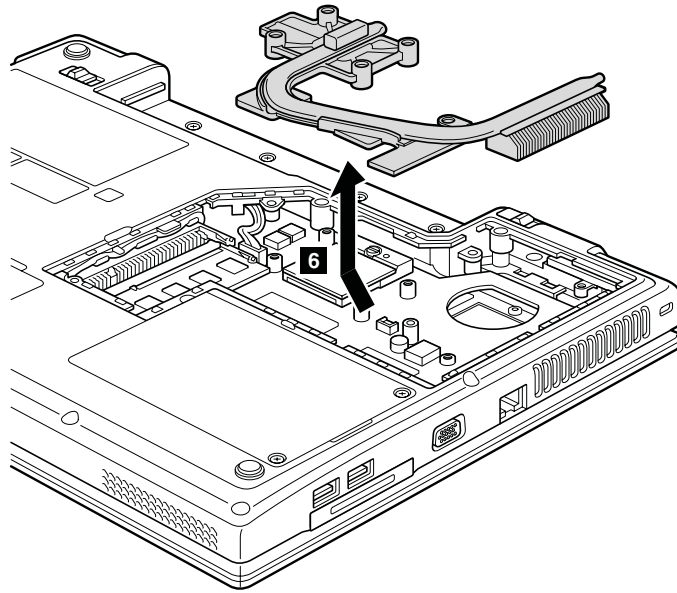

When installing: Before you attach the fan assembly to the computer, apply thermal grease, at an amount of 0.2 grams, on the part marked **a** as in the following figure. Either too much or too less application of grease can cause a thermal problem due to imperfect contact with a component. You also need to peel the thin film off from the rubber **b**. In models with the discrete graphics chip, there is an additional thermal rubber **c** whose film to be peeled off.

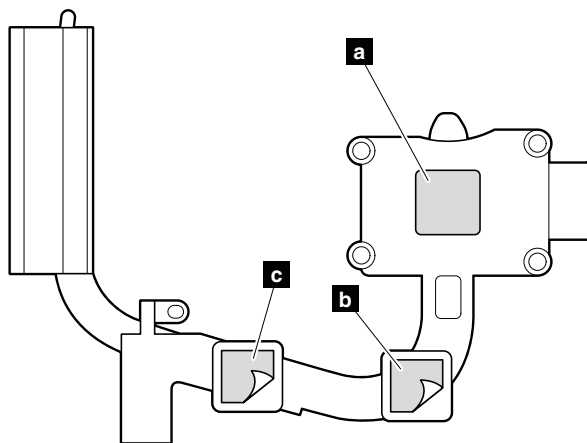

1090 Wireless LAN card slot cover and PCI Express Mini Card for wireless LAN

For access, remove this FRU in order:

- “1010 Battery pack” on page 54

Table 19. Removal steps of Wireless LAN card slot cover and PCI Express Mini Card for wireless LAN

Note: Loosen the screws **1**, but do not remove them.

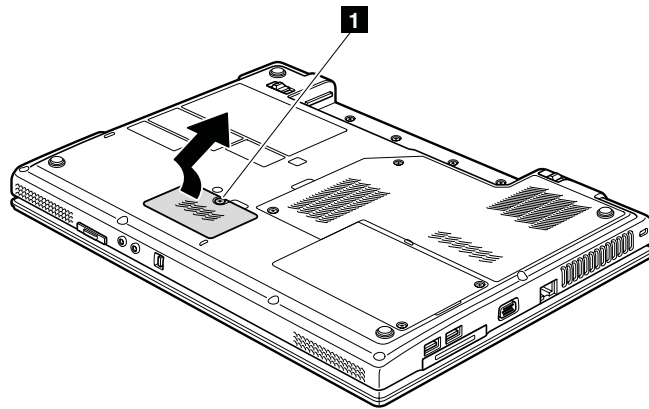

In step **3**, unplug the jacks by using the removal tool antenna RF connector (P/N: 08K7159) or pick the connectors with your fingers and gently unplug them in direction of the arrow.

Note: Some models might have three antenna cables in step **3**.

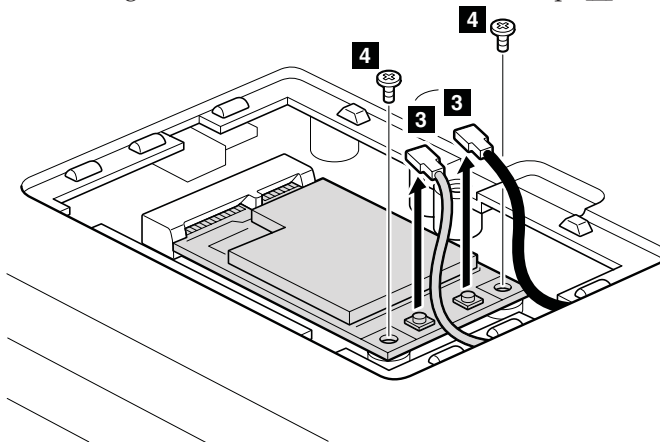

Step	Screw (quantity)	Color	Torque
4	M2 × 3 mm, wafer-head, nylon-coated (2)	Black	1.5 Nm (2.0 kgfcm)

Table 19. Removal steps of Wireless LAN card slot cover and PCI Express Mini Card for wireless LAN (continued)

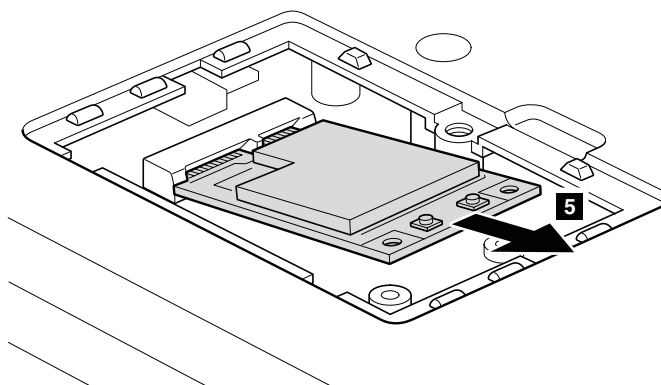

When installing:

- In models with wireless LAN card that has two antenna connectors, plug the gray cable into the jack labeled **MAIN**, and the black cable into the jack labeled **AUX** on the card. If the computer you are servicing has three cables, put the white cable in the cable holder.
- In models with wireless LAN card that has three antenna connectors, plug the gray cable (**MAIN**) into the jack labeled **TR1**, the white cable (3rd) into jack labeled **R0** or **TR3**, and the black cable (**AUX**) into jack labeled **TR2** on the card.

1100 CPU

For access, remove these FRUs in order:

- “1010 Battery pack” on page 54
- “1050 Thermal slot cover” on page 59
- “1070 Fan assembly” on page 61
- “1080 Heat sink assembly” on page 63

Attention: CPU is extremely sensitive. When you service the CPU, avoid any kind of rough handling.

Table 20. Removal steps of CPU

Rotate the head of the screw in the direction shown by arrow **1** to release the lock; then remove the CPU.

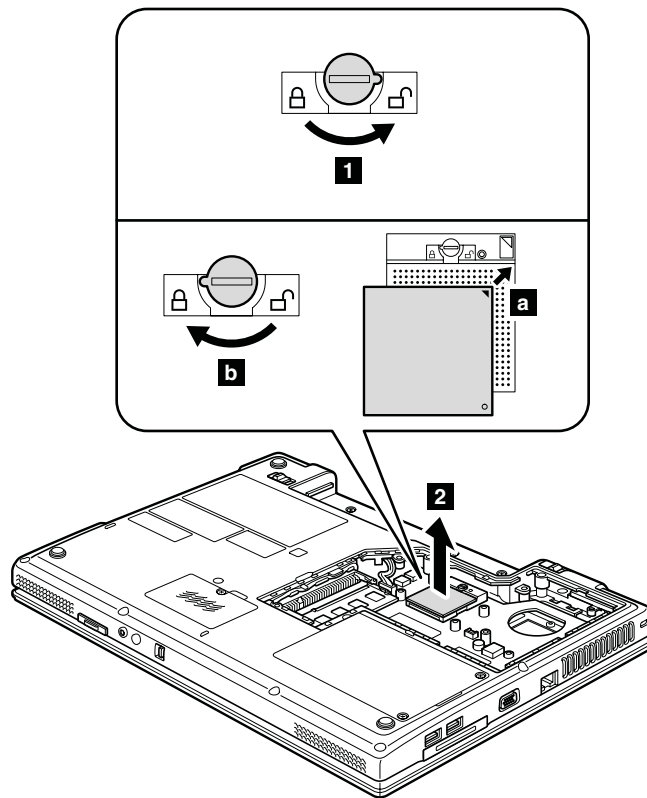

When installing: Place the CPU on the CPU socket **a**, and then rotate the head of the screw in the direction shown by arrow **b** to secure the CPU.

1110 Keyboard cover and power board

For access, remove this FRU in order:

- “1010 Battery pack” on page 54

Note: Power board is attached to the keyboard cover.

Table 21. Removal steps of keyboard cover and power board

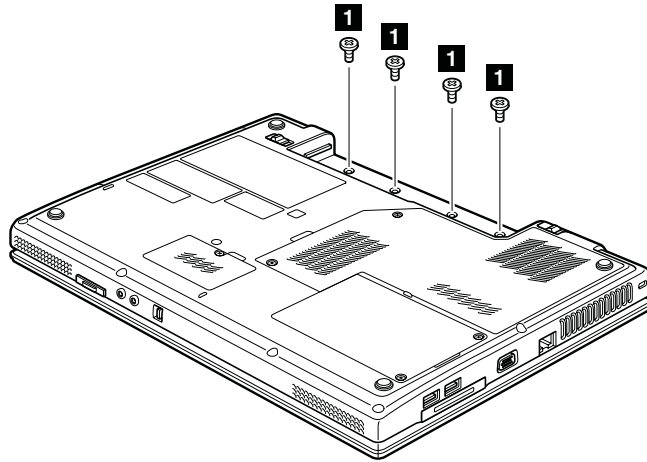

Step	Screw (quantity)	Color	Torque
1	M2 × 2.5 mm, wafer-head, nylon-coated (4)	Black	1.0 Nm (1.5 kgfcm)

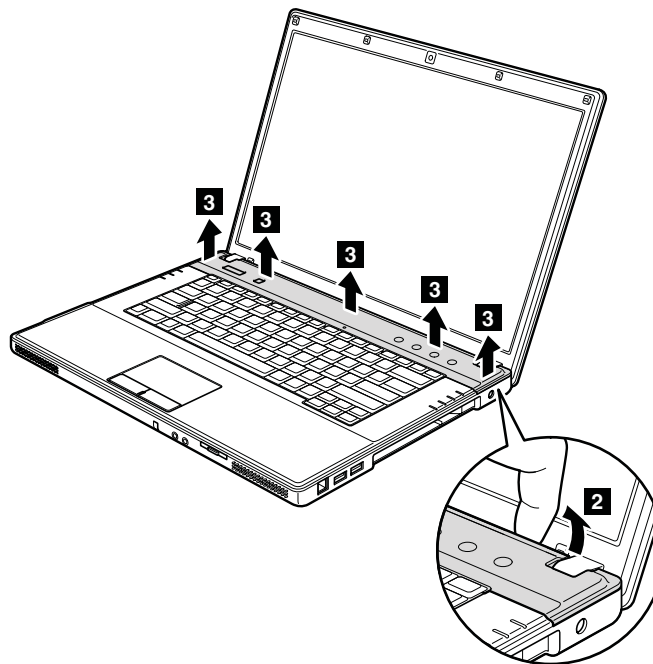
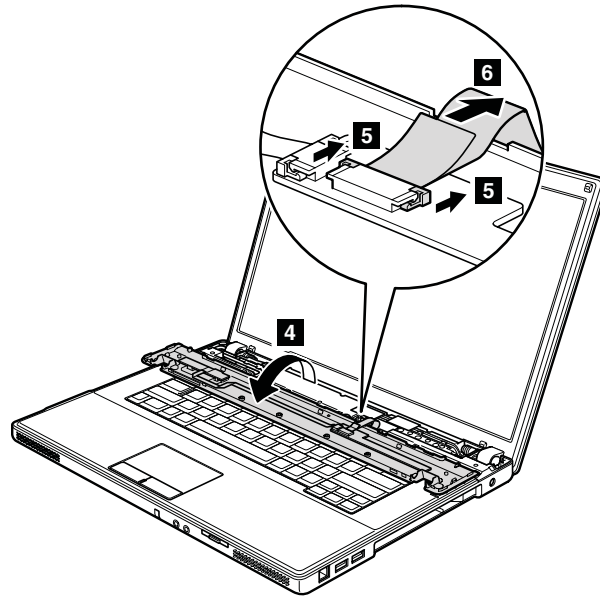
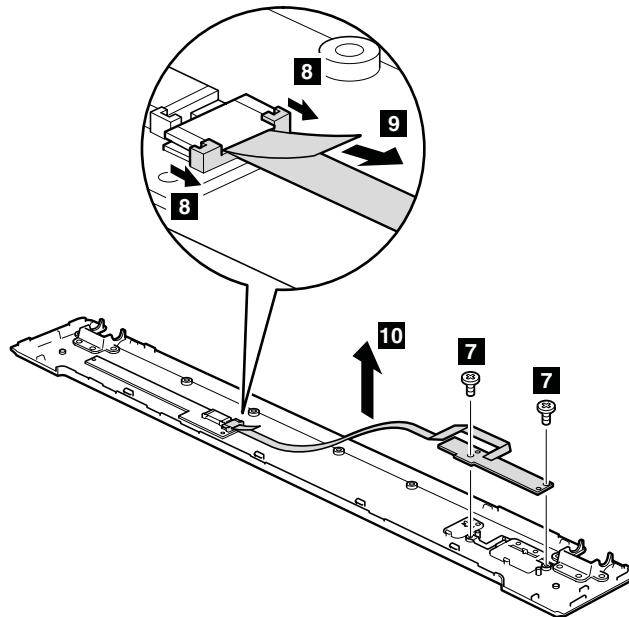

Table 21. Removal steps of keyboard cover and power board (continued)



When installing: Make sure that the FPC connector is attached firmly.



When installing: Make sure that the FPC connector is attached firmly.

Step	Screw (quantity)	Color	Torque
7	M2 × 3 mm, wafer-head, nylon-coated (2)	Silver	1.5 Nm (2.0 kgfcm)

1120 *Bluetooth* daughter card (BDC-2.1)

For access, remove these FRUs in order:

- “1010 Battery pack” on page 54
- “1110 Keyboard cover and power board” on page 68

Table 22. Removal steps of BDC-2.1

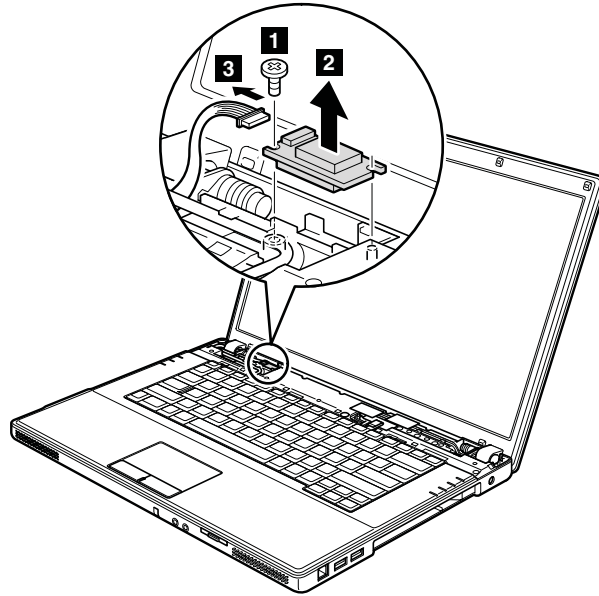

Step	Screw (quantity)	Color	Torque
1	M2 × 3 mm, wafer-head, nylon-coated (1)	Silver	1.0 Nm (1.5 kgfcm)

When installing: Make sure that connector is attached firmly.

1130 Keyboard

For access, remove these FRUs in order:

- “1010 Battery pack” on page 54
- “1110 Keyboard cover and power board” on page 68

Table 23. Removal steps of keyboard

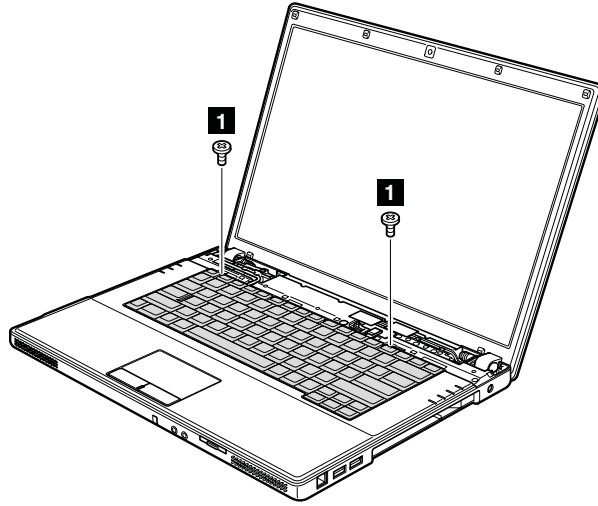

Step	Screw (quantity)	Color	Torque
1	M2 × 2.5 mm, wafer-head, nylon-coated (1)	Black	1.0 Nm (1.5 kgfcm)

Table 23. Removal steps of keyboard (continued)

Lift the keyboard a little in the direction shown by arrow **2**, and then detach the connector **3**.

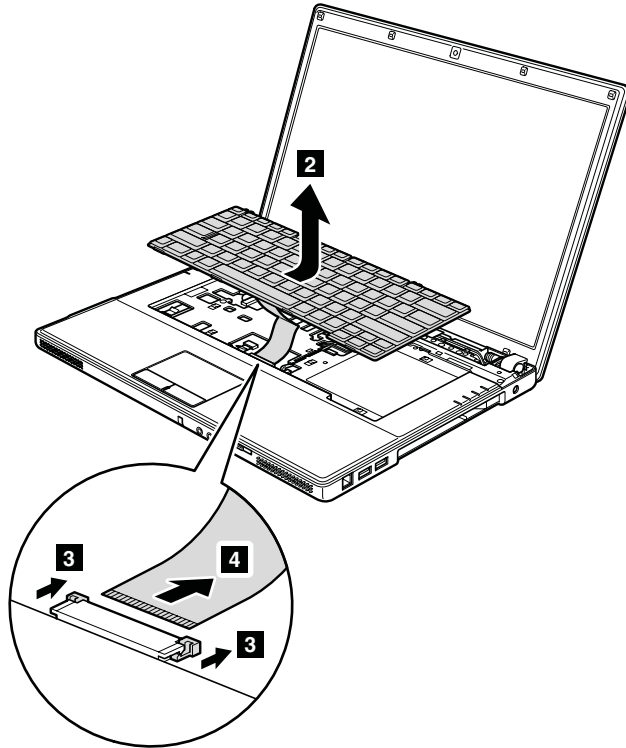

When installing: Make sure that the FPC connector is attached firmly.

1140 LCD unit

For access, remove these FRUs in order:

- “1010 Battery pack” on page 54
- “1090 Wireless LAN card slot cover and PCI Express Mini Card for wireless LAN” on page 65
- “1110 Keyboard cover and power board” on page 68
- “1130 Keyboard” on page 71

Table 24. Removal steps of LCD unit

Release the antenna cables from the cable guides on bottom side of the computer.

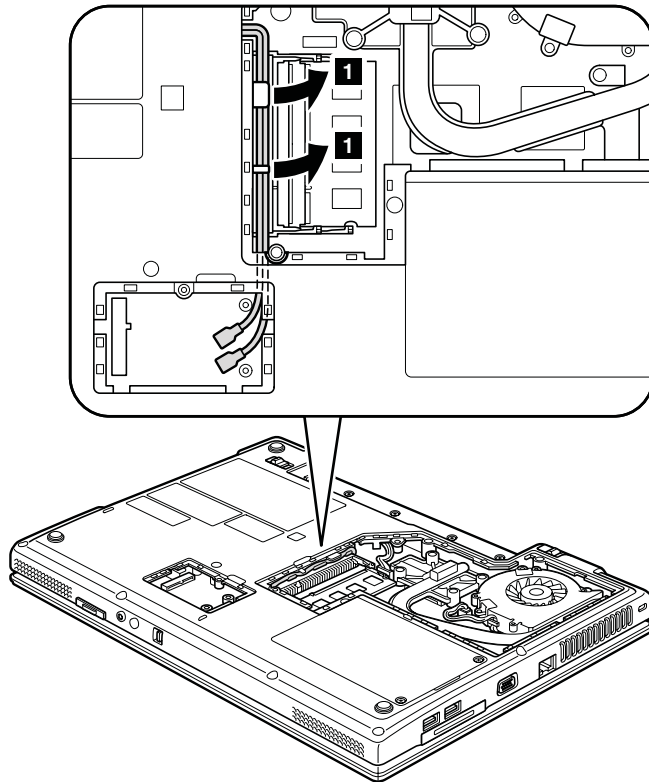
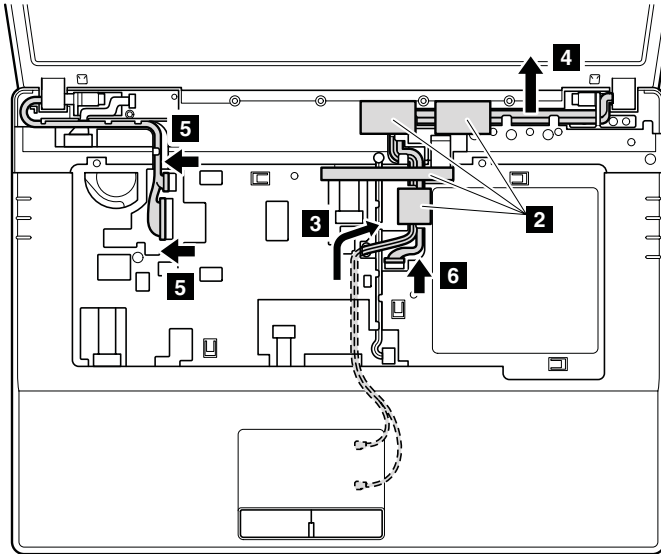

Table 24. Removal steps of LCD unit (continued)

Peel off the tapes securing the antenna cables **2**. Then release the cables from the guide hole of the system board **3** and the cable guides **4**.



When installing:

1. Route the antenna cables along the cable guides and secure them with the tapes. As you route the cables, make sure that they are not subjected to any tension. Tension could cause the cables to be damaged by the cable guides, or a wire to be broken.
2. Make sure that the LCD connector is attached firmly.

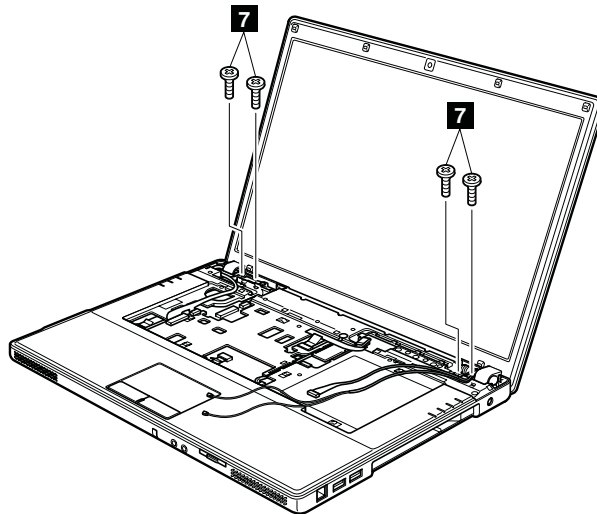

Step	Screw (quantity)	Color	Torque
7	M2.5 × 8 mm, wafer-head, nylon-coated (4)	Black	2.0 Nm (2.5 kgfcm)

Table 24. Removal steps of LCD unit (continued)

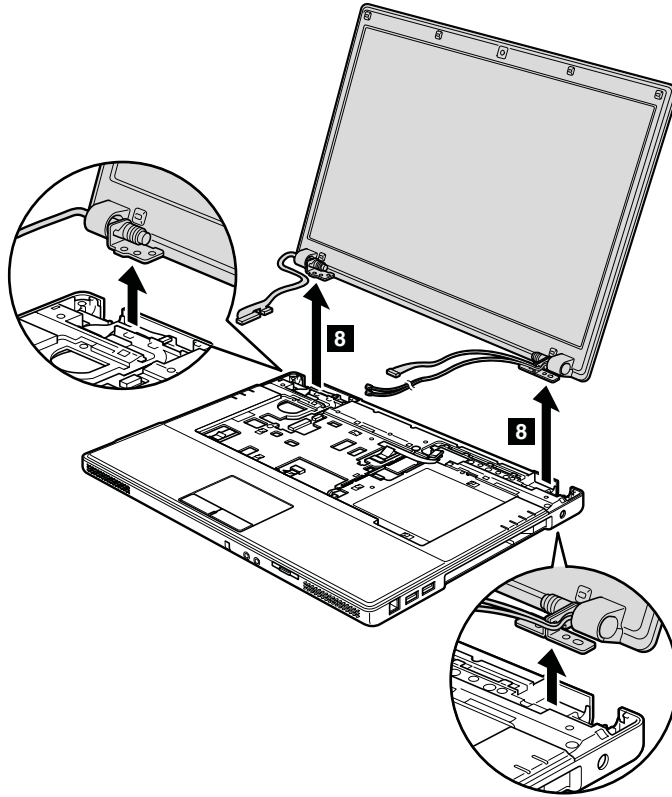

1150 Keyboard bezel and LED board L

For access, remove these FRUs in order:

- “1010 Battery pack” on page 54
- “1090 Wireless LAN card slot cover and PCI Express Mini Card for wireless LAN” on page 65
- “1110 Keyboard cover and power board” on page 68
- “1130 Keyboard” on page 71
- “1140 LCD unit” on page 73

Note: LED board L is attached to the keyboard bezel.

Table 25. Removal steps of keyboard bezel and LED board L

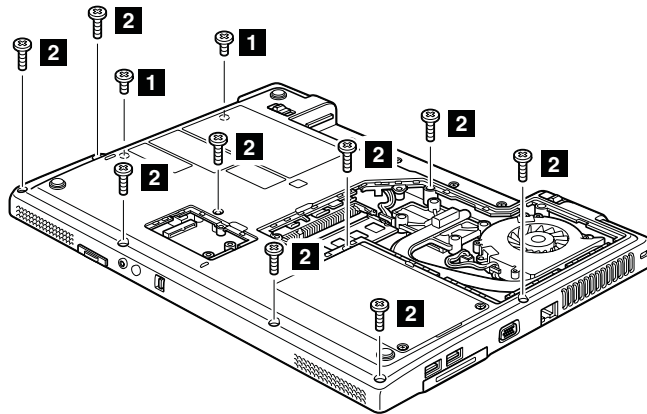

Step	Screw (quantity)	Color	Torque
1	M2 × 2.5 mm, wafer-head, nylon-coated (2)	Black	1.0 Nm (1.5 kgfcm)
2	M2.5 × 8 mm, wafer-head, nylon-coated (9)	Black	2.0 Nm (2.5 kgfcm)

Table 25. Removal steps of keyboard bezel and LED board L (continued)

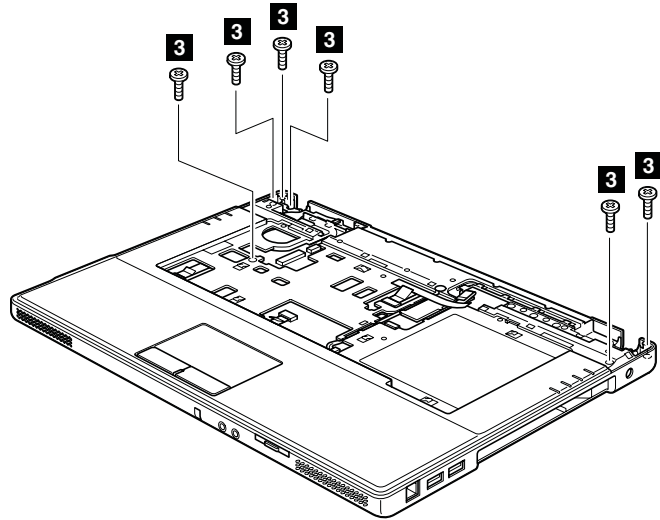

Step	Screw (quantity)	Color	Torque
3	M2.5 × 5 mm, small-head, nylon-coated (6)	Black	2.0 Nm (2.5 kgfcm)

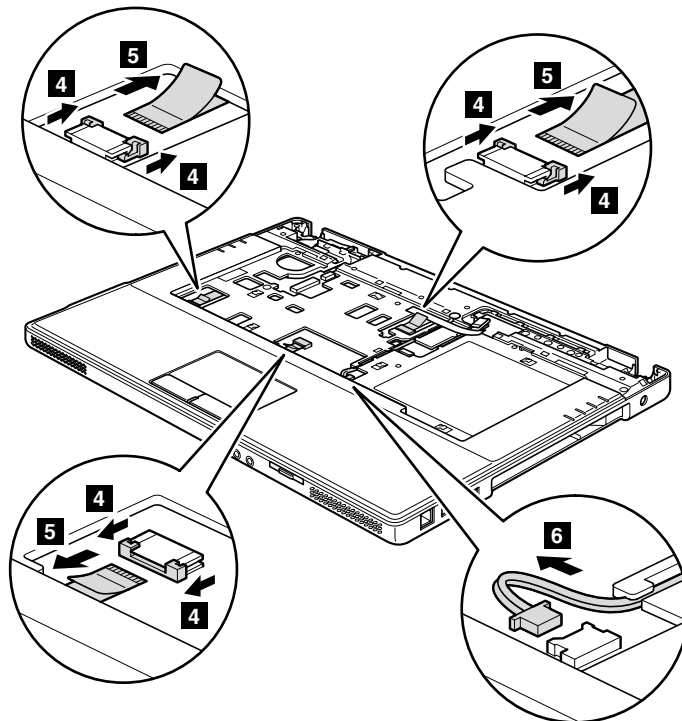

When installing: Make sure that all the FPC connectors and the cable are attached firmly.

Table 25. Removal steps of keyboard bezel and LED board L (continued)

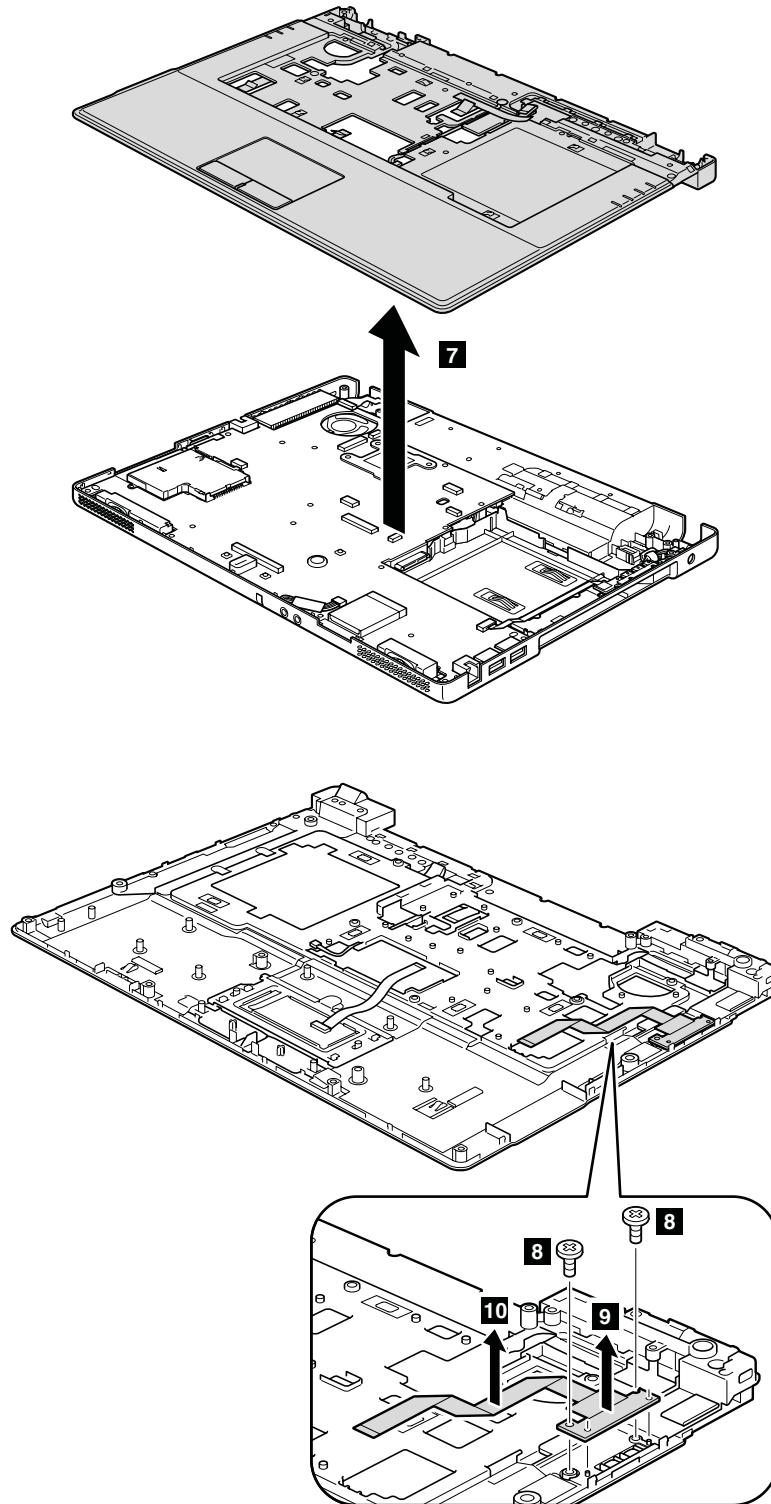

Step	Screw (quantity)	Color	Torque
8	M2 × 3 mm, wafer-head, nylon-coated (2)	Silver	2.0 Nm (2.5 kgfcm)

1160 LED board R

For access, remove these FRUs in order:

- “1010 Battery pack” on page 54
- “1090 Wireless LAN card slot cover and PCI Express Mini Card for wireless LAN” on page 65
- “1110 Keyboard cover and power board” on page 68
- “1130 Keyboard” on page 71
- “1140 LCD unit” on page 73
- “1150 Keyboard bezel and LED board L” on page 76

Table 26. Removal steps of LED board R

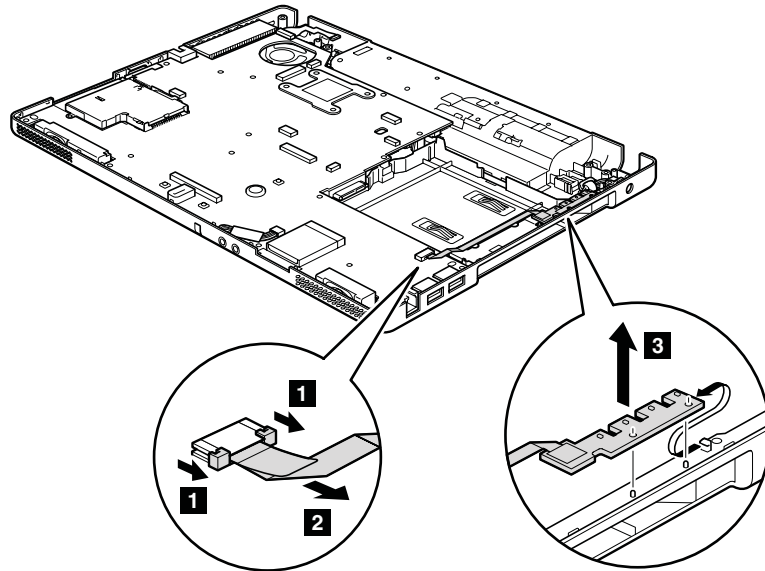

When installing: Make sure that the FPC connector is attached firmly.

1170 System board and ExpressCard slot assembly

Important notices for handling the system board:

When handling the system board, bear the following in mind.

- Be careful not to drop the system board on a bench top that has a hard surface, such as metal, wood, or composite.
- Avoid rough handling of any kind.
- At every point in the process, be sure not to drop or stack the system board.
- If you put a system board down, be sure to put it only on a padded surface such as an ESD mat or conductive corrugated material.

For access, remove these FRUs in order:

- "1010 Battery pack" on page 54
- "1090 Wireless LAN card slot cover and PCI Express Mini Card for wireless LAN" on page 65
- "1110 Keyboard cover and power board" on page 68
- "1130 Keyboard" on page 71
- "1140 LCD unit" on page 73
- "1150 Keyboard bezel and LED board L" on page 76
- "1160 LED board R" on page 79

Note: ExpressCard slot assembly is attached to the system board.

Table 27. Removal steps of system board, PC Card/ExpressCard slots assembly

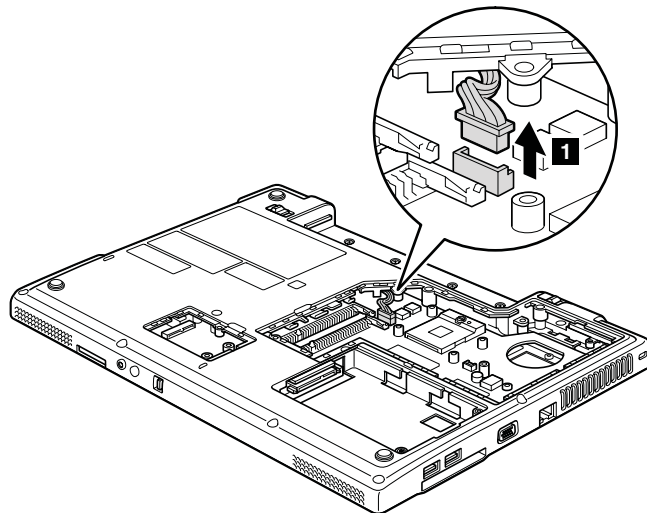

When installing: Make sure that the connector is attached firmly.

Table 27. Removal steps of system board, PC Card/ExpressCard slots assembly (continued)

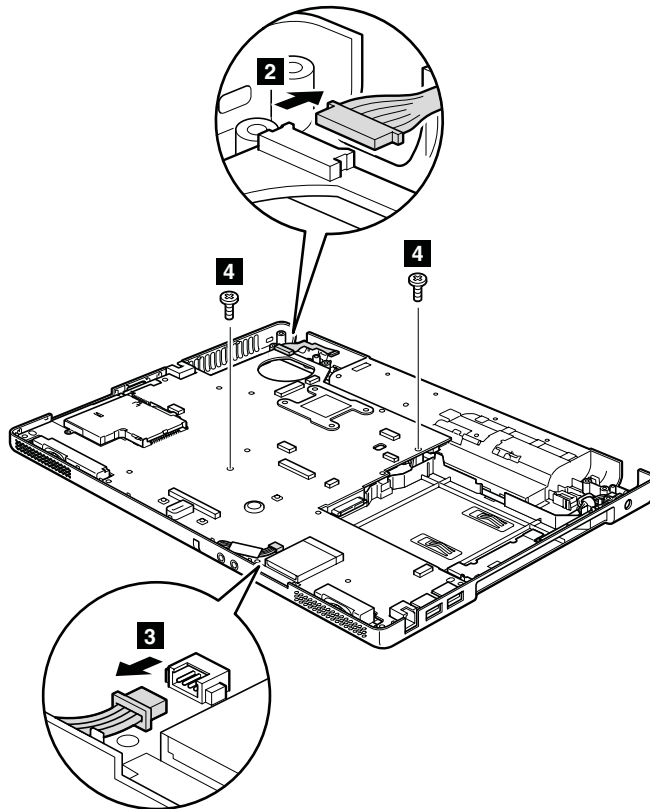

When installing: Make sure that the connectors are attached firmly.

Step	Screw (quantity)	Color	Torque
4	M2.5 × 5 mm, wafer-head, nylon-coated (2)	Black	2.0 Nm (2.5 kgfcm)

Table 27. Removal steps of system board, PC Card/ExpressCard slots assembly (continued)

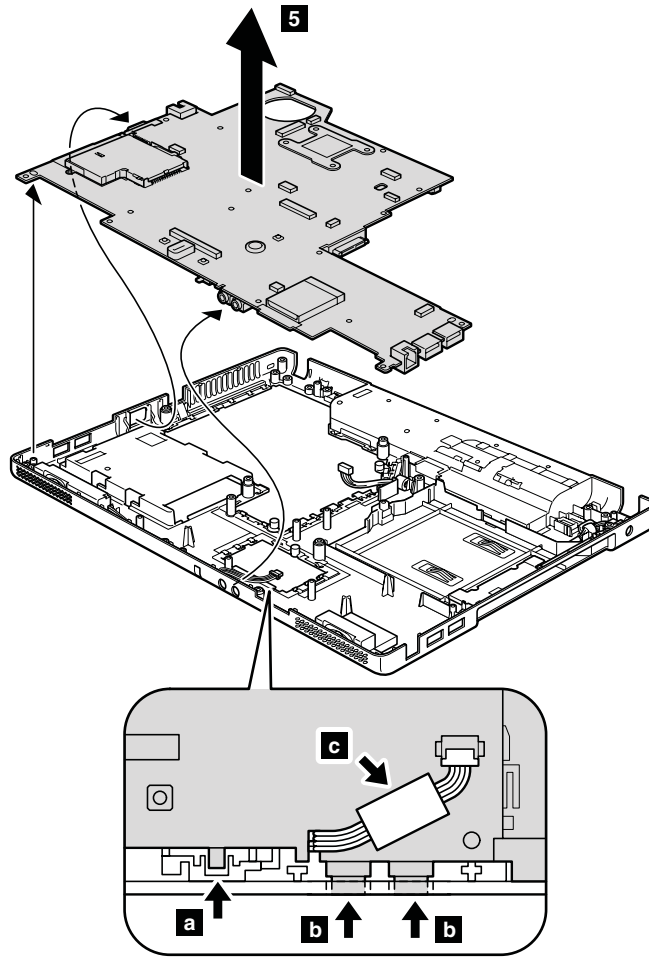

When installing: When attaching the system board to the base cover, adjust the placement of the wireless radio switch as shown in **a**, and make sure that both of the audio jack and the microphone jack are attached to the holes on the base cover as shown in **b**. Improper placement of the switch or those jacks might cause a damage.

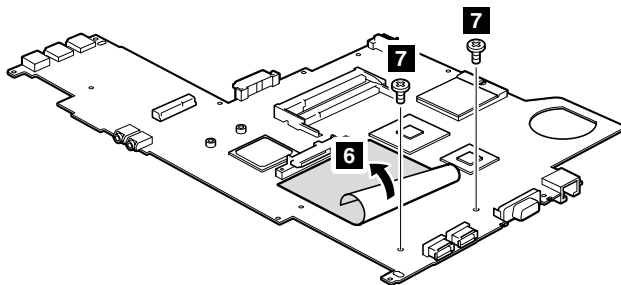

Step	Screw (quantity)	Color	Torque
7	M2 × 3 mm, wafer-head, nylon-coated (2)	Black	2.0 Nm (2.5 kgfcm)

Table 27. Removal steps of system board, PC Card/ExpressCard slots assembly (continued)

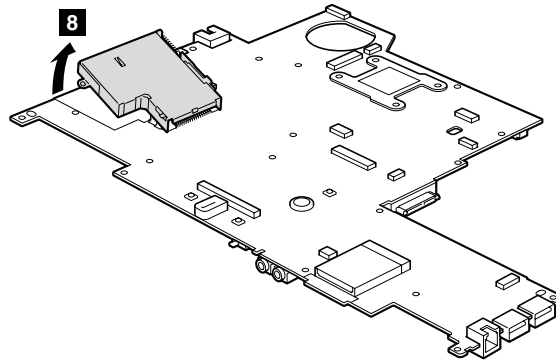

1180 Speakers and base cover

For access, remove these FRUs in order:

- “1010 Battery pack” on page 54
- “1090 Wireless LAN card slot cover and PCI Express Mini Card for wireless LAN” on page 65
- “1110 Keyboard cover and power board” on page 68
- “1130 Keyboard” on page 71
- “1140 LCD unit” on page 73
- “1150 Keyboard bezel and LED board L” on page 76
- “1160 LED board R” on page 79
- “1170 System board and ExpressCard slot assembly” on page 80

Table 28. Removal steps of speakers and base cover

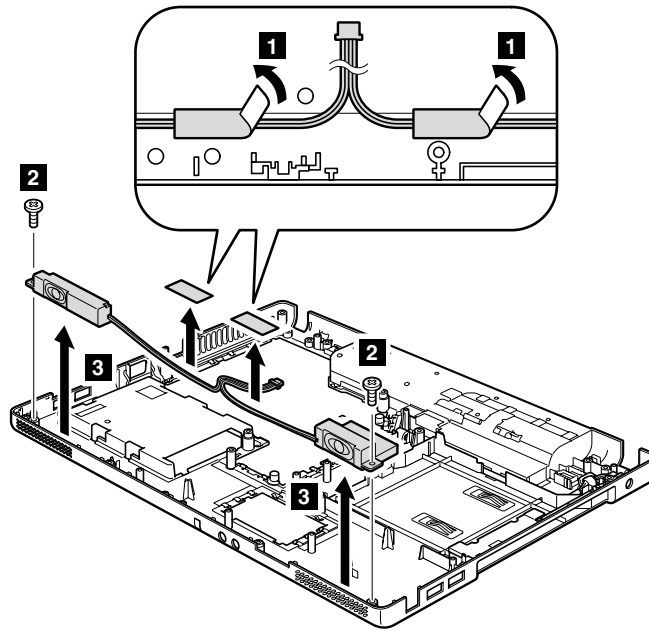

Step	Screw (quantity)	Color	Torque
2	M2.5 × 2 mm, wafer-head, nylon-coated (2)	Black	1.5 Nm (2.0 kgfcm)

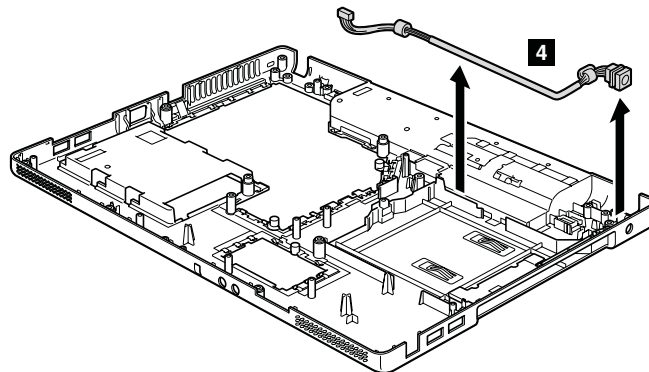

Note: Applying labels to the base cover

The new base cover FRU is shipped with a kit containing labels of several kinds. When you replace the base cover, you need to apply the following label:

- a** Product label

Following labels need to be peeled off from the old base cover, and need to be put on the new base cover.

- b** Israel label
- c** Serial number label
- d** Compal serial number label
- e** MAC address label
- f** Windows license label (COA)

For some models, you also need to apply one or two FCC labels. Check the old base cover; if it has one or two FCC labels, find duplicates of them in the label kit and apply them to the new base cover.

For the location of each label, refer the following figure:

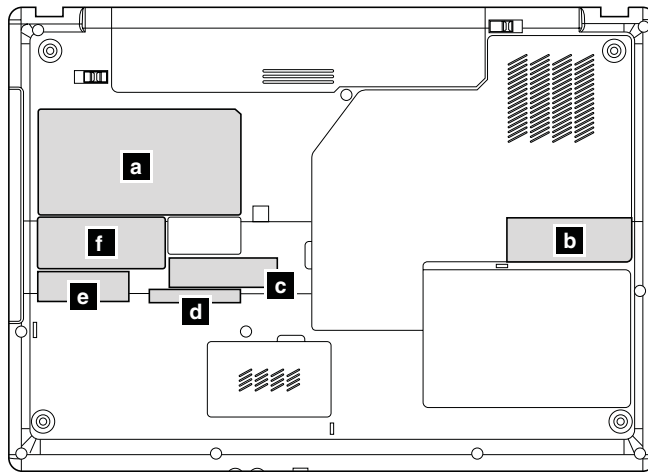



2010 LCD front bezel

For access, remove these FRUs in order:

- “1010 Battery pack” on page 54
- “1090 Wireless LAN card slot cover and PCI Express Mini Card for wireless LAN” on page 65
- “1110 Keyboard cover and power board” on page 68
- “1130 Keyboard” on page 71
- “1140 LCD unit” on page 73

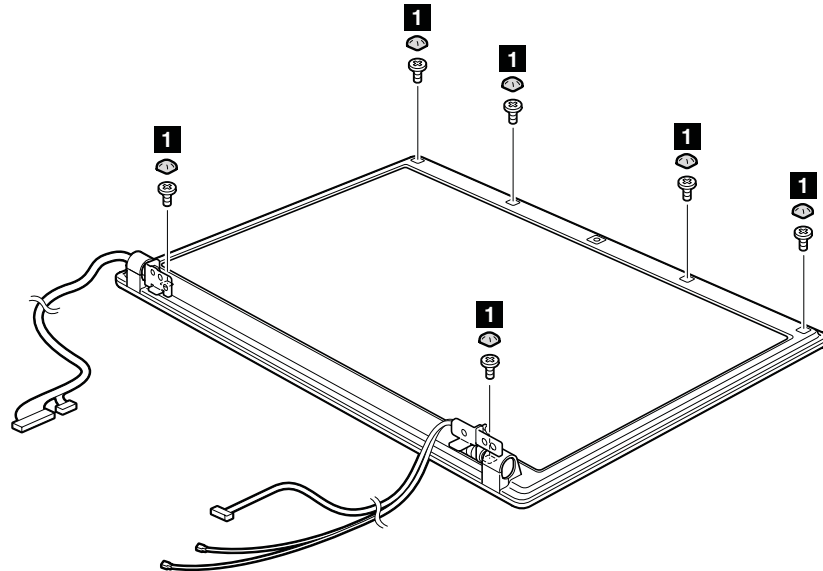
Table 29. Removal steps of LCD front bezel



Step	Screw cap	Screw (quantity)	Color	Torque
1		M2.5 × 4 mm, bind-head, nylon-coated (6)	Black	2.0 Nm (2.5 kgfcm)

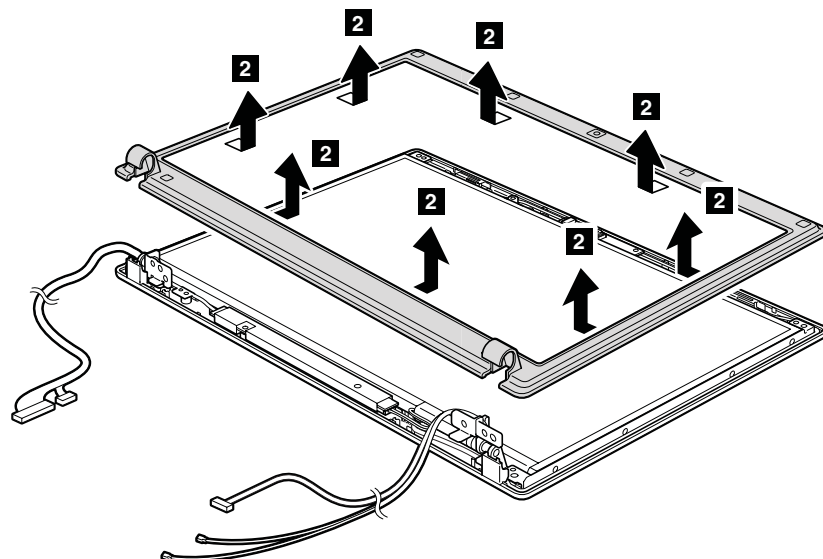

2020 Inverter card

For access, remove these FRUs in order:

- “1010 Battery pack” on page 54
- “1090 Wireless LAN card slot cover and PCI Express Mini Card for wireless LAN” on page 65
- “1110 Keyboard cover and power board” on page 68
- “1130 Keyboard” on page 71
- “1140 LCD unit” on page 73
- “2010 LCD front bezel” on page 86

Table 30. Removal steps of inverter card

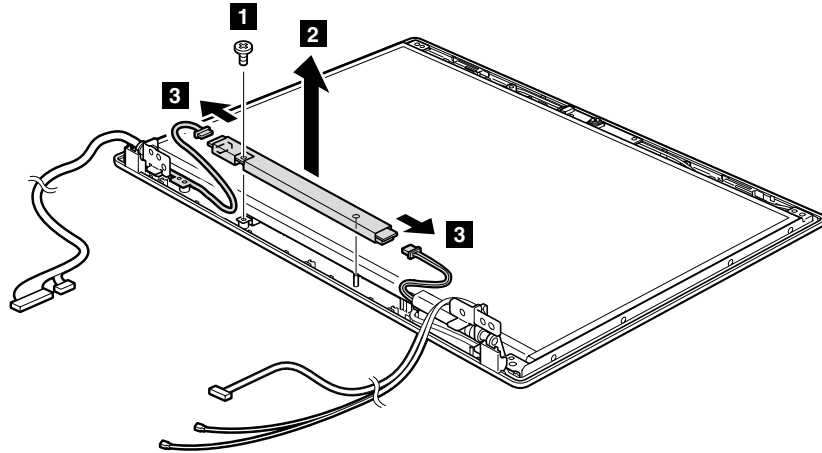

Step	Screw (quantity)	Color	Torque
1	M2.5 × 5 mm, wafer-head, nylon-coated (1)	Black	2.0 Nm (2.5 kgfcm)

2030 Integrated camera

For access, remove these FRUs in order:

- “1010 Battery pack” on page 54
- “1090 Wireless LAN card slot cover and PCI Express Mini Card for wireless LAN” on page 65
- “1110 Keyboard cover and power board” on page 68
- “1130 Keyboard” on page 71
- “1140 LCD unit” on page 73
- “2010 LCD front bezel” on page 86
- “2020 Inverter card” on page 87

Table 31. Removal steps of integrated camera

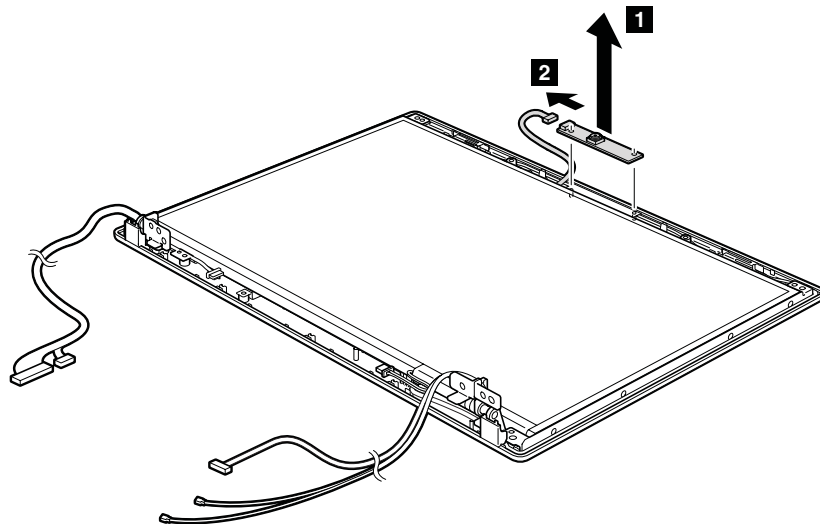

Cable routing: When replacing the inverter card, route the connector cable as in this figure:

2040 LCD panel, LCD cable, and hinges

For access, remove these FRUs in order:

- “1010 Battery pack” on page 54
- “1090 Wireless LAN card slot cover and PCI Express Mini Card for wireless LAN” on page 65
- “1110 Keyboard cover and power board” on page 68
- “1130 Keyboard” on page 71
- “1140 LCD unit” on page 73
- “2010 LCD front bezel” on page 86
- “2020 Inverter card” on page 87
- “2030 Integrated camera” on page 88

Table 32. Removal steps of LCD panel, LCD cable, and hinges

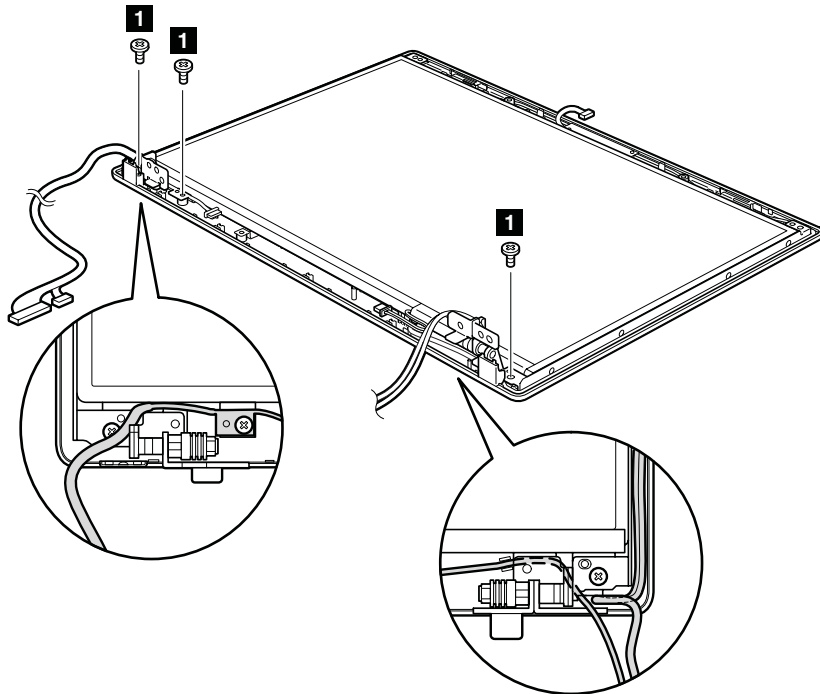

Step	Screw (quantity)	Color	Torque
3	M2.5 × 5 mm, wafer-head, nylon-coated (3)	Black	2.0 Nm (2.5 kgfcm)

Table 32. Removal steps of LCD panel, LCD cable, and hinges (continued)

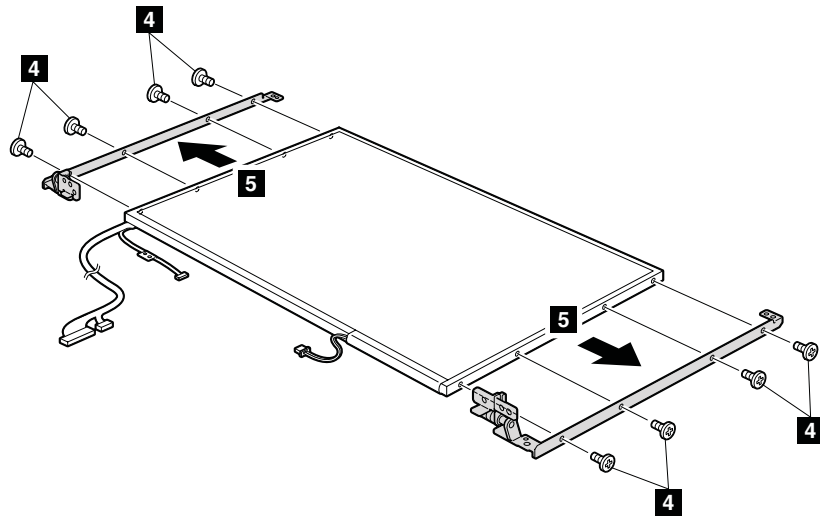
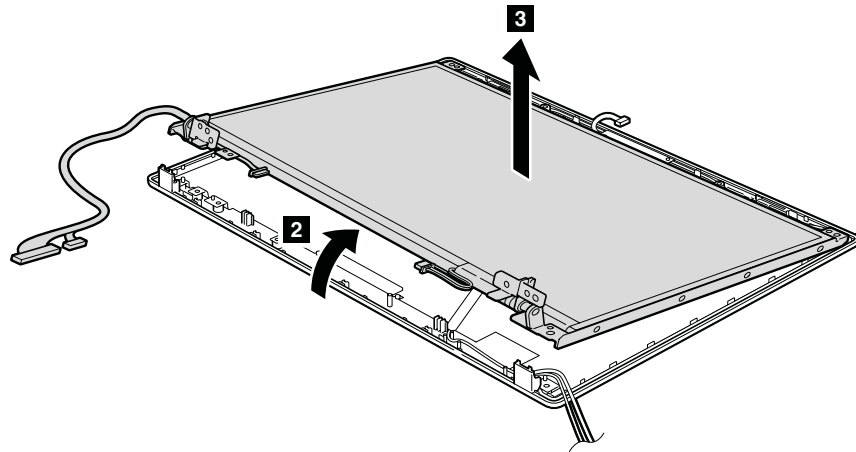

Step	Screw (quantity)	Color	Torque
4	M2 × 3 mm, wafer-head, nylon-coated (8)	Black	1.0 Nm (1.5 kgfcm)

Table 32. Removal steps of LCD panel, LCD cable, and hinges (continued)

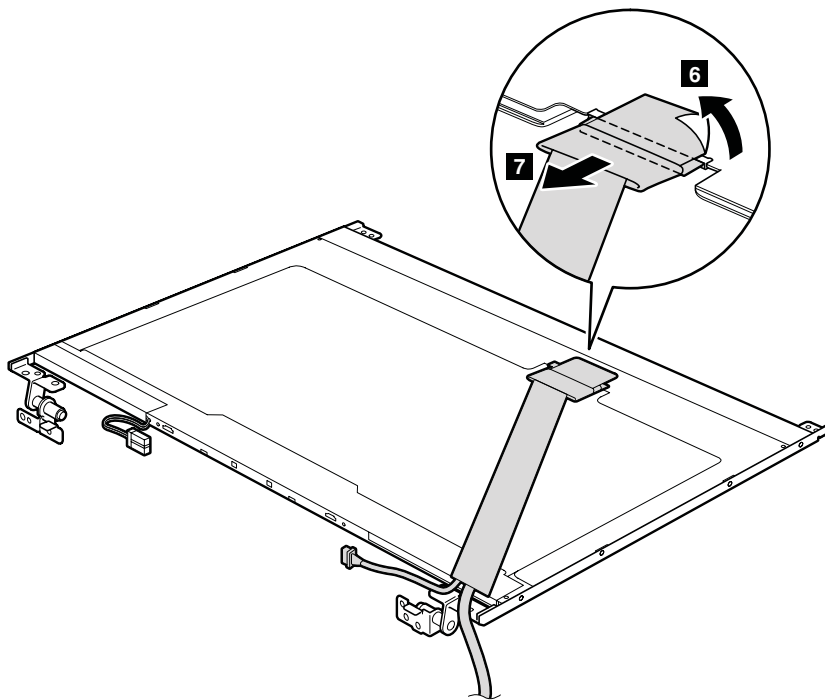

When installing: Make sure that the LCD cable is attached firmly.

2050 Antenna assembly and LCD cover

For access, remove these FRUs in order:

- “1010 Battery pack” on page 54
- “1090 Wireless LAN card slot cover and PCI Express Mini Card for wireless LAN” on page 65
- “1110 Keyboard cover and power board” on page 68
- “1130 Keyboard” on page 71
- “1140 LCD unit” on page 73
- “2010 LCD front bezel” on page 86
- “2020 Inverter card” on page 87
- “2030 Integrated camera” on page 88
- “2040 LCD panel, LCD cable, and hinges” on page 89

Table 33. Removal steps of antenna assembly and LCD cover

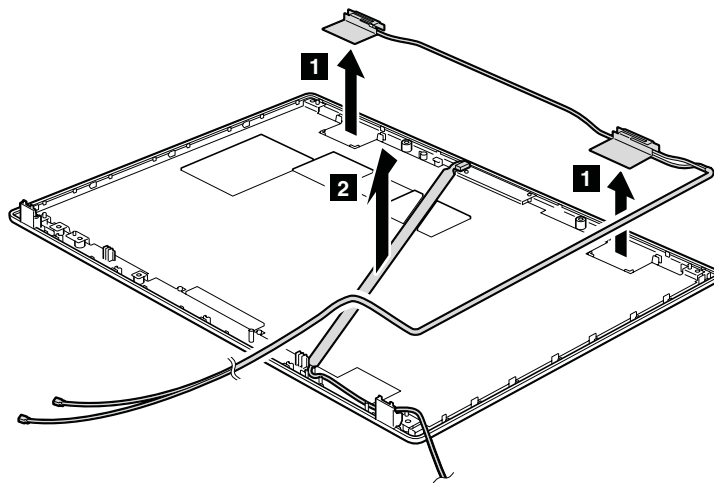

When installing: As you route the cables, make sure that they are not subjected to any tension. Tension could cause the cables to be damaged by the cable guides, or a wire to be broken.

Locations

Front view

- 1** Integrated camera (for some models)
- 2** Touch sensor/volume control buttons
- 3** Status indicators
Note: For the description of each indicator, see “Status indicators” on page 45.
- 4** AC power jack
- 5** Optical drive
- 6** USB (Universal serial bus) connectors
- 7** RJ-11 (modem) jack
- 8** Stereo speakers
- 9** Multi-media reader slot
- 10** Stereo headphone jack
- 11** Microphone jack
- 12** Wireless radio switch
- 13** Touch pad buttons
- 14** Touch pad
- 15** Power button
- 16** Lenovo Care button

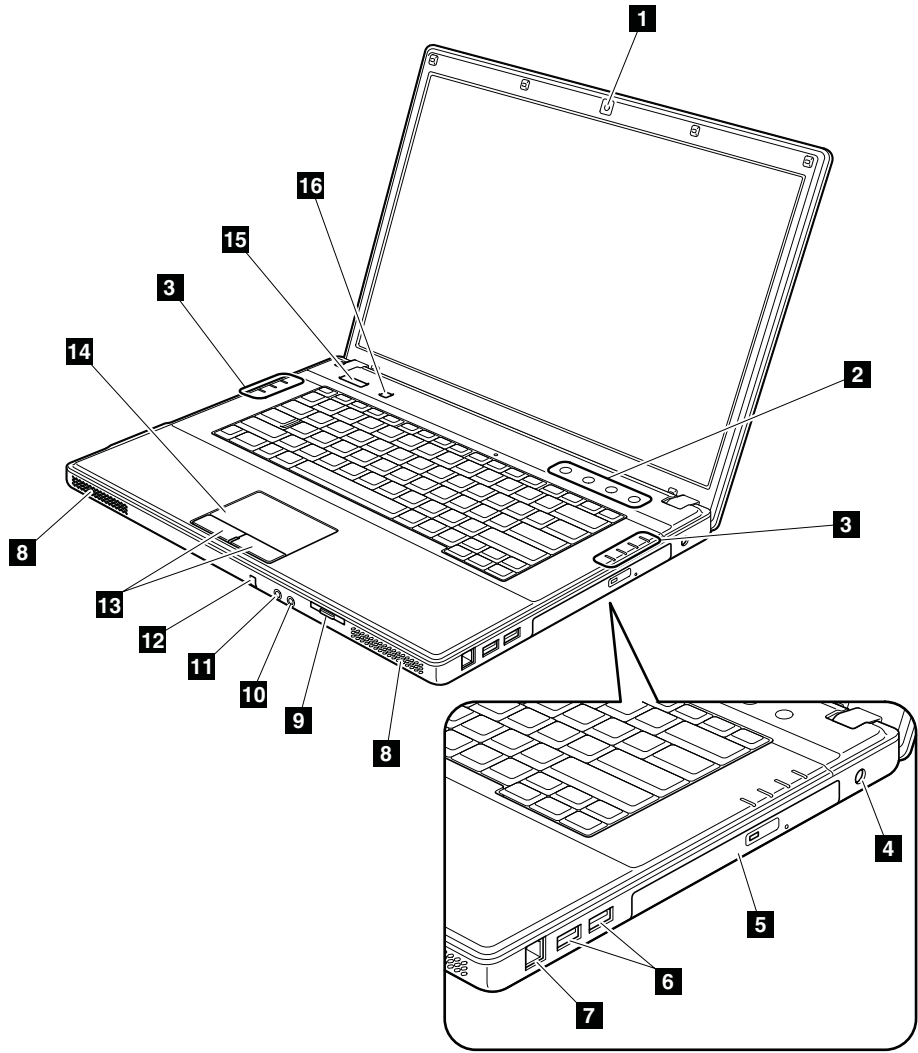

Rear view

- 1** PCI Express Card slot
- 2** USB (Universal serial bus) connectors
- 3** VGA port
- 4** RJ-45 (Ethernet) jack
- 5** Security key hole

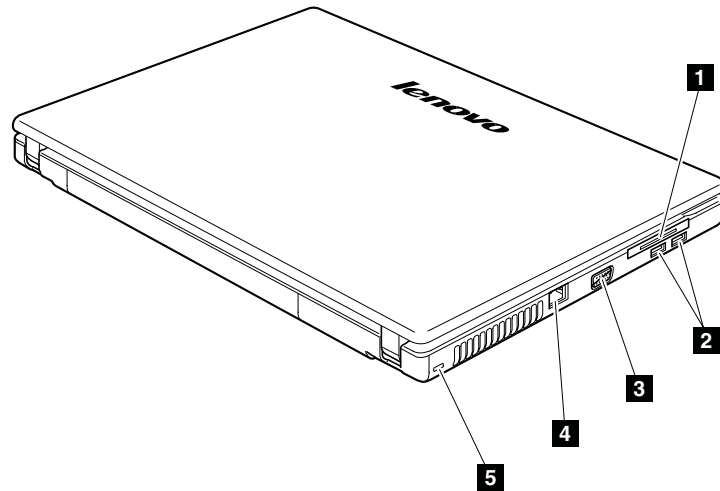

Bottom view

- 1** Battery pack latch (manual)
- 2** Battery pack
- 3** Battery pack latch (spring loaded)
- 4** CPU and DIMM compartment
- 5** Hard disk drive compartment
- 6** Wireless LAN card compartment

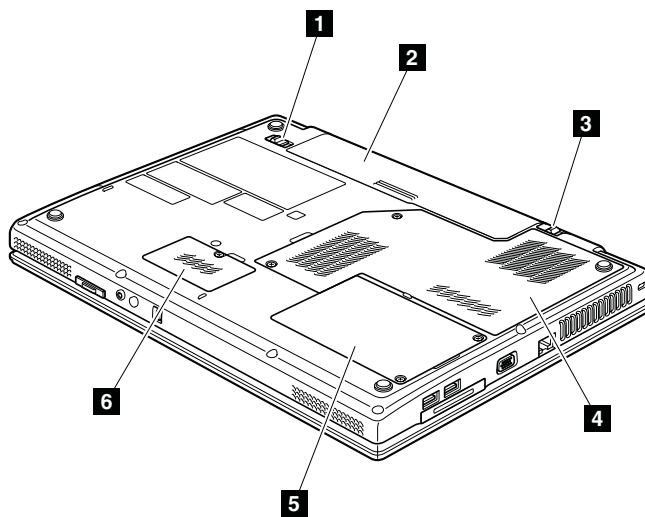

Parts list

This section contains following lists of the service parts.

- “Overall” on page 97
- “LCD FRUs” on page 101
- “Keyboard” on page 103
- “Miscellaneous parts” on page 104
- “AC adapters” on page 105
- “Power cords” on page 106
- “Recovery discs” on page 107
- “Common service tools” on page 111

Notes:

- Each FRU is available for all types or models, unless specific types or models are specified.
- FRU with specific models listed and described as xxU (where U is an example of a country designator) should be used for all models ending in U.
- FRU with specific models listed and described as 3Dx (where 3D is an example of a unique configuration) should be used for all of these models, unless specific country or region designator is specified.
- A CRU (customer replaceable unit) is identified by a single asterisk (*) or two asterisks (**) in the CRU ID column. An N in the CRU ID column means that the part is not a CRU. A single asterisk (*) means that the part is a Self-service CRU; two asterisks (**) means that the part is an Optional-service CRU.

Lenovo 3000 computers contain the following types of CRUs:

Self-service CRUs

These CRUs unplug or are held by no more than two screws.

Examples of these types of CRUs include an AC adapter, a power cord, a battery, and a hard disk drive. Other Self-service CRUs depending on product design may include a memory, a wireless card, a keyboard, and a palm rest with finger print reader and touchpad.

Optional-service CRUs

These CRUs are isolated parts within the computer that are concealed by an access panel that is typically secured by more than two screws.

Once the access panel is removed, the specific CRU is visible.

- A RoHS compliant FRU is identified by an R. An N in the RoHS ID column means the part is not a RoHS compliant FRU.
- FRUs marked with **OP** are available as options.

Overall

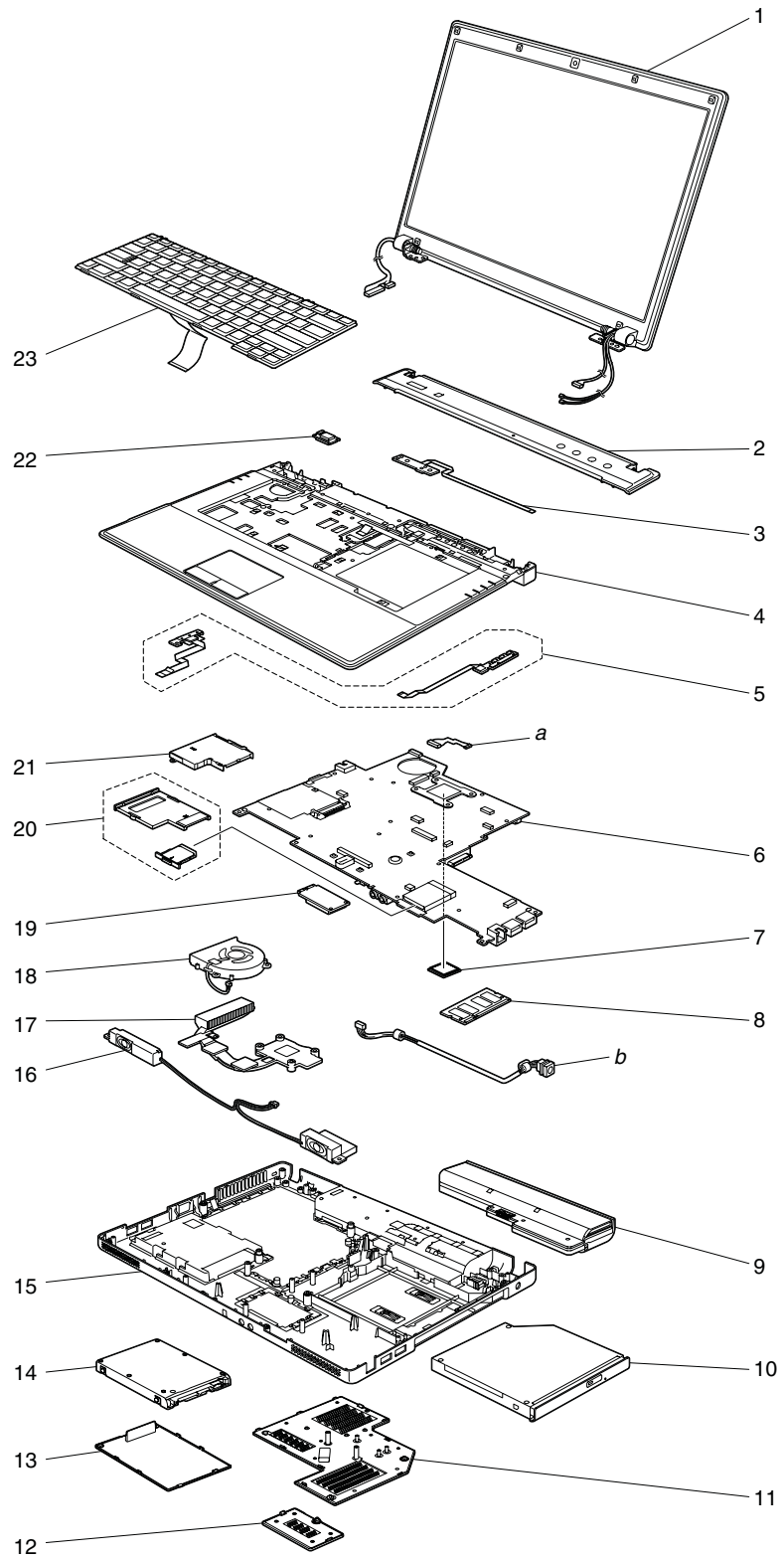

Table 34. Parts list—Overall

No.	FRU	FRU no.	RoHS ID	CRU ID
<i>a - d</i>	See “Miscellaneous parts” on page 104.			
1	LCD unit (see “LCD FRUs” on page 101.)			
2	Keyboard cover	43N8371	R	N
3	Power board with cable	43N8372	R	N
4	Keyboard bezel assembly with touch pad	43N8369	R	N
5	LED boards with cable	43N8376	R	N
6	System board assembly with HDMI, Intel integrated graphics X4500 • 4233-CTO, 33x, 34x, 35x, 36x, 37x	43N8340	R	N
6	System board assembly with HDMI, AMD M86 Hybrid 256 MB • 4233-CTO, 3Dx, 3Ex	43N8344	R	N
6	System board assembly with HDMI, AMD M86GL Hybrid 512 MB • 4233-CTO, 32x, 38x, 39x, 3Ax, 3Bx, 3Cx	43N8348	R	N
7	CPU assembly, Intel Celeron M processor 575 • 4233-CTO, 32x	42W8034	R	N
7	CPU assembly, Intel Celeron M processor 585 • 4233-CTO	42W8033	R	N
7	CPU assembly, Intel Pentium dual-core processor T3200 (2.0 GHz) • 4233-CTO, 33x, 34x, 38x, 39x	43N8360	R	N
7	CPU assembly, Intel Pentium dual-core processor T3400 (2.16 GHz) • 4233-CTO, 35x, 36x, 3Ax, 3Bx	43N8359	R	N
7	CPU assembly, Intel Core 2 Duo processor P7350 (2.0 GHz) • 4233-CTO	42W8032	R	N
7	CPU assembly, Intel Core 2 Duo processor P8400 (2.26 GHz) • 4233-CTO	42W7984	R	N
7	CPU assembly, Intel Core 2 Duo processor P8600 (2.40 GHz) • 4233-CTO	42W7985	R	N
7	CPU assembly, Intel Core 2 Duo processor P9500 (2.53 GHz) • 4233-CTO	42W7986	R	N
7	CPU assembly, Intel Core 2 Duo processor T5670 (1.8 GHz) • 4233-CTO	43N7741	R	N
7	CPU assembly, Intel Core 2 Duo processor T5800 (2.0 GHz) • 4233-CTO	43N8359	R	N
7	CPU assembly, Intel Core 2 Duo processor T5900 (2.20 GHz) • 4233-CTO	43N8352	R	N

Table 34. Parts list—Overall (continued)

No.	FRU	FRU no.	RoHS ID	CRU ID
7	CPU assembly, Intel Core 2 Duo processor T9400 (2.53 GHz) • 4233-CTO	42W7987	R	N
7	CPU assembly, Intel Core 2 Duo processor T9600 (2.80 GHz) • 4233-CTO	42W7988	R	N
8	1-GB DDR2-667 SDRAM SO-DIMM (PC2-5300) card • 4233-CTO, 32x, 33x, 34x, 35x, 36x, 37x, 38x, 39x, 3Ax, 3Bx, 3Cx, 3Dx, 3Ex	43N8353	R	**
8	2-GB DDR2-667 SDRAM SO-DIMM (PC2-5300) card • 4233-CTO	43N8354	R	**
9	Battery pack, Li-ion (6 cell, 2.4 Ah) • 4233-CTO, 32x, 33x, 34x, 35x, 36x, 37x, 38x, 39x, 3Ax, 3Bx, 3Cx, 3Dx, 3Ex	42T4581	R	*
9	Battery pack, Li-ion (6 cell, 2.4 Ah) • 4233-CTO, 32x, 33x, 34x, 35x, 36x, 37x, 38x, 39x, 3Ax, 3Bx, 3Cx, 3Dx, 3Ex	42T4583	R	*
9	Battery pack, Li-ion (6 cell, 2.4 Ah) • 4233-CTO, 32x, 33x, 34x, 35x, 36x, 37x, 38x, 39x, 3Ax, 3Bx, 3Cx, 3Dx, 3Ex	42T4585	R	*
9	Battery pack, Li-ion (6 cell, 2.6 Ah) • 4233-CTO	42T4575	R	*
9	Battery pack, Li-ion (6 cell, 2.6 Ah) • 4233-CTO	42T4577	R	*
9	Battery pack, Li-ion (6 cell, 2.6 Ah) • 4233-CTO	42T4579	R	*
10	DVD/CD-RW combo drive • 4233-CTO	43N8404	R	**
10	DVD/CD-RW combo drive • 4233-CTO	43N8405	R	**
10	DVD-RAM/RW drive • 4233-CTO, 32x, 33x, 34x, 35x, 36x, 37x, 38x, 39x, 3Ax, 3Bx, 3Cx, 3Dx, 3Ex	43N8406	R	**
10	DVD-RAM/RW drive • 4233-CTO, 32x, 33x, 34x, 35x, 36x, 37x, 38x, 39x, 3Ax, 3Bx, 3Cx, 3Dx, 3Ex	43N8407	R	**
11	Thermal slot cover (UMA) • 4233-CTO, 32x, 33x, 34x, 35x, 36x, 37x, 38x, 39x, 3Ax, 3Bx, 3Cx	43N8379	R	
11	Thermal slot cover (discrete) • 4233-CTO, 3Dx, 3Ex	43N8368	R	
12	Wireless LAN card slot cover	43N8381	R	*
13	Hard disk drive slot cover	43N8380	R	*
14	SATA Hard disk drive assembly, 120 GB 5,400 rpm • 4233-CTO	43N8389	R	*
14	SATA Hard disk drive assembly, 120 GB 5,400 rpm • 4233-CTO	43N8390	R	*

Table 34. Parts list—Overall (continued)

No.	FRU	FRU no.	RoHS ID	CRU ID
14	SATA Hard disk drive assembly, 120 GB 5,400 rpm • 4233-CTO	43N8391	R	*
14	SATA Hard disk drive assembly, 160 GB 5,400 rpm • 4233-CTO, 32x, 33x, 34x, 35x, 36x, 38x, 39x, 3Ax, 3Bx	43N8393	R	*
14	SATA Hard disk drive assembly, 160 GB 5,400 rpm • 4233-CTO, 32x, 33x, 34x, 35x, 36x, 38x, 39x, 3Ax, 3Bx	43N8394	R	*
14	SATA Hard disk drive assembly, 160 GB 5,400 rpm • 4233-CTO, 32x, 33x, 34x, 35x, 36x, 38x, 39x, 3Ax, 3Bx	43N8395	R	*
14	SATA Hard disk drive assembly, 250 GB 5,400 rpm • 4233-CTO, 37x, 3Cx, 3Dx, 3Ex	43N8397	R	*
14	SATA Hard disk drive assembly, 250 GB 5,400 rpm • 4233-CTO, 37x, 3Cx, 3Dx, 3Ex	43N8398	R	*
14	SATA Hard disk drive assembly, 250 GB 5,400 rpm • 4233-CTO, 37x, 3Cx, 3Dx, 3Ex	43N8399	R	*
14	SATA Hard disk drive assembly, 320 GB 5,400 rpm • 4233-CTO	43N8401	R	*
14	SATA Hard disk drive assembly, 320 GB 5,400 rpm • 4233-CTO	43N8403	R	*
15	Base cover assembly	43N8370	R	N
16	Speakers	43N8378	R	N
17	Heat sink assembly (integrated) • 4233-CTO, 32x, 33x, 34x, 35x, 36x, 37x, 38x, 39x, 3Ax, 3Bx, 3Cx	43N8373	R	N
17	Heat sink assembly (discrete) • 4233-CTO, 3Dx, 3Ex	43N8374	R	N
18	Fan assembly	43N8375	R	N
19	Intel WiFi Link 5100 • 4233-CTO, 32x, 33x, 34x, 35x, 36x, 37x, 38x, 39x, 3Ax, 3Bx, 3Cx, 3Dx, 3Ex	43Y6493	R	**
19	Lenovo 802.11b/g Wireless LAN Mini-PCI Express Adapter • 4233-CTO	43Y6487	R	**
19	Lenovo 802.11b/g Wireless LAN Mini-PCI Express Adapter • 4233-CTO	43Y6480	R	**
20	Dummy cards	43N8382	R	*
21	ExpressCard slot	43N8377	R	N
22	Bluetooth daughter card (BDC-2)	43Y6491	R	N
23	Keyboard (see “Keyboard” on page 103.)			
—	Thermal grease	91P8835	R	N
—	AC adapter (see “AC adapters” on page 105.)			

LCD FRUs

In Lenovo 3000 N500, there are following types of LCDs.

- “15.4-in. WXGA TFT”

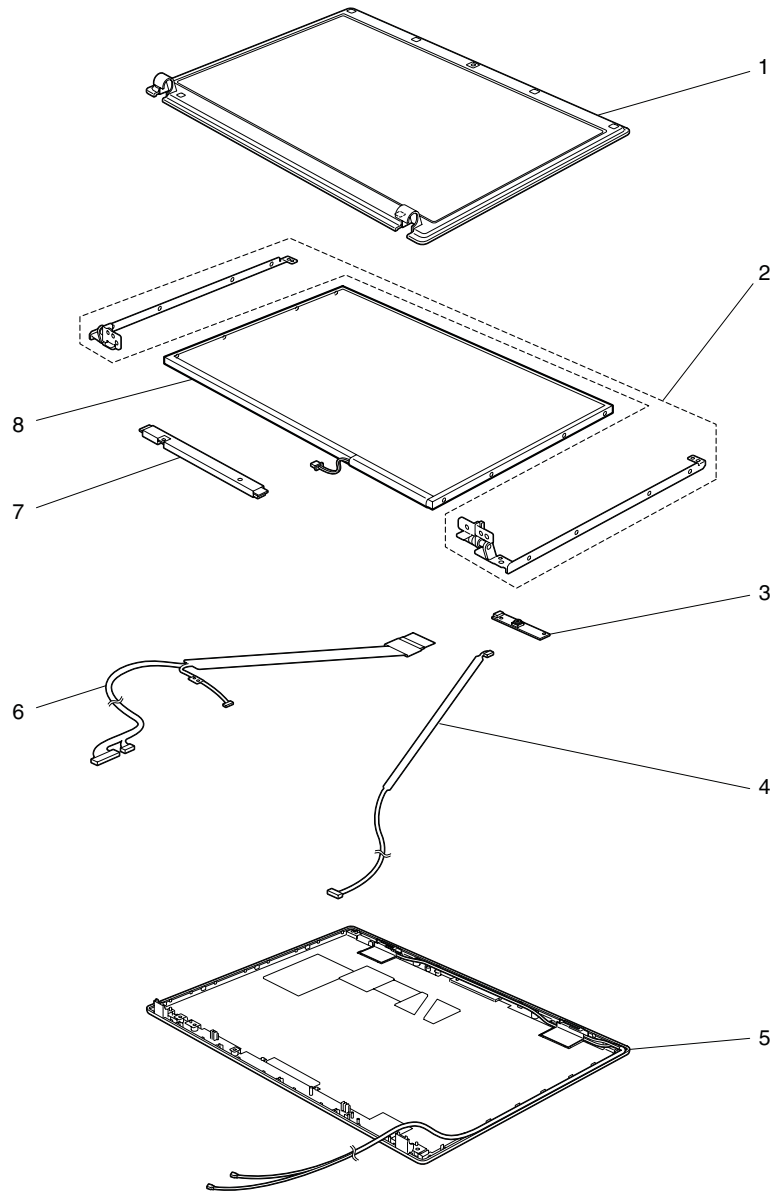

15.4-in. WXGA TFT

Table 35. Parts list—15.4-in. WXGA TFT

No.	FRU	FRU no.	RoHS ID	CRU ID
1	LCD front bezel	43N8363	R	N
2	Hinges	43N8364	R	N
3	Camera module <ul style="list-style-type: none"> • 4233-CTO, 32x, 33x, 34x, 35x, 36x, 37x, 38x, 39x, 3Ax, 3Bx, 3Cx, 3Dx, 3Ex 	43N8367	R	N

Table 35. Parts list—15.4-in. WXGA TFT (continued)

No.	FRU	FRU no.	RoHS ID	CRU ID
4	RTC cable for camera • 4233-CTO, 32x, 33x, 34x, 35x, 36x, 37x, 38x, 39x, 3Ax, 3Bx, 3Cx, 3Dx, 3Ex	43N8366	R	N
5	LCD cover	43N8362	R	N
6	LCD cable assembly	43N8365	R	N
7	Inverter card	43N8355	R	N
7	Inverter card	43N8356	R	N
7	Inverter card	43N8357	R	N
8	LCD panel, 15.4-in. WXGA Glare	42T0625	R	N
8	LCD panel, 15.4-in. WXGA Glare	42T0627	R	N
8	LCD panel, 15.4-in. WXGA Glare	42T0629	R	N
8	LCD panel, 15.4-in. WXGA Glare	42T0631	R	N

Keyboard

Table 36.

Language	P/N		RoHS ID	CRU ID
Arabic	42T3353	42T3418	R	**
Belgian	42T3350	42T3415		
Canadian French (058)	42T3340	—		
Canadian French (Acnor)	—	42T3404		
Czech	42T3358	42T3423		
Danish	42T3347	42T3412		
Dutch	42T3344	42T3409		
Finnish, Swedish	42T3345	42T3410		
French	42T3343	42T3408		
German	42T3341	42T3406		
Greek (U.S. English and Greek layout)	42T3360	42T3425		
Hebrew	42T3355	42T3420		
Hungarian	42T3359	42T3424		
Icelandic	42T3370	—		
Italian	42T3348	42T3413		
Latin American Spanish	42T3366	42T3431		
Norwegian	42T3346	42T3411		
Polish	42T3356	42T3421		
Portuguese	42T3352	42T3417		
Russian	42T3354	42T3419		
Slovak	42T3362	42T3427		
Slovenian	42T3361	42T3426		
Spanish	42T3349	42T3414		
Swiss	42T3351	42T3416		
Turkish	42T3357	42T3422		
U.K. English	42T3342	42T3407		
U.S. English	42T3338	42T3403		
U.S. English (International, with a Euro symbol)	42T3368	42T3433		

Miscellaneous parts

Table 37. Parts list—Miscellaneous parts

FRU	P/N	RoHS ID	CRU ID
Screw kit (including nylon-coated screws): <ul style="list-style-type: none"> • M2 × 2.5 mm (black), wafer head (8) • M2 × 3 mm (black), wafer head (12) • M2 × 3 mm (silver), wafer head (6) • M2 × 4 mm (black), wafer head (2) • M2.5 × 5 mm (black), wafer head (20) • M2.5 × 5 mm (silver), wafer head (3) • M2.5 × 8 mm (black), wafer head (14) • M2.5 × 10 mm (black), wafer head (1) • M2.5D 5.7+2L K 6.0D (black) (4) • M3 × 3 mm (silver), wafer head (4) 	43N8385	R	N
System miscellaneous parts: <ul style="list-style-type: none"> • Optical drive bracket • HDD bracket • Foot rubber • LCD bezel screw rubber 	43N8383	R	N
Cable miscellaneous parts: <ul style="list-style-type: none"> • (a) <i>Bluetooth</i> cable • (b) ***** • Microphone cable • Touch sensor board cable • Touch pad cable <p>Note: Italicized letters in parentheses are references to the exploded view in “Overall” on page 97.</p>	43N8384	R	N
Label kit	43N8386	R	N

AC adapters

Table 38. Parts list—3-pin AC adapters

FRU	P/N	RoHS ID	CRU ID
3-pin (90 W, 20 V) adapter (models CTO, xxA, xxB, xxC, xxG, xxH, xxK, xxM, xxT, xxV)	92P1104	R	*
3-pin (90 W, 20 V) adapter (models CTO, xxA, xxB, xxC, xxG, xxH, xxK, xxM, xxT, xxV)	42T5275		
3-pin (90 W, 20 V) adapter (models CTO, xxA, xxB, xxC, xxG, xxH, xxK, xxM, xxT, xxV)	92P1108		
3-pin (65W, 20 V) adapter (models CTO, xxA, xxB, xxC, xxG, xxH, xxK, xxM, xxT, xxV) OP	42T5283		
3-pin (65W, 20 V) adapter (models CTO, xxA, xxB, xxC, xxG, xxH, xxK, xxM, xxT, xxV)	92P1212		
3-pin (65W, 20 V) adapter (models CTO, xxA, xxB, xxC, xxG, xxH, xxK, xxM, xxT, xxV)	92P1157		
3-pin (65W, 20 V) adapter (models CTO, xxY)	42T5017		
3-pin (65W, 20 V) adapter (models CTO, xxY)	42T5102		

Power cords

A Lenovo 3000 power cord for a specific country or region is usually available only in that country or region:

Table 39. Parts list—2-pin power cords

Region	P/N		RoHS ID	CRU ID
Argentina • models -CTO, xxY	42T5020	42T5105	R	*
Brazil • models -CTO, xxP	42T5180	42T5183		
Canada, U.S. • models -CTO, xxF, xxL, xxS, xxU	42T5008	42T5093		
Japan • models -Exx, Jxx	42T5014	42T5099		

Table 40. Parts list—3-pin power cords

Region	P/N		RoHS ID	CRU ID
Australia, New Zealand • models -CTO, xxG, xxM	42T5050	42T5135	R	*
Bangladesh, Sri Lanka, South Africa • models -CTO, xxG	42T5056	42T5141		
Canada, U.S. • models -CTO, xxF, xxL, xxS, xxU	42T5004	42T5089		
China (P.R.C.) (other than Hong Kong S.A.R.) • models -xxC	42T5065	42T5150		
Denmark • models -CTO, xxG	42T5041	42T5126		
European countries • models -CTO, xxG	42T5029	42T5114		
India • models -CTO, xxG	42T5083	42T5168		
Israel • models -CTO, xxG	42T5062	42T5147		
Italy • models -CTO, xxG	42T5047	42T5132		
Korea • models -xxK	42T5077	42T5162		
Switzerland • models -CTO, xxG	42T5044	42T5129		
Taiwan • models -CTO, xxV	42T5071	42T5156		
U.K., China (Hong Kong S.A.R.) • models -CTO, xxB, xxG, xxH	42T5035	42T5120		

Recovery discs

Windows XP Professional DVDs

For the following models, Windows XP Professional DVDs are prepared:

- 4233-CTO, 24x, 25x, 36x, 3Bx, 3Ex

Table 41. Parts list—Windows XP Professional recovery DVDs

Language	P/N	RoHS ID	CRU ID
Arabic	56Y0093	R	N
Czech	56Y0094		
Danish	56Y0095		
Dutch	56Y0096		
English	56Y0110		
English (modem-disabled)	56Y0111		
Finnish	56Y0097		
French	56Y0098		
German	56Y0099		
Greek	56Y0100		
Hebrew	56Y0101		
Hungarian	56Y0102		
Italian	56Y0103		
Norwegian	56Y0104		
Polish	56Y0105		
Russian	56Y0112		
Russian (English-enabled)	56Y0113		
Slovenian	56Y0106		
Spanish	56Y0107		
Swedish	56Y0108		
Turkish	56Y0109		

Windows Vista Home Basic (32 bit) DVDs

Windows Vista Home Basic (32 bit) is preinstalled as the operating system in the following models:

- 4233-CTO, 22x, 32x, 34x, 39x

Table 42. Parts list—Windows Vista Home Basic (32 bit) DVDs

Language	P/N	RoHS ID	CRU ID
Czech	56Y0024	R	N
Danish	56Y0025		
English	56Y0040		
English (modem-disabled)	56Y0042		
French	56Y0026		
German	56Y0027		
Greek	56Y0028		
Hebrew	56Y0029		
Hungarian	56Y0030		
Italian	56Y0031		
Norwegian	56Y0032		
Polish	56Y0033		
Romanian	56Y0035		
Portuguese	56Y0034		
Russian	56Y0043		
Russian (English-enabled)	56Y0044		
Serbian-Latin	56Y0041		
Slovak	56Y0037		
Slovenian	56Y0036		
Spanish	56Y0038		
Turkish	56Y0039		

Windows Vista Home Premium (32 bit) DVDs

Windows Vista Home Premium (32 bit) is preinstalled as the operating system in the following models:

- 4233-CTO, 23x, 35x, 37x, 3Ax, 3Cx, 3Dx

Table 43. Parts list—Windows Vista Home Premium (32 bit) DVDs

Language	P/N	RoHS ID	CRU ID
Czech	56Y0024	R	N
Danish	56Y0025		
English	56Y0040		
English (modem-disabled)	56Y0042		
French	56Y0026		
German	56Y0027		
Greek	56Y0028		
Hebrew	56Y0029		
Hungarian	56Y0030		
Italian	56Y0031		
Norwegian	56Y0032		
Polish	56Y0033		
Romanian	56Y0035		
Portuguese	56Y0034		
Russian	56Y0043		
Russian (English-enabled)	56Y0044		
Serbian-Latin	56Y0041		
Slovak	56Y0037		
Slovenian	56Y0036		
Spanish	56Y0038		
Turkish	56Y0039		

Windows Vista Business (32 bit) DVDs

Windows Vista Business (32 bit) is preinstalled as the operating system in the following models:

- 4233-CTO, 24x, 25x, 36x, 3Bx, 3Ex

Table 44. Parts list—Windows Vista Business (32 bit) DVDs

Language	P/N	RoHS ID	CRU ID
Czech	56Y0000	R	N
Danish	56Y0001		
English	56Y0016		
English (modem-disabled)	56Y0018		
French	56Y0002		
German	56Y0003		
Greek	56Y0004		
Hebrew	56Y0005		
Hungarian	56Y0006		
Italian	56Y0007		
Norwegian	56Y0008		
Polish	56Y0009		
Romanian	56Y0011		
Portuguese	56Y0010		
Russian	56Y0019		
Russian (English-enabled)	56Y0020		
Serbian-Latin	56Y0017		
Slovak	56Y0013		
Slovenian	56Y0012		
Spanish	56Y0014		
Turkish	56Y0015		

Common service tools

Table 45. Parts list—Common service tools

Tool	P/N
Screwdriver kit	95F3598
1/4" drive spinner handle	1650840
1/4" Sq. to 1/4" hex torx adapter	93F2838
TR7-TR-10 tamper resistant torx bits	00P6967
Removal tool antenna RF connector	08K7159
USB 2.0 CD-RW/DVD-ROM combo drive II	40Y8687
USB cable	40Y8704
USB floppy diskette drive for maintenance diskette	05K9283
USB floppy diskette drive tool kit	27L3452
Test card for integrated Smart Card	42W7820
CE Utility Diskette for Lenovo 3000 notebooks Note: Download the file from the following Web site: http://www.lenovo.com/spm	—

Notices

Lenovo may not offer the products, services, or features discussed in this document in all countries. Consult your local Lenovo representative for information on the products and services currently available in your area. Any reference to a Lenovo product, program, or service is not intended to state or imply that only that Lenovo product, program, or service may be used. Any functionally equivalent product, program, or service that does not infringe any Lenovo intellectual property right may be used instead. However, it is the user's responsibility to evaluate and verify the operation of any other product, program, or service.

Lenovo may have patents or pending patent applications covering subject matter described in this document. The furnishing of this document does not give you any license to these patents. You can send license inquiries, in writing, to:

*Lenovo (United States), Inc.
1009 Think Place - Building One
Morrisville, NC 27560
U.S.A.
Attention: Lenovo Director of Licensing*

LENOVO GROUP LTD. PROVIDES THIS PUBLICATION "AS IS" WITHOUT WARRANTY OF ANY KIND, EITHER EXPRESS OR IMPLIED, INCLUDING, BUT NOT LIMITED TO, THE IMPLIED WARRANTIES OF NON-INFRINGEMENT, MERCHANTABILITY OR FITNESS FOR A PARTICULAR PURPOSE. Some jurisdictions do not allow disclaimer of express or implied warranties in certain transactions, therefore, this statement may not apply to you.

This information could include technical inaccuracies or typographical errors. Changes are periodically made to the information herein; these changes will be incorporated in new editions of the publication. Lenovo may make improvements and/or changes in the product(s) and/or the program(s) described in this publication at any time without notice.

The products described in this document are not intended for use in implantation or other life support applications where malfunction may result in injury or death to persons. The information contained in this document does not affect or change Lenovo product specifications or warranties. Nothing in this document shall operate as an express or implied license or indemnity under the intellectual property rights of Lenovo or third parties. All information contained in this document was obtained in specific environments and is presented as an illustration. The result obtained in other operating environments may vary.

Lenovo may use or distribute any of the information you supply in any way it believes appropriate without incurring any obligation to you.

Any references in this publication to non-Lenovo Web sites are provided for convenience only and do not in any manner serve as an endorsement of those Web sites. The materials at those Web sites are not part of the materials for this Lenovo product, and use of those Web sites is at your own risk.

Any performance data contained herein was determined in a controlled environment. Therefore, the result obtained in other operating environments may

vary significantly. Some measurements may have been made on development-level systems and there is no guarantee that these measurements will be the same on generally available systems. Furthermore, some measurements may have been estimated through extrapolation. Actual results may vary. Users of this document should verify the applicable data for their specific environment.

Trademarks

The following terms are trademarks of Lenovo in the United States, other countries or both:

- Lenovo®
- Lenovo CareSM
- Rescue and Recovery®
- ThinkVantage®

The following terms are trademarks of the International Business Machines Corporation in the United States, other countries, or both:

- IBM (used under license)

The following terms are trademarks of Microsoft Corporation in the United States, other countries, or both:

- Windows®
- Windows Vista®

The following are trademarks of Intel Corporation or its subsidiaries in the United States, other countries, or both:

- Intel®
- Intel® Core™ 2 Duo

Other company, product, or service names may be the trademarks or service marks of others.

lenovo

Part Number: 45N3577

(1P) P/N: 45N3577

