



ideacentre 510S

Hardware Maintenance Manual

Machine Types: 90KB [510S-07ICB/Energy Star]

Note: Before using this information and the product it supports, be sure to read and understand Chapter 1 “Read this first: Important safety information” on page 1.

First Edition (March 2018)

© Copyright Lenovo 2018.

LIMITED AND RESTRICTED RIGHTS NOTICE: If data or software are delivered pursuant to a General Services Administration “GSA” contract, use, reproduction, or disclosure is subject to restrictions set forth in Contract No. GS-35F-05925

Contents

About this manualiii	Hard disk drive boot error	15
Chapter 1. Read this first: Important safety information	1	Power Supply Problems	15
General safety	1	POST error codes	16
Electrical safety	1	Undetermined problems	16
Safety inspection guide	3	Chapter 6. Hardware locations	17
Handling electrostatic discharge-sensitive devices	3	Front view and rear view	17
Grounding requirements	4	Major FRUs and CRUs	19
Safety notices	4	Parts on the main boards	21
Chapter 2. Environment and electrical input	7	Chapter 7. Installing or replacing hardware	25
Chapter 3. General Checkout	9	Handling static-sensitive devices	25
Chapter 4. Using the Setup Utility program	11	Installing or replacing hardware	25
Starting the Setup Utility program	11	Removing the computer covers	25
Enabling or disabling a device	11	Removing the front bezel	26
Enabling or disabling the Automatic Power On features	11	Replacing an optical drive	27
Using BIOS passwords	11	Replacing a hard disk drive	28
Setup Utility program password types	12	Replacing a graphics card	32
Password considerations	12	Replacing the memory module	33
Setting, changing, and deleting a password	12	Replacing the heat sinks	33
Selecting a startup device	12	Replacing the Wi-Fi card	34
Changing the startup device sequence permanently	13	Replacing the card reader	35
Selecting a temporary startup device	13	Replacing the coin-cell battery	36
Exiting the Setup Utility program	13	Replacing the microprocessor	36
Chapter 5. Symptom-to-FRU Index	15	Replacing the system board	37
		Completing the parts replacement	38
		Chapter 8. Additional Service Information	41
		Trademarks	1

About this manual

This manual provides service and reference information for Lenovo® computers listed on the front cover.

Use this manual along with the advanced diagnostic tests to troubleshoot problems.

Important: This manual is intended only for trained service technicians who are familiar with Lenovo computers. Use this manual along with the advanced diagnostic tests to troubleshoot problems effectively. Before servicing a Lenovo computer, be sure to read and understand Chapter 1 “Read this first: Important safety information” on page 1.

Chapter 1. Read this first: Important safety information

This chapter contains the safety information that you must be familiar with.

General safety

Follow these rules to ensure general safety:

- Keep the areas around the computer clear and clean during and after maintenance.
- When lifting any heavy object:
 1. Ensure you can stand safely without slipping.
 2. Distribute the weight of the object equally across both feet.
 3. Lift slowly. Never move suddenly or twist when you attempt to lift.
 4. Lift by standing or by pushing up with your leg muscles; this action removes the strain from the muscles in your back.
Do not attempt to lift any objects that weigh more than 16 kg (35 lb) or objects that you think are too heavy for you.
- Do not perform any action that would create a hazard for the customer, or would make the computer unsafe.
- Before you start the computer, ensure that other service representatives and customer personnel are not in a position that would create a hazard for them.
- Place removed covers and other parts in a safe place, away from all personnel, while you are servicing the computer.
- Keep your tool case away from areas that people may walk through to ensure no-one trips over it.
- Do not wear loose clothing that can be trapped in the moving parts of a machine. Ensure that your sleeves are fastened or rolled up above your elbows. If your hair is long, tie or fasten it back.
- Insert the ends of your necktie or scarf inside clothing or fasten it with a non-conductive clip, approximately 8 centimeters (3 inches) from the end.
- Do not wear jewelry, chains, metal-frame eyeglasses, or metal fasteners for your clothing.
Remember: Metal objects are good electrical conductors.
- Wear safety glasses when you are: hammering, drilling soldering, cutting wire, attaching springs, using solvents, or working in any other conditions that might be hazardous to your eyes.
- After service, reinstall all safety shields, guards, labels, and ground wires. Replace any safety device that is worn or defective.
- Reattach all covers correctly before returning the computer to the customer.

Electrical safety



CAUTION:

Electrical current from power, telephone, and communication cables can be hazardous. To avoid personal injury or equipment damage, disconnect any attached power cords, telecommunication

cables, network cables, and modem cables before you open the computer covers, unless instructed otherwise in the installation and configuration procedures.

Observe the following rules when working on electrical equipment.

Important: Use only approved tools and test equipment. Some hand tools have handles covered with a soft material that does not insulate you when working with live electrical currents. Many customers have rubber floor mats near their equipment that contain small conductive fibers to decrease electrostatic discharge.

- Find the room emergency power-off (EPO) switch, disconnecting switch, or electrical outlet. If an electrical accident occurs, you can then operate the switch or unplug the power cord quickly.
- Do not work alone under hazardous conditions or near equipment that has hazardous voltages.
- Disconnect all power before:
 - Performing a mechanical inspection
 - Working near power supplies
 - Removing or installing Field Replaceable Units (FRUs)
- Before you start to work on the computer, unplug the power cord. If you cannot unplug it, ask the customer to power-off the electrical outlet that supplies power to the machine and to lock the electrical outlet in the off position.
- If you need to work on a computer that has exposed electrical circuits, observe the following precautions:
 - Ensure that another person, familiar with the power-off controls, is near you.
Remember: Another person must be there to switch off the power, if necessary.
 - Use only one hand when working with powered-on electrical equipment; keep the other hand in your pocket or behind your back.
Remember: There must be a complete circuit to cause electrical shock. By observing the above rule, you may prevent a current from passing through your body.
 - When using a tester, set the controls correctly and use the approved probe leads and accessories for that tester.
 - Stand on suitable rubber mats (obtained locally, if necessary) to insulate you from grounds such as metal floor strips and machine frames.

Observe the special safety precautions when you work with very high voltages; these instructions are in the safety sections of the maintenance information. Use extreme care when measuring high voltages.

- Regularly inspect and maintain your electrical hand tools to ensure they are safe to use.
- Do not use worn or broken tools and testers.
- *Never assume* that power has been disconnected from a circuit. First, *check* that it has been powered off.
- Always look carefully for possible hazards in your work area. Examples of these hazards are wet floors, non-grounded power extension cables, conditions that may cause or allow power surges, and missing safety grounds.
- Do not touch live electrical circuits with the reflective surface of a plastic dental mirror. This surface is conductive, and touching a live circuit can cause personal injury and damage to the computer.
- Do not service the following parts with the power on when they are removed from their normal operating positions in a computer:
 - Power supply units
 - Pumps
 - Blowers and fans
 - Motor generatorsand similar units. (This practice ensures correct grounding of the units.)

- If an electrical accident occurs:
 - Use caution; do not become a victim yourself.
 - Switch off power.
 - Send another person to get medical aid.

Safety inspection guide

The intent of this inspection guide is to assist you in identifying potential hazards posed by these products. Each computer, as it was designed and built, had required safety items installed to protect users and service personnel from injury. This guide addresses only those items. However, good judgment should be used to identify potential safety hazards due to attachment of features or options not covered by this inspection guide.

If any hazards are present, you must determine how serious the apparent hazard could be and whether you can continue without first resolving the problem.

Consider the following items and the safety hazards they present:

- Electrical hazards, especially primary power (primary voltage on the frame can cause serious or fatal electrical shock).
- Explosive hazards, such as a damaged CRT face or bulging capacitor
- Mechanical hazards, such as loose or missing hardware

The guide consists of a series of steps presented as a checklist. Begin the checks with the power off, and the power cord disconnected.

Checklist:

1. Check exterior covers for damage (loose, broken, or sharp edges).
2. Power-off the computer. Disconnect the power cord.
3. Check the power cord for:
 - a. A third-wire ground connector in good condition. Use a meter to measure third-wire ground continuity for 0.1 ohm or less between the external ground pin and frame ground.
 - b. The power cord should be the appropriate type as specified in the parts listings.
 - c. Insulation must not be frayed or worn.
4. Remove the cover.
5. Check for any obvious alterations. Use good judgment as to the safety of any alterations.
6. Check inside the unit for any obvious hazards, such as metal filings, contamination, water or other liquids, or signs of fire or smoke damage.
7. Check for worn, frayed, or pinched cables.
8. Check that the power-supply cover fasteners (screws or rivets) have not been removed or tampered with.

Handling electrostatic discharge-sensitive devices

Any computer part containing transistors or integrated circuits (ICs) should be considered sensitive to electrostatic discharge (ESD). ESD damage can occur when there is a difference in charge between objects. Protect against ESD damage by equalizing the charge so that the computer, the part, the work mat, and the person handling the part are all at the same charge.

Notes:

1. Use product-specific ESD procedures when they exceed the requirements noted here.
2. Make sure that the ESD protective devices you use have been certified (ISO 9000) as fully effective.

When handling ESD-sensitive parts:

- Keep the parts in protective packages until they are inserted into the product.
- Avoid contact with other people while handling the part.
- Wear a grounded wrist strap against your skin to eliminate static on your body.
- Prevent the part from touching your clothing. Most clothing is insulative and retains a charge even when you are wearing a wrist strap.
- Use the black side of a grounded work mat to provide a static-free work surface. The mat is especially useful when handling ESD-sensitive devices.
- Select a grounding system, such as those listed below, to provide protection that meets the specific service requirement.

Note: The use of a grounding system is desirable but not required to protect against ESD damage.

- Attach the ESD ground clip to any frame ground, ground braid, or green-wire ground.
- Use an ESD common ground or reference point when working on a double-insulated or battery-operated system. You can use coax or connector-outside shells on these systems.
- Use the round ground-prong of the AC plug on AC-operated computers.

Grounding requirements

Electrical grounding of the computer is required for operator safety and correct system function. Proper grounding of the electrical outlet can be verified by a certified electrician.

Safety notices

The CAUTION and DANGER safety notices in this section are provided in the language of English.



DANGER

Electrical current from power, telephone and communication cables is hazardous.

To avoid a shock hazard:

- **Do not connect or disconnect any cables or perform installation, maintenance, or reconfiguration of this product during an electrical storm.**
- **Connect all power cords to a properly wired and grounded electrical outlet.**
- **Connect any equipment that will be attached to this product to a properly wired outlet.**
- **When possible, use one hand only to connect or disconnect signal cables.**
- **Never turn on any equipment when there is evidence of fire, water, or structural damage.**
- **Disconnect the attached power cords, telecommunications cables, network cables, and modem cables before you open the device covers, unless instructed otherwise in the installation and configuration procedures.**

- **Connect and disconnect cables as described in the following table when installing, moving, or opening covers on this product or attached devices.**

To Connect	To Disconnect
<ol style="list-style-type: none"> 1. Turn everything OFF. 2. First, attach all cables to devices. 3. Attach signal cables to connectors. 4. Attach power cords to outlet. 5. Turn device ON. 	<ol style="list-style-type: none"> 1. Turn everything OFF. 2. First, remove power cords from outlets. 3. Remove signal cables from connectors. 4. Remove all cables from devices.



CAUTION:

When replacing the lithium battery, use only Part Number 45C1566 or an equivalent type battery recommended by the manufacturer. If your system has a module containing a lithium battery, replace it only with the same module type made by the same manufacturer. The battery contains lithium and can explode if not properly used, handled, or disposed of.

Do not:

- Throw into or immerse in water
- Heat to more than 100°C (212°F)
- Repair or disassemble

Dispose of the battery as required by local ordinances or regulations.



CAUTION:

When laser products (such as CD-ROMs, DVD-ROM drives, fiber optic devices, or transmitters) are installed, note the following:



- Do not remove the covers. Removing the covers of the laser product could result in exposure to hazardous laser radiation. There are no serviceable parts inside the device.
- Use of controls or adjustments or performance of procedures other than those specified herein might result in hazardous radiation exposure.



 **DANGER**

Some laser products contain an embedded Class 3A or Class 3B laser diode. Note the following: These diodes emit radiation when open. Do not stare into the beam, do not view directly with optical instruments, and avoid direct exposure to the beam.



		
≥18 kg (37 lbs)	≥32 kg (70.5 lbs)	≥55 kg (121.2 lbs)

CAUTION:
Use safe practices when lifting.



CAUTION:
The power control button on the device and the power switch on the power supply do not turn off the electrical current supplied to the device. The device also might have more than one power cord. To remove all electrical current from the device, ensure that all power cords are disconnected from the power source.

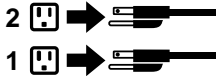

CAUTION:
Do not place any object weighing more than 82 kg (180 lbs.) on top of rack-mounted devices.



Chapter 2. Environment and electrical input

Environment

- Air temperature:
 - Operating: From 10°C (50°F) to 35°C (95°F)
 - Storage in original shipping package: From -40°C (-40°F) to 60°C (140°F)
 - Storage without package: From -10°C (14°F) to 60°C (140°F)
- Humidity:
 - Operating: 20%–80% (non-condensing)
 - Storage: 20%–90% (non-condensing)
- Altitude:
 - Operating: From -15.2 m (-50 ft) to 3048 m (10 000 ft)
 - Storage: From -15.2 m (-50 ft) to 10 668 m (35 000 ft)

Electrical input

Input voltage: From 100 V ac to 240 V ac

Input frequency: 50/60 Hz

Chapter 3. General Checkout

Attention: The drives in the computer you are servicing might have been rearranged or the drive startup sequence may have been changed. Be extremely careful during write operations such as copying, saving, or formatting. Data or programs can be overwritten if you select an incorrect drive.

General error messages appear if a problem or conflict is found by an application, the operating system, or both. For an explanation of these messages, refer to the information supplied with that software package.

Use the following procedure to help determine the cause of the problem:

1. Power-off the computer and all external devices.
2. Check all cables and power cords.
3. Set all display controls to the middle position.
4. Power-on all external devices.
5. Power-on the computer.
 - Look for error codes displayed.
 - Look for readable instructions or a main menu on the display.
If you did not receive the correct response, proceed to step 6.
If you did receive the correct response, proceed to step 7.
6. If one of the following happens, follow the instruction given:
 - If the computer displays a POST error, go to “POST error codes”.
 - If the computer hangs and no error is displayed, continue at step 7.
7. If the test stops and you cannot continue, replace the last device tested.

Chapter 4. Using the Setup Utility program

The Setup Utility program is used to view and change the configuration settings of your computer. This section provides information about only the major configuration settings available in the program.

Note: The operating system settings might override some similar settings in the Setup Utility program.

Starting the Setup Utility program

To start the Setup Utility program, do the following:

1. Turn on or restart your computer.
2. Before Windows® starts up, repeatedly press and release the F1 key until the Setup Utility program opens. If a BIOS password has been set, the Setup Utility program will not open until you enter the correct password. For more information, see “Using BIOS passwords” on page 11.

Note: For some keyboards, you might need to press Fn+F1 to open the Setup Utility program.

To view and change the configuration settings, follow the instructions on the right side of the screen. The keys used to perform various tasks are displayed at the bottom of the screen.

Enabling or disabling a device

This section provides information about how to enable or disable user access to hardware devices (such as USB connectors or storage drives).

To enable or disable a device, do the following:

1. Start the Setup Utility program. See “Starting the Setup Utility program” on page 11.
2. Select **Devices**.
3. Select the device you want to enable or disable and press Enter.
4. Select the desired setting and press Enter.
5. Exit the Setup Utility program. See “Exiting the Setup Utility program” on page 13.

Enabling or disabling the Automatic Power On features

If you enable the Automatic Power On features, your computer will start up automatically.

To enable or disable the Automatic Power On features, do the following:

1. Start the Setup Utility program. See “Starting the Setup Utility program” on page 11.
2. Select **Power → Automatic Power On** and press Enter.
3. Select the feature you want to enable or disable and press Enter.
4. Select the desired setting and press Enter.
5. Exit the Setup Utility program. See “Exiting the Setup Utility program” on page 13.

Using BIOS passwords

By using the Setup Utility program, you can set passwords to prevent unauthorized access to your computer and data.

You do not have to set all passwords to use your computer. However, using passwords improves computer security.

Setup Utility program password types

The following types of passwords are available:

- **Power-on password**
When a power-on password is set, you are prompted to enter a valid password each time the computer is turned on. The computer cannot be used until the valid password is entered.
- **Administrator password**
Setting an administrator password deters unauthorized users from changing configuration settings. If you are responsible for maintaining the configuration settings of several computers, you might want to set an administrator password.
When an administrator password is set, you are prompted to enter a valid password each time you try to access the Setup Utility program. The Setup Utility program cannot be accessed until a valid password is entered.
If both the power-on password and administrator password are set, you can enter either password. However, you must use your administrator password to change all configuration settings.

Password considerations

A password can be any combination of up to 64 alphabetic and numeric characters. For security reasons, it is recommended to use a strong password that cannot be easily compromised.

Note: The Setup Utility program passwords are not case sensitive.

To set a strong password, consider the following guidelines:

- Have at least eight characters in length
- Contain at least one alphabetic character and one numeric character
- Not be your name or your user name
- Not be a common word or a common name
- Be significantly different from your previous passwords

Setting, changing, and deleting a password

To set, change, or delete a password, do the following:

1. Start the Setup Utility program. See “Starting the Setup Utility program” on page 11.
2. Select **Security**.
3. Depending on the password type, select **Set Power-On Password** or **Set Administrator Password**, and press Enter.
4. Follow the instructions on the right side of the screen to set, change, or delete a password.

Note: A password can be any combination of up to 64 alphabetic and numeric characters. For more information, see “Password considerations” on page 12.

5. Exit the Setup Utility program. See “Exiting the Setup Utility program” on page 13.

Selecting a startup device

If your computer does not start up from a device as expected, you can choose to change the startup device sequence permanently or select a temporary startup device.

Changing the startup device sequence permanently

To change the startup device sequence permanently, do the following:

1. Depending on the type of the storage device, do one of the following:
 - If the storage device is internal, go to step 2.
 - If the storage device is a disc, ensure that your computer is on or turn on the computer. Then, insert the disc into the optical drive.
 - If the storage device is an external device other than a disc, connect the storage device to the computer.
2. Start the Setup Utility program. See “Starting the Setup Utility program” on page 11.
3. Select **Startup**.
4. Follow the instructions on the right side of the screen to change the startup device sequence.
5. Exit the Setup Utility program. See “Exiting the Setup Utility program” on page 13.

Selecting a temporary startup device

Note: Not all discs and storage drives are bootable.

To select a temporary startup device, do the following:

1. Depending on the type of the storage device, do one of the following:
 - If the storage device is internal, go to step 2.
 - If the storage device is a disc, ensure that your computer is on or turn on the computer. Then, insert the disc into the optical drive.
 - If the storage device is an external device other than a disc, connect the storage device to the computer.
2. Turn on or restart the computer. Before Windows starts up, repeatedly press and release the F12 key until Startup Device Menu is displayed.

Note: For some keyboards, you might need to press Fn+F12 to display Startup Device Menu.

3. Select the desired storage device and press Enter. The computer will start up from the device you select.

If you want to select a permanent startup device, select **Enter Setup** on Startup Device Menu and press Enter to start the Setup Utility program. For more information about how to select a permanent startup device, see “Changing the startup device sequence permanently” on page 13.

Exiting the Setup Utility program

To exit the Setup Utility program, do one of the following:

- If you want to save the new settings, press the F10 key. Then, select **Yes** in the window displayed and press Enter.

Note: For some keyboards, you might need to press Fn+F10 to exit the Setup Utility program.

- If you do not want to save the new settings, select **Exit → Discard Changes and Exit** and press Enter. Then, select **Yes** in the window displayed and press Enter.

Chapter 5. Symptom-to-FRU Index

The Symptom-to-FRU index lists error symptoms and possible causes. The most likely cause is listed first. Always begin with Chapter 4, “General Checkout,” on page 11. This index can also be used to help you decide which FRUs to have available when servicing a computer. If you are unable to correct the problem using this index, go to “Undetermined problems” on page 20.

Notes:

- If you have both an error message and an incorrect audio response, diagnose the error message first.
- If you cannot run the diagnostic tests or you get a diagnostic error code when running a test but did receive a POST error message, diagnose the POST error message first.
- If you did not receive any error messages, look for a description of your error symptom in the first part of this index.

Hard disk drive boot error

A hard disk drive boot error can be caused by the following.

Error	FRU/Action
The startup drive is not included in the boot sequence configuration.	Check the configuration and ensure the startup drive is in the boot sequence.
No operating system is installed on the boot drive.	Install an operating system on the boot drive.
The boot sector on the startup drive is corrupted.	The drive must be formatted. Do the following: <ol style="list-style-type: none">1. Attempt to back up the data on the failing hard disk drive.2. Use the operating system to format the hard disk drive.
The drive is defective.	Replace the hard disk drive.

Power Supply Problems

Follow these procedures if you suspect there is a power supply problem.

Check/Verify	FRU/Action
Check that the following are properly installed: <ul style="list-style-type: none">• Power Cord• On/Off Switch connector• System Board Power Supply connectors• Microprocessor connections	Reseat connectors
Check the power cord.	Power Cord
Check the power-on switch.	Power-on Switch

POST error codes

Each time you turn the computer on, it performs a series of tests to check that the system is operating correctly and that certain options are set. This series of tests is called the *Power-On Self-Test*, or *POST*. POST does the following:

- Checks some basic motherboard operations
- Checks that the memory is working correctly
- Starts video operations
- Verifies that the boot drive is working

POST Error Message	Description/Action
Keyboard error	Cannot initialize the keyboard. Make sure the keyboard is properly connected to the computer and that no keys are held pressed during POST. To purposely configure the computer without a keyboard, select Keyboardless operation in Startup and set the option to Enabled . The BIOS then ignores the missing keyboard during POST.
Reboot and Select proper Boot device or Insert Boot Media in selected Boot device	The BIOS was unable to find a suitable boot device. Make sure the boot drive is properly connected to the computer. Make sure you have bootable media in the boot device.

Undetermined problems

1. Power-off the computer.
2. Remove or disconnect the following components (if connected or installed) one at a time.
 - a. External devices (modem, printer, or mouse)
 - b. Extended video memory
 - c. External Cache
 - d. External Cache RAM
 - e. Hard disk drive
 - f. Disk drive
3. Power-on the computer to re-test the system.
4. Repeat steps 1 through 3 until you find the failing device or component.

If all devices and components have been removed and the problem continues, replace the system board.

Chapter 6. Hardware locations

This section provides information about the locations of your computer hardware.

Note: The computer hardware might look slightly different from the illustrations.

Front view and rear view

Attention: Be careful not to block any air vents on the computer. Blocked air vents can cause overheating.

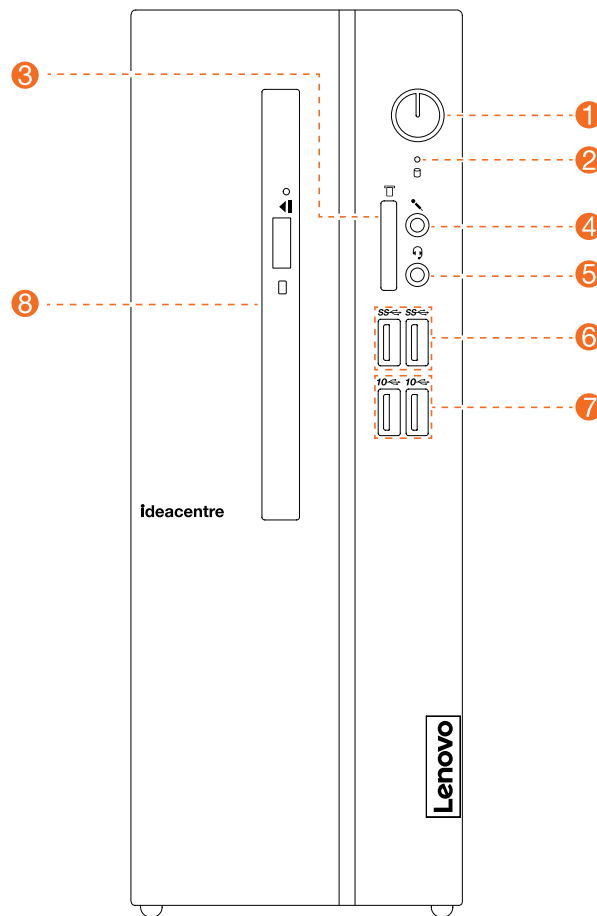

Figure 1. Front view and rear view

1 Power button	2 Hard disk drive indicator
3 Memory card reader (selected models only)	4 Microphone connector
5 Combo audio jack	6 USB 3.0 connectors (2)
7 USB 3.1 Gen 2 connectors (2)	8 Optical Drive (selected models only)

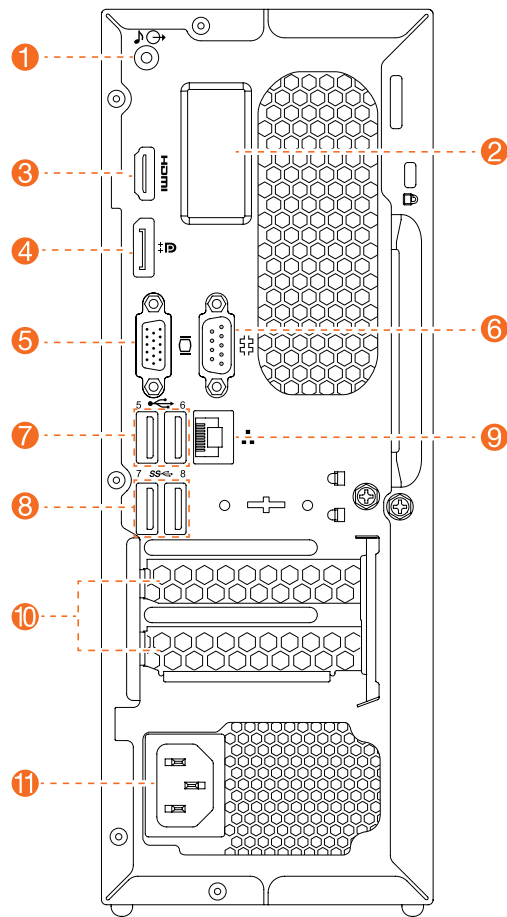

Figure 2. Rear view

1 Audio connector	2 Wi-Fi antenna (selected models only)
3 HDMI-out connector	4 DisplayPort® connector
5 On-board VGA connector	6 Serial connector
7 USB 2.0 connectors (2)	8 USB 3.0 connectors (2)
9 Ethernet connector	10 Expansion card slots
11 Power connector	

Major FRUs and CRUs

Note: Depending on your computer model, some of the following components might not be available.

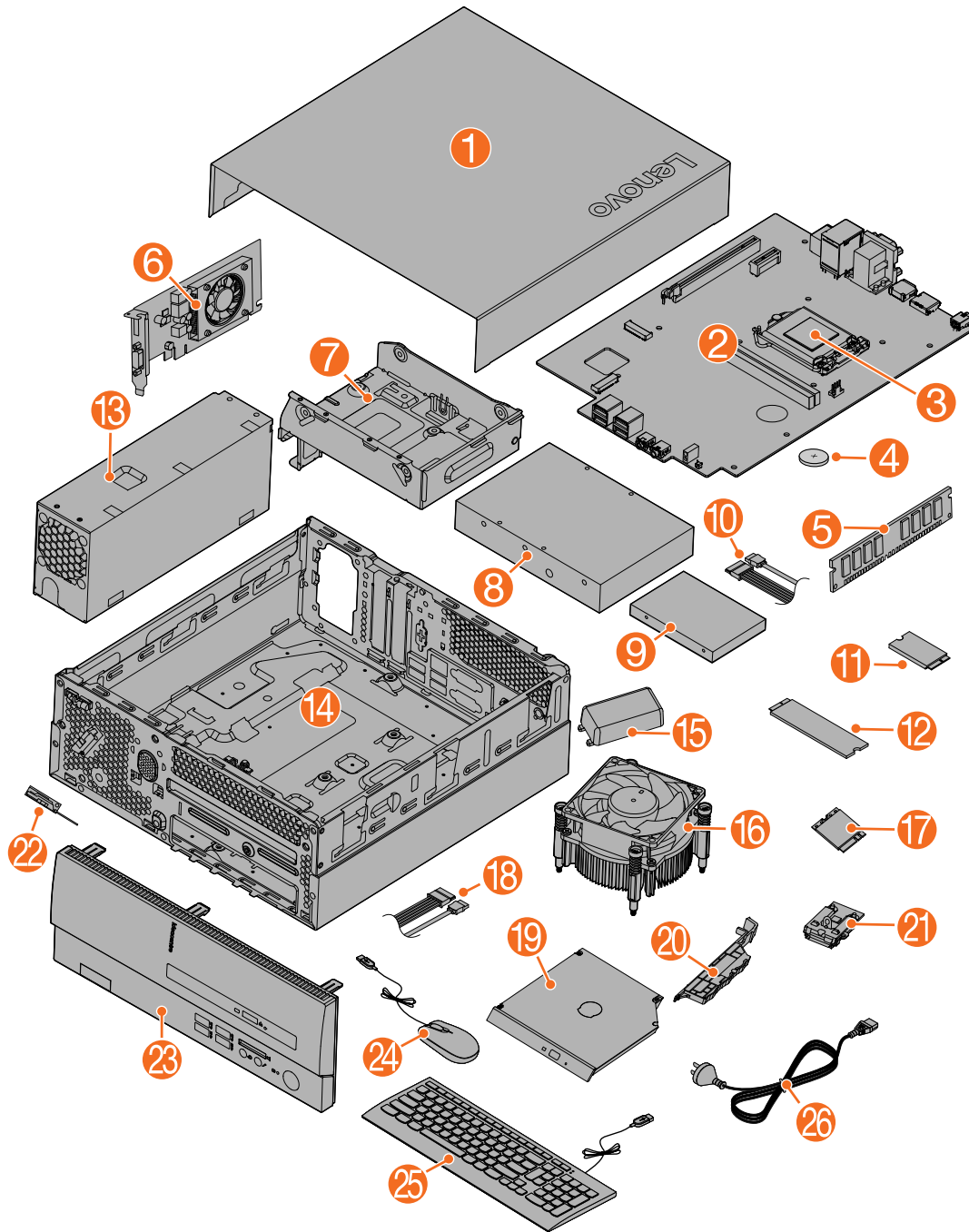

Figure 3. Major FRUs and CRUs

The following table lists the major FRUs shown in the illustration above and identifies which FRUs are also self-service CRUs or optional-service CRUs.

Notes:

- Self-service CRUs: Parts to be installed or replaced by customer themselves.
- Optional-service CRUs: Parts can be installed or replaced by customers or technicians under certain terms of the applicable warranty service type for your country or region.
- Non-CRUs: Parts must be installed or replaced only by trained service technicians

No.	Description	Self-service CRU	Optional-service CRU
1	Side cover	Yes	No
2	Motherboard	No	No
3	CPU	No	No
4	Coin-cell battery	No	Yes
5	Memory module	Yes	No
6	Graphic card	Yes	No
7	Hard disk drive bracket	Yes	No
8	Hard disk drive 3.5"	Yes	No
9	Hard disk drive 2.5"	Yes	No
10	Hard disk drive cable	No	No
11	M.2 SSD 2242 card	Yes	No
12	M.2 SSD 2280 card	Yes	No
13	Power supply	No	Yes
14	Chassis bracket	No	No
15	Wi-Fi ethernet cover	No	No
16	Heat-sink module	No	No
17	Wi-Fi card	No	No
18	Optical drive cable	No	No
19	Optical drive	Yes	No
20	Front I/O bracket	No	No
21	Card reader	No	No
22	Wi-Fi Ethernet	No	No
23	Front cover	Yes	No
24	Mouse	Yes	No
25	Keyboard	Yes	No
26	Power cord	Yes	No

For detailed FRU information, such as the FRU part numbers and supported computer models, go to: <http://www.lenovo.com/serviceparts-lookup>

Parts on the main boards

The main boards include the I/O board and the system board.

Parts on the system board

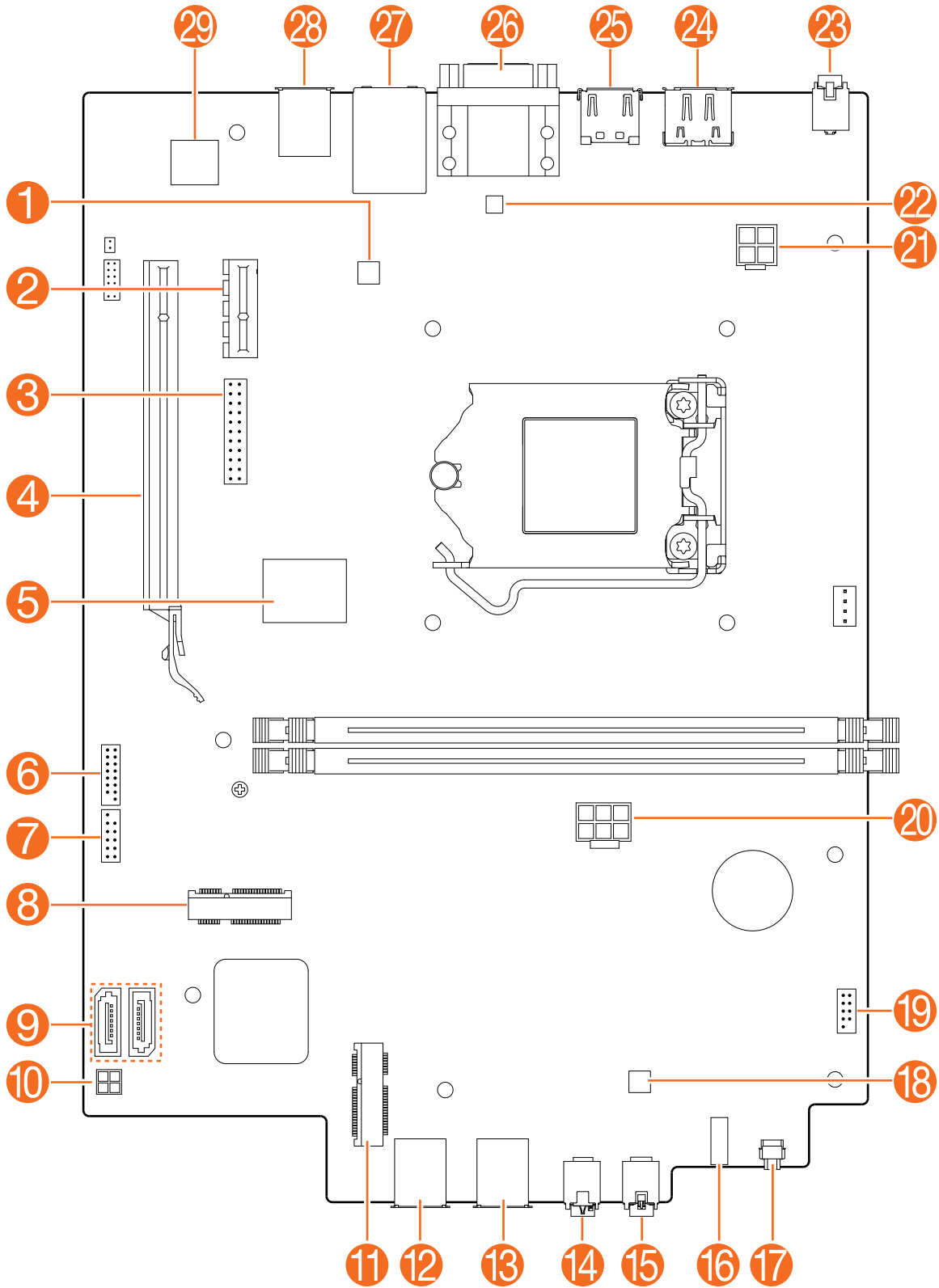

Figure 4. Parts on the system board

1 LAN Chip	2 PCI express X 1 adapter slot
3 LPT Header	4 PCI express X 16 adapter slot
5 PCH	6 Serial (COM2) header
7 USB 2.0 header	8 M.2 2230 drive slot (Wi-Fi card connector)
9 SATA connectors (2)	10 SATA power connector
11 M.2 2280 solid-state drive slot	12 USB 3.1 Gen 2 connectors (2)
13 USB 3.0 connectors (2)	14 Headphone connector
15 Microphone connector	16 Hard disk indicator
17 Power switch LED	18 Audio Codec
19 Front panel connector	20 6-pin power connector
21 4-pin power connector	22 DP2 VGA bridge
23 Audio connector	24 HDMI-out connector
25 DisplayPort connector	26 VGA connector and Serial connector
27 USB 2.0 (2) and Ethernet connectors	28 USB 3.0 connectors (2)
28 SIO	

Chapter 7. Installing or replacing hardware

This chapter contains the following topics:

- “Handling static-sensitive devices” on page 25
- “Installing or replacing hardware” on page 25

Handling static-sensitive devices

Do not open the static-protective package containing the new part until the defective part has been removed and you are ready to install the new part. Static electricity, although harmless to you, can seriously damage computer components and parts.

When you handle parts and other computer components, take these precautions to avoid static-electricity damage:

- Limit your movement. Movement can cause static electricity to build up around you.
- Always handle parts and other computer components carefully. Handle PCI/PCI-Express cards, memory modules, system boards, and microprocessors by the edges. Never touch any exposed circuitry.
- Prevent others from touching the parts and other computer components.
- Touch the static-protective package containing the part to a metal expansion-slot cover or other unpainted metal surface on the computer for at least two seconds. This reduces static electricity from the package and your body before you install or replace a new part.
- When possible, remove the new part from the static-protective package, and install it directly in the computer without setting the part down. When this is not possible, place the static-protective package that the part came in on a smooth, level surface and place the part on the package.
- Do not place the part on the computer cover or other metal surface.

Installing or replacing hardware

This section provides instructions on how to install or replace hardware for your computer. You can expand the capabilities of your computer and maintain your computer by installing or replacing hardware.

Attention: Do not open your computer or attempt any repair before reading and understanding the Chapter 1 “Read this first: Important safety information” on page 1.

Notes:

- Some of the hardware parts in this section are optional.
- Use computer parts provided only by Lenovo.
- When installing or replacing an option, use the appropriate instructions in this section along with the instructions that come with the option.
- In most areas of the world, Lenovo requires the return of the defective CRU. Information about this will come with the CRU or will come a few days after the CRU arrives.

Removing the computer covers

Attention: Do not open your computer or attempt any repair before reading and understanding the Chapter 1 “Read this first: Important safety information” on page 1.

- Turn off the computer and wait 3 to 5 minutes to let it cool down before removing the cover.

- For this procedure, it helps to lay the computer on a flat, stable surface.

CAUTION:



Before you open the computer covers, turn off the computer and wait several minutes until the computer is cool.

To remove the computer covers, do the following:

1. Remove all media from the drives and turn off all connected devices and the computer. Then, disconnect all power cords from electrical outlets and all cables that are connected to the computer.
2. Unlock all locking devices that secure the computer covers.
3. Remove the screw that secures the cover, slide the computer cover outward as shown.

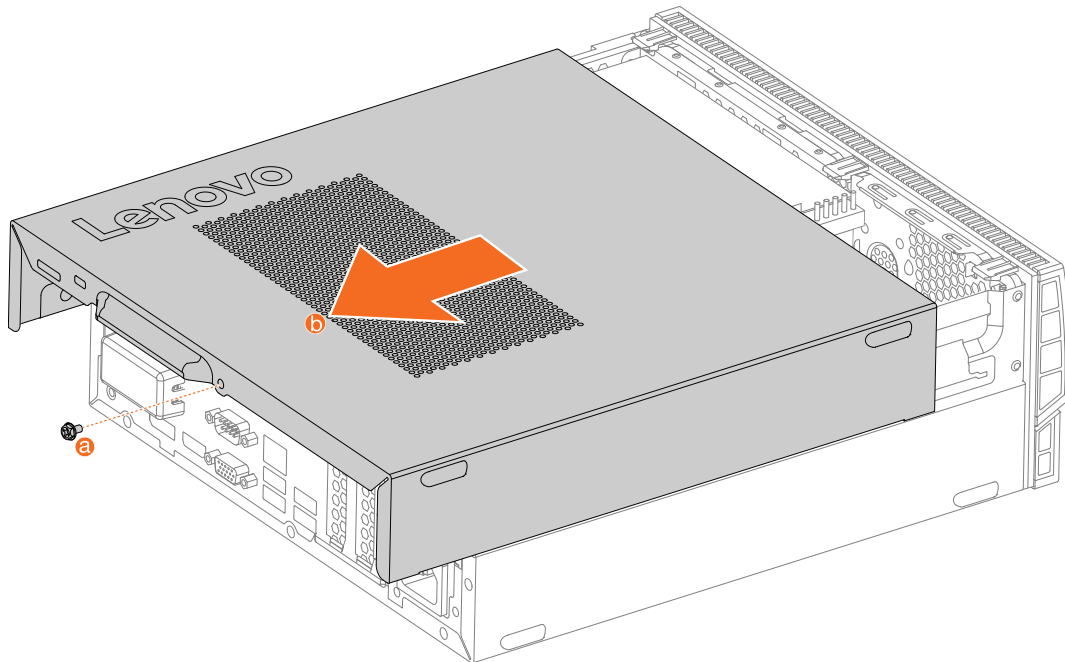

Figure 5. Removing the side cover

Removing the front bezel

Attention: Do not open your computer or attempt any repair before reading and understanding the Chapter 1 “Read this first: Important safety information” on page 1.

To replace the I/O board shield, do the following:

1. Remove all media from the drives and turn off all connected devices and the computer. Then, disconnect all power cords from electrical outlets and all cables that are connected to the computer.
2. Remove the computer side cover. See “Removing the computer covers” on page 25.
3. Remove the front bezel by releasing the three plastic tabs as shown.

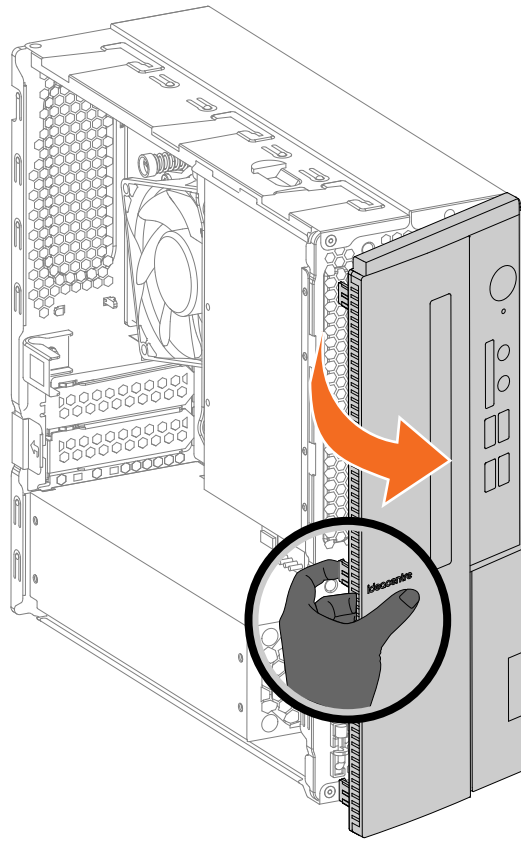

Figure 6. Removing the front bezel

What to do next:

- To work with another piece of hardware, go to the appropriate section.
- To complete the installation or replacement, go to “Completing the parts replacement” on page 38.

Replacing an optical drive

Attention: Do not open your computer or attempt any repair before reading and understanding the Chapter 1 “Read this first: Important safety information” on page 1.

To replace the I/O board, do the following:

1. Remove all media from the drives and turn off all connected devices and the computer. Then, disconnect all power cords from electrical outlets and all cables that are connected to the computer.
2. Remove the computer covers. See “Removing the computer covers” on page 25.
3. Remove the front bezel. See “Removing the front bezel” on page 26.
4. Disconnect the data and power cables from the rear of the optical drive.
5. Press the release button and push the optical drive straight out of the front of the chassis.
6. Detach the bracket from the optical drive as shown.

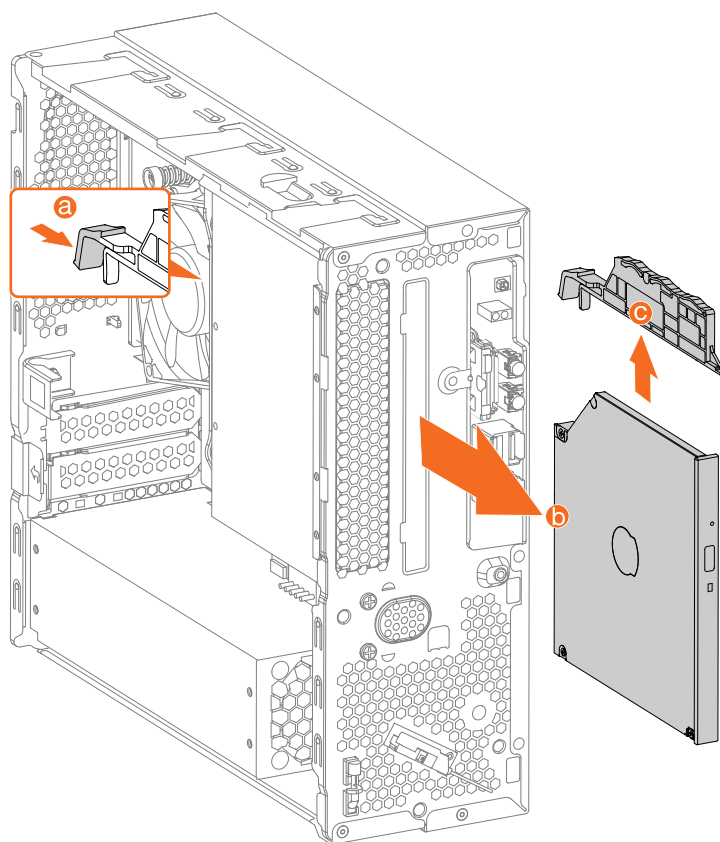

Figure 7. Removing the optical drive

7. Install the new optical drive.
8. Route all the cables that you disconnected from the failing optical drive, and then connect the cables to the new optical drive. See “Parts on the main boards” on page 21.

What to do next:

- To work with another piece of hardware, go to the appropriate section.
- To complete the installation or replacement, go to “Completing the parts replacement” on page 38.

Replacing a hard disk drive

Attention: Do not open your computer or attempt any repair before reading and understanding the Chapter 1 “Read this first: Important safety information” on page 1.

To replace the storage drive, refer to one of the following topics:

- “Replacing the 3.5-inch hard disk drive” on page 28
- “Replacing the 2.5-inch hard disk drive” on page 30

Replacing the 3.5-inch hard disk drive

To replace the 3.5-inch storage drive, do the following:

1. Remove all media from the drives and turn off all connected devices and the computer. Then, disconnect all power cords from electrical outlets and all cables that are connected to the computer.
2. Remove the computer covers. See “Removing the computer covers” on page 25.
3. Remove the 3.5-inch hard disk drive as shown.

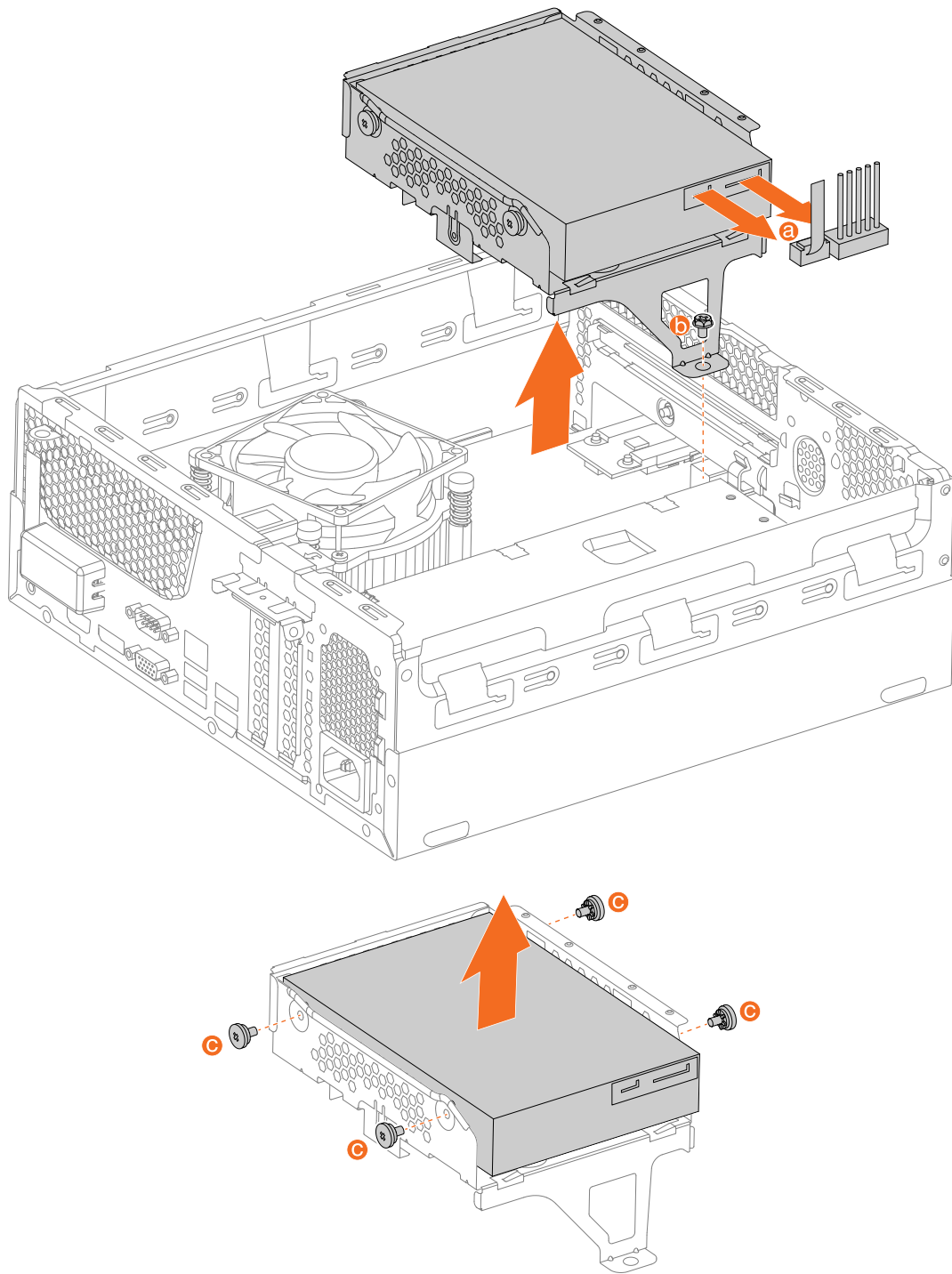

Figure 8. Removing the 3.5-inch hard disk drive

4. Install the new 3.5-inch hard disk drive.

What to do next:

- To work with another piece of hardware, go to the appropriate section.
- To complete the installation or replacement, go to “Completing the parts replacement” on page 38.

Replacing the 2.5-inch hard disk drive

To replace the 2.5-inch storage drive, do the following:

1. Remove all media from the drives and turn off all connected devices and the computer. Then, disconnect all power cords from electrical outlets and all cables that are connected to the computer.
2. Remove the computer covers. See “Removing the computer covers” on page 25.
3. Remove the 2.5-inch hard disk drive as shown.

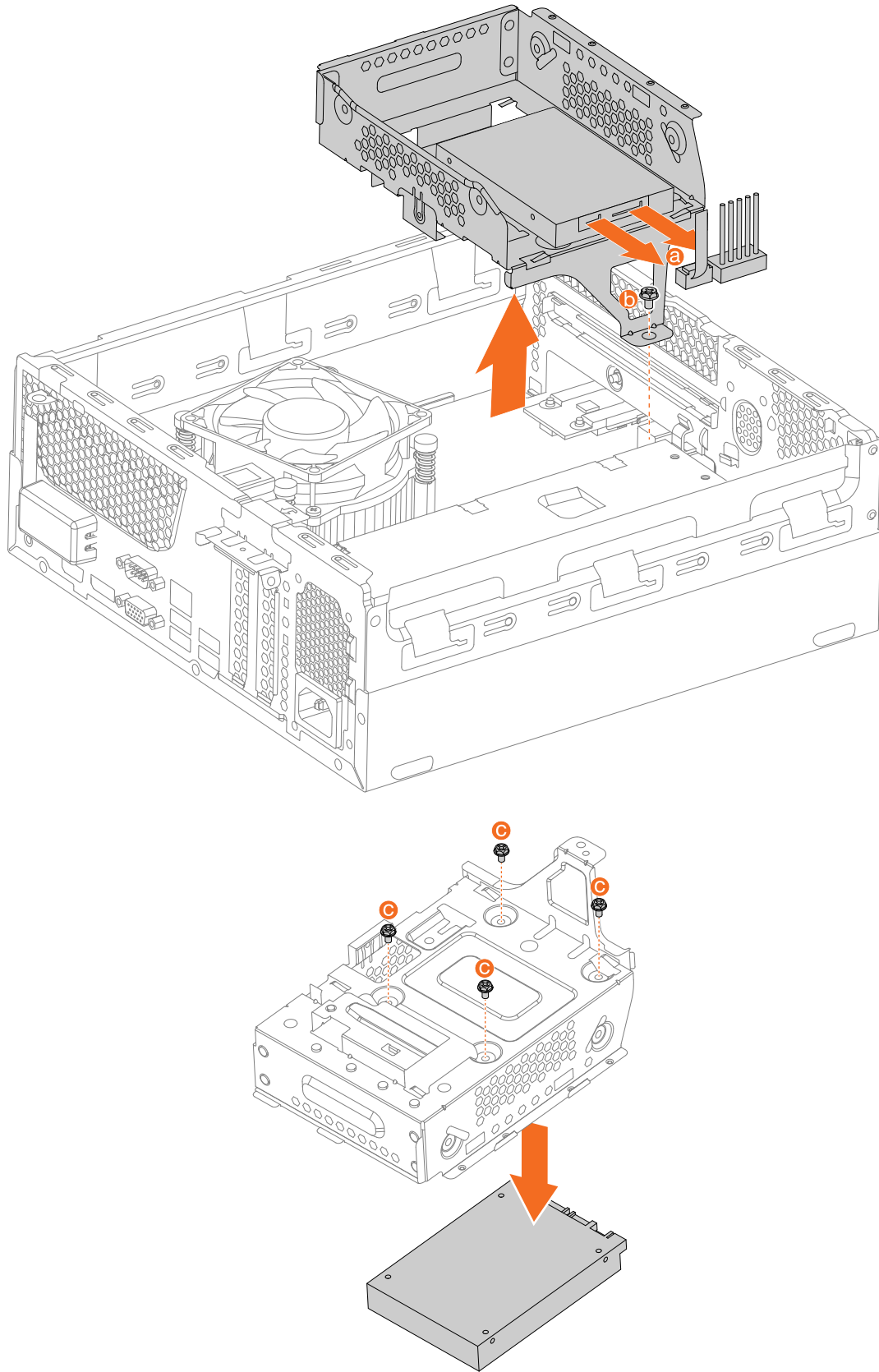

Figure 9. Removing the 2.5-inch hard disk drive

4. Install the new 2.5-inch hard disk drive.

What to do next:

- To work with another piece of hardware, go to the appropriate section.
- To complete the installation or replacement, go to “Completing the parts replacement” on page 38.

Replacing a graphics card

Attention: Do not open your computer or attempt any repair before reading and understanding the Chapter 1 “Read this first: Important safety information” on page 1.

To replace the power button board, do the following:

1. Remove all media from the drives and turn off all connected devices and the computer. Then, disconnect all power cords from electrical outlets and all cables that are connected to the computer.
2. Remove the computer covers. See “Removing the computer covers” on page 25.
3. Open the drive bay as shown.
4. Open the metal tab that secure the graphic card to the chassis.
5. Push the locking pin on the motherboard to release the graphic card.
6. Lift the graphic card straight up to remove it.

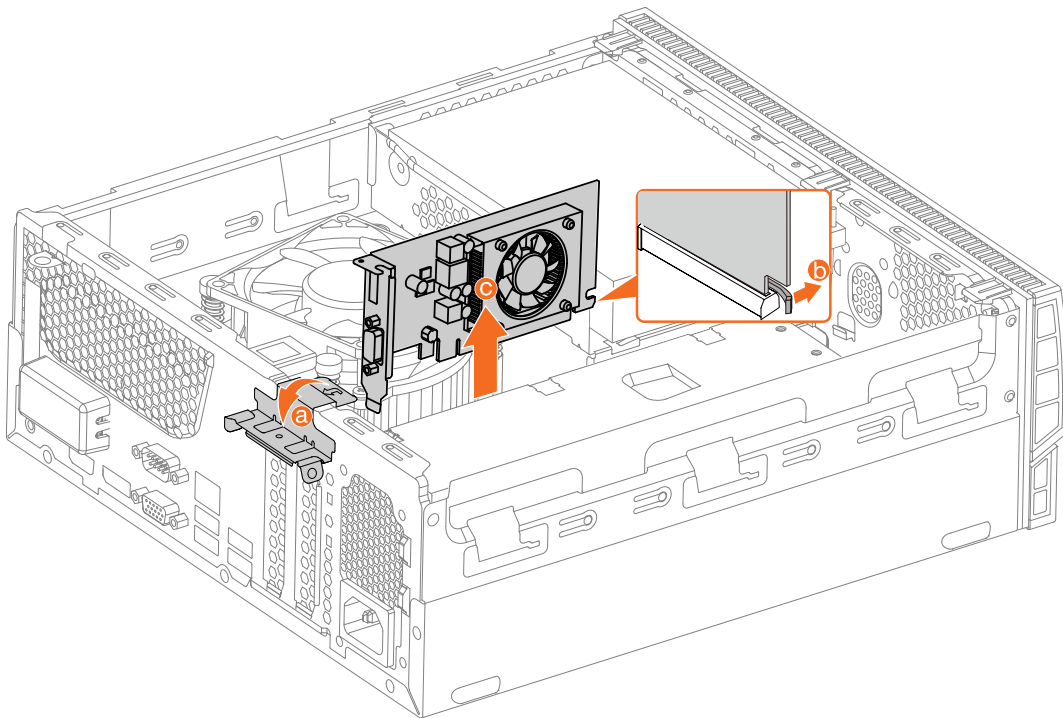

Figure 10. Removing the graphics card

7. Install the new graphics card.

What to do next:

- To work with another piece of hardware, go to the appropriate section.
- To complete the installation or replacement, go to “Completing the parts replacement” on page 38.

Replacing the memory module

Attention: Do not open your computer or attempt any repair before reading and understanding the Chapter 1 “Read this first: Important safety information” on page 1.

To replace the memory module, do the following:

1. Remove all media from the drives and turn off all connected devices and the computer. Then, disconnect all power cords from electrical outlets and all cables that are connected to the computer.
2. Remove the computer covers. See “Removing the computer covers” on page 25.
3. Remove the memory module as shown.

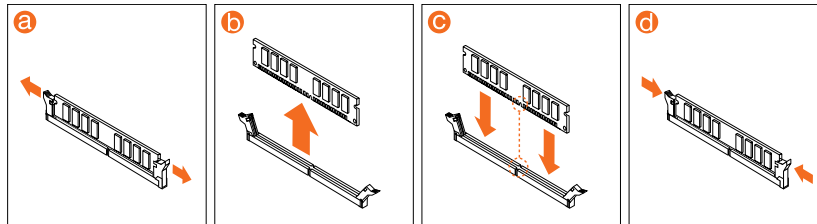

Figure 11. Removing the memory module

4. Install the new memory module.

What to do next:

- To work with another piece of hardware, go to the appropriate section.
- To complete the installation or replacement, go to “Completing the parts replacement” on page 38.

Replacing the heat sinks

Attention: Do not open your computer or attempt any repair before reading and understanding the Chapter 1 “Read this first: Important safety information” on page 1.

CAUTION:



The heat sinks might be very hot. Before you open the computer covers, turn off the computer and wait several minutes until the computer is cool.

To replace the heat sinks, do the following:

1. Remove all media from the drives and turn off all connected devices and the computer. Then, disconnect all power cords from electrical outlets and all cables that are connected to the computer.
2. Remove the computer covers. See “Removing the computer covers” on page 25.
3. Disconnect the fan power cable from the connector on the motherboard.
4. Remove the heat sink as shown.

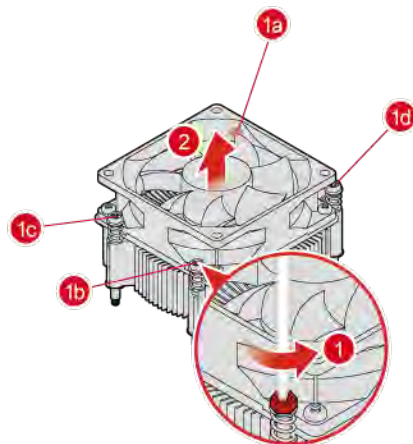

Figure 12. Removing the heat sink

What to do next:

- To work with another piece of hardware, go to the appropriate section.
- To complete the installation or replacement, go to “Completing the parts replacement” on page 38.

Replacing the Wi-Fi card

Attention: Do not open your computer or attempt any repair before reading and understanding the Chapter 1 “Read this first: Important safety information” on page 1.

To replace the Wi-Fi card, do the following:

1. Remove all media from the drives and turn off all connected devices and the computer. Then, disconnect all power cords from electrical outlets and all cables that are connected to the computer.
2. Remove the computer covers. See “Removing the computer covers” on page 25.
3. Disconnect the Wi-Fi antenna cables from the Wi-Fi card.
4. Remove the Wi-Fi card as shown.

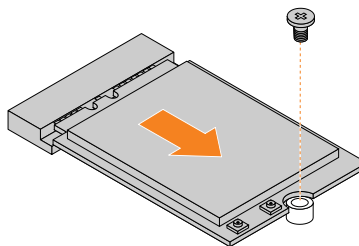

Figure 13. Removing the Wi-Fi card

5. Install the new Wi-Fi card.
6. Connect the Wi-Fi antenna cables to the new Wi-Fi card.

What to do next:

- To work with another piece of hardware, go to the appropriate section.
- To complete the installation or replacement, go to “Completing the parts replacement” on page 38.

Replacing the card reader

Attention: Do not open your computer or attempt any repair before reading and understanding the Chapter 1 “Read this first: Important safety information” on page 1.

To replace the card reader, do the following:

1. Remove all media from the drives and turn off all connected devices and the computer. Then, disconnect all power cords from electrical outlets and all cables that are connected to the computer.
2. Remove the computer covers. See “Removing the computer covers” on page 25.
3. Remove the card reader as shown.

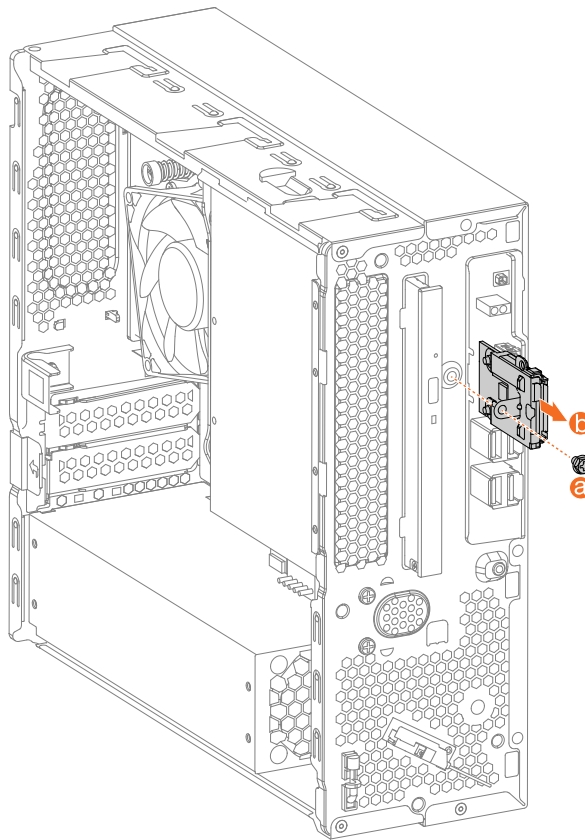

Figure 14. Removing the card reader

4. Install the new card reader.

What to do next:

- To work with another piece of hardware, go to the appropriate section.
- To complete the installation or replacement, go to “Completing the parts replacement” on page 38.

Replacing the coin-cell battery

Attention: Do not open your computer or attempt any repair before reading and understanding the Chapter 1 “Read this first: Important safety information” on page 1.

Your computer has a special type of memory that maintains the date, time, and settings for built-in features, such as parallel-connector assignments (configuration). A coin-cell battery keeps this information active when you turn off the computer.

The coin-cell battery normally requires no charging or maintenance throughout its life; however, no coin-cell battery lasts forever. If the coin-cell battery fails, the date, time, and configuration information (including passwords) are lost. An error message is displayed when you turn on the computer.

To replace the coin-cell battery, do the following:

1. Remove all media from the drives and turn off all connected devices and the computer. Then, disconnect all power cords from electrical outlets and all cables that are connected to the computer.
2. Remove the computer covers. See “Removing the computer covers” on page 25.
3. Remove the front bezel. See “Removing the front bezel” on page 26.
4. Remove the memory module. See “Replacing the memory module” on page 33.
5. Remove the heat-sink assembly. See “Replacing the heat sinks” on page 33.
6. Remove the graphic card. See “Replacing a graphics card” on page 32.
7. Remove the Wi-Fi card. See “Replacing the Wi-Fi card” on page 34
8. Remove the coin-cell battery as shown.

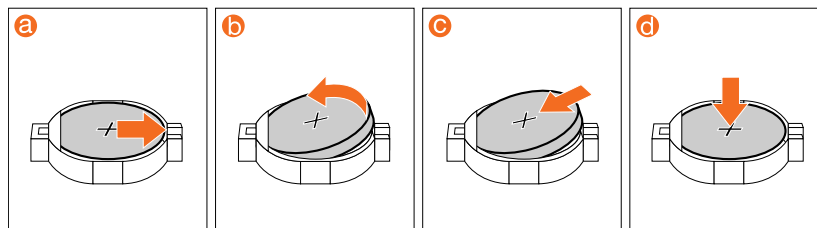

Figure 15. Removing the coin-cell battery

9. Install the new coin-cell battery.
10. Reinstall the system board.
11. Turn on the computer and all connected devices.

Note: When the computer is turned on for the first time after replacing the coin-cell battery, an error message might be displayed. This is normal after replacing the coin-cell battery.

12. Use the Setup Utility program to set the date, time, and any passwords. See Chapter 4 “Using the Setup Utility program” on page 11.

Replacing the microprocessor

Attention: Do not open your computer or attempt any repair before reading and understanding the Chapter 1 “Read this first: Important safety information” on page 1.

CAUTION:



The heat sinks might be very hot. Before you open the computer covers, turn off the computer and wait several minutes until the computer is cool.

To replace the microprocessor, do the following:

1. Remove all media from the drives and turn off all connected devices and the computer. Then, disconnect all power cords from electrical outlets and all cables that are connected to the computer.
2. Remove the computer covers. See “Removing the computer covers” on page 25.
3. Remove the front bezel. See “Removing the front bezel” on page 26.
4. Remove the heat-sink assembly. See “Replacing the heat sinks” on page 33.
5. Remove the microprocessor as shown.

Notes:

- Your microprocessor and socket might look different from the one illustrated.
- Touch only the edges of the microprocessor. Do not touch the gold contacts on the bottom.
- Do not touch the thermal grease while handling the microprocessor.
- Do not drop anything onto the microprocessor socket while it is exposed. The socket pins must be kept as clean as possible.

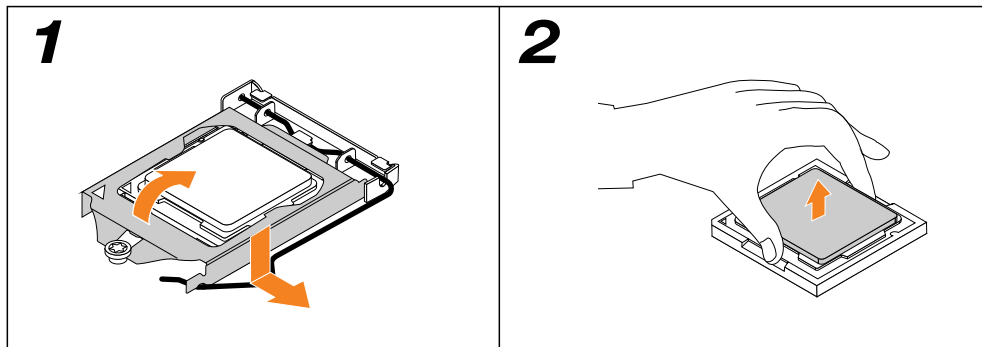

Figure 16. Removing the microprocessor

6. Install the new microprocessor.
7. Reinstall the system board.

What to do next:

- To work with another piece of hardware, go to the appropriate section.
- To complete the installation or replacement, go to “Completing the parts replacement” on page 38.

Replacing the system board

Attention: Do not open your computer or attempt any repair before reading and understanding the Chapter 1 “Read this first: Important safety information” on page 1.

To replace the system board shield and storage drive board shield, do the following:

1. Remove all media from the drives and turn off all connected devices and the computer. Then, disconnect all power cords from electrical outlets and all cables that are connected to the computer.
2. Remove the computer covers. See “Removing the computer covers” on page 25.
3. Remove the front bezel. See “Removing the front bezel” on page 26.
4. Remove the memory module. See “Replacing the memory module” on page 33.

5. Remove the heat-sink assembly. See “Replacing the heat sinks” on page 33.
6. Remove the graphic card. See “Replacing a graphics card” on page 32.
7. Remove the Wi-Fi card. See “Replacing the Wi-Fi card” on page 34.
8. Remove the coin-cell battery. See “Replacing the coin-cell battery” on page 36.
9. Remove the microprocessor. See “Replacing the microprocessor” on page 36
10. Disconnect the all cables from the connectors on system board.
11. Remove the storage drive board shield and the system board shield as shown.

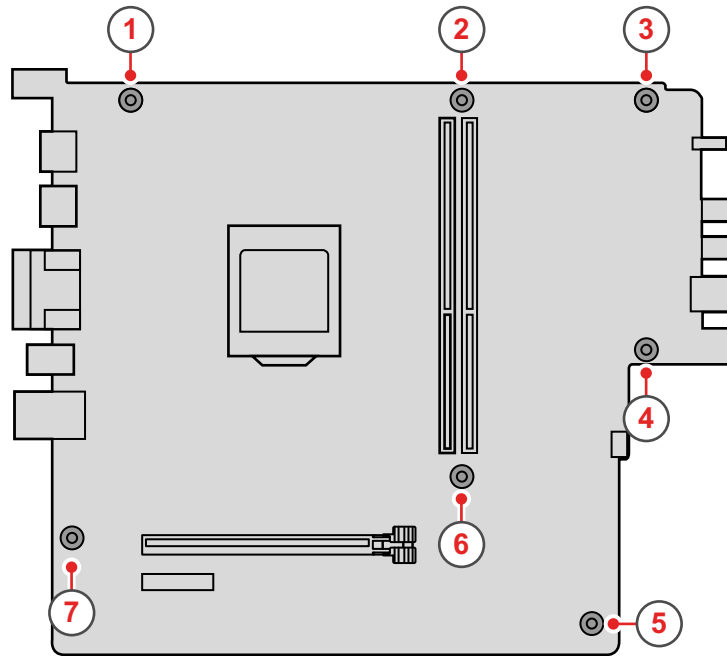

Figure 17. Removing the system board

12. Install the new system board

What to do next:

- To work with another piece of hardware, go to the appropriate section.
- To complete the installation or replacement, go to “Completing the parts replacement” on page 38.

Completing the parts replacement

To reinstall the computer covers and reconnect cables to your computer, do the following:

1. Ensure that all components have been reassembled correctly and that no tools or loose screws are left inside your computer. See Chapter 6 “Hardware locations” on page 17 for the locations of various components in your computer.
2. Ensure that the cables are routed correctly before reinstalling the computer cover. Keep cables clear of the hinges and sides of the computer chassis to avoid interference with reinstalling the computer cover.
3. Reinstall the front bezel.
4. Reinstall the side cover.
5. If a locking device is available, use it to lock the computer.
6. Reconnect the external cables and power cords to the corresponding connectors on the computer.
7. Depending on the parts you installed or replaced, you might need to confirm the updated information. See Chapter 4 “Using the Setup Utility program” on page 11.

8. If a newly installed hardware component does not work normally, update the device driver.

Chapter 8. Additional Service Information

This chapter provides additional information that the service representative might find helpful.

Power management

Power management reduces the power consumption of certain components of the computer such as the system power supply, processor, hard disk drives, and some monitors.

Advanced configuration and power interface (ACPI) BIOS

As this computer has an ACPI BIOS system, the operating system is allowed to control the power management features of the computer and the settings for Advanced Power Management (APM) BIOS mode is ignored. Not all operating systems support ACPI BIOS mode.

Automatic Power-On features

The Automatic Power-On features within the Power Management menu allow you to enable and disable features that turn on the computer automatically.

- Wake Up on Alarm: You can specify a date and time at which the computer will be turned on automatically. This can be either a single event , a daily event or a weekly event.
- Wake Up on LAN: This feature allows LAN adapter card to wake the System.

Trademarks

The following terms are trademarks of Lenovo in the United States, other countries, or both:

- ideacentre
- Lenovo
- The Lenovo logo

Windows is a trademark of the Microsoft group of companies.

Other company, product, or service names may be trademarks or service marks of others.

