

Lenovo YOGA 530

YOGA 530-14IKB

YOGA 530-14ARR

Hardware Maintenance Manual

Lenovo[™]

Note:

- Before using this information and the product it supports, be sure to read the general information under “Notices” on page 85.

First Edition (March 2018)

© Copyright Lenovo 2018. All rights reserved.

LIMITED AND RESTRICTED RIGHTS NOTICE: If data or software is delivered pursuant a General Services Administration “GSA” contract, use, reproduction, or disclosure is subject to restrictions set forth in Contract No. GS-35F-05925.

© 2018 Lenovo

Contents

About this manual	iv	1040 DIMM	41
Safety information	1	1050 SSD card	42
General safety	2	1060 Speakers	44
Electrical safety	3	1070 Fan and heat sink assembly	45
Safety inspection guide	5	1080 Upper case	47
Handling devices that are sensitive to electrostatic discharge	6	1090 System board	50
Grounding requirements	6	1100 I/O board	52
Safety notices: multilingual translations	7	1110 LCD unit	53
Laser compliance statement	14	1120 MIC board, sensor board, camera and EDP cable	57
Important service information	16	Locations	59
Strategy for replacing FRUs	16	Front view and right-side view	59
Strategy for replacing a hard disk drive	17	Bottom and Left-side view	60
Important notice for replacing a system board	17	Parts list	61
Important information about replacing RoHS compliant FRUs	18	Overall	62
		LCD FRUs	79
		Miscellaneous parts	81
		AC power adapters	81
		Screws	84
General checkout	19	Notices	85
What to do first	20	Trademarks	86
Power system checkout	21		
Checking the AC adapter	21		
Checking operational charging	22		
Checking the battery pack	22		
Related service information	23		
Restoring the factory contents by using Push-button reset	23		
Restore of factory default	23		
Passwords	24		
Power-on password	24		
Hard-disk password	24		
Administrator password	24		
Power management	25		
Putting the computer to sleep or shutting it down	25		
Putting your computer to sleep	25		
Shutting down the computer	26		
Lenovo YOGA 530-14IKB/ YOGA 530-14ARR	27		
Specifications	27		
Status indicators	29		
Hotkeys	30		
FRU replacement notices	31		
Screw notices	31		
Removing and replacing an FRU	32		
1010 Base cover	33		
1020 Battery pack	37		
1030 PCI Express Mini Card for wireless LAN	39		

About this manual

This manual contains service and reference information for the following Lenovo product:

Lenovo YOGA 530-14IKB/YOGA 530-14ARR

The illustrations and descriptions in this manual may differ from the actual product. Please refer to the actual product.

The manual is divided into the following sections:

- The common sections provide general information, guidelines, and safety information required for servicing computers.
- The product-specific section includes service, reference, and product-specific parts information.

Important:

This manual is intended only for trained servicers who are familiar with Lenovo products. Use this manual to troubleshoot problems effectively.

Before servicing a Lenovo product, make sure to read all the information under “Safety information” on page 1 and “Important service information” on page 16.

Safety information

This chapter presents the following safety information that you need to get familiar with before you service a Lenovo YOGA 530-14IKB/YOGA 530-14ARR computer:

- “General safety” on page 2
- “Electrical safety” on page 3
- “Safety inspection guide” on page 5
- “Handling devices that are sensitive to electrostatic discharge” on page 6
- “Grounding requirements” on page 6
- “Safety notices: multilingual translations” on page 7
- “Laser compliance statement” on page 14

General safety

Follow these rules below to ensure general safety:

- Observe a good housekeeping in the area where the machines are put during and after the maintenance.
- When lifting any heavy object:
 1. Make sure that you can stand safely without slipping.
 2. Distribute the weight of the object equally between your feet.
 3. Use a slow lifting force. Never move suddenly or twist when you attempt to lift it.
 4. Lift it by standing or pushing up with your leg muscles; this action could avoid the strain from the muscles in your back. Do not attempt to lift any object that weighs more than 16 kg (35 lb) or that you think is too heavy for you.
- Do not perform any action that causes hazards to the customer, or that makes the machine unsafe.
- Before you start the machine, make sure that other service representatives and the customer are not in a hazardous position.
- Please remove covers and other parts in a safe place, away from all personnel, while you are servicing the machine.
- Keep your toolcase away from walk areas so that other people will not trip over it.
- Do not wear loose clothing that can be trapped in the moving parts of the machine. Make sure that your sleeves are fastened or rolled up above your elbows. If your hair is long, fasten it.
- Insert the ends of your necktie or scarf inside clothing or fasten it with the nonconductive clip, about 8 centimeters (3 inches) from the end.
- Do not wear jewelry, chains, metal-frame eyeglasses, or metal fasteners for your clothing.

Attention: Metal objects are good electrical conductors.
- Wear safety glasses when you are hammering, drilling, soldering, cutting wire, attaching springs, using solvents, or working in any other conditions that may be hazardous to your eyes.
- After service, reinstall all safety shields, guards, labels, and ground wires. Replace any safety device that is worn or defective.
- Reinstall all covers correctly before returning the machine to the customer.
- Fan louvers on the machine help to prevent the overheating of internal components. Do not obstruct fan louvers or cover them with labels or stickers.

Electrical safety

Observe the following rules when working on electrical equipments.

Important:

Use only approved tools and test equipments. Some hand tools have handles covered with a soft material that does not insulate you when working with live electrical currents.

Many customers have rubber floor mats near their machines that contain small conductive fibers to decrease electrostatic discharges. Do not use such kind of mat to protect yourself from electrical shock.

- Find the room emergency power-off (EPO) switch, disconnecting switch or electrical outlet. If an electrical accident occurs, you can then operate the switch or unplug the power cord quickly.
- Do not work alone under hazardous conditions or near the equipment that has hazardous voltages.
- Disconnect all power before:
 - Performing a mechanical inspection
 - Working near power supplies
 - Removing or installing main units
- Before you start to work on the machine, unplug the power cord. If you cannot unplug it, ask the customer to power-off the wall box that supplies power to the machine, and to lock the wall box in the off position.
- If you need to work on a machine that has exposed electrical circuits, observe the following precautions:
 - Ensure that another person, familiar with the power-off controls, is near you.

Attention: Another person must be there to switch off the power, if necessary.
 - Use only one hand when working with powered-on electrical equipment; keep the other hand in your pocket or behind your back.

Attention: An electrical shock can occur only when there is a complete circuit. By observing the above rule, you may prevent a current from passing through your body.
 - When using testers, set the controls correctly and use the approved probe leads and accessories for that tester.
 - Stand on suitable rubber mats (obtained locally, if necessary) to insulate you from grounds such as metal floor strips and machine frames.

Observe the special safety precautions when you work with very high voltages; instructions for these precautions are in the safety sections of maintenance information. Be extremely careful when you measure the high voltages.

- Regularly inspect and maintain your electrical hand tools for safe operational condition.
- Do not use worn or broken tools and testers.
- Never assume that power has been disconnected from a circuit. First, check it to make sure that it has been powered off.

- Always look carefully for possible hazards in your work area. Examples of these hazards are moist floors, nongrounded power extension cables, power surges, and missing safety grounds.
- Do not touch live electrical circuits with the reflective surface of a plastic dental mirror. The surface is conductive; such touching can cause personal injury and machine damage.
- Do not service the following parts with the power on when they are removed from their normal operating places in a machine:
 - Power supply units
 - Pumps
 - Blowers and fans
 - Motor generatorsand similar units. (This practice ensures correct grounding of the units.)
- If an electrical accident occurs:
 - Caution: do not become a victim yourself.
 - Switch off the power.
 - Send the victim to get medical aid.

Safety inspection guide

The purpose of this inspection guide is to assist you in identifying potential unsafe conditions. As each machine was designed and built, required safety items were installed to protect users and service personnel from injury. This guide addresses only those items. You should use good judgment to identify potential safety hazards according to the attachment of non-Lenovo features or options not covered by this inspection guide.

If any unsafe conditions are present, you must determine how serious the apparent hazard could be and whether you can continue without first correcting the problem.

Consider these conditions and the safety hazards they present:

- Electrical hazards, especially primary power (primary voltage on the frame can cause serious or fatal electrical shock)
- Explosive hazards, such as a damaged CRT face or a bulging capacitor
- Mechanical hazards, such as loose or missing hardware

To determine whether there are any potential unsafe conditions, use the following checklist at the beginning of every service task. Begin the checks with the power off, and the power cord disconnected.

Checklist:

1. Check exterior covers for damage (loose, broken, or sharp edges).
2. Turn off the computer. Disconnect the power cord.
3. Check the power cord for:
 - a. A third-wire ground connector in good condition. Use a meter to measure third-wire ground continuity for 0.1 ohm or less between the external ground pin and the frame ground.
 - b. The power cord should be the type specified in the parts list.
 - c. Insulation must not be frayed or worn.
4. Check for cracked or bulging batteries.
5. Remove the cover.
6. Check for any obvious non-Lenovo alterations. Use good judgment as to the safety of any non-Lenovo alterations.
7. Check inside the unit for any obvious unsafe conditions, such as metal filings, contamination, water or other liquids, or signs of fire or smoke damage.
8. Check for worn, frayed, or pinched cables.
9. Check that the power-supply cover fasteners (screws or rivets) have not been removed or tampered with.

Handling devices that are sensitive to electrostatic discharge

Any computer part containing transistors or integrated circuits (ICs) should be considered sensitive to electrostatic discharge (ESD). ESD damage can occur when there is a difference in charge between objects. Protect against ESD damage by equalizing the charge so that the machine, the part, the work mat, and the person handling the part are all at the same charge.

Notes:

1. Use product-specific ESD procedures when they exceed the requirements noted here.
2. Make sure that the ESD protective devices you use have been certified (ISO 9000) as fully effective.

When handling ESD-sensitive parts:

- Keep the parts in protective packages until they are inserted into the product.
- Avoid contact with other people.
- Wear a grounded wrist strap against your skin to eliminate static on your body.
- Prevent the part from touching your clothing. Most clothing is insulative and retains a charge even when you are wearing a wrist strap.
- Use the black side of a grounded work mat to provide a static-free work surface. The mat is especially useful when handling ESD-sensitive devices.
- Select a grounding system, such as those listed below, to provide protection that meets the specific service requirement.

Note:

The use of a grounding system to guard against ESD damage is desirable but not necessary.

- Attach the ESD ground clip to any frame ground, ground braid, or green-wire ground.
- When working on a double-insulated or battery-operated system, use an ESD common ground or reference point. You can use coax or connector-outside shells on these systems.
- Use the round ground prong of the ac plug on ac-operated computers.

Grounding requirements

Electrical grounding of the computer is required for operator safety and correct system function. Proper grounding of the electrical outlet can be verified by a certified electrician.

Safety notices: multilingual translations

The safety notices in this section are provided in English, French, German, Hebrew, Italian, Japanese, and Spanish.

Safety notice 1

Before the computer is powered on after FRU replacement, make sure all screws, springs, and other small parts are in place and are not left loose inside the computer. Verify this by shaking the computer and listening for rattling sounds. Metallic parts or metal flakes can cause electrical shorts.

Avant de remettre l'ordinateur sous tension après remplacement d'une unité en clientèle, vérifiez que tous les ressorts, vis et autres pièces sont bien en place et bien fixées. Pour ce faire, secouez l'unité et assurez-vous qu'aucun bruit suspect ne se produit. Des pièces métalliques ou des copeaux de métal pourraient causer un court-circuit.

Bevor nach einem FRU-Austausch der Computer wieder angeschlossen wird, muß sichergestellt werden, daß keine Schrauben, Federn oder andere Kleinteile fehlen oder im Gehäuse vergessen wurden. Der Computer muß geschüttelt und auf Klappergeräusche geprüft werden. Metallteile oder-splitter können Kurzschlüsse erzeugen.

לפני הפעלת המחשב לאחר החלפת FRU יש לוודא שכל הברגים, הקפיצים, וחלקים קטנים אחרים נמצאים במקומם ואינם חופשיים לזוז בתוך המחשב. כדי לוודא זאת, יש לטלטל את המחשב ולהקשיב לגילוי קולות שקשוק. חלקי או שבבי מתכת עלולים לגרום לקצרים חשמליים.

Prima di accendere l'elaboratore dopo che é stata effettuata la sostituzione di una FRU, accertarsi che tutte le viti, le molle e tutte le altri parti di piccole dimensioni siano nella corretta posizione e non siano sparse all'interno dell'elaboratore. Verificare ciò scuotendo l'elaboratore e prestando attenzione ad eventuali rumori; eventuali parti o pezzetti metallici possono provocare cortocircuiti pericolosi.

FRUの交換後、コンピュータの電源を入れる前に、ねじ、バネ、その他の小さな部品がすべて正しい位置にあり、またコンピュータの内部で緩んでいないことを確認してください。これを確認するには、コンピュータを振って、カチャカチャと音がしないか確かめます。金属部品や金属破片はショートの原因になることがあります。

Antes de encender el sistema despues de sustituir una FRU, compruebe que todos los tornillos, muelles y demás piezas pequeñas se encuentran en su sitio y no se encuentran sueltas dentro del sistema. Compruébelo agitando el sistema y escuchando los posibles ruidos que provocarían. Las piezas metálicas pueden causar cortocircuitos eléctricos.

Safety notice 2

DANGER

Some standby batteries contain a small amount of nickel and cadmium. Do not disassemble a standby battery, recharge it, throw it into fire or water, or short-circuit it. Dispose of the battery as required by local ordinances or regulations. Use only the battery in the appropriate parts listing. Use of an incorrect battery can result in ignition or explosion of the battery.

Certaines batteries de secours contiennent du nickel et du cadmium. Ne les démontez pas, ne les rechargez pas, ne les exposez ni au feu ni à l'eau. Ne les mettez pas en court-circuit. Pour les mettre au rebut, conformez-vous à la réglementation en vigueur. Lorsque vous remplacez la pile de sauvegarde ou celle de l'horloge temps réel, veillez à n'utiliser que les modèles cités dans la liste de pièces détachées adéquate. Une batterie ou une pile inappropriée risque de prendre feu ou d'exploser.

Die Bereitschaftsbatterie, die sich unter dem Diskettenlaufwerk befindet, kann geringe Mengen Nickel und Cadmium enthalten. Sie darf nicht zerlegt, wiederaufgeladen, kurzgeschlossen, oder Feuer oder Wasser ausgesetzt werden. Bei der Entsorgung die örtlichen Bestimmungen für Sondermüll beachten. Beim Ersetzen der Bereitschafts- oder Systembatterie nur Batterien des Typs verwenden, der in der Ersatzteilliste aufgeführt ist. Der Einsatz falscher Batterien kann zu Entzündung oder Explosion führen.

סוללות המתנה מסוימות מכילות כמויות קטנות של ניקל וקדמיום. אין לפרק סוללות המתנה, לטעון אותה מחדש, להשליך אותה לאש או למים או לקצר אותה. יש לשלוק את הסוללה בנדרש על ידי התקנות והחוקים המקומיים. יש להשתמש רק בסוללה המומיפה ברשימת החלקים המתאימה. שימוש בסוללה לא מתאימה עלול לגרום להצתה או התפוצצות של הסוללה.

Alcune batterie di riserva contengono una piccola quantità di nichel e cadmio. Non smontarle, ricaricarle, gettarle nel fuoco o nell'acqua né cortocircuitarle. Smaltirle secondo la normativa in vigore (DPR 915/82, successive disposizioni e disposizioni locali). Quando si sostituisce la batteria dell'RTC (real time clock) o la batteria di supporto, utilizzare soltanto i tipi inseriti nell'appropriato Catalogo parti. L'impiego di una batteria non adatta potrebbe determinare l'incendio o l'esplosione della batteria stessa.

予備バッテリーの中には少量のニッケルとカドミウムが含まれているものがあります。したがって、予備バッテリーの分解、再充電、火または水の中への投棄、またはショートさせることは決して行わないでください。バッテリーを廃棄する場合は地方自治体の条例に従ってください。適切なパーツ・リストにあるバッテリーだけを请使用してください。誤ったバッテリーを使用すると、バッテリーが発火したり、爆発したりすることがあります。

Algunas baterías de reserva contienen una pequeña cantidad de níquel y cadmio. No las desmonte, ni recargue, ni las eche al fuego o al agua ni las cortocircuite. Deséchelas tal como dispone la normativa local. Utilice sólo baterías que se encuentren en la lista de piezas. La utilización de una batería no apropiada puede provocar la ignición o explosión de la misma.

Safety notice 3**⚠ DANGER**

The battery pack contains small amounts of nickel. Do not disassemble it, throw it into fire or water, or short-circuit it. Dispose of the battery pack as required by local ordinances or regulations. Use only the battery in the appropriate parts listing when replacing the battery pack. Use of an incorrect battery can result in ignition or explosion of the battery.

La batterie contient du nickel. Ne la démontez pas, ne l'exposez ni au feu ni à l'eau. Ne la mettez pas en court-circuit. Pour la mettre au rebut, conformez-vous à la réglementation en vigueur. Lorsque vous remplacez la batterie, veuillez à n'utiliser que les modèles cités dans la liste de pièces détachées adéquate. En effet, une batterie inappropriée risque de prendre feu ou d'exploser.

Akkus enthalten geringe Mengen von Nickel. Sie dürfen nicht zerlegt, wiederaufgeladen, kurzgeschlossen, oder Feuer oder Wasser ausgesetzt werden. Bei der Entsorgung die örtlichen Bestimmungen für Sondermüll beachten. Beim Ersetzen der Batterie nur Batterien des Typs verwenden, der in der Ersatzteilliste aufgeführt ist. Der Einsatz falscher Batterien kann zu Entzündung oder Explosion führen.

מאזו הסוללה מכיל כמות קטנה של ניקל וקדמיום. אין לפרק את מאזו הסוללה, להשליך אותו לאש או למים או לקצר אותו. יש לסלק את מאזו הסוללה הסוללה כנדרש על ידי התקנות החוקיים המקומיים. יש להשתמש רק בסוללה המובנית ברשימת החלקים המתאימה בזמן החלפת מאזו הסוללה. שימוש בסוללה לא מתאימה עלול לגרום להצתה או התפוצצות של הסוללה.

La batteria contiene piccole quantità di nichel. Non smontarla, gettarla nel fuoco o nell'acqua né cortocircuitarla. Smaltirla secondo la normativa in vigore (DPR 915/82, successive disposizioni e disposizioni locali). Quando si sostituisce la batteria, utilizzare soltanto i tipi inseriti nell'appropriato Catalogo parti. L'impiego di una batteria non adatta potrebbe determinare l'incendio o l'esplosione della batteria stessa.

バッテリー・パックには少量のニッケルが含まれています。バッテリー・パックを分解したり、火または水の中に投げ込んだり、ショートさせないでください。バッテリー・パックの廃棄にあたっては、地方自治体の条例または規則に従ってください。バッテリー・パックを交換するときは、適切なパーツ・リストにあるバッテリーだけを使用してください。誤ったバッテリーを使用すると、バッテリーが発火したり、爆発したりすることがあります。

Las baterías contienen pequeñas cantidades de níquel. No las desmonte, ni recargue, ni las eche al fuego o al agua ni las cortocircuite. Deséchelas tal como dispone la normativa local. Utilice sólo baterías que se encuentren en la lista de piezas al sustituir la batería. La utilización de una batería no apropiada puede provocar la ignición o explosión de la misma.

Safety notice 4

DANGER

The lithium battery can cause a fire, an explosion, or a severe burn. Do not recharge it, remove its polarized connector, disassemble it, heat it above 100°C (212°F), incinerate it, or expose its cell contents to water. Dispose of the battery as required by local ordinances or regulations. Use only the battery in the appropriate parts listing. Use of an incorrect battery can result in ignition or explosion of the battery.

La pile de sauvegarde contient du lithium. Elle présente des risques d'incendie, d'explosion ou de brûlures graves. Ne la rechargez pas, ne retirez pas son connecteur polarisé et ne la démontez pas. Ne l'exposez pas à une température supérieure à 100°C, ne la faites pas brûler et n'en exposez pas le contenu à l'eau. Mettez la pile au rebut conformément à la réglementation en vigueur. Une pile inappropriée risque de prendre feu ou d'exploser.

Die Systematterie ist eine Lithiumatterie. Sie kann sich entzünden, explodieren oder schwere Verbrennungen hervorrufen. Batterien dieses Typs dürfen nicht aufgeladen, zerlegt, über 100 C erhitzt oder verbrannt werden. Auch darf ihr Inhalt nicht mit Wasser in Verbindung gebracht oder der zur richtigen Polung angebrachte Verbindungsstecker entfernt werden. Bei der Entsorgung die örtlichen Bestimmungen für Sondermüll beachten. Beim Ersetzen der Batterie nur Batterien des Typs verwenden, der in der Ersatzteilliste aufgeführt ist. Der Einsatz falscher Batterien kann zu Entzündung oder Explosion führen.

סוללת הליתיום עלולה לגרום לשריפה, להתפוצצות או לפגיעות קשות. אין לטעון אותה מחדש, לנטות את המחובר המקוטב שלה, למרק אותה או לחמם אותה לטמפרטורה העולה על 100 מעלות צלזיוס. אין לשרוף את הסוללה ואין לחשוף את תוכן התא למים. יש לנטות את הסוללה כנדרש במקנות ובחוקים המקומיים. יש להשתמש רק בסוללה המומייעה ברשימת החלקים המתאימים. שימוש בסוללה אחרת עלול לגרום לטכנת שריפה או התפוצצות.

La batteria di supporto e una batteria al litio e puo incendiarsi, esplodere o procurare gravi ustioni. Evitare di ricaricarla, smontarne il connettore polarizzato, smontarla, riscaldarla ad una temperatura superiore ai 100 gradi centigradi, incendiarla o gettarla in acqua. Smaltirla secondo la normativa in vigore (DPR 915/82, successive disposizioni e disposizioni locali). L'impiego di una batteria non adatta potrebbe determinare l'incendio o l'esplosione della batteria stessa.

リチウム・バッテリーは、火災、爆発、または重症のやけどを引き起こすことがあります。バックアップ・バッテリーの充電、その極性コネクターの取り外し、バッテリー本体の分解、100°C (212°F) 以上への加熱、焼却、電池の中身を水に浸すことはしないでください。バッテリーを廃棄する場合は地方自治体の条例に従ってください。適切なパーツ・リストにあるバッテリーだけを使用してください。誤ったバッテリーを使用すると、バッテリーが発火したり、爆発したりすることがあります。

La batería de repuesto es una batería de litio y puede provocar incendios, explosiones o quemaduras graves. No la recargue, ni quite el conector polarizado, ni la desmonte, ni caliente por encima de los 100°C (212°F), ni la incinerar ni exponga el contenido de sus celdas al agua. Deséchela tal como dispone la normativa local.

Safety notice 5

If the LCD breaks and the fluid from inside the LCD gets into your eyes or on your hands, immediately wash the affected areas with water for at least for 15 minutes. Seek medical care if any symptoms caused by the fluid are present after washing.

Si le panneau d'affichage à cristaux liquides se brise et que vous recevez dans les yeux ou sur les mains une partie du fluide, rincez-les abondamment pendant au moins quinze minutes. Consultez un médecin si des symptômes persistent après le lavage.

Die Leuchtstoffröhre im LCD-Bildschirm enthält Quecksilber. Bei der Entsorgung die örtlichen Bestimmungen für Sondermüll beachten. Der LCD-Bildschirm besteht aus Glas und kann zerbrechen, wenn er unsachgemäß behandelt wird oder der Computer auf den Boden fällt. Wenn der Bildschirm beschädigt ist und die darin befindliche Flüssigkeit in Kontakt mit Haut und Augen gerät, sollten die betroffenen Stellen mindestens 15 Minuten mit Wasser abgespült und bei Beschwerden anschließend ein Arzt aufgesucht werden.

אם מסך הנביש הנוזלי (LCD) נשבר והנוזל מתוך המסך בא במגע עם עיניכם או ידיכם, שטפו את האזורים הנוגעים מיד במים במשך 15 דקות לפחות. פנו לקבלת עזרה רפואית אם תסמינים הנובעים מהמגע עם הנוזל נמשכים לאחר השטיפה.

Nel caso che caso l'LCD si dovesse rompere ed il liquido in esso contenuto entrasse in contatto con gli occhi o le mani, lavare immediatamente le parti interessate con acqua corrente per almeno 15 minuti; poi consultare un medico se i sintomi dovessero permanere.

LCD が破損し、LCD 中の液体が目に入ったり、手に触れたりした場合は、液体が触れた部分を少なくとも 15 分間洗い流してください。洗い流した後に、液体によって何らかの症状が現れた場合は、医師の治療を受けてください。

Si la LCD se rompe y el fluido de su interior entra en contacto con sus ojos o sus manos, lave inmediatamente las áreas afectadas con agua durante 15 minutos como mínimo. Obtenga atención medica si se presenta algún síntoma del fluido despues de lavarse.

Safety notice 6

DANGER

To avoid shock, do not remove the plastic cover that protects the lower part of the inverter card.

Afin d'éviter tout risque de choc électrique, ne retirez pas le cache en plastique protégeant la partie inférieure de la carte d'alimentation.

Aus Sicherheitsgründen die Kunststoffabdeckung, die den unteren Teil der Spannungswandlerplatine umgibt, nicht entfernen.

כדי למנוע התחשמלות, אין להסיר את מכסה הפלסטיק המגן על חלקו התחתון של הכרטיס ההפוך.

Per evitare scosse elettriche, non rimuovere la copertura in plastica che avvolge la parte inferiore della scheda invertitore.

感電を防ぐため、インバーター・カードの下部を保護しているプラスチック・カバーを外さないでください。

Para evitar descargas, no quite la cubierta de plástico que rodea la parte baja de la tarjeta invertida.

Safety notice 7

DANGER

Though the main batteries have low voltage, a shorted or grounded battery can produce enough current to burn personnel or combustible materials.

Bien que le voltage des batteries principales soit peu élevé, le court-circuit ou la mise à la masse d'une batterie peut produire suffisamment de courant pour brûler des matériaux combustibles ou causer des brûlures corporelles graves.

Obwohl Hauptbatterien eine niedrige Spannung haben, können sie doch bei Kurzschluß oder Erdung genug Strom abgeben, um brennbare Materialien zu entzünden oder Verletzungen bei Personen hervorzurufen.

אף שהסוללות הראשיות הן בעלות מתח נמוך, סוללה מקוצרת או מוארקות עלולה להפיק זרם מספיק לגרימת כוויות או להצתת חומרים דליקים.

Sebbene le batterie di alimentazione siano a basso voltaggio, una batteria in corto circuito o a massa può fornire corrente sufficiente da bruciare materiali combustibili o provocare ustioni ai tecnici di manutenzione.

メイン・バッテリーの電圧は低くても、ショートしたり、接地したバッテリーが、作業者にやけどを負わせたり、可燃物を燃やすだけの電流を発生させる場合があります。

Aunque las baterías principales tienen un voltaje bajo, una batería cortocircuitada o con contacto a tierra puede producir la corriente suficiente como para quemar material combustible o provocar quemaduras en el personal.

Safety notice 8** DANGER**

Before removing any FRU, turn off the computer, unplug all power cords from electrical outlets, remove the battery pack, and then disconnect any interconnecting cables.

Avant de retirer une unité remplaçable en clientèle, mettez le système hors tension, débranchez tous les cordons d'alimentation des socles de prise de courant, retirez la batterie et déconnectez tous les cordons d'interface.

Die Stromzufuhr muß abgeschaltet, alle Stromkabel aus der Steckdose gezogen, der Akku entfernt und alle Verbindungskabel abgenommen sein, bevor eine FRU entfernt wird.

לפני סילוק FRU כלשהו, יש לכבות את המחשב, לנתק את כל כבלי החשמל משקעי החשמל, להוציא את מארזי הסוללה, וזו לנתק כבלי חיבור אחרים אם יש כאלה.

Prima di rimuovere qualsiasi FRU, spegnere il sistema, scollegare dalle prese elettriche tutti i cavi di alimentazione, rimuovere la batteria e poi scollegare i cavi di interconnessione.

FRU を取り外す前に、**ThinkPad** の電源を切って、すべての電源コードをコンセントから外してください。次に、バッテリー・パックを外し、相互接続ケーブルを外してください。

Antes de quitar una FRU, apague el sistema, desenchufe todos los cables de las tomas de corriente eléctrica, quite la batería y, a continuación, desconecte cualquier cable de conexión entre dispositivos.

Laser compliance statement

Some models of Lenovo computer are equipped from the factory with an optical storage device such as a CD-ROM drive or a DVD-ROM drive. Such devices are also sold separately as options. If one of these drives is installed, it is certified in the U.S. to conform to the requirements of the Department of Health and Human Services 21 Code of Federal Regulations (DHHS 21 CFR) Subchapter J for Class 1 laser products. Elsewhere, the drive is certified to conform to the requirements of the International Electrotechnical Commission (IEC) 825 and CENELEC EN 60 825 for Class 1 laser products.

If a CD-ROM drive, a DVD-ROM drive, or another laser device is installed, note the following:

CAUTION

Use of controls or adjustments or performance of procedures other than those specified herein might result in hazardous radiation exposure.

O uso de controles, ajustes ou desempenho de procedimentos diferentes daqueles aqui especificados pode resultar em perigosa exposição à radiação.

凡未在这里指明的任何控制用法、调整、行为，都会导致严重后果。

Pour éviter tout risque d'exposition au rayon laser, respectez les consignes de réglage et d'utilisation des commandes, ainsi que les procédures décrites.

Werden Steuer- und Einstellelemente anders als hier festgesetzt verwendet, kann gefährliche Laserstrahlung auftreten.

Az itt előírt eljárásoktól, beállításoktól és vezérlésektől eltérni a lézersugárzás veszélye miatt kockázatos!

L'utilizzo di controlli, regolazioni o l'esecuzione di procedure diverse da quelle specificate possono provocare l'esposizione a.

Использование элементов настройки и выполнение процедур иных, чем указано здесь, может привести к опасному радиационному облучению.

Použitie kontrol, úprav alebo iných vykonaní od iných výrobcov, ako je v tomto špecifikované, mohlo by mať za následok nebezpečenstvo vystavenia sa vyžiarovaniu.

本書で指定された内容以外の、お客様による整備、調整、または手順を行った場合、レーザー光の放射の危険があります。

El uso de controles o ajustes o la ejecución de procedimientos distintos de los aquí especificados puede provocar la exposición a radiaciones peligrosas.

Opening the CD-ROM drive, the DVD-ROM drive, or any other optical storage device could result in exposure to hazardous laser radiation. There are no serviceable parts inside those drives. **Do not open.**

A CD-ROM drive, a DVD-ROM drive, or any other storage device installed may contain an embedded Class 3A or Class 3B laser diode. Note the following:

⚠ DANGER

Emits visible and invisible laser radiation when open. Do not stare into the beam, do not view directly with optical instruments, and avoid direct exposure to the beam.

Radiação por raio laser ao abrir. Não olhe fixo no feixe de luz, não olhe diretamente por meio de instrumentos óticos e evite exposição direta com o feixe de luz.

开启时会有激光发射时，请勿直视激光束，请勿直接查看视觉仪器，并且避免直接接触在激光光束之中。

Rayonnement laser si carter ouvert. Évitez de fixer le faisceau, de le regarder directement avec des instruments optiques, ou de vous exposer au rayon.

Laserstrahlung bei geöffnetem Gerät. Nicht direkt oder über optische Instrumente in den Laserstrahl sehen und den Strahlungsbereich meiden.

Kinyitáskor lézersugár ! Ne nézzen bele se szabad szemmel, se optikai eszközökkel. Kerülje a sugárnyalábbal való érintkezést!

Apriendo l'unità vengono emesse radiazioni laser. Non fissare il fascio, non guardarlo direttamente con strumenti ottici e evitare l'esposizione diretta al fascio.

Открывая, берегитесь лазерного излучения. Не смотрите на луч, не разглядывайте его с помощью оптических инструментов, а также избегайте прямого воздействия лазерного луча.

Keď je laserová jednotka otvorená. Vyhnite sa priamemu pohľadu a nehladte priamo s optickými nástrojmi do lúča a vyhnite sa priamemu vystaveniu lúčov.

開けるとレーザー光が放射されます。光線を見つめたり、光学機械を使って直接見たりしないでください。

Radiación láser al abrir. No mire fijamente ni examine con instrumental óptico el haz de luz. Evite la exposición directa al haz.

Important service information

This chapter presents the following important service information:

- “Strategy for replacing FRUs” on page 16
 - “Strategy for replacing a hard disk drive” on page 17
 - “Important notice for replacing a system board” on page 17
- “Important information about replacing RoHS compliant FRUs” on page 18

Important:

BIOS and device driver fixes are customer-installable. The BIOS and device drivers are posted on the customer support site:

<http://support.lenovo.com>.

Strategy for replacing FRUs

Before replacing parts:

Make sure that all software fixes, drivers, and BIOS downloads are installed before replacing any FRUs listed in this manual.

After a system board is replaced, ensure that the latest BIOS is loaded to the system board before completing the service action.

To download software fixes, drivers, and BIOS, follow the steps below:

1. Go to <http://support.lenovo.com>.
2. Enter the serial number or select a product or use Lenovo smart downloading.
3. Select the BIOS/Driver/Applications and download.
4. Follow the directions on the screen and install the necessary software.

Use the following strategy to prevent unnecessary expense for replacing and servicing FRUs:

- If you are instructed to replace an FRU, but the replacement does not solve the problem, reinstall the original FRU before you continue.
- Some computers have both a processor board and a system board. If you are instructed to replace either of them, and replacing one of them does not solve the problem, reinstall that board, and then replace the other one.
- If an adapter or a device consists of more than one FRU, any of the FRUs may be the cause of the error. Before replacing the adapter or device, remove the FRUs one by one to see if the symptoms change. Replace only the FRU that changed the symptoms.

Attention: The setup configuration on the computer you are servicing may have been customized. Running Automatic Configuration may alter the settings. Note the current configuration settings (using the View Configuration option); then, when service has been completed, verify that those settings remain in effect.

Strategy for replacing a hard disk drive

Always try to run a low-level format before replacing a hard disk drive. This will cause all customer data on the hard disk to be lost. Make sure that the customer has a current backup of the data before performing this action.

Attention: The drive startup sequence in the computer you are servicing may have been changed. Be extremely careful during write operations such as copying, saving, or formatting. If you select an incorrect drive, data or programs can be overwritten.

Important notice for replacing a system board

Some components mounted on a system board are very sensitive. Improper handling can cause damage to those components, and may cause a system malfunction.

Attention: When handling a system board:

- Do not drop the system board or apply any excessive force to it.
- Avoid rough handling of any kind.
- Avoid bending the system board and hard pushing to prevent cracking at each BGA (Ball Grid Array) chipset.

Important information about replacing RoHS compliant FRUs

RoHS, The Restriction of Hazardous Substances in Electrical and Electronic Equipment Directive (2002/95/EC) is a European Union legal requirement affecting the global electronics industry. RoHS requirements must be implemented on Lenovo products placed on the market after June 2006. Products on the market before June 2006 are not required to have RoHS compliant parts. If the original FRU parts are non-compliant, replacement parts can also be non-compliant. In all cases if the original FRU parts are RoHS compliant, the replacement part must also be RoHS compliant.

Note: RoHS and non-RoHS FRU part numbers with the same fit and function are identified with unique FRU part numbers.

Lenovo plans to transit to RoHS compliance well before the implementation date and expects its suppliers to be ready to support Lenovo’s requirements and schedule in the EU. Products sold in 2005 and 2006 will contain some RoHS compliant FRUs. The following statement pertains to these products and any product Lenovo produces containing RoHS compliant FRUs.

RoHS compliant FRUs have unique FRU part numbers. Before or after the RoHS implementation date, failed RoHS compliant parts must always be replaced with RoHS compliant ones, so only the FRUs identified as compliant in the system HMM or direct substitutions for those FRUs may be used.

Products marketed before June 2006		Products marketed after June 2006	
Current or original part	Replacement FRU	Current or original part	Replacement FRU
Non-RoHS	Can be Non-RoHS	Must be RoHS	Must be RoHS
Non-RoHS	Can be RoHS		
Non-RoHS	Can sub to RoHS		
RoHS	Must be RoHS		

Note: A direct substitution is a part with a different FRU part number that is automatically shipped by the distribution center at the time of the order.

General checkout

This chapter presents the following information:

- “What to do first” on page 20
- “Power system checkout” on page 21

Before you go to the checkout, make sure to read the following important notes:

Important notes:

- **Only certified trained personnel can service the computer.**
- **Before replacing any FRU, read the entire page on removing and replacing FRUs.**
- **Carefully remove screws for reuse when replacing FRUs.**
- **Be extremely careful during such write operations as copying, saving, or formatting.** Drives in the computer that you are servicing sequence might have been altered. If you select an incorrect drive, data or programs might be overwritten.
- **Replace an FRU only with another FRU of the correct model.** When you replace an FRU, make sure that the machine model and the FRU part number are correct by referring to the FRU parts list.
- **An FRU should not be replaced just because of a single, unreproducible failure.** Single failures can occur for a variety of reasons that have nothing to do with a hardware defect, such as cosmic radiation, electrostatic discharge, or software errors. Consider replacing an FRU only when a problem recurs. If you suspect that an FRU is defective, clear the error logs and run the test again. If the error does not recur, do not replace the FRU.
- **Be careful not to replace a nondefective FRU.**

What to do first

When you do return an FRU, you must include the following information in the parts exchange form or parts return form that you attach to it:

1. Name and phone number of servicer
2. Date of service
3. Date on which the machine failed
4. Date of purchase
5. Procedure index and page number in which the failing FRU was detected
6. Failing FRU name and part number
7. Machine type, model number, and serial number
8. Customer's name and address

Note for warranty: During the warranty period, the customer may be responsible for repair costs if the computer damage was caused by misuse, accident, modification, unsuitable physical or operating environment, or improper maintenance by the customer.

The following is a list of some common items that are not covered under warranty and some symptoms that might indicate that the system was subjected to stress beyond normal use.

Before checking problems with the computer, determine whether the damage is covered under the warranty by referring to the following list:

The following are not covered under warranty:

- LCD panel cracked from the application of excessive force or from being dropped
- Scratched (cosmetic) parts
- Distortion, deformation, or discoloration of the cosmetic parts
- Plastic parts, latches, pins, or connectors that have been cracked or broken by excessive force
- Damage caused by liquid spilled into the system
- Damage caused by the improper insertion of a PC Card or the installation of an incompatible card
- Improper disk insertion or use of an optical drive
- Diskette drive damage caused by pressure on the diskette drive cover, foreign material in the drive, or the insertion of a diskette with multiple labels
- Damaged or bent diskette eject button
- Fuses blown by attachment of a nonsupported device
- Forgotten computer password (making the computer unusable)
- Sticky keys caused by spilling a liquid onto the keyboard
- Use of an incorrect AC adapter on laptop products

The following symptoms might indicate damage caused by nonwarranted activities:

- Missing parts might be a symptom of unauthorized service or modification.
- If the spindle of a hard disk drive becomes noisy, it may have been subjected to excessive force, or dropped.

Power system checkout

To verify a symptom, follow the steps below:

1. Turn off the computer.
2. Remove the battery pack.
3. Connect the AC adapter.
4. Make sure that power is supplied when you turn on the computer.
5. Turn off the computer.
6. Disconnect the AC adapter and install the charged battery pack.
7. Make sure that the battery pack supplies power when you turn on the computer.

If you suspect a power problem, see the appropriate one of the following power supply checkouts:

- “Checking the AC adapter” on page 21
- “Checking operational charging” on page 22
- “Checking the battery pack” on page 22

Checking the AC adapter

You are here because the computer fails only when the AC adapter is used.

- If the power-on indicator does not turn on, check the power cord of the AC adapter for correct continuity and installation.
- If the computer does not charge during operation, go to “Checking operational charging”.

To check the AC adapter, follow the steps below:

1. Unplug the AC adapter cable from the computer.
2. Measure the output voltage at the plug of the AC adapter cable. See the following figure:

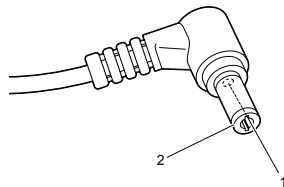

Pin	Voltage (V DC)
1	+20
2	0

Note: Output voltage for the AC adapter pin No. 2 may differ from the one you are servicing.

3. If the voltage is not correct, replace the AC adapter.
4. If the voltage is acceptable, do the following:
 - Replace the system board.
 - If the problem persists, go to “Lenovo YOGA 530-14IKB/YOGA 530-14ARR” on page 27.

Note: Noise from the AC adapter does not always indicate a defect.

Checking operational charging

To check whether the battery charges properly during operation, use a discharged battery pack or a battery pack that has less than 50% of the total power remaining when installed in the computer.

Perform operational charging. If the battery status indicator or icon does not light on, remove the battery pack and let it return to room temperature. Reinstall the battery pack. If the charge indicator or icon is still off, replace the battery pack.

If the charge indicator still does not light on, replace the system board. Then reinstall the battery pack. If it is still not charged, go to the next section.

Checking the battery pack

Battery charging does not start until the Power Meter shows that less than 95% of the total power remains; under this condition the battery pack can charge to 100% of its capacity. This protects the battery pack from being overcharged or from having a shortened life.

To check your battery, move your cursor to the Power Meter icon in the icon tray of the Windows[®] taskbar and wait for a moment (but do not click it), and the percentage of battery power remaining is displayed. To get detailed information about the battery, double-click the Power Meter icon.

Note: If the battery pack becomes hot, it may not be able to be charged. Remove it from the computer and leave it at room temperature for a while. After it cools down, reinstall and recharge it.

Related service information

This chapter presents the following information:

- “Restoring the factory contents by using Push-button reset” on page 23
- “Passwords” on page 24
- “Power management” on page 25

Restoring the factory contents by using Push-button reset

Restore of factory default

The Lenovo YOGA 530-14IKB/YOGA 530-14ARR computers come with pre-installed Push-button reset. In order to save application files and the initial backed up files of the system, the hard disk in a Lenovo computer includes a hidden partition when it is shipped. If you need to restore the system to the point of your first boot up, press the Novo button and run **System Recovery**. For details of “Push-button reset”, see the *Recovery system* in the *User Guide*.

Note: This will delete all the new data on the system partition (C drive), which is not recoverable. Make sure to back up your critical data before you perform this action.

When you use the recovery discs to boot your computer, the system will enter the user interface for system recovery automatically. Please follow the prompt to insert the backup discs to complete the whole recovery process.

Note: The recovery process might take up to 2 hours.

Passwords

As many as three passwords may be needed for any Lenovo computer: the power-on password (POP), the hard disk password (HDP), and the administrator password.

If any of these passwords has been set, a prompt for it appears on the screen whenever the computer is turned on. The computer does not start until the password is entered.

Power-on password

A power-on password (POP) protects the system from being powered on by an unauthorized person. The password must be entered before an operating system can be booted.

Hard-disk password

There are two hard-disk passwords (HDPs):

+ User HDP - for the user

+ Master HDP - for the system administrator, who can use it to get access to the hard disk drive even if the user has changed the user HDP

Attention: If the user HDP has been forgotten, check whether a master HDP has been set. If it has, it can be used for access to the hard disk drive. If no master HDP is available, neither Lenovo nor Lenovo authorized service technicians provide any services to reset either the user or the master HDP, or to recover data from the hard disk drive. The hard disk drive can be replaced for a scheduled fee.

Administrator password

Administrator password controls the access of the whole setup utility. Only after the Administrator password has been set can the User password be set. If Administrator password was cleared, the User password was cleared too.

Power management

Note: Power management modes are not supported for APM operating system.

To reduce power consumption, the computer has two power management modes: sleep (standby), and hibernation.

Putting the computer to sleep or shutting it down

When you have finished working with your computer, you can put it to sleep or shut it down.

Putting your computer to sleep

If you will be away from your computer for only a short time, put the computer to sleep.

When the computer is in sleep mode, you can quickly wake it to resume use, bypassing the startup process.

To put the computer to sleep, do one of the following:

- Close the display lid.
- Press the Power button.
- Move the cursor to the lower-left corner, and then select the Start button.
Select **Power**  → **Sleep**.

Note: Put your computer to sleep before you move it. Moving your computer while the hard disk drive is spinning can damage the hard disk, causing loss of data.

To wake up the computer, perform the following:

- Press any key on the keyboard.
- Press the Power button.

Lenovo YOGA 530-14IKB/YOGA 530-14ARR

This chapter presents the following product-specific service references and product-specific parts information:

- “Specifications” on page 27
- “Status indicators” on page 29
- “Hotkeys” on page 30
- “FRU replacement notices” on page 31
- “Removing and replacing an FRU” on page 32
- “Locations” on page 59
- “Parts list” on page 61

Specifications

The following table lists the specifications of the Lenovo YOGA 530-14IKB/YOGA 530-14ARR:

Table 1. Specifications

Form Factor	
Dimensions	Appr. 328 mm × 229 mm × 17.6 mm
Weight	Appr. 1.60 kg with battery
LCD size	14.0-inch
Processor	
See the system properties of your computer, you can do this as follows: Click Control Panel , then click Hardware and Sound , click Device Manager under Devices and Printers and double click Processors .	
Memory	
Type and speed	DDR4, 2133 MHz/2400 MHz
Maximum supported capacity	16 GB
Storage	
Capacity	SSD, 128 GB / 256 GB / 512 GB
Interface	PCIe
Display	
Screen	Multi-touch screen
Display resolution (LCD)	16:9, 1,366 × 768 pixels HD/ 1,920 × 1,080 pixels FHD
LCD backlight	LED
I/O Ports	
USB	USB 3.0 × 2, Type-C (USB 3.0 only) × 1
Audio	Combo audio jack × 1
Video/Audio	HDMI slot × 1
Memory card slot	4-in-1 (SD, SDHC, SDXC, MMC)

Table 1. Specifications (continued)

Battery pack	
Type	Polymer
Cells/Capacity	4 Cell, 45 Wh
Note: The capacity given here is the typical or average capacity as measured in a specific test environment. Capacities measured in other environments may differ but are no lower than the rated capacity (see product label).	
AC power adapter	
Input	100-240 V, 50-60 Hz
Output voltage	20 V DC
Power	65 W
Miscellaneous	
Camera	HD
Security	Kensington Mini Security slot × 1

Status indicators

The system status indicators below show the computer status:

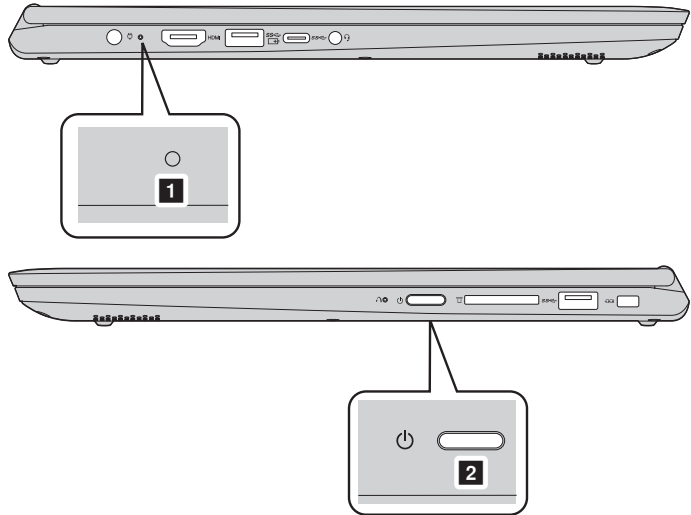

Table 2. Status indicators

1 Battery/Charging status LED

AC power adapter status	LED status	Meaning
Disconnected	Off	The battery is not charging.
Connected	Solid amber	The battery has between 1% and 80% charge and is still charging.
	Solid white	The battery has more than 80% charge, charging will continue until the battery is fully charged.













2 Power button/Power status indicator

Indicator	Indicator status	Meaning
Power status indicator	On (solid white)	The computer is powered on and the battery has between 20% and 100% charge.
	On (solid amber)	The computer is powered on and the battery has between 1% and 20% charge.
	Slow blinking amber	The computer is in sleep mode and the battery has between 1% and 20% charge.
	Slow blinking white	The computer is in sleep mode and the battery has between 20% and 100% charge.
	Off	The computer is powered off.

Hotkeys

You can access certain system settings quickly by pressing the appropriate hotkeys.

Table 3. Hotkeys

 F1	: Mutes/unmutes the sound.	 F7	: Enables/disables airplane mode.
 F9	: Decreases the volume level.	 F9	: Enables/disables camera.
 F9	: Increases the volume level.	 F10	: Locks the LCD screen.
 F4	: Enables/disables microphone.	 F10	: Enables the external projector or dangles the external display.
 F5	: Refreshes page.	 F11	: Decreases display brightness.
 F6	: Enables/disables the touch pad.	 F12	: Increases display brightness.

FRU replacement notices

This section presents notices related to removing and replacing parts. Read this section carefully before replacing any FRU.

Screw notices

Loose screws can cause a reliability problem. In the Lenovo computer, this problem is addressed with special nylon-coated screws that have the following characteristics:

- They maintain tight connections.
- They do not easily come loose, even with shock or vibration.
- They are harder to tighten.
- Each one should be used only once.

Do the following when you service this machine:

- Keep the screw kit in your tool bag.
- Carefully remove screws for reuse when replacing FRUs.
- Use a torque screwdriver if you have one.

Tighten screws as follows:

- **Plastic to plastic**

Turn an additional 90° after the screw head touches the surface of the plastic part:

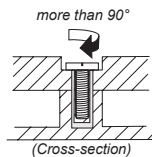

- **Logic card to plastic**

Turn an additional 180° after the screw head touches the surface of the logic card:

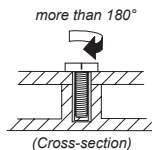

- **Torque driver**

If you have a torque screwdriver, refer to the “Torque” column for each step.

- Make sure that you use the correct screws. If you have a torque screwdriver, tighten all screws firmly to the torque shown in the table. **Carefully remove screws for reuse when replacing FRUs. Make sure that all screws are tightened firmly.**
- Ensure torque screwdrivers are calibrated correctly following country specifications.

Removing and replacing an FRU

This section presents exploded figures with the instructions to indicate how to remove and replace the FRU. Make sure to observe the following general rules:

1. Do not attempt to service any computer unless you have been trained and certified. An untrained person runs the risk of damaging parts.
2. Before replacing any FRU, review “FRU replacement notices” on page 31.
3. Begin by removing any FRUs that have to be removed before the failing FRU. Any of such FRUs are listed at the top of the page. Remove them in the order in which they are listed.
4. Follow the correct sequence in the steps to remove the FRU, as given in the figures by the numbers in square callouts.
5. When turning a screw to replace an FRU, turn it in the direction as given by the arrow in the figure.
6. When removing the FRU, move it in the direction as given by the arrow in the figure.
7. To put the new FRU in place, reverse the removal procedures and follow any of the notes that pertain to replacement. For information about connecting and arranging internal cables, see “Locations” on page 59.
8. When replacing an FRU, use the correct screw as shown in the procedures.

 **DANGER**

Before removing any FRU, turn off the computer, unplug all power cords from electrical outlets, remove the battery pack, and then disconnect any of the interconnecting cables.

Attention: After replacing an FRU, do not turn on the computer until you have made sure that all screws, springs, and other small parts are in place and none are loose inside the computer. Verify this by shaking the computer gently and listening for rattling sounds. Metallic parts or metal flakes can cause electrical short circuits.

Attention: The system board is sensitive to, and can be damaged by, electrostatic discharge. Before touching it, establish personal grounding by touching a ground point with one hand or using an electrostatic discharge (ESD) strap (P/N 6405959) to remove potential shock reasons.

1010 Base cover

Figure 1. Removal steps of base cover

Remove the screws ■.

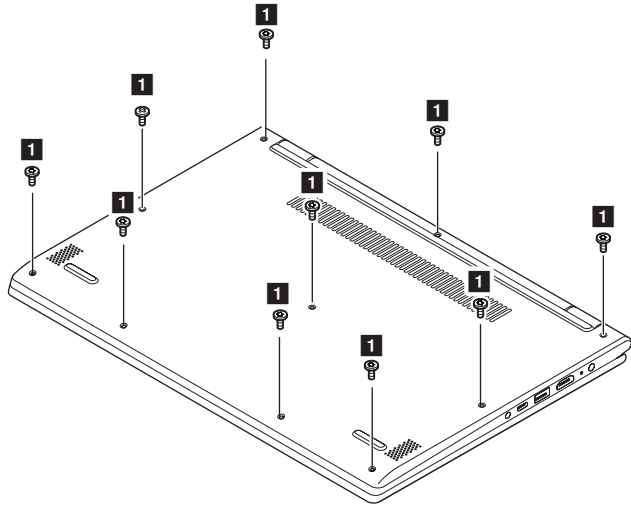

Step	Screw (quantity)	Color	Torque
■	M2 × 6.5 mm, plum flower head (10)	Silver	1.85kg±0.15kgf.cm

Figure 1. Removal steps of base cover (continued)

Remove the base cover in the directions shown by arrows **2** and **3**.

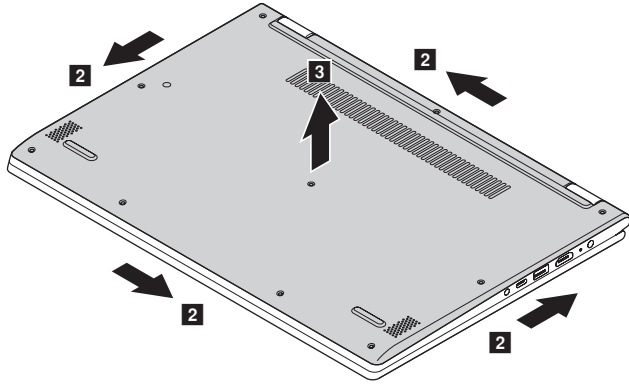

Note: Applying labels to the base cover

The new base cover FRU is shipped with a kit containing labels of several kinds. When you replace the base cover, you need to apply the following labels:

The following labels need to be peeled off from the old base cover and put on the new base cover.

- a** Rating label 70 × 24 mm
- b** Rating print 43 × 24 mm
- c** GML Label 16.077 × 22.501 mm
- d** WL/BT label 35 × 15 mm
- e** KCC label 50 × 16 mm
- f** Adapter label 65 × 20 mm
- g** BIS label 22 × 30 mm
- h** Indonesia label 32 × 10 mm
- i** Argentina label 68 × 6 mm
- j** TW label 70 × 10 mm

For some models, you also need to apply one or two FCC labels. Check the old base cover; if it has one or two FCC labels, find duplicates of them in the label kit and apply them to the new base cover.

For the location of each label, refer to the following figures:

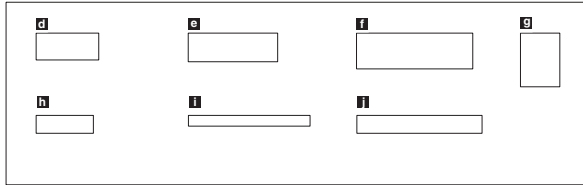
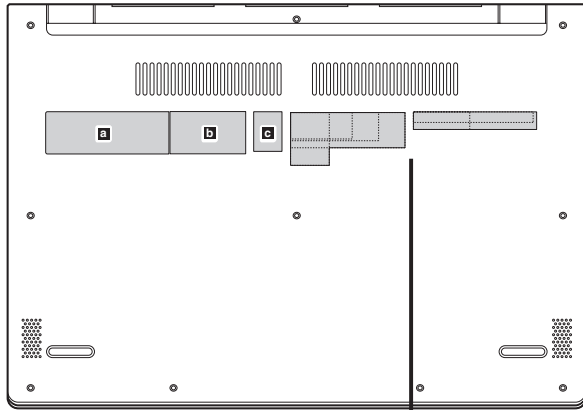

1020 Battery pack

⚠ DANGER

Only use the battery specified in the parts list for your computer. Any other battery could ignite or explode.

For access, remove these FRUs in order:

- “1010 Base cover” on page 33

Figure 2. Removal steps of battery pack

Detach the battery pack connector in the direction shown by arrow **1**. Remove the screws **2**.

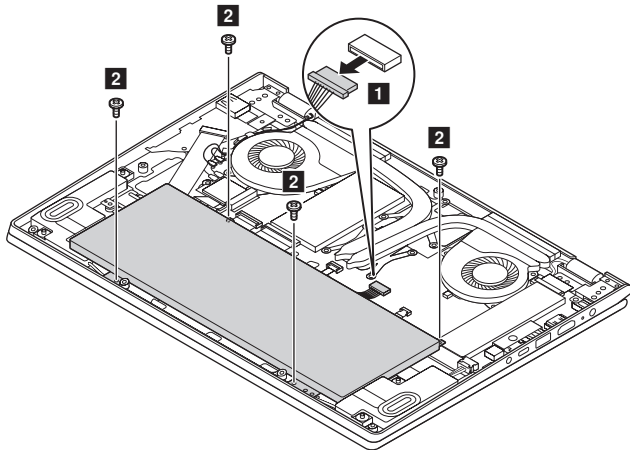

When installing: Make sure that the connector is attached firmly.

Step	Screw (quantity)	Color	Torque
2	M2 × 3.5 mm, Phillips-head (4)	Black	1.85kg±0.15kgf.cm

Figure 2. Removal steps of battery pack (continued)

Remove the battery pack in the direction shown by arrow **3**.

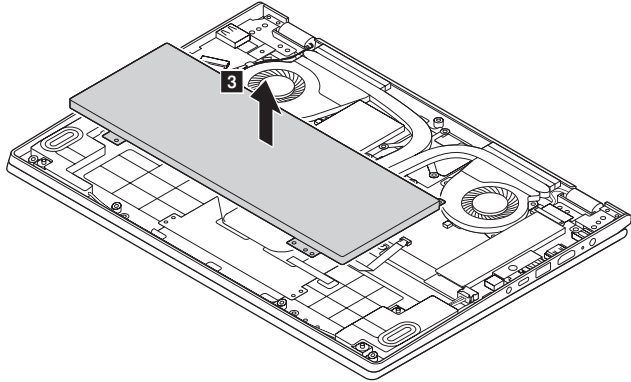

1030 PCI Express Mini Card for wireless LAN

For access, remove these FRUs in order:

- “1010 Base cover” on page 33
- “1020 Battery pack” on page 37

Important:

The preinstalled WLAN module may only be replaced with a Lenovo approved module in order to comply with FCC and IC regulations. Refer to Table 4 “Parts list—Overall” on page 63 for Lenovo part numbers for the approved modules.

Figure 3. Removal steps of PCI Express Mini Card for wireless LAN

Unplug the two wireless LAN cables (black, grey) **1**, and then remove the screw **2**.

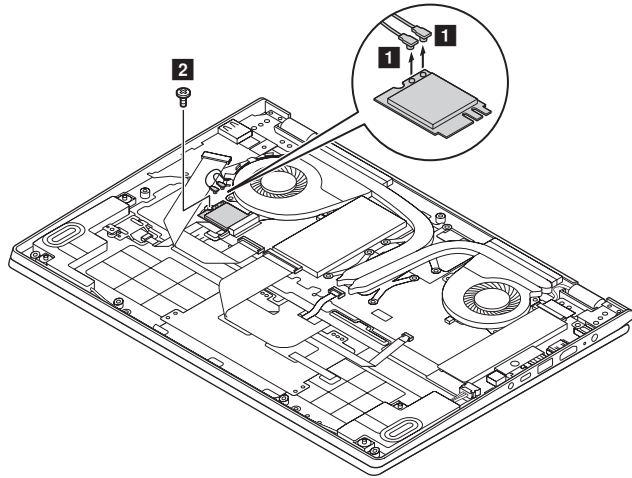

In step **1**, unplug the jacks by using the removal tool antenna RF connector (P/N: 08K7159), or pick up the connectors with your fingers and gently unplug them in the direction shown by the arrows.

Step	Screw (quantity)	Color	Torque
2	M2 × 3.5 mm, Phillips-head (1)	Black	1.85kg±0.15kgf.cm

Figure 3. Removal steps of PCI Express Mini Card for wireless LAN (continued)

Remove the card in the direction shown by arrow **3**.

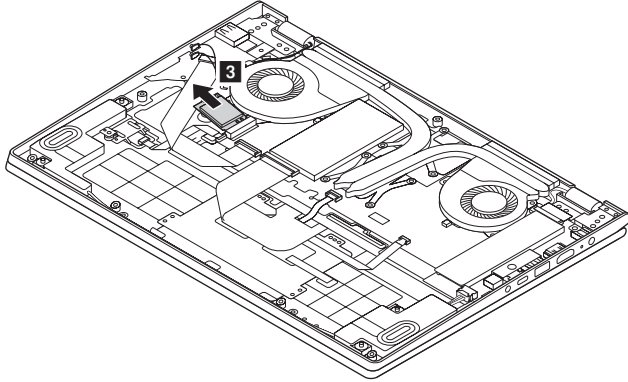

When installing:

Plug the black cable into the jack labeled **MAIN**, and the grey cable into the jack labeled **AUX** on the card.

1040 DIMM

For access, remove these FRUs in order:

- “1010 Base cover” on page 33
- “1020 Battery pack” on page 37
- “1030 PCI Express Mini Card for wireless LAN” on page 39

Figure 4. Removal steps of DIMM

Remove the DIMM cover in the direction shown by arrow **1**.

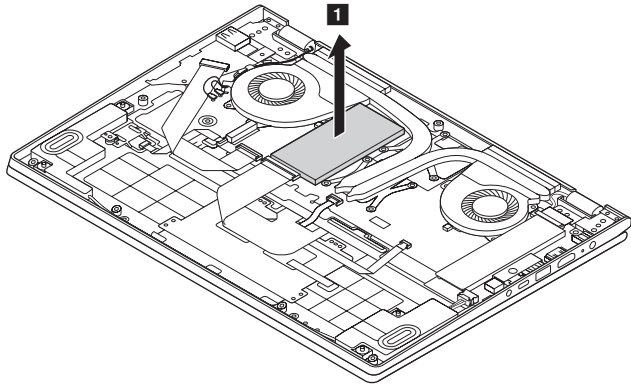

Release the two latches on both edges of the socket at the same time in the directions shown by arrows **2**, and then unplug the DIMM in the direction shown by arrow **3**.

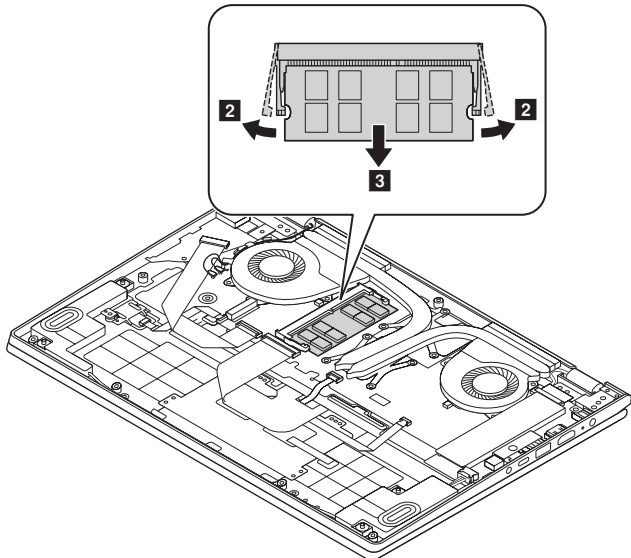

1050 SSD card

For access, remove these FRUs in order:

- “1010 Base cover” on page 33
- “1020 Battery pack” on page 37
- “1030 PCI Express Mini Card for wireless LAN” on page 39
- “1040 DIMM” on page 41

Attention:

- **Do not drop the SSD card or apply any physical shock to it.** The SSD card is sensitive to physical shock. Improper handling can cause damage and permanent loss of data.
- Before removing the SSD card, suggest the customer to backup all the information on it if possible.
- Never remove the SSD card while the system is operating or in suspend mode.

Figure 5. Removal steps of SSD card

Remove the SSD cover in the direction shown by arrow **1**.

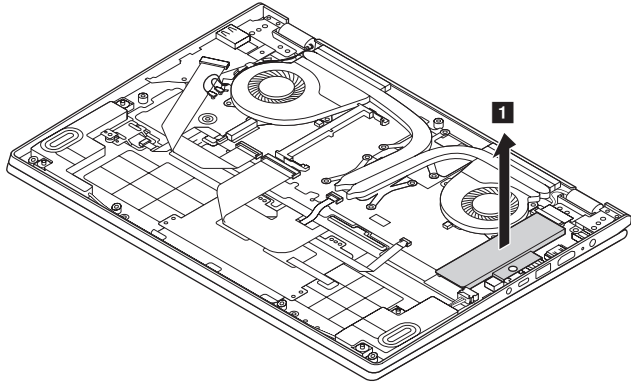

Lenovo YOGA 530-14IKB/YOGA 530-14ARR

Remove the screw **2**. Then remove the SSD card in the direction shown by arrow **3**.

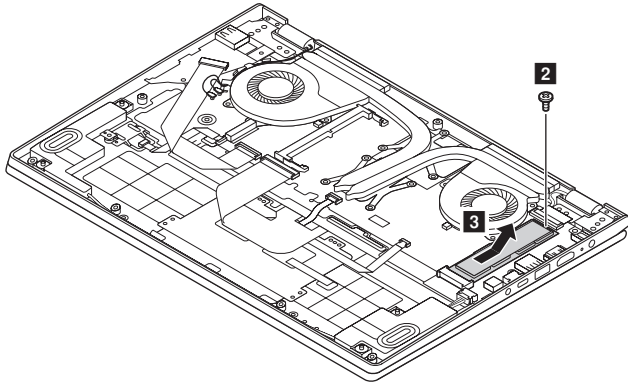

Step	Screw (quantity)	Color	Torque
2	M2 x 3.5 mm, Phillips-head (1)	Black	1.85kg±0.15kgf.cm

1060 Speakers

For access, remove these FRUs in order:

- “1010 Base cover” on page 33
- “1020 Battery pack” on page 37
- “1030 PCI Express Mini Card for wireless LAN” on page 39
- “1040 DIMM” on page 41
- “1050 SSD card” on page 42

Figure 6. Removal steps of speakers

Unplug the speaker connector in the direction shown by arrow **1**. Then remove the speakers **2**.

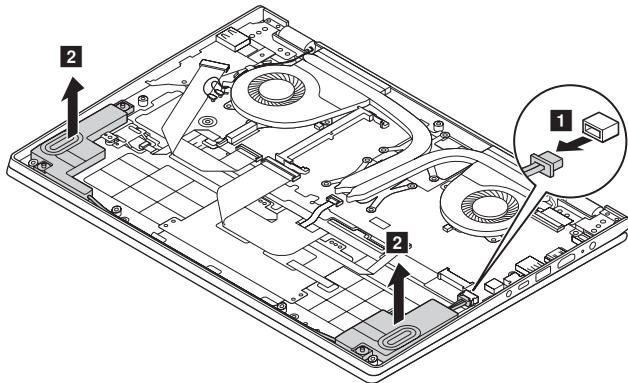

When installing: Make sure that the connector is attached firmly.

1070 Fan and heat sink assembly

For access, remove these FRUs in order:

- “1010 Base cover” on page 33
- “1020 Battery pack” on page 37
- “1030 PCI Express Mini Card for wireless LAN” on page 39
- “1040 DIMM” on page 41
- “1050 SSD card” on page 42
- “1060 Speakers” on page 44

Figure 7. Removal steps of fan and heat sink assembly

Release the cables from the cable guides in the direction shown by arrow **1**.

Unplug the fan connectors in the direction shown by arrow **2**.

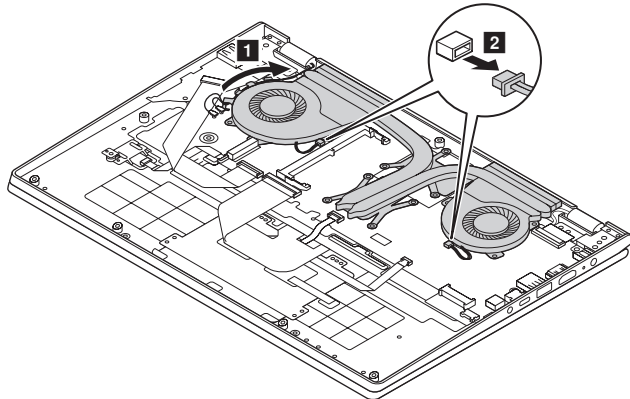

When installing: Route the antenna cables along the cable guides. As you route the cables, make sure that they are not subjected to any tension. Tension could cause the cables to be damaged by the cable guides, or a wire to be broken. Make sure that the connectors are attached firmly.

Remove the screws **3**. Loosen the screws **4**.

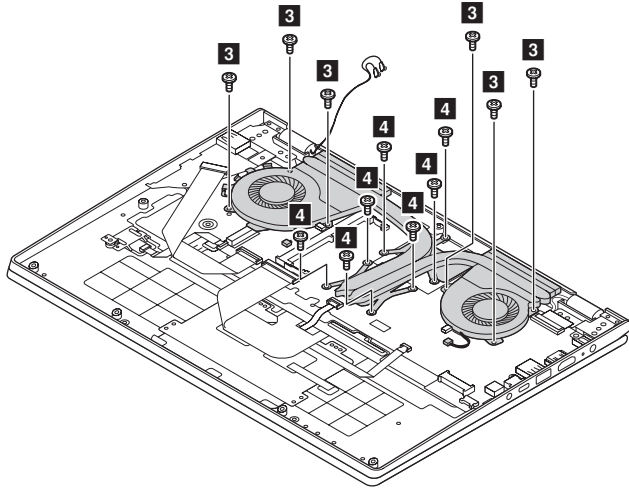

Step	Screw (quantity)	Color	Torque
3	M2 x 3.5 mm, Phillips-head (6)	Black	1.85kg±0.15kgf.cm

Remove the fan and heat sink assembly in the direction shown by arrow **5**. Be careful not to damage the connector.

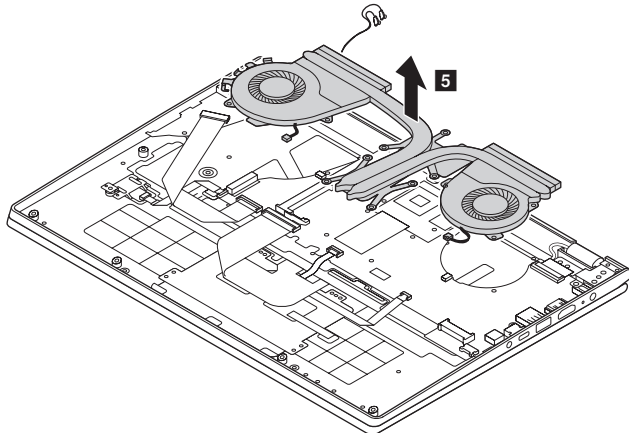

1080 Upper case

For access, remove these FRUs in order:

- “1010 Base cover” on page 33
- “1020 Battery pack” on page 37
- “1030 PCI Express Mini Card for wireless LAN” on page 39
- “1040 DIMM” on page 41
- “1050 SSD card” on page 42
- “1060 Speakers” on page 44
- “1070 Fan and heat sink assembly” on page 45

Figure 8. Removal steps of upper case

Disconnect the connector in the direction shown by arrow ■.

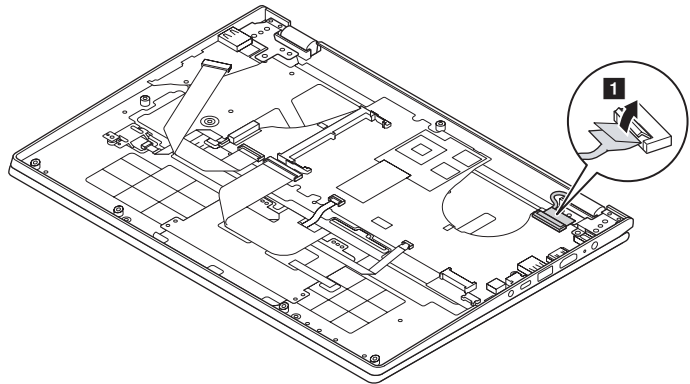

When installing: Make sure that the connector is attached firmly.

Figure 8. Removal steps of upper case (continued)

Remove the screws **2**.

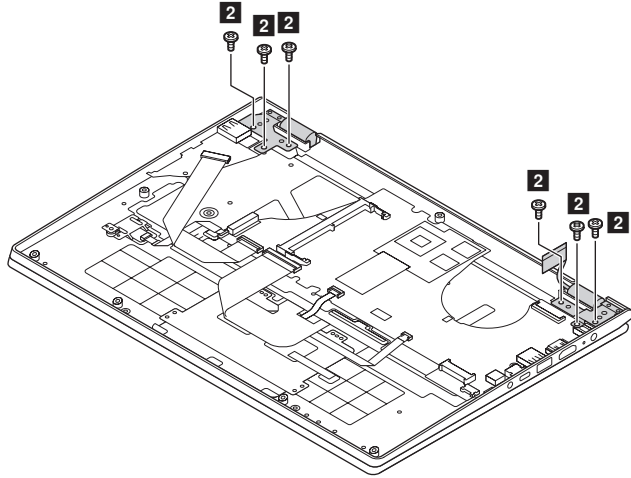

Step	Screw (quantity)	Color	Torque
2	M2.5 × 4 mm, Phillips-head (6)	Silver	3kg±0.3kgf.cm

Figure 8. Removal steps of upper case (continued)

Open the hinge in the direction shown by arrows **3**.

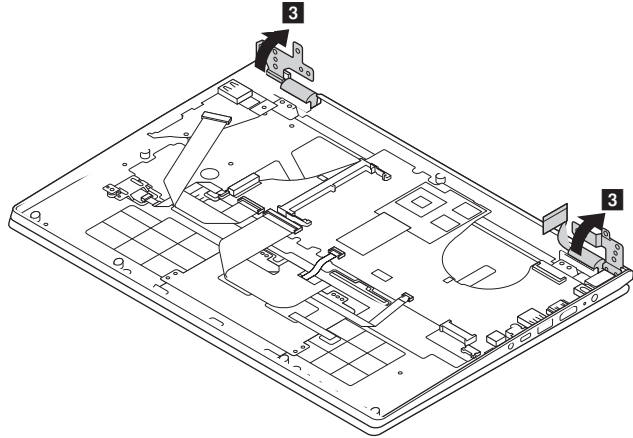

Remove the upper case from the LCD module in the direction shown by arrow **4**.

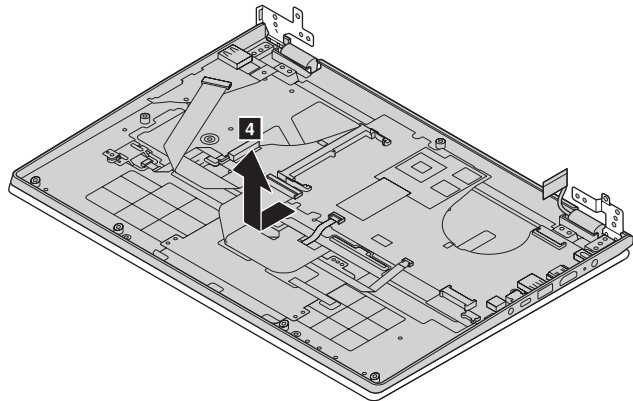

1090 System board

Important notices for handling the system board:

When handling the system board, bear the following in mind.

- Be careful not to drop the system board on a bench top that has a hard surface, such as metal, wood, or composite.
- Avoid rough handling of any kind.
- During the whole process, make sure not to drop or stack the system board.
- If you put a system board down, make sure to put it only on a padded surface such as an ESD mat or conductive corrugated material.

For access, remove these FRUs in order:

- “1010 Base cover” on page 33
- “1020 Battery pack” on page 37
- “1030 PCI Express Mini Card for wireless LAN” on page 39
- “1040 DIMM” on page 41
- “1050 SSD card” on page 42
- “1060 Speakers” on page 44
- “1070 Fan and heat sink assembly” on page 45
- “1080 Upper case” on page 47

Figure 9. Removal steps of system board

Disconnect the connectors in the directions shown by arrows ■ - ■.

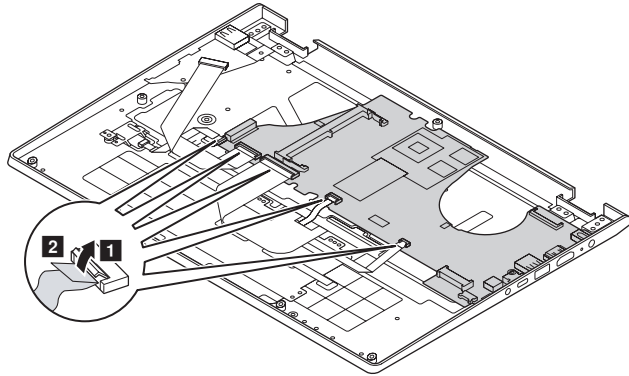

When installing: Make sure that the connectors are attached firmly.

Figure 9. Removal steps of system board (continued)

Remove the screws **3**. And then remove the system board in the direction shown by arrow **4**.

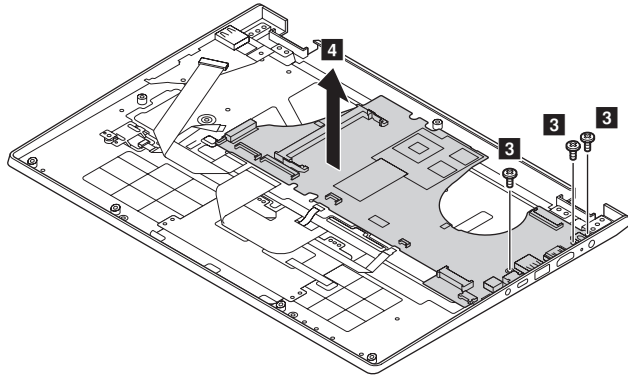

Step	Screw (quantity)	Color	Torque
3	M2 × 3.5 mm, Phillips-head (3)	Black	1.85kg±0.15kgf.cm

1100 I/O board

For access, remove these FRUs in order:

- “1010 Base cover” on page 33
- “1020 Battery pack” on page 37
- “1030 PCI Express Mini Card for wireless LAN” on page 39
- “1040 DIMM” on page 41
- “1050 SSD card” on page 42
- “1060 Speakers” on page 44
- “1070 Fan and heat sink assembly” on page 45
- “1080 Upper case” on page 47
- “1090 System board” on page 50

Figure 10. Removal steps of I/O board

Remove the screws **■** and I/O board **2**.

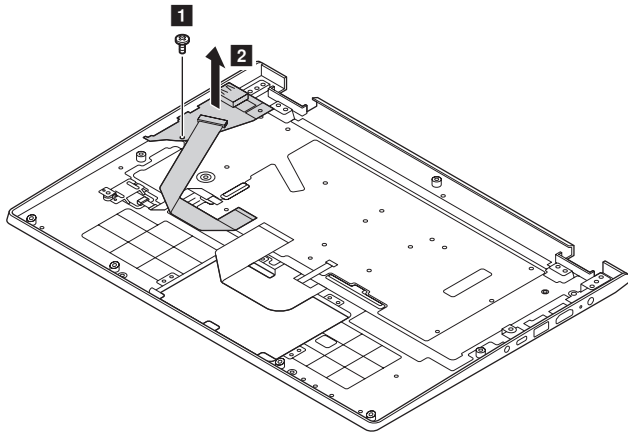

Step	Screw (quantity)	Color	Torque
■	M2 × 3.5 mm, Phillips-head (1)	Black	1.85kg±0.15kgf.cm

1110 LCD unit

For access, remove these FRUs in order:

- “1010 Base cover” on page 33
- “1020 Battery pack” on page 37
- “1030 PCI Express Mini Card for wireless LAN” on page 39
- “1040 DIMM” on page 41
- “1050 SSD card” on page 42
- “1060 Speakers” on page 44
- “1070 Fan and heat sink assembly” on page 45
- “1080 Upper case” on page 47
- “1090 System board” on page 50
- “1100 I/O board” on page 52

Figure 11. Removal steps of LCD unit

Pull out the cap rubber in the direction shown by arrow **1**. Remove the hinge cap in the directions shown by arrows **2**.

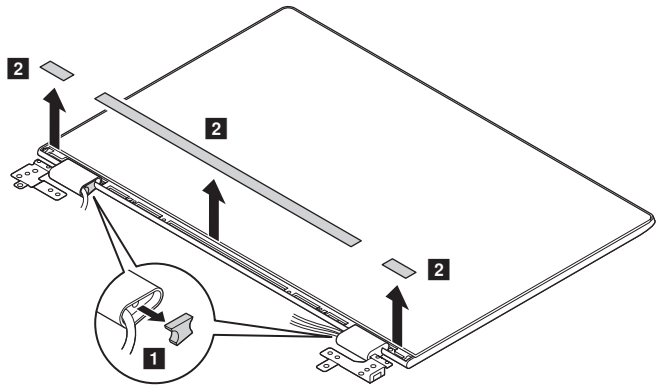
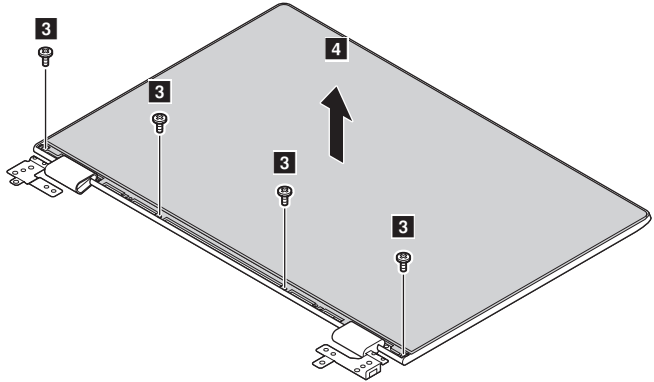

Figure 11. Removal steps of LCD unit (continued)

Remove the screws **3**. Blow-dry the LCD along the sides. Remove the panel in the direction shown by arrow **4**.

Note: Heating the tapes below the LCD to 60°C, tear off the tapes.



Step	Screw (quantity)	Color	Torque
3	M2 × 3.0 mm, Phillips-head (4)	Silver	1.85kg±0.15kgf.cm

Figure 11. Removal steps of LCD unit (continued)

Remove the screws 5.

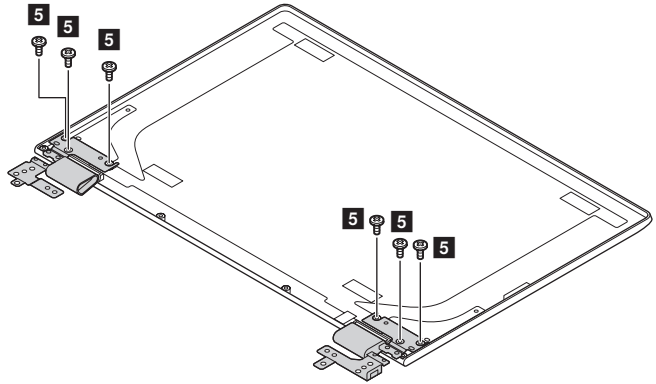

Step	Screw (quantity)	Color	Torque
■	M2 × 2 mm, Phillips-head (6)	Black	1.85kg±0.15kgf.cm

Figure 11. Removal steps of LCD unit (continued)

Remove hinges in the directions shown by arrows **6**.

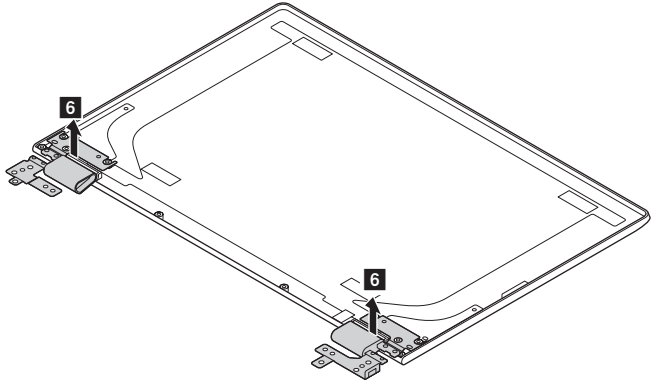

1120 MIC board, sensor board, camera and EDP cable

For access, remove these FRUs in order:

- “1010 Base cover” on page 33
- “1020 Battery pack” on page 37
- “1030 PCI Express Mini Card for wireless LAN” on page 39
- “1040 DIMM” on page 41
- “1050 SSD card” on page 42
- “1060 Speakers” on page 44
- “1070 Fan and heat sink assembly” on page 45
- “1080 Upper case” on page 47
- “1090 System board” on page 50
- “1100 I/O board” on page 52
- “1110 LCD unit” on page 53

Figure 12. Removal steps of MIC board, sensor board, camera and EDP cable

Disconnect the connectors in the directions shown by arrows ■ - 3.

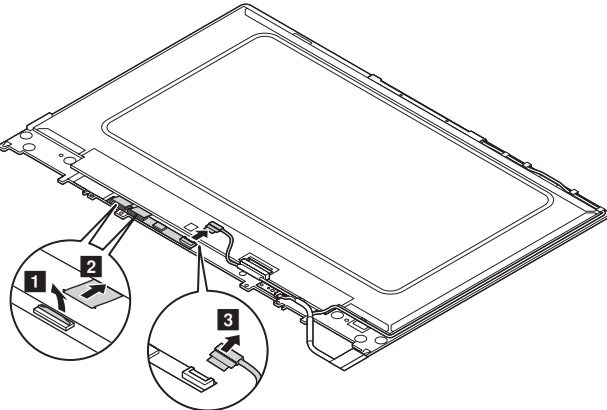

When installing: Make sure that the connectors are attached firmly.

Disconnect the connectors in the directions shown by arrows **4**. Remove the sensor board and MIC board in the directions shown by arrows **5**, **6**.

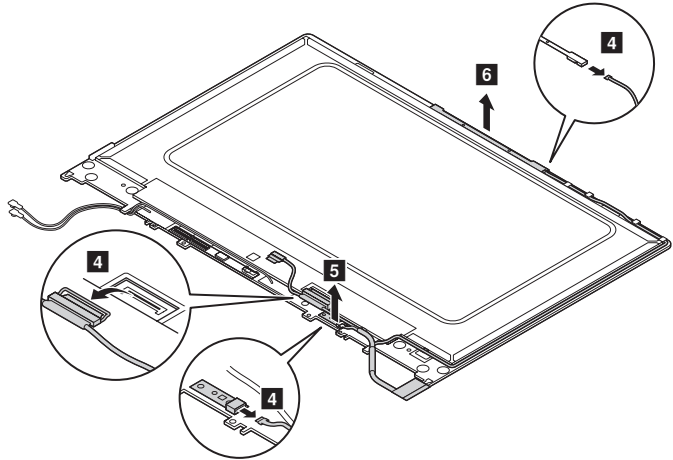

When installing: Make sure that the connectors are attached firmly.

Disconnect the connector in the direction shown by arrow **7**. Remove the camera and EDP cable in the directions shown by arrows **8**, **9**.

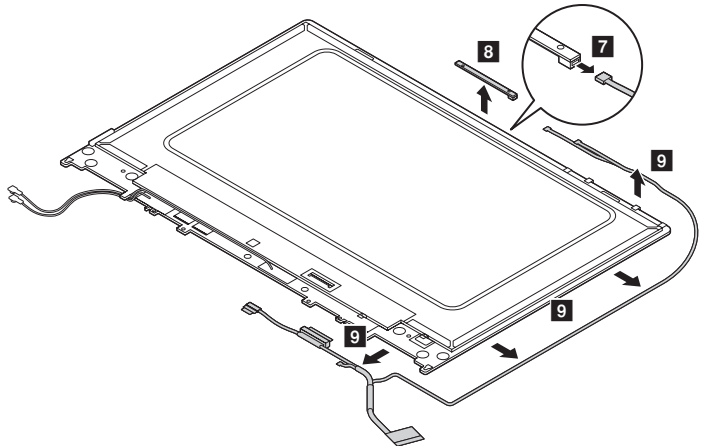

When installing: Make sure that the connectors are attached firmly.

Locations

Front view and right-side view

- Integrated camera
- 2 Built-in microphone
- 3 Multi-touch screen (on select models)
- 4 Wireless LAN antennas
- 5 Touch pad
- 6 Fingerprint reader (on select models)
- 7 Kensington Mini Security slot
- 8 USB 3.0 port
- 9 Memory card slot
- 10 Power button/Power status indicator $\text{\textcircled{P}}$
- 11 Novo button

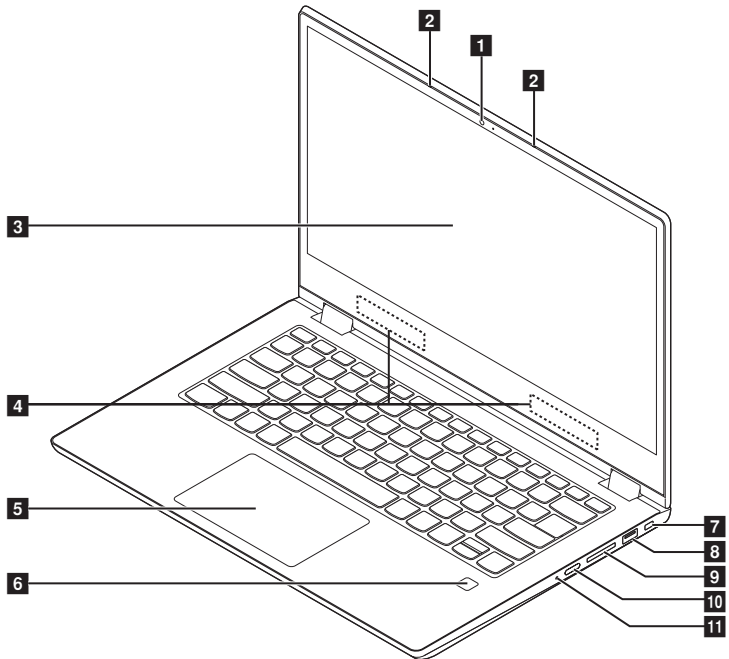

Bottom and Left-side view

- Speakers
- 2 Ventilation slots
- 3 AC power adapter jack
- 4 Battery/Charging status LED
- 5 HDMI port
- 6 USB 3.0 port
- 7 Type-C port
- 8 Combo audio jack

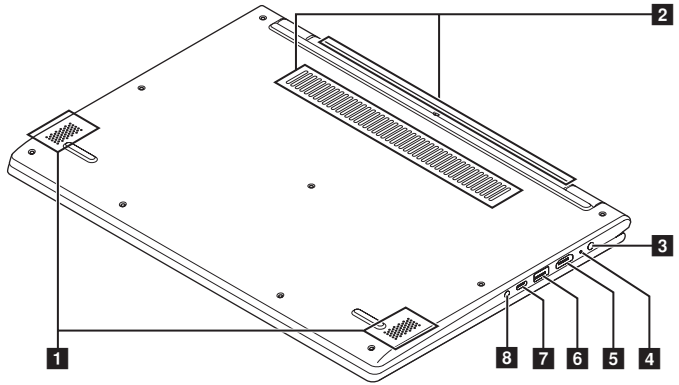

Parts list

This section presents the following service parts:

- “Overall” on page 62
- “LCD FRUs” on page 79
- “Miscellaneous parts” on page 81
- “AC power adapters” on page 81
- “Screws” on page 84

Note:

Each FRU is available for all types or models, unless specific types or models are specified.

Attention:

Do not attempt to replace an FRU on your own. If an FRU is damaged, contact a Lenovo authorized servicer or a marketing representative for replacement or repair. Only qualified technicians can inspect or repair this product.

Overall

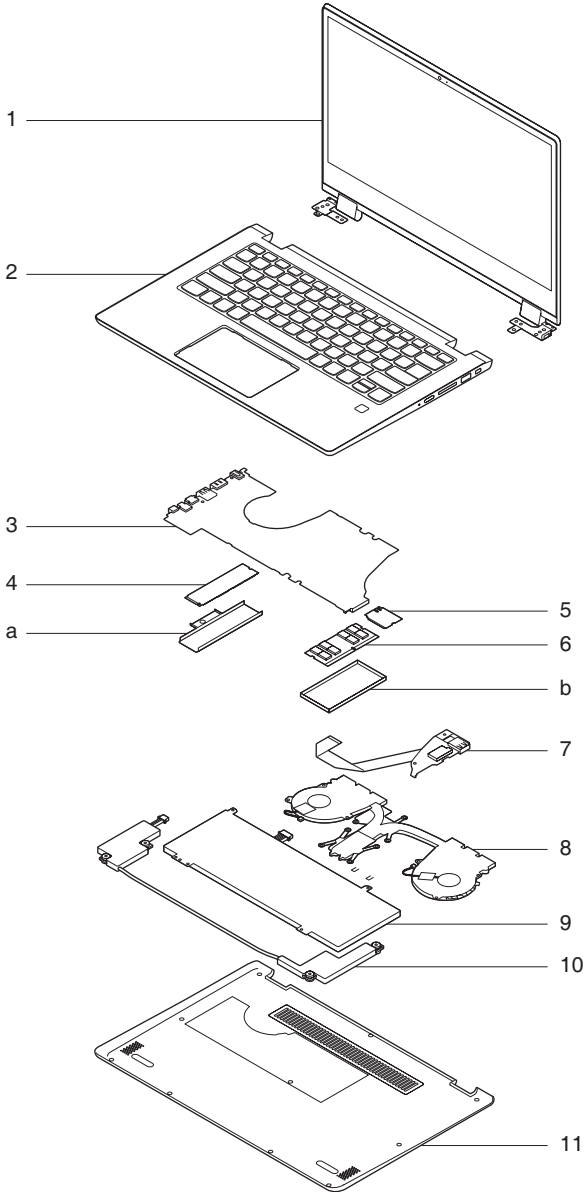

Table 4. Parts list—Overall

No.	FRU	FRU no.	CRU ID.
a-d	See "Miscellaneous parts" on page 81.		
1	LCD unit (see "LCD FRUs" on page 79).		
2	UpperCase L 81EK W/KB IG FP BL GK	5CB0R08775	N
2	UpperCase L 81EK W/KB IG FP BL UI	5CB0R08852	
2	UpperCase L 81EK W/KB IG FP BL KO	5CB0R08723	
2	UpperCase L 81EK W/KB IG FP BL CH	5CB0R08653	
2	UpperCase L 81EK W/KB IG FP BL RU	5CB0R08795	
2	UpperCase L 81EK W/KB IG FPBL AR-E	5CB0R08638	
2	UpperCase L 81EK W/KB IG FP BL HB	5CB0R08663	
2	UpperCase L 81EK W/KB IG FP BL TI	5CB0R08598	
2	UpperCase L 81EK W/KB IGFPBL INDIA	5CB0R08831	
2	UpperCase L 81EK W/KB IG FP BL UA	5CB0R08483	
2	UpperCase L 81EK W/KB IG FP BL UK	5CB0R08819	
2	UpperCase L 81EK W/KB IG FP BL IT	5CB0R08583	
2	UpperCase L 81EK W/KB IG FP BL SP	5CB0R08468	
2	UpperCase L 81EK W/KB IG FP BL TR	5CB0R08712	
2	UpperCase L 81EK W/KB IG FP BL PO	5CB0R08888	
2	UpperCase L 81EK W/KB IG FP BL LA	5CB0R08679	
2	UpperCase L 81EK W/KB IG FPBL CF-E	5CB0R08836	
2	UpperCase L 81EK W/KB IG FP BL ND	5CB0R08693	
2	UpperCase L 81EK W/KB IG FP BL FR	5CB0R08604	
2	UpperCase L 81EK W/KB IG FP BL GR	5CB0R08491	
2	UpperCase L 81EK W/KB IG FP BL NL	5CB0R08751	
2	UpperCase L 81EK W/KB IG FP BL HG	5CB0R08574	
2	UpperCase L 81EK W/KB IG FP BL BE	5CB0R08793	
2	UpperCase L 81EK W/KB IG FP BL ICE	5CB0R08714	
2	UpperCase L 81EK W/KB IG FP BL SA	5CB0R08671	
2	UpperCase L 81EK W/KB IG FP BL SW	5CB0R08470	
2	UpperCase L 81EK W/KB IG FP BL BU	5CB0R08796	
2	UpperCase L 81EK W/KB IGFPBL CZ-SK	5CB0R08756	
2	UpperCase L 81EK W/KB IG FP BL BZ	5CB0R08910	
2	UpperCase L 81EK W/KB IGFPBL AR-FR	5CB0R08682	
2	UpperCase L 81EK W/KB IG FP BL USA	5CB0R08815	
2	UpperCase L 81EK W/KB IG FP BL US	5CB0R08514	
2	UpperCase L 81EK W/KB IG FP NBL GK	5CB0R08526	
2	UpperCase L 81EK W/KB IG FP NBL UI	5CB0R08466	
2	UpperCase L 81EK W/KB IG FP NBL KO	5CB0R08768	
2	UpperCase L 81EK W/KB IG FP NBL CH	5CB0R08782	
2	UpperCase L 81EK W/KB IG FP NBL RU	5CB0R08617	
2	UpperCase L 81EK W/KB IGFPNBL AR-E	5CB0R08748	
2	UpperCase L 81EK W/KB IG FP NBL HB	5CB0R08687	
2	UpperCase L 81EK W/KB IG FP NBL TI	5CB0R08652	
2	UpperCase L 81EK W/KBIGFPNBL INDIA	5CB0R08624	
2	UpperCase L 81EK W/KB IG FP NBL UA	5CB0R08619	
2	UpperCase L 81EK W/KB IG FP NBL UK	5CB0R08818	
2	UpperCase L 81EK W/KB IG FP NBL IT	5CB0R08810	

Table 4. Parts list—Overall (continued)

No.	FRU	FRU no.	CRU ID.
2	UpperCase L 81EK W/KB IG FP NBL SP	5CB0R08477	N
2	UpperCase L 81EK W/KB IG FP NBL TR	5CB0R08865	
2	UpperCase L 81EK W/KB IG FP NBL PO	5CB0R08590	
2	UpperCase L 81EK W/KB IG FP NBL LA	5CB0R08542	
2	UpperCase L 81EK W/KB IGFPNBL CF-E	5CB0R08763	
2	UpperCase L 81EK W/KB IG FP NBL ND	5CB0R08791	
2	UpperCase L 81EK W/KB IG FP NBL FR	5CB0R08861	
2	UpperCase L 81EK W/KB IG FP NBL GR	5CB0R08887	
2	UpperCase L 81EK W/KB IG FP NBL NL	5CB0R08726	
2	UpperCase L 81EK W/KB IG FP NBL HG	5CB0R08873	
2	UpperCase L 81EK W/KB IG FP NBL BE	5CB0R08802	
2	UpperCase L 81EK W/KB IG FPNBL ICE	5CB0R08492	
2	UpperCase L 81EK W/KB IG FP NBL SA	5CB0R08758	
2	UpperCase L 81EK W/KB IG FP NBL SW	5CB0R08622	
2	UpperCase L 81EK W/KB IG FP NBL BU	5CB0R08801	
2	UpperCase L 81EK W/KBIGFPNBL CZ-SK	5CB0R08866	
2	UpperCase L 81EK W/KB IG FP NBL BZ	5CB0R08479	
2	UpperCase L 81EK W/KBIGFPNBL AR-FR	5CB0R08706	
2	UpperCase L 81EK W/KB IG FP NBL US	5CB0R08472	
2	UpperCase L 81EK W/KB IG NFP BL GK	5CB0R08834	
2	UpperCase L 81EK W/KB IG NFP BL UI	5CB0R08899	
2	UpperCase L 81EK W/KB IG NFP BL KO	5CB0R08759	
2	UpperCase L 81EK W/KB IG NFP BL CH	5CB0R08593	
2	UpperCase L 81EK W/KB IG NFP BL RU	5CB0R08850	
2	UpperCase L 81EK W/KB IG NFPBL AR-E	5CB0R08658	
2	UpperCase L 81EK W/KB IG NFP BL HB	5CB0R08587	
2	UpperCase L 81EK W/KB IG NFP BL TI	5CB0R08534	
2	UpperCase L 81EK W/KBIGNFPBL INDIA	5CB0R08727	
2	UpperCase L 81EK W/KB IG NFP BL UA	5CB0R08771	
2	UpperCase L 81EK W/KB IG NFP BL UK	5CB0R08908	
2	UpperCase L 81EK W/KB IG NFP BL IT	5CB0R08607	
2	UpperCase L 81EK W/KB IG NFP BL SP	5CB0R08724	
2	UpperCase L 81EK W/KB IG NFP BL TR	5CB0R08797	
2	UpperCase L 81EK W/KB IG NFP BL PO	5CB0R08550	
2	UpperCase L 81EK W/KB IG NFP BL LA	5CB0R08552	
2	UpperCase L 81EK W/KB IG NFPBL CF-E	5CB0R08882	
2	UpperCase L 81EK W/KB IG NFP BL ND	5CB0R08667	
2	UpperCase L 81EK W/KB IG NFP BL FR	5CB0R08811	
2	UpperCase L 81EK W/KB IG NFP BL GR	5CB0R08842	
2	UpperCase L 81EK W/KB IG NFP BL NL	5CB0R08523	
2	UpperCase L 81EK W/KB IG NFP BL HG	5CB0R08857	
2	UpperCase L 81EK W/KB IG NFP BL BE	5CB0R08806	
2	UpperCase L 81EK W/KB IG NFPBL ICE	5CB0R08563	
2	UpperCase L 81EK W/KB IG NFP BL SA	5CB0R08613	
2	UpperCase L 81EK W/KB IG NFP BL SW	5CB0R08620	
2	UpperCase L 81EK W/KB IG NFP BL BU	5CB0R08581	

Table 4. Parts list—Overall (continued)

No.	FRU	FRU no.	CRU ID.
2	UpperCase L 81EK W/KBIGNFPBL CZ-SK	5CB0R08694	N
2	UpperCase L 81EK W/KB IG NFP BL BZ	5CB0R08522	
2	UpperCase L 81EK W/KBIGNFPBL AR-FR	5CB0R08808	
2	UpperCase L 81EK W/KB IG NFPBL USA	5CB0R08625	
2	UpperCase L 81EK W/KB IG NFP BL US	5CB0R08863	
2	UpperCase L 81EK W/KB IG NFPNBL GK	5CB0R08869	
2	UpperCase L 81EK W/KB IG NFPNBL UI	5CB0R08584	
2	UpperCase L 81EK W/KB IG NFPNBL KO	5CB0R08721	
2	UpperCase L 81EK W/KB IG NFPNBL CH	5CB0R08832	
2	UpperCase L 81EK W/KB IG NFPNBL RU	5CB0R08837	
2	UpperCase L 81EK W/KBIGNFPNBL AR-E	5CB0R08543	
2	UpperCase L 81EK W/KB IG NFPNBL HB	5CB0R08646	
2	UpperCase L 81EK W/KB IG NFPNBL TI	5CB0R08906	
2	UpperCase L 81EKW/KBIGNFPNBL INDIA	5CB0R08684	
2	UpperCase L 81EK W/KB IG NFPNBL UA	5CB0R08509	
2	UpperCase L 81EK W/KB IG NFPNBL UK	5CB0R08776	
2	UpperCase L 81EK W/KB IG NFPNBL IT	5CB0R08841	
2	UpperCase L 81EK W/KB IG NFPNBL SP	5CB0R08608	
2	UpperCase L 81EK W/KB IG NFPNBL TR	5CB0R08824	
2	UpperCase L 81EK W/KB IG NFPNBL PO	5CB0R08532	
2	UpperCase L 81EK W/KB IG NFPNBL LA	5CB0R08872	
2	UpperCase L 81EK W/KBIGNFPNBL CF-E	5CB0R08847	
2	UpperCase L 81EK W/KB IG NFPNBL ND	5CB0R08626	
2	UpperCase L 81EK W/KB IG NFPNBL FR	5CB0R08673	
2	UpperCase L 81EK W/KB IG NFPNBL GR	5CB0R08480	
2	UpperCase L 81EK W/KB IG NFPNBL NL	5CB0R08578	
2	UpperCase L 81EK W/KB IG NFPNBL HG	5CB0R08547	
2	UpperCase L 81EK W/KB IG NFPNBL BE	5CB0R08489	
2	UpperCase L 81EK W/KB IG NFPNBL ICE	5CB0R08817	
2	UpperCase L 81EK W/KB IG NFPNBL SA	5CB0R08555	
2	UpperCase L 81EK W/KB IG NFPNBL SW	5CB0R08586	
2	UpperCase L 81EK W/KB IG NFPNBL BU	5CB0R08789	
2	UpperCase L 81EKW/KBIGNFPNBL CZ-SK	5CB0R08611	
2	UpperCase L 81EK W/KB IG NFPNBL BZ	5CB0R08696	
2	UpperCase L 81EKW/KBIGNFPNBL AR-FR	5CB0R08485	
2	UpperCase L 81EK W/KB IG NFPNBL US	5CB0R08747	
2	UpperCase L 81EK W/KB PTN FP BL GK	5CB0R08742	
2	UpperCase L 81EK W/KB PTN FP BL UI	5CB0R08722	
2	UpperCase L 81EK W/KB PTN FP BL KO	5CB0R08527	
2	UpperCase L 81EK W/KB PTN FP BL CH	5CB0R08467	
2	UpperCase L 81EK W/KB PTN FP BL RU	5CB0R08606	
2	UpperCase L 81EKW/KB PTN FPBL AR-E	5CB0R08807	
2	UpperCase L 81EK W/KB PTN FP BL HB	5CB0R08867	
2	UpperCase L 81EK W/KB PTN FP BL TI	5CB0R08864	
2	UpperCase L 81EKW/KB PTNFPBL INDIA	5CB0R08645	
2	UpperCase L 81EK W/KB PTN FP BL UA	5CB0R08602	

Table 4. Parts list—Overall (continued)

No.	FRU	FRU no.	CRU ID.
2	UpperCase L 81EK W/KB PTN FP BL UK	5CB0R08907	N
2	UpperCase L 81EK W/KB PTN FP BL IT	5CB0R08805	
2	UpperCase L 81EK W/KB PTN FP BL SP	5CB0R08636	
2	UpperCase L 81EK W/KB PTN FP BL TR	5CB0R08649	
2	UpperCase L 81EK W/KB PTN FP BL PO	5CB0R08760	
2	UpperCase L 81EK W/KB PTN FP BL LA	5CB0R08904	
2	UpperCase L 81EKW/KB PTN FPBL CF-E	5CB0R08753	
2	UpperCase L 81EK W/KB PTN FP BL ND	5CB0R08478	
2	UpperCase L 81EK W/KB PTN FP BL FR	5CB0R08902	
2	UpperCase L 81EK W/KB PTN FP BL GR	5CB0R08674	
2	UpperCase L 81EK W/KB PTN FP BL NL	5CB0R08830	
2	UpperCase L 81EK W/KB PTN FP BL HG	5CB0R08725	
2	UpperCase L 81EK W/KB PTN FP BL BE	5CB0R08717	
2	UpperCase L 81EKW/KB PTN FP BL ICE	5CB0R08517	
2	UpperCase L 81EK W/KB PTN FP BL SA	5CB0R08469	
2	UpperCase L 81EK W/KB PTN FP BL SW	5CB0R08780	
2	UpperCase L 81EK W/KB PTN FP BL BU	5CB0R08678	
2	UpperCase L 81EKW/KB PTNFPBL CZ-SK	5CB0R08735	
2	UpperCase L 81EK W/KB PTN FP BL BZ	5CB0R08571	
2	UpperCase L 81EKW/KB PTNFPBL AR-FR	5CB0R08481	
2	UpperCase L 81EKW/KB PTN FP BL USA	5CB0R08890	
2	UpperCase L 81EK W/KB PTN FP BL US	5CB0R08901	
2	UpperCase L 81EKW/KB PTN FP NBL GK	5CB0R08718	
2	UpperCase L 81EKW/KB PTN FP NBL UI	5CB0R08701	
2	UpperCase L 81EKW/KB PTN FP NBL KO	5CB0R08828	
2	UpperCase L 81EKW/KB PTN FP NBL CH	5CB0R08630	
2	UpperCase L 81EKW/KB PTN FP NBL RU	5CB0R08785	
2	UpperCase L 81EKW/KB PTNFPNBL AR-E	5CB0R08883	
2	UpperCase L 81EKW/KB PTN FP NBL HB	5CB0R08623	
2	UpperCase L 81EKW/KB PTN FP NBL TI	5CB0R08854	
2	UpperCase L 81EKW/KBPTNFPNBL INDIA	5CB0R08529	
2	UpperCase L 81EKW/KB PTN FP NBL UA	5CB0R08524	
2	UpperCase L 81EKW/KB PTN FP NBL UK	5CB0R08656	
2	UpperCase L 81EKW/KB PTN FP NBL IT	5CB0R08545	
2	UpperCase L 81EKW/KB PTN FP NBL SP	5CB0R08499	
2	UpperCase L 81EKW/KB PTN FP NBL TR	5CB0R08821	
2	UpperCase L 81EKW/KB PTN FP NBL PO	5CB0R08487	
2	UpperCase L 81EKW/KB PTN FP NBL LA	5CB0R08764	
2	UpperCase L 81EKW/KB PTNFPNBL CF-E	5CB0R08609	
2	UpperCase L 81EKW/KB PTN FP NBL ND	5CB0R08554	
2	UpperCase L 81EKW/KB PTN FP NBL FR	5CB0R08812	
2	UpperCase L 81EKW/KB PTN FP NBL GR	5CB0R08905	
2	UpperCase L 81EKW/KB PTN FP NBL NL	5CB0R08731	
2	UpperCase L 81EKW/KB PTN FP NBL HG	5CB0R08464	
2	UpperCase L 81EKW/KB PTN FP NBL BE	5CB0R08826	
2	UpperCase L 81EKW/KB PTN FPNBL ICE	5CB0R08737	

Table 4. Parts list—Overall (continued)

No.	FRU	FRU no.	CRU ID.
2	UpperCase L 81EKW/KB PTN FP NBL SA	5CB0R08757	N
2	UpperCase L 81EKW/KB PTN FP NBL SW	5CB0R08892	
2	UpperCase L 81EKW/KB PTN FP NBL BU	5CB0R08650	
2	UpperCase L 81EKW/KBPTNFPNBL CZ-SK	5CB0R08792	
2	UpperCase L 81EKW/KB PTN FP NBL BZ	5CB0R08702	
2	UpperCase L 81EKW/KBPTNFPNBL AR-FR	5CB0R08572	
2	UpperCase L 81EKW/KB PTN FP NBL US	5CB0R08885	
2	UpperCase L 81EKW/KB PTN NFP BL GK	5CB0R08853	
2	UpperCase L 81EKW/KB PTN NFP BL UI	5CB0R08559	
2	UpperCase L 81EKW/KB PTN NFP BL KO	5CB0R08715	
2	UpperCase L 81EKW/KB PTN NFP BL CH	5CB0R08471	
2	UpperCase L 81EKW/KB PTN NFP BL RU	5CB0R08565	
2	UpperCase L 81EKW/KB PTNNFPBL AR-E	5CB0R08740	
2	UpperCase L 81EKW/KB PTN NFP BL HB	5CB0R08677	
2	UpperCase L 81EKW/KB PTN NFP BL TI	5CB0R08605	
2	UpperCase L 81EKW/KBPTNNFPBL INDIA	5CB0R08804	
2	UpperCase L 81EKW/KB PTN NFP BL UA	5CB0R08640	
2	UpperCase L 81EKW/KB PTN NFP BL UK	5CB0R08743	
2	UpperCase L 81EKW/KB PTN NFP BL IT	5CB0R08497	
2	UpperCase L 81EKW/KB PTN NFP BL SP	5CB0R08870	
2	UpperCase L 81EKW/KB PTN NFP BL TR	5CB0R08579	
2	UpperCase L 81EKW/KB PTN NFP BL PO	5CB0R08562	
2	UpperCase L 81EKW/KB PTN NFP BL LA	5CB0R08531	
2	UpperCase L 81EKW/KB PTNNFPBL CF-E	5CB0R08657	
2	UpperCase L 81EKW/KB PTN NFP BL ND	5CB0R08651	
2	UpperCase L 81EKW/KB PTN NFP BL FR	5CB0R08784	
2	UpperCase L 81EKW/KB PTN NFP BL GR	5CB0R08544	
2	UpperCase L 81EKW/KB PTN NFP BL NL	5CB0R08558	
2	UpperCase L 81EKW/KB PTN NFP BL HG	5CB0R08465	
2	UpperCase L 81EKW/KB PTN NFP BL BE	5CB0R08484	
2	UpperCase L 81EKW/KB PTN NFPBL ICE	5CB0R08858	
2	UpperCase L 81EKW/KB PTN NFP BL SA	5CB0R08816	
2	UpperCase L 81EKW/KB PTN NFP BL SW	5CB0R08860	
2	UpperCase L 81EKW/KB PTN NFP BL BU	5CB0R08900	
2	UpperCase L 81EKW/KBPTNNFPBL CZ-SK	5CB0R08591	
2	UpperCase L 81EKW/KB PTN NFP BL BZ	5CB0R08838	
2	UpperCase L 81EKW/KBPTNNFPBL AR-FR	5CB0R08897	
2	UpperCase L 81EKW/KB PTN NFPBL USA	5CB0R08594	
2	UpperCase L 81EKW/KB PTN NFP BL US	5CB0R08660	
2	UpperCase L 81EKW/KB PTN NFPNBL GK	5CB0R08643	
2	UpperCase L 81EKW/KB PTN NFPNBL UI	5CB0R08695	
2	UpperCase L 81EKW/KB PTN NFPNBL KO	5CB0R08855	
2	UpperCase L 81EKW/KB PTN NFPNBL CH	5CB0R08772	
2	UpperCase L 81EKW/KB PTN NFPNBL RU	5CB0R08788	
2	UpperCase L 81EKW/KBPTNNFPNBL AR-E	5CB0R08601	
2	UpperCase L 81EKW/KB PTN NFPNBL HB	5CB0R08886	
2	UpperCase L 81EKW/KB PTN NFPNBL TI	5CB0R08490	

No.	FRU	FRU no.	CRU ID.
2	UpperCase L 81EKW/KBPTNNFPNBL INDIA	5CB0R08665	N
2	UpperCase L 81EKW/KB PTN NFPNBL UA	5CB0R08884	
2	UpperCase L 81EKW/KB PTN NFPNBL UK	5CB0R08843	
2	UpperCase L 81EKW/KB PTN NFPNBL IT	5CB0R08871	
2	UpperCase L 81EKW/KB PTN NFPNBL SP	5CB0R08880	
2	UpperCase L 81EKW/KB PTN NFPNBL TR	5CB0R08473	
2	UpperCase L 81EKW/KB PTN NFPNBL PO	5CB0R08691	
2	UpperCase L 81EKW/KB PTN NFPNBL LA	5CB0R08895	
2	UpperCase L 81EKW/KBPTNNFPNBL CF-E	5CB0R08794	
2	UpperCase L 81EKW/KB PTN NFPNBL ND	5CB0R08641	
2	UpperCase L 81EKW/KB PTN NFPNBL FR	5CB0R08773	
2	UpperCase L 81EKW/KB PTN NFPNBL GR	5CB0R08588	
2	UpperCase L 81EKW/KB PTN NFPNBL NL	5CB0R08521	
2	UpperCase L 81EKW/KB PTN NFPNBL HG	5CB0R08518	
2	UpperCase L 81EKW/KB PTN NFPNBL BE	5CB0R08809	
2	UpperCase L 81EKW/KB PTNNFPNBL ICE	5CB0R08528	
2	UpperCase L 81EKW/KB PTN NFPNBL SA	5CB0R08891	
2	UpperCase L 81EKW/KB PTN NFPNBL SW	5CB0R08576	
2	UpperCase L 81EKW/KB PTN NFPNBL BU	5CB0R08716	
2	UpperCaseL 81EKW/KBPTNNFPNBL CZ-SK	5CB0R08486	
2	UpperCase L 81EKW/KB PTN NFPNBL BZ	5CB0R08755	
2	UpperCaseL 81EKW/KBPTNNFPNBL AR-FR	5CB0R08519	
2	UpperCase L 81EKW/KB PTN NFPNBL US	5CB0R08539	
2	UpperCase L 81EK W/KB LB FP BL GK	5CB0R08769	
2	UpperCase L 81EK W/KB LB FP BL UI	5CB0R08846	
2	UpperCase L 81EK W/KB LB FP BL KO	5CB0R08738	
2	UpperCase L 81EK W/KB LB FP BL CH	5CB0R08692	
2	UpperCase L 81EK W/KB LB FP BL RU	5CB0R08501	
2	UpperCase L 81EK W/KB LB FPBL AR-E	5CB0R08508	
2	UpperCase L 81EK W/KB LB FP BL HB	5CB0R08879	
2	UpperCase L 81EK W/KB LB FP BL TI	5CB0R08627	
2	UpperCase L 81EK W/KB LBF PBL INDIA	5CB0R08592	
2	UpperCase L 81EK W/KB LB FP BL UA	5CB0R08676	
2	UpperCase L 81EK W/KB LB FP BL UK	5CB0R08889	
2	UpperCase L 81EK W/KB LB FP BL IT	5CB0R08745	
2	UpperCase L 81EK W/KB LB FP BL SP	5CB0R08540	
2	UpperCase L 81EK W/KB LB FP BL TR	5CB0R08546	
2	UpperCase L 81EK W/KB LB FP BL PO	5CB0R08893	
2	UpperCase L 81EK W/KB LB FP BL LA	5CB0R08585	
2	UpperCase L 81EK W/KB LB FPBL CF-E	5CB0R08566	
2	UpperCase L 81EK W/KB LB FP BL ND	5CB0R08770	
2	UpperCase L 81EK W/KB LB FP BL FR	5CB0R08533	
2	UpperCase L 81EK W/KB LB FP BL GR	5CB0R08474	
2	UpperCase L 81EK W/KB LB FP BL NL	5CB0R08839	
2	UpperCase L 81EK W/KB LB FP BL HG	5CB0R08664	
2	UpperCase L 81EK W/KB LB FP BL BE	5CB0R08733	
2	UpperCase L 81EK W/KB LB FP BL ICE	5CB0R08575	
2	UpperCase L 81EK W/KB LB FP BL SA	5CB0R08493	

No.	FRU	FRU no.	CRU ID.
2	UpperCase L 81EK W/KB LB FP BL SW	5CB0R08500	N
2	UpperCase L 81EK W/KB LB FP BL BU	5CB0R08637	
2	UpperCase L 81EK W/KB LBFPL CZ-SK	5CB0R08848	
2	UpperCase L 81EK W/KB LB FP BL BZ	5CB0R08496	
2	UpperCase L 81EK W/KB LBFPL AR-FR	5CB0R08825	
2	UpperCase L 81EK W/KB LB FP BL USA	5CB0R08874	
2	UpperCase L 81EK W/KB LB FP BL US	5CB0R08698	
2	UpperCase L 81EK W/KB LB FP NBL GK	5CB0R08515	
2	UpperCase L 81EK W/KB LB FP NBL UI	5CB0R08615	
2	UpperCase L 81EK W/KB LB FP NBL KO	5CB0R08898	
2	UpperCase L 81EK W/KB LB FP NBL CH	5CB0R08766	
2	UpperCase L 81EK W/KB LB FP NBL RU	5CB0R08822	
2	UpperCase L 81EK W/KB LBFNBL AR-E	5CB0R08612	
2	UpperCase L 81EK W/KB LB FP NBL HB	5CB0R08814	
2	UpperCase L 81EK W/KB LB FP NBL TI	5CB0R08506	
2	UpperCase L 81EK W/KBLBFNBL INDIA	5CB0R08570	
2	UpperCase L 81EK W/KB LB FP NBL UA	5CB0R08699	
2	UpperCase L 81EK W/KB LB FP NBL UK	5CB0R08752	
2	UpperCase L 81EK W/KB LB FP NBL IT	5CB0R08560	
2	UpperCase L 81EK W/KB LB FP NBL SP	5CB0R08680	
2	UpperCase L 81EK W/KB LB FP NBL TR	5CB0R08833	
2	UpperCase L 81EK W/KB LB FP NBL PO	5CB0R08754	
2	UpperCase L 81EK W/KB LB FP NBL LA	5CB0R08856	
2	UpperCase L 81EK W/KB LBFNBL CF-E	5CB0R08538	
2	UpperCase L 81EK W/KB LB FP NBL ND	5CB0R08556	
2	UpperCase L 81EK W/KB LB FP NBL FR	5CB0R08648	
2	UpperCase L 81EK W/KB LB FP NBL GR	5CB0R08681	
2	UpperCase L 81EK W/KB LB FP NBL NL	5CB0R08686	
2	UpperCase L 81EK W/KB LB FP NBL HG	5CB0R08840	
2	UpperCase L 81EK W/KB LB FP NBL BE	5CB0R08703	
2	UpperCase L 81EK W/KB LB FPNBL ICE	5CB0R08568	
2	UpperCase L 81EK W/KB LB FP NBL SA	5CB0R08666	
2	UpperCase L 81EK W/KB LB FP NBL SW	5CB0R08896	
2	UpperCase L 81EK W/KB LB FP NBL BU	5CB0R08765	
2	UpperCase L 81EK W/KBLBFNBL CZ-SK	5CB0R08730	
2	UpperCase L 81EK W/KB LB FP NBL BZ	5CB0R08736	
2	UpperCase L 81EK W/KBLBFNBL AR-FR	5CB0R08704	
2	UpperCase L 81EK W/KB LB FP NBL US	5CB0R08876	
2	UpperCase L 81EK W/KB LB NFP BL GK	5CB0R08569	
2	UpperCase L 81EK W/KB LB NFP BL UI	5CB0R08502	
2	UpperCase L 81EK W/KB LB NFP BL KO	5CB0R08713	
2	UpperCase L 81EK W/KB LB NFP BL CH	5CB0R08616	
2	UpperCase L 81EK W/KB LB NFP BL RU	5CB0R08507	
2	UpperCase L 81EK W/KB LBNFPBL AR-E	5CB0R08710	
2	UpperCase L 81EK W/KB LB NFP BL HB	5CB0R08561	
2	UpperCase L 81EK W/KB LB NFP BL TI	5CB0R08629	
2	UpperCase L 81EK W/KBLBNFPBL INDIA	5CB0R08683	
2	UpperCase L 81EK W/KB LB NFP BL UA	5CB0R08535	

No.	FRU	FRU no.	CRU ID.
2	UpperCase L 81EK W/KB LB NFP BL UK	5CB0R08504	N
2	UpperCase L 81EK W/KB LB NFP BL IT	5CB0R08849	
2	UpperCase L 81EK W/KB LB NFP BL SP	5CB0R08823	
2	UpperCase L 81EK W/KB LB NFP BL TR	5CB0R08580	
2	UpperCase L 81EK W/KB LB NFP BL PO	5CB0R08513	
2	UpperCase L 81EK W/KB LB NFP BL LA	5CB0R08707	
2	UpperCase L 81EK W/KB LBNFPBL CF-E	5CB0R08700	
2	UpperCase L 81EK W/KB LB NFP BL ND	5CB0R08859	
2	UpperCase L 81EK W/KB LB NFP BL FR	5CB0R08688	
2	UpperCase L 81EK W/KB LB NFP BL GR	5CB0R08510	
2	UpperCase L 81EK W/KB LB NFP BL NL	5CB0R08705	
2	UpperCase L 81EK W/KB LB NFP BL HG	5CB0R08749	
2	UpperCase L 81EK W/KB LB NFP BL BE	5CB0R08829	
2	UpperCase L 81EK W/KB LB NFPBL ICE	5CB0R08642	
2	UpperCase L 81EK W/KB LB NFP BL SA	5CB0R08659	
2	UpperCase L 81EK W/KB LB NFP BL SW	5CB0R08669	
2	UpperCase L 81EK W/KB LB NFP BL BU	5CB0R08803	
2	UpperCase L 81EK W/KBLBNFPBL CZ-SK	5CB0R08599	
2	UpperCase L 81EK W/KB LB NFP BL BZ	5CB0R08614	
2	UpperCase L 81EK W/KBLBNFPBL AR-FR	5CB0R08567	
2	UpperCase L 81EK W/KB LB NFPBL USA	5CB0R08503	
2	UpperCase L 81EK W/KB LB NFP BL US	5CB0R08628	
2	UpperCase L 81EK W/KB LB NFPNBL GK	5CB0R08536	
2	UpperCase L 81EK W/KB LB NFPNBL UI	5CB0R08661	
2	UpperCase L 81EK W/KB LB NFPNBL KO	5CB0R08851	
2	UpperCase L 81EK W/KB LB NFPNBL CH	5CB0R08790	
2	UpperCase L 81EK W/KB LB NFPNBL RU	5CB0R08762	
2	UpperCase L 81EK W/KBLBNFPNBL AR-E	5CB0R08463	
2	UpperCase L 81EK W/KB LB NFPNBL HB	5CB0R08498	
2	UpperCase L 81EK W/KB LB NFPNBL TI	5CB0R08475	
2	UpperCase L 81EKW/KBLBNFPNBL INDIA	5CB0R08573	
2	UpperCase L 81EK W/KB LB NFPNBL UA	5CB0R08728	
2	UpperCase L 81EK W/KB LB NFPNBL UK	5CB0R08633	
2	UpperCase L 81EK W/KB LB NFPNBL IT	5CB0R08697	
2	UpperCase L 81EK W/KB LB NFPNBL SP	5CB0R08750	
2	UpperCase L 81EK W/KB LB NFPNBL TR	5CB0R08577	
2	UpperCase L 81EK W/KB LB NFPNBL PO	5CB0R08662	
2	UpperCase L 81EK W/KB LB NFPNBL LA	5CB0R08548	
2	UpperCase L 81EK W/KBLBNFPNBL CF-E	5CB0R08881	
2	UpperCase L 81EK W/KB LB NFPNBL ND	5CB0R08690	
2	UpperCase L 81EK W/KB LB NFPNBL FR	5CB0R08541	
2	UpperCase L 81EK W/KB LB NFPNBL GR	5CB0R08557	
2	UpperCase L 81EK W/KB LB NFPNBL NL	5CB0R08494	
2	UpperCase L 81EK W/KB LB NFPNBL HG	5CB0R08862	
2	UpperCase L 81EK W/KB LB NFPNBL BE	5CB0R08600	
2	UpperCase L 81EK W/KB LBNFPNBL ICE	5CB0R08634	
2	UpperCase L 81EK W/KB LB NFPNBL SA	5CB0R08631	
2	UpperCase L 81EK W/KB LB NFPNBL SW	5CB0R08635	

No.	FRU	FRU no.	CRU ID.
2	UpperCase L 81EK W/KB LB NFPNBL BU	5CB0R08672	N
2	UpperCase L 81EKW/KBLBNFPNBL CZ-SK	5CB0R08786	
2	UpperCase L 81EK W/KB LB NFPNBL BZ	5CB0R08781	
2	UpperCase L 81EKW/KBLBNFPNBL AR-FR	5CB0R08603	
2	UpperCase L 81EK W/KB LB NFPNBL US	5CB0R08845	
2	US80KeyPD4SBChiconyGreyKBacklightKB	SN20Q40627	
2	US80KeyPD4SBChiconyGreyKBacklightKB-forUSA	SN20Q40688	
2	UK81KeyPD4SBChiconyGreyKBacklightKB	SN20Q40631	
2	Italian81KeyPD4SBChiconyGreyKBacklightKB	SN20Q40637	
2	Spanish81KeyPD4SBChiconyGreyKBacklightKB	SN20Q40728	
2	Turkish81KeyPD4SBChiconyGreyKBacklightKB	SN20Q40781	
2	Thailand80KeyPD4SBChiconyGreyKBacklightKB	SN20Q40601	
2	Portugue81KeyPD4SBChiconyGreyKBacklightKB	SN20Q40623	
2	LatinSpa81KeyPD4SBChiconyGreyKBacklightKB	SN20Q40606	
2	CanadFrEn81KeyPD4SBChiconyGreyKBacklightKB	SN20Q40840	
2	Korean80KeyPD4SBChiconyGreyKBacklightKB	SN20Q40665	
2	TradChine80KeyPD4SBChiconyGreyKBacklightKB	SN20Q40710	
2	Russian80KeyPD4SBChiconyGreyKBacklightKB	SN20Q40844	
2	French81KeyPD4SBChiconyGreyKBacklightKB	SN20Q40643	
2	German81KeyPD4SBChiconyGreyKBacklightKB	SN20Q40788	
2	Arabic80KeyPD4SBChiconyGreyKBacklightKB	SN20Q40666	
2	Brazilian81KeyPD4SBChiconyGreyKBacklightKB	SN20Q40744	
2	Dutch81KeyPD4SBChiconyGreyKBacklightKB	SN20Q40823	
2	Greek80KeyPD4SBChiconyGreyKBacklightKB	SN20Q40676	
2	Hebrew80KeyPD4SBChiconyGreyKBacklightKB	SN20Q40633	
2	Hungarian81KeyPD4SBChiconyGreyKBacklightKB	SN20Q40745	
2	Nordic81KeyPD4SBChiconyGreyKBacklightKB	SN20Q40797	
2	Belgian81KeyPD4SBChiconyGreyKBacklightKB	SN20Q40675	
2	Iceland81KeyPD4SBChiconyGreyKBacklightKB	SN20Q40842	
2	Slovenian81KeyPD4SBChiconyGreyKBacklightKB	SN20Q40771	
2	Swiss81KeyPD4SBChiconyGreyKBacklightKB	SN20Q40766	
2	USInter80KeyPD4SBChiconyGreyKBacklightKB	SN20Q40650	
2	Czh-Slk81KeyPD4SBChiconyGreyKBacklightKB	SN20Q40834	
2	Bulgarian81KeyPD4SBChiconyGreyKBacklightKB	SN20Q40671	
2	India80KeyPD4SBChiconyGreyKBacklightKB	SN20Q40702	
2	French-Arabic81KeyPD4SBChiconyGreyKBacklightKB	SN20Q40602	
2	Ukrainia80keyPD4SBChiconyGreyKBacklightKB	SN20Q40790	
2	US80KeyPD4SBLiteonGreyKBacklightKB	SN20Q40730	
2	US80KeyPD4SBLiteonGreyKBacklightKB-forUSA	SN20Q40674	
2	UK81KeyPD4SBLiteonGreyKBacklightKB	SN20Q40663	
2	Italian81KeyPD4SBLiteonGreyKBacklightKB	SN20Q40703	
2	Spanish81KeyPD4SBLiteonGreyKBacklightKB	SN20Q40750	
2	Turkish81KeyPD4SBLiteonGreyKBacklightKB	SN20Q40798	
2	Thailand80KeyPD4SBLiteonGreyKBacklightKB	SN20Q40704	
2	Portugue81KeyPD4SBLiteonGreyKBacklightKB	SN20Q40698	
2	LatinSpa81KeyPD4SBLiteonGreyKBacklightKB	SN20Q40765	
2	CanadFrEn81KeyPD4SBLiteonGreyKBacklightKB	SN20Q40811	
2	Korean80KeyPD4SBLiteonGreyKBacklightKB	SN20Q40784	

No.	FRU	FRU no.	CRU ID.
2	TradChine80KeyPD4SBLiteonGreyKBacklightKB	SN20Q40735	N
2	Russian80KeyPD4SBLiteonGreyKBacklightKB	SN20Q40616	
2	French81KeyPD4SBLiteonGreyKBacklightKB	SN20Q40810	
2	German81KeyPD4SBLiteonGreyKBacklightKB	SN20Q40661	
2	Arabic80KeyPD4SBLiteonGreyKBacklightKB	SN20Q40628	
2	Brazilian81KeyPD4SBLiteonGreyKBacklightKB	SN20Q40659	
2	Dutch81KeyPD4SBLiteonGreyKBacklightKB	SN20Q40668	
2	Greek80KeyPD4SBLiteonGreyKBacklightKB	SN20Q40670	
2	Hebrew80KeyPD4SBLiteonGreyKBacklightKB	SN20Q40680	
2	Hungarian81KeyPD4SBLiteonGreyKBacklightKB	SN20Q40635	
2	Nordic81KeyPD4SBLiteonGreyKBacklightKB	SN20Q40763	
2	Belgian81KeyPD4SBLiteonGreyKBacklightKB	SN20Q40619	
2	Iceland81KeyPD4SBLiteonGreyKBacklightKB	SN20Q40736	
2	Slovenian81KeyPD4SBLiteonGreyKBacklightKB	SN20Q40792	
2	Swiss81KeyPD4SBLiteonGreyKBacklightKB	SN20Q40645	
2	USInter80KeyPD4SBLiteonGreyKBacklightKB	SN20Q40733	
2	Czh-Slk81KeyPD4SBLiteonGreyKBacklightKB	SN20Q40593	
2	Bulgarian81KeyPD4SBLiteonGreyKBacklightKB	SN20Q40644	
2	India80KeyPD4SBLiteonGreyKBacklightKB	SN20Q40828	
2	French-Arabic81KeyPD4SBLiteonGreyKBacklightKB	SN20Q40806	
2	Ukraine80keyPD4SBLiteonGreyKBacklightKB	SN20Q40841	
2	US80KeyPD4SBDarfonGreyKBacklightKB	SN20Q40624	
2	US80KeyPD4SBDarfonGreyKBacklightKB-forUSA	SN20Q40700	
2	UK81KeyPD4SBDarfonGreyKBacklightKB	SN20Q40839	
2	Italian81KeyPD4SBDarfonGreyKBacklightKB	SN20Q40819	
2	Spanish81KeyPD4SBDarfonGreyKBacklightKB	SN20Q40632	
2	Turkish81KeyPD4SBDarfonGreyKBacklightKB	SN20Q40693	
2	Thailand80KeyPD4SBDarfonGreyKBacklightKB	SN20Q40595	
2	Portugue81KeyPD4SBDarfonGreyKBacklightKB	SN20Q40845	
2	LatinSpa81KeyPD4SBDarfonGreyKBacklightKB	SN20Q40653	
2	CanadFrEn81KeyPD4SBDarfonGreyKBacklightKB	SN20Q40832	
2	Korean80KeyPD4SBDarfonGreyKBacklightKB	SN20Q40687	
2	TradChine80KeyPD4SBDarfonGreyKBacklightKB	SN20Q40802	
2	Russian80KeyPD4SBDarfonGreyKBacklightKB	SN20Q40776	
2	French81KeyPD4SBDarfonGreyKBacklightKB	SN20Q40614	
2	German81KeyPD4SBDarfonGreyKBacklightKB	SN20Q40846	
2	Arabic80KeyPD4SBDarfonGreyKBacklightKB	SN20Q40609	
2	Brazilian81KeyPD4SBDarfonGreyKBacklightKB	SN20Q40639	
2	Dutch81KeyPD4SBDarfonGreyKBacklightKB	SN20Q40768	
2	Greek80KeyPD4SBDarfonGreyKBacklightKB	SN20Q40761	
2	Hebrew80KeyPD4SBDarfonGreyKBacklightKB	SN20Q40762	
2	Hungarian81KeyPD4SBDarfonGreyKBacklightKB	SN20Q40751	
2	Nordic81KeyPD4SBDarfonGreyKBacklightKB	SN20Q40794	
2	Belgian81KeyPD4SBDarfonGreyKBacklightKB	SN20Q40605	
2	Iceland81KeyPD4SBDarfonGreyKBacklightKB	SN20Q40722	
2	Slovenian81KeyPD4SBDarfonGreyKBacklightKB	SN20Q40667	
2	Swiss81KeyPD4SBDarfonGreyKBacklightKB	SN20Q40725	
2	USInter80KeyPD4SBDarfonGreyKBacklightKB	SN20Q40636	

No.	FRU	FRU no.	CRU ID.
2	Czh-Slk81KeyPD4SBDarfonGreyKBacklightKB	SN20Q40599	N
2	Bulgarian81KeyPD4SBDarfonGreyKBacklightKB	SN20Q40677	
2	India80KeyPD4SBDarfonGreyKBacklightKB	SN20Q40603	
2	French-Arabic81KeyPD4SBDarfonGreyKBacklightKB	SN20Q40690	
2	Ukrainia80keyPD4SBSunrexGreyKBacklightKB	SN20Q40612	
2	US80KeyPD4SBSunrexGreyKBacklightKB	SN20Q40714	
2	US80KeyPD4SBSunrexGreyKBacklightKB-forUSA	SN20Q40843	
2	UK81KeyPD4SBSunrexGreyKBacklightKB	SN20Q40596	
2	Italian81KeyPD4SBSunrexGreyKBacklightKB	SN20Q40796	
2	Spanish81KeyPD4SBSunrexGreyKBacklightKB	SN20Q40779	
2	Turkish81KeyPD4SBSunrexGreyKBacklightKB	SN20Q40748	
2	Thailand80KeyPD4SBSunrexGreyKBacklightKB	SN20Q40634	
2	Portugue81KeyPD4SBSunrexGreyKBacklightKB	SN20Q40829	
2	LatinSpa81KeyPD4SBSunrexGreyKBacklightKB	SN20Q40591	
2	CanadFrEn81KeyPD4SBSunrexGreyKBacklightKB	SN20Q40696	
2	Korean80KeyPD4SBSunrexGreyKBacklightKB	SN20Q40692	
2	TradChine80KeyPD4SBSunrexGreyKBacklightKB	SN20Q40618	
2	Russian80KeyPD4SBSunrexGreyKBacklightKB	SN20Q40651	
2	French81KeyPD4SBSunrexGreyKBacklightKB	SN20Q40803	
2	German81KeyPD4SBSunrexGreyKBacklightKB	SN20Q40793	
2	Arabic80KeyPD4SBSunrexGreyKBacklightKB	SN20Q40655	
2	Brazilian81KeyPD4SBSunrexGreyKBacklightKB	SN20Q40772	
2	Dutch81KeyPD4SBSunrexGreyKBacklightKB	SN20Q40814	
2	Greek80KeyPD4SBSunrexGreyKBacklightKB	SN20Q40756	
2	Hebrew80KeyPD4SBSunrexGreyKBacklightKB	SN20Q40607	
2	Hungarian81KeyPD4SBSunrexGreyKBacklightKB	SN20Q40830	
2	Nordic81KeyPD4SBSunrexGreyKBacklightKB	SN20Q40642	
2	Belgian81KeyPD4SBSunrexGreyKBacklightKB	SN20Q40782	
2	Iceland81KeyPD4SBSunrexGreyKBacklightKB	SN20Q40694	
2	Slovenian81KeyPD4SBSunrexGreyKBacklightKB	SN20Q40755	
2	Swiss81KeyPD4SBSunrexGreyKBacklightKB	SN20Q40640	
2	USInter80KeyPD4SBSunrexGreyKBacklightKB	SN20Q40685	
2	Czh-Slk81KeyPD4SBSunrexGreyKBacklightKB	SN20Q40747	
2	Bulgarian81KeyPD4SBSunrexGreyKBacklightKB	SN20Q40835	
2	India80KeyPD4SBSunrexGreyKBacklightKB	SN20Q40804	
2	French-Arabic81KeyPD4SBSunrexGreyKBacklightKB	SN20Q40808	
2	Ukrainia80keyPD4SBSunrexGreyKBacklightKB	SN20Q40646	
2	US80KeyPD4SChiconyGreyKNormalKB	SN20Q40597	
2	UK81KeyPD4SChiconyGreyKNormalKB	SN20Q40615	
2	Italian81KeyPD4SChiconyGreyKNormalKB	SN20Q40625	
2	Spanish81KeyPD4SChiconyGreyKNormalKB	SN20Q40795	
2	Turkish81KeyPD4SChiconyGreyKNormalKB	SN20Q40678	
2	Thailand80KeyPD4SChiconyGreyKNormalKB	SN20Q40610	
2	Portugue81KeyPD4SChiconyGreyKNormalKB	SN20Q40617	
2	LatinSpa81KeyPD4SChiconyGreyKNormalKB	SN20Q40684	
2	CanadFrEn81KeyPD4SChiconyGreyKNormalKB	SN20Q40673	
2	Korean80KeyPD4SChiconyGreyKNormalKB	SN20Q40805	
2	TradChine80KeyPD4SChiconyGreyKNormalKB	SN20Q40723	

No.	FRU	FRU no.	CRU ID.
2	Russian80KeyPD4SChiconyGreyKNormalKB	SN20Q40767	N
2	French81KeyPD4SChiconyGreyKNormalKB	SN20Q40786	
2	German81KeyPD4SChiconyGreyKNormalKB	SN20Q40812	
2	Arabic80KeyPD4SChiconyGreyKNormalKB	SN20Q40711	
2	Brazilian81KeyPD4SChiconyGreyKNormalKB	SN20Q40774	
2	Dutch81KeyPD4SChiconyGreyKNormalKB	SN20Q40836	
2	Greek80KeyPD4SChiconyGreyKNormalKB	SN20Q40778	
2	Hebrew80KeyPD4SChiconyGreyKNormalKB	SN20Q40822	
2	Hungarian81KeyPD4SChiconyGreyKNormalKB	SN20Q40764	
2	Nordic81KeyPD4SChiconyGreyKNormalKB	SN20Q40758	
2	Belgian81KeyPD4SChiconyGreyKNormalKB	SN20Q40589	
2	Iceland81KeyPD4SChiconyGreyKNormalKB	SN20Q40785	
2	Slovenian81KeyPD4SChiconyGreyKNormalKB	SN20Q40697	
2	Swiss81KeyPD4SChiconyGreyKNormalKB	SN20Q40833	
2	USInter80KeyPD4SChiconyGreyKNormalKB	SN20Q40739	
2	Czh-Slk81KeyPD4SChiconyGreyKNormalKB	SN20Q40818	
2	Bulgarian81KeyPD4SChiconyGreyKNormalKB	SN20Q40715	
2	India80KeyPD4SChiconyGreyKNormalKB	SN20Q40734	
2	French-Arabic81KeyPD4SChiconyGreyKNormalKB	SN20Q40707	
2	Ukrainia80keyPD4SChiconyGreyKNormalKB	SN20Q40726	
2	US80KeyPD4SLiteonGreyKNormalKB	SN20Q40820	
2	UK81KeyPD4SLiteonGreyKNormalKB	SN20Q40695	
2	Italian81KeyPD4SLiteonGreyKNormalKB	SN20Q40719	
2	Spanish81KeyPD4SLiteonGreyKNormalKB	SN20Q40654	
2	Turkish81KeyPD4SLiteonGreyKNormalKB	SN20Q40720	
2	Thailand80KeyPD4SLiteonGreyKNormalKB	SN20Q40638	
2	Portugue81KeyPD4SLiteonGreyKNormalKB	SN20Q40706	
2	LatinSpa81KeyPD4SLiteonGreyKNormalKB	SN20Q40669	
2	CanadFrEn81KeyPD4SLiteonGreyKNormalKB	SN20Q40681	
2	Korean80KeyPD4SLiteonGreyKNormalKB	SN20Q40621	
2	TradChine80KeyPD4SLiteonGreyKNormalKB	SN20Q40662	
2	Russian80KeyPD4SLiteonGreyKNormalKB	SN20Q40664	
2	French81KeyPD4SLiteonGreyKNormalKB	SN20Q40815	
2	German81KeyPD4SLiteonGreyKNormalKB	SN20Q40800	
2	Arabic80KeyPD4SLiteonGreyKNormalKB	SN20Q40648	
2	Brazilian81KeyPD4SLiteonGreyKNormalKB	SN20Q40641	
2	Dutch81KeyPD4SLiteonGreyKNormalKB	SN20Q40626	
2	Greek80KeyPD4SLiteonGreyKNormalKB	SN20Q40716	
2	Hebrew80KeyPD4SLiteonGreyKNormalKB	SN20Q40724	
2	Hungarian81KeyPD4SLiteonGreyKNormalKB	SN20Q40699	
2	Nordic81KeyPD4SLiteonGreyKNormalKB	SN20Q40721	
2	Belgian81KeyPD4SLiteonGreyKNormalKB	SN20Q40773	
2	Iceland81KeyPD4SLiteonGreyKNormalKB	SN20Q40717	
2	Slovenian81KeyPD4SLiteonGreyKNormalKB	SN20Q40759	
2	Swiss81KeyPD4SLiteonGreyKNormalKB	SN20Q40775	
2	USInter80KeyPD4SLiteonGreyKNormalKB	SN20Q40731	
2	Czh-Slk81KeyPD4SLiteonGreyKNormalKB	SN20Q40777	
2	Bulgarian81KeyPD4SLiteonGreyKNormalKB	SN20Q40801	

No.	FRU	FRU no.	CRU ID.
2	India80KeyPD4SLiteonGreyKNormalKB	SN20Q40689	N
2	French-Arabic81KeyPD4SLiteonGreyKNormalKB	SN20Q40752	
2	Ukrainia80keyPD4SLiteonGreyKNormalKB	SN20Q40718	
2	US80KeyPD4SJMEGreyKNormalKB	SN20Q40821	
2	UK81KeyPD4SJMEGreyKNormalKB	SN20Q40629	
2	Italian81KeyPD4SJMEGreyKNormalKB	SN20Q40604	
2	Spanish81KeyPD4SJMEGreyKNormalKB	SN20Q40620	
2	Turkish81KeyPD4SJMEGreyKNormalKB	SN20Q40613	
2	Thailand80KeyPD4SJMEGreyKNormalKB	SN20Q40590	
2	Portugue81KeyPD4SJMEGreyKNormalKB	SN20Q40705	
2	LatinSpa81KeyPD4SJMEGreyKNormalKB	SN20Q40727	
2	CanadFrEn81KeyPD4SJMEGreyKNormalKB	SN20Q40738	
2	Korean80KeyPD4SJMEGreyKNormalKB	SN20Q40657	
2	TradChine80KeyPD4SJMEGreyKNormalKB	SN20Q40757	
2	Russian80KeyPD4SJMEGreyKNormalKB	SN20Q40608	
2	French81KeyPD4SJMEGreyKNormalKB	SN20Q40809	
2	German81KeyPD4SJMEGreyKNormalKB	SN20Q40656	
2	Arabic80KeyPD4SJMEGreyKNormalKB	SN20Q40741	
2	Brazilian81KeyPD4SJMEGreyKNormalKB	SN20Q40743	
2	Dutch81KeyPD4SJMEGreyKNormalKB	SN20Q40799	
2	Greek80KeyPD4SJMEGreyKNormalKB	SN20Q40817	
2	Hebrew80KeyPD4SJMEGreyKNormalKB	SN20Q40838	
2	Hungarian81KeyPD4SJMEGreyKNormalKB	SN20Q40825	
2	Nordic81KeyPD4SJMEGreyKNormalKB	SN20Q40672	
2	Belgian81KeyPD4SJMEGreyKNormalKB	SN20Q40831	
2	Iceland81KeyPD4SJMEGreyKNormalKB	SN20Q40701	
2	Slovenian81KeyPD4SJMEGreyKNormalKB	SN20Q40592	
2	Swiss81KeyPD4SJMEGreyKNormalKB	SN20Q40740	
2	USInter80KeyPD4SJMEGreyKNormalKB	SN20Q40708	
2	Czh-Slk81KeyPD4SJMEGreyKNormalKB	SN20Q40791	
2	Bulgarian81KeyPD4SJMEGreyKNormalKB	SN20Q40658	
2	India80KeyPD4SJMEGreyKNormalKB	SN20Q40813	
2	French-Arabic81KeyPD4SJMEGreyKNormalKB	SN20Q40847	
2	Ukrainia80keyPD4SJMEGreyKNormalKB	SN20Q40652	
2	US80KeyPD4SDarfonGreyKNormalKB	SN20Q40647	
2	UK81KeyPD4SDarfonGreyKNormalKB	SN20Q40732	
2	Italian81KeyPD4SDarfonGreyKNormalKB	SN20Q40660	
2	Spanish81KeyPD4SDarfonGreyKNormalKB	SN20Q40770	
2	Turkish81KeyPD4SDarfonGreyKNormalKB	SN20Q40789	
2	Thailand80KeyPD4SDarfonGreyKNormalKB	SN20Q40753	
2	Portugue81KeyPD4SDarfonGreyKNormalKB	SN20Q40807	
2	LatinSpa81KeyPD4SDarfonGreyKNormalKB	SN20Q40749	
2	CanadFrEn81KeyPD4SDarfonGreyKNormalKB	SN20Q40826	
2	Korean80KeyPD4SDarfonGreyKNormalKB	SN20Q40816	
2	TradChine80KeyPD4SDarfonGreyKNormalKB	SN20Q40709	
2	Russian80KeyPD4SDarfonGreyKNormalKB	SN20Q40848	
2	French81KeyPD4SDarfonGreyKNormalKB	SN20Q40737	
2	German81KeyPD4SDarfonGreyKNormalKB	SN20Q40686	

No.	FRU	FRU no.	CRU ID.
2	Arabic80KeyPD4SDarfonGreyKNormalKB	SN20Q40682	N
2	Brazilian81KeyPD4SDarfonGreyKNormalKB	SN20Q40783	
2	Dutch81KeyPD4SDarfonGreyKNormalKB	SN20Q40769	
2	Greek80KeyPD4SDarfonGreyKNormalKB	SN20Q40754	
2	Hebrew80KeyPD4SDarfonGreyKNormalKB	SN20Q40760	
2	Hungarian81KeyPD4SDarfonGreyKNormalKB	SN20Q40679	
2	Nordic81KeyPD4SDarfonGreyKNormalKB	SN20Q40729	
2	Belgian81KeyPD4SDarfonGreyKNormalKB	SN20Q40622	
2	Iceland81KeyPD4SDarfonGreyKNormalKB	SN20Q40742	
2	Slovenian81KeyPD4SDarfonGreyKNormalKB	SN20Q40630	
2	Swiss81KeyPD4SDarfonGreyKNormalKB	SN20Q40824	
2	USInter80KeyPD4SDarfonGreyKNormalKB	SN20Q40787	
2	Czh-Slk81KeyPD4SDarfonGreyKNormalKB	SN20Q40713	
2	Bulgarian81KeyPD4SDarfonGreyKNormalKB	SN20Q40683	
2	India80KeyPD4SDarfonGreyKNormalKB	SN20Q40594	
2	French-Arabic81KeyPD4SDarfonGreyKNormalKB	SN20Q40649	
2	Ukrainia80keyPD4SDarfonGreyKNormalKB	SN20Q40827	
3	MB L 81EK NOK 4415U UMA BL FP	5B20R08520	
3	MB L 81EK WIN 4415U UMA BL FP	5B20R08711	
3	MB L 81EK NOK I37130U UMA BL FP	5B20R08734	
3	MB L 81EK WIN I37130U UMA BL FP	5B20R08746	
3	MB L 81EK NOK I58250U UMA BL FP	5B20R08482	
3	MB L 81EK WIN I58250U UMA BL FP	5B20R08875	
3	MB L 81EK NOK I78550U UMA BL FP	5B20R08774	
3	MB L 81EK WIN I78550U UMA BL FP	5B20R08512	
3	MB L 81EK NOK 4415U UMA BL NFP	5B20R08670	
3	MB L 81EK WIN 4415U UMA BL NFP	5B20R08618	
3	MB L 81EK NOK I37130U UMA BLNFP	5B20R08877	
3	MB L 81EK WIN I37130U UMA BLNFP	5B20R08835	
3	MB L 81EK NOK I58250U UMA BLNFP	5B20R08827	
3	MB L 81EK WIN I58250U UMA BLNFP	5B20R08537	
3	MB L 81EK NOK 4415U UMA NBL FP	5B20R08668	
3	MB L 81EK WIN 4415U UMA NBL FP	5B20R08549	
3	MB L 81EK NOK I37130U UMA NBLFP	5B20R08800	
3	MB L 81EK WIN I37130U UMA NBLFP	5B20R08761	
3	MB L 81EK NOK I58250U UMA NBLFP	5B20R08685	
3	MB L 81EK WIN I58250U UMA NBLFP	5B20R08511	
3	MB L 81EK NOK 4415U UMA NBL NFP	5B20R08589	
3	MB L 81EK WIN 4415U UMA NBL NFP	5B20R08689	
3	MB L 81EK NOKI37130U UMANBL NFP	5B20R08844	
3	MB L 81EK WINI37130U UMANBL NFP	5B20R08729	
3	MB L 81EK NOKI58250U UMANBL NFP	5B20R08675	
3	MB L 81EK WINI58250U UMANBL NFP	5B20R08708	
3	MB L 81EK NOK I37130U 2G BL FP	5B20R08564	
3	MB L 81EK WIN I37130U 2G BL FP	5B20R08813	
3	MB L 81EK NOK I58250U 2G BL FP	5B20R08488	
3	MB L 81EK WIN I58250U 2G BL FP	5B20R08799	
3	MB L 81EK NOK I78550U 2G BL FP	5B20R08655	

No.	FRU	FRU no.	CRU ID.
3	MB L 81EK WIN I78550U 2G BL FP	5B20R08777	N
3	MB L 81EK NOK I37130U 2G BL NFP	5B20R08654	
3	MB L 81EK WIN I37130U 2G BL NFP	5B20R08553	
3	MB L 81EK NOK I58250U 2G BL NFP	5B20R08903	
3	MB L 81EK WIN I58250U 2G BL NFP	5B20R08732	
3	MB L 81EK NOK I37130U 2G NBL FP	5B20R08597	
3	MB L 81EK WIN I37130U 2G NBL FP	5B20R08767	
3	MB L 81EK NOK I58250U 2G NBL FP	5B20R08783	
3	MB L 81EK WIN I58250U 2G NBL FP	5B20R08647	
3	MB L 81EK NOK I37130U 2GNBL NFP	5B20R08516	
3	MB L 81EK WIN I37130U 2GNBL NFP	5B20R08778	
3	MB L 81EK NOK I58250U 2GNBL NFP	5B20R08644	
3	MB L 81EK WIN I58250U 2GNBL NFP	5B20R08595	
3	MB L 81EK NOK I37020U UMA BL FP	5B20R19600	
3	MB L 81EK WIN I37020U UMA BL FP	5B20R19605	
3	MB L 81EK NOK I37020U UMA BLNFP	5B20R19607	
3	MB L 81EK WIN I37020U UMA BLNFP	5B20R19608	
3	MB L 81EK NOK I37020U UMA NBLFP	5B20R19586	
3	MB L 81EK WIN I37020U UMA NBLFP	5B20R19606	
3	MB L 81EK NOK I37020U UMANBL NFP	5B20R19594	
3	MB L 81EK WIN I37020U UMANBL NFP	5B20R19577	
3	MB L 81EK NOK I37020U 2G BL FP	5B20R19593	
3	MB L 81EK WIN I37020U 2G BL FP	5B20R19587	
3	MB L 81EK NOK I37020U 2G BL NFP	5B20R19585	
3	MB L 81EK WIN I37020U 2G BL NFP	5B20R19573	
3	MB L 81EK NOK I37020U 2G NBL FP	5B20R19583	
3	MB L 81EK WIN I37020U 2G NBL FP	5B20R19592	
3	MB L 81EK NOK I37020U 2GNBL NFP	5B20R19579	
3	MB L 81EK WIN I37020U 2GNBL NFP	5B20R19588	
3	MB L 81EK NOK I38130U UMA BL FP	5B20R19578	
3	MB L 81EK WIN I38130U UMA BL FP	5B20R19582	
3	MB L 81EK NOK I38130U UMA BLNFP	5B20R19609	
3	MB L 81EK WIN I38130U UMA BLNFP	5B20R19591	
3	MB L 81EK NOK I38130U UMA NBLFP	5B20R19601	
3	MB L 81EK WIN I38130U UMA NBLFP	5B20R19584	
3	MB L 81EK NOK I38130U UMANBL NFP	5B20R19580	
3	MB L 81EK WIN I38130U UMANBL NFP	5B20R19604	
3	MB L 81EK NOK I38130U 2G BL FP	5B20R19589	
3	MB L 81EK WIN I38130U 2G BL FP	5B20R19575	
3	MB L 81EK NOK I38130U 2G BL NFP	5B20R19581	
3	MB L 81EK WIN I38130U 2G BL NFP	5B20R19576	
3	MB L 81EK NOK I38130U 2G NBL FP	5B20R19590	
3	MB L 81EK WIN I38130U 2G NBL FP	5B20R19597	
3	MB L 81EK NOK I38130U 2GNBL NFP	5B20R19610	
3	MB L 81EK WIN I38130U 2GNBL NFP	5B20R19603	
4	SS MZVLW128HEGR 128G PCIE SSD	5SD0L73445	
4	LIT CA1 128GB M.2 2280 PCIe SSD	5SD0N04881	
4	SS MZVLW256HEHP 256G PCIE SSD	5SD0L73444	

No.	FRU	FRU no.	CRU ID.
4	TSB XG5 256G M.2 2280 PCIe SSD (CS in Jul 2017)	SSD0P31684	N
4	Lenovo AM6671 256G M.2 2280 PCIe	5SD0N26459	
4	SAM PM981 512GB M.2 2280 PCIe (CS in Sep)	SSD0P20906	
4	TSB XG5 512G M.2 2280 PCIe SSD(CS in Jul 2017)	SSD0P31682	
4	Lenovo AM6671 512G M.2 2280 PCIe	5SD0N26460	
5	Intel 8265 2x2AC+BT PCIE M.2 WLAN NV	SW10K97453	
5	Foxconn RTL8822BE M2 WLAN	SW10K97464	
5	RTL8821CE 1x1AC+BT4.2 Combo M.2 BS	SW10K97462	
5	Ltn NFA435A 1x1AC+BT4.0 PCIE M.2 WLAN	SW10K97461	
5	Intel 3165 1x1AC+BT PCIE M.2 WLAN	SW10H24486	
6	4GB DDR4 26S M471A5244CB0-CTD	SM30N76487	
6	4GB D4 26S HMA851S6CJR6N-VKN0	SM30K25310	
6	4GB D4 26S MTA4ATF51264HZ-2G6E1	SM30K25318	
6	4GB D4 26S RMSA3270ME86H9F-2666	SM30K25316	
6	8GB DDR4 26S M471A1K43CB1-CTD	SM30N76488	
6	8GB D4 26S HMA81GS6CJR8N-VKN0	SM30K25311	
6	8GB D4 26S MTA8ATF1G64HZ-2G6E1	SM30N76493	
6	8GB D4 26S RMSA3260ME78HAF-2666	SM30N76498	
6	16GB DDR4 26S M471A2K43CB1-CTD	SM30N76489	
6	16GB D4 26S HMA82GS6CJR8N-VKN0	SM30K25312	
6	16GB D4 26S MTA16ATF2G64HZ-2G6E1	SM30N76494	
6	16GB D4 26S RMSA3300ME78HBF-2666	SM30N76499	
7	I/O Board L 81EK W/FFC	5C50R08719	
8	Heatsink L 81EK W/FAN UMA U	5H40R08709	
8	Heatsink L 81EK W/FAN DIS U	5H40R08909	
8	Heatsink L 81EK W/FAN UMA R	5H40R19595	
8	Heatsink L 81EK W/FAN DIS R	5H40R19574	
9	SP/A L17M4PB0 7.68V45Wh4cell	5B10Q16066	
9	CP/C L17C4PB0 7.68V45Wh4cell	5B10Q16067	
10	Yoga530-14 Veco 1224 Speaker	5SB0Q58700	
10	Yoga530-14 YG 1224 Speaker	5SB0Q58701	
11	Lower Case L 81EK IG	5CB0R08530	
11	Lower Case L 81EK PTN	5CB0R08610	
11	Lower Case L 81EK LB	5CB0R08582	

LCD FRUs

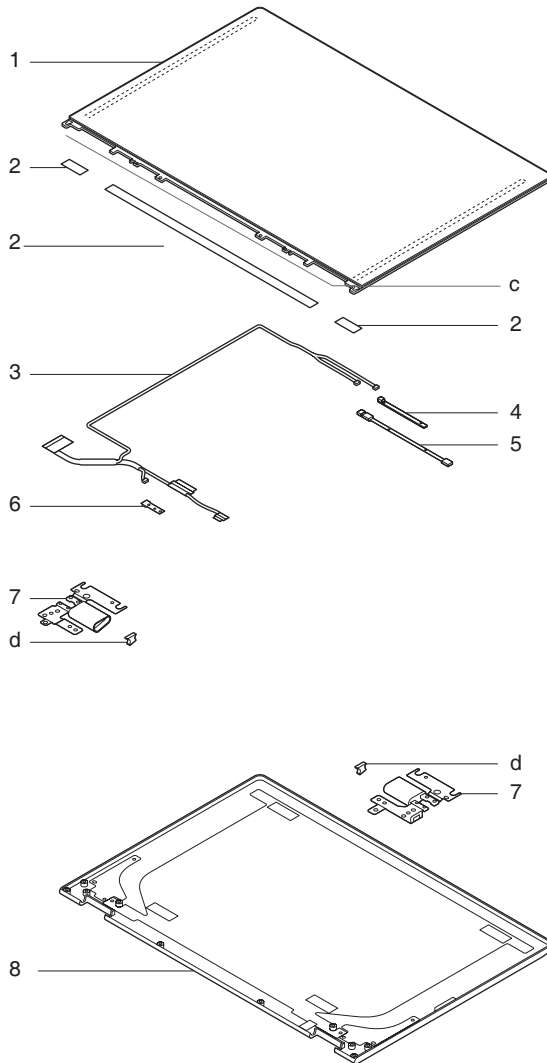

Table 5. Parts list—LCD FRUs

No.	FRU	FRU no.	CRU ID.
1	LCD Module L 81EK HD	5D10R03188	N
1	LCD Module L 81EK FHD	5D10R03189	
1	IN N140BGA-EA4 C2 HDT AG S NB	5D10M42863	
1	BO NT140WHM-N43 V8.0 HDT AG S NB	5D10M42866	
1	AU B140HAN04.0 1A FHDI AG S NB	5D10M42862	
1	IN N140HCA-EAC C2 FHDI AG S NB	5D10M42870	
1	IV M140NWF5 R2 1.1 FHDI AG S NB	5D10Q11724	
1	SLC 140037AKM OGM YG530TSP	ST50Q57063	
1	SLC 140037BKM OGM YG530TSP	ST50Q57055	
1	MTO B132216W1 GF2 YG530TSP	ST50Q57059	
1	MTO B132216W2 GF2 YG530TSP	ST50Q57057	
1	SLC INX140HD 140SC037AKF OGM	ST50Q57058	
1	MTO BOE140HD B152216W1 GF2	ST50Q57062	
1	BOE BOE140HD NT140WHM-A11 OGM	ST50Q57056	
1	SLC AUO140FHD 140SC037BKF OGM	ST50Q57054	
1	SLC IVO140FHD 140SC037CKF OGM	ST50Q57061	
1	MTO INX140FHD B152216W2 GF2	ST50Q57060	
2	Hinge Cover L 81EK	5CB0R08476	
3	EDP Cable L 81EK W/TP	5C10R08621	
4	Comn Camera Slim HD w/o MIC Bsn	SC20F27084	
4	Comn Camera Slim HD w/o MIC Chy	SC20F27083	
4	Comn Camera Slim HD w/o MIC Azw	SC20F27085	
4	Comn Camera Slim HD w/o MIC AVC	SC20F27086	
5	MIC Board L 81EK W/TP	5C50R19596	
6	Sensor Board L 81EK W/TP	5C50R19598	
7	Hinge L 81EK R+L IG	5H50R08798	
7	Hinge L 81EK R+L PTN	5H50R08495	
7	Hinge L 81EK R+L LB	5H50R08639	
7	奇宏Yoga530-14_hinge_L_AVC_Grey	SH50Q58654	
7	奇宏Yoga530-14_hinge_R_AVC_Grey	SH50Q58656	
7	玮硕Yoga530-14_hinge_L_VOSO_Grey	SH50Q58658	
7	玮硕Yoga530-14_hinge_R_VOSO_Grey	SH50Q58659	
7	奇宏Yoga530-14_hinge_L_AVC_Black	SH50Q58652	
7	奇宏Yoga530-14_hinge_R_AVC_Black	SH50Q58662	
7	玮硕Yoga530-14_hinge_L_VOSO_Black	SH50Q58660	
7	玮硕Yoga530-14_hinge_R_VOSO_Black	SH50Q58655	
7	奇宏Yoga530-14_hinge_L_AVC_Blue	SH50Q58653	
7	奇宏Yoga530-14_hinge_R_AVC_Blue	SH50Q58657	
7	玮硕Yoga530-14_hinge_L_VOSO_Blue	SH50Q58651	
7	玮硕Yoga530-14_hinge_R_VOSO_Blue	SH50Q58661	
8	LCD Cover L 81EK IG W/TP	5CB0R08787	
8	LCD Cover L 81EK PTN W/TP	5CB0R08505	
8	LCD Cover L 81EK LB W/TP	5CB0R08525	

Miscellaneous parts

Table 6. Parts list—Miscellaneous parts

FRU	FRU no.	CRU ID.
System miscellaneous parts:		
• (a) SSD Shielding L 81EK	5S60R08779	N
• (b) Dimm Shielding L 81EK	5S60R08632	
• (c) Removable Tape L 81EK	5T10R08868	
• (d) Rubber Hinge L 81EK	5R60R08894	
Note: Italicized letters in parentheses are references to the exploded view in "Overall" on page 62.		

AC power adapters

Table 7. Parts list—AC power adapters

FRU	P/N	CRU ID.
Delta ADLX65CDGC2A 20V3.25A COO	SA10M42764	*
Delta ADLX65CDGG2A 20V3.25A COO	SA10M42758	
Delta ADLX65CDGU2A 20V3.25A COO	SA10M42765	
Delta ADLX65CDGK2A 20V3.25A COO	SA10M42745	
Delta ADLX65CDGI2A 20V3.25A COO	SA10M42796	
Delta ADLX65CDGR2A 20V3.25A COO	SA10M42775	
Delta ADLX65CDGA2A 20V3.25A COO	SA10M42718	
Delta ADLX65CDGE2A 20V3.25A COO	SA10M42794	
Delta ADLX65CDGB2A 20V3.25A COO	SA10M42769	
Liteon ADLX65CLGC2A 20V3.25A COO	SA10M42791	
Liteon ADLX65CLGG2A 20V3.25A COO	SA10M42714	
Liteon ADLX65CLGU2A 20V3.25A COO	SA10M42725	
Liteon ADLX65CLGK2A 20V3.25A COO	SA10M42531	
Liteon ADLX65CLGI2A 20V3.25A COO	SA10M42753	
Liteon ADLX65CLGR2A 20V3.25A COO	SA10M42738	
Liteon ADLX65CLGA2A 20V3.25A COO	SA10M42793	
Liteon ADLX65CLGE2A 20V3.25A COO	SA10M42740	
Liteon ADLX65CLGB2A 20V3.25A COO	SA10M42817	
Chicony ADLX65CCGC2A 20V3.25A COO	SA10M42805	
Chicony ADLX65CCGG2A 20V3.25A COO	SA10M42815	
Chicony ADLX65CCGU2A 20V3.25A COO	SA10M42762	
Chicony ADLX65CCGK2A 20V3.25A COO	SA10M42735	
Chicony ADLX65CCGI2A 20V3.25A COO	SA10M42751	
Chicony ADLX65CCGR2A 20V3.25A COO	SA10M42704	
Chicony ADLX65CCGA2A 20V3.25A COO	SA10M42766	
Chicony ADLX65CCGE2A 20V3.25A COO	SA10M42760	
Chicony ADLX65CCGB2A 20V3.25A COO	SA10M42707	
Delta ADLX65NDC3A 20V3.25A RCOO	SA10M42715	
Liteon ADLX65NLC3A 20V3.25A R	5A10J40449	
Chicony ADLX65NCC3A 20V3.25A RCOO	SA10M42747	
LINETEK PC323+RVV300/300+LS15 1 m	145000600	

Table 7. Parts list—AC power adapters (continued)

FRU	P/N	CRU ID.
LINETEK LS15+H03VV-F+LP39 1 m	145000599	*
LINETEK LS15+H03VV-F+LP-37 1 m	145000597	
LINETEK LS15 H03VV-F LP26A 1 m	145000596	
LINETEK LS15+H03VV-F+LP-41 1 m	145000595	
LINETEK LP-30B + SPT-2 + LS15 1 m	145000594	
LINETEK LP-61L+ H03VV-F+ LS15 1 m	145000593	
LINETEK PE-361+ H05VV-F+ LS15 1 m	145000592	
LINETEK LS15+H03VV-F+PE-336 1 m	145000591	
LINETEK LS15+H05VV-F+LP-E04A 1 m	145000590	
LINETEK LS15+H03VV-F+LP-23A 1 m	145000589	
LINETEK LS15+VCTF+LP-53 1 m	145000588	
LINETEK LS15+VCTF+LP-54 1 m	145000587	
LINETEK LS15+H03VV-F+PE-364 1 m	145000586	
LINETEK LP-34+H03VV-F + LS15 1 m	145000585	
Longwell LSG-31+RVV300/300+LS-18 1 m	145000568	
Longwell LP-24+H03VV-F+LS-18 1 m	145000567	
Longwell LP-37+H03VV-F+LS-18 1 m	145000565	
Longwell LP-46+H03VV-F+LS-18 1 m	145000564	
Longwell LP-41+H03VV-F+LS-18 1 m	145000563	
Longwell LP-30B+SPT-2 18AWG+LS-18 1 m	145000562	
Longwell LP-61L+H03VV-F+LS-18 1 m	145000561	
Longwell LP-67+BIS+LS-18 1 m	145000560	
Longwell LP-22+H03VV-F+LS-18 1 m	145000559	
Longwell LP-486+KTLH03VV-F+LS-5 1 m	145000558	
Longwell LP-23A+LFC-3R+LS-18 1 m	145000557	
Longwell LP-71+VCTF+LS-33 1 m	145000556	
Longwell LP-54+VCTF+LS-18 1 m	145000555	
Longwell LP-39+H03VV-F+LS-18 1 m	145000554	
Longwell LP-34A+H03VV-F+LS-18 1 m	145000553	
VOLEX GB10S3+RVV 300/500+VAC5S 1 m	145000538	
Volex US15S3+SPT-2 +VAC5S 1 m	145000537	
VOLEX MP5004+H03VV-F+VAC5S 1 m	145000605	
VOLEX MP232+H03VV-F+VAC5S 1 m	145000524	
VOLEX IT10S3+H03VV-F+VAC5S 1 m	145000535	
VOLEX M2511+KETI IEC+VAC5S 1 m	145000533	
VOLEX AU10S3+H03VV-F+VAC5S 1 m	145000532	
VOLEX TW15CS3+VCTF+VAC5S 1 m	145000531	
VOLEX VAC5S+VCTF+M755 1 m	145000530	
VOLEX VA2073+H03VV-F+VAC5S 1 m	145000528	
VOLEX CH10S3+H03VV-F+VAC5S 1 m	145000527	
VOLEX SI16S3+H03VV-F+VAC5S 1 m	145000526	
VOLEX M2511+H03VV-F+VAC5S 1 m	145000525	
lux 0036+RVV 300/300 0.75/3C+0002 1 m	145500003	
lux 0040+H03VV-F 0.75/3C+0011 1 m	145500015	
lux 0027+H03VV-F 0.75/3C+0011 1 m	145500013	
lux 0034+H03VV-F 0.75/3C+0011 1 m	145500011	
lux 0041+H03VV-F 0.75/3C+0011 1 m	145500012	

Table 7. Parts list—AC power adapters (continued)

FRU	P/N	CRU ID.
lux 0014+SPT-2 60°C 18/3C+0016 1 m	145500002	*
lux 0014+H03VV-F 0.75/3C+0011 1 m	5L60J33143	
lux 0031+H03VV-F 0.75/3C+0011 1 m	145500000	
lux 0046+IS694 0.75/3C+0011 1 m	145500004	
lux 0029+H03VV-F 0.75/3C+0011 1 m	145500009	
lux 0033+H03VV-F 0.75/3C+0011 1 m	145500008	
lux 0038+H03VV-F 0.75/3C+0011 1 m	145500006	
lux 0019+VCTF 0.75/3C+0021 1 m	145500007	
lux 0018(E)+VCTF 0.75/3C+0021 1 m	145500005	
lux 0044+H03VV-F 0.75/3C+0011 1 m	145500010	
lux 0033+H03VV-F 0.75/3C+0011 1 m	145500001	

Screws

Table 8. Parts list—screws

FRU	P/N	CRU ID.
Screw L 81EK 2L 7D 0.5T NL + CR3+	5S10R08551	N
Screw L 81EK 3.0L 3.5D 0.5T BNI NL	5S10R08878	
Screw L 81EK 6.5L 3.4D 0.4T NI NL	5S10R08744	
Screw L 81EK 3.5L 4.5D 0.5T ZK +	5S10R08720	
Screw L 81EK 4L 4.5D 0.8T BNI NL	5S10R19602	
Screw L 81EK 6.5L 3.4D 0.4T BNL NL	5S10R19599	

Notices

Lenovo may not offer the products, services, or features discussed in this document in all countries. Consult your local Lenovo representative for information on the products and services currently available in your area. Any reference to a Lenovo product, program, or service is not intended to state or imply that only that Lenovo product, program, or service may be used. Any functionally equivalent product, program, or service that does not infringe any Lenovo intellectual property right may be used instead. However, it is the user's responsibility to evaluate and verify the operation of any other product, program, or service.

Lenovo may have patents or pending patent applications covering subject matter described in this document. The furnishing of this document does not give you any license to these patents.

LENOVO GROUP LTD. PROVIDES THIS PUBLICATION "AS IS" WITHOUT WARRANTY OF ANY KIND, EITHER EXPRESS OR IMPLIED, INCLUDING, BUT NOT LIMITED TO, THE IMPLIED WARRANTIES OF NON-INFRINGEMENT, MERCHANTABILITY OR FITNESS FOR A PARTICULAR PURPOSE. Some jurisdictions do not allow disclaimer of express or implied warranties in certain transactions, therefore, this statement may not apply to you.

This information could include technical inaccuracies or typographical errors. Changes are periodically made to the information herein; these changes will be incorporated in new editions of the publication. Lenovo may make improvements and/or changes in the product(s) and/or the program(s) described in this publication at any time without notice.

The products described in this document are not intended for use in implantation or other life support applications where malfunction may result in injury or death to persons. The information contained in this document does not affect or change Lenovo product specifications or warranties. Nothing in this document shall operate as an express or implied license or indemnity under the intellectual property rights of Lenovo or third parties. All information contained in this document was obtained in specific environments and is presented as an illustration. The result obtained in other operating environments may vary.

Lenovo may use or distribute any of the information you supply in any way it believes appropriate without incurring any obligation to you.

Any references in this publication to non-Lenovo Web sites are provided for convenience only and do not in any manner serve as an endorsement of those Web sites. The materials at those Web sites are not part of the materials for this Lenovo product, and use of those Web sites is at your own risk.

Any performance data contained herein was determined in a controlled environment. Therefore, the result obtained in other operating environments may vary significantly. Some measurements may have been made on development-level systems and there is no guarantee that these measurements will be the same on generally available systems. Furthermore, some measurements may have been estimated through extrapolation. Actual results may vary. Users of this document should verify the applicable data for their specific environment.

Trademarks

Lenovo is a trademark or registered trademark of Lenovo in the United States, other countries, or both.

Microsoft and Windows are trademarks of Microsoft Corporation in the United States, other countries, or both.

Other company, products, or service names may be trademarks or service marks of others.