

# Dell Vostro 15-7580

## Owners Manual



## Notes, cautions, and warnings

 | **NOTE:** A NOTE indicates important information that helps you make better use of your product.

 | **CAUTION:** A CAUTION indicates either potential damage to hardware or loss of data and tells you how to avoid the problem.

 | **WARNING:** A WARNING indicates a potential for property damage, personal injury, or death.

© 2018 Dell Inc. or its subsidiaries. All rights reserved. Dell, EMC, and other trademarks are trademarks of Dell Inc. or its subsidiaries. Other trademarks may be trademarks of their respective owners.

# Contents

|   |           |
|---|-----------|
| <b>1 Working on your computer</b> .....           | <b>7</b>  |
| Safety precautions.....                           | 7         |
| Standby power.....                                | 7         |
| Bonding .....                                     | 7         |
| Electrostatic discharge—ESD protection.....       | 7         |
| ESD field service kit .....                       | 8         |
| Transporting sensitive components.....            | 9         |
| Before working inside your computer.....          | 9         |
| After working inside your computer.....           | 9         |
| <b>2 Removing and installing components</b> ..... | <b>11</b> |
| Base cover.....                                   | 11        |
| Removing the base cover.....                      | 11        |
| Installing the base cover.....                    | 12        |
| Battery.....                                      | 12        |
| Removing the battery.....                         | 12        |
| Installing the battery.....                       | 13        |
| Coin cell battery.....                            | 14        |
| Removing the coin cell battery.....               | 14        |
| Installing the coin cell battery.....             | 14        |
| Memory modules.....                               | 15        |
| Removing the memory module.....                   | 15        |
| Installing the memory module.....                 | 15        |
| Hard drive.....                                   | 16        |
| Removing the hard drive.....                      | 16        |
| Installing the hard drive.....                    | 17        |
| Solid State Drive — optional .....                | 17        |
| Removing the M.2 Solid State Drive — SSD.....     | 17        |
| Installing the M.2 Solid State Drive — SSD.....   | 18        |
| WLAN card.....                                    | 18        |
| Removing the WLAN card.....                       | 18        |
| Installing the WLAN card.....                     | 19        |
| Rear cover.....                                   | 19        |
| Removing the rear cover.....                      | 19        |
| Installing the rear cover.....                    | 21        |
| Back cover.....                                   | 22        |
| Removing the back cover.....                      | 22        |
| Installing the back cover.....                    | 28        |
| Speaker.....                                      | 28        |
| Removing the speaker.....                         | 28        |
| Installing the speaker.....                       | 30        |
| System board.....                                 | 30        |
| Removing the system board.....                    | 30        |



|   |    |
|---|----|
| Installing the system board.....                | 33 |
| Power connector port.....                       | 34 |
| Removing the power connector port.....          | 34 |
| Installing the power connector port.....        | 35 |
| Heat sink .....                                 | 35 |
| Removing the heat sink assembly.....            | 35 |
| Installing the heat sink assembly.....          | 37 |
| Touchpad.....                                   | 37 |
| Removing the touchpad.....                      | 37 |
| Installing the touchpad.....                    | 39 |
| LED board.....                                  | 39 |
| Removing the LED board.....                     | 39 |
| Installing the LED board.....                   | 40 |
| Power button board.....                         | 40 |
| Removing the power button board.....            | 40 |
| Installing the power button board.....          | 42 |
| Fingerprint reader.....                         | 43 |
| Removing the fingerprint reader.....            | 43 |
| Installing the fingerprint reader.....          | 44 |
| Keyboard.....                                   | 44 |
| Removing the keyboard.....                      | 44 |
| Installing the keyboard.....                    | 46 |
| Display assembly.....                           | 47 |
| Removing the display assembly.....              | 47 |
| Installing the display assembly.....            | 48 |
| Palm rest.....                                  | 49 |
| Removing the palm rest assembly.....            | 49 |
| Display bezel.....                              | 50 |
| Removing the display bezel.....                 | 50 |
| Installing the display bezel.....               | 52 |
| Camera.....                                     | 52 |
| Removing the camera.....                        | 52 |
| Installing the camera.....                      | 53 |
| Display hinges.....                             | 54 |
| Removing the display hinge.....                 | 54 |
| Installing the display hinge.....               | 55 |
| Display panel.....                              | 55 |
| Removing the display panel — Non touch.....     | 55 |
| Installing the display panel.....               | 57 |
| eDP cable.....                                  | 57 |
| Removing the eDP cable.....                     | 57 |
| Installing the eDP cable.....                   | 58 |
| Display back cover assembly.....                | 59 |
| Removing the display back cover assembly.....   | 59 |
| Installing the display back cover assembly..... | 59 |

**3 Technology and components..... 61**



|   |           |
|---|-----------|
| AC Adapters.....                                    | 61        |
| How to check the status of AC Adapter in BIOS?..... | 61        |
| DDR4.....   | 61        |
| DDR4 Details.....                                   | 62        |
| Memory Errors.....                                  | 62        |
| USB features.....                                   | 63        |
| USB 3.0/USB 3.1 Gen 1 (SuperSpeed USB).....         | 63        |
| Speed.....  | 63        |
| Applications.....                                   | 64        |
| Compatibility.....                                  | 64        |
| USB Type-C.....                                     | 65        |
| Alternate Mode.....                                 | 65        |
| USB Power Delivery.....                             | 65        |
| USB Type-C and USB 3.1.....                         | 65        |
| NVIDIA GeForce GTX 1050 Graphics.....               | 65        |
| Features.....                                       | 65        |
| Power ConsumptionKey Specifications.....            | 66        |
| NVIDIA GeForce GTX 1050Ti Graphics.....             | 66        |
| Features.....                                       | 66        |
| Power ConsumptionKey Specifications.....            | 66        |
| NVIDIA GeForce GTX 1060 Graphics.....               | 67        |
| Features.....                                       | 67        |
| Power ConsumptionKey Specifications.....            | 67        |
| <b>4 System specifications.....</b>                 | <b>69</b> |
| Processor.....                                      | 69        |
| Memory .....  | 69        |
| Video.....  | 70        |
| Audio.....  | 70        |
| Connectivity options.....                           | 71        |
| Ports and Connectors.....                           | 71        |
| Display specifications.....                         | 71        |
| Keyboard.....                                       | 72        |
| Touchpad.....                                       | 72        |
| Storage.....  | 73        |
| Battery specifications.....                         | 73        |
| Adapter options.....                                | 74        |
| Webcam specifications.....                          | 74        |
| System dimensions Vostro 15-7580.....               | 75        |
| Environmental.....                                  | 75        |
| <b>5 System setup.....</b>                          | <b>77</b> |
| Boot menu.....                                      | 77        |
| Navigation keys.....                                | 77        |
| System setup options.....                           | 78        |
| General options.....                                | 78        |
| System configuration.....                           | 79        |



|  |            |
|--|------------|
| Video screen options.....  | 81         |
| Security.....  | 81         |
| Secure boot.....   | 83         |
| Intel Software Guard Extensions options.....                                     | 84         |
| Performance.....   | 84         |
| Power management.....  | 85         |
| Post behavior.....   | 86         |
| Virtualization support.....  | 87         |
| Wireless options.....  | 88         |
| Maintenance.....   | 88         |
| System logs.....   | 89         |
| SupportAssist system resolution.....   | 89         |
| Updating the BIOS in Windows .....   | 89         |
| Updating BIOS on systems with bitlocker enabled.....                             | 90         |
| Updating your system BIOS using a USB flash drive.....                           | 90         |
| Updating the Dell BIOS in Linux and Ubuntu environments.....                     | 91         |
| Flashing the BIOS from the F12 One-Time boot menu.....                           | 91         |
| System and setup password.....   | 95         |
| Assigning a system password and setup password.....                              | 95         |
| Deleting or changing an existing system setup password.....                      | 96         |
| <b>6 Software.....</b>   | <b>97</b>  |
| Operating system configurations.....   | 97         |
| Chipset drivers.....   | 97         |
| USB drivers.....   | 98         |
| Network drivers.....   | 99         |
| Audio drivers.....   | 99         |
| Storage controller drivers.....  | 99         |
| Bluetooth drivers.....   | 99         |
| Security drivers.....  | 99         |
| <b>7 Troubleshooting.....</b>  | <b>101</b> |
| Enhanced Pre-Boot System Assessment — ePSA diagnostics.....                      | 101        |
| Running the ePSA Diagnostics.....  | 101        |
| Diagnostic LED.....  | 101        |
| Battery status lights.....   | 102        |
| Dell Docking Solution.....   | 102        |
| Thunderbolt 3 Type-C port does not support certain docking systems features..... | 102        |
| Hybrid Power.....  | 103        |
| <b>8 Getting help.....</b>   | <b>104</b> |
| Contacting Dell.....   | 104        |



# Working on your computer

Topics:

- [Safety precautions](#)
- [Before working inside your computer](#)
- [After working inside your computer](#)

## Safety precautions

The safety precautions chapter details the primary steps to be taken before performing any disassembly instructions.

Observe the following safety precautions before you perform any installation or break/fix procedures involving disassembly or reassembly:

- Turn off the system and all attached peripherals.
- Disconnect the system and all attached peripherals from AC power.
- Disconnect all network cables, telephone, and telecommunications lines from the system.
- Use an ESD field service kit when working inside any notebook to avoid electrostatic discharge (ESD) damage.
- After removing any system component, carefully place the removed component on an anti-static mat.
- Wear shoes with non-conductive rubber soles to reduce the chance of getting electrocuted.

## Standby power

Dell products with standby power must be unplugged before you open the case. Systems that incorporate standby power are essentially powered while turned off. The internal power enables the system to be remotely turned on (wake on LAN) and suspended into a sleep mode and has other advanced power management features.

Unplugging, pressing and holding the power button for 15 seconds should discharge residual power in the system board, notebooks

## Bonding

Bonding is a method for connecting two or more grounding conductors to the same electrical potential. This is done through the use of a field service electrostatic discharge (ESD) kit. When connecting a bonding wire, ensure that it is connected to bare metal and never to a painted or non-metal surface. The wrist strap should be secure and in full contact with your skin, and ensure that you remove all jewelry such as watches, bracelets, or rings prior to bonding yourself and the equipment.

## Electrostatic discharge—ESD protection

ESD is a major concern when you handle electronic components, especially sensitive components such as expansion cards, processors, memory DIMMs, and system boards. Very slight charges can damage circuits in ways that may not be obvious, such as intermittent problems or a shortened product life span. As the industry pushes for lower power requirements and increased density, ESD protection is an increasing concern.

Due to the increased density of semiconductors used in recent Dell products, the sensitivity to static damage is now higher than in previous Dell products. For this reason, some previously approved methods of handling parts are no longer applicable.



Two recognized types of ESD damage are catastrophic and intermittent failures.

- **Catastrophic** – Catastrophic failures represent approximately 20 percent of ESD-related failures. The damage causes an immediate and complete loss of device functionality. An example of catastrophic failure is a memory DIMM that has received a static shock and immediately generates a "No POST/No Video" symptom with a beep code emitted for missing or nonfunctional memory.
- **Intermittent** – Intermittent failures represent approximately 80 percent of ESD-related failures. The high rate of intermittent failures means that most of the time when damage occurs, it is not immediately recognizable. The DIMM receives a static shock, but the tracing is merely weakened and does not immediately produce outward symptoms related to the damage. The weakened trace may take weeks or months to melt, and in the meantime may cause degradation of memory integrity, intermittent memory errors, etc.

The more difficult type of damage to recognize and troubleshoot is the intermittent (also called latent or "walking wounded") failure.

Perform the following steps to prevent ESD damage:

- Use a wired ESD wrist strap that is properly grounded. The use of wireless anti-static straps is no longer allowed; they do not provide adequate protection. Touching the chassis before handling parts does not ensure adequate ESD protection on parts with increased sensitivity to ESD damage.
- Handle all static-sensitive components in a static-safe area. If possible, use anti-static floor pads and workbench pads.
- When unpacking a static-sensitive component from its shipping carton, do not remove the component from the anti-static packing material until you are ready to install the component. Before unwrapping the anti-static packaging, ensure that you discharge static electricity from your body.
- Before transporting a static-sensitive component, place it in an anti-static container or packaging.

## ESD field service kit

The unmonitored Field Service kit is the most commonly used service kit. Each Field Service kit includes three main components: anti-static mat, wrist strap, and bonding wire.

## Components of an ESD field service kit

The components of an ESD field service kit are:

- **Anti-Static Mat** – The anti-static mat is dissipative and parts can be placed on it during service procedures. When using an anti-static mat, your wrist strap should be snug and the bonding wire should be connected to the mat and to any bare metal on the system being worked on. Once deployed properly, service parts can be removed from the ESD bag and placed directly on the mat. ESD-sensitive items are safe in your hand, on the ESD mat, in the system, or inside a bag.
- **Wrist Strap and Bonding Wire** – The wrist strap and bonding wire can be either directly connected between your wrist and bare metal on the hardware if the ESD mat is not required, or connected to the anti-static mat to protect hardware that is temporarily placed on the mat. The physical connection of the wrist strap and bonding wire between your skin, the ESD mat, and the hardware is known as bonding. Use only Field Service kits with a wrist strap, mat, and bonding wire. Never use wireless wrist straps. Always be aware that the internal wires of a wrist strap are prone to damage from normal wear and tear, and must be checked regularly with a wrist strap tester in order to avoid accidental ESD hardware damage. It is recommended to test the wrist strap and bonding wire at least once per week.
- **ESD Wrist Strap Tester** – The wires inside of an ESD strap are prone to damage over time. When using an unmonitored kit, it is a best practice to regularly test the strap prior to each service call, and at a minimum, test once per week. A wrist strap tester is the best method for doing this test. If you do not have your own wrist strap tester, check with your regional office to find out if they have one. To perform the test, plug the wrist-strap's bonding-wire into the tester while it is strapped to your wrist and push the button to test. A green LED is lit if the test is successful; a red LED is lit and an alarm sounds if the test fails.
- **Insulator Elements** – It is critical to keep ESD sensitive devices, such as plastic heat sink casings, away from internal parts that are insulators and often highly charged.
- **Working Environment** – Before deploying the ESD Field Service kit, assess the situation at the customer location. For example, deploying the kit for a server environment is different than for a desktop or portable environment. Servers are typically installed in a rack within a data center; desktops or portables are typically placed on office desks or cubicles. Always look for a large open flat work area that is free of clutter and large enough to deploy the ESD kit with additional space to accommodate the type of system that is being repaired. The workspace should also be free of insulators that can cause an ESD event. On the work area, insulators such as Styrofoam and other plastics should always be moved at least 12 inches or 30 centimeters away from sensitive parts before physically handling any hardware components.
- **ESD Packaging** – All ESD-sensitive devices must be shipped and received in static-safe packaging. Metal, static-shielded bags are preferred. However, you should always return the damaged part using the same ESD bag and packaging that the new part arrived in. The ESD bag should be folded over and taped shut and all the same foam packing material should be used in the original box that the new part arrived in. ESD-sensitive devices should be removed from packaging only at an ESD-protected work surface, and parts should

never be placed on top of the ESD bag because only the inside of the bag is shielded. Always place parts in your hand, on the ESD mat, in the system, or inside an anti-static bag.

- **Transporting Sensitive Components** – When transporting ESD sensitive components such as replacement parts or parts to be returned to Dell, it is critical to place these parts in anti-static bags for safe transport.

## ESD protection summary

It is recommended that all field service technicians use the traditional wired ESD grounding wrist strap and protective anti-static mat at all times when servicing Dell products. In addition, it is critical that technicians keep sensitive parts separate from all insulator parts while performing service and that they use anti-static bags for transporting sensitive components.

## Transporting sensitive components

When transporting ESD sensitive components such as replacement parts or parts to be returned to Dell, it is critical to place these parts in anti-static bags for safe transport.

## Lifting equipment

Adhere to the following guidelines when lifting heavy weight equipment:

**⚠ CAUTION: Do not lift greater than 50 pounds. Always obtain additional resources or use a mechanical lifting device.**

- 1 Get a firm balanced footing. Keep your feet apart for a stable base, and point your toes out.
- 2 Tighten stomach muscles. Abdominal muscles support your spine when you lift, offsetting the force of the load.
- 3 Lift with your legs, not your back.
- 4 Keep the load close. The closer it is to your spine, the less force it exerts on your back.
- 5 Keep your back upright, whether lifting or setting down the load. Do not add the weight of your body to the load. Avoid twisting your body and back.
- 6 Follow the same techniques in reverse to set the load down.

## Before working inside your computer

- 1 Ensure that your work surface is flat and clean to prevent the computer cover from being scratched.
- 2 Turn off your computer.
- 3 If the computer is connected to a docking device (docked), undock it.
- 4 Disconnect all network cables from the computer (if available).

**⚠ CAUTION: If your computer has an RJ45 port, disconnect the network cable by first unplugging the cable from your computer.**

- 5 Disconnect your computer and all attached devices from their electrical outlets.
- 6 Open the display.
- 7 Press and hold the power button for few seconds, to ground the system board.

**⚠ CAUTION: To guard against electrical shock unplug your computer from the electrical outlet before performing Step # 8.**

**⚠ CAUTION: To avoid electrostatic discharge, ground yourself by using a wrist grounding strap or by periodically touching an unpainted metal surface at the same time as touching a connector on the back of the computer.**

- 8 Remove any installed ExpressCards or Smart Cards from the appropriate slots.

## After working inside your computer

After you complete any replacement procedure, ensure that you connect external devices, cards, and cables before turning on your computer.



 **CAUTION:** To avoid damage to the computer, use only the battery designed for this particular Dell computer. Do not use batteries designed for other Dell computers.

- 1 Connect any external devices, such as a port replicator or media base, and replace any cards, such as an ExpressCard.
- 2 Connect any telephone or network cables to your computer.

 **CAUTION:** To connect a network cable, first plug the cable into the network device and then plug it into the computer.

- 3 Connect your computer and all attached devices to their electrical outlets.
- 4 Turn on your computer.

# Removing and installing components

## Base cover

### Removing the base cover

- 1 Follow the procedure in [Before working inside your computer](#).
- 2 To remove the base cover:
  - a Loosen the single M2.5x2+3.5 captive screw that secures the base cover to the system [1].
  - b Pry the base cover from the edge [2].

**NOTE:** You may need a plastic scribe to pry the base cover from the edge.

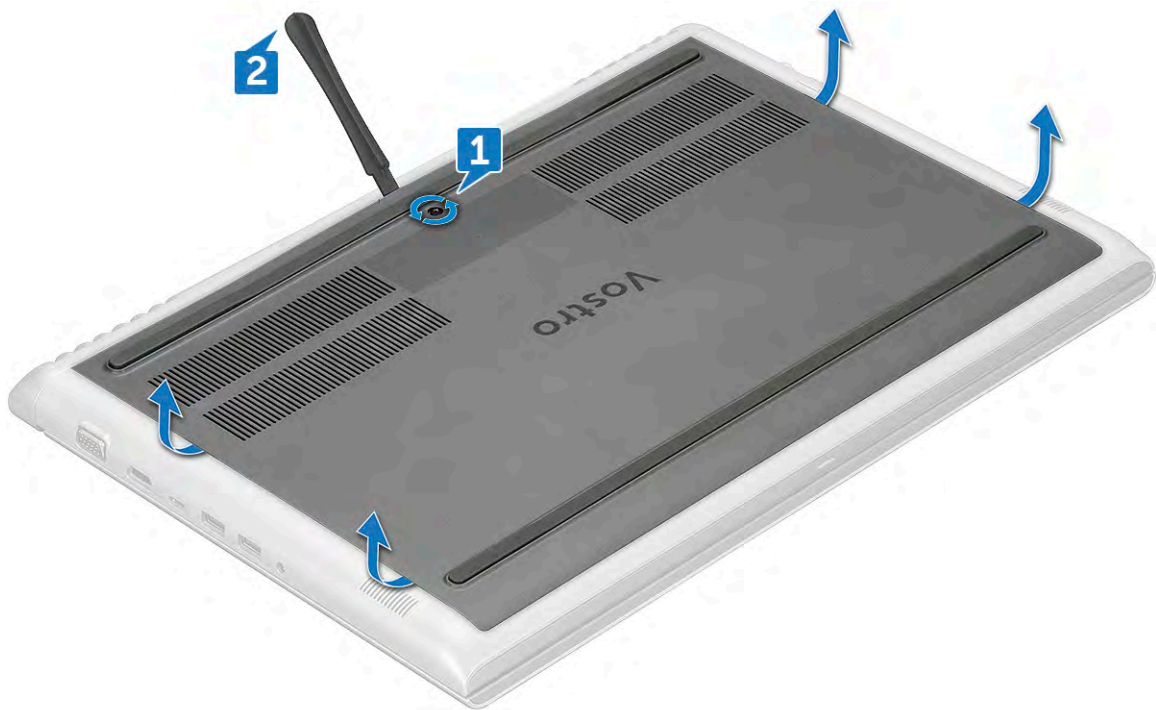

- 3 Lift the base cover away from the system.



## Installing the base cover

- 1 Align the base cover with the screw holder on the system.
- 2 Press the edges of the cover until it clicks into place.
- 3 Tighten the M2.5x2+3.5 screw to secure the base cover to the system.
- 4 Follow the procedure in [After working inside your computer](#).

## Battery

### Removing the battery

- 1 Follow the procedure in [Before working inside your computer](#).
- 2 Remove the [base cover](#).
- 3 To remove the battery:
  - a Disconnect the battery cable from the connector on the system board [1].
  - b Remove the three (M2x3) screws that secure the battery to the system [2].

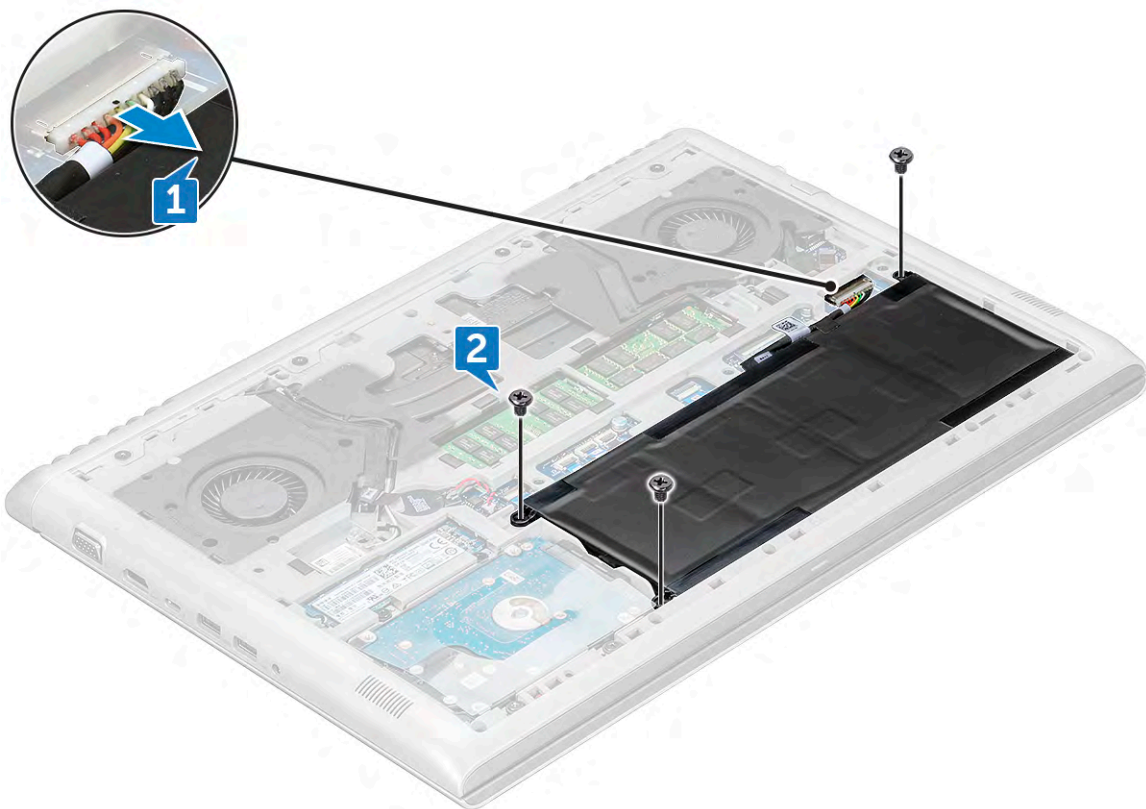

4 Lift the battery away from the system.

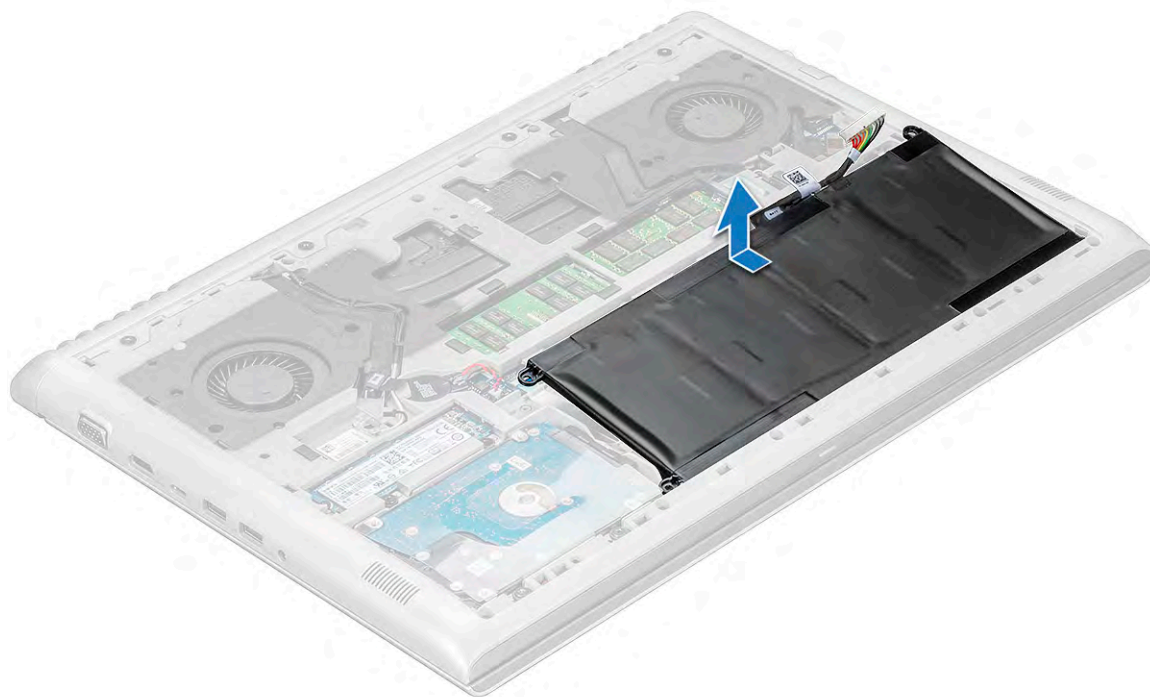

## Installing the battery

- 1 Insert the battery into the slot on the system.
- 2 Connect the battery cable to the connector on the system board.



- 3 Replace the M2x3 screws that secure the battery to the system.
- 4 Install the [base cover](#)
- 5 Follow the procedure in [After working inside your computer](#).

## Coin cell battery

### Removing the coin cell battery

- 1 Follow the procedure in [Before working inside your computer](#).
- 2 Remove the:
  - a [base cover](#)
  - b [battery](#)
- 3 To remove the coin cell battery:
  - a Disconnect the coin cell battery cable from the connector on the system board [1].
  - b Pry the coin cell battery to release from the adhesive and lift it away from the system board [2].

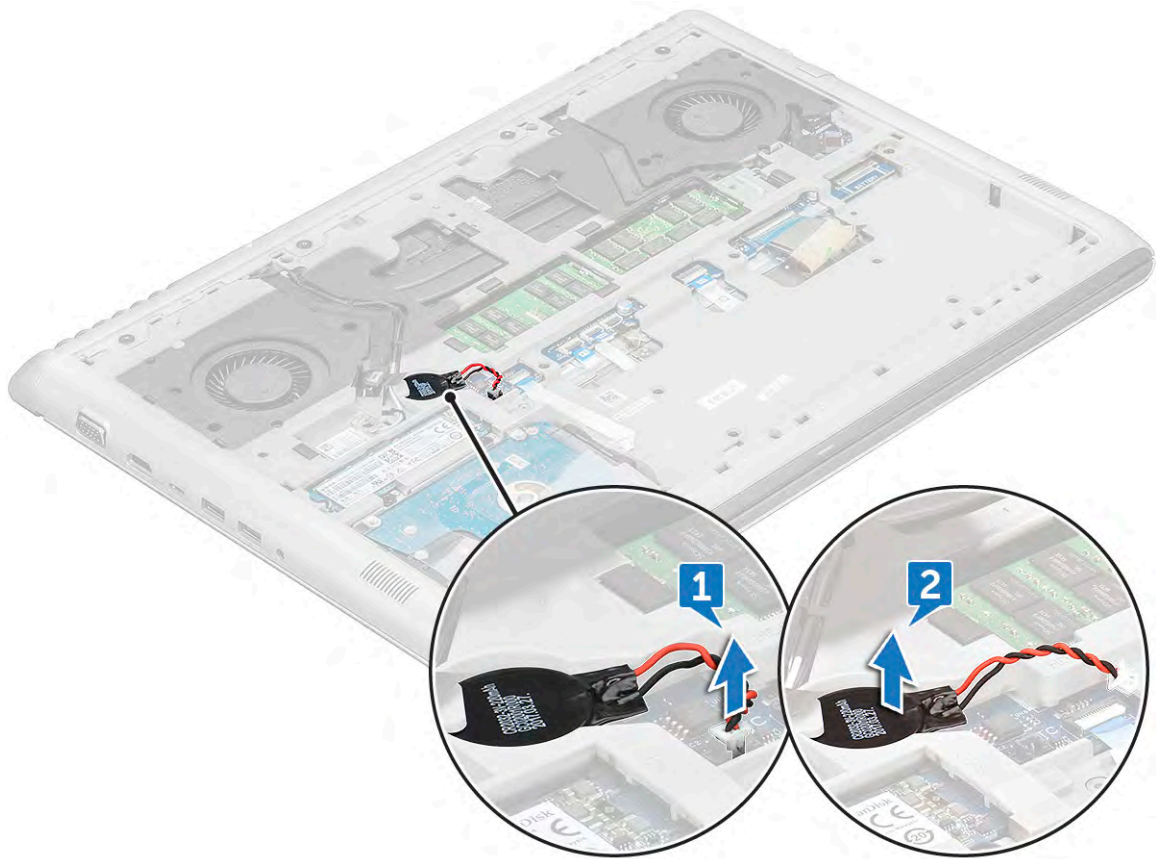

### Installing the coin cell battery

- 1 Place the coin cell battery into the slot on the system board.
- 2 Connect the coin cell battery cable to the connector on the system board.
- 3 Install the:
  - a [battery](#)
  - b [base cover](#)
- 4 Follow the procedure in [After working inside your computer](#).

# Memory modules

## Removing the memory module

- 1 Follow the procedure in [Before working inside your computer](#).
- 2 Remove the:
  - a [base cover](#)
  - b [battery](#)
- 3 To remove the memory module:
  - a Pry the retention clips securing the memory module until the memory pops-up [1].
  - b Lift the memory module away from the system [2].

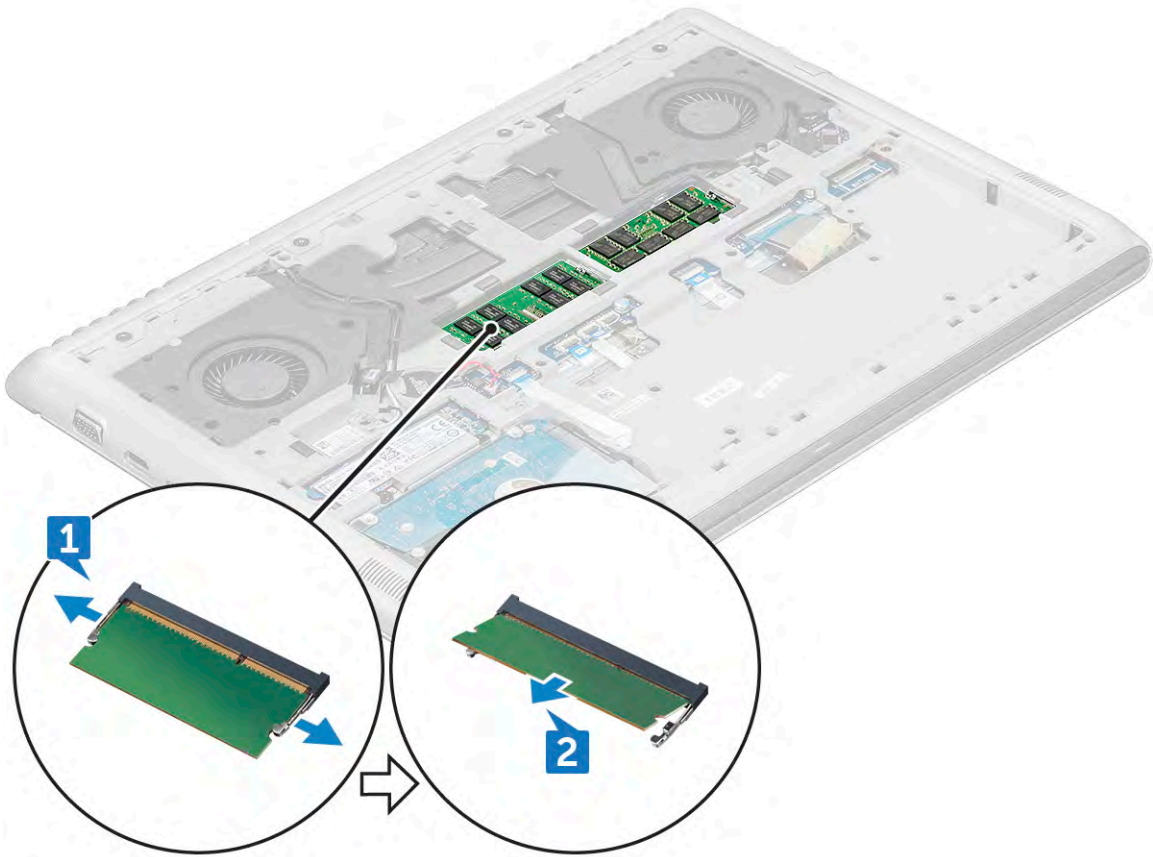

## Installing the memory module

- 1 Insert the memory module into the memory module socket until the clips secure the memory module.
- 2 Install the:
  - a [battery](#)
  - b [base cover](#)
- 3 Follow the procedure in [After working inside your computer](#).

# Hard drive

## Removing the hard drive

- 1 Follow the procedure in [Before working inside your computer](#).
- 2 Remove the:
  - a [base cover](#)
  - b [battery](#)
- 3 To disconnect the cable:
  - a Lift the latch and disconnect the hard drive cable from the system [1].
  - b Pry the hard drive cable to release from the adhesive [2].

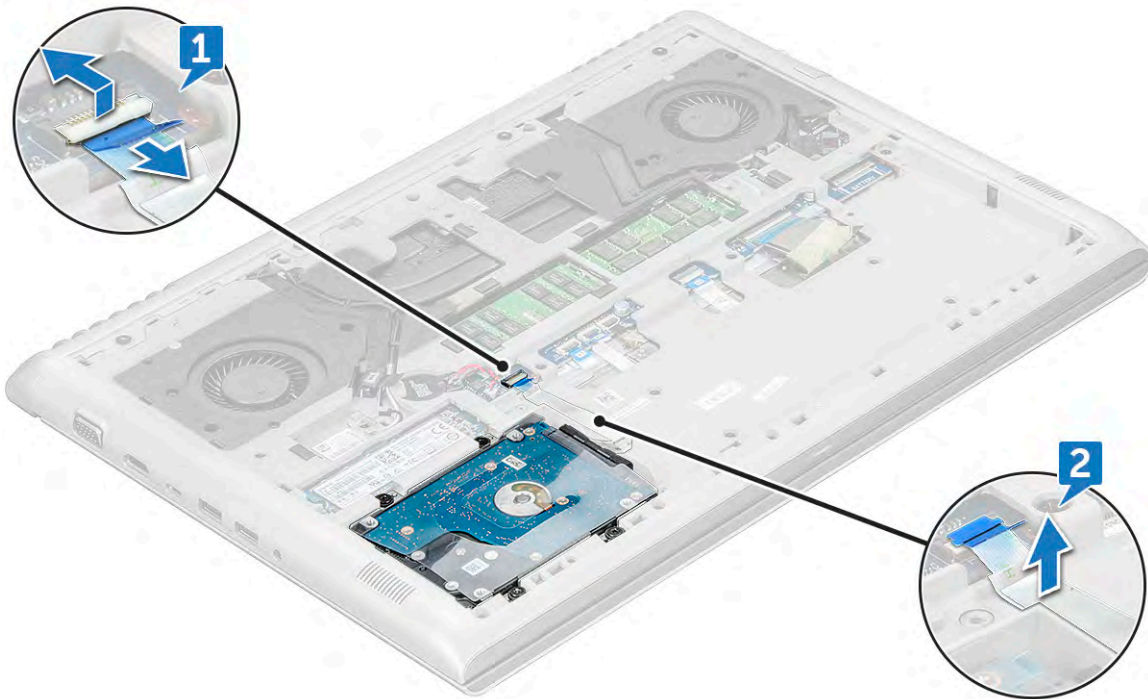

- 4 To remove the hard drive:
  - a Remove the four (M2.5x3) screws that secure the hard drive to the system [1].
  - b Lift the hard drive away from the system [2].

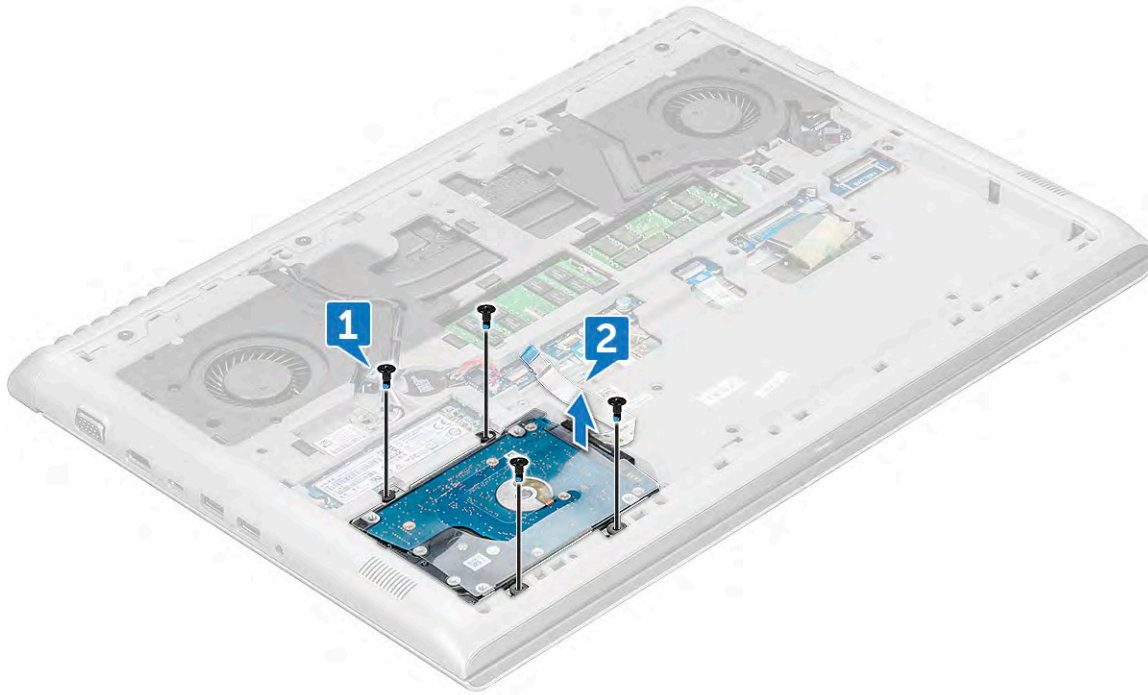

## Installing the hard drive

- 1 Insert the hard drive into the slot on the system.
- 2 Replace the M2.5x3 screws to secure the hard drive assembly to the system.
- 3 Affix the hard drive cable on the system.
- 4 Connect the hard drive cable to the connector on the system board.
- 5 Install the:
  - a battery
  - b base cover
- 6 Follow the procedure in [After working inside your computer](#).

## Solid State Drive — optional

### Removing the M.2 Solid State Drive — SSD

- 1 Follow the procedure in [Before working inside your computer](#).
- 2 Remove the:
  - a base cover
  - b battery
- 3 To remove the SSD:
  - a Remove the single (M2x3) screw that secures the SSD to the system [1].
  - b Slide and lift the SSD from the system [2].

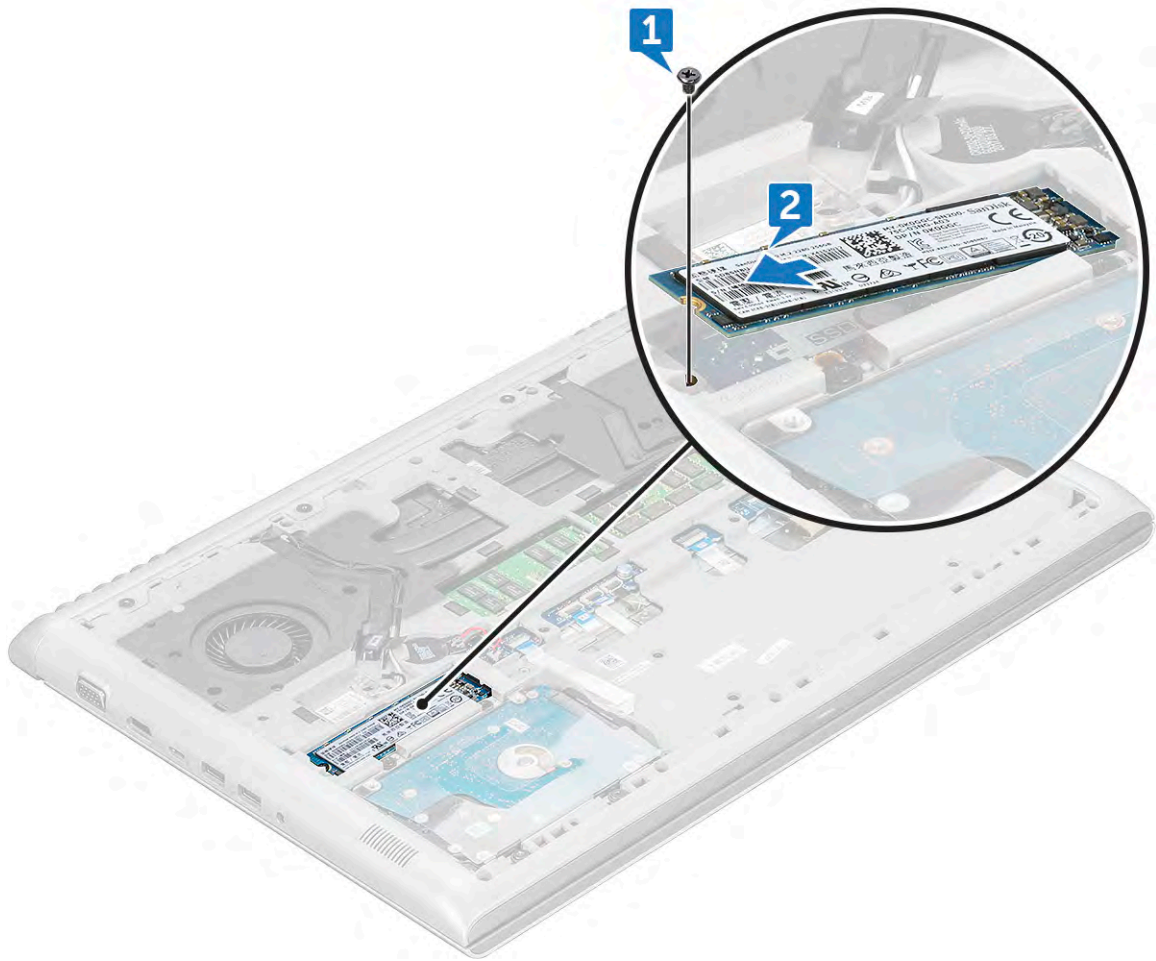

## Installing the M.2 Solid State Drive — SSD

- 1 Insert the SSD into the connector on the system.
- 2 Replace the M2x3 screw to secure the SSD to the system.
- 3 Install the:
  - a [battery](#)
  - b [base cover](#)
- 4 Follow the procedure in [After working inside your computer](#).

## WLAN card

### Removing the WLAN card

- 1 Follow the procedure in [Before working inside your computer](#).
- 2 Remove the:
  - a [base cover](#)
  - b [battery](#)
- 3 To remove the WLAN card:
  - a Remove the single (M2x3) screw that secures the wireless card holder to the system [1].
  - b Remove the wireless card holder that secures the WLAN antenna cables [2].

- c Disconnect the WLAN antenna cables from the connectors on the WLAN card [3].
- d Lift the WLAN card away from the system [4].

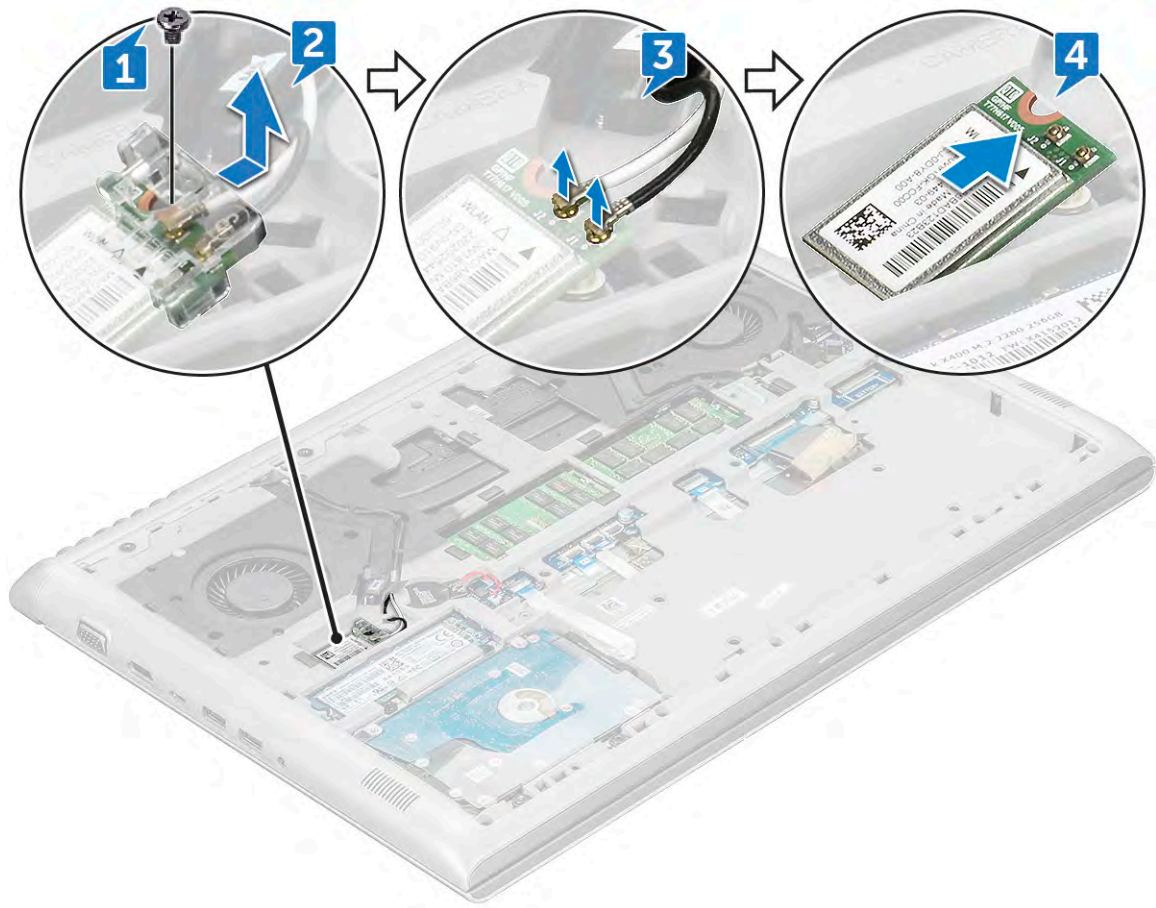

## Installing the WLAN card

- 1 Insert the WLAN card into the slot on the system.
- 2 Connect the WLAN antenna cables to the connectors on the WLAN card.
- 3 Place the wireless card holder to its place and replace the M2x3 screw to secure the holder to the system.
- 4 Install the:
  - a battery
  - b base cover
- 5 Follow the procedure in [After working inside your computer](#).

## Rear cover

### Removing the rear cover

- 1 Follow the procedure in [Before working inside your computer](#).
- 2 Remove the:
  - a base cover
  - b battery
- 3 To remove the screws:
  - a Remove the four M2x2 screws that secure the rear cover to the system [1].



- b Pry the rear cover from the edge, starting from the two recess points near the center of the rear cover [2].

**NOTE:** You may need a plastic scribe to pry the rear cover from the edge.

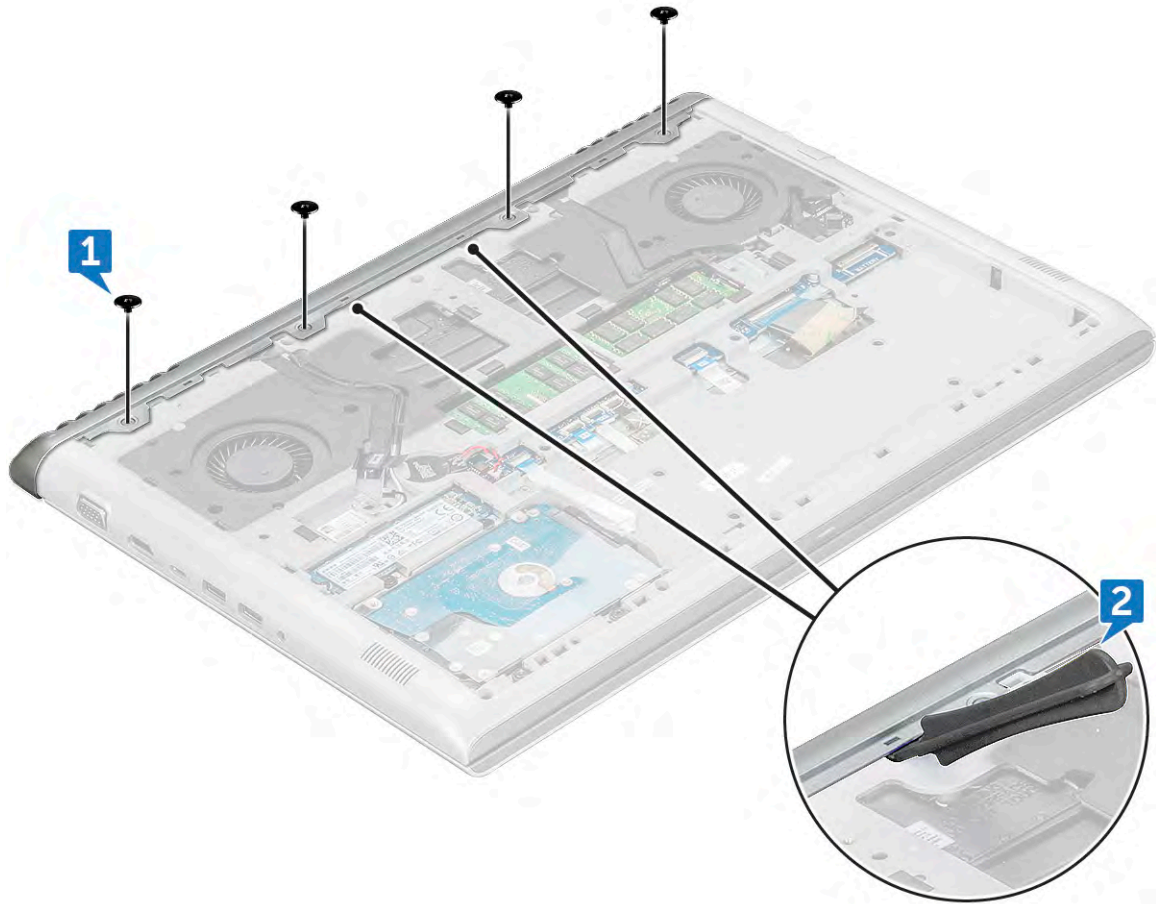

- 4 Pry the edges from the left and right side until the retention tabs are released.

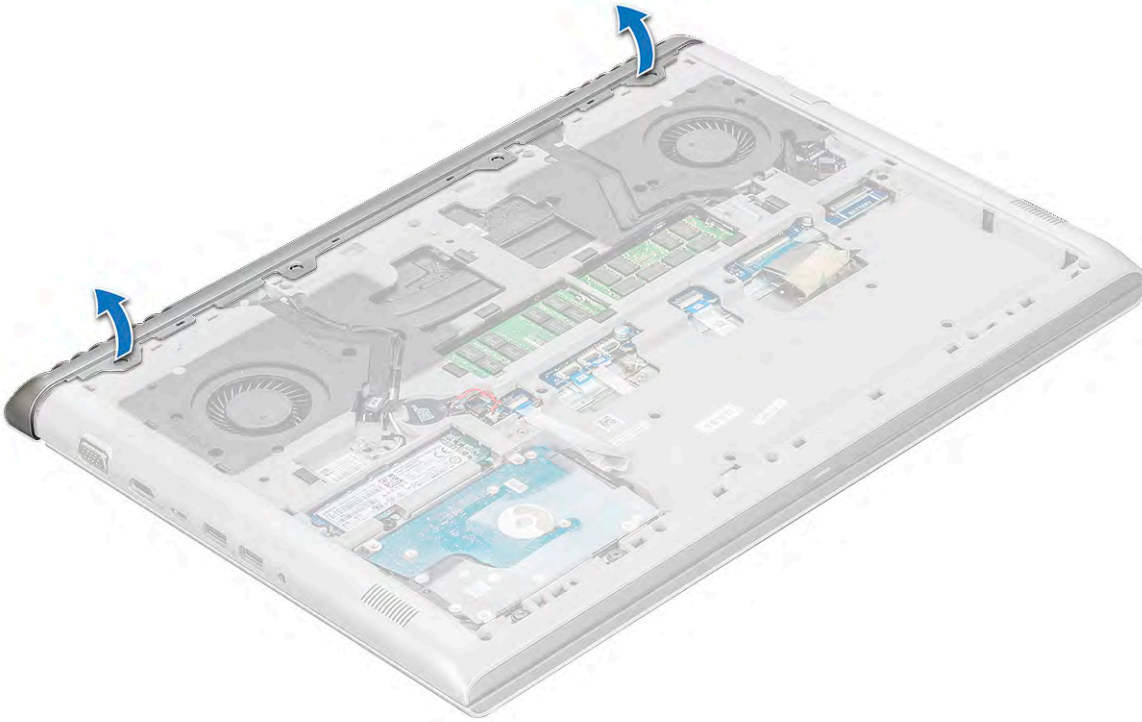

- 5 Remove the rear cover from the system.

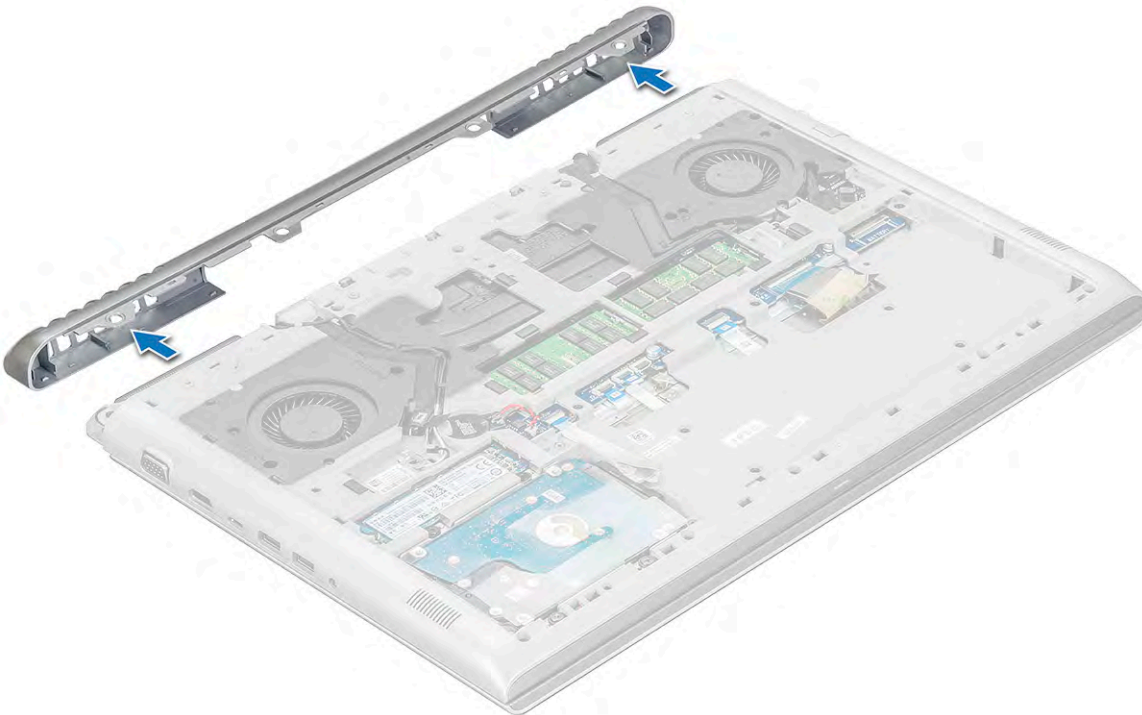

## Installing the rear cover

- 1 Press the edges of the rear cover until it clicks into place.
- 2 Replace the M2x2 screws that secure the rear cover to the system.



- 3 Install the:
  - a battery
  - b base cover
- 4 Follow the procedure in [After working inside your computer](#).

## Back cover

### Removing the back cover

- 1 Follow the procedure in [Before working inside your computer](#).
- 2 Remove the:
  - a base cover
  - b battery
  - c WLAN card
  - d rear cover
- 3 To disconnect the cables:
  - a Disconnect the camera cable and unroute from the routing channel [1, 2].
  - b Unroute the WLAN antenna cables from the routing channel [3, 4].

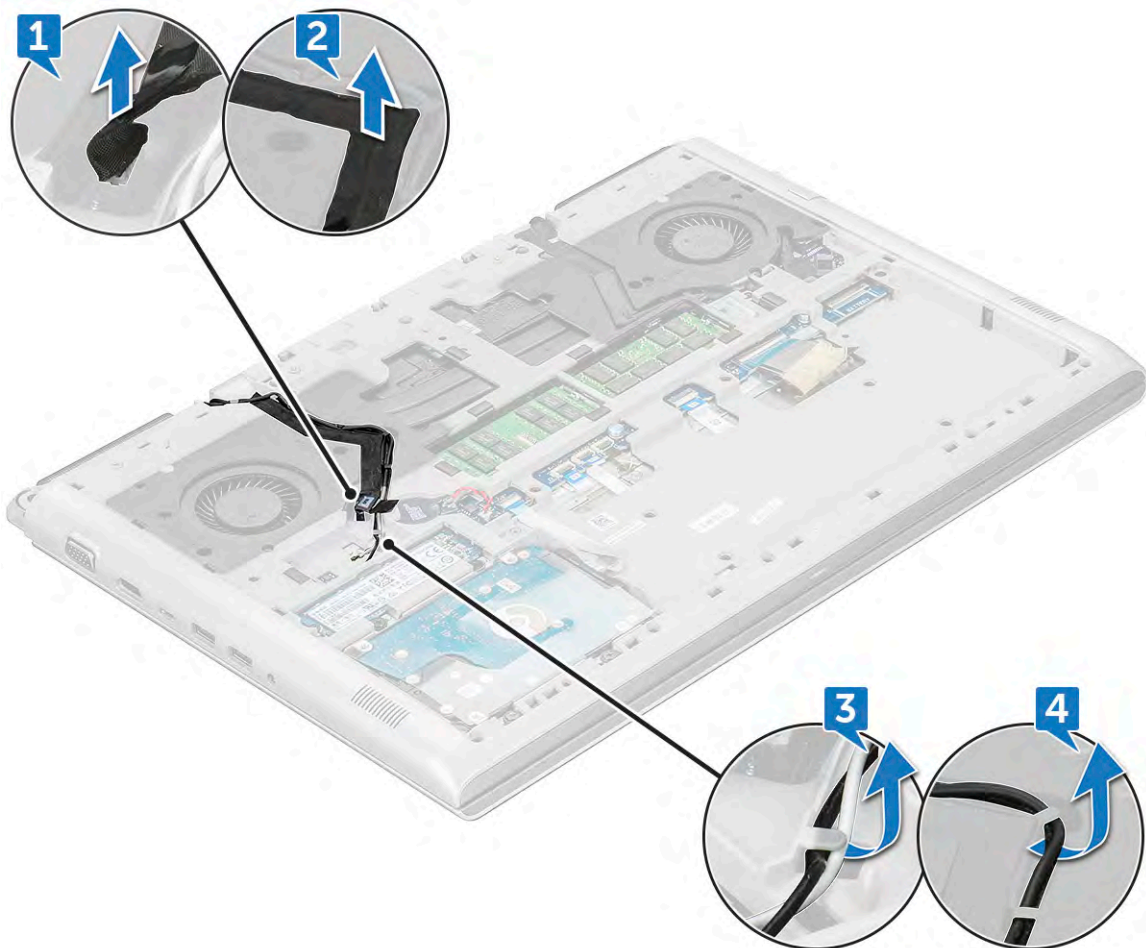

- 4 Disconnect the eDP cable:
  - a Remove the single (M2x3)screw that secures the eDP metal bracket to the system [1].
  - b Lift the eDP metal tab from the system [2].
  - c Disconnect the eDP cable from the connector on the system board [3].

d Unroute the eDP cable from the routing channel [4].

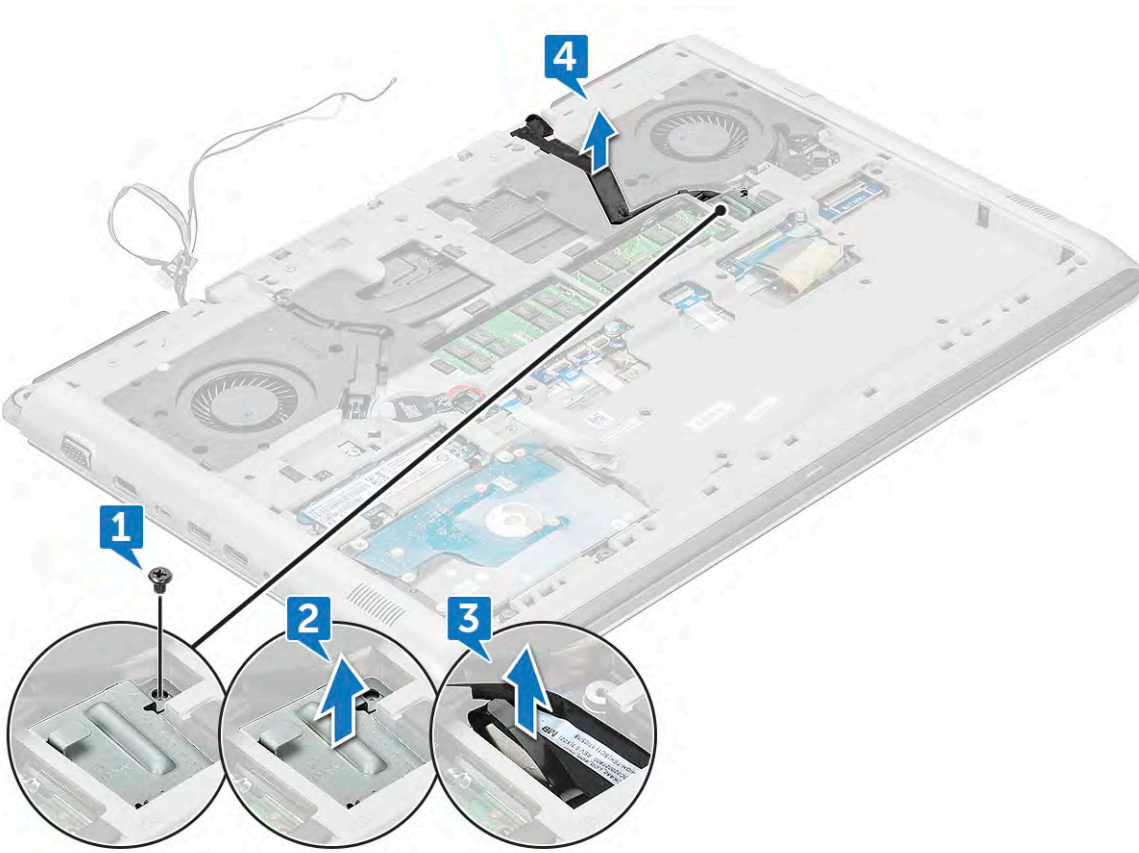

5 Disconnect the following cables:

- a Disconnect the Power, LED and Keyboard backlight cable from the connector on the system board [1].
- b Disconnect the touchpad cable from the connector on the system board [2].
- c Peel the adhesive tape and disconnect the keyboard cable from the connector on the system board [3, 4].

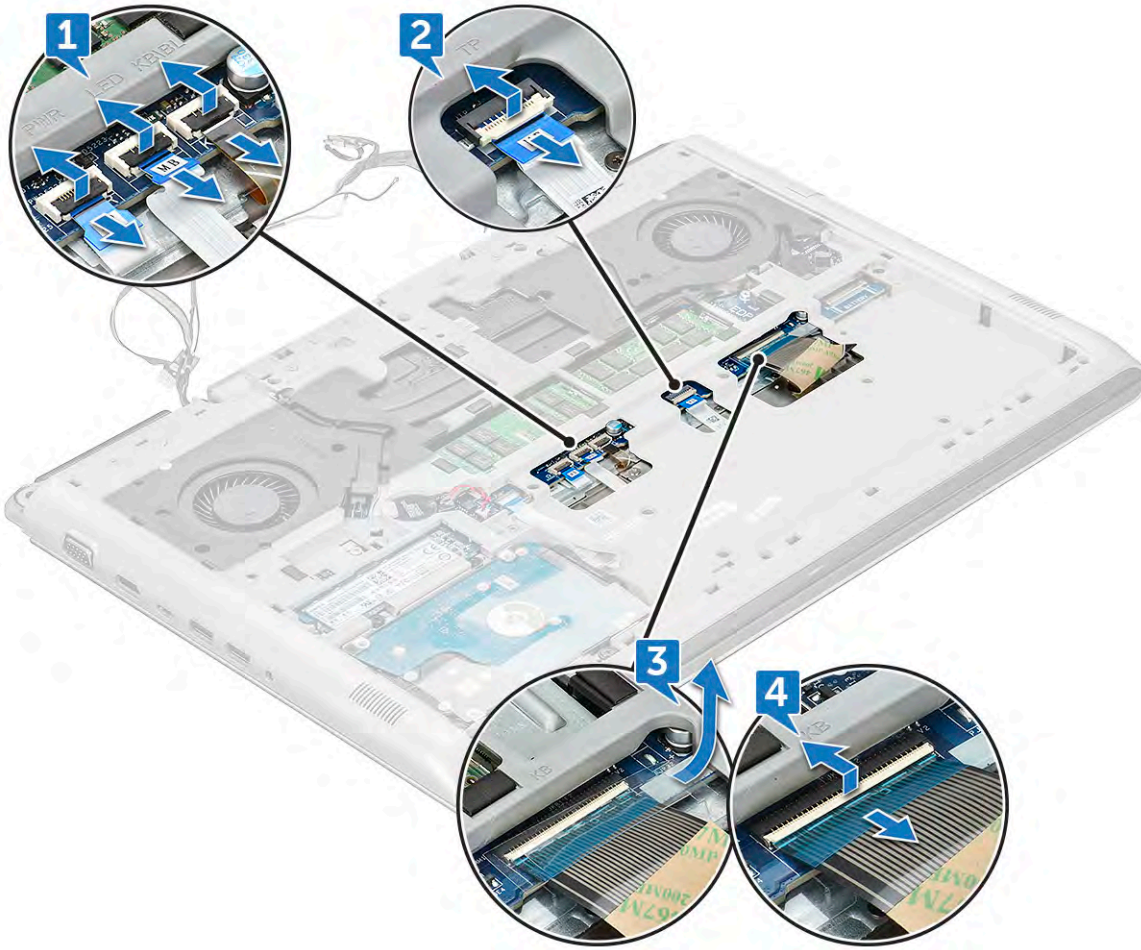

6 Remove the nineteen (M2.5x6) screws that secure the back cover to the system.

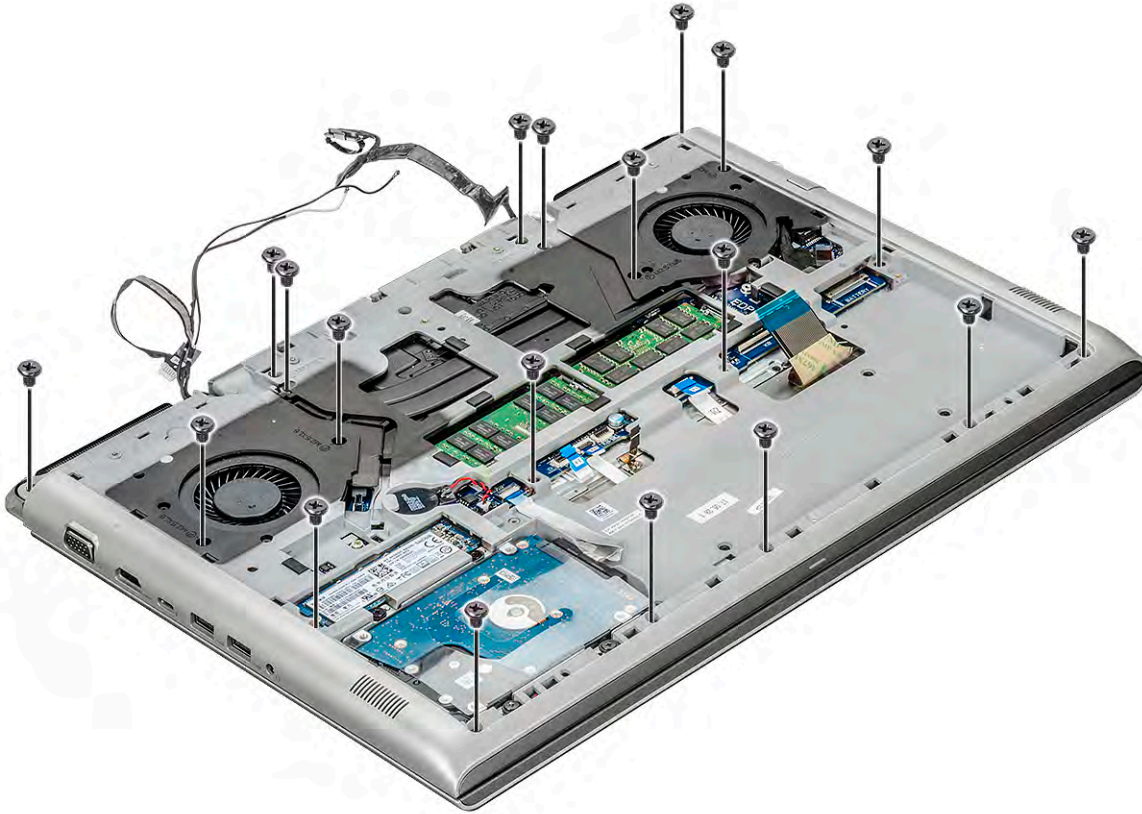

7 Remove the four (M2x3) screws and turn over the system [1, 2].

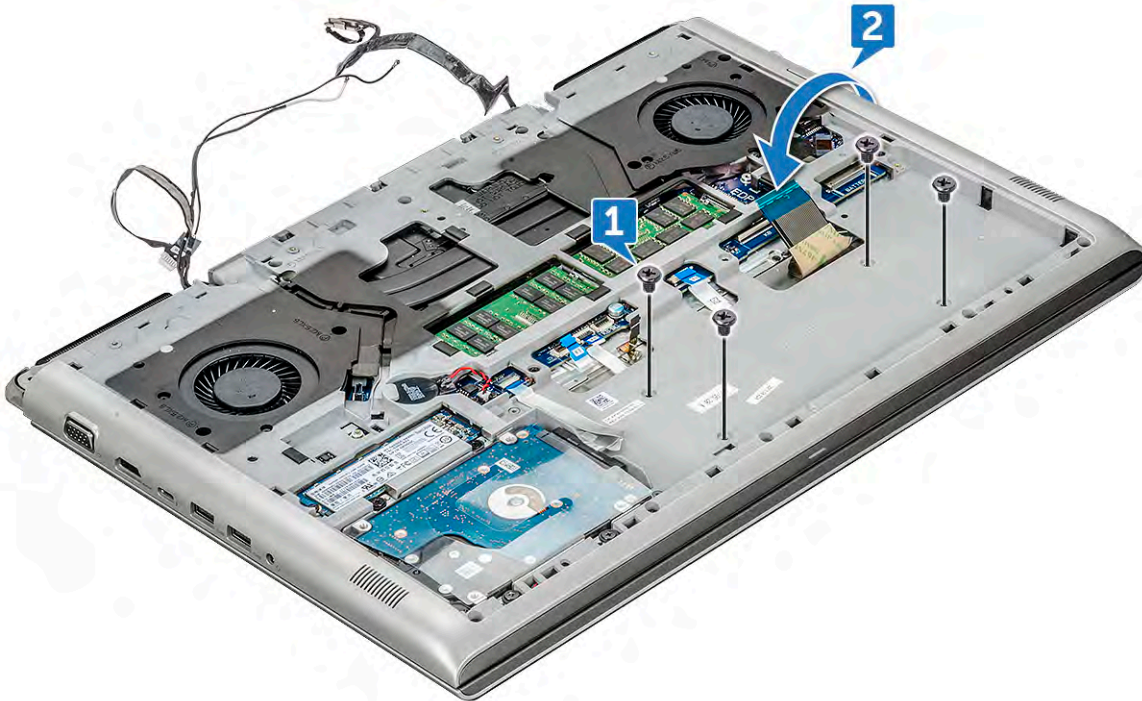

8 Open the display assembly at 90° angle.

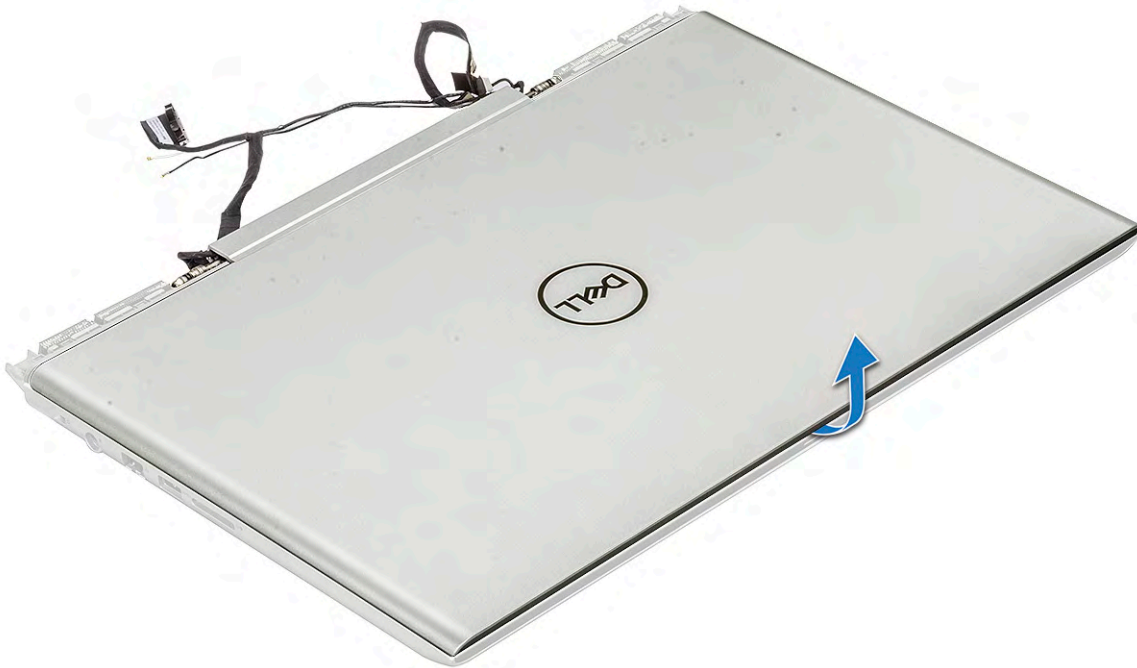

- 9 To remove the back cover:
  - a Using a plastic scribe, pry the edges of the palmrest [1, 2].
  - b Lift the palmrest away from the back cover [3].

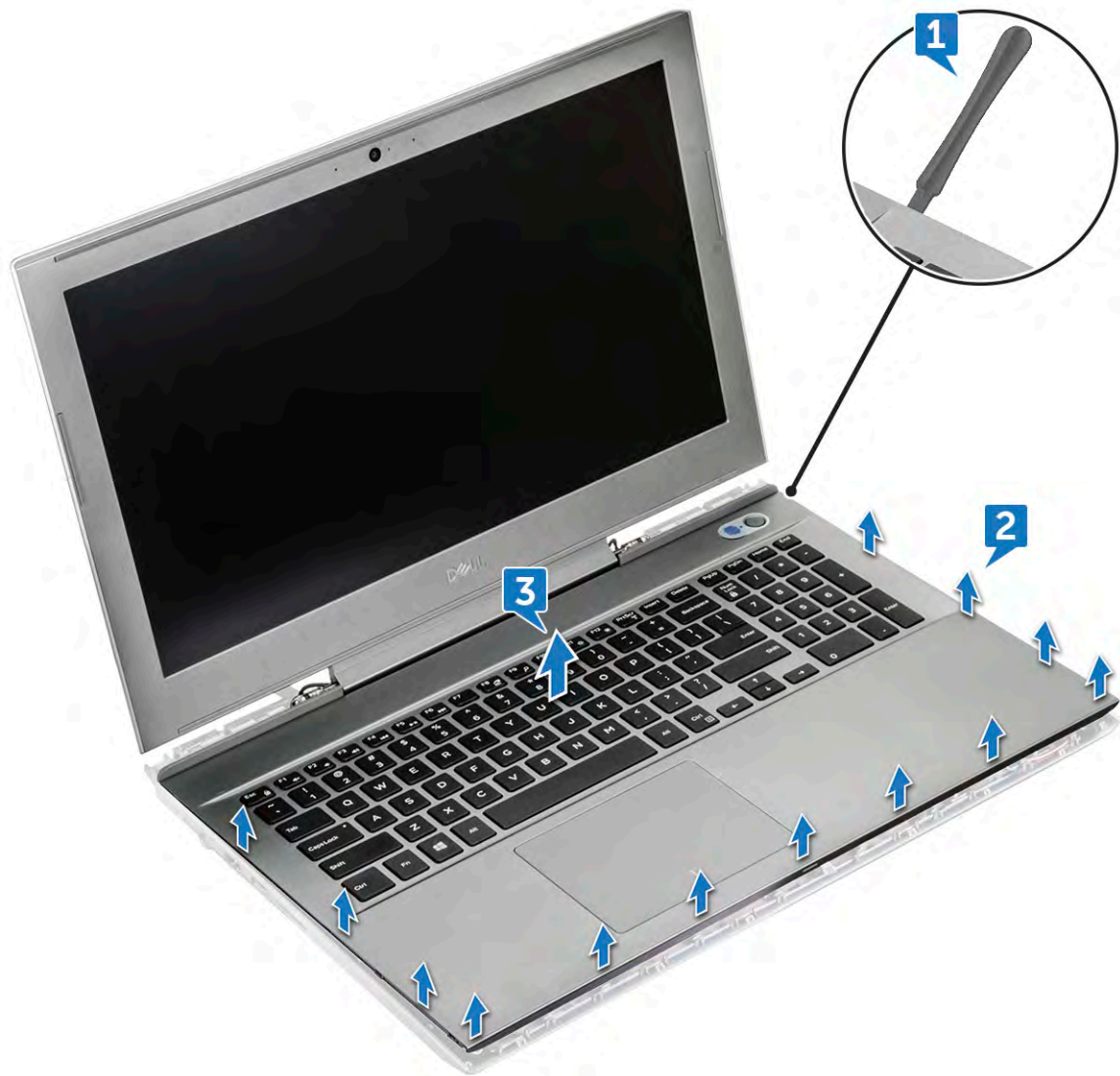

10 The component you are left with is the back cover.



**NOTE:** For complete replacement of the back cover, the following parts need to be removed: the Memory, System Board, Speakers and DC-In cable.

## Installing the back cover

- 1 Press the edges of the back cover until it clicks into place.
- 2 Close the display assembly and turn over the system.
- 3 Replace the four (M2x3) and nineteen (M2.5x6) screws to secure the back cover to the system.
- 4 Connect the power, LED and Keyboard backlight cable, touchpad cable, keyboard cable to the connectors in the system board and affix the adhesive tape over the keyboard cable.
- 5 Route the eDP cable through the routing channel and connect the cable to the system.
- 6 Place the eDP metal bracket and replace the M2x3 screw to secure the eDP to the system.
- 7 Route the camera and WLAN antenna cables through the routing channel and connect the camera cable to the system board.
- 8 Install the:
  - a WLAN card
  - b rear cover
  - c battery
  - d base cover
- 9 Follow the procedure in [After working inside your computer](#).

## Speaker

### Removing the speaker

- 1 Follow the procedure in [Before working inside your computer](#).
- 2 Remove the:
  - a base cover
  - b battery

- c SSD card
- d WLAN card
- e HDD
- f memory module
- g rear cover
- h back cover

- 3 To remove the speaker:
- a Disconnect the speaker cable from the connector in the system board [1].
  - b Unroute the cable from the routing channel [2, 3, 4].

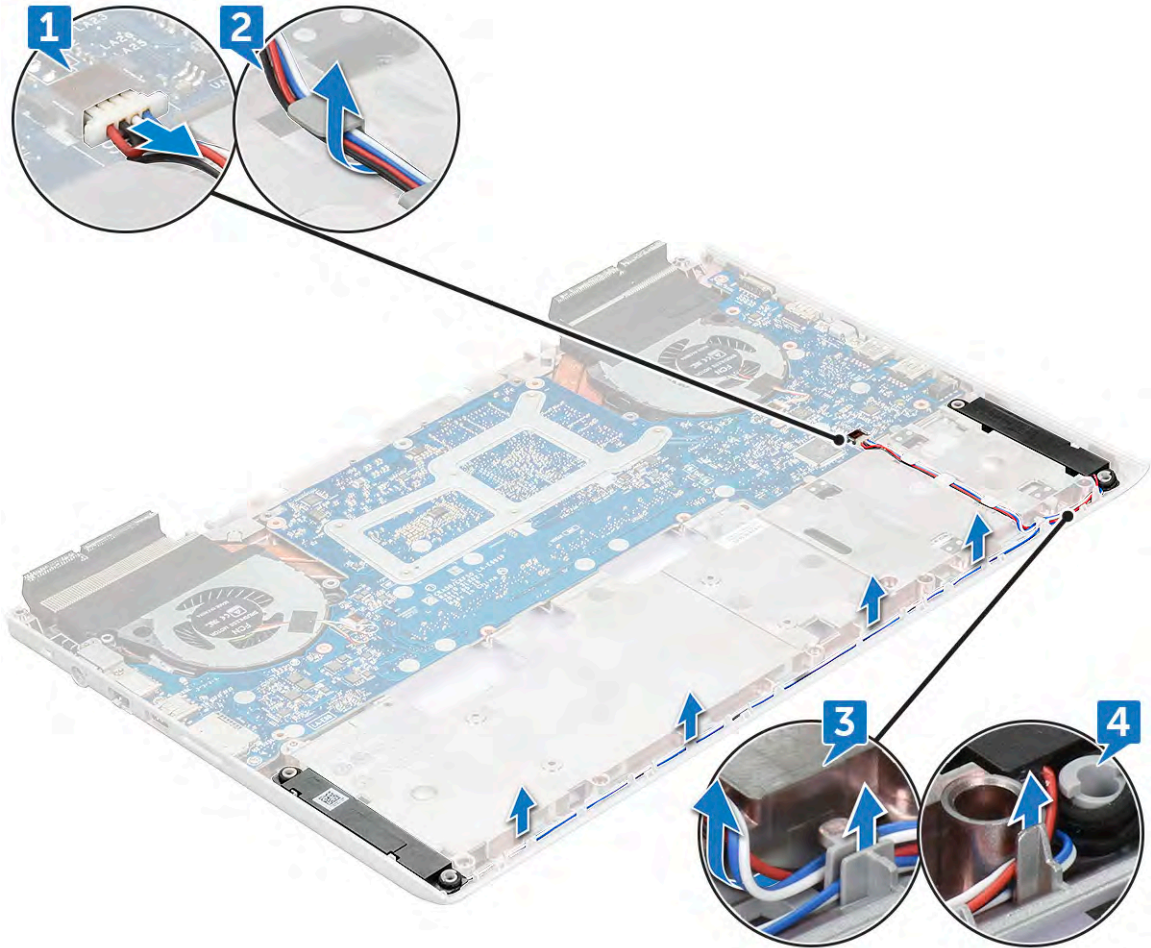

- 4 Lift the speakers, along with the speaker cable, away from the back cover.

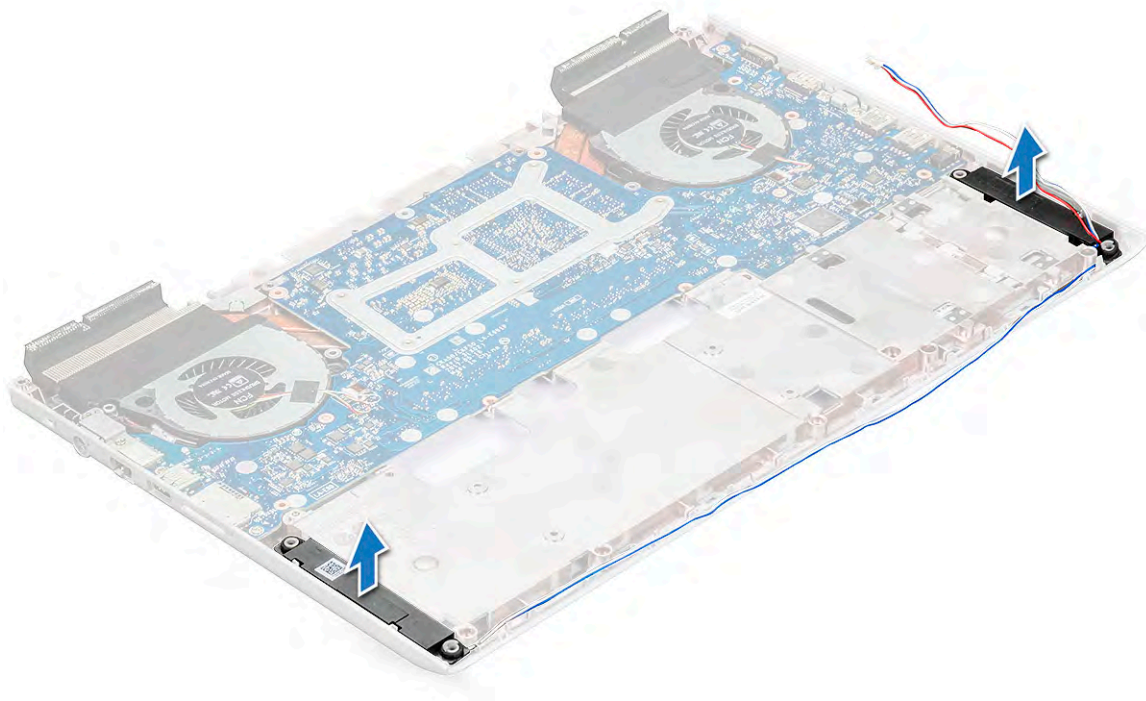

## Installing the speaker

- 1 Align the speakers along the slots on the system.
- 2 Route the speaker cable through the routing tabs on the system.
- 3 Connect the speaker cable to the connector in the system board.
- 4 Install the:
  - a back cover
  - b rear cover
  - c memory module
  - d WLAN card
  - e hard drive
  - f SSD card
  - g battery
  - h base cover
- 5 Follow the procedure in [After working inside your computer](#).

## System board

### Removing the system board

- 1 Follow the procedure in [Before working inside your computer](#).
- 2 Remove the:
  - a base cover
  - b battery
  - c SSD card
  - d WLAN card
  - e HDD
  - f memory module

- g rear cover
- h back cover

3 Disconnect the following cables:

- a Disconnect the coin cell battery cable from the connector on the system board [1].
- b Disconnect the hard drive cable from the connector on the system board [2].
- c Disconnect the DC-in connector from the system board [3].

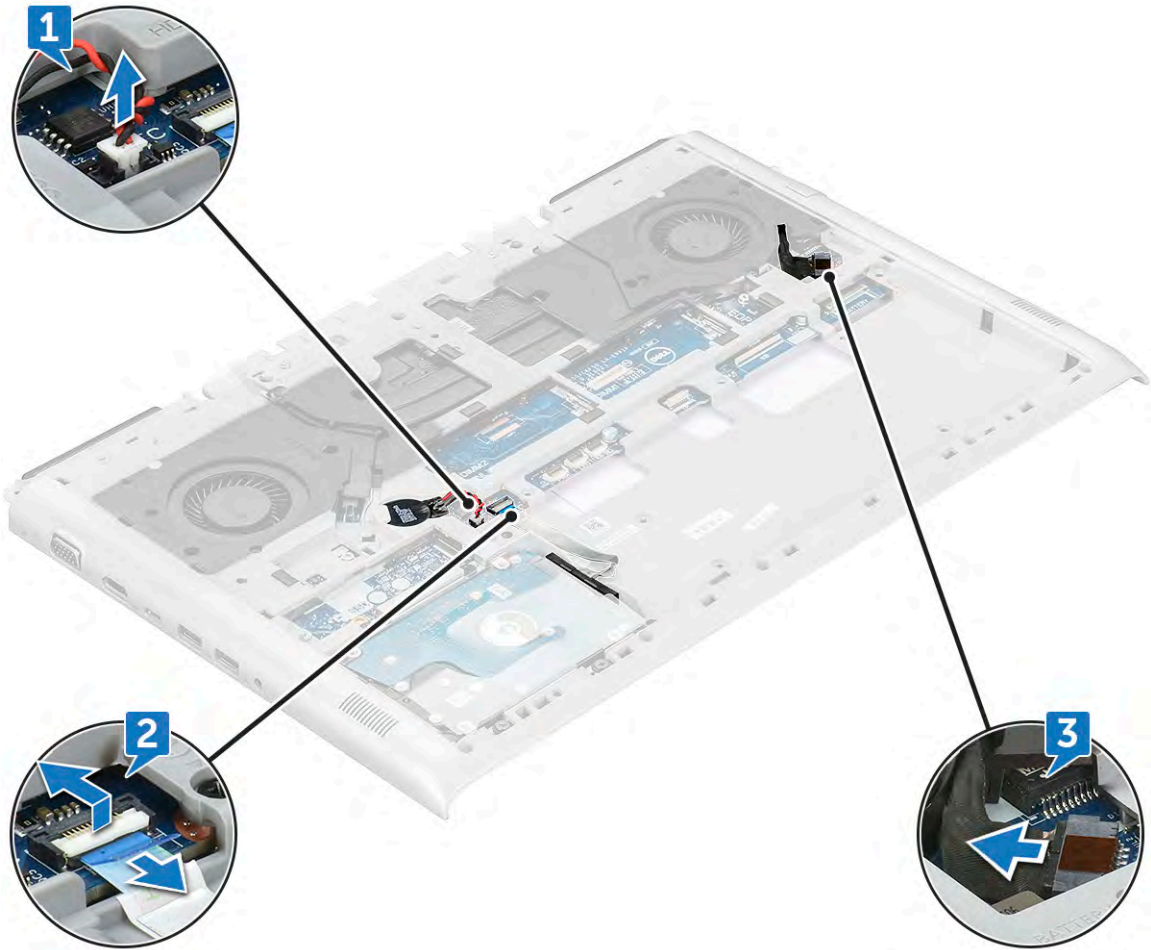

4 Remove the following metal tabs:

- a Remove the two (M2.5x5) screws that secure the DC-in metal bracket on the system board [1].
- b Lift the metal bracket that secures the power port on the system board [2].
- c Remove the two (M2.5x5) screws that secure the Type-C USB metal bracket on the system board [3].
- d Lift the Type-C USB metal bracket that secures the Thunderbolt port on the system board [4].
- e Disconnect the speaker cable from the system board [5].

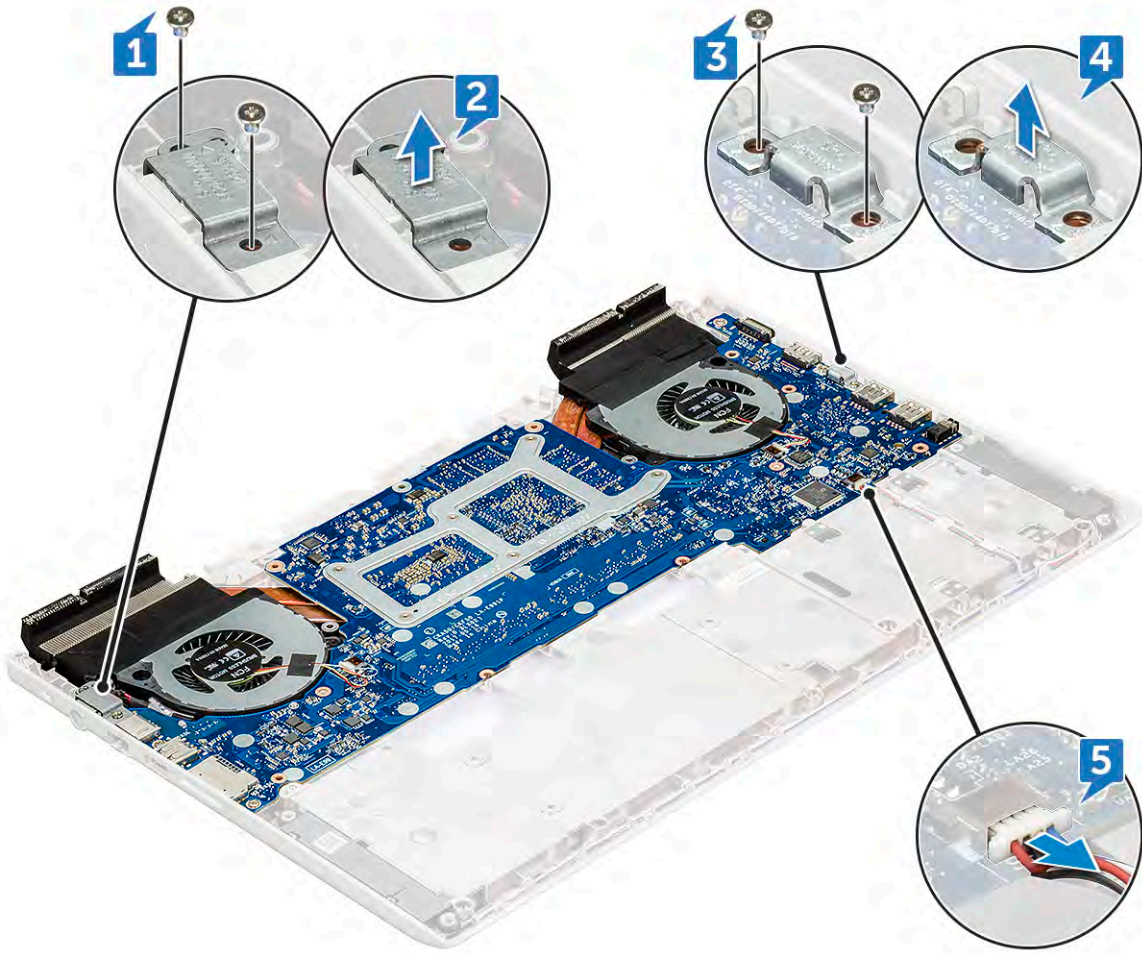

5 Remove the four (M2x3) screws that secure the system fan to the system board.



- 6 To remove the system board:
  - a Remove the three (M2.5x5) screws that secure the system board to the system [1].
  - b Carefully lift the left side of the system board and remove the system board from the system [2].



**NOTE:** For complete replacement of the system board the heatsink needs to be removed.

## Installing the system board

- 1 Align the system board into its original position on the system.
- 2 Replace the three (M2.5x5) screws to secure the system board to the system.
- 3 Replace the four (M2x3) screws that secure the system fan to the system board.
- 4 Connect the speaker cable to the system board.
- 5 Place the Type-C USB metal bracket on the Thunderbolt port and replace the two (M2.5x5) screws that secure the metal bracket to the system board.
- 6 Place the DC-in metal bracket on the power port and replace the two (M2.5x5) screws that secure the metal bracket to the system board.
- 7 Connect the coin cell battery and hard drive cable to the connector on the system board.
- 8 Install the:
  - a back cover
  - b rear cover
  - c memory module
  - d WLAN card
  - e HDD
  - f SSD card
  - g battery
  - h base cover
- 9 Follow the procedure in [After working inside your computer](#).

# Power connector port

## Removing the power connector port

- 1 Follow the procedure in [Before working inside your computer](#).
- 2 Remove the:
  - a [base cover](#)
  - b [battery](#)
  - c [SSD card](#)
  - d [WLAN card](#)
  - e [HDD](#)
  - f [memory module](#)
  - g [rear cover](#)
  - h [back cover](#)
  - i [system board](#)
- 3 To remove power connector port:
  - a Unroute the power connector port from the routing channel [1].
  - b Remove the power connector port from the system [2].



## Installing the power connector port

- 1 Place the power connector port on the system.
- 2 Route the power connector port cable through the routing channels on the system.
- 3 Install the:
  - a [system board](#)
  - b [back cover](#)
  - c [rear cover](#)
  - d [memory module](#)
  - e [WLAN card](#)
  - f [HDD](#)
  - g [SSD card](#)
  - h [battery](#)
  - i [base cover](#)
- 4 Follow the procedure in [After working inside your computer](#).

## Heat sink

### Removing the heat sink assembly

- 1 Follow the procedure in [Before working inside your computer](#).
- 2 Remove the:
  - a [base cover](#)
  - b [battery](#)
  - c [SSD card](#)
  - d [WLAN card](#)
  - e [HDD](#)
  - f [memory module](#)
  - g [rear cover](#)
  - h [back cover](#)
- 3 Disconnect the left fan cable [1] and right fan cable [2] from the connectors on the system board.



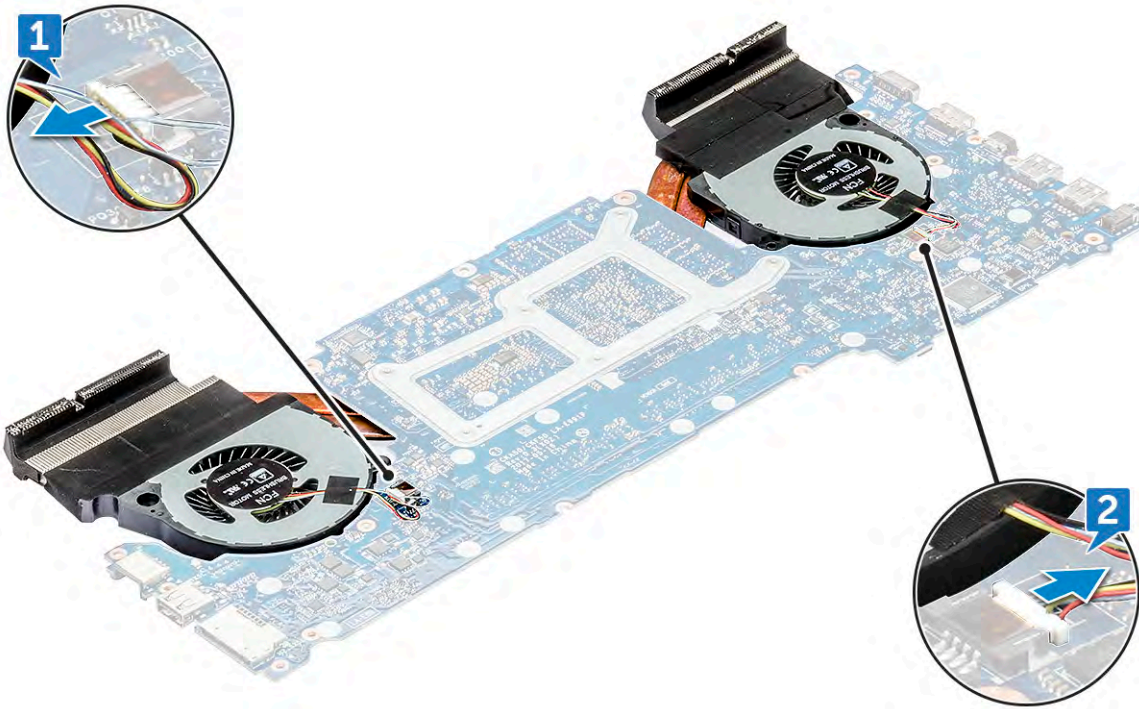

- 4 To remove the heat sink assembly:
- a Turn over the system board and remove the six (M2x3) screws (6 > 5 > 4 > 3 > 2 > 1) that secure the heat sink assembly to the system board [1].
  - NOTE:** Remove the screws based on the numbering on the heat sink.
  - b Lift the heat sink assembly from the system board [2].

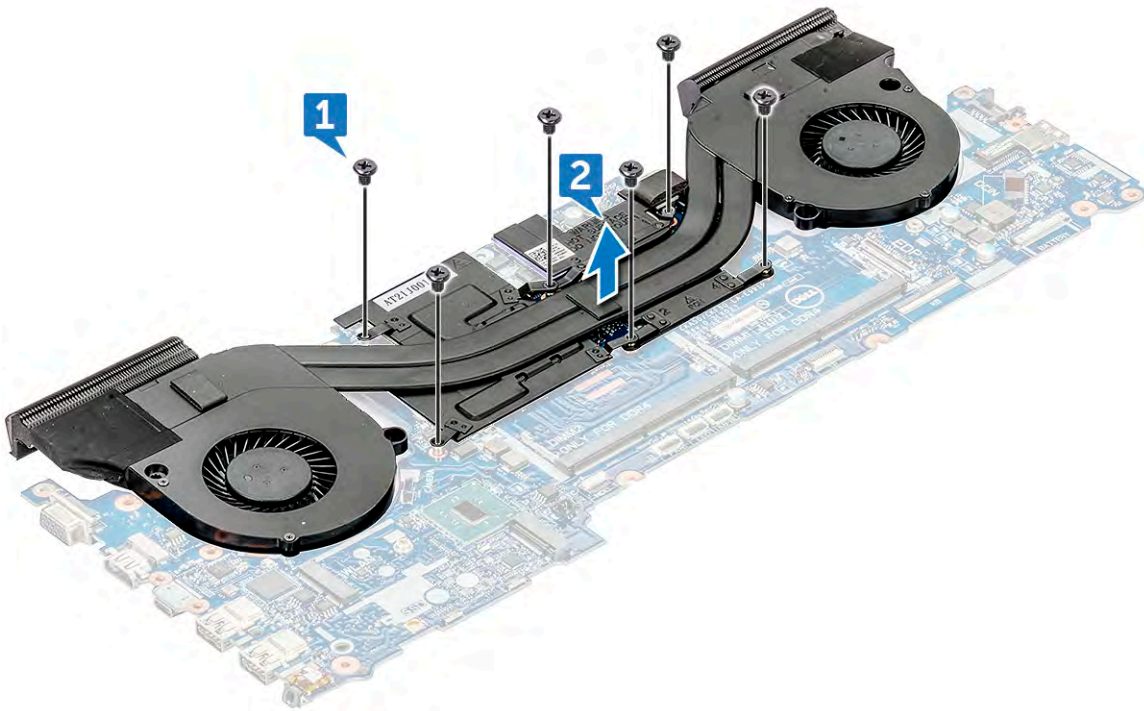

- 5 The component you are left with is the heat sink assembly.

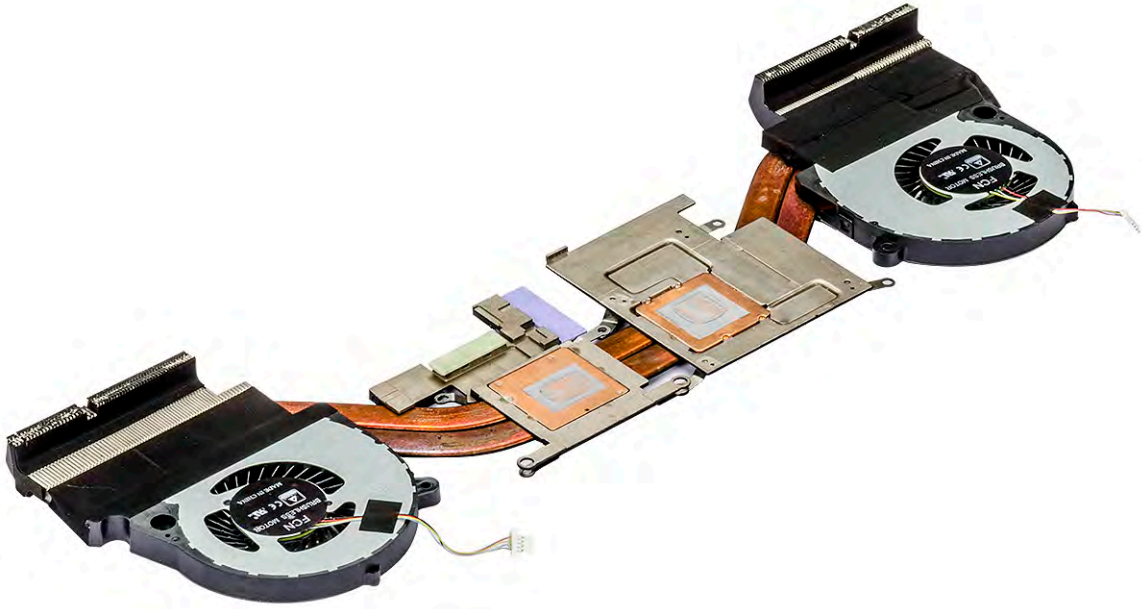

## Installing the heat sink assembly

- 1 Replace the heat sink assembly on the system board.
- 2 Replace the six M2x3 screws to secure the heat-sink assembly to the system board.

**NOTE:** Tighten the screws based on the order mentioned in the removal procedure.

- 3 Turn over the system board.
- 4 Connect the two fan cables to the connector on the system board.
- 5 Install the:

- a back cover
- b rear cover
- c memory module
- d SSD card
- e WLAN card
- f HDD
- g battery
- h base cover

- 6 Follow the procedure in [After working inside your computer](#).

## Touchpad

### Removing the touchpad

- 1 Follow the procedure in [Before working inside your computer](#).
- 2 Remove the:
  - a base cover
  - b battery
  - c SSD card
  - d WLAN card
  - e HDD
  - f memory module



- g rear cover
- h back cover

- 3 Remove the four (M2x2) screws that secure the touchpad assembly to the palmrest [1].
- 4 Slide the touchpad assembly from the display assembly [2].

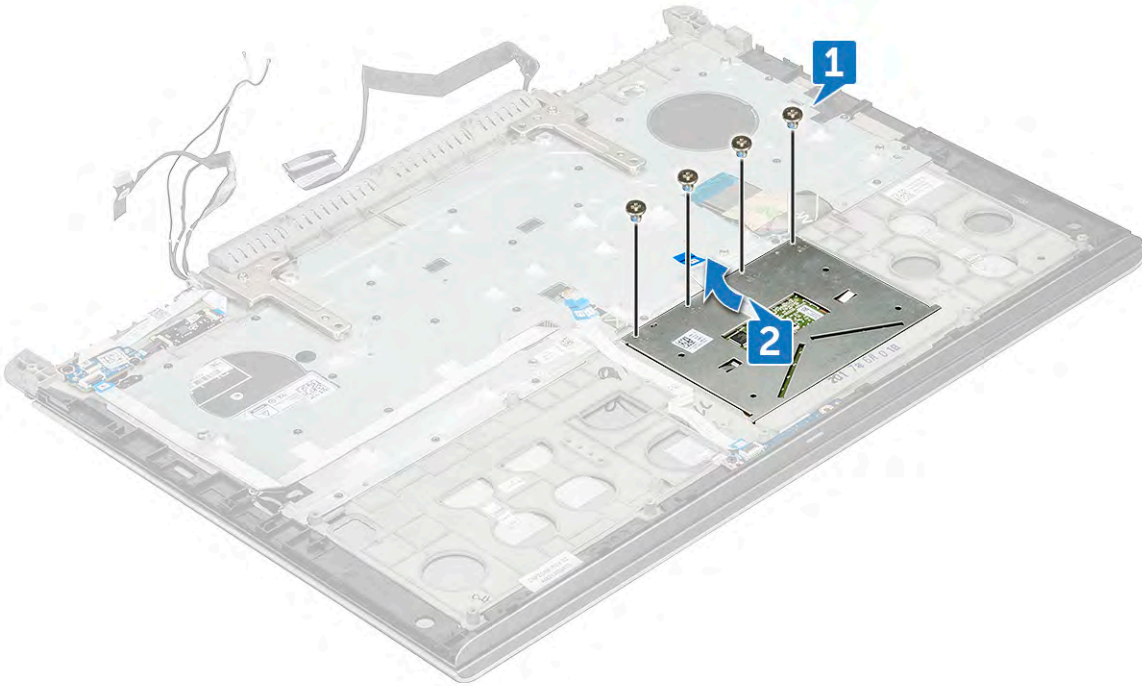

- 5 Lift the touchpad assembly from the palmrest.

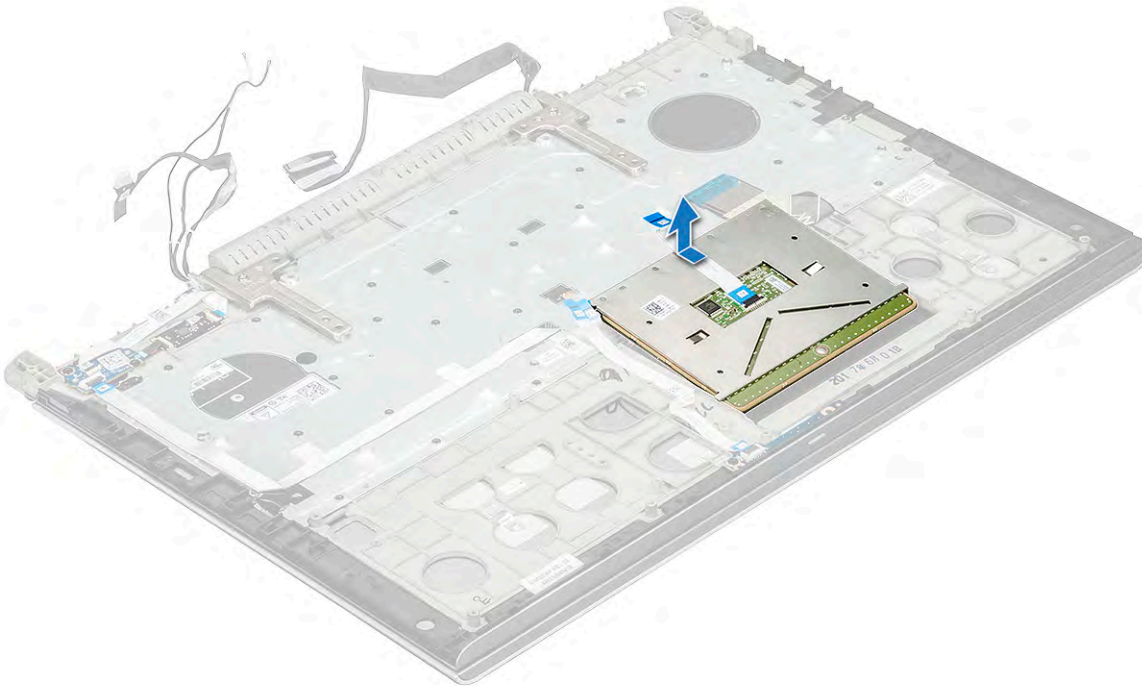

# Installing the touchpad

- 1 Place the touchpad assembly into the slot on the system.
- 2 Replace the four (M2x2) screws that secure the touchpad assembly to the system.
- 3 Install the:
  - a [back cover](#)
  - b [rear cover](#)
  - c [memory module](#)
  - d [WLAN card](#)
  - e [HDD](#)
  - f [SSD card](#)
  - g [battery](#)
  - h [base cover](#)
- 4 Follow the procedure in [After working inside your computer](#).

# LED board

## Removing the LED board

- 1 Follow the procedure in [Before working inside your computer](#).
- 2 Remove the:
  - a [base cover](#)
  - b [battery](#)
  - c [SSD card](#)
  - d [WLAN card](#)
  - e [HDD](#)
  - f [memory module](#)
  - g [rear cover](#)
  - h [back cover](#)
- 3 To remove LED board:
  - a Lift the latch and disconnect the LED board cable [1].
  - b Remove the single (M2x3) screw that secures the LED board cable to the display assembly [2].
  - c Slide and lift the LED board from the display assembly [3].



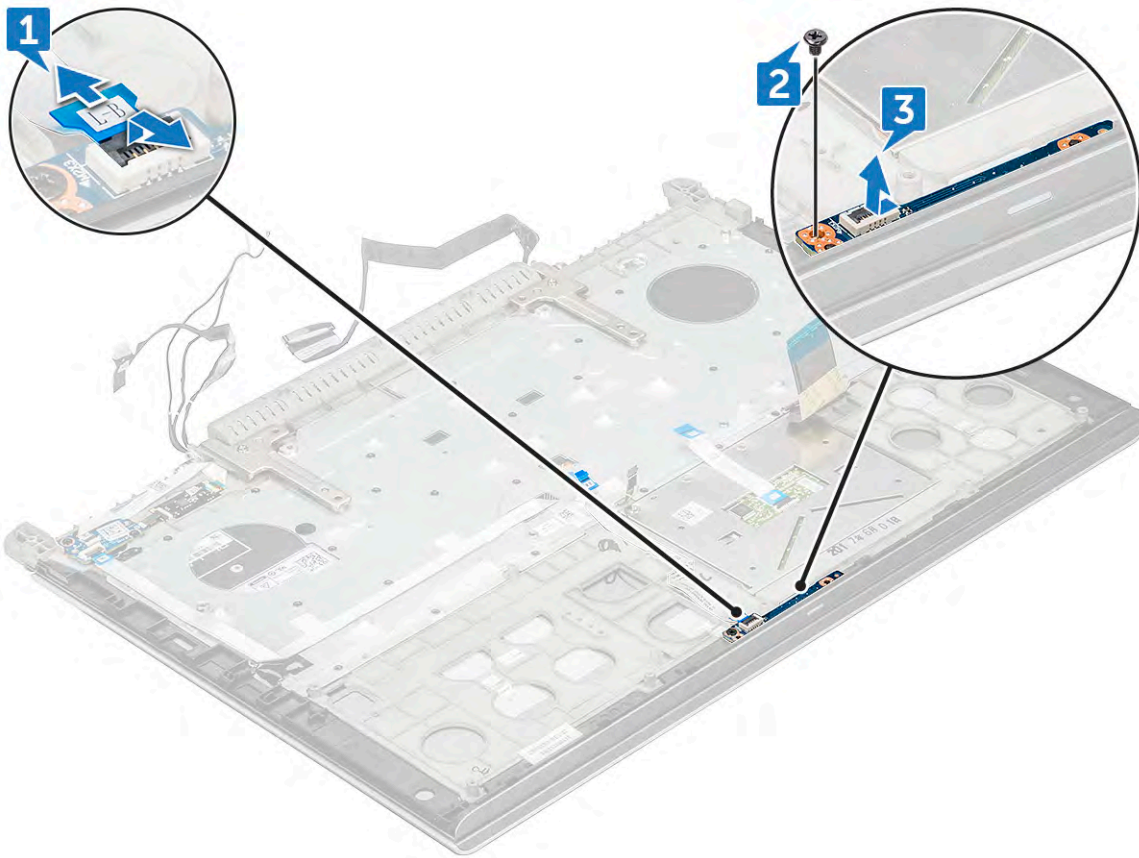

## Installing the LED board

- 1 Place the LED board into the slot on the display assembly.
- 2 Replace the single (M2x3) screw that secures the LED board on the display assembly.
- 3 Connect the LED board cable to the display assembly.
- 4 Install the:
  - a [back cover](#)
  - b [rear cover](#)
  - c [memory module](#)
  - d [WLAN card](#)
  - e [HDD](#)
  - f [SSD card](#)
  - g [battery](#)
  - h [base cover](#)
- 5 Follow the procedure in [After working inside your computer](#).

## Power button board

### Removing the power button board

- 1 Follow the procedure in [Before working inside your computer](#).
- 2 Remove the:
  - a [base cover](#)

- b battery
- c SSD card
- d WLAN card
- e HDD
- f memory module
- g rear cover
- h back cover

3 To release the power button board:

- a Lift the latch and disconnect the power button board cable from the power button board [1].
- b Peel the adhesive tape that covers the power button board cable [2] and pry the power button board cable from the palmrest.

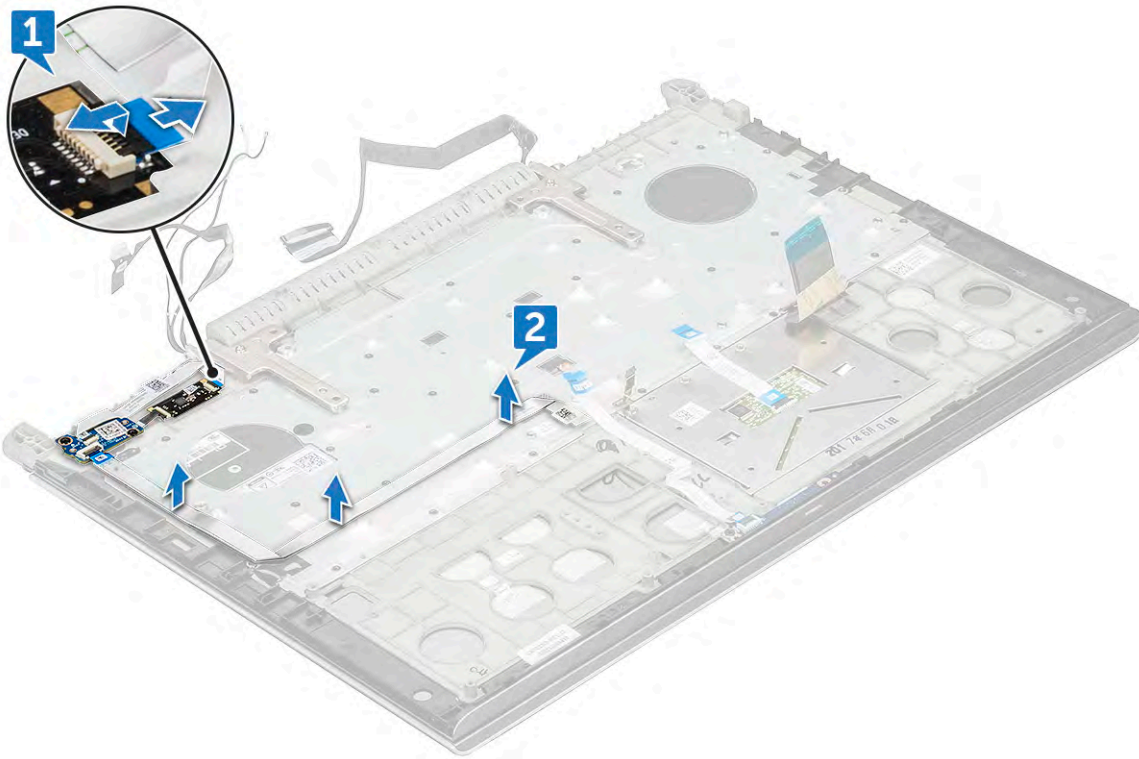

4 To remove power button board:

- a Remove the two (M2x3) screws that secure the power button board to the palmrest [1].
- b Remove the power button board from the palmrest [2].

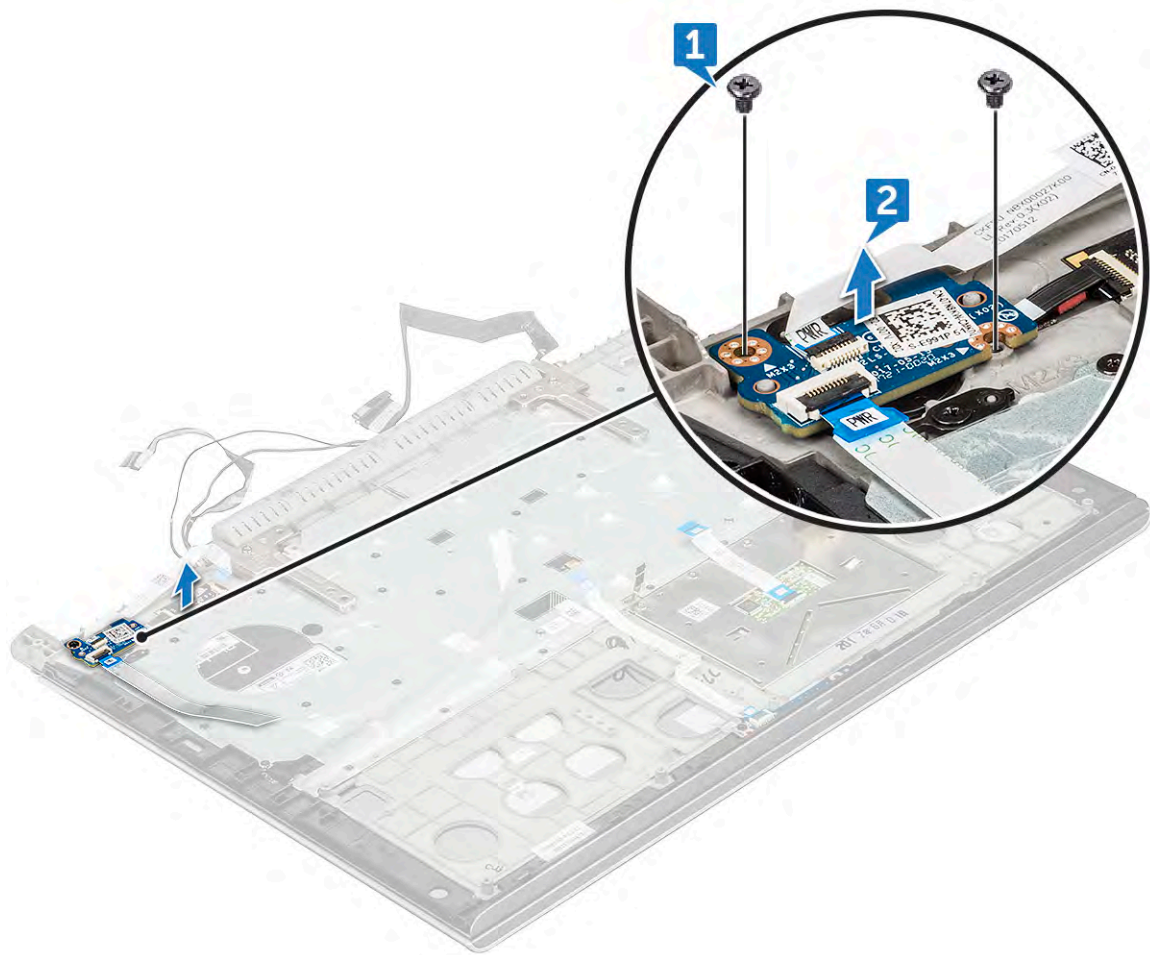

## Installing the power button board

- 1 Place the power button board into the slot on the palmrest.
- 2 Replace the two (M2x3) screw that secures the power button board to the display assembly.
- 3 Connect the power button board cable to the power button board and affix it to the palmrest.
- 4 Install the:
  - a [back cover](#)
  - b [rear cover](#)
  - c [memory module](#)
  - d [WLAN card](#)
  - e [HDD](#)
  - f [SSD card](#)
  - g [battery](#)
  - h [base cover](#)
- 5 Follow the procedure in [After working inside your computer](#).

# Fingerprint reader

## Removing the fingerprint reader

- 1 Follow the procedure in [Before working inside your computer](#).
- 2 Remove the:
  - a [base cover](#)
  - b [battery](#)
  - c [SSD card](#)
  - d [WLAN card](#)
  - e [HDD](#)
  - f [memory module](#)
  - g [rear cover](#)
  - h [back cover](#)
  - i [power button board](#)
- 3 To release the fingerprint reader:
  - a Using a plastic scribe lift the fingerprint reader board [1].
  - b Remove the two (M2x2) screws that secure the fingerprint reader to the palm rest [2].
  - c Lift the fingerprint reader away from the palm rest [3].

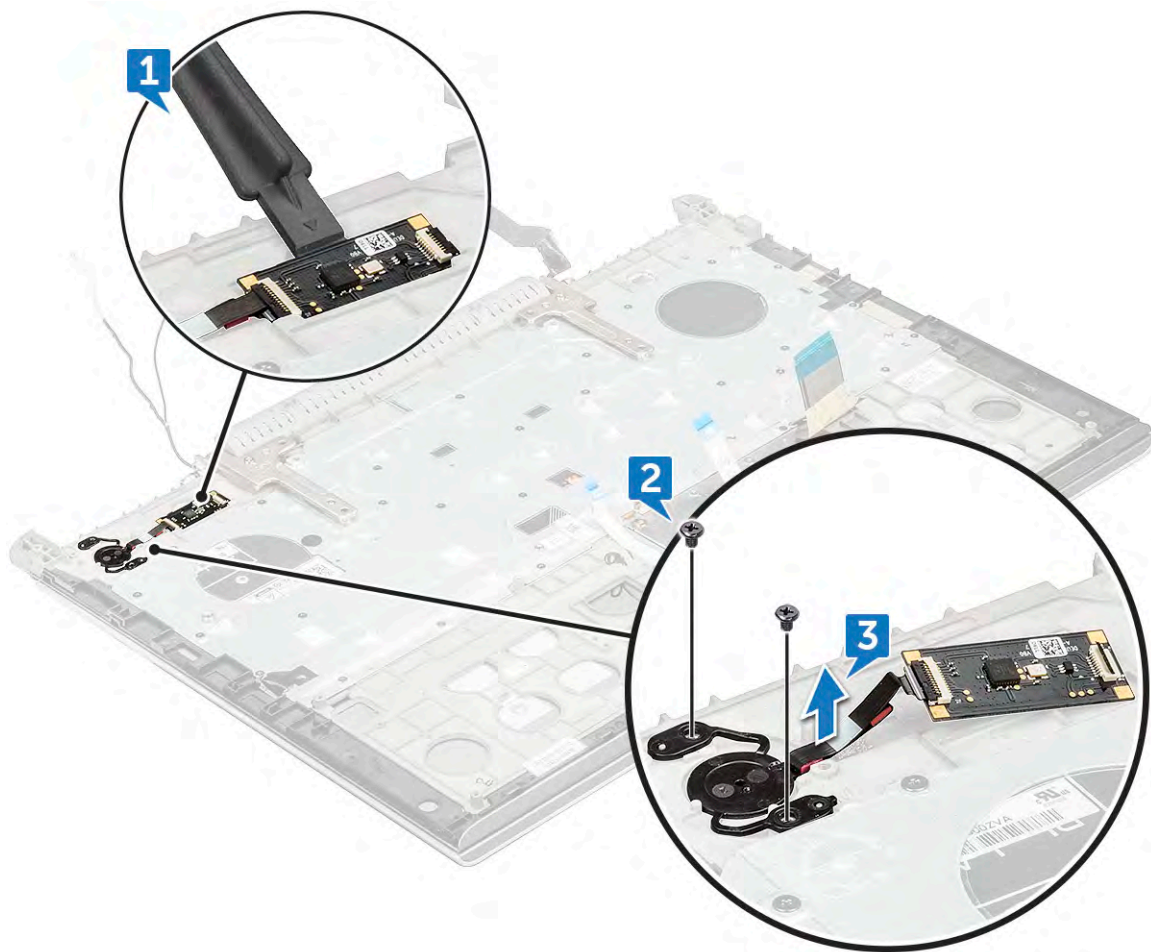

# Installing the fingerprint reader

- 1 Place the fingerprint reader into the slot on the palm rest.
- 2 Replace the two (M2x2) screws that secure fingerprint reader on the display assembly.
- 3 Install the:
  - a [power button board](#)
  - b [back cover](#)
  - c [rear cover](#)
  - d [memory module](#)
  - e [WLAN card](#)
  - f [HDD](#)
  - g [SSD card](#)
  - h [battery](#)
  - i [base cover](#)
- 4 Follow the procedure in [After working inside your computer](#).

## Keyboard

### Removing the keyboard

- 1 Follow the procedure in [Before working inside your computer](#).
- 2 Remove the:
  - a [base cover](#)
  - b [battery](#)
  - c [SSD card](#)
  - d [WLAN card](#)
  - e [HDD](#)
  - f [memory module](#)
  - g [rear cover](#)
  - h [back cover](#)
  - i [display hinge](#)
- 3 Disconnect the following cables:
  - a [power board cable](#)
  - b [LED board cable](#)
  - c [keyboard backlight cable](#)
  - d [touchpad cable](#)
  - e [keyboard cable](#)
- 4 Disconnect the power button board cable from the power button board and peel the power button board cable from the keyboard bracket [1, 3].
- 5 Peel the two pieces of black tape that covers the keyboard bracket [2, 5].

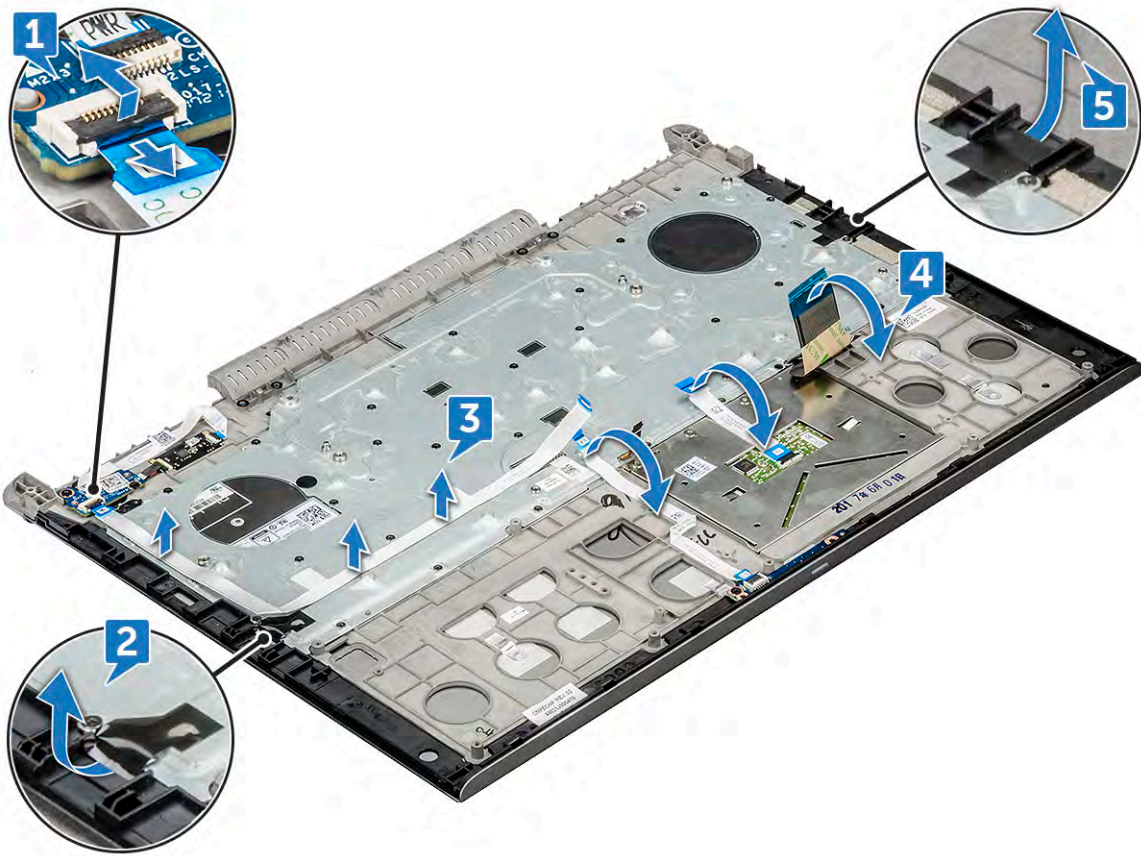

6 Remove the thirty (M1.6x2) screws that secure the keyboard bracket to the palmrest and lift the keyboard bracket [1, 2].



7 Remove the keyboard from the palm rest.

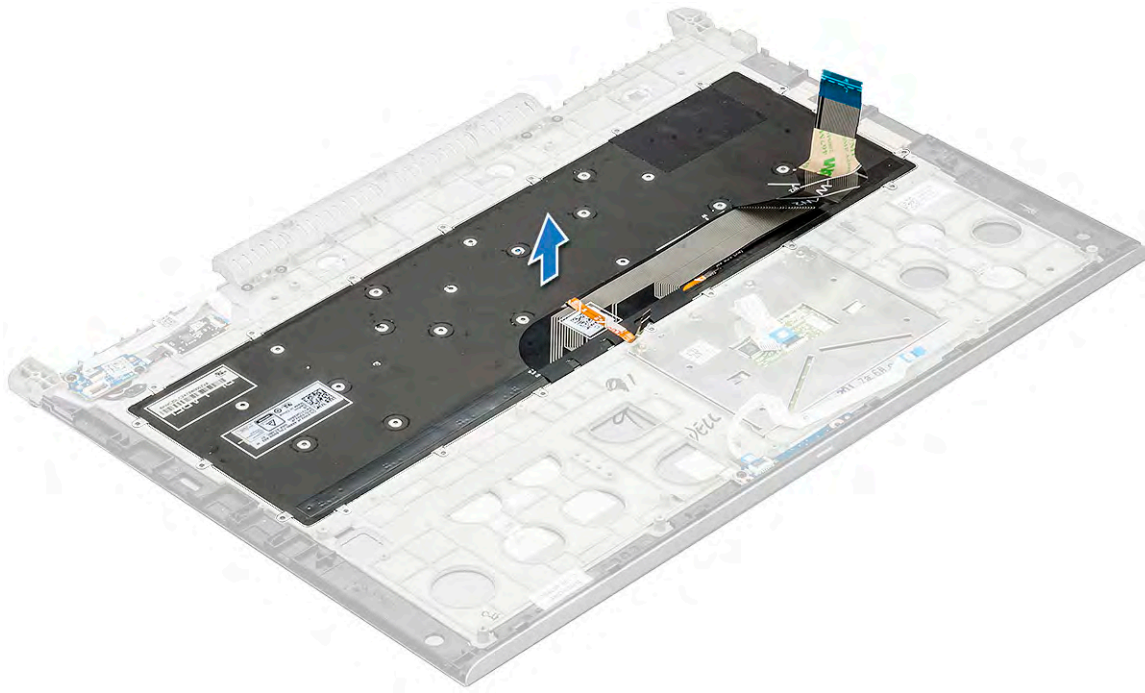

## Installing the keyboard

- 1 Place the keyboard into the slot on the palm rest.
- 2 Place the keyboard bracket above the keyboard.
- 3 Replace the thirty (M1.6x2) screws that secure the keyboard bracket to the palm rest.
- 4 Connect the following cables:
  - a power board cable
  - b LED board cable
  - c keyboard backlight cable
  - d touchpad cable
  - e keyboard cable
- 5 Install the:
  - a [display hinge](#)
  - b [back cover](#)
  - c [rear cover](#)
  - d [memory module](#)
  - e [WLAN card](#)
  - f [HDD](#)
  - g [SSD card](#)
  - h [battery](#)
  - i [base cover](#)
- 6 Follow the procedure in [After working inside your computer](#).

# Display assembly

## Removing the display assembly

- 1 Follow the procedure in [Before working inside your computer](#).
- 2 Remove the:
  - a [base cover](#)
  - b [battery](#)
  - c [SSD card](#)
  - d [WLAN card](#)
  - e [HDD](#)
  - f [memory module](#)
  - g [rear cover](#)
  - h [back cover](#)
- 3 To remove hinge bracket:
  - a Remove the two (M2.5x5) screws that secure the hinge bracket to the display assembly [1].
  - b Lift the hinge bracket from the display assembly [2].

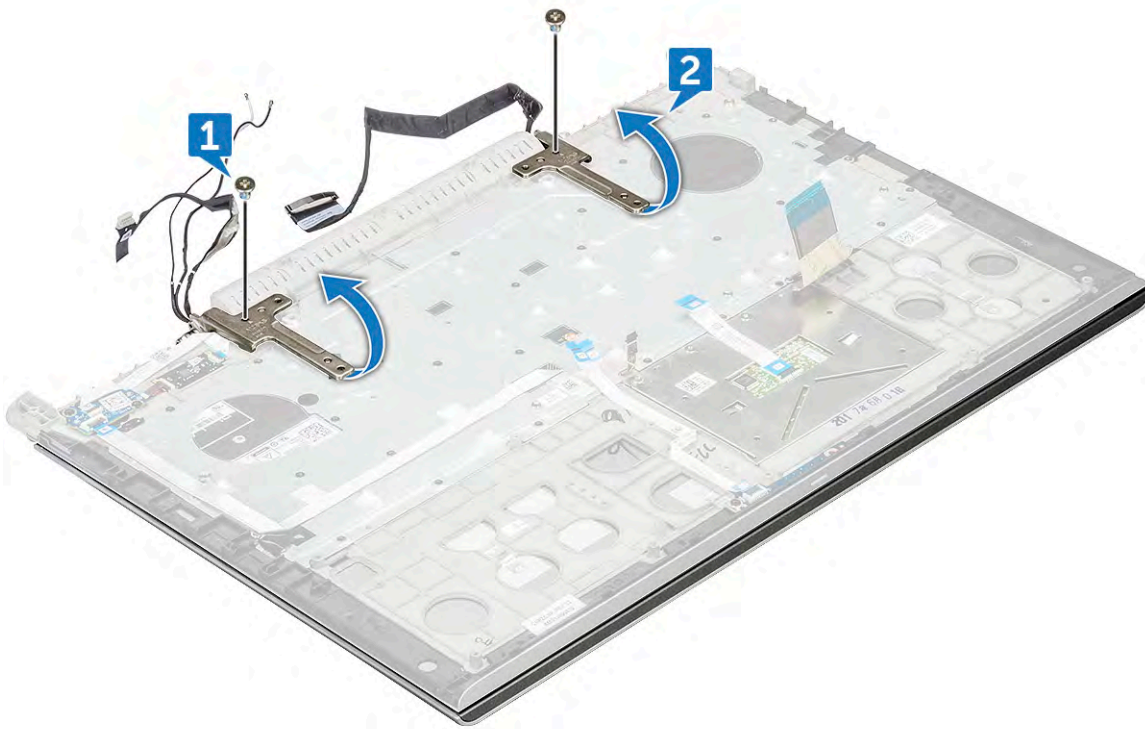

- 4 Slide and lift the display assembly.

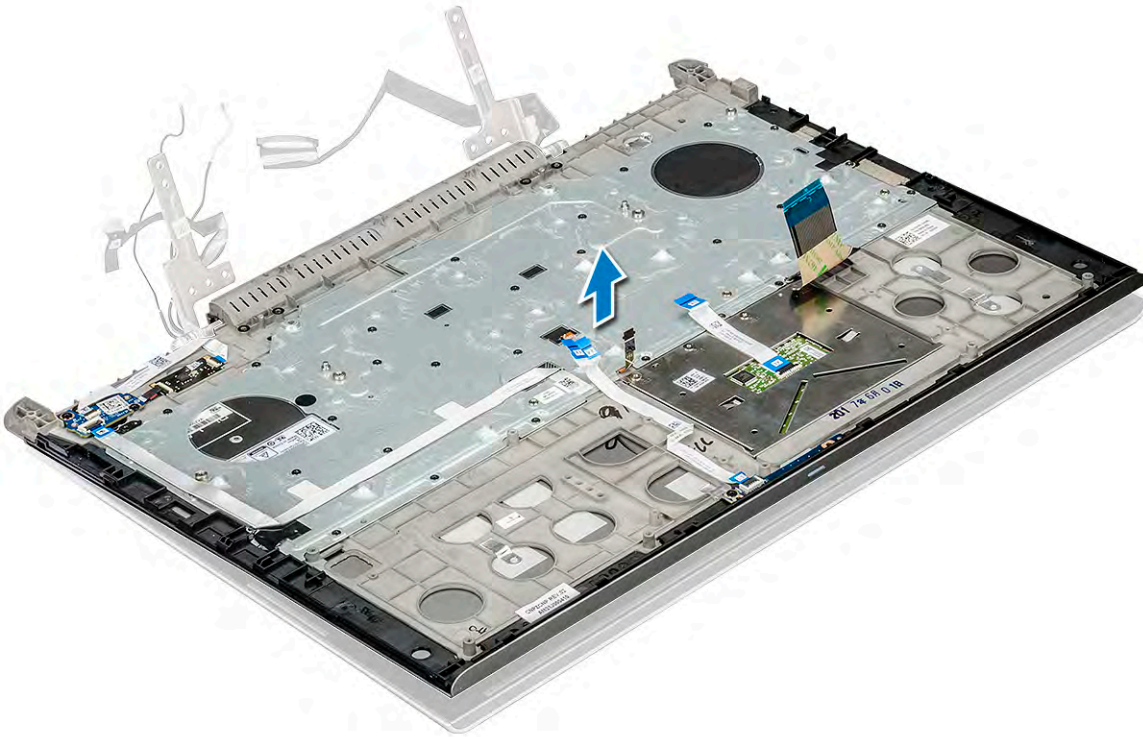

5 The component you are left with is the display assembly.



## Installing the display assembly

- 1 Place the display assembly on the system.
- 2 Place the hinge bracket on the display assembly.

- 3 Replace the M2.5x5L(2) screws to secure the hinge bracket to the display assembly.
- 4 Install the:
  - a back cover
  - b rear cover
  - c memory module
  - d WLAN card
  - e HDD
  - f SSD card
  - g battery
  - h base cover
- 5 Follow the procedure in [After working inside your computer](#).

## Palm rest

### Removing the palm rest assembly

- 1 Follow the procedure in [Before working inside your computer](#).
- 2 Remove the:
  - a base cover
  - b battery
  - c coin cell battery
  - d SSD card
  - e memory module
  - f hard drive
  - g WLAN card
  - h rear cover
  - i back cover
  - j touchpad
  - k LED board
  - l power button board
  - m fingerprint reader
  - n keyboard
  - o display assembly
  - p display hinge

 **NOTE:** After the removal of all the components the component that you are left with is the palm rest



- 3 Install the following components on the new palm rest.
  - a display hinge
  - b display assembly
  - c keyboard
  - d fingerprint reader
  - e power button board
  - f LED board
  - g touchpad
  - h back cover
  - i rear cover
  - j WLAN card
  - k hard drive
  - l memory module
  - m SSD card
  - n coin cell battery
  - o battery
  - p base cover
- 4 Follow the procedure in [After working inside your computer](#)

## Display bezel

### Removing the display bezel

- 1 Follow the procedure in [Before working inside your computer](#).
- 2 Remove the:
  - a base cover
  - b battery
  - c SSD card
  - d WLAN card
  - e HDD
  - f memory module

- g rear cover
- h back cover
- i display assembly

3 Using a plastic scribe, pry the inner bottom and inner side edges to release the display bezel from the display assembly [1, 2].

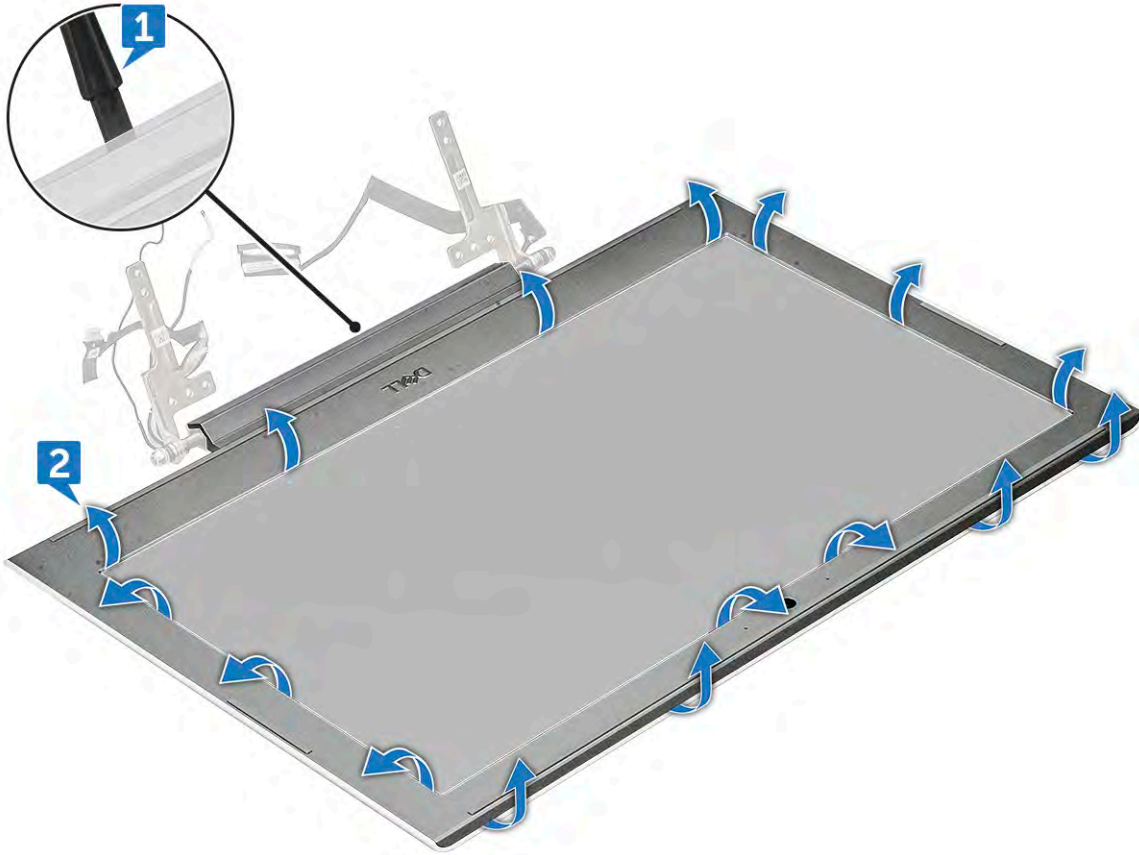

4 Remove the display bezel from display assembly.



## Installing the display bezel

- 1 Place the display bezel on the display assembly.
- 2 Starting from the top corner, press on the display bezel and work around the entire bezel until it clicks on to the display assembly.
- 3 Install the:
  - a display assembly
  - b back cover
  - c rear cover
  - d memory module
  - e WLAN card
  - f HDD
  - g SSD card
  - h battery
  - i base cover
- 4 Follow the procedure in [After working inside your computer](#).

## Camera

### Removing the camera

- 1 Follow the procedure in [Before working inside your computer](#).
- 2 Remove the:
  - a base cover
  - b battery
  - c SSD card
  - d WLAN card

- e HDD
- f memory module
- g rear cover
- h back cover
- i display assembly
- j display bezel

- 3 To remove the camera:
  - a Peel and slide the camera from the display [1].
  - b Disconnect the camera cable from the connector [2].
  - c Lift the camera away from the system [3].

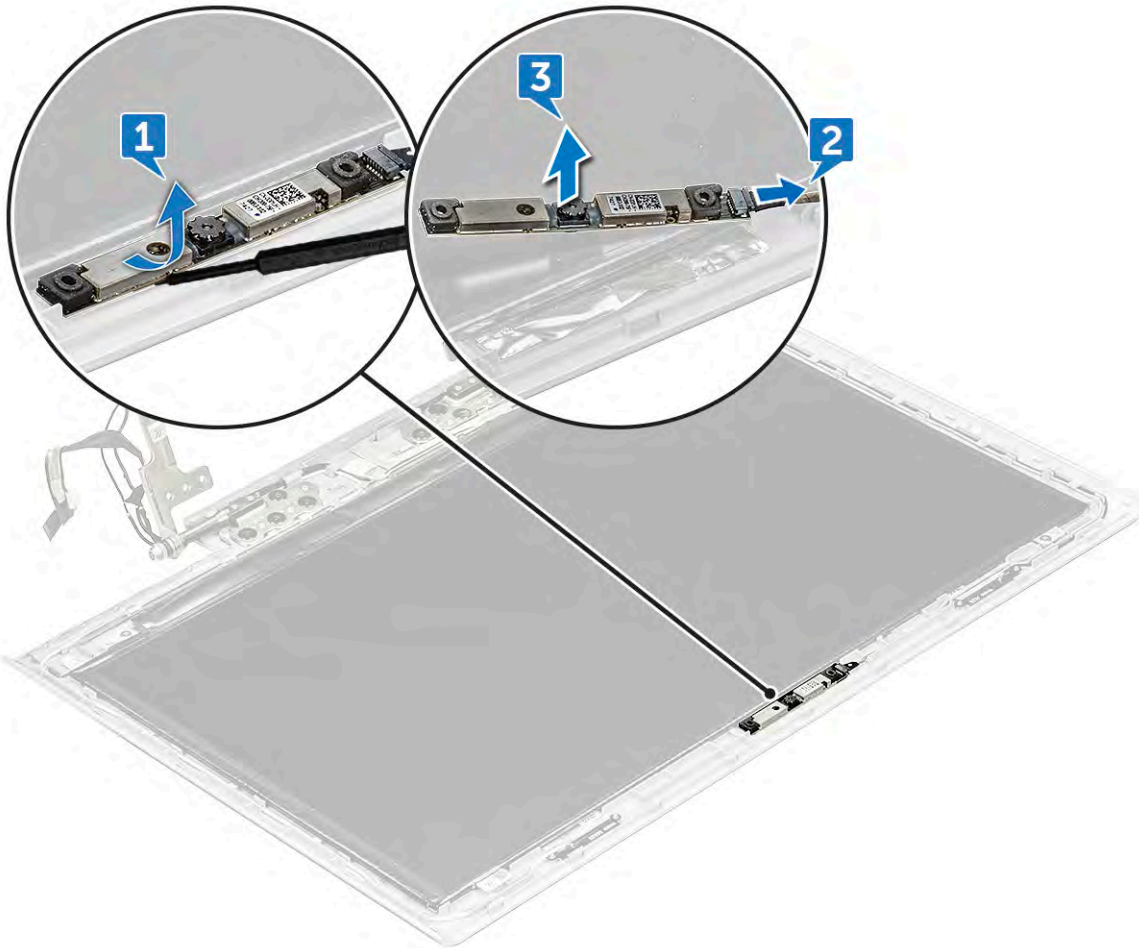

## Installing the camera

- 1 Place and affix the camera on the slot in the display assembly.
- 2 Connect the camera cable to the connector on the display assembly.
- 3 Install the:
  - a display bezel
  - b display assembly
  - c back cover
  - d rear cover
  - e memory module
  - f WLAN card
  - g HDD



- h SSD card
- i battery
- j base cover

4 Follow the procedure in [After working inside your computer](#).

## Display hinges

### Removing the display hinge

1 Follow the procedure in [Before working inside your computer](#).

2 Remove the:

- a base cover
- b battery
- c SSD card
- d WLAN card
- e HDD
- f memory module
- g rear cover
- h back cover
- i display assembly
- j display bezel

3 To remove the display hinge:

- a Remove the eight (M2.5x2.5) screws that secure the display hinge to the display assembly [1].
- b Lift the display hinge away from the display assembly [2].

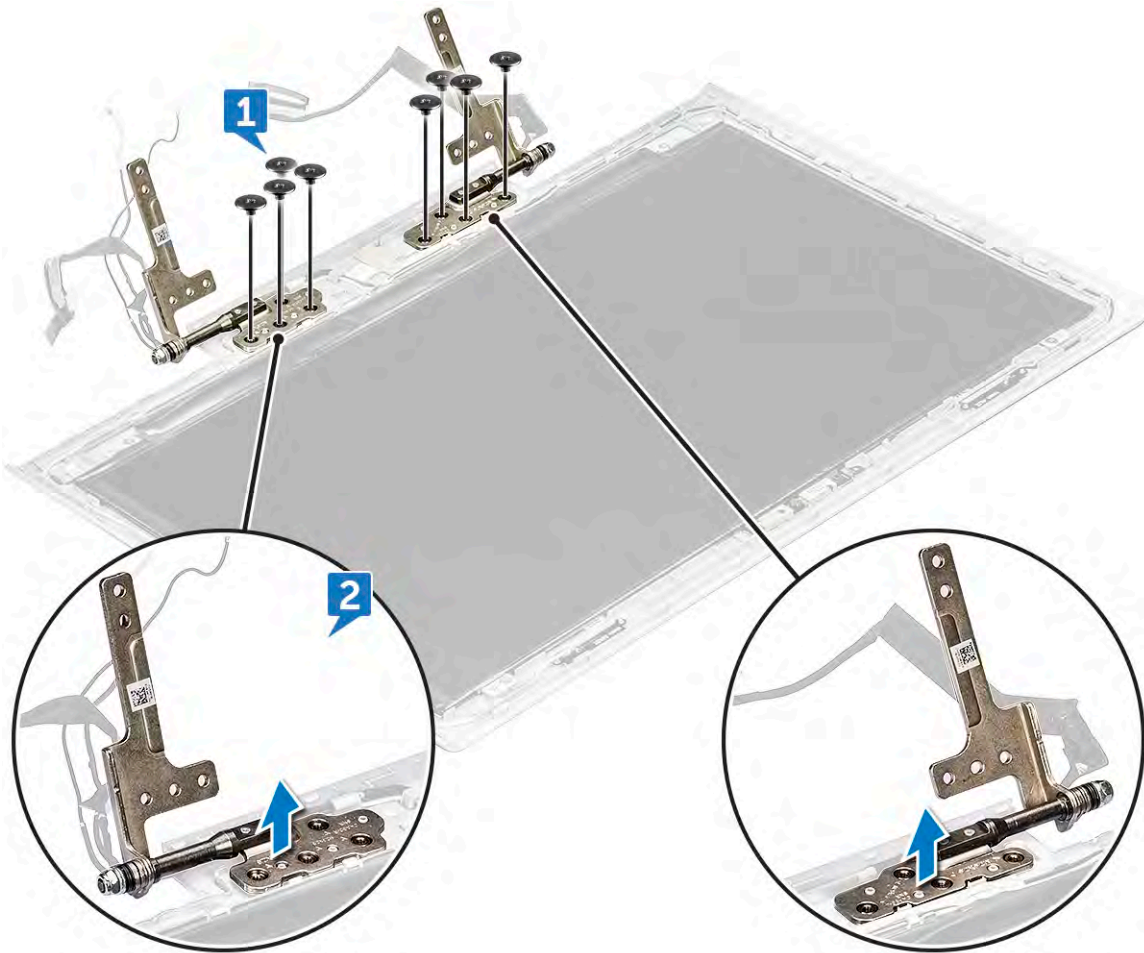

# Installing the display hinge

- 1 Place the display hinge on the display assembly.
- 2 Replace the eight (M2.5x2.5) screws to secure the display hinges to the display assembly.
- 3 Install the:
  - a display bezel
  - b display assembly
  - c back cover
  - d rear cover
  - e memory module
  - f WLAN card
  - g HDD
  - h SSD card
  - i battery
  - j base cover
- 4 Follow the procedure in [After working inside your computer](#).

# Display panel

## Removing the display panel — Non touch

- 1 Follow the procedure in [Before working inside your computer](#).
- 2 Remove the:
  - a base cover
  - b battery
  - c SSD card
  - d WLAN card
  - e HDD
  - f memory module
  - g rear cover
  - h back cover
  - i display assembly
  - j display bezel
  - k display hinge
- 3 Remove the four (M2x2.5) screws that secure the display panel to the display assembly [1] and lift to turn over the display panel to access the display (eDP) cable [2].





4 To remove display panel:

- a Remove the adhesive tape that covers the display (eDP) cable connector [1].
- b Lift the latch and disconnect the display (eDP) cable from the connector on the display panel [2].
- c Lift the display panel [3].

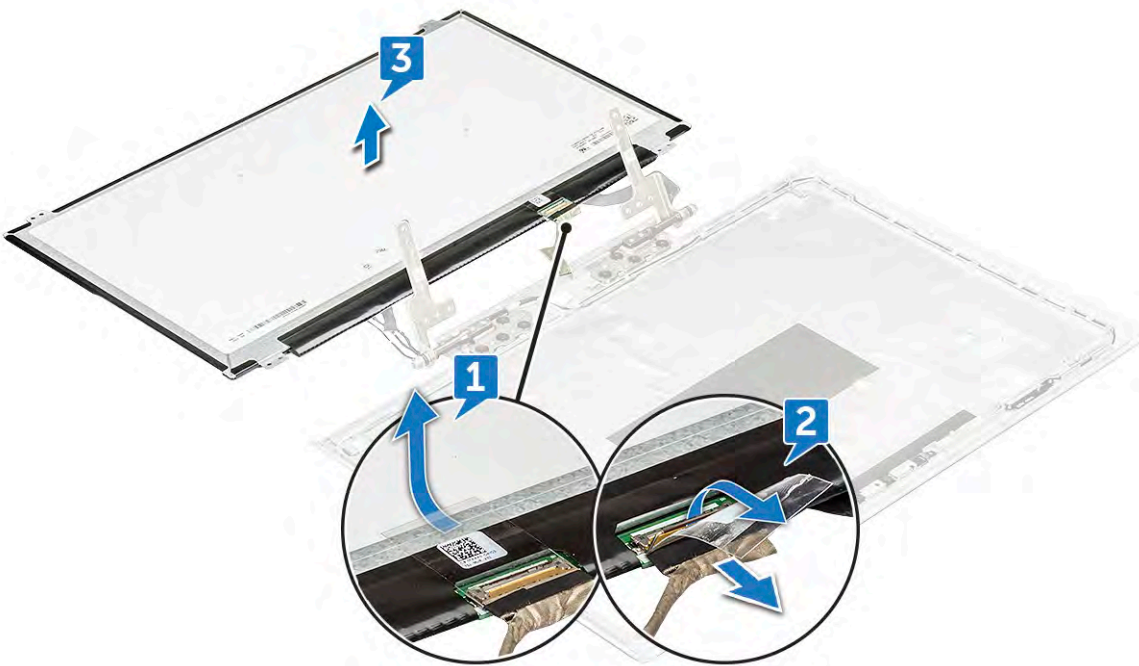

# Installing the display panel

- 1 Connect the display (eDP) cable to the connector in the display panel.
- 2 Affix the adhesive tape to secure the display (eDP) cable.
- 3 Place the display panel to align with the screw holders on the display assembly.
- 4 Replace the four (M2x2.5) screws to secure the display panel to the display assembly.
- 5 Install the:
  - a [display bezel](#)
  - b [display assembly](#)
  - c [back cover](#)
  - d [rear cover](#)
  - e [memory module](#)
  - f [WLAN card](#)
  - g [HDD](#)
  - h [SSD card](#)
  - i [battery](#)
  - j [base cover](#)
- 6 Follow the procedure in [After working inside your computer](#).

## eDP cable

## Removing the eDP cable

- 1 Follow the procedure in [Before working inside your computer](#).
- 2 Remove the:
  - a [base cover](#)
  - b [battery](#)
  - c [SSD card](#)
  - d [WLAN card](#)
  - e [HDD](#)
  - f [memory module](#)
  - g [rear cover](#)
  - h [back cover](#)
  - i [display assembly](#)
  - j [display bezel](#)
  - k [display hinge](#)
  - l [display panel](#)
- 3 Unroute the eDP cable from the routing channel to remove from the display.



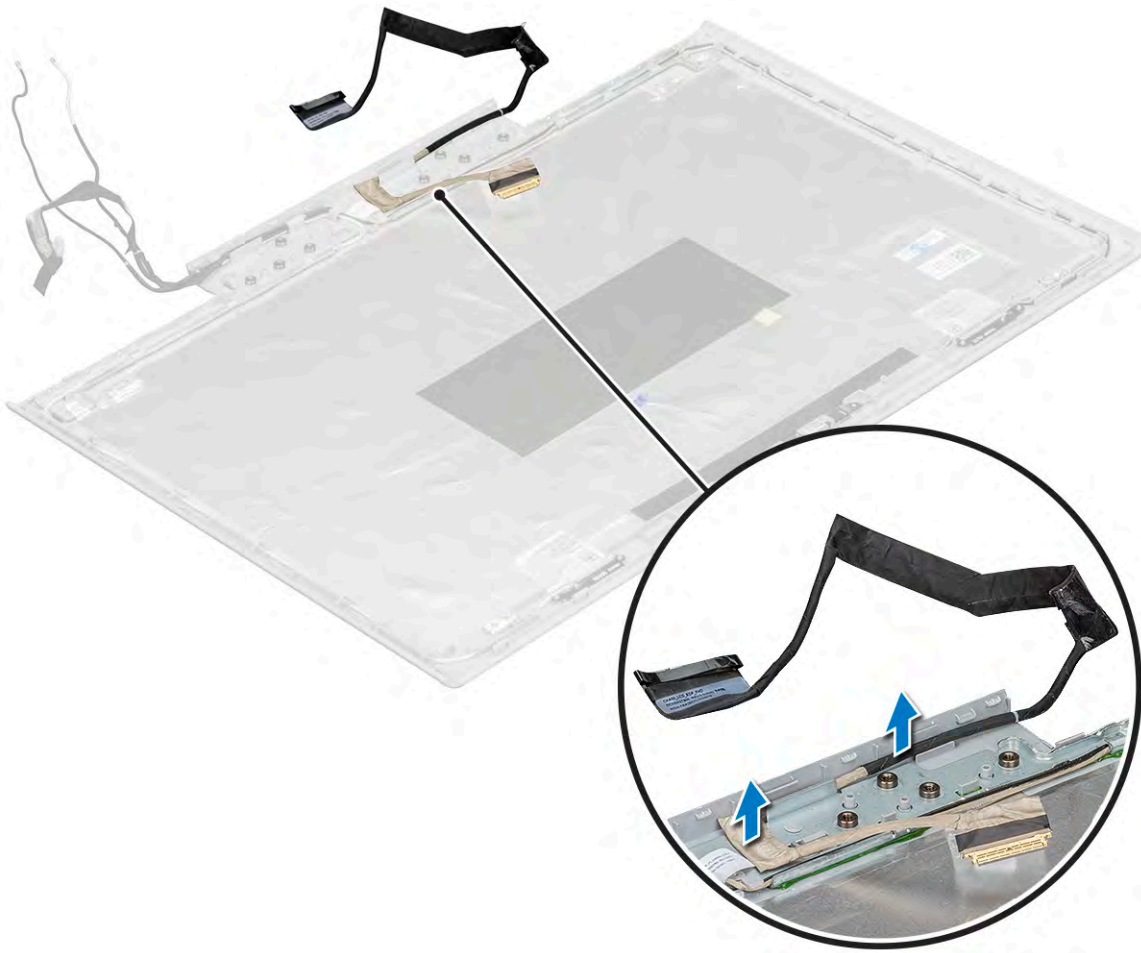

## Installing the eDP cable

- 1 Place the eDP cable on the display panel.
- 2 Route the eDP cable through the routing channel.
- 3 Install the:
  - a display hinge
  - b display panel
  - c display bezel
  - d display assembly
  - e back cover
  - f rear cover
  - g memory module
  - h WLAN card
  - i HDD
  - j SSD card
  - k battery
  - l base cover
- 4 Follow the procedure in [After working inside your computer](#).

# Display back cover assembly

## Removing the display back cover assembly

- 1 Follow the procedure in [Before working inside your computer](#).
- 2 Remove the:
  - a base cover
  - b battery
  - c SSD card
  - d WLAN card
  - e HDD
  - f memory module
  - g rear cover
  - h back cover
  - i display assembly
  - j display bezel
  - k display hinge
  - l display panel
  - m camera
  - n eDP cable
- 3 The display back cover assembly is the remaining component, after removing all the components.

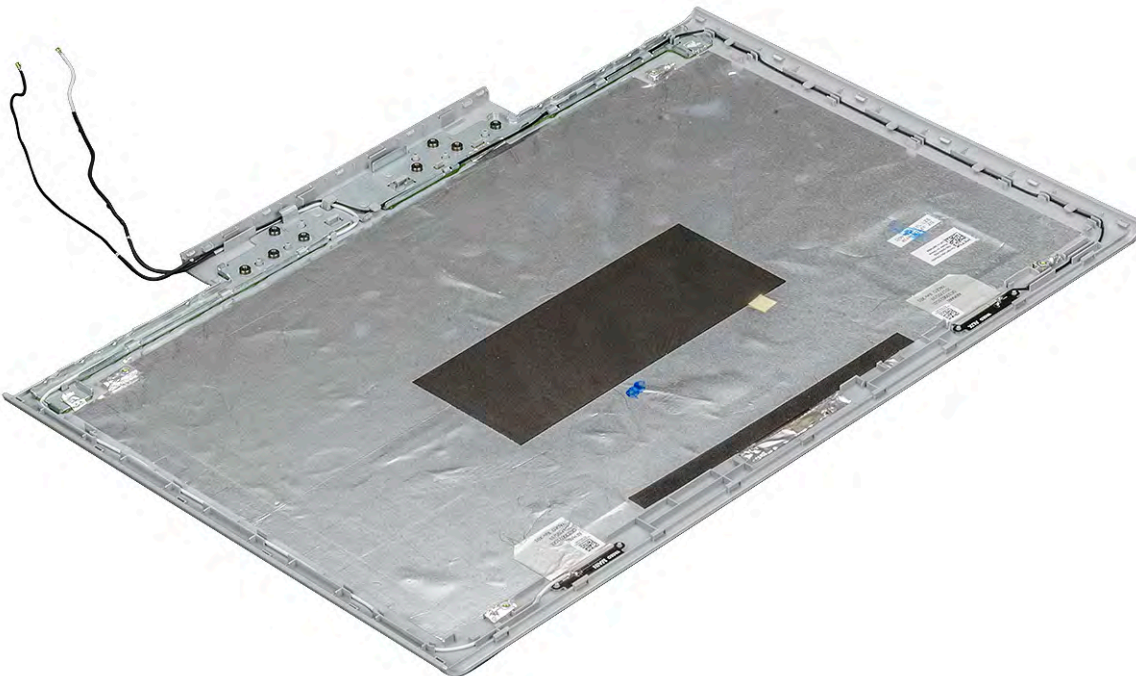

## Installing the display back cover assembly

- 1 The display back cover assembly is the remaining component, after removing all the components.
- 2 Install the:
  - a eDP cable
  - b camera
  - c display panel



- d display bezel
- e display assembly
- f back cover
- g rear cover
- h memory module
- i WLAN card
- j HDD
- k SSD card
- l battery
- m base cover

3 Follow the procedure in [After working inside your computer](#).



# Technology and components

This chapter details the technology and components available in the system.

Topics:

- [AC Adapters](#)
- [DDR4](#)
- [USB features](#)
- [USB Type-C](#)
- [NVIDIA GeForce GTX 1050 Graphics](#)
- [NVIDIA GeForce GTX 1050Ti Graphics](#)
- [NVIDIA GeForce GTX 1060 Graphics](#)

## AC Adapters



This laptop is shipped with following AC adapter:

- 130 W 3-Pin
- 180 W 3-Pin
- When you disconnect the AC adapter cable from the computer, grasp the connector, not the cable itself, and then pull firmly but gently to avoid damaging the cable.
- The AC adapter works with electrical outlets worldwide. However, power connectors and power strips vary among countries. Using an incompatible cable or improperly connecting the cable to the power strip or electrical outlet may cause fire or equipment damage.

## How to check the status of AC Adapter in BIOS?

- 1 Restart / Power on your computer.
- 2 At the first text on the screen or when the Dell logo appears, tap <F2> until the message **Entering Setup** appears.
- 3 Under **General** > **Battery Information**, you will see **AC Adapter** listed.

## DDR4

DDR4 (double data rate fourth generation) memory is a higher-speed successor to the DDR2 and DDR3 technologies and allows up to 512 GB in capacity, compared to the DDR3's maximum of 128 GB per DIMM. DDR4 synchronous dynamic random-access memory is keyed differently from both SDRAM and DDR to prevent the user from installing the wrong type of memory into the system.

DDR4 needs 20 percent less or just 1.2 volts, compared to DDR3 which requires 1.5 volts of electrical power to operate. DDR4 also supports a new, deep power-down mode that allows the host device to go into standby without needing to refresh its memory. Deep power-down mode is expected to reduce standby power consumption by 40 to 50 percent.



# DDR4 Details

There are subtle differences between DDR3 and DDR4 memory modules, as listed below.

## Key notch difference

The key notch on a DDR4 module is in a different location from the key notch on a DDR3 module. Both notches are on the insertion edge but the notch location on the DDR4 is slightly different, to prevent the module from being installed into an incompatible board or platform.

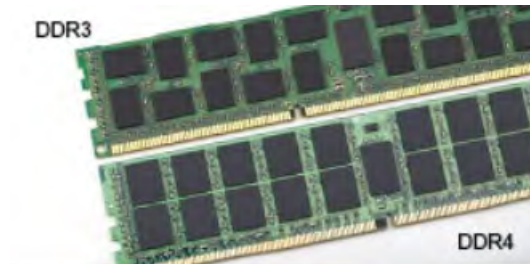

**Figure 1. Notch difference**

## Increased thickness

DDR4 modules are slightly thicker than DDR3, to accommodate more signal layers.



**Figure 2. Thickness difference**

## Curved edge

DDR4 modules feature a curved edge to help with insertion and alleviate stress on the PCB during memory installation.



**Figure 3. Curved edge**

# Memory Errors

Memory errors on the system display the new ON-FLASH-FLASH or ON-FLASH-ON failure code. If all memory fails, the LCD does not turn on. Troubleshoot for possible memory failure by trying known good memory modules in the memory connectors on the bottom of the system or under the keyboard, as in some portable systems.

# USB features

Universal Serial Bus, or USB, was introduced in 1996. It dramatically simplified the connection between host computers and peripheral devices like mice, keyboards, external drives, and printers.

Let's take a quick look on the USB evolution referencing to the table below.

**Table 1. USB evolution**

| Type                  | Data Transfer Rate | Category    | Introduction Year |
|-----------------------|--------------------|-------------|-------------------|
| USB 3.0/USB 3.1 Gen 1 | 5 Gbps             | Super Speed | 2010              |
| USB 2.0               | 480 Mbps           | High Speed  | 2000              |

## USB 3.0/USB 3.1 Gen 1 (SuperSpeed USB)

For years, the USB 2.0 has been firmly entrenched as the de facto interface standard in the PC world with about 6 billion devices sold, and yet the need for more speed grows by ever faster computing hardware and ever greater bandwidth demands. The USB 3.0/USB 3.1 Gen 1 finally has the answer to the consumers' demands with a theoretically 10 times faster than its predecessor. In a nutshell, USB 3.1 Gen 1 features are as follows:

- Higher transfer rates (up to 5 Gbps)
- Increased maximum bus power and increased device current draw to better accommodate power-hungry devices
- New power management features
- Full-duplex data transfers and support for new transfer types
- Backward USB 2.0 compatibility
- New connectors and cable

The topics below cover some of the most commonly asked questions regarding USB 3.0/USB 3.1 Gen 1.



## Speed

Currently, there are 3 speed modes defined by the latest USB 3.0/USB 3.1 Gen 1 specification. They are Super-Speed, Hi-Speed and Full-Speed. The new SuperSpeed mode has a transfer rate of 4.8Gbps. While the specification retains Hi-Speed, and Full-Speed USB mode, commonly known as USB 2.0 and 1.1 respectively, the slower modes still operate at 480Mbps and 12Mbps respectively and are kept to maintain backward compatibility.

USB 3.0/USB 3.1 Gen 1 achieves the much higher performance by the technical changes below:

- An additional physical bus that is added in parallel with the existing USB 2.0 bus (refer to the picture below).
- USB 2.0 previously had four wires (power, ground, and a pair for differential data); USB 3.0/USB 3.1 Gen 1 adds four more for two pairs of differential signals (receive and transmit) for a combined total of eight connections in the connectors and cabling.
- USB 3.0/USB 3.1 Gen 1 utilizes the bidirectional data interface, rather than USB 2.0's half-duplex arrangement. This gives a 10-fold increase in theoretical bandwidth.

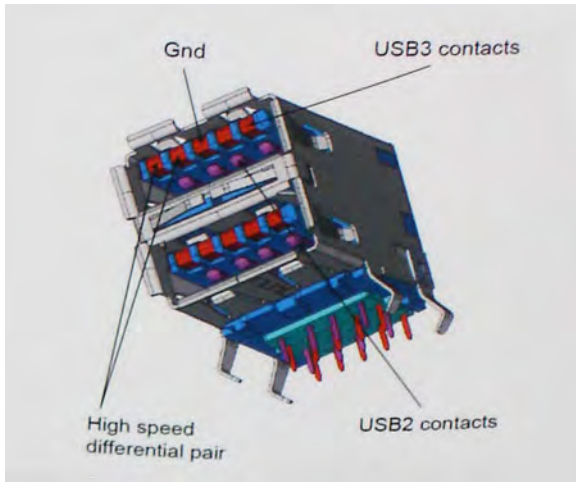

With today's ever increasing demands placed on data transfers with high-definition video content, terabyte storage devices, high megapixel count digital cameras etc., USB 2.0 may not be fast enough. Furthermore, no USB 2.0 connection could ever come close to the 480Mbps theoretical maximum throughput, making data transfer at around 320Mbps (40MB/s) — the actual real-world maximum. Similarly, USB 3.0/USB 3.1 Gen 1 connections will never achieve 4.8Gbps. We will likely see a real-world maximum rate of 400MB/s with overheads. At this speed, USB 3.0/USB 3.1 Gen 1 is a 10x improvement over USB 2.0.

## Applications

USB 3.0/USB 3.1 Gen 1 opens up the laneways and provides more headroom for devices to deliver a better overall experience. Where USB video was barely tolerable previously (both from a maximum resolution, latency, and video compression perspective), it's easy to imagine that with 5-10 times the bandwidth available, USB video solutions should work that much better. Single-link DVI requires almost 2Gbps throughput. Where 480Mbps was limiting, 5Gbps is more than promising. With its promised 4.8Gbps speed, the standard will find its way into some products that previously weren't USB territory, like external RAID storage systems.

Listed below are some of the available SuperSpeed USB 3.0/USB 3.1 Gen 1 products:

- External Desktop USB 3.0/USB 3.1 Gen 1 Hard Drives
- Portable USB 3.0/USB 3.1 Gen 1 Hard Drives
- USB 3.0/USB 3.1 Gen 1 Drive Docks & Adapters
- USB 3.0/USB 3.1 Gen 1 Flash Drives & Readers
- USB 3.0/USB 3.1 Gen 1 Solid-state Drives
- USB 3.0/USB 3.1 Gen 1 RAID's
- Optical Media Drives
- Multimedia Devices
- Networking
- USB 3.0/USB 3.1 Gen 1 Adapter Cards & Hubs

## Compatibility

The good news is that USB 3.0/USB 3.1 Gen 1 has been carefully planned from the start to peacefully co-exist with USB 2.0. First of all, while USB 3.0/USB 3.1 Gen 1 specifies new physical connections and thus new cables to take advantage of the higher speed capability of the new protocol, the connector itself remains the same rectangular shape with the four USB 2.0 contacts in the exact same location as before. Five new connections to carry receive and transmitted data independently are present on USB 3.0/USB 3.1 Gen 1 cables and only come into contact when connected to a proper SuperSpeed USB connection.

Windows 8/10 will be bringing native support for USB 3.1 Gen 1 controllers. This is in contrast to previous versions of Windows, which continue to require separate drivers for USB 3.0/USB 3.1 Gen 1 controllers.

Microsoft announced that Windows 7 would have USB 3.1 Gen 1 support, perhaps not on its immediate release, but in a subsequent Service Pack or update. It is not out of the question to think that following a successful release of USB 3.0/USB 3.1 Gen 1 support in Windows 7, SuperSpeed support would trickle down to Vista. Microsoft has confirmed this by stating that most of their partners share the opinion that Vista should also support USB 3.0/USB 3.1 Gen 1.

## USB Type-C

USB Type-C is a new, tiny physical connector. The connector itself can support various exciting new USB standard like USB 3.1 and USB power delivery (USB PD).

### Alternate Mode

USB Type-C is a new connector standard that's very small. It's about a third the size of an old USB Type-A plug. This is a single connector standard that every device should be able to use. USB Type-C ports can support a variety of different protocols using "alternate modes," which allows you to have adapters that can output HDMI, VGA, DisplayPort, or other types of connections from that single USB port

### USB Power Delivery

The USB PD specification is also closely intertwined with USB Type-C. Currently, smartphones, tablets, and other mobile devices often use a USB connection to charge. A USB 2.0 connection provides up to 2.5 watts of power — that'll charge your phone, but that's about it. A laptop might require up to 60 watts, for example. The USB Power Delivery specification ups this power delivery to 100 watts. It's bi-directional, so a device can either send or receive power. And this power can be transferred at the same time the device is transmitting data across the connection.

This could spell the end of all those proprietary laptop charging cables, with everything charging via a standard USB connection. You could charge your laptop from one of those portable battery packs you charge your smartphones and other portable devices from today. You could plug your laptop into an external display connected to a power cable, and that external display would charge your laptop as you used it as an external display — all via the one little USB Type-C connection. To use this, the device and the cable have to support USB Power Delivery. Just having a USB Type-C connection doesn't necessarily mean they do.

### USB Type-C and USB 3.1

USB 3.1 is a new USB standard. USB 3's theoretical bandwidth is 5 Gbps, while USB 3.1 Gen2 is 10Gbps. That's double the bandwidth, as fast as a first-generation Thunderbolt connector. USB Type-C isn't the same thing as USB 3.1. USB Type-C is just a connector shape, and the underlying technology could just be USB 2 or USB 3.0. In fact, Nokia's N1 Android tablet uses a USB Type-C connector, but underneath it's all USB 2.0 — not even USB 3.0. However, these technologies are closely related.

## NVIDIA GeForce GTX 1050 Graphics

The Nvidia GTX 1050 is a mainstream GPU based on the Pascal architecture and was announced in January 2017. Contrary to the faster models, the GTX 1050 uses the GP107 chip.

### Features

The GP107 chip is manufactured in a 14 nm FinFET process at Samsung and offers a number of new features, including support for DisplayPort 1.4 (ready), HDMI 2.0b, HDR, Simultaneous Multi-Projection (SMP) as well as improved H.265 video de- and encoding (PlayReady 3.0).



## Power Consumption

The NVIDIA GeForce GTX 1050 Graphics can be found in several notebook and desktop processors of different TDP classes (40 — 50 W).

## Key Specifications

The following table contains the key specifications of the NVIDIA GeForce GTX 1050:

**Table 2. Key Specifications**

| Specification      | NVIDIA GeForce GTX 1050                         |
|--------------------|---|
| HD Graphics Series | NVIDIA GeForce GTX 1050                         |
| Codename           | N17P-G0   |
| Architecture       | Pascal  |
| Pipelines          | 640 - unified                                   |
| Core Speed *       | 1354 - 1493 (Boost) MHz                         |
| Memory Bus Width   | 7000 MHz  |
| Shared Memory      | No  |
| Technology         | 14 nm   |
| Features           | Multi-Projection, G-SYNC, Vulkan, Multi Monitor |
| DirectX            | DirectX 12_1                                    |

## NVIDIA GeForce GTX 1050Ti Graphics

The Nvidia GTX 1050 Ti is a mainstream GPU based on the Pascal architecture and was announced in January 2017. Contrary to the faster models, the GTX 1050 Ti uses the GP107 chip.

## Features

The GP107 chip is manufactured in a 14 nm FinFET process at Samsung and offers a number of new features, including support for DisplayPort 1.4 (ready), HDMI 2.0b, HDR, Simultaneous Multi-Projection (SMP) as well as improved H.265 video de- and encoding (PlayReady 3.0).

## Power Consumption

The NVIDIA GeForce GTX 1050 Ti Graphics can be found in several notebook and desktop processors of different TDP classes (70 W).

## Key Specifications

The following table contains the key specifications of the NVIDIA GeForce GTX 1050 Ti:

**Table 3. Key Specifications**

| Specification      | NVIDIA GeForce GTX 1050 Ti                      |
|--------------------|---|
| HD Graphics Series | NVIDIA GeForce GTX 1050 Ti                      |
| Codename           | N17P-G1   |
| Architecture       | Pascal  |
| Pipelines          | 768 - unified                                   |
| Core Speed *       | 1493 - 1620 (Boost) MHz                         |
| Memory Bus Width   | 7000 MHz  |
| Shared Memory      | No  |
| Technology         | 14 nm   |
| Features           | Multi-Projection, G-SYNC, Vulkan, Multi Monitor |
| DirectX            | DirectX 12_1                                    |

## NVIDIA GeForce GTX 1060 Graphics

The mobile Nvidia GeForce GTX 1060 is a graphics card for high end laptops. It is based on the Pascal architecture and manufactured in 16 nm FinFET at TSMC. The GPU is using the smaller GP106 chip. Compared to the desktop version of the GTX 1060, the laptop version offers the same amount of shader but slightly lower clock rates.

### Features

The GP106 chip is produced in 16nm FinFET at TSMC and offers a range of new features, like DisplayPort 1.4 (ready), HDMI 2.0b, HDR, Simultaneous Multi-Projection (SMP) and improved H.265 video de- and encoding (PlayReady 3.0).

### Power Consumption

NVIDIA GeForce GTX 1060 Graphics can be found in several notebook and desktop processors of different TDP classes (80 W).

### Key Specifications

The following table contains the key specifications of the NVIDIA GeForce GTX 1060:

**Table 4. Key Specifications**

| Specification      | NVIDIA GeForce GTX 1060 |
|--------------------|-------------------------|
| HD Graphics Series | NVIDIA GeForce GTX 1060 |
| Codename           | N17E-G1                 |
| Architecture       | Pascal                  |
| Pipelines          | 1280 - unified          |
| Core Speed *       | 1506 - 1708 (Boost) MHz |
| Memory Bus Width   | 8000 MHz                |



**Specification****NVIDIA GeForce GTX 1060**

---

|               |   |
|---------------|---|
| Shared Memory | No  |
| Technology    | 16 nm   |
| Features      | Multi-Projection, G-SYNC, Vulkan, Multi Monitor |
| DirectX       | DirectX 12_1                                    |



# System specifications

Topics:

- Processor
- Memory
- Video
- Audio
- Connectivity options
- Ports and Connectors
- Display specifications
- Keyboard
- Touchpad
- Storage
- Battery specifications
- Adapter options
- Webcam specifications
- System dimensions Vostro 15-7580
- Environmental

## Processor

Dell Vostro system is built with Intel Core i processors.

**Table 5. CPU**

| Processors Support List             | Graphics                  |
|-------------------------------------|---------------------------|
| Intel Core i5-8300H (up to 4.1 Ghz) | Intel(R) UHD Graphics 630 |
| Intel Core i7-8750H (up to 4.0 Ghz) | Intel(R) UHD Graphics 630 |

## Memory

Your computer supports a maximum of 32 GB of memory of memory when you use two 8 GB DIMMs; Moreover, certain components within the computer require address space in the 4 GB range. Any address space reserved for these components cannot be used by computer memory; therefore, the amount of memory available to a 32-bit operating system is less than 4GB. Greater than 4GB memory requires a 64-bit operating system.

**Table 6. Memory specifications**

| Memory                       | Feature       |
|------------------------------|---------------|
| Type                         | DDR4 2666 MHz |
| SoDIMM Slots                 | 2             |
| Minimum Memory Configuration | 4 GB          |



|                              |  |
|------------------------------|--|
| Maximum Memory Configuration | 32 GB  |
| DIMM Configurations          | 4 GB (1x4 GB)<br>8 GB (2x4 GB)<br>8 GB (1x8 GB)<br>12 GB (4 GB + 8 GB)<br>16 GB (2x8 GB)<br>16 GB (1x16 GB)<br>32 GB (2x16 GB) |

## Video

**Table 7. Video**

| Feature                      | Specification   |
|------------------------------|---|
| Type                         | MXM type-A add-in card  |
| Data bus                     | PCIe x16, Gen3  |
| Video controller and memory: | <ul style="list-style-type: none"> <li>• Intel(R) UHD Graphics 630</li> <li>• NVIDIA GeForce GTX 1050 Graphics with 2GB/4GB GDDR5 vRAM</li> <li>• NVIDIA GeForce GTX 1050Ti Graphics with 4GB GDDR5 vRAM</li> <li>• NVIDIA GeForce GTX 1060 Graphics with 6GB GDDR5 vRAM</li> </ul> |
| External display support     | <ul style="list-style-type: none"> <li>• On system - eDP (internal display), HDMI 2.0</li> <li>• Type-C port with Thunderbolt 3 - VGA, DisplayPort 1.2</li> </ul>   |

## Audio

**Table 8. Audio**

| Features                   | Specification  |
|----------------------------|--|
| Type                       | Integrated High Quality Stereo Speakers                          |
| Stereo conversion          | 24-bit (analog-to-digital and digital-to-analog)                 |
| Internal Interface         | High-definition audio codec                                      |
| External Interface         | Microphone-in and stereo headphones/speakers universal connector |
| Speakers                   | Power / Peak Power: 2X2Wrms/2X2.5Wpeak                           |
| Internal speaker amplifier | 2 watt per channel   |
| Internal microphone        | Digital microphone dual microphone with camera                   |
| Volume controls            | Hot keys   |

# Connectivity options

**Table 9. Connectivity option**

|                 |   |      |
|-----------------|---|------|
|                 |   | 7580 |
| Network adapter | RJ45- Rivet Killer LAN - E2400                              | Yes  |
| WLAN            | Intel Wireless 1x1 802.11AC Wi-Fi + BT 4.2 LE Wireless Card | Yes  |
|                 | QCA 802.11ac (2x2) + Bluetooth 4.1                          | Yes  |
|                 | QCA 802.11ac (1x1) Wireless Adapter+ Bluetooth 4.1          | Yes  |

# Ports and Connectors

**Table 10. Ports and Connectors**

| Feature   | Specifications   |
|-----------|--|
| USB       | USB 3.1 Gen 1 (1w/PowerShare)<br>USB Type-C port with Thunderbolt3   |
| HDMI      | Version 2.0 + VGA  |
| Modem     | NA   |
| Audio     | Stereo conversion: 24-bit (analog-to-digital and digital-to-analog)<br>Integrated High Quality Stereo Speakers<br>Universal Headphone Jack<br>Internal Interface - high-definition audio codec<br>Integrated dual array microphone<br>External Interface - microphone-in and stereo headphones/speakers universal connector<br>Speakers:Power / Peak Power: 2X2Wrms/2X2.5Wpeak, Internal speaker amplifier: 2 watt per channel, Internal microphone: digital microphone dual microphone with camera) |
| Expansion | SD card reader 2-in-1  |
|           |  |
|           |  |

# Display specifications

This topics lists out the detailed display specifications.

**Table 11. Display specifications**

|                                |  |
|--------------------------------|--|
|                                | <b>15.6 inch FHD Anti-Glare LCD display with LED backlight</b> |
| Type                           | FHD Anti-Glare   |
| Luminance/Brightness (typical) | 220 nits   |



|                                 | <b>15.6 inch FHD Anti-Glare LCD display with LED backlight</b> |
|---------------------------------|--|
| Diagonal                        | 15.6 inch  |
| Native Resolution               | 1920 x 1080  |
| Megapixels (millions of pixels) | 2.07   |
| Pixels per Inch (PPI)           | 142  |
| Contrast Ratio (min)            | 400:1  |
| Refresh Rate                    | 60 Hz  |
| U/D/R/L View Angle (min)        | 80/80/80/80  |
| Pixel Pitch                     | 0.179 mm   |
| Power Consumption (max)         | 4.05 W   |

## Keyboard

**Table 12. Keyboard Specifications**

|                |                               |
|----------------|-------------------------------|
| Number of keys | 101 (US) 102 (UK) 105 (Japan) |
| Layout         | US/UK/Japan                   |
| Size           | Full sized                    |
| Key travel     | 1.4 mm                        |

## Touchpad

**Table 13. Touchpad**

|                                |  |
|--------------------------------|--|
| <b>X/Y position resolution</b> | <b>(1637, 3061)</b>  |
| Size                           | Sensor-active area:<br>X-axis 105 mm<br>Y-axis 80 mm   |
| X/Y position resolution        | <ul style="list-style-type: none"> <li>· X: 41.27+-4.13 counts/mm</li> <li>· Y: 38.75+-3.88 counts/mm</li> <li>· 1048/984 cpi</li> </ul> |
| Multi-Touch                    | Configurable single finger and multi-finger gestures   |

**Table 14. Supported gestures**

| <b>Supported Gestures</b> | <b>Windows 10</b> |
|---------------------------|-------------------|
| Cursor moving             | Supported         |
| Clicking/ tapping         | Supported         |
| Click and drag            | Supported         |

| Supported Gestures              | Windows 10 |
|---------------------------------|------------|
| 2-finger scroll                 | Supported  |
| 2-finger Pinch                  | Supported  |
| 3-finger (Invoke Cortana)       | Supported  |
| 3-finger (Multi-tasking)        | Supported  |
| 4-finger (Invoke Action Center) | Supported  |
| 4-finger (Switch Desktop)       | Supported  |

## Storage

Table 15. Storage

| Features        | Specifications                                       |
|-----------------|--|
| Primary storage | 2.5 inch 500 GB 7200 RPM HDD (7mm)                   |
|                 | 2.5 inch 1 TB 5400 RPM HDD (7mm)                     |
|                 | 128 GB M.2 2280 SATA SSD                             |
|                 | 256 GB M.2 2280 SATA SSD                             |
|                 | 256 GB M.2 2230 PCIe NVMe SSD                        |
|                 | 512 GB M.2 2230 PCIe NVMe SSD                        |
|                 | Intel Optane memory 16 GB/32 GB                      |
|                 | Dual-drive storage scenario (M.2 SSD + 2.5 inch HDD) |

## Battery specifications

This topics lists out the detailed battery specifications.

Table 16. Battery specification

|                            |  |
|----------------------------|--|
|                            | 56 Whr (4 Cell) Prismatic with ExpressCharge |
| Type                       | Li-polymer                                   |
| Dimension                  |  |
| Length                     | 233.06 mm (9.170 inch)                       |
| Width                      | 90.73 mm (3.572 inch)                        |
| Weight                     | 250.00 g                                     |
| Height                     | 5.9 mm (0.232 inch)                          |
| Voltage                    | 15.2 VDC                                     |
| Typical Amp-hour capacity  | 3.67 Whr                                     |
| Typical Watt-hour capacity | 56 Whr                                       |
| <b>Temperature:</b>        |  |



|                       |   |
|-----------------------|---|
| Operating             | <ul style="list-style-type: none"> <li>Charge: 0 °C to 50 °C (32 °F to 122 °F)</li> <li>Discharge: 0 °C to 70 °C (32 °F to 158 °F)</li> </ul> |
| Non-operating         | -20 °C to 65 °C (-4 °F to 149 °F)   |
| Charging time:        |   |
| Express Charge mode   | <ul style="list-style-type: none"> <li>0~15°C: 4 hours</li> <li>16~45°C: 2 hours</li> <li>46~60°C: 3 hours</li> </ul>                         |
| Standard mode         | <ul style="list-style-type: none"> <li>0~15°C: 4 hours</li> <li>16~60°C: 3 hours</li> </ul>   |
| ExpressCharge capable | Yes (non-LLC only)  |
| BATTMAN capable       | Yes   |

## Adapter options

This topic lists the adapter specifications.

**Table 17. AC Adapter**

| Wattage                       | 130 W               | 180 W                 |
|-------------------------------|---------------------|-----------------------|
| <b>Adapter Specifications</b> |                     |                       |
| Input voltage                 | 100 to 240 VAC      | 100 to 240 VAC        |
| Input current (max)           | 2.5 A               | 2.5 A                 |
| Input Frequency               | 50 Hz to 60 Hz      | 50 Hz to 60 Hz        |
| Output current                | 6.7 A (continuous)  | 9.23 A (continuous)   |
| Rated output voltage          | 19.5 VDC            | 19.5 VDC              |
| Weight (lbs)                  | 1.15                | 1.25                  |
| Weight (kg)                   | 0.52                | 0.57                  |
| Dimensions (HxWxD inches)     | 1.0x3.0x6.1         | 1.2 x 3.0 x 6.1       |
| Dimensions (HxWxD mm)         | 25.4x 76.2 x 154.94 | 30.48 x 76.2 x 154.94 |
| Temperature range:            | 0° to 40°C          | 0° to 40°C            |

## Webcam specifications

This topic lists out the detailed camera specifications.

Easy Remote Collaboration:

- Video conference online with an optional built-in camera.

**Table 18. Webcam specification**

| Webcam                   | Features                    |
|--------------------------|-----------------------------|
| Camera Type              | HD fixed focus Front-facing |
| Sensor Type              | CMOS sensor technology      |
| Resolution: Motion Video | Up to 1280 x 720 (0.92 MP)  |
| Resolution: Still Image  | Up to 1280 x 720 (0.92MP)   |
| Imaging Rate             | Up to 30 frames per second  |

## System dimensions Vostro 15-7580

This topic lists out the dimensions of the computer in detail.

**Table 19. System dimensions**

| System dimension         | Features  |
|--------------------------|---|
| Weight (pounds/kilogram) | Start from 6.24 lb/2.83 kg                                  |
| Dimensions inches:       |   |
| Height                   | Front – 23.95 mm (0.94 inch)<br>Back – 24.95 mm (0.98 inch) |
| Width                    | 389.0 mm (15.31 inch)                                       |
| Depth                    | 270.0 mm (10.62 inches)                                     |

**NOTE:** System weight and shipping weight is based on a typical configuration and may vary based on the actual configuration.

## Environmental

Feature Specification

**Temperature range:**

**Operating** 10° C to 35° C (50° F to 95° F)

**Storage** -40° C to 65° C (-40° F to 149° F)

**Relative humidity (maximum):**

**Storage** 20% to 80% (non-condensing)

**Maximum vibration:**

**Operating** 5 to 350 Hz at 0.0002 G<sup>2</sup>/Hz

**Storage** 5 to 500 Hz at 0.001 to 0.01 G<sup>2</sup>/Hz

**Maximum shock:**

**Operating** 40 G +/- 5% with pulse duration of 2 msec +/-10% (equivalent to 51 cm/sec [20 in/sec])

**Storage** 105 G +/- 5% with pulse duration of 2 msec +/-10% (equivalent to 127 cm/sec [50 in/sec])

**Maximum Altitude:**



|                  |                                      |
|------------------|--------------------------------------|
| <b>Operating</b> | -15.2 to 3048 m (-50 to 10,000 ft)   |
| <b>Storage</b>   | -15.2 to 10,668 m (-50 to 35,000 ft) |



# System setup

System setup enables you to manage your notebook hardware and specify BIOS level options. From the System setup, you can:

- Change the NVRAM settings after you add or remove hardware
- View the system hardware configuration
- Enable or disable integrated devices
- Set performance and power management thresholds
- Manage your computer security

Topics:

- [Boot menu](#)
- [Navigation keys](#)
- [System setup options](#)
- [Updating the BIOS in Windows](#)
- [System and setup password](#)

## Boot menu

Press <F12> when the Dell logo appears to initiate a one-time boot menu with a list of the valid boot devices for the system. Diagnostics and BIOS Setup options are also included in this menu. The devices listed on the boot menu depend on the bootable devices in the system. This menu is useful when you are attempting to boot to a particular device or to bring up the diagnostics for the system. Using the boot menu does not make any changes to the boot order stored in the BIOS.

The options are:

- UEFI Boot:
  - Windows Boot Manager
- Other Options:
  - BIOS Setup
  - BIOS Flash Update
  - Diagnostics
  - Change Boot Mode Settings

## Navigation keys

**NOTE:** For most of the System Setup options, changes that you make are recorded but do not take effect until you restart the system.

| Keys       | Navigation                   |
|------------|------------------------------|
| Up arrow   | Moves to the previous field. |
| Down arrow | Moves to the next field.     |



|                 |   |
|-----------------|---|
| <b>Keys</b>     | <b>Navigation</b>   |
| <b>Enter</b>    | Selects a value in the selected field (if applicable) or follow the link in the field.  |
| <b>Spacebar</b> | Expands or collapses a drop-down list, if applicable.   |
| <b>Tab</b>      | Moves to the next focus area.   |
|                 |  <b>NOTE:</b> For the standard graphics browser only.  |
| <b>Esc</b>      | Moves to the previous page until you view the main screen. Pressing Esc in the main screen displays a message that prompts you to save any unsaved changes and restarts the system. |

## System setup options

 **NOTE:** Depending on the notebook and its installed devices, the items listed in this section may or may not appear.

## General options

Table 20. General

| Option                         | Description   |
|--------------------------------|---|
| <b>System Information</b>      | <p>This section lists the primary hardware features of your computer.</p> <p>The options are:</p> <ul style="list-style-type: none"> <li>• <b>System Information</b></li> <li>• <b>Memory Configuration</b></li> <li>• <b>Processor Information</b></li> <li>• <b>Device Information</b></li> </ul>   |
| <b>Battery Information</b>     | <p>Displays the battery status and the type of AC adapter connected to the computer.</p>  |
| <b>Boot Sequence</b>           | <p>Allows you to change the order in which the computer attempts to find an operating system.</p> <p>The options are:</p> <ul style="list-style-type: none"> <li>• <b>Windows Boot Manager</b></li> <li>• <b>Boot List Option:</b><br/>Allows you to change the boot list options.</li> </ul> <p>Click one of the following options:</p> <ul style="list-style-type: none"> <li>– <b>Legacy</b></li> <li>– <b>UEFI</b>—Default</li> </ul> |
| <b>Advanced Boot Options</b>   | <p>Allows you to Enable Legacy Option ROMs.</p> <p>The options are:</p> <ul style="list-style-type: none"> <li>• <b>Enable Legacy Option ROMs</b>—Default</li> <li>• <b>Enable Attempt Legacy Boot</b></li> <li>• <b>Enable UEFI Network Stack</b></li> </ul>   |
| <b>UEFI Boot Path Security</b> | <p>Allows you to control whether the system prompts the user to enter the Admin password when booting to a UEFI boot path.</p>  |

| Option           | Description  |
|------------------|--|
|                  | <p>Click one of the following options:</p> <ul style="list-style-type: none"> <li>• <b>Always, Except Internal HDD</b>—Default</li> <li>• <b>Always</b></li> <li>• <b>Never</b></li> </ul> |
| <b>Date/Time</b> | Allows you to set the date and time. The change to the system date and time takes effect immediately.  |

## System configuration

Table 21. System Configuration

| Option                   | Description  |
|--------------------------|--|
| <b>Integrated NIC</b>    | <p>Allows you to configure the integrated network controller.</p> <p>Click one of the following options:</p> <ul style="list-style-type: none"> <li>• <b>Disabled</b></li> <li>• <b>Enabled</b></li> <li>• <b>Enabled w/PXE</b>—Default</li> </ul>   |
| <b>SATA Operation</b>    | <p>Allows you to configure the operating mode of the integrated SATA hard-drive controller.</p> <p>Click one of the following options:</p> <ul style="list-style-type: none"> <li>• <b>Disabled</b></li> <li>• <b>AHCI</b></li> <li>• <b>RAID On</b>—Default</li> </ul> <p><b>NOTE:</b> SATA is configured to support RAID mode.</p>         |
| <b>Drives</b>            | <p>Allows you to enable or disable various drives on board.</p> <p>The options are:</p> <ul style="list-style-type: none"> <li>• <b>SATA-0</b></li> <li>• <b>SATA-1</b></li> <li>• <b>M.2 PCIe SSD-0</b></li> </ul> <p>All the options are set by default.</p>   |
| <b>SMART Reporting</b>   | <p>This field controls whether hard drive errors for integrated drives are reported during system startup. This technology is part of the SMART (Self Monitoring Analysis and Reporting Technology) specification. This option is disabled by default.</p> <ul style="list-style-type: none"> <li>• <b>Enable SMART Reporting</b></li> </ul> |
| <b>USB Configuration</b> | <p>Allows you to enable or disable the internal/integrated USB configuration.</p> <p>The options are:</p> <ul style="list-style-type: none"> <li>• <b>Enable USB Boot Support</b></li> </ul>   |



| Option                                   | Description   |
|--|---|
|  | <ul style="list-style-type: none"> <li>• <b>Enable External USB Ports</b></li> </ul> <p>All the options are set by default.</p> <p><b>NOTE:</b> USB keyboard and mouse always work in the BIOS setup irrespective of these settings.</p>  |
| <b>Thunderbolt Adapter Configuration</b> | <p>Allows you to configure the Thunderbolt adapter security settings within the operating system.</p> <p>The options are:</p> <ul style="list-style-type: none"> <li>• <b>Enable Thunderbolt Technology Support</b>—Default</li> <li>• <b>Enable Thunderbolt Adapter Boot Support</b></li> <li>• <b>Enable Thunderbolt Adapter Pre-boot Modules</b></li> </ul> <p>Choose any one option:</p> <ul style="list-style-type: none"> <li>• <b>Security level - No Security</b></li> <li>• <b>Security level - User Authorization</b>—Default</li> <li>• <b>Security level - Secure Connect</b></li> <li>• <b>Security level - Display Port Only</b></li> </ul> |
| <b>USB PowerShare</b>                    | <p>This field configures the USB PowerShare feature behavior. This option allows you to charge external devices using the stored system battery power through the USB PowerShare port (disabled by default).</p> <ul style="list-style-type: none"> <li>• <b>Enable USB PowerShare</b></li> </ul>   |
| <b>Audio</b>                             | <p>Allows you to enable or disable the integrated audio controller. By default, the <b>Enable Audio</b> option is selected.</p> <p>The options are:</p> <ul style="list-style-type: none"> <li>• <b>Enable Microphone</b></li> <li>• <b>Enable Internal Speaker</b></li> </ul> <p>This option is set by default.</p>  |
| <b>Keyboard Illumination</b>             | <p>This field lets you choose the operating mode of the keyboard illumination feature. The keyboard brightness level can be set from 0% to 100%.</p> <p>The options are:</p> <ul style="list-style-type: none"> <li>• <b>Disabled</b></li> <li>• <b>Dim</b></li> <li>• <b>Bright</b>—Default</li> </ul>   |
| <b>Keyboard Backlight Timeout on AC</b>  | <p>Allows to define the timeout value for the keyboard backlight when an AC adapter is plugged in the system. The Keyboard Backlight timeout value is only in effect when the backlight is enabled.</p> <ul style="list-style-type: none"> <li>• <b>5 seconds</b></li> <li>• <b>10 seconds</b>—Default</li> <li>• <b>15 seconds</b></li> <li>• <b>30 seconds</b></li> <li>• <b>1 minute</b></li> <li>• <b>5 minutes</b></li> </ul>  |

| Option                                       | Description  |
|--|--|
|  | <ul style="list-style-type: none"> <li>• <b>15 minutes</b></li> <li>• <b>Never</b></li> </ul>  |
| <b>Keyboard Backlight Timeout on Battery</b> | <p>Allows to define the timeout value for the keyboard backlight when the system is running only on battery power. The Keyboard Backlight timeout value is only in effect when the backlight is enabled.</p> <ul style="list-style-type: none"> <li>• <b>5 seconds</b></li> <li>• <b>10 seconds</b>—Default</li> <li>• <b>15 seconds</b></li> <li>• <b>30 seconds</b></li> <li>• <b>1 minute</b></li> <li>• <b>5 minutes</b></li> <li>• <b>15 minutes</b></li> <li>• <b>Never</b></li> </ul> |
| <b>Miscellaneous devices</b>                 | <p>Allows you to enable or disable the following devices:</p> <ul style="list-style-type: none"> <li>• <b>Enable Camera</b></li> <li>• <b>Enable Hard Drive Free Fall Protection</b></li> </ul> <p>This options are set by default.</p>  |

## Video screen options

Table 22. Video



| Option                | Description  |
|-----------------------|--|
| <b>LCD Brightness</b> | <p>Allows you to set the display brightness depending upon the power source. On Battery(50% is default) and On AC (100 % default).</p> |

## Security

Table 23. Security

| Option                | Description   |
|-----------------------|---|
| <b>Admin Password</b> | <p>Allows you to set, change, or delete the administrator(admin) password.</p> <p>The entries to set password are:</p> <ul style="list-style-type: none"> <li>• <b>Enter the old password:</b></li> <li>• <b>Enter the new password:</b></li> <li>• <b>Confirm new password:</b></li> </ul> <p>Click <b>OK</b> once you set the password.</p> |



| Option                         | Description  |
|--------------------------------|--|
|                                | <p> <b>NOTE:</b> For the first time login, "Enter the old password:" field is marked to "Not set". Hence, password has to be set for the first time you login and then you can change or delete the password.</p>   |
| <b>System Password</b>         | <p>Allows you to set, change, or delete the System password.</p> <p>The entries to set password are:</p> <ul style="list-style-type: none"> <li>• <b>Enter the old password:</b></li> <li>• <b>Enter the new password:</b></li> <li>• <b>Confirm new password:</b></li> </ul> <p>Click <b>OK</b> once you set the password.</p> <p> <b>NOTE:</b> For the first time login, "Enter the old password:" field is marked to "Not set". Hence, password has to be set for the first time you login and then you can change or delete the password.</p>   |
| <b>Internal HDD-0 Password</b> | <p>Allows you to set, change, or delete the password on the system's internal hard disk drive (HDD).</p> <p>The entries to set password are:</p> <ul style="list-style-type: none"> <li>• <b>Enter the old password:</b></li> <li>• <b>Enter the new password:</b></li> <li>• <b>Confirm new password:</b></li> </ul> <p>Click <b>OK</b> once you set the password.</p> <p> <b>NOTE:</b> For the first time login, "Enter the old password:" field is marked to "Not set". Hence, password has to be set for the first time you login and then you can change or delete the password.</p> |
| <b>Strong Password</b>         | <p>Allows you to enforce the option to always set strong password.</p> <ul style="list-style-type: none"> <li>• <b>Enable Strong Password</b></li> </ul> <p>This option is not set by default.</p>   |
| <b>Password Configuration</b>  | <p>You can define the length of your password. Min = 4, Max = 32</p>   |
| <b>Password Bypass</b>         | <p>Allows you to bypass the System password and the Internal HDD password, when it is set, during a system restart.</p> <p>Click one of the options:</p> <ul style="list-style-type: none"> <li>• <b>Disabled</b>—Default</li> <li>• <b>Reboot bypass</b></li> </ul>   |
| <b>Password Change</b>         | <p>Allows you to change the System password when the administrator password is set.</p> <ul style="list-style-type: none"> <li>• <b>Allow Non-Admin Password Changes</b></li> </ul> <p>This option is set by default.</p>  |
| <b>Non-Admin Setup Changes</b> | <p>Allows you to determine whether changes to the setup options are allowed when an Administrator Password is set. If disabled the setup options are locked by the admin password.</p> <ul style="list-style-type: none"> <li>• <b>Allow Wireless Switch Changes</b></li> </ul> <p>This option is not set by default.</p>  |

| Option                               | Description  |
|--------------------------------------|--|
| <b>UEFI Capsule Firmware Updates</b> | <p>Allows you to update the system BIOS via UEFI capsule update packages.</p> <ul style="list-style-type: none"> <li>• <b>Enable UEFI Capsule Firmware Updates</b></li> </ul> <p>This option is set by default.</p>  |
| <b>PTT Security</b>                  | <p>Allows you to enable or disable the Platform Trust Technology (PTT) during POST.</p> <p>The options are:</p> <ul style="list-style-type: none"> <li>• <b>PTT On</b>—Default</li> <li>• <b>Clear</b></li> <li>• <b>PPI Bypass for Clear Command</b></li> </ul>   |
| <b>Computrace (R)</b>                | <p>Allows you to activate or disable the optional Computrace software.</p> <p>The options are:</p> <ul style="list-style-type: none"> <li>• <b>Deactivate</b></li> <li>• <b>Disable</b></li> <li>• <b>Activate</b>—Default</li> </ul>  |
| <b>Admin Setup Lockout</b>           | <p>Allows you to prevent users from entering Setup when an administrator password is set.</p> <ul style="list-style-type: none"> <li>• <b>Enable Admin Setup Lockout</b></li> </ul> <p>This option is not set by default.</p>  |
| <b>Master Password Lockout</b>       | <p>Allows you to disable master password support.</p> <ul style="list-style-type: none"> <li>• <b>Enable Master Password Lockout</b></li> </ul> <p>This option is not set by default.</p> <p>   <b>NOTE:</b> Hard Disk password should be cleared before the settings can be changed.</p> |

## Secure boot

Table 24. Secure Boot

| Option                       | Description  |
|------------------------------|--|
| <b>Secure Boot Enable</b>    | <p>Allows you to enable or disable the Secure Boot Feature.</p> <ul style="list-style-type: none"> <li>• <b>Secure Boot Enable</b>—Default</li> </ul>  |
| <b>Secure Boot Mode</b>      | <p>Changes to the Secure Boot operation mode modifies the behaviour of Secure Boot to allow evaluation of UEFI driver signatures.</p> <p>Choose one of the option:</p> <ul style="list-style-type: none"> <li>• <b>Deployed Mode</b>—Default</li> <li>• <b>Audit Mode</b></li> </ul> |
| <b>Expert Key Management</b> | <p>Allows you to enable or disable Expert Key Management.</p> <ul style="list-style-type: none"> <li>• <b>Enable Custom Mode</b></li> </ul>  |



| Option | Description   |
|--------|---|
|        | <p>This option is not set by default.</p> <p>The Custom Mode Key Management options are:</p> <ul style="list-style-type: none"> <li>· <b>PK</b>—Default</li> <li>· <b>KEK</b></li> <li>· <b>db</b></li> <li>· <b>dbx</b></li> </ul> |

## Intel Software Guard Extensions options

Table 25. Intel Software Guard Extensions

| Option                     | Description   |
|----------------------------|---|
| <b>Intel SGX Enable</b>    | <p>This field specifies you to provide a secured environment for running code/storing sensitive information in the context of the main OS.</p> <p>Click one of the following options:</p> <ul style="list-style-type: none"> <li>· <b>Disabled</b></li> <li>· <b>Enabled</b></li> <li>· <b>Software controlled</b>—Default</li> </ul> |
| <b>Enclave Memory Size</b> | <p>This option sets <b>SGX Enclave Reserve Memory Size</b></p> <p>Click one of the following options:</p> <ul style="list-style-type: none"> <li>· <b>32 MB</b></li> <li>· <b>64 MB</b></li> <li>· <b>128 MB</b>—Default</li> </ul>   |

## Performance

Table 26. Performance

| Option                    | Description   |
|---------------------------|---|
| <b>Multi Core Support</b> | <p>This field specifies whether the process has one or all cores enabled. The performance of some applications improves with the additional cores.</p> <ul style="list-style-type: none"> <li>· <b>All</b>—Default</li> <li>· <b>1</b></li> <li>· <b>2</b></li> <li>· <b>3</b></li> </ul> |
| <b>Intel SpeedStep</b>    | <p>Allows you to enable or disable the Intel SpeedStep mode of processor.</p> <ul style="list-style-type: none"> <li>· <b>Enable Intel SpeedStep</b></li> </ul>   |

| Option                      | Description   |
|-----------------------------|---|
|                             | This option is set by default.  |
| <b>C-States Control</b>     | <p>Allows you to enable or disable the additional processor sleep states.</p> <ul style="list-style-type: none"> <li>• <b>C states</b></li> </ul> <p>This option is set by default.</p>                     |
| <b>Intel TurboBoost</b>     | <p>Allows you to enable or disable the Intel TurboBoost mode of the processor.</p> <ul style="list-style-type: none"> <li>• <b>Enable Intel TurboBoost</b></li> </ul> <p>This option is set by default.</p> |
| <b>Hyper-Thread Control</b> | <p>Allows you to enable or disable the HyperThreading in the processor.</p> <ul style="list-style-type: none"> <li>• <b>Disabled</b></li> <li>• <b>Enabled</b>—Default</li> </ul>                           |

## Power management

Table 27. Power Management

| Option                                     | Description  |
|--|--|
| <b>AC Behavior</b>                         | <p>Allows you to enable or disable the computer from turning on automatically when an AC adapter is connected.</p> <ul style="list-style-type: none"> <li>• <b>Wake on AC</b></li> </ul> <p>This option is not set by default.</p>   |
| <b>Enable Intel Speed Shift Technology</b> | <p>Allows you to enable or disable the Intel Speed Shift Technology.</p> <ul style="list-style-type: none"> <li>• <b>Enabled</b>—Default</li> </ul>  |
| <b>Auto On Time</b>                        | <p>Allows you to set the time at which the computer must turn on automatically.</p> <p>The options are:</p> <ul style="list-style-type: none"> <li>• <b>Disabled</b>—Default</li> <li>• <b>Every Day</b></li> <li>• <b>Weekdays</b></li> <li>• <b>Select Days</b></li> </ul> <p>This option is not set by default.</p> |
| <b>USB Wake Support</b>                    | <p>Allows you to enable USB devices to wake the system from standby.</p> <ul style="list-style-type: none"> <li>• <b>Enable USB Wake Support</b></li> </ul> <p>This option is not set by default.</p>  |



| Option                                       | Description   |
|--|---|
| <b>Wake on LAN</b>                           | <p>This option allows the computer to power up from the off state when triggered by a special LAN signal. Wake-up from the Standby state is unaffected by this setting and must be enabled in the operating system. This feature only works when the computer is connected to AC power supply.</p> <ul style="list-style-type: none"> <li>• <b>Disabled</b>—Default - Does not allow the system to power on by special LAN signals when it receives a wake-up signal from the LAN or wireless LAN.</li> <li>• <b>LAN Only</b> - Allows the system to be powered on by special LAN signals.</li> </ul>   |
| <b>Advanced Battery Charge Configuration</b> | <p>This option enables you to maximize the battery health. By enabling this option, your system uses the standard charging algorithm and other techniques, during the non-work hours to improve the battery health.</p>   |
| <b>Primary Battery Charge Configuration</b>  | <p>Allows you to select the charging mode for the battery.</p> <p>The options are:</p> <ul style="list-style-type: none"> <li>• <b>Adaptive</b>—Default</li> <li>• <b>Standard</b> - Fully charges your battery at a standard rate.</li> <li>• <b>ExpressCharge</b>- The battery charges over a shorter period of time using Dell's fast charging technology.</li> <li>• <b>Primarily AC use</b></li> <li>• <b>Custom</b></li> </ul> <p>If Custom Charge is selected, you can also configure Custom Charge Start and Custom Charge Stop.</p> <p> <b>NOTE: All charging mode may not be available for all the batteries. To enable this option, disable the Advanced Battery Charge Configuration option.</b></p> |

## Post behavior

Table 28. POST Behavior

| Option                  | Description  |
|-------------------------|--|
| <b>Adapter Warnings</b> | <p>Allows you to enable or disable the system setup (BIOS) warning messages when you use certain power adapters.</p> <ul style="list-style-type: none"> <li>• <b>Enable Adapter Warnings</b>—Default</li> </ul>  |
| <b>Numlock Enable</b>   | <p>Allows you to enable or disable the Numlock function when the system boots.</p> <ul style="list-style-type: none"> <li>• <b>Enable Numlock</b>—Default</li> </ul>   |
| <b>Fn Lock Options</b>  | <p>Allows you to let hot key combinations Fn + Esc toggle the primary behavior of F1–F12, between their standard and secondary functions. If you disable this option, you cannot toggle dynamically the primary behavior of these keys.</p> <ul style="list-style-type: none"> <li>• <b>Fn Lock</b>—Default</li> </ul> <p>Click one of the following options:</p> <ul style="list-style-type: none"> <li>• <b>Lock Mode Disable/Standard</b></li> <li>• <b>Lock Mode Enable/Secondary</b>—Default</li> </ul> |
| <b>Fastboot</b>         | <p>Allows you to speed up the boot process by bypassing some of the compatibility steps.</p> <p>Click one of the following options:</p> <ul style="list-style-type: none"> <li>• <b>Minimal</b></li> </ul>   |

| Option                         | Description  |
|--------------------------------|--|
|                                | <ul style="list-style-type: none"> <li>• <b>Thorough</b>—Default</li> <li>• <b>Auto</b></li> </ul>   |
| <b>Extended BIOS POST Time</b> | <p>Allows you to create an additional preboot delay.</p> <p>Click one of the following options:</p> <ul style="list-style-type: none"> <li>• <b>0 seconds</b>—Default</li> <li>• <b>5 seconds</b></li> <li>• <b>10 seconds</b></li> </ul>  |
| <b>Full Screen Logo</b>        | <p>Allows you to display full screen logo, if your image matches screen resolution.</p> <ul style="list-style-type: none"> <li>• <b>Enable Full Screen Logo</b></li> </ul> <p>This option is not set by default.</p>   |
| <b>Sign of Life Indication</b> | <p>Allows the system to indicate during POST that the power button press has been acknowledged by turning on the keyboard backlight.</p>   |
| <b>Warnings and Errors</b>     | <p>Allows you to select different options to either stop, prompt and wait for user input, continue when warnings are detected but pause on errors, or continue when either warnings or errors are detected during the POST process.</p> <p>Click one of the following options:</p> <ul style="list-style-type: none"> <li>• <b>Prompt on Warnings and Errors</b>—Default</li> <li>• <b>Continue on Warnings</b></li> <li>• <b>Continue on Warnings and Errors</b></li> </ul> |

## Virtualization support

Table 29. Virtualization Support

| Option                   | Description  |
|--------------------------|--|
| <b>Virtualization</b>    | <p>This option specifies whether a Virtual Machine Monitor (VMM) can utilize the additional hardware capabilities provided by the Intel Virtualization technology.</p> <ul style="list-style-type: none"> <li>• <b>Enable Intel Virtualization Technology</b></li> </ul> <p>This option is set by default.</p> |
| <b>VT for Direct I/O</b> | <p>Enables or disables the Virtual Machine Monitor (VMM) from utilizing the additional hardware capabilities provided by the Intel Virtualization technology for direct I/O.</p> <ul style="list-style-type: none"> <li>• <b>Enable VT for Direct I/O</b></li> </ul> <p>This option is set by default.</p>     |

# Wireless options

Table 30. Wireless

| Option                        | Description   |
|-------------------------------|---|
| <b>Wireless Switch</b>        | <p>Allows to set the wireless devices that can be controlled by the wireless switch.</p> <p>The options are:</p> <ul style="list-style-type: none"> <li>• <b>WLAN</b></li> <li>• <b>Bluetooth</b></li> </ul> <p>All the options are enabled by default.</p> |
| <b>Wireless Device Enable</b> | <p>Allows you to enable or disable the internal wireless devices.</p> <p>The options are:</p> <ul style="list-style-type: none"> <li>• <b>WLAN</b></li> <li>• <b>Bluetooth</b></li> </ul> <p>All the options are enabled by default.</p>                    |

# Maintenance

Table 31. Maintenance

| Option                | Description  |
|-----------------------|--|
| <b>Service Tag</b>    | Displays the service tag of your computer.   |
| <b>Asset Tag</b>      | <p>Allows you to create a system asset tag if an asset tag is not already set.</p> <p>This option is not set by default.</p>   |
| <b>BIOS Downgrade</b> | <p>Allows you to flash previous revisions of the system firmware.</p> <ul style="list-style-type: none"> <li>• <b>Allow BIOS Downgrade</b></li> </ul> <p>This option is set by default.</p>  |
| <b>Data Wipe</b>      | <p>Allows you to securely erase data from all internal storage devices.</p> <ul style="list-style-type: none"> <li>• <b>Wipe on Next Boot</b></li> </ul> <p>This option is not set by default.</p>   |
| <b>Bios Recovery</b>  | <p><b>BIOS Recovery from Hard Drive</b>—This option is set by default. Allows you to recover the corrupted BIOS from a recovery file on the HDD or an external USB key.</p> <p><b>BIOS Auto-Recovery</b>— Allows you to recover the BIOS automatically.</p> <p>   <b>NOTE: BIOS Recovery from Hard Drive field should be enabled.</b></p> |

| Option | Description  |
|--------|--|
|        | <b>Always Perform Integrity Check</b> —Performs integrity check on every boot. |

## System logs

Table 32. System Logs

| Option                | Description   |
|-----------------------|---|
| <b>BIOS events</b>    | Allows you to view and clear the System Setup (BIOS) POST events. |
| <b>Thermal Events</b> | Allows you to view and clear the System Setup (Thermal) events.   |
| <b>Power Events</b>   | Allows you to view and clear the System Setup (Power) events.     |

## SupportAssist system resolution

Table 33. SupportAssist System Resolution

| Option                            | Description  |
|-----------------------------------|--|
| <b>Auto OS Recovery Threshold</b> | <p>The <b>Auto OS Recovery Threshold</b> setup option controls the automatic boot flow for Support Assist System Resolution Console and Dell OS Recovery tool.</p> <p>Click one of the following options:</p> <ul style="list-style-type: none"> <li>• <b>OFF</b></li> <li>• <b>1</b></li> <li>• <b>2</b>—Default</li> <li>• <b>3</b></li> </ul> |
| <b>SupportAssist OS Recovery</b>  | Allows you to recover the SupportAssist OS Recovery (Disabled by default)  |

## Updating the BIOS in Windows

It is recommended to update your BIOS (System Setup), when you replace the system board or if an update is available. For laptops, ensure that your computer battery is fully charged and connected to a power outlet

**NOTE:** If BitLocker is enabled, it must be suspended prior to updating the system BIOS, and then re-enabled after the BIOS update is completed.

- 1 Restart the computer.
- 2 Go to **Dell.com/support**.
  - Enter the **Service Tag** or **Express Service Code** and click **Submit**.
  - Click **Detect Product** and follow the instructions on screen.
- 3 If you are unable to detect or find the Service Tag, click **Choose from all products**.
- 4 Choose the **Products** category from the list.

**NOTE:** Choose the appropriate category to reach the product page

- 5 Select your computer model and the **Product Support** page of your computer appears.
- 6 Click **Get drivers** and click **Drivers and Downloads**.  
The Drivers and Downloads section opens.



- 7 Click **Find it myself**.
- 8 Click **BIOS** to view the BIOS versions.
- 9 Identify the latest BIOS file and click **Download**.
- 10 Select your preferred download method in the **Please select your download method below** window, click **Download File**.  
The **File Download** window appears.
- 11 Click **Save** to save the file on your computer.
- 12 Click **Run** to install the updated BIOS settings on your computer.  
Follow the instructions on the screen.

**NOTE:** It is recommended not to update the BIOS version for more than three revisions. For example: If you want to update the BIOS from 1.0 to 7.0, then install version 4.0 first and then install version 7.0.

## Updating BIOS on systems with bitlocker enabled

**CAUTION:** If BitLocker is not suspended before updating the BIOS, the next time you reboot the system it will not recognize the BitLocker key. You will then be prompted to enter the recovery key to progress and the system will ask for this on each reboot. If the recovery key is not known this can result in data loss or an unnecessary operating system re-install. For more information on this subject, see Knowledge Article: <http://www.dell.com/support/article/us/en/19/SLN153694/updating-bios-on-systems-with-bitlocker-enabled>

## Updating your system BIOS using a USB flash drive

If the system cannot load into Windows but there is still a need to update the BIOS, download the BIOS file using another system and save it to a bootable USB Flash Drive.

**NOTE:** You will need to use a bootable USB Flash drive. Please refer to the following article for further details: <http://www.dell.com/support/article/us/en/19/SLN143196/how-to-create-a-bootable-usb-flash-drive-using-dell-diagnostic-deployment-package--ddd->

- 1 Download the BIOS update .EXE file to another system.
- 2 Copy the file e.g. O9010A12.EXE onto the bootable USB Flash drive.
- 3 Insert the USB Flash drive into the system that requires the BIOS update.
- 4 Restart the system and press F12 when the Dell Splash logo appears to display the One Time Boot Menu.
- 5 Using arrow keys, select **USB Storage Device** and click Return.
- 6 The system will boot to a Diag C:\> prompt.
- 7 Run the file by typing the full filename e.g. O9010A12.exe and press Return.
- 8 The BIOS Update Utility will load, follow the instructions on screen.



Figure 4. DOS BIOS Update Screen

## Updating the Dell BIOS in Linux and Ubuntu environments

If you want to update the system BIOS in a Linux environment such as Ubuntu, see <http://www.dell.com/support/article/us/en/19/SLN171755/updating-the-dell-bios-in-linux-and-ubuntu-environments>.

## Flashing the BIOS from the F12 One-Time boot menu

Updating your system BIOS using a BIOS update .exe file copied to a FAT32 USB key and booting from the F12 one time boot menu.

### BIOS Update

You can run the BIOS update file from Windows using a bootable USB key or you can also update the BIOS from the F12 One-Time boot menu on the system.

Most Dell systems built after 2012 have this capability and you can confirm by booting your system to the F12 One-Time Boot Menu to see if BIOS FLASH UPDATE is listed as a boot option for your system. If the option is listed, then the BIOS supports this BIOS update option.

**NOTE:** Only systems with BIOS Flash Update option in the F12 One-Time Boot Menu can use this function.

### Updating from the One-Time Boot Menu

To update your BIOS from the F12 One-Time boot menu, you will need:

- USB key formatted to the FAT32 file system (key does not have to be bootable)
- BIOS executable file that you downloaded from the Dell Support website and copied to the root of the USB key
- AC power adapter connected to the system
- Functional system battery to flash the BIOS

Perform the following steps to execute the BIOS update flash process from the F12 menu:

**CAUTION:** Do not power off the system during the BIOS update process. Powering off the system could make the system fail to boot.

- 1 From a power off state, insert the USB key where you copied the flash into a USB port of the system .
- 2 Power on the system and press the F12 key to access the One-Time Boot Menu, Highlight BIOS Flash Update using the arrow keys then press **Enter**.



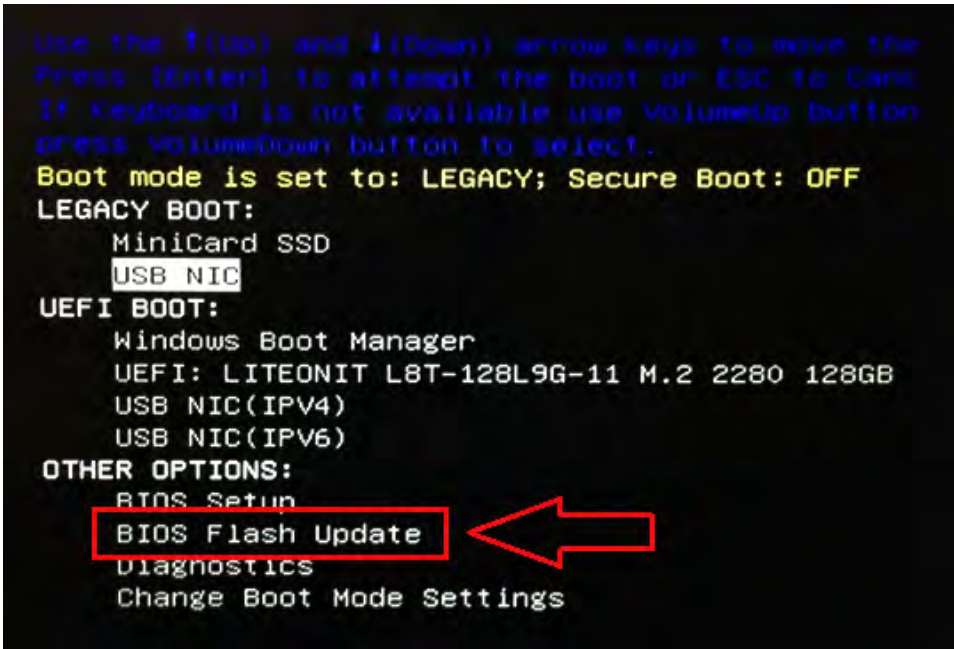

- 3 The Bios flash menu will open then click the browse button.

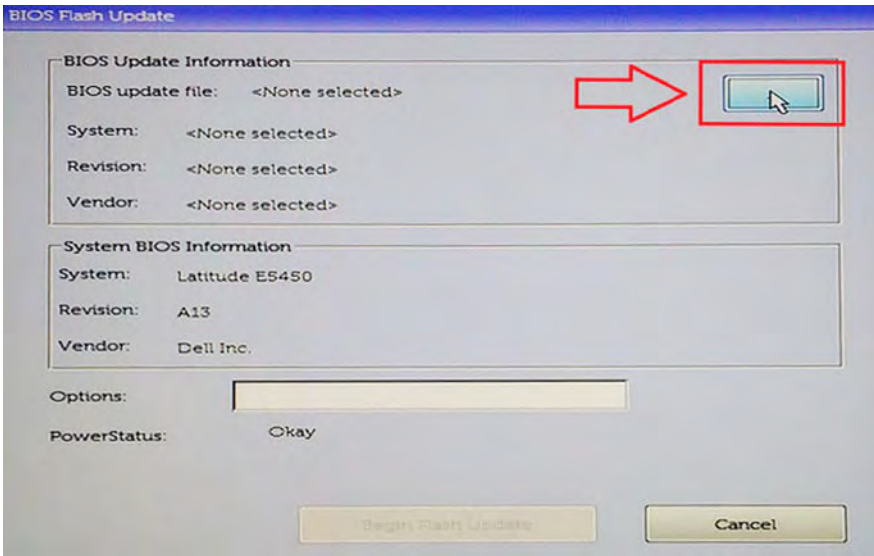

- 4 The E5450A14.exe file is shown as an example in the following screenshot. The actual file name may vary.

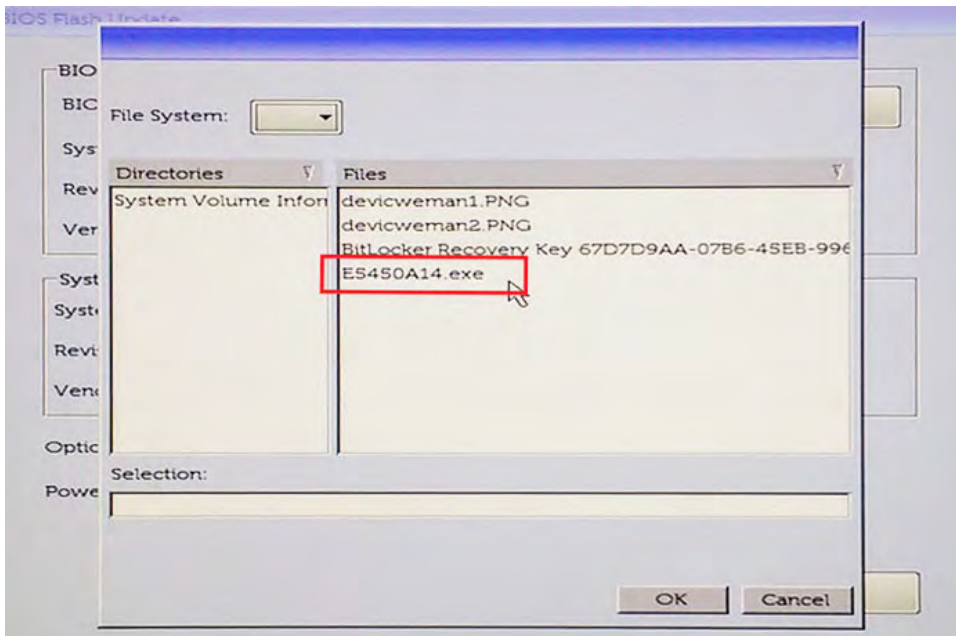

- 5 Once the file is selected, it will show in the file selection box and you can click the OK button to continue.

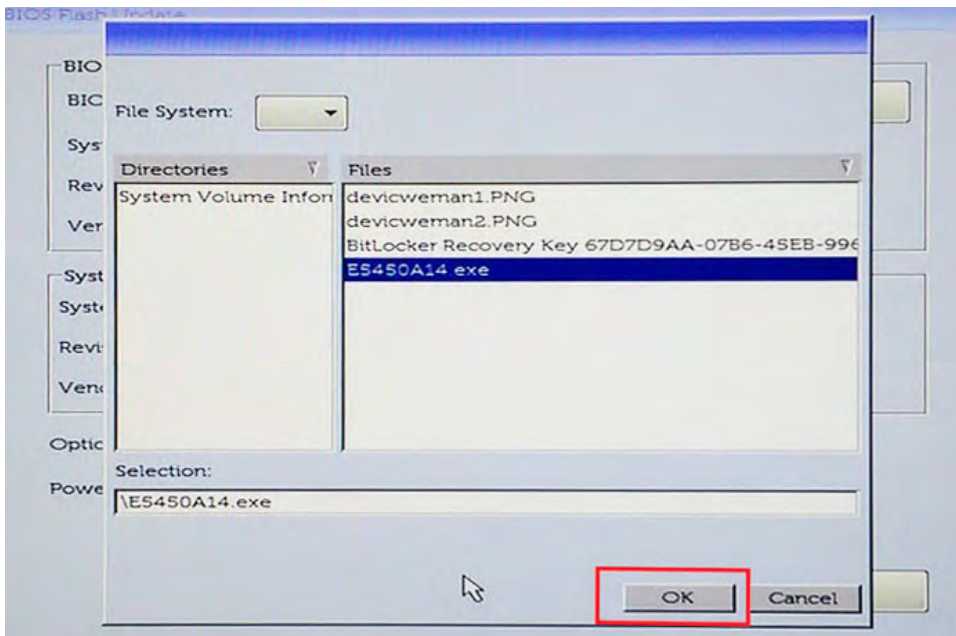

- 6 Click the **Begin Flash Update** button.

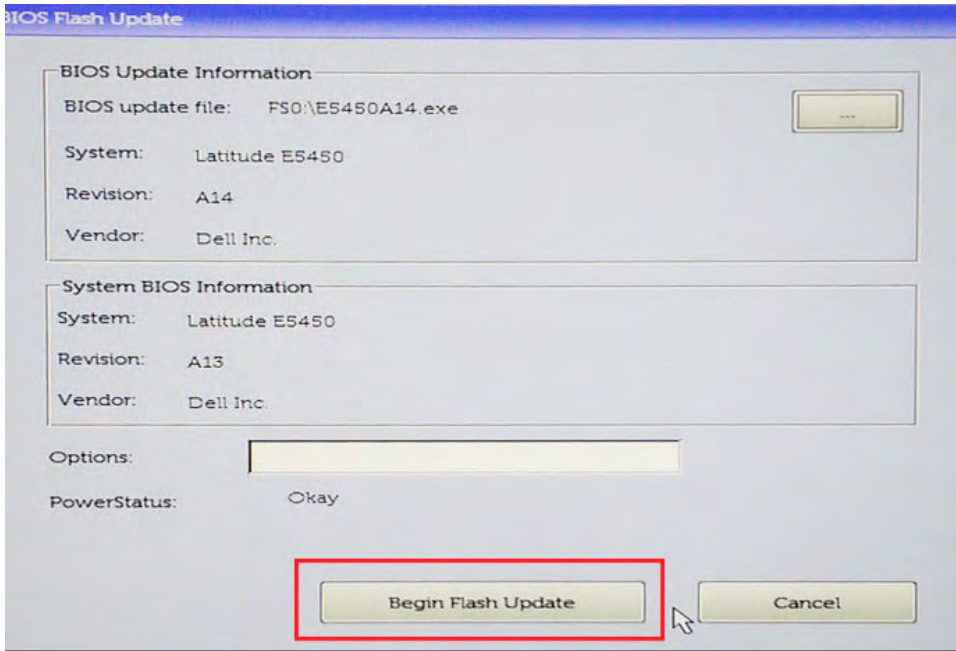

- 7 A warning box is displayed asking you if you want to proceed. Click the Yes button to begin the flash.

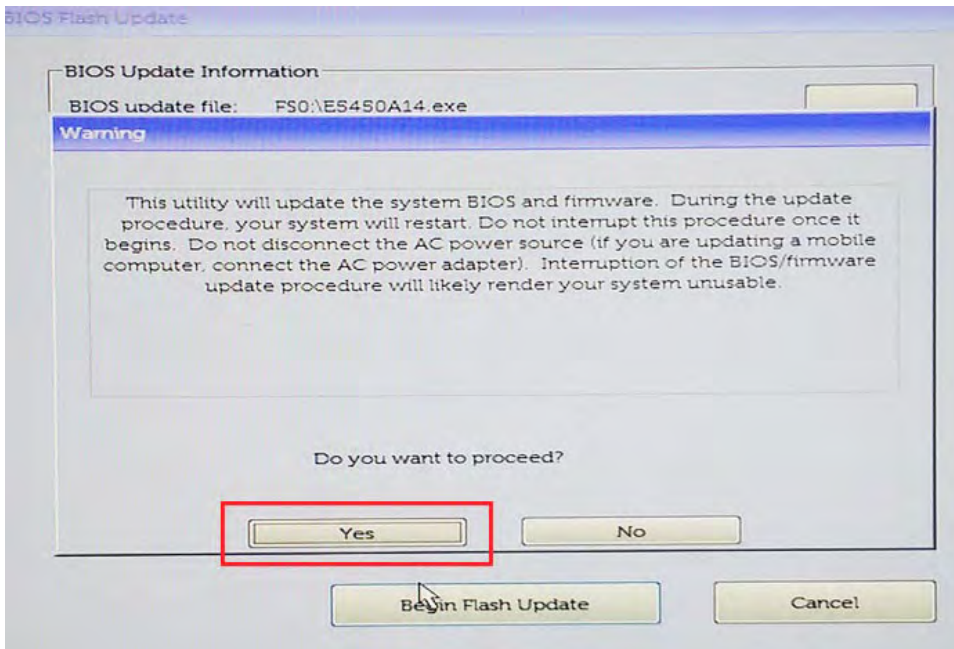

- 8 At this point the BIOS flash will execute, the system will reboot and then the BIOS flash will start and a progress bar will show the progress of the flash. Depending on the changes included in the update, the progress bar may go from zero to 100 multiple times and the flash process could take as long as 10 minutes. Generally this process takes two to three minutes.

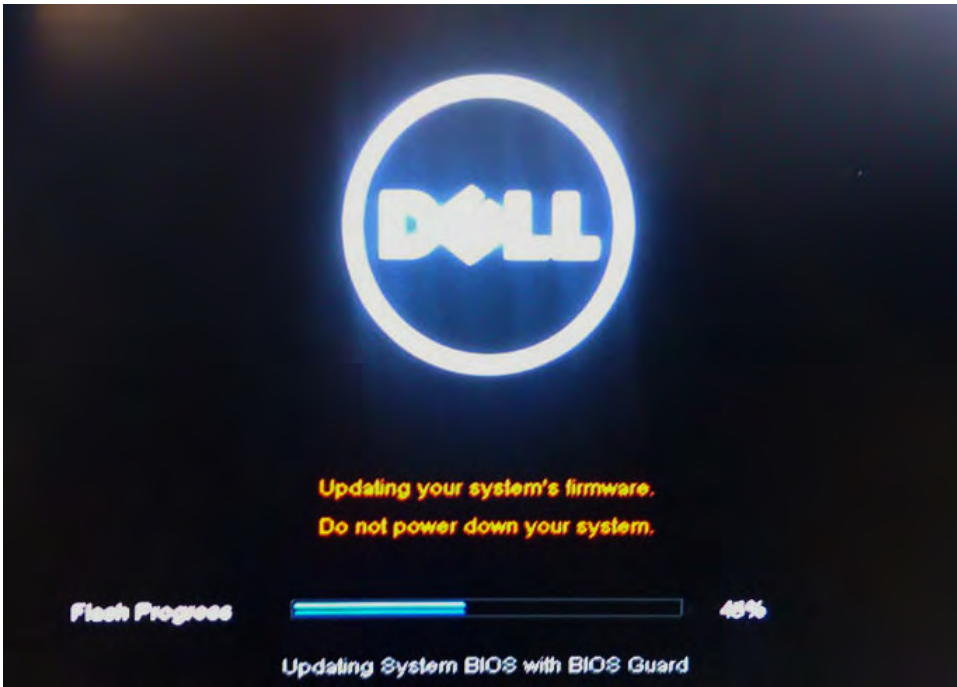

9 Once complete, the system will reboot and the BIOS update process is completed.

## System and setup password

Table 34. System and setup password

| Password type   | Description  |
|-----------------|--|
| System password | Password that you must enter to log on to your system.   |
| Setup password  | Password that you must enter to access and make changes to the BIOS settings of your computer. |

You can create a system password and a setup password to secure your computer.

**⚠ CAUTION:** The password features provide a basic level of security for the data on your computer.

**⚠ CAUTION:** Anyone can access the data stored on your computer if it is not locked and left unattended.

**📌 NOTE:** System and setup password feature is disabled.

## Assigning a system password and setup password

You can assign a new **System Password** only when the status is in **Not Set**.

To enter the system setup, press F2 immediately after a power-on or re-boot.

- 1 In the **System BIOS** or **System Setup** screen, select **Security** and press Enter.  
The **Security** screen is displayed.
- 2 Select **System Password** and create a password in the **Enter the new password** field.  
Use the following guidelines to assign the system password:
  - A password can have up to 32 characters.
  - The password can contain the numbers 0 through 9.



- Only lower case letters are valid, upper case letters are not allowed.
  - Only the following special characters are allowed: space, ("), (+), (,), (-), (.), (/), (:), ([), (\), (]), (`).
- 3 Type the system password that you entered earlier in the **Confirm new password** field and click **OK**.
  - 4 Press Esc and a message prompts you to save the changes.
  - 5 Press Y to save the changes.  
The computer reboots.

## Deleting or changing an existing system setup password

Ensure that the **Password Status** is Unlocked (in the System Setup) before attempting to delete or change the existing System and/or Setup password. You cannot delete or change an existing System or Setup password, if the **Password Status** is Locked. To enter the System Setup, press F2 immediately after a power-on or reboot.

- 1 In the **System BIOS** or **System Setup** screen, select **System Security** and press Enter.  
The **System Security** screen is displayed.
- 2 In the **System Security** screen, verify that **Password Status** is **Unlocked**.
- 3 Select **System Password**, alter or delete the existing system password and press Enter or Tab.
- 4 Select **Setup Password**, alter or delete the existing setup password and press Enter or Tab.

**NOTE:** If you change the System and/or Setup password, re-enter the new password when promoted. If you delete the System and/or Setup password, confirm the deletion when promoted.

- 5 Press Esc and a message prompts you to save the changes.
- 6 Press Y to save the changes and exit from System Setup.  
The computer reboot.

# Software

This chapter details the supported operating systems along with instructions on how to install the drivers.

Topics:

- [Operating system configurations](#)
- [Chipset drivers](#)
- [USB drivers](#)
- [Network drivers](#)
- [Audio drivers](#)
- [Storage controller drivers](#)
- [Bluetooth drivers](#)
- [Security drivers](#)

## Operating system configurations

This topic lists the operating system supported by Vostro 7580

**Table 35. Operating systems**

|            |   |
|------------|---|
| Windows 10 | <ul style="list-style-type: none"> <li>· Microsoft Windows 10 Home 64 bit</li> <li>· Microsoft Windows10 Professional 64 bit</li> </ul> |
| Others     | <ul style="list-style-type: none"> <li>· Ubuntu 16.04 LTS 64-bit</li> </ul>   |

## Chipset drivers

Verify if the Intel chipset and Intel Management Engine Interface drivers are already installed in the computer.



- System devices
  - ACPI Fixed Feature Button
  - ACPI Lid
  - ACPI Power Button
  - ACPI Processor Aggregator
  - ACPI Sleep Button
  - ACPI Thermal Zone
  - Composite Bus Enumerator
  - High Definition Audio Controller
  - High precision event timer
  - Intel(R) Power Engine Plug-in
  - Microsoft ACPI-Compliant Embedded Controller
  - Microsoft ACPI-Compliant System
  - Microsoft System Management BIOS Driver
  - Microsoft UEFI-Compliant System
  - Microsoft Virtual Drive Enumerator
  - Microsoft Windows Management Interface for ACPI
  - Microsoft Windows Management Interface for ACPI
  - Microsoft Windows Management Interface for ACPI
  - Microsoft Windows Management Interface for ACPI
  - Microsoft Windows Management Interface for ACPI
  - Microsoft Windows Management Interface for ACPI
  - NDIS Virtual Network Adapter Enumerator
  - Numeric data processor
  - PCI Express Root Complex
  - PCI standard host CPU bridge
  - PCI standard ISA bridge
  - PCI standard RAM Controller
  - PCI-to-PCI Bridge
  - PCI-to-PCI Bridge
  - PCI-to-PCI Bridge
  - PCI-to-PCI Bridge
  - Plug and Play Software Device Enumerator
  - Programmable interrupt controller
  - Remote Desktop Device Redirector Bus
  - System CMOS/real time clock
  - System timer
  - UMBus Root Bus Enumerator

## USB drivers

Verify if the USB drivers are already installed in the computer.

- Universal Serial Bus controllers
  - Intel(R) USB 3.1 eXtensible Host Controller - 1.10 (Microsoft)
  - USB Composite Device
  - USB Composite Device
  - USB Root Hub (xHCI)

## Network drivers

The driver is labeled as Intel I219-LM Ethernet Driver.

- Network adapters
  - Bluetooth Device (Personal Area Network)
  - Bluetooth Device (RFCOMM Protocol TDI)
  - Dell Wireless 1820 802.11ac

## Audio drivers

Verify if the audio drivers are already installed in the computer.

- Audio inputs and outputs
  - Microphone (2- High Definition Audio Device)
  - Speakers (2- High Definition Audio Device)
- Sound, video and game controllers
  - High Definition Audio Device
  - High Definition Audio Device

## Storage controller drivers

Verify if the storage controller drivers are already installed in the computer.

- Storage controllers
  - Intel(R) Desktop/Workstation/Server Express Chipset SATA RAID Controller
  - Microsoft Storage Spaces Controller



## Bluetooth drivers

This platform supports a variety of Bluetooth drivers. The following is an example.

- Bluetooth
  - Generic Bluetooth Adapter
  - Microsoft Bluetooth Enumerator
  - Microsoft Bluetooth LE Enumerator

## Security drivers

Verify if the security drivers are already installed in the system.

- ▼  Security devices
  -  Trusted Platform Module 2.0

# Troubleshooting

## Enhanced Pre-Boot System Assessment — ePSA diagnostics

The ePSA diagnostics (also known as system diagnostics) performs a complete check of your hardware. The ePSA is embedded with the BIOS and is launched by the BIOS internally. The embedded system diagnostics provides a set of options for particular devices or device groups allowing you to:

- Run tests automatically or in an interactive mode
- Repeat tests
- Display or save test results
- Run thorough tests to introduce additional test options to provide extra information about the failed device(s)
- View status messages that inform you if tests are completed successfully
- View error messages that inform you of problems encountered during testing

**⚠ CAUTION: Use the system diagnostics to test only your computer. Using this program with other computers may cause invalid results or error messages.**

**ℹ NOTE: Some tests for specific devices require user interaction. Always ensure that you are present at the computer terminal when the diagnostic tests are performed.**

## Running the ePSA Diagnostics

- 1 Invoke diagnostics boot by either of the methods suggested above
- 2 Once on one time boot menu use up/down arrow key to navigate to ePSA or diagnostics and press <return> key to launch
- 1 Fn+PWR will flash diagnostics boot selected on screen and launch ePSA/diagnostics directly.
- 3 On the boot menu screen, select the **Diagnostics** option.
- 4 Press the arrow in the lower-right corner to go to the page listing.  
The items detected are listed and will be tested
- 5 If there are any issues, error codes are displayed.  
Note the error code and validation number and contact Dell.
- 2 To run a diagnostic test on a specific device
- 6 Press Esc and click **Yes** to stop the diagnostic test.
- 7 Select the device from the left pane and click **Run Tests**.
- 8 Repeat [Step 4](#) and [Step 8](#)

## Diagnostic LED

This section details the diagnostic features of the battery LED in a notebook.

Instead of beep codes errors are indicated via the bicolor Battery Charge LED. A specific blink pattern is followed by flashing a pattern of flashes in amber, followed by white. The pattern then repeats.

**ℹ NOTE: The diagnostic pattern will consist of a two digit number being represented by a first group of LED blinks (1 through 9) in amber, followed by a 1.5 second pause with the LED off, and then a second group of LED blinks (1 through 9) in white. This is then followed by a three second pause, with the LED off, before repeating over again. Each LED blink takes 0.5 seconds.**



The system will not shutdown when displaying the Diagnostic Error Codes. Diagnostic Error Codes will always supersede any other use of the LED. For instance, on Notebooks, battery codes for Low Battery or Battery Failure situations will not be displayed when Diagnostic Error Codes are being displayed:

**Table 36. LED pattern**

| Blinking pattern |       | Problem Description    | Suggested Resolution                              |
|------------------|-------|------------------------|---|
| Amber            | White |                        |   |
| 2                | 1     | processor              | processor failure                                 |
| 2                | 2     | system board, BIOS ROM | system board, covers BIOS corruption or ROM error |
| 2                | 3     | memory                 | no memory/no RAM detected                         |
| 2                | 4     | memory                 | memory failure/RAM failure                        |
| 2                | 5     | memory                 | invalid memory installed                          |
| 2                | 6     | system board; chipset  | system board/ chipset error                       |
| 2                | 7     | display                | display failure                                   |
| 3                | 1     | RTC power failure      | coin-cell battery failure                         |
| 3                | 2     | PCI/Video              | PCI/Video card/chip failure                       |
| 3                | 3     | BIOS recovery 1        | recovery image not found                          |
| 3                | 4     | BIOS recovery 2        | recovery image found but invalid                  |

## Battery status lights

If the computer is connected to an electrical outlet, the battery light operates as follows:

|   |   |
|---|---|
| <b>Alternately blinking amber light and white light</b>         | An unauthenticated or unsupported non-Dell AC adapter is attached to your laptop. Re-plug battery connector, replace battery if the issue reoccurs. |
| <b>Alternately blinking amber light with steady white light</b> | Temporary battery failure with AC adapter present. Re-plug battery connector, replace battery if the issue reoccurs.                                |
| <b>Constantly blinking amber light</b>                          | Fatal battery failure with AC adapter present. Fetal battery, replace the battery.  |
| <b>Light off</b>  | Battery in full charge mode with AC adapter present.  |
| <b>White light on</b>   | Battery in charge mode with AC adapter present.   |

## Dell Docking Solution

### Thunderbolt 3 Type-C port does not support certain docking systems features

The Vostro 15-7580 system do not support all of the Dell Docking solution features of the Dell Thunderbolt Dock TB16, Dell Dock WD15, Dell Universal Dock D6000, as well as third-party docking solutions features.

**NOTE:** The Dell Power Manager (DPM V3.0) will pop up an alert message informing you of this issue.

**Table 37. Dell Docking solution features not supported**

| Features                                   | Description   |
|--|---|
| Power Delivery                             | Allows Dell Docks (Thunderbolt Dock TB16 / Dell Dock WD15/ Dell Universal Dock D6000) to provide power input through the Type-C connector.  |
| Power/ Wake on dock button                 | Ability to power on laptops by using the dock button (Dell Thunderbolt Dock TB16 and Dell Dock WD15)  |
| Port Disablement                           | Allows IT managers to turn off ports in the dock for securing confidential information (Dell Thunderbolt Dock TB16 and Dell Dock WD15)  |
| Error Message and Dock Event Notifications | User will be notified when an insufficient power adapter or cable is paired with the dock and advised to use the recommended accessory. Notifications of firmware updates and port disablement. Examples include Wake on LAN and LAN Cable detect (Dell Thunderbolt Dock TB16 and Dell Dock WD15) |
| Wake on dock attached                      | Dock will power on the system automatically (Dell Thunderbolt Dock TB16 and Dell Dock WD15)   |
| Cable FW updates                           | Ability to receive future enhancements or fixes from Dell (Dell Thunderbolt Dock TB16 and Dell Dock WD15)   |
| Cable LED                                  | Indicates dock connection status (Dell Thunderbolt Dock TB16 and Dell Dock WD15)  |
| Run Time MAC address Overwrite             | Bypasses the docking MAC address so IT professionals can identify the user by the notebook/Tablet MAC address and not the common address in the docking stations (Dell Thunderbolt Dock TB16 and Dell Dock WD15)  |
| Dock firmware updates                      | Ability to receive future enhancements or fixes from Dell (Dell Thunderbolt Dock TB16 and Dell Dock WD15)   |
| LAN Cable detection                        | WLAN/WWAN is auto disabled when LAN is attached to the dock (Dell Thunderbolt Dock TB16 and Dell Dock WD15)   |

## Third-party docking solutions features

- The Vostro 15-7580 system supports standard Thunderbolt 3 protocol/features on external graphic docks. However, performance has not been validated in many third-party Thunderbolt 3 eGfx docks and so users may experience certain unexpected compatibility issues.

## Hybrid Power

Users may observe certain behaviors when the system is heavily loaded or in certain gaming conditions, such as:

- Battery capacity does not increase even when connected to the power adapter.
- Battery charges slowly when connected to the power adapter.

The hybrid power feature in the Vostro 15–7580 systems enable the battery to output power to the system during heavy loading and in certain gaming conditions to support overall system power demand (as long as battery capacity is above 10 %).

Battery charging will resume immediately as soon as the system exits the heavy loading condition.



# Getting help

## Contacting Dell

**NOTE:** If you do not have an active Internet connection, you can find contact information on your purchase invoice, packing slip, bill, or Dell product catalog.

Dell provides several online and telephone-based support and service options. Availability varies by country and product, and some services may not be available in your area. To contact Dell for sales, technical support, or customer service issues:

- 1 Go to **Dell.com/support**.
- 2 Select your support category.
- 3 Verify your country or region in the **Choose a Country/Region** drop-down list at the bottom of the page.
- 4 Select the appropriate service or support link based on your need.