



**Hewlett Packard
Enterprise**

HPE ProLiant ML110 Gen10 Server Maintenance and Service Guide

Abstract

This guide describes identification and maintenance procedures, diagnostic tools, specifications and requirements for hardware components and software. This guide is for an experienced service technician. Hewlett Packard Enterprise assumes that you are qualified in the servicing of computer equipment, trained in recognizing hazards in products, and are familiar with weight and stability precautions.

Part Number: 874622-002
Published: February 2018
Edition: 2

Notices

The information contained herein is subject to change without notice. The only warranties for Hewlett Packard Enterprise products and services are set forth in the express warranty statements accompanying such products and services. Nothing herein should be construed as constituting an additional warranty. Hewlett Packard Enterprise shall not be liable for technical or editorial errors or omissions contained herein.

Confidential computer software. Valid license from Hewlett Packard Enterprise required for possession, use, or copying. Consistent with FAR 12.211 and 12.212, Commercial Computer Software, Computer Software Documentation, and Technical Data for Commercial Items are licensed to the U.S. Government under vendor's standard commercial license.

Links to third-party websites take you outside the Hewlett Packard Enterprise website. Hewlett Packard Enterprise has no control over and is not responsible for information outside the Hewlett Packard Enterprise website.

Acknowledgments

Intel[®], Itanium[®], Pentium[®], Intel Inside[®], and the Intel Inside logo are trademarks of Intel Corporation in the United States and other countries.

Microsoft[®] and Windows[®] are either registered trademarks or trademarks of Microsoft Corporation in the United States and/or other countries.

Contents

| | |
|---|-----------|
| Customer self repair..... | 7 |
| Illustrated parts catalog..... | 17 |
| Mechanical components..... | 17 |
| Redundant power supply blank spare part..... | 17 |
| SFF hard disk drive blank spare part..... | 18 |
| LFF hard disk drive blank spare part..... | 18 |
| Four-bay LFF non-hot-plug drive cage spare part..... | 18 |
| PCIe air baffle spare part..... | 18 |
| System components..... | 18 |
| Hot-plug power supply spare part..... | 19 |
| Redundant power supply backplane spare part..... | 20 |
| Non-hot-plug power supply spare part..... | 20 |
| Redundant fan module spare part..... | 20 |
| System battery spare part..... | 20 |
| System board assembly spare part..... | 20 |
| DIMM spare parts..... | 20 |
| Heatsink spare part..... | 21 |
| Processor spare parts..... | 21 |
| PCIe fan module spare part..... | 21 |
| System fan spare part..... | 21 |
| Server components..... | 22 |
| Four-bay LFF drive cage backplane spare part..... | 22 |
| Eight-bay SFF drive cage assembly spare part..... | 23 |
| Smart storage battery spare part..... | 23 |
| USB flash media device spare part..... | 23 |
| Cable spare parts..... | 23 |
| HPE Trusted Platform Module 2.0 spare part..... | 23 |
| Removal and replacement procedures..... | 25 |
| Safety considerations..... | 25 |
| Electrostatic discharge..... | 25 |
| Preventing electrostatic discharge..... | 25 |
| Grounding methods to prevent electrostatic discharge..... | 25 |
| Symbols on equipment..... | 25 |
| Server warnings and cautions..... | 26 |
| Required tools..... | 27 |
| Preparation procedures..... | 27 |
| Power down the server..... | 27 |
| Remove the server from the rack..... | 28 |
| Remove the access panel..... | 29 |
| Remove the front bezel..... | 31 |
| Remove the PCIe air baffle..... | 31 |
| Remove the system air baffle..... | 32 |
| Removing and replacing a drive blank..... | 33 |
| Removing and replacing an LFF drive blank..... | 33 |
| Removing and replacing an SFF drive blank..... | 34 |
| Removing and replacing drives..... | 34 |

| | |
|--|-----------|
| Removing and replacing the hot-plug drive..... | 34 |
| Removing and replacing the non-hot-plug drive..... | 35 |
| Replacing the front panel LEDs cable assembly..... | 36 |
| Replacing the front panel USB ports cable assembly..... | 37 |
| Replacing the iLO service port cable assembly..... | 38 |
| Replacing the serial port cable..... | 39 |
| Replacing the DIMM..... | 40 |
| Replacing the optical disc drive..... | 41 |
| Replacing the four-LFF non-hot-plug drive cage..... | 42 |
| Replacing the four-LFF drive backplane..... | 43 |
| Replacing the eight-SFF drive cage assembly..... | 45 |
| Replacing the M.2 SSD..... | 46 |
| Replacing the GPU..... | 47 |
| Replacing the internal USB device..... | 48 |
| Replacing the non-hot-plug power supply..... | 49 |
| Removing the power supply blank..... | 50 |
| Replacing the hot-plug power supply..... | 50 |
| Replacing the redundant power supply backplane module..... | 51 |
| Replacing fans..... | 53 |
| Replacing the PCIe fan module..... | 53 |
| Replacing the system fan module..... | 54 |
| Replacing the redundant fans..... | 55 |
| Replacing the redundant PCIe fan module..... | 55 |
| Replacing the redundant system fan module..... | 56 |
| System battery information..... | 57 |
| Replacing the system battery..... | 57 |
| Replacing the smart storage battery..... | 58 |
| Replacing the system board assembly..... | 59 |
| Re-entering the server serial number and product ID..... | 61 |
| HPE Trusted Platform Module 2.0 Gen10 Option..... | 61 |
| Troubleshooting..... | 62 |
| Troubleshooting resources..... | 62 |
| Diagnostic tools..... | 63 |
| Product QuickSpecs..... | 63 |
| UEFI System Utilities..... | 63 |
| Selecting the boot mode | 63 |
| Secure Boot..... | 64 |
| Launching the Embedded UEFI Shell | 64 |
| Intelligent Provisioning..... | 65 |
| Intelligent Provisioning operation..... | 65 |
| HPE Insight Remote Support..... | 66 |
| USB support..... | 67 |
| External USB functionality..... | 67 |
| HPE Smart Storage Administrator..... | 67 |
| Component identification..... | 68 |
| Front panel components..... | 68 |
| Front panel LEDs and buttons..... | 69 |
| Rear panel components..... | 70 |
| UID button functionality..... | 71 |
| Power fault LEDs..... | 71 |

| | |
|--|------------|
| Rear panel LEDs..... | 72 |
| System board components..... | 73 |
| System maintenance switch descriptions..... | 75 |
| DIMM slot locations..... | 76 |
| Drives..... | 76 |
| LFF drive LED definitions..... | 76 |
| Hot-plug drive LED definitions..... | 78 |
| Enabling embedded chipset SATA controller support..... | 78 |
| SFF SmartDrive components..... | 79 |
| Drive Numbering..... | 80 |
| Fan locations..... | 82 |
| Cabling..... | 83 |
| Cabling guidelines..... | 83 |
| Drive and Storage cabling..... | 84 |
| LFF non-hot-plug drive cabling..... | 84 |
| LFF hot-plug drive cabling..... | 85 |
| SFF hot-plug drive cabling..... | 87 |
| M.2 SSD cabling..... | 88 |
| Storage controller cabling..... | 89 |
| FBWC module cabling..... | 90 |
| Smart Storage Battery cabling..... | 91 |
| Serial port cabling..... | 92 |
| Front I/O cabling..... | 92 |
| Front USB 3.0 cabling..... | 93 |
| iLO service port cabling..... | 93 |
| Optical drive cabling..... | 94 |
| Fan cabling..... | 94 |
| Power supply cabling..... | 96 |
| Specifications..... | 99 |
| Environmental specifications..... | 99 |
| Server specifications..... | 99 |
| Power supply specifications..... | 100 |
| ATX 350W non-hot-plug power supply..... | 100 |
| ATX 550W non-hot-plug power supply..... | 100 |
| HPE 800W Flex Slot Platinum Hot Plug Low Halogen Power Supply..... | 101 |
| Hot-plug power supply calculations..... | 102 |
| Safety, warranty, and regulatory information..... | 103 |
| Safety and regulatory compliance..... | 103 |
| Warranty information..... | 103 |
| Belarus Kazakhstan Russia marking..... | 103 |
| Turkey RoHS material content declaration..... | 104 |
| Ukraine RoHS material content declaration..... | 104 |
| Websites..... | 105 |
| Support and other resources..... | 106 |
| Accessing Hewlett Packard Enterprise Support..... | 106 |
| Accessing updates..... | 106 |

| | |
|-----------------------------|-----|
| Customer self repair..... | 107 |
| Remote support..... | 107 |
| Documentation feedback..... | 107 |

Customer self repair

Hewlett Packard Enterprise products are designed with many Customer Self Repair (CSR) parts to minimize repair time and allow for greater flexibility in performing defective parts replacement. If during the diagnosis period Hewlett Packard Enterprise (or Hewlett Packard Enterprise service providers or service partners) identifies that the repair can be accomplished by the use of a CSR part, Hewlett Packard Enterprise will ship that part directly to you for replacement. There are two categories of CSR parts:

- **Mandatory**—Parts for which customer self repair is mandatory. If you request Hewlett Packard Enterprise to replace these parts, you will be charged for the travel and labor costs of this service.
- **Optional**—Parts for which customer self repair is optional. These parts are also designed for customer self repair. If, however, you require that Hewlett Packard Enterprise replace them for you, there may or may not be additional charges, depending on the type of warranty service designated for your product.

NOTE: Some Hewlett Packard Enterprise parts are not designed for customer self repair. In order to satisfy the customer warranty, Hewlett Packard Enterprise requires that an authorized service provider replace the part. These parts are identified as "No" in the Illustrated Parts Catalog.

Based on availability and where geography permits, CSR parts will be shipped for next business day delivery. Same day or four-hour delivery may be offered at an additional charge where geography permits. If assistance is required, you can call the Hewlett Packard Enterprise Support Center and a technician will help you over the telephone. Hewlett Packard Enterprise specifies in the materials shipped with a replacement CSR part whether a defective part must be returned to Hewlett Packard Enterprise. In cases where it is required to return the defective part to Hewlett Packard Enterprise, you must ship the defective part back to Hewlett Packard Enterprise within a defined period of time, normally five (5) business days. The defective part must be returned with the associated documentation in the provided shipping material. Failure to return the defective part may result in Hewlett Packard Enterprise billing you for the replacement. With a customer self repair, Hewlett Packard Enterprise will pay all shipping and part return costs and determine the courier/carrier to be used.

For more information about the Hewlett Packard Enterprise CSR program, contact your local service provider. For the North American program, go to the [Hewlett Packard Enterprise CSR website](#).

Parts only warranty service

Your Hewlett Packard Enterprise Limited Warranty may include a parts only warranty service. Under the terms of parts only warranty service, Hewlett Packard Enterprise will provide replacement parts free of charge.

For parts only warranty service, CSR part replacement is mandatory. If you request Hewlett Packard Enterprise to replace these parts, you will be charged for the travel and labor costs of this service.

Réparation par le client (CSR)

Les produits Hewlett Packard Enterprise comportent de nombreuses pièces CSR (Customer Self Repair = réparation par le client) afin de minimiser les délais de réparation et faciliter le remplacement des pièces défectueuses. Si pendant la période de diagnostic, Hewlett Packard Enterprise (ou ses partenaires ou mainteneurs agréés) détermine que la réparation peut être effectuée à l'aide d'une pièce CSR, Hewlett Packard Enterprise vous l'envoie directement. Il existe deux catégories de pièces CSR :

- **Obligatoire**—Pièces pour lesquelles la réparation par le client est obligatoire. Si vous demandez à Hewlett Packard Enterprise de remplacer ces pièces, les coûts de déplacement et main d'œuvre du service vous seront facturés.
- **Facultatif**—Pièces pour lesquelles la réparation par le client est facultative. Ces pièces sont également conçues pour permettre au client d'effectuer lui-même la réparation. Toutefois, si vous demandez à Hewlett Packard Enterprise de remplacer ces pièces, l'intervention peut ou non vous être facturée, selon le type de garantie applicable à votre produit.

REMARQUE: Certaines pièces Hewlett Packard Enterprise ne sont pas conçues pour permettre au client d'effectuer lui-même la réparation. Pour que la garantie puisse s'appliquer, Hewlett Packard Enterprise exige que le remplacement de la pièce soit effectué par un Mainteneur Agréé. Ces pièces sont identifiées par la mention "Non" dans le Catalogue illustré.

Les pièces CSR sont livrées le jour ouvré suivant, dans la limite des stocks disponibles et selon votre situation géographique. Si votre situation géographique le permet et que vous demandez une livraison le jour même ou dans les 4 heures, celle-ci vous sera facturée. Pour toute assistance, appelez le Centre d'assistance Hewlett Packard Enterprise pour qu'un technicien vous aide au téléphone. Dans les documents envoyés avec la pièce de rechange CSR, Hewlett Packard Enterprise précise s'il est nécessaire de lui retourner la pièce défectueuse. Si c'est le cas, vous devez le faire dans le délai indiqué, généralement cinq (5) jours ouvrés. La pièce et sa documentation doivent être retournées dans l'emballage fourni. Si vous ne retournez pas la pièce défectueuse, Hewlett Packard Enterprise se réserve le droit de vous facturer les coûts de remplacement. Dans le cas d'une pièce CSR, Hewlett Packard Enterprise supporte l'ensemble des frais d'expédition et de retour, et détermine la société de courses ou le transporteur à utiliser.

Pour plus d'informations sur le programme CSR de Hewlett Packard Enterprise, contactez votre Mainteneur Agréé local. Pour plus d'informations sur ce programme en Amérique du Nord, consultez le site [**Web Hewlett Packard Enterprise**](#).

Service de garantie "pièces seules"

Votre garantie limitée Hewlett Packard Enterprise peut inclure un service de garantie "pièces seules". Dans ce cas, les pièces de rechange fournies par Hewlett Packard Enterprise ne sont pas facturées.

Dans le cadre de ce service, la réparation des pièces CSR par le client est obligatoire. Si vous demandez à Hewlett Packard Enterprise de remplacer ces pièces, les coûts de déplacement et main d'œuvre du service vous seront facturés.

Riparazione da parte del cliente

Per abbreviare i tempi di riparazione e garantire una maggiore flessibilità nella sostituzione di parti difettose, i prodotti Hewlett Packard Enterprise sono realizzati con numerosi componenti che possono essere riparati direttamente dal cliente (CSR, Customer Self Repair). Se in fase di diagnostica Hewlett Packard Enterprise (o un centro di servizi o di assistenza Hewlett Packard Enterprise) identifica il guasto come riparabile mediante un ricambio CSR, Hewlett Packard Enterprise lo spedisce direttamente al cliente per la sostituzione. Vi sono due categorie di parti CSR:

- **Obbligatorie**—Parti che devono essere necessariamente riparate dal cliente. Se il cliente ne affida la riparazione ad Hewlett Packard Enterprise, deve sostenere le spese di spedizione e di manodopera per il servizio.
- **Opzionali**—Parti la cui riparazione da parte del cliente è facoltativa. Si tratta comunque di componenti progettati per questo scopo. Se tuttavia il cliente ne richiede la sostituzione ad Hewlett Packard Enterprise, potrebbe dover sostenere spese aggiuntive a seconda del tipo di garanzia previsto per il prodotto.

NOTA: alcuni componenti Hewlett Packard Enterprise non sono progettati per la riparazione da parte del cliente. Per rispettare la garanzia, Hewlett Packard Enterprise richiede che queste parti siano sostituite da

un centro di assistenza autorizzato. Tali parti sono identificate da un "No" nel Catalogo illustrato dei componenti.

In base alla disponibilità e alla località geografica, le parti CSR vengono spedite con consegna entro il giorno lavorativo seguente. La consegna nel giorno stesso o entro quattro ore è offerta con un supplemento di costo solo in alcune zone. In caso di necessità si può richiedere l'assistenza telefonica di un addetto del centro di supporto tecnico Hewlett Packard Enterprise. Nel materiale fornito con una parte di ricambio CSR, Hewlett Packard Enterprise specifica se il cliente deve restituire dei componenti. Qualora sia richiesta la resa ad Hewlett Packard Enterprise del componente difettoso, lo si deve spedire ad Hewlett Packard Enterprise entro un determinato periodo di tempo, generalmente cinque (5) giorni lavorativi. Il componente difettoso deve essere restituito con la documentazione associata nell'imballo di spedizione fornito. La mancata restituzione del componente può comportare la fatturazione del ricambio da parte di Hewlett Packard Enterprise. Nel caso di riparazione da parte del cliente, Hewlett Packard Enterprise sostiene tutte le spese di spedizione e resa e sceglie il corriere/vettore da utilizzare.

Per ulteriori informazioni sul programma CSR di Hewlett Packard Enterprise, contattare il centro di assistenza di zona. Per il programma in Nord America fare riferimento **al sito Web**.

Servizio di garanzia per i soli componenti

La garanzia limitata Hewlett Packard Enterprise può includere un servizio di garanzia per i soli componenti. Nei termini di garanzia del servizio per i soli componenti, Hewlett Packard Enterprise fornirà gratuitamente le parti di ricambio.

Per il servizio di garanzia per i soli componenti è obbligatoria la formula CSR che prevede la riparazione da parte del cliente. Se il cliente invece richiede la sostituzione ad Hewlett Packard Enterprise dovrà sostenere le spese di spedizione e di manodopera per il servizio.

Customer Self Repair

Hewlett Packard Enterprise Produkte enthalten viele CSR-Teile (Customer Self Repair), um Reparaturzeiten zu minimieren und höhere Flexibilität beim Austausch defekter Bauteile zu ermöglichen. Wenn Hewlett Packard Enterprise (oder ein Hewlett Packard Enterprise Servicepartner) bei der Diagnose feststellt, dass das Produkt mithilfe eines CSR-Teils repariert werden kann, sendet Ihnen Hewlett Packard Enterprise dieses Bauteil zum Austausch direkt zu. CSR-Teile werden in zwei Kategorien unterteilt:

- **Zwingend**—Teile, für die das Customer Self Repair-Verfahren zwingend vorgegeben ist. Wenn Sie den Austausch dieser Teile von Hewlett Packard Enterprise vornehmen lassen, werden Ihnen die Anfahrt- und Arbeitskosten für diesen Service berechnet.
- **Optional**—Teile, für die das Customer Self Repair-Verfahren optional ist. Diese Teile sind auch für Customer Self Repair ausgelegt. Wenn Sie jedoch den Austausch dieser Teile von Hewlett Packard Enterprise vornehmen lassen möchten, können bei diesem Service je nach den für Ihr Produkt vorgesehenen Garantiebedingungen zusätzliche Kosten anfallen.

HINWEIS: Einige Hewlett Packard Enterprise Teile sind nicht für Customer Self Repair ausgelegt. Um den Garantieanspruch des Kunden zu erfüllen, muss das Teil von einem Hewlett Packard Enterprise Servicepartner ersetzt werden. Im illustrierten Teilekatalog sind diese Teile mit „No“ bzw. „Nein“ gekennzeichnet.

CSR-Teile werden abhängig von der Verfügbarkeit und vom Lieferziel am folgenden Geschäftstag geliefert. Für bestimmte Standorte ist eine Lieferung am selben Tag oder innerhalb von vier Stunden gegen einen Aufpreis verfügbar. Wenn Sie Hilfe benötigen, können Sie das Hewlett Packard Enterprise Support Center anrufen und sich von einem Mitarbeiter per Telefon helfen lassen. Den Materialien von Hewlett Packard Enterprise, die mit einem CSR-Ersatzteil geliefert werden, können Sie entnehmen, ob das defekte Teil an Hewlett Packard Enterprise zurückgeschickt werden muss. Wenn es erforderlich ist, das defekte Teil an Hewlett Packard Enterprise zurückzuschicken, müssen Sie dies innerhalb eines vorgegebenen Zeitraums tun, in der Regel innerhalb von fünf (5) Geschäftstagen. Das defekte Teil muss mit der zugehörigen Dokumentation in der Verpackung zurückgeschickt werden, die im Lieferumfang enthalten ist. Wenn Sie das defekte Teil nicht zurückschicken, kann Hewlett Packard Enterprise Ihnen das

Ersatzteil in Rechnung stellen. Im Falle von Customer Self Repair kommt Hewlett Packard Enterprise für alle Kosten für die Lieferung und Rücksendung auf und bestimmt den Kurier-/Frachtdienst.

Weitere Informationen über das Hewlett Packard Enterprise Customer Self Repair Programm erhalten Sie von Ihrem Servicepartner vor Ort. Informationen über das CSR-Programm in Nordamerika finden Sie auf der **Hewlett Packard Enterprise Website unter**.

Parts-only Warranty Service (Garantieservice ausschließlich für Teile)

Ihre Hewlett Packard Enterprise Garantie umfasst möglicherweise einen Parts-only Warranty Service (Garantieservice ausschließlich für Teile). Gemäß den Bestimmungen des Parts-only Warranty Service stellt Hewlett Packard Enterprise Ersatzteile kostenlos zur Verfügung.

Für den Parts-only Warranty Service ist das CSR-Verfahren zwingend vorgegeben. Wenn Sie den Austausch dieser Teile von Hewlett Packard Enterprise vornehmen lassen, werden Ihnen die Anfahrt- und Arbeitskosten für diesen Service berechnet.

Reparaciones del propio cliente

Los productos de Hewlett Packard Enterprise incluyen muchos componentes que el propio usuario puede reemplazar (Customer Self Repair, CSR) para minimizar el tiempo de reparación y ofrecer una mayor flexibilidad a la hora de realizar sustituciones de componentes defectuosos. Si, durante la fase de diagnóstico, Hewlett Packard Enterprise (o los proveedores o socios de servicio de Hewlett Packard Enterprise) identifica que una reparación puede llevarse a cabo mediante el uso de un componente CSR, Hewlett Packard Enterprise le enviará dicho componente directamente para que realice su sustitución. Los componentes CSR se clasifican en dos categorías:

- **Obligatorio**—Componentes cuya reparación por parte del usuario es obligatoria. Si solicita a Hewlett Packard Enterprise que realice la sustitución de estos componentes, tendrá que hacerse cargo de los gastos de desplazamiento y de mano de obra de dicho servicio.
- **Opcional**—Componentes cuya reparación por parte del usuario es opcional. Estos componentes también están diseñados para que puedan ser reparados por el usuario. Sin embargo, si precisa que Hewlett Packard Enterprise realice su sustitución, puede o no conllevar costes adicionales, dependiendo del tipo de servicio de garantía correspondiente al producto.

NOTA: Algunos componentes de Hewlett Packard Enterprise no están diseñados para que puedan ser reparados por el usuario. Para que el usuario haga valer su garantía, Hewlett Packard Enterprise pone como condición que un proveedor de servicios autorizado realice la sustitución de estos componentes. Dichos componentes se identifican con la palabra "No" en el catálogo ilustrado de componentes.

Según la disponibilidad y la situación geográfica, los componentes CSR se enviarán para que lleguen a su destino al siguiente día laborable. Si la situación geográfica lo permite, se puede solicitar la entrega en el mismo día o en cuatro horas con un coste adicional. Si precisa asistencia técnica, puede llamar al Centro de asistencia técnica de Hewlett Packard Enterprise y recibirá ayuda telefónica por parte de un técnico. Con el envío de materiales para la sustitución de componentes CSR, Hewlett Packard Enterprise especificará si los componentes defectuosos deberán devolverse a Hewlett Packard Enterprise. En aquellos casos en los que sea necesario devolver algún componente a Hewlett Packard Enterprise, deberá hacerlo en el periodo de tiempo especificado, normalmente cinco días laborables. Los componentes defectuosos deberán devolverse con toda la documentación relacionada y con el embalaje de envío. Si no enviara el componente defectuoso requerido, Hewlett Packard Enterprise podrá cobrarle por el de sustitución. En el caso de todas sustituciones que lleve a cabo el cliente, Hewlett Packard Enterprise se hará cargo de todos los gastos de envío y devolución de componentes y escogerá la empresa de transporte que se utilice para dicho servicio.

Para obtener más información acerca del programa de Reparaciones del propio cliente de Hewlett Packard Enterprise, póngase en contacto con su proveedor de servicios local. Si está interesado en el programa para Norteamérica, visite **la página web de Hewlett Packard Enterprise CSR**.

Servicio de garantía exclusivo de componentes

La garantía limitada de Hewlett Packard Enterprise puede que incluya un servicio de garantía exclusivo de componentes. Según las condiciones de este servicio exclusivo de componentes, Hewlett Packard Enterprise le facilitará los componentes de repuesto sin cargo adicional alguno.

Para este servicio de garantía exclusivo de componentes, es obligatoria la sustitución de componentes por parte del usuario (CSR). Si solicita a Hewlett Packard Enterprise que realice la sustitución de estos componentes, tendrá que hacerse cargo de los gastos de desplazamiento y de mano de obra de dicho servicio.

Customer Self Repair

Veel onderdelen in Hewlett Packard Enterprise producten zijn door de klant zelf te repareren, waardoor de reparatieduur tot een minimum beperkt kan blijven en de flexibiliteit in het vervangen van defecte onderdelen groter is. Deze onderdelen worden CSR-onderdelen (Customer Self Repair) genoemd. Als Hewlett Packard Enterprise (of een Hewlett Packard Enterprise Service Partner) bij de diagnose vaststelt dat de reparatie kan worden uitgevoerd met een CSR-onderdeel, verzendt Hewlett Packard Enterprise dat onderdeel rechtstreeks naar u, zodat u het defecte onderdeel daarmee kunt vervangen. Er zijn twee categorieën CSR-onderdelen:

- **Verplicht**—Onderdelen waarvoor reparatie door de klant verplicht is. Als u Hewlett Packard Enterprise verzoekt deze onderdelen voor u te vervangen, worden u voor deze service reiskosten en arbeidsloon in rekening gebracht.
- **Optioneel**—Onderdelen waarvoor reparatie door de klant optioneel is. Ook deze onderdelen zijn ontworpen voor reparatie door de klant. Als u echter Hewlett Packard Enterprise verzoekt deze onderdelen voor u te vervangen, kunnen daarvoor extra kosten in rekening worden gebracht, afhankelijk van het type garantieservice voor het product.

OPMERKING: Sommige Hewlett Packard Enterprise onderdelen zijn niet ontwikkeld voor reparatie door de klant. In verband met de garantievoorwaarden moet het onderdeel door een geautoriseerde Service Partner worden vervangen. Deze onderdelen worden in de geïllustreerde onderdelencatalogus aangemerkt met "Nee".

Afhankelijk van de leverbaarheid en de locatie worden CSR-onderdelen verzonden voor levering op de eerstvolgende werkdag. Levering op dezelfde dag of binnen vier uur kan tegen meerkosten worden aangeboden, indien dit mogelijk is gezien de locatie. Indien assistentie is gewenst, belt u het Hewlett Packard Enterprise Support Center om via de telefoon ondersteuning van een technicus te ontvangen. Hewlett Packard Enterprise vermeldt in de documentatie bij het vervangende CSR-onderdeel of het defecte onderdeel aan Hewlett Packard Enterprise moet worden geretourneerd. Als het defecte onderdeel aan Hewlett Packard Enterprise moet worden teruggezonden, moet u het defecte onderdeel binnen een bepaalde periode, gewoonlijk vijf (5) werkdagen, retourneren aan Hewlett Packard Enterprise. Het defecte onderdeel moet met de bijbehorende documentatie worden geretourneerd in het meegeleverde verpakkingsmateriaal. Als u het defecte onderdeel niet terugzendt, kan Hewlett Packard Enterprise u voor het vervangende onderdeel kosten in rekening brengen. Bij reparatie door de klant betaalt Hewlett Packard Enterprise alle verzendkosten voor het vervangende en geretourneerde onderdeel en kiest Hewlett Packard Enterprise zelf welke koerier/transportonderneming hiervoor wordt gebruikt.

Neem contact op met een Service Partner voor meer informatie over het Customer Self Repair programma van Hewlett Packard Enterprise. Informatie over Service Partners vindt u op de **Hewlett Packard Enterprise website**.

Garantieservice "Parts Only"

Het is mogelijk dat de Hewlett Packard Enterprise garantie alleen de garantieservice "Parts Only" omvat. Volgens de bepalingen van de Parts Only garantieservice zal Hewlett Packard Enterprise kosteloos vervangende onderdelen ter beschikking stellen.

Voor de Parts Only garantieservice is vervanging door CSR-onderdelen verplicht. Als u Hewlett Packard Enterprise verzoekt deze onderdelen voor u te vervangen, worden u voor deze service reiskosten en arbeidsloon in rekening gebracht

Reparo feito pelo cliente

Os produtos da Hewlett Packard Enterprise são projetados com muitas peças para reparo feito pelo cliente (CSR) de modo a minimizar o tempo de reparo e permitir maior flexibilidade na substituição de peças com defeito. Se, durante o período de diagnóstico, a Hewlett Packard Enterprise (ou fornecedores/parceiros da Hewlett Packard Enterprise) concluir que o reparo pode ser efetuado pelo uso de uma peça CSR, a Hewlett Packard Enterprise enviará a peça diretamente ao cliente. Há duas categorias de peças CSR:

- **Obrigatória**—Peças cujo reparo feito pelo cliente é obrigatório. Se desejar que a Hewlett Packard Enterprise substitua essas peças, serão cobradas as despesas de transporte e mão-de-obra do serviço.
- **Opcional**—Peças cujo reparo feito pelo cliente é opcional. Essas peças também são projetadas para o reparo feito pelo cliente. No entanto, se desejar que a Hewlett Packard Enterprise as substitua, pode haver ou não a cobrança de taxa adicional, dependendo do tipo de serviço de garantia destinado ao produto.

OBSERVAÇÃO: Algumas peças da Hewlett Packard Enterprise não são projetadas para o reparo feito pelo cliente. A fim de cumprir a garantia do cliente, a Hewlett Packard Enterprise exige que um técnico autorizado substitua a peça. Essas peças estão identificadas com a marca "No" (Não), no catálogo de peças ilustrado.

Conforme a disponibilidade e o local geográfico, as peças CSR serão enviadas no primeiro dia útil após o pedido. Onde as condições geográficas permitirem, a entrega no mesmo dia ou em quatro horas pode ser feita mediante uma taxa adicional. Se precisar de auxílio, entre em contato com o Centro de suporte técnico da Hewlett Packard Enterprise para que um técnico o ajude por telefone. A Hewlett Packard Enterprise especifica nos materiais fornecidos com a peça CSR de reposição se a peça com defeito deve ser devolvida à Hewlett Packard Enterprise. Nos casos em que isso for necessário, é preciso enviar a peça com defeito à Hewlett Packard Enterprise, você deverá enviar a peça com defeito de volta para a Hewlett Packard Enterprise dentro do período de tempo definido, normalmente em 5 (cinco) dias úteis. A peça com defeito deve ser enviada com a documentação correspondente no material de transporte fornecido. Caso não o faça, a Hewlett Packard Enterprise poderá cobrar a reposição. Para as peças de reparo feito pelo cliente, a Hewlett Packard Enterprise paga todas as despesas de transporte e de devolução da peça e determina a transportadora/serviço postal a ser utilizado.

Para obter mais informações sobre o programa de reparo feito pelo cliente da Hewlett Packard Enterprise, entre em contato com o fornecedor de serviços local. Para o programa norte-americano, **visite o site da Hewlett Packard Enterprise**.

Serviço de garantia apenas para peças

A garantia limitada da Hewlett Packard Enterprise pode incluir um serviço de garantia apenas para peças. Segundo os termos do serviço de garantia apenas para peças, a Hewlett Packard Enterprise fornece as peças de reposição sem cobrar nenhuma taxa.

No caso desse serviço, a substituição de peças CSR é obrigatória. Se desejar que a Hewlett Packard Enterprise substitua essas peças, serão cobradas as despesas de transporte e mão-de-obra do serviço.

カスタマーセルフリペア

修理時間を短縮し、故障部品の交換における高い柔軟性を確保するために、Hewlett Packard Enterprise製品には多数のカスタマーセルフリペア（CSR）部品があります。診断の際に、CSR部品を使用すれば修理ができるとHewlett Packard Enterprise（Hewlett Packard EnterpriseまたはHewlett Packard Enterprise正規保守代理店）が判断した場合、Hewlett Packard Enterpriseはその部品を直接、お客様に発送し、お客様に交換していただきます。CSR部品には以下の2種類があります。

- **必須** - カスタマーセルフリペアが必須の部品。当該部品について、もしもお客様がHewlett Packard Enterpriseに交換作業を依頼される場合には、その修理サービスに関する交通費および人件費がお客様に請求されます。
- **任意** - カスタマーセルフリペアが任意である部品。この部品もカスタマーセルフリペア用です。当該部品について、もしもお客様がHewlett Packard Enterpriseに交換作業を依頼される場合には、お買い上げの製品に適用される保証サービス内容の範囲内においては、別途費用を負担していただくことなく保証サービスを受けることができます。

注：Hewlett Packard Enterprise製品の一部の部品は、カスタマーセルフリペアの対象外です。製品の保証を継続するためには、Hewlett Packard EnterpriseまたはHewlett Packard Enterprise正規保守代理店による交換作業が必須となります。部品カタログには、当該部品がカスタマーセルフリペア除外品である旨が記載されています。

部品供給が可能な場合、地域によっては、CSR部品を翌営業日に届くように発送します。また、地域によっては、追加費用を負担いただくことにより同日または4時間以内に届くように発送することも可能な場合があります。サポートが必要なときは、Hewlett Packard Enterpriseサポートセンターに電話していただければ、技術者が電話でアドバイスします。交換用のCSR部品または同梱物には、故障部品をHewlett Packard Enterpriseに返送する必要があるかどうかが表示されています。故障部品をHewlett Packard Enterpriseに返送する必要がある場合は、指定期限内（通常は5営業日以内）に故障部品をHewlett Packard Enterpriseに返送してください。故障部品を返送する場合は、届いた時の梱包箱に関連書類とともに入れてください。故障部品を返送しない場合、Hewlett Packard Enterpriseから部品費用が請求されます。カスタマーセルフリペアの際には、Hewlett Packard Enterpriseは送料および部品返送費を全額負担し、使用する宅配便会社や運送会社を指定します。

部品のみ保証サービス

Hewlett Packard Enterprise保証サービスには、部品のみ保証サービスが適用される場合があります。このサービスでは、交換部品は無償で提供されます。

部品のみ保証サービスにおいては、CSR部品をお客様により交換作業していただくことが必須となります。当該部品について、もしもお客様がHewlett Packard Enterpriseに交換作業を依頼される場合には、その修理サービスに関する交通費および人件費がお客様のご負担となります。

客户自行维修

Hewlett Packard Enterprise 产品提供许多客户自行维修 (CSR) 部件，以尽可能缩短维修时间和在更换缺陷部件方面提供更大的灵活性。如果在诊断期间 Hewlett Packard Enterprise (或 Hewlett Packard Enterprise 服务提供商或服务合作伙伴) 确定可以通过使用 CSR 部件完成维修，Hewlett Packard Enterprise 将直接把该部件发送给您进行更换。有两类 CSR 部件：

- **强制性的** — 要求客户必须自行维修的部件。如果您请求 Hewlett Packard Enterprise 更换这些部件，则必须为该服务支付差旅费和人工费用。
- **可选的** — 客户可以选择是否自行维修的部件。这些部件也是为客户自行维修设计的。不过，如果您要求 Hewlett Packard Enterprise 为您更换这些部件，则根据为您的产品指定的保修服务类型，Hewlett Packard Enterprise 可能收取或不再收取任何附加费用。

注：某些 Hewlett Packard Enterprise 部件的设计并未考虑客户自行维修。为了满足客户保修的需要，Hewlett Packard Enterprise 要求授权服务提供商更换相关部件。这些部件在部件图解目录中标记为“否”。

CSR 部件将在下一个工作日发运（取决于备货情况和允许的地理范围）。在允许的地理范围内，可在当天或四小时内发运，但要收取额外费用。如果需要帮助，您可以致电 Hewlett Packard Enterprise 技术支持中心，将会有技术人员通过电话为您提供帮助。Hewlett Packard Enterprise 会在随更换的 CSR 部件发运的材料中指明是否必须将有缺陷的部件退还给 Hewlett Packard Enterprise。如果要求您将缺陷的部件退还给 Hewlett Packard Enterprise，那么您必须在规定的期限内（通常是五 (5) 个工作日）将缺陷部件发给 Hewlett Packard Enterprise。有缺陷的部件必须随所提供的发运材料中的相关文件一起返还。如果未能送还有缺陷的部件，Hewlett Packard Enterprise 可能会要求您支付更换费用。客户自行维修时，Hewlett Packard Enterprise 将承担所有相关运输和部件返回费用，并指定快递商/承运商。

有关 Hewlett Packard Enterprise 客户自行维修计划的详细信息，请与您当地的服务提供商联系。有关北美地区的计划，请访问 Hewlett Packard Enterprise 网站 (<http://www.hpe.com/support/selfrepair>)。

仅部件保修服务

您的 Hewlett Packard Enterprise 有限保修服务可能涉及仅部件保修服务。根据仅部件保修服务条款的规定，Hewlett Packard Enterprise 将免费提供更换的部件。

仅部件保修服务要求进行 CSR 部件更换。如果您请求 Hewlett Packard Enterprise 更换这些部件，则必须为该服务支付差旅费和人工费用。

客戶自行維修

Hewlett Packard Enterprise 產品設計了許多「客戶自行維修」(CSR) 的零件以減少維修時間，並且使得更換瑕疵零件時能有更大的彈性。如果在診斷期間，Hewlett Packard Enterprise (或 Hewlett Packard Enterprise 服務供應商或維修夥伴) 辨認出此項維修工作可以藉由使用 CSR 零件來完成，則 Hewlett Packard Enterprise 將直接寄送該零件給您作更換。CSR 零件分為兩種類別：

- **強制的** — 客戶自行維修所使用的零件是強制性的。如果您要求 Hewlett Packard Enterprise 更換這些零件，Hewlett Packard Enterprise 將會向您收取此服務所需的外出費用與勞動成本。
- **選購的** — 客戶自行維修所使用的零件是選購的。這些零件也設計用於客戶自行維修之用。不過，如果您要求 Hewlett Packard Enterprise 為您更換，則可能需要也可能不需要負擔額外的費用，端視針對此產品指定的保固服務類型而定。

備註：某些 Hewlett Packard Enterprise 零件沒有消費者可自行維修的設計。為符合客戶保固，Hewlett Packard Enterprise 需要授權的服務供應商更換零件。這些零件在圖示的零件目錄中，被標示為「否」。

基於材料取得及環境允許的情況下，CSR 零件將於下一個工作日以快遞寄送。在環境的允許下當天或四小時內送達，則可能需要額外的費用。若您需要協助，可致電 Hewlett Packard Enterprise 支援中心，會有一位技術人員透過電話來協助您。不論損壞的零件是否必須退回，Hewlett Packard Enterprise 皆會在與 CSR 替換零件一起運送的材料中註明。若要將損壞的零件退回 Hewlett Packard Enterprise，您必須在指定的一段時間內 (通常為五 (5) 個工作天)，將損壞的零件寄回 Hewlett Packard Enterprise。損壞的零件必須與寄送資料中隨附的相關技術文件一併退還。如果無法退還損壞的零件，Hewlett Packard Enterprise 可能要向您收取替換費用。針對客戶自行維修情形，Hewlett Packard Enterprise 將負責所有運費及零件退還費用，並指定使用何家快遞/貨運公司。

如需 Hewlett Packard Enterprise 的 CSR 方案詳細資訊，請連絡您當地的服務供應商。至於北美方案，請參閱 Hewlett Packard Enterprise 的 CSR 網站 [repair \(http://www.hpe.com/support/selfrepair\)](http://www.hpe.com/support/selfrepair)。

僅限零件的保固服務

您的「Hewlett Packard Enterprise 有限保固」可能包含僅限零件的保固服務。在僅限零件的保固服務情況下，Hewlett Packard Enterprise 將免費提供替換零件。

針對僅限零件的保固服務，CSR 零件替換是強制性的。如果您要求 Hewlett Packard Enterprise 更換這些零件，Hewlett Packard Enterprise 將會向您收取此服務所需的外出費用與勞動成本。

고객 셀프 수리

Hewlett Packard Enterprise 제품은 수리 시간을 최소화하고 결함이 있는 부품 교체 시 더욱 용동성을 발휘할 수 있도록 하기 위해 고객 셀프 수리(CSR) 부품을 다량 사용하여 설계되었습니다. 진단 기간 동안 Hewlett Packard Enterprise(또는 Hewlett Packard Enterprise 서비스 공급업체 또는 서비스 협력업체)에서 CSR 부품을 사용하여 수리가 가능하다고 판단되면 Hewlett Packard Enterprise는 해당 부품을 바로 사용자에게 보내어 사용자가 교체할 수 있도록 합니다. CSR 부품에는 두 가지 종류가 있습니다.

- **필수** - 고객 셀프 수리가 의무 사항인 필수 부품. 사용자가 Hewlett Packard Enterprise에 이 부품의 교체를 요청할 경우 이 서비스에 대한 출장비 및 작업비가 청구됩니다.
- **선택 사항** - 고객 셀프 수리가 선택 사항인 부품. 이 부품들도 고객 셀프 수리가 가능하도록 설계되었습니다. 하지만 사용자가 Hewlett Packard Enterprise에 이 부품의 교체를 요청할 경우 사용자가 구입한 제품에 해당하는 보증 서비스 유형에 따라 추가 비용 없이 교체가 가능할 수 있습니다.

참고: 일부 Hewlett Packard Enterprise 제품은 고객 셀프 수리가 불가능하도록 설계되었습니다. Hewlett Packard Enterprise는 만족스러운 고객 보증을 위해 공인 서비스 제공업체를 통해 부품을 교체하도록 하고 있습니다. 이러한 부품들은 Illustrated Parts Catalog에 "No"라고 표시되어 있습니다.

CSR 부품은 재고 상태와 지리적 조건이 허용하는 경우 다음 영업일 납품이 가능하도록 배송이 이루어집니다. 지리적 조건이 허용하는 경우 추가 비용이 청구되는 조건으로 당일 또는 4시간 배송이 가능할 수도 있습니다. 도움이 필요하시면 Hewlett Packard Enterprise Support Center로 전화하십시오. 전문 기술자가 전화로 도움을 줄 것입니다. Hewlett Packard Enterprise는 결함이 발생한 부품을 Hewlett Packard Enterprise로 반환해야 하는지 여부를 CSR 교체 부품과 함께 배송된 자료에 지정합니다. 결함이 발생한 부품을 Hewlett Packard Enterprise로 반환해야 하는 경우에는 지정된 기간 내(통상 영업일 기준 5일)에 Hewlett Packard Enterprise로 반환해야 합니다. 이때 결함이 발생한 부품은 제공된 포장 재료에 넣어 관련 설명서와 함께 반환해야 합니다. 결함이 발생한 부품을 반환하지 않는 경우 Hewlett Packard Enterprise가 교체 부품에 대해 비용을 청구할 수 있습니다. 고객 셀프 수리의 경우, Hewlett Packard Enterprise는 모든 운송 및 부품 반환 비용을 부담하며 이용할 운송업체 및 택배 서비스를 결정합니다.

Hewlett Packard Enterprise CSR 프로그램에 대한 자세한 내용은 가까운 서비스 제공업체에 문의하십시오. 북미 지역의 프로그램에 대해서는 Hewlett Packard Enterprise CSR 웹 사이트(<http://www.hpe.com/support/selfrepair>)를 참조하십시오.

부품 제공 보증 서비스

Hewlett Packard Enterprise 제한 보증에는 부품 제공 보증 서비스가 포함될 수 있습니다. 이러한 경우 Hewlett Packard Enterprise는 부품 제공 보증 서비스의 조건에 따라 교체 부품만을 무료로 제공합니다.

부품 제공 보증 서비스 제공 시 CSR 부품 교체는 의무 사항입니다. 사용자가 Hewlett Packard Enterprise에 이 부품의 교체를 요청할 경우 이 서비스에 대한 출장비 및 작업비가 청구됩니다.

Illustrated parts catalog

This chapter lists the hardware spare parts supported by the server.

Mechanical components

Hewlett Packard Enterprise continually improves and changes product parts. For complete and current supported spare parts information, see the Hewlett Packard Enterprise PartSurfer website:

<http://www.hpe.com/info/partssurfer>

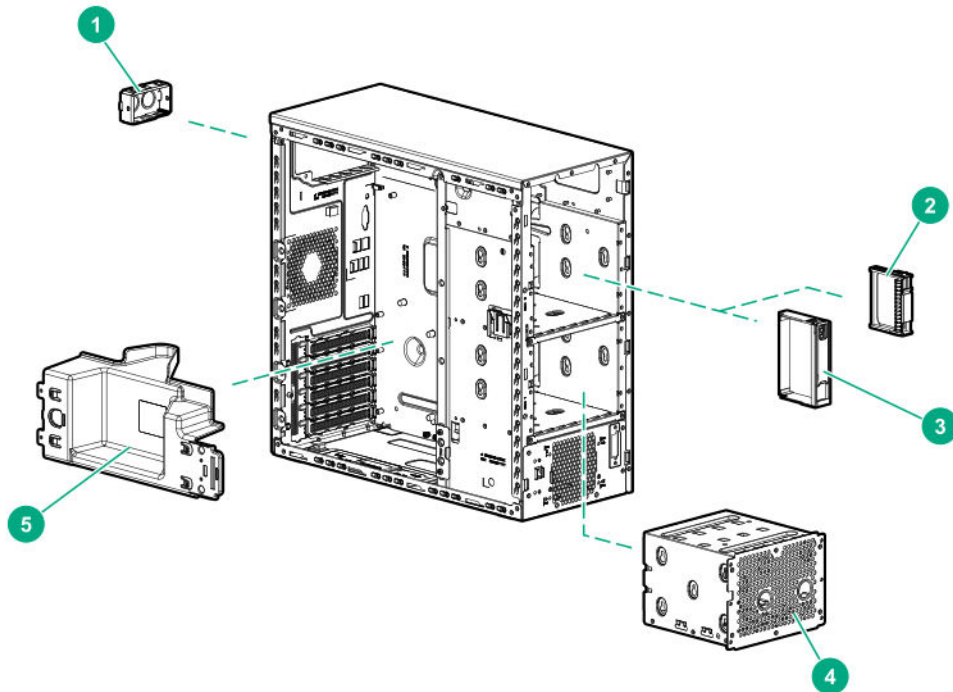

| Item | Description |
|------|---|
| 1 | <u>Redundant power supply blank spare part</u> |
| 2 | <u>SFF drive blank spare part</u> |
| 3 | <u>LFF drive blank spare part</u> |
| 4 | <u>Four-bay LFF non-hot-plug drive cage spare part</u> |
| 5 | <u>PCIe air baffle spare part</u> |

Redundant power supply blank spare part

Customer self repair on page 7: Mandatory

| Description | Spare part number |
|------------------------------|-------------------|
| Redundant power supply blank | 775423-001 |

SFF hard disk drive blank spare part

Customer self repair on page 7: Mandatory

| Description | Spare part number |
|---------------------------|-------------------|
| SFF hard disk drive blank | 670033-001 |

LFF hard disk drive blank spare part

Customer self repair on page 7: Mandatory

| Description | Spare part number |
|---------------------------|-------------------|
| LFF hard disk drive blank | 827363-001 |

Four-bay LFF non-hot-plug drive cage spare part

Customer self repair on page 7: Mandatory

| Description | Spare part number |
|--------------------------------------|-------------------|
| Four-bay LFF non-hot-plug drive cage | 792353-001 |

PCIe air baffle spare part

Customer self repair on page 7: Mandatory

| Description | Spare part number |
|-----------------|-------------------|
| PCIe air baffle | 791709-001 |

System components

Hewlett Packard Enterprise continually improves and changes product parts. For complete and current supported spare parts information, see the Hewlett Packard Enterprise PartSurfer website:

<http://www.hpe.com/info/partssurfer>

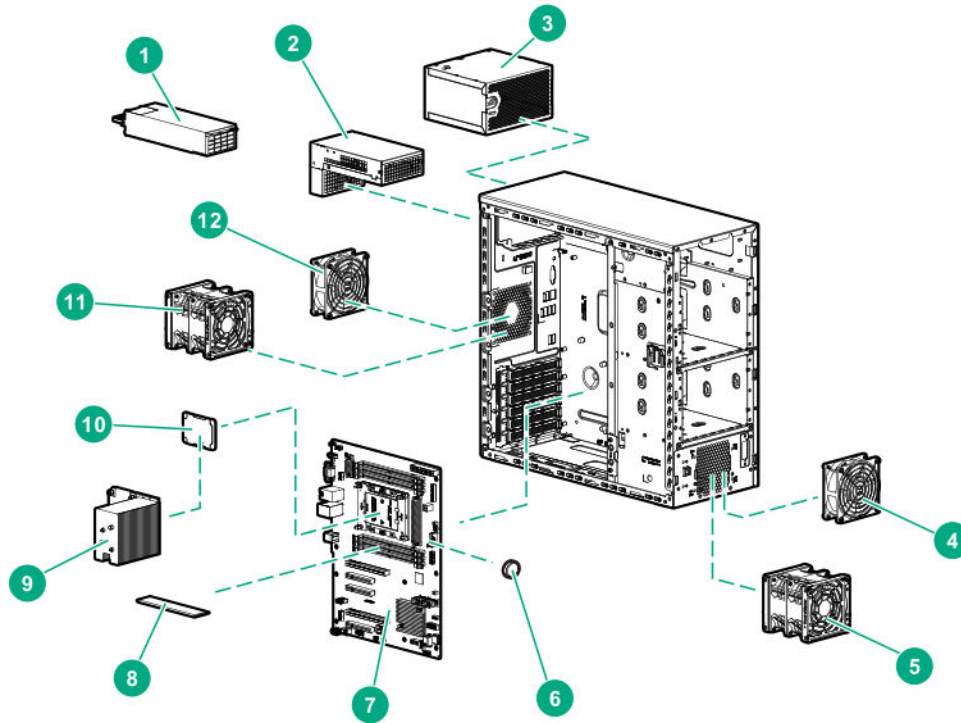

| Item | Description |
|------|---|
| 1 | <u>Hot-plug power supply spare part</u> |
| 2 | <u>Redundant power supply backplane module spare part</u> |
| 3 | <u>Non-hot-plug power supply spare part</u> |
| 4 | <u>PCIe fan spare part</u> |
| 5 | <u>Redundant PCIe fan module spare part ¹</u> |
| 6 | <u>System battery spare part</u> |
| 7 | <u>System board spare part</u> |
| 8 | <u>DIMM spare part</u> |
| 9 | <u>Heatsink spare part</u> |
| 10 | <u>Processor spare part</u> |
| 11 | <u>Redundant system fan spare part ¹</u> |
| 12 | <u>System fan spare part</u> |

¹ Same module is used for both system and PCIe redundant fan options.

Hot-plug power supply spare part

Customer self repair on page 7: Mandatory

| Description | Spare part number |
|---|-------------------|
| HPE 12V 800W Flexislot Platinum hot-plug power supply | 866730-001 |

Redundant power supply backplane spare part

Customer self repair on page 7: Mandatory

| Description | Spare part number |
|---|-------------------|
| Redundant power supply backplane module (includes cables) | 878925-001 |

Non-hot-plug power supply spare part

Customer self repair on page 7: Mandatory

| Description | Spare part number |
|--------------------|-------------------|
| 350 W power supply | 878924-001 |
| 550 W power supply | 878923-001 |

Redundant fan module spare part

Customer self repair on page 7: Mandatory

| Description | Spare part number |
|--|-------------------|
| Redundant fan module (system and PCIe) | 878927-001 |

System battery spare part

Customer self repair on page 7: Mandatory

| Description | Spare part number |
|---------------------------|-------------------|
| 3-V, lithium battery coin | 319603-001 |

System board assembly spare part

Customer self repair on page 7: Optional

| Description | Spare part number |
|-----------------------|-------------------|
| System board assembly | 878926-001 |

DIMM spare parts

Customer self repair on page 7: Mandatory

| Description | Spare part number |
|--|-------------------|
| 8 GB, single-rank x8 PC4-2666V-R Smart Memory | 850879-001 |
| 16 GB, single-rank x4 PC4-2666V-R Smart Memory | 850880-001 |
| 32 GB, dual-rank x4 PC4-2666V-R Smart Memory | 850881-001 |
| 8 GB, single-rank x8 PC4-2666V-R | 872969-001 |
| 16 GB, single-rank x4 PC4-2666V-R | 872970-001 |

Heatsink spare part

Customer self repair on page 7: No

| Description | Spare part number |
|-------------------|-------------------|
| Heatsink assembly | 878922-001 |

Processor spare parts

Customer self repair on page 7: No

| Description | Spare part number |
|--------------------------------------|-------------------|
| Intel Xeon-B 3104 processor assembly | 875709-001 |
| Intel Xeon-B 3106 processor assembly | 875710-001 |
| Intel Xeon-S 4108 processor assembly | 875712-001 |
| Intel Xeon-S 4110 processor assembly | 875711-001 |
| Intel Xeon-S 4112 processor assembly | 875714-001 |
| Intel Xeon-G 5120 processor assembly | 875718-001 |
| Intel Xeon-G 5122 processor assembly | 875719-001 |

PCIe fan module spare part

Customer self repair on page 7: Mandatory

| Description | Spare part number |
|-------------|-------------------|
| PCIe fan | 878929-001 |

System fan spare part

Customer self repair on page 7: Mandatory

| Description | Spare part number |
|-------------|-------------------|
| System fan | 878928-001 |

Server components

Hewlett Packard Enterprise continually improves and changes product parts. For complete and current supported spare parts information, see the Hewlett Packard Enterprise PartSurfer website:

<http://www.hpe.com/info/partssurfer>

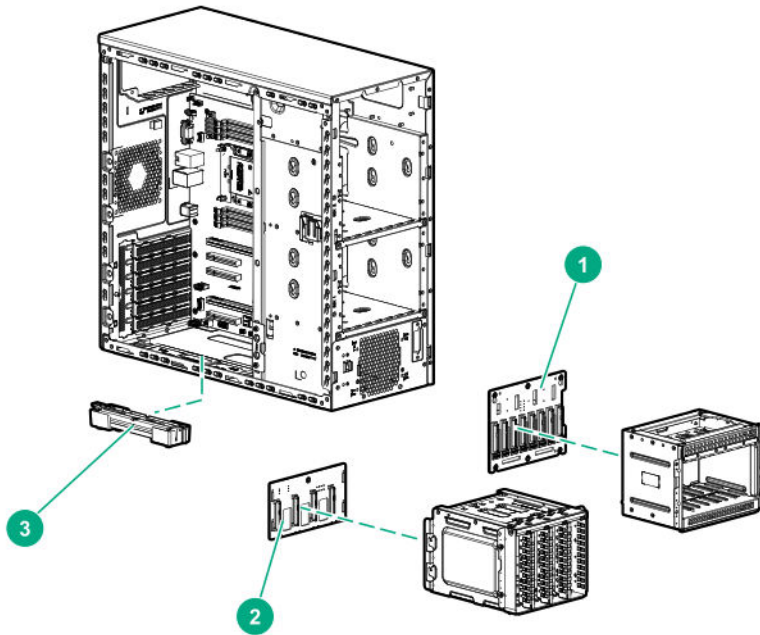

| Item | Description |
|------|---|
| 1 | <u>Eight-bay SFF drive cage assembly spare part</u> |
| 2 | <u>Four-bay LFF drive cage backplane spare part</u> |
| 3 | <u>Smart storage battery spare part</u> |
| 4 | <u>USB flash media device spare part</u> |
| 5 | <u>Cable spare parts*</u> |
| 6 | Trusted Platform Module spare part* |

* Not shown

Four-bay LFF drive cage backplane spare part

Customer self repair on page 7: Mandatory

| Description | Spare part number |
|-----------------------------------|-------------------|
| Four-bay LFF drive cage backplane | 878930-001 |

Eight-bay SFF drive cage assembly spare part

Customer self repair on page 7: Mandatory

| Description | Spare part number |
|------------------------------------|-------------------|
| Eight-bay SFF drive cage backplane | 792352-001 |

Smart storage battery spare part

Customer self repair on page 7: Mandatory

| Description | Spare part number |
|-----------------------|-------------------|
| Smart storage battery | 878644-001 |

USB flash media device spare part

Customer self repair on page 7: Mandatory

| Description | Spare part number |
|-------------------------|-------------------|
| 8 GB flash media device | 743503-001 |

Cable spare parts

Customer self repair on page 7: Mandatory

| Description | Spare part number |
|---|-------------------|
| Front panel LED cable assembly | 878931-001 |
| Front USB 3.0 ports cable assembly | 878932-001 |
| iLO service port cable assembly | 878933-001 |
| Serial port cable | 875571-001 |
| Hot-plug four-bay LFF/SFF drive mini SAS cable ¹ | 878327-001 |
| Non-hot-plug SATA to mini SAS cable (340 mm) | 878934-001 |
| Optical disc drive power SATA Y cable (600 mm/ 290 mm) | 878935-001 |

¹ Same cable is used for system board and PCIe card.

HPE Trusted Platform Module 2.0 spare part

Customer self repair on page 7: No

| Description | Spare part number |
|--|--------------------------|
| HPE Trusted Platform Module Gen10, TAA | 872159-001 |

Removal and replacement procedures

This chapter provides detailed instructions on how to remove and replace component spare parts.

Safety considerations

Before performing service procedures, review all the safety information.

Electrostatic discharge

Preventing electrostatic discharge

To prevent damaging the system, be aware of the precautions you must follow when setting up the system or handling parts. A discharge of static electricity from a finger or other conductor may damage system boards or other static-sensitive devices. This type of damage may reduce the life expectancy of the device.

Procedure

- Avoid hand contact by transporting and storing products in static-safe containers.
- Keep electrostatic-sensitive parts in their containers until they arrive at static-free workstations.
- Place parts on a grounded surface before removing them from their containers.
- Avoid touching pins, leads, or circuitry.
- Always be properly grounded when touching a static-sensitive component or assembly.

Grounding methods to prevent electrostatic discharge

Several methods are used for grounding. Use one or more of the following methods when handling or installing electrostatic-sensitive parts:

- Use a wrist strap connected by a ground cord to a grounded workstation or computer chassis. Wrist straps are flexible straps with a minimum of 1 megohm ± 10 percent resistance in the ground cords. To provide proper ground, wear the strap snug against the skin.
- Use heel straps, toe straps, or boot straps at standing workstations. Wear the straps on both feet when standing on conductive floors or dissipating floor mats.
- Use conductive field service tools.
- Use a portable field service kit with a folding static-dissipating work mat.

If you do not have any of the suggested equipment for proper grounding, have an authorized reseller install the part.

For more information on static electricity or assistance with product installation, contact an authorized reseller.

Symbols on equipment

The following symbols might be found on the equipment to indicate the presence of potentially hazardous conditions.

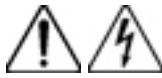

This symbol indicates the presence of hazardous energy circuits or electric shock hazards. Refer all servicing to qualified personnel.

WARNING: To reduce the risk of injury from electric shock hazards, do not open this enclosure. Refer all maintenance, upgrades, and servicing to qualified personnel.



This symbol indicates the presence of electric shock hazards. The area contains no user or field serviceable parts. Do not open for any reason.

WARNING: To reduce the risk of injury from electric shock hazards, do not open this enclosure.



This symbol on an RJ-45 receptacle indicates a network interface connection.

WARNING: To reduce the risk of electric shock, fire, or damage to the equipment, do not plug telephone or telecommunications connectors into this receptacle.

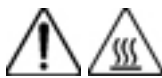

This symbol indicates the presence of a hot surface or hot component. If this surface is contacted, the potential for injury exists.

WARNING: To reduce the risk of injury from a hot component, allow the surface to cool before touching.



This symbol indicates that the component exceeds the recommended weight for one individual to handle safely.

WARNING: To reduce the risk of personal injury or damage to the equipment, observe local occupational health and safety requirements and guidelines for manual material handling.



These symbols, on power supplies or systems, indicate that the equipment is supplied by multiple sources of power.

WARNING: To reduce the risk of injury from electric shock, remove all power cords to disconnect power from the system completely.

Server warnings and cautions



WARNING:

To reduce the risk of personal injury, electric shock, or damage to the equipment, disconnect the power cord to remove power from the server. Pressing the Power On/Standby button does not shut off system power completely. Portions of the power supply and some internal circuitry remain active until AC power is removed.



WARNING:

To reduce the risk of personal injury from hot surfaces, allow the drives and the internal system components to cool before touching them.

⚠ CAUTION:

Protect the server from power fluctuations and temporary interruptions with a regulating UPS. This device protects the hardware from damage caused by power surges and voltage spikes and keeps the server in operation during a power failure.

⚠ CAUTION:

To prevent improper cooling and thermal damage, do not operate the server with the media bay blank, chassis cover, or the front bezel removed.

⚠ CAUTION:

To prevent damage to electrical components, properly ground the server before beginning any installation procedure. Improper grounding can cause electrostatic discharge.

⚠ CAUTION:

To avoid data loss, Hewlett Packard Enterprise recommends that you back up all server data before installing or removing a hardware option, or performing a server maintenance or troubleshooting procedure.

Required tools

You need the following items for some procedures:

- T-10 Torx screwdriver
- T-15 Torx screwdriver

Preparation procedures

To access some components and perform certain service procedures, you must perform one or more of the following procedures:

Procedure

- **Power down the server** on page 27
 - **Remove the server from the rack** on page 28
-

NOTE:

To install the server to the rack, reverse the removal procedure and place the server at the center of the tray after installation.

- **Remove the access panel** on page 29
- **Remove the front bezel** on page 31

Power down the server

Before powering down the server for any upgrade or maintenance procedures, perform a backup of critical server data and programs.

 **IMPORTANT:**

When the server is in standby mode, auxiliary power is still being provided to the system.

To power down the server, use one of the following methods:

- Press and release the Power On/Standby button.
This method initiates a controlled shutdown of applications and the OS before the server enters standby mode.
- Press and hold the Power On/Standby button for more than 4 seconds to force the server to enter standby mode.
This method forces the server to enter standby mode without properly exiting applications and the OS. If an application stops responding, you can use this method to force a shutdown.
- Use a virtual power button selection through iLO.
This method initiates a controlled remote shutdown of applications and the OS before the server enters standby mode.

Before proceeding, verify that the server is in standby mode by observing that the system power LED is amber.

Remove the server from the rack

 **WARNING:**

This server is heavy. To reduce the risk of personal injury or damage to the equipment:

- Observe local occupational health and safety requirements and guidelines for manual material handling.
 - Get help to lift and stabilize the product during installation or removal, especially when the product is not fastened to the rails. Hewlett Packard Enterprise recommends that a minimum of two people are required for all rack server installations. A third person may be required to help align the server if the server is installed higher than chest level.
 - Use caution when installing the server in or removing the server from the rack; it is unstable when not fastened to the rails.
-

Prerequisites

Before you perform this procedure, make sure that you have T-15 Torx screwdriver available.

Procedure

1. **Power down the server** on page 27.
2. Fully extend the server out of the rack.

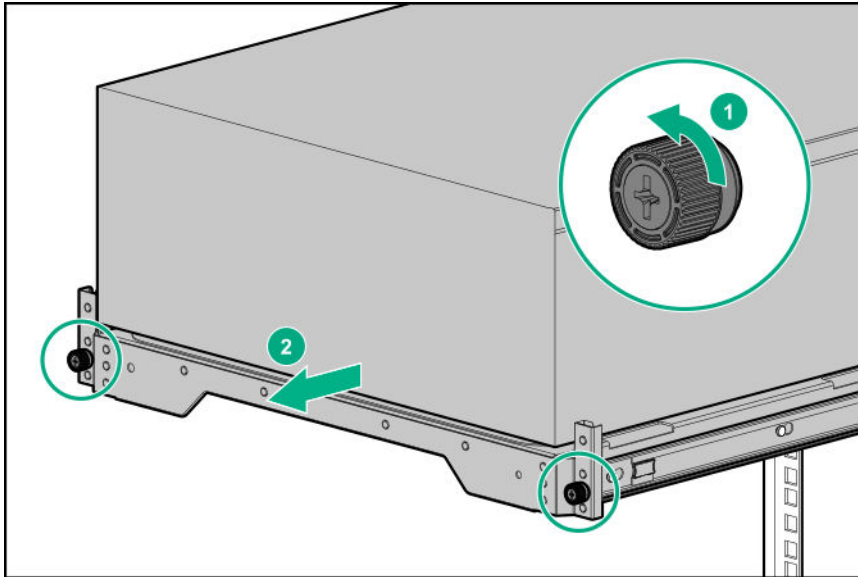

3. Disconnect all peripheral cables from the server.
4. Disconnect each power cord from the server.
5. Lift the server from the tray.

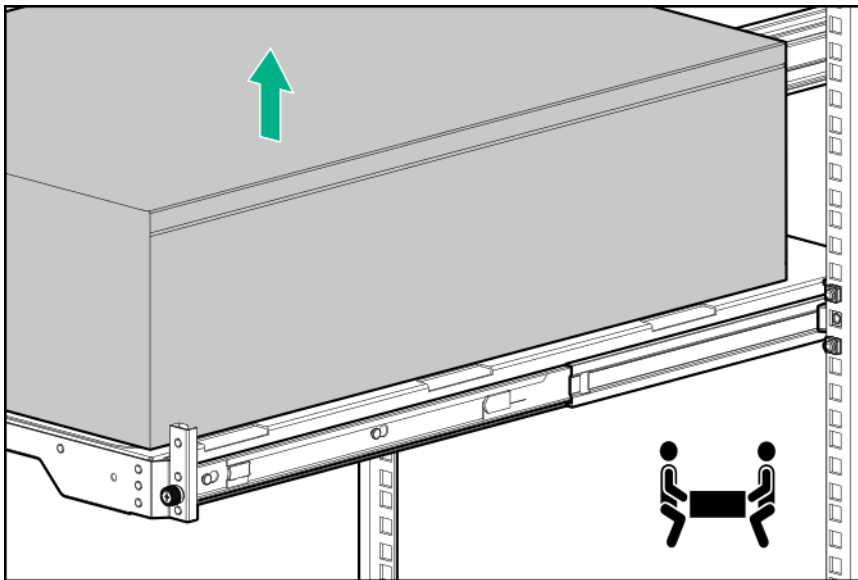

6. Place the server on a sturdy, level surface.

Remove the access panel



WARNING:

To reduce the risk of personal injury from hot surfaces, allow the drives and the internal system components to cool before touching them.



CAUTION:

For proper cooling, do not operate the server without the access panel, baffles, expansion slot covers, or blanks installed. If the server supports hot-plug components, minimize the amount of time the access panel is open.

**CAUTION:**

To prevent damage to electrical components, properly ground the server before beginning any installation procedure. Improper grounding can cause electrostatic discharge.

Procedure

1. **Power down the server** on page 27.
2. Remove all power:
 - a. Disconnect each power cord from the power source.
 - b. Disconnect each power cord from the server.
3. Do one of the following:
 - Server in rack mode: **Remove the server from the rack** on page 28.
 - Server in tower mode: Place the server on its side and access panel facing up.
4. If a Kensington security cable is installed, disconnect it from the rear panel. See the security cable documentation for instructions.
5. Place the server on its side and access panel facing up.
6. Remove the access panel:
 - a. Loosen the access panel thumbscrews.
 - b. Slide and remove the access panel from the server.

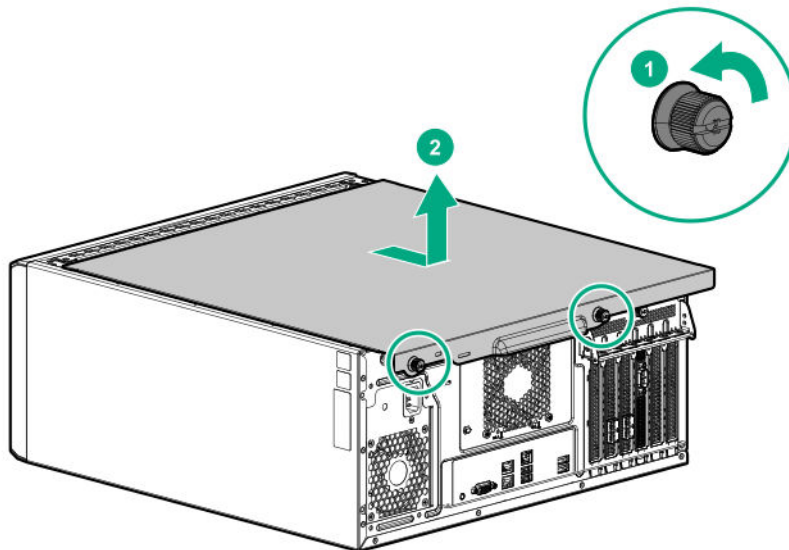

Remove the front bezel

Procedure

1. If the bezel is locked, **power down the server**.
2. Remove all power:
 - a. Disconnect each power cord from the power source.
 - b. Disconnect each power cord from the server.
3. Place the server on its side and access panel facing up.
4. If the front bezel is locked by the internal locker, **remove the access panel**.
5. Open and remove the front bezel:
 - a. Slide up the internal locker.
 - b. Open the front bezel.
 - c. Remove the front bezel.

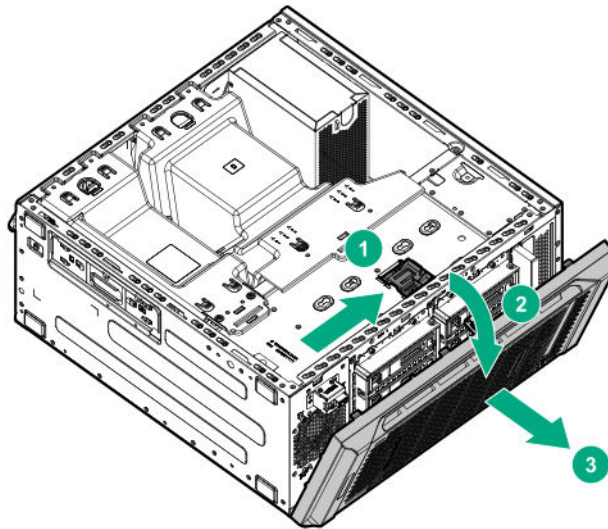

Remove the PCIe air baffle

Procedure

1. **Power down the server** on page 27.
2. Remove all power:
 - a. Disconnect each power cord from the power source.
 - b. Disconnect each power cord from the server.
3. Do one of the following:

- Server in rack mode: **Remove the server from the rack** on page 28.
 - Server in tower mode: Place the server on its side and access panel facing up.
4. **Remove the access panel** on page 29.
 5. Remove the PCIe air baffle.

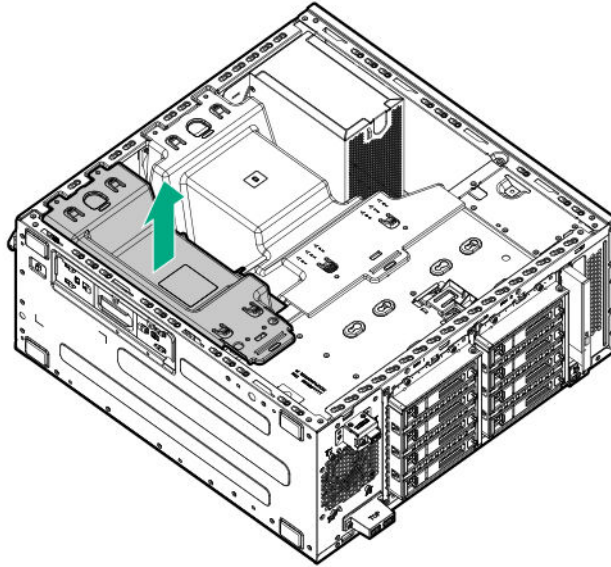

Remove the system air baffle

Procedure

1. **Power down the server** on page 27.
2. Remove all power:
 - a. Disconnect each power cord from the power source.
 - b. Disconnect each power cord from the server.
3. Do one of the following:
 - Server in rack mode: **Remove the server from the rack** on page 28.
 - Server in tower mode: Place the server on its side and access panel facing up.
4. **Remove the access panel** on page 29.
5. **Remove the PCIe air baffle** on page 31.
6. Remove the system air baffle.

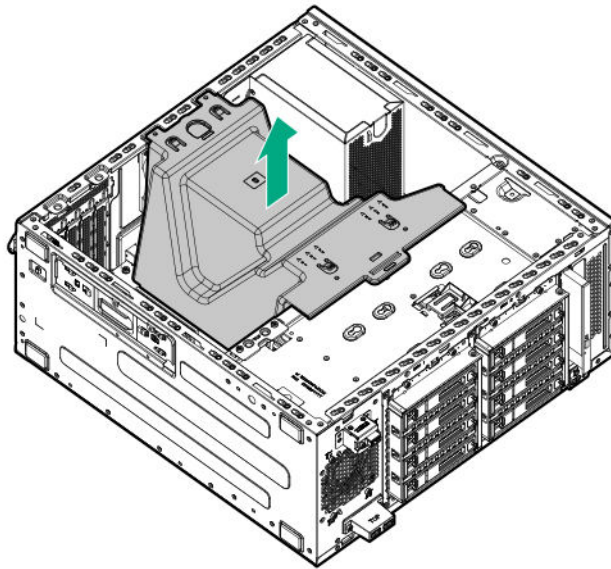

Removing and replacing a drive blank

- ⚠ CAUTION:**
To prevent improper cooling and thermal damage, do not operate the server unless all bays are populated with either a component or a blank.

Removing and replacing an LFF drive blank

Procedure

1. **Remove the front bezel** on page 31.
2. Remove the drive blank.

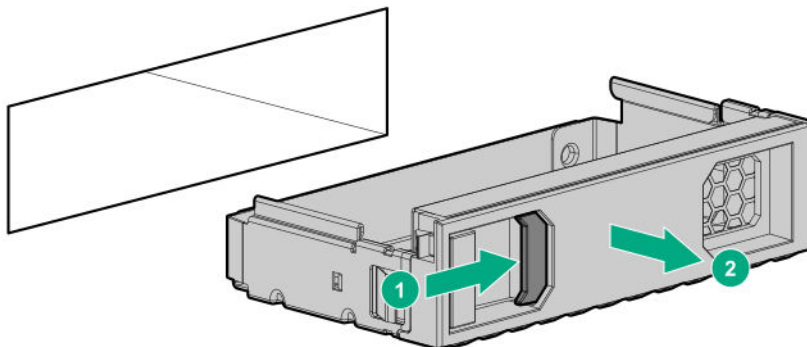

3. To replace the blank, slide the blank into the bay until it locks into place.

Removing and replacing an SFF drive blank

Procedure

1. **Remove the front bezel** on page 31.
2. Remove the drive blank.

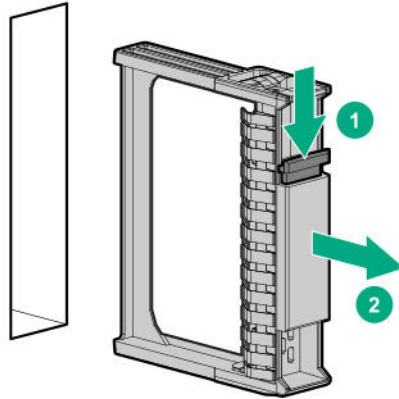

3. To replace the blank, slide the blank into the bay until it locks into place.

Removing and replacing drives

Removing and replacing the hot-plug drive

⚠ CAUTION:
To prevent improper cooling and thermal damage, do not operate the server unless all bays are populated with either a component or a blank.

Procedure

1. **Remove the front bezel** on page 31.
2. Back up all server data on the drive.
3. **Determine the status of the drive from the drive LED definitions.**
4. Remove the drive.

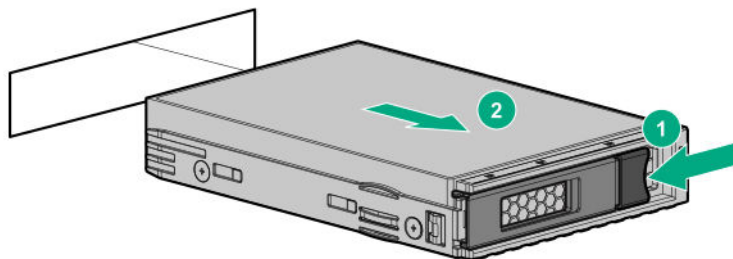

To replace the component, reverse the removal procedure.

Removing and replacing the non-hot-plug drive

Prerequisites

Before you perform this procedure, make sure you have the T-15 Torx Screwdriver available.

Procedure

1. **Power down the server** on page 27.
2. Remove all power:
 - a. Disconnect each power cord from the power source.
 - b. Disconnect each power cord from the server.
3. Do one of the following:
 - Server in rack mode: **Remove the server from the rack** on page 28.
 - Server in tower mode: Place the server on its side and access panel facing up.
4. **Remove the access panel** on page 29.
5. **Remove the front bezel** on page 31.
6. **Remove the PCIe air baffle** on page 31.
7. **Remove the system air baffle** on page 32.
8. Disconnect all existing drive cables.
9. **Remove the non-hot-plug drive cage.**
10. Remove the non-hot-plug drive.

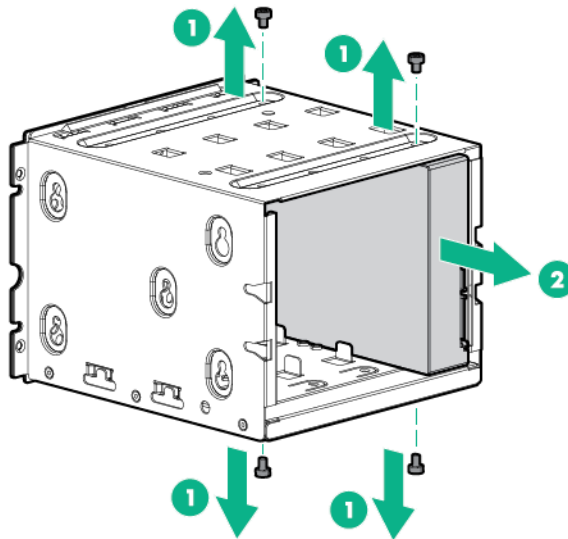

To replace the component, reverse the removal procedure.

Replacing the front panel LEDs cable assembly

Prerequisites

Before you perform this procedure, make sure that you have a T-15 Torx screwdriver available.

Procedure

1. **Power down the server** on page 27.
2. Remove all power:
 - a. Disconnect each power cord from the power source.
 - b. Disconnect each power cord from the server.
3. Do one of the following:
 - Server in rack mode: **Remove the server from the rack** on page 28.
 - Server in tower mode: Place the server on its side and access panel facing up.
4. **Remove the access panel** on page 29.
5. **Remove the front bezel** on page 31.
6. **Remove the PCIe air baffle** on page 31.
7. **Remove the system air baffle** on page 32.
8. Disconnect the front I/O cable from the system board. (**System board components** on page 73)
9. Remove the T-15 screw which secures the front panel LED module to the front panel.
10. Pull the front panel LED module away from the front panel.

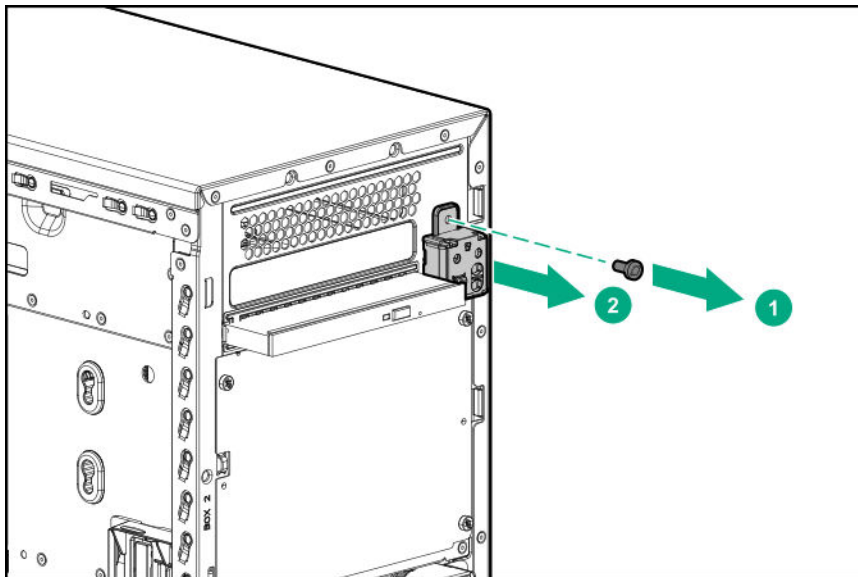

To replace the component, reverse the removal procedure.

Replacing the front panel USB ports cable assembly

Prerequisites

Before you perform this procedure, make sure that you have a T-15 Torx screwdriver available.

Procedure

1. **Power down the server** on page 27.
2. Remove all power:
 - a. Disconnect each power cord from the power source.
 - b. Disconnect each power cord from the server.
3. Do one of the following:
 - Server in rack mode: **Remove the server from the rack** on page 28.
 - Server in tower mode: Place the server on its side and access panel facing up.
4. **Remove the access panel** on page 29.
5. **Remove the front bezel** on page 31.
6. **Remove the PCIe air baffle** on page 31.
7. **Remove the system air baffle** on page 32.
8. Disconnect the front USB 3.0 ports cable from the system board. (**System board components** on page 73)
 - a. Press the latch on the connector.
 - b. Pull out the cable from the connector, to avoid damaging the connector by pulling up the cable vertically.
 - c. Release the cable secured in the cable clip on the chassis.
9. Remove two T-15 screws which secure the front panel USB ports module to the front panel.
10. Pull the front panel USB ports module away from the front panel.

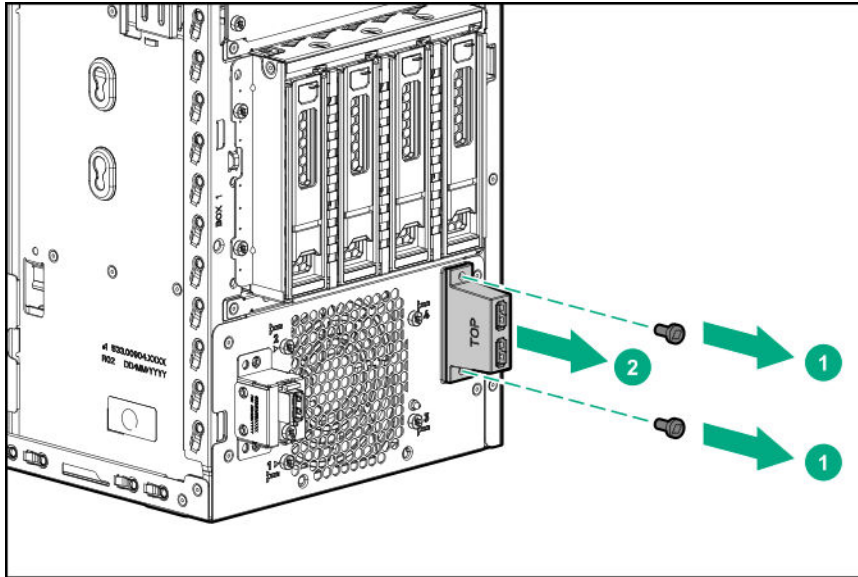

To replace the component, reverse the removal procedure.

Replacing the iLO service port cable assembly

Prerequisites

Before you perform this procedure, make sure that you have a T-15 Torx screwdriver available.

Procedure

1. **Power down the server** on page 27.
2. Remove all power:
 - a. Disconnect each power cord from the power source.
 - b. Disconnect each power cord from the server.
3. Do one of the following:
 - Server in rack mode: **Remove the server from the rack** on page 28.
 - Server in tower mode: Place the server on its side and access panel facing up.
4. **Remove the access panel** on page 29.
5. **Remove the front bezel** on page 31.
6. **Remove the PCIe air baffle** on page 31.
7. **Remove the system air baffle** on page 32.
8. Disconnect the front iLO service port cable from the system board. (**System board components** on page 73)
9. Remove the T-15 screws which secure the front panel iLO USB module to the front panel.
10. Release the cable secured in the cable clip on the chassis.
11. Pull the iLO service port assembly away from the front panel.

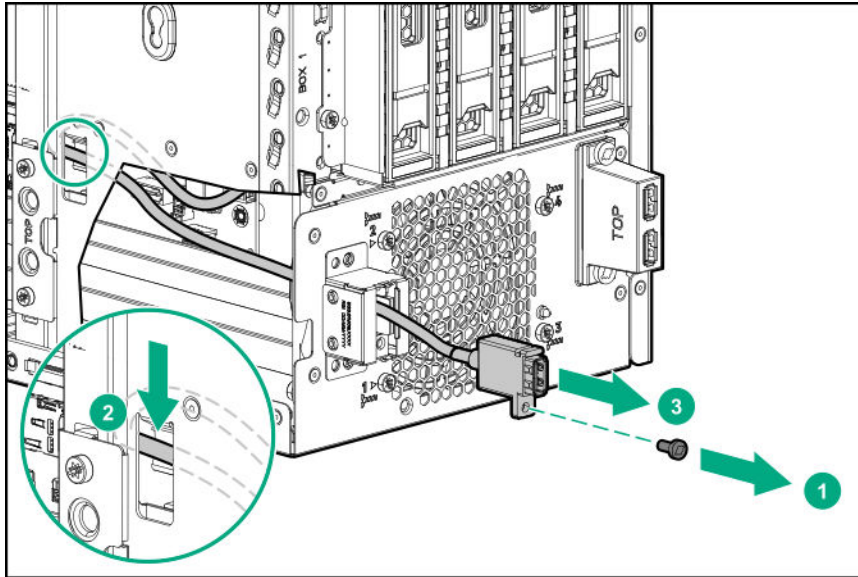

To replace the component, reverse the removal procedure.

Replacing the serial port cable

Procedure

1. **Power down the server** on page 27.
2. Remove all power:
 - a. Disconnect each power cord from the power source.
 - b. Disconnect each power cord from the server.
3. Do one of the following:
 - Server in rack mode: **Remove the server from the rack** on page 28.
 - Server in tower mode: Place the server on its side and access panel facing up.
4. **Remove the access panel** on page 29.
5. **Remove the PCIe air baffle** on page 31.
6. **Remove the system air baffle** on page 32.
7. Loosen the thumbscrew and open the slot cover retainer.
8. Disconnect the serial cable from the system board and remove the serial port assembly.

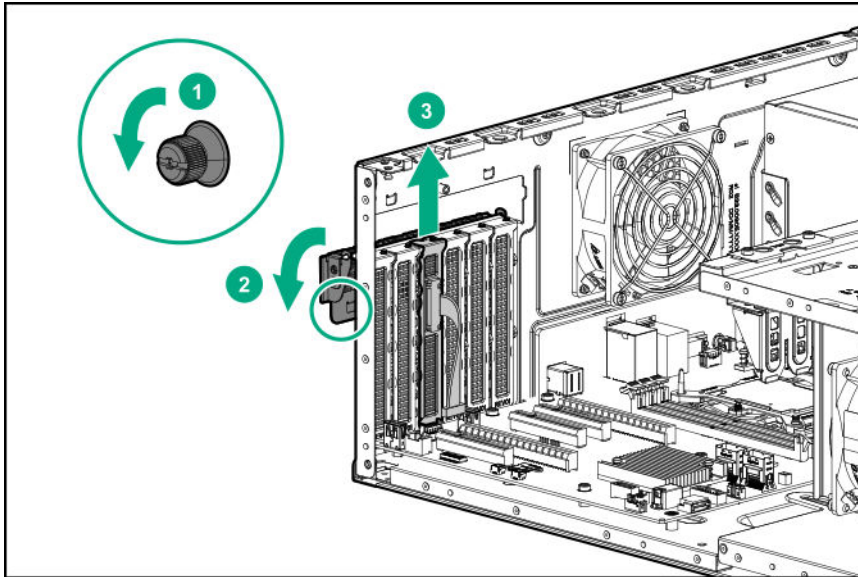

9. Remove the failed serial port from the bracket:
 - a. Loosen the two nut screws securing the serial port.
 - b. Detach the serial cable from the bracket.

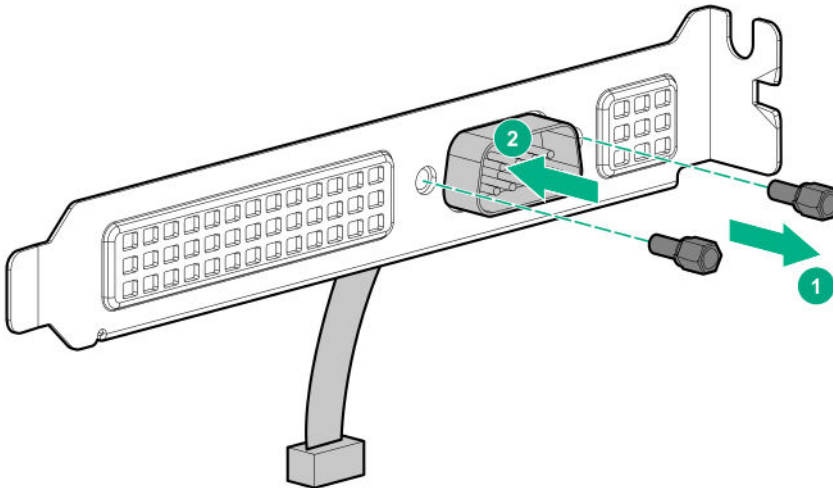

To replace the component, reverse the removal procedure.

Replacing the DIMM

ⓘ IMPORTANT:

Before replacing a DIMM, expansion board, or any other circuit board component due to a perceived hardware error, verify that the component is firmly seated in the slot. Do not bend or flex circuit boards when reseating components.

Procedure

1. **Power down the server** on page 27.
2. Remove all power:
 - a. Disconnect each power cord from the power source.
 - b. Disconnect each power cord from the server.
3. Do one of the following:
 - Server in rack mode: **Remove the server from the rack** on page 28.
 - Server in tower mode: Place the server on its side and access panel facing up.
4. **Remove the access panel** on page 29.
5. **Remove the PCIe air baffle** on page 31.
6. **Remove the system air baffle** on page 32.
7. Remove the DIMM.

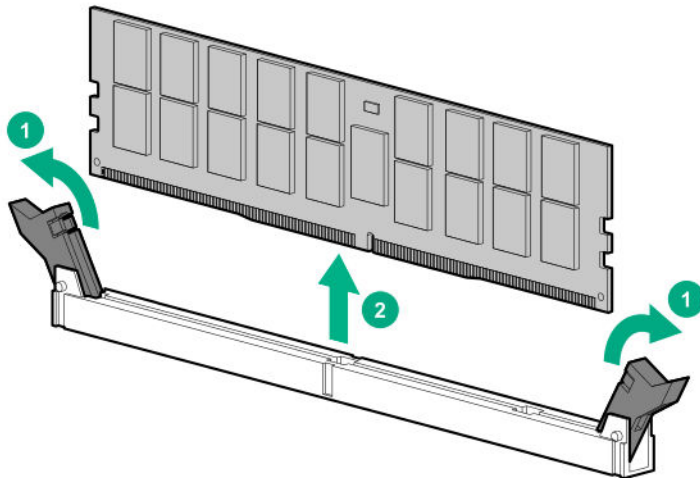

To replace the component, reverse the removal procedure.

Replacing the optical disc drive

Procedure

1. **Power down the server** on page 27.
2. Remove all power:
 - a. Disconnect each power cord from the power source.
 - b. Disconnect each power cord from the server.
3. Do one of the following:

- Server in rack mode: **Remove the server from the rack** on page 28.
 - Server in tower mode: Place the server on its side and access panel facing up.
4. **Remove the access panel** on page 29.
 5. **Remove the system air baffle** on page 32.
 6. **Remove the PCIe air baffle.**
 7. Disconnect the power and the SATA Y cable from the optical disc drive.
 8. **Release cables from clip and metal tabs.**
 9. Press the metal tab and then remove the optical disc drive.

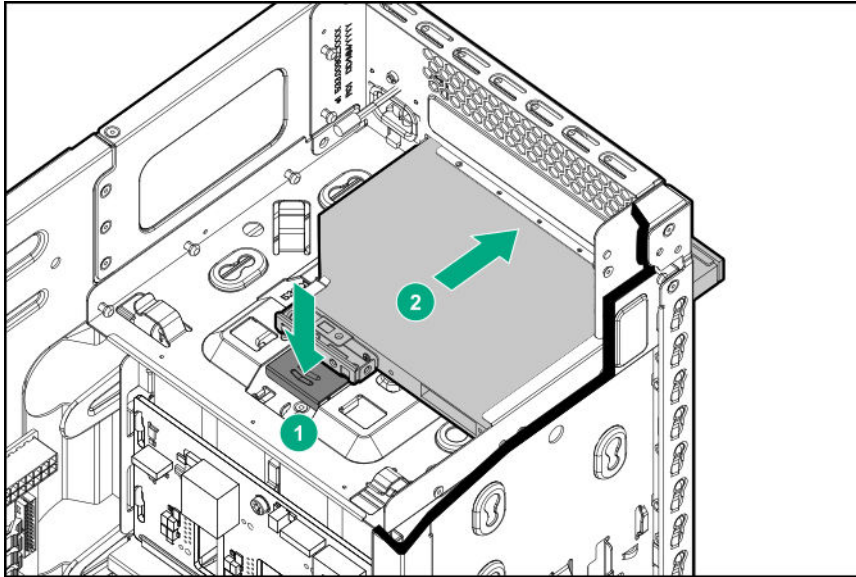

To replace the component, reverse the removal procedure.

Replacing the four-LFF non-hot-plug drive cage

⚠ CAUTION:

To prevent improper cooling and thermal damage, do not operate the enclosure unless all device bays are populated with either a component or a blank.

Prerequisites

Before you perform this procedure, make sure that you have the T-15 Torx Screwdriver available.

Procedure

1. **Power down the server** on page 27.
2. Remove all power:
 - a. Disconnect each power cord from the power source.
 - b. Disconnect each power cord from the server.
3. Do one of the following:

- Server in rack mode: **Remove the server from the rack** on page 28.
- Server in tower mode: Place the server on its side and access panel facing up.

4. **Remove the access panel** on page 29.
5. **Remove the front bezel** on page 31.
6. **Remove the PCIe air baffle** on page 31.
7. **Remove the system air baffle** on page 32.
8. Disconnect all existing drive cables.
9. Remove the non-hot-plug drive cage.

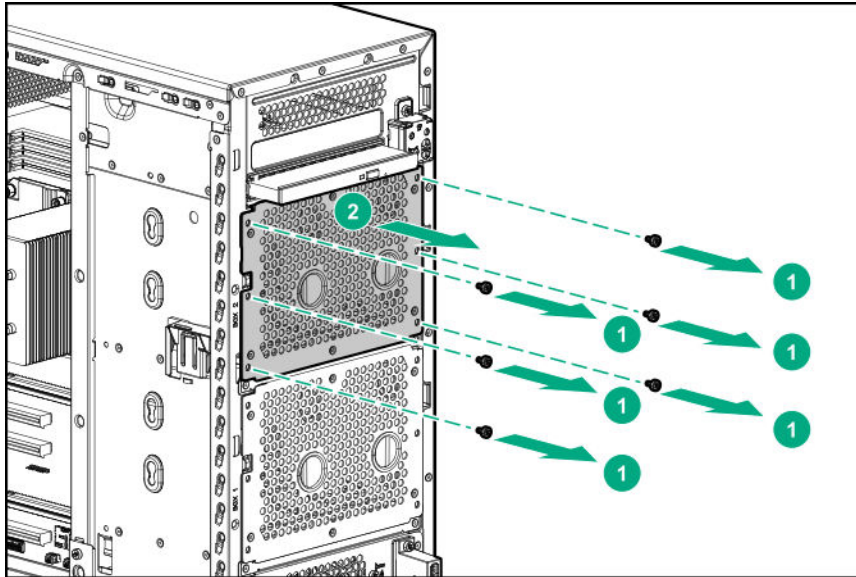

10. **Remove the non-hot-plug drives.**

To replace the component, reverse the removal procedure.

Replacing the four-LFF drive backplane

Prerequisites

Before you perform this procedure, make sure that you have T-15 Torx screwdriver available.

Procedure

1. **Power down the server** on page 27.
2. Remove all power:
 - a. Disconnect each power cord from the power source.
 - b. Disconnect each power cord from the server.
3. Do one of the following:

- Server in rack mode: **Remove the server from the rack** on page 28.
- Server in tower mode: Place the server on its side and access panel facing up.

4. **Remove the access panel** on page 29.
5. **Remove the front bezel** on page 31.
6. **Remove the PCIe air baffle** on page 31.
7. **Remove the system air baffle** on page 32.
8. Disconnect all existing drive cables from the drive backplane.
9. Remove all **drives** and **drive blanks**. Note where each drive is located.
10. Remove the drive cage.

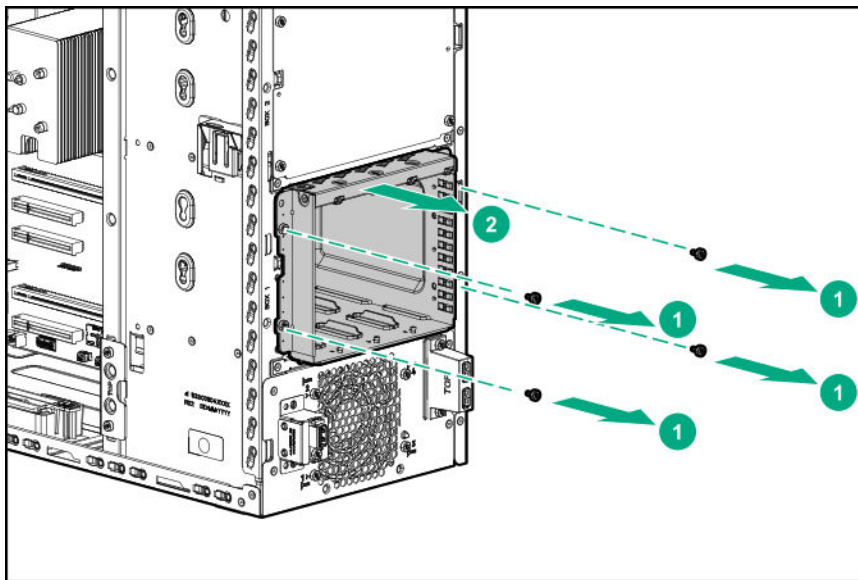

11. Remove the drive backplane.

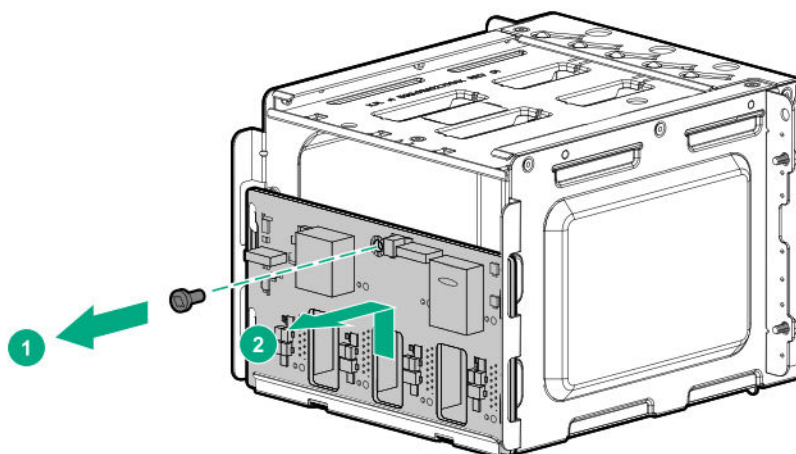

To replace the component, reverse the removal procedure.

Replacing the eight-SFF drive cage assembly

Prerequisites

Before you perform this procedure, make sure that you have T-15 Torx screwdriver available.

Procedure

1. **Power down the server** on page 27.
2. Remove all power:
 - a. Disconnect each power cord from the power source.
 - b. Disconnect each power cord from the server.
3. Do one of the following:
 - Server in rack mode: **Remove the server from the rack** on page 28.
 - Server in tower mode: Place the server on its side and access panel facing up.
4. **Remove the access panel** on page 29.
5. **Remove the front bezel** on page 31.
6. **Remove the PCIe air baffle** on page 31.
7. **Remove the system air baffle** on page 32.
8. Disconnect all existing drive cables.
9. Remove all **drives** and **drive blanks**. Note where each drive is located.
10. Remove the drive cage assembly.

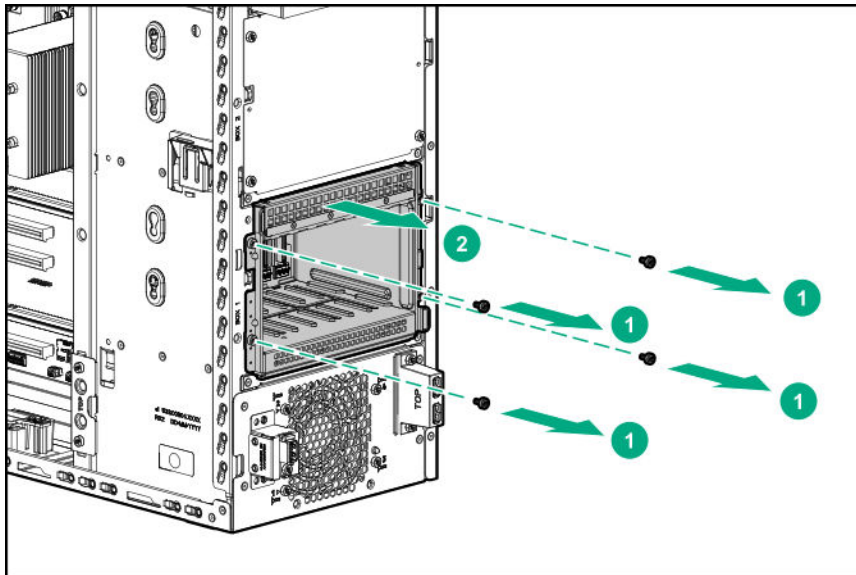

To replace the component, reverse the removal procedure.

Replacing the M.2 SSD

Prerequisites

Before you perform this procedure, make sure that you have Philips No 1 screwdriver available.

Procedure

1. **Power down the server** on page 27.
2. Remove all power:
 - a. Disconnect each power cord from the power source.
 - b. Disconnect each power cord from the server.
3. Do one of the following:
 - Server in rack mode: **Remove the server from the rack** on page 28.
 - Server in tower mode: Place the server on its side and access panel facing up.
4. **Remove the access panel** on page 29.
5. **Remove the PCIe air baffle** on page 31.
6. **Remove the system air baffle** on page 32.
7. Disconnect the SATA cable.
8. Remove the M.2 SSD enablement board.

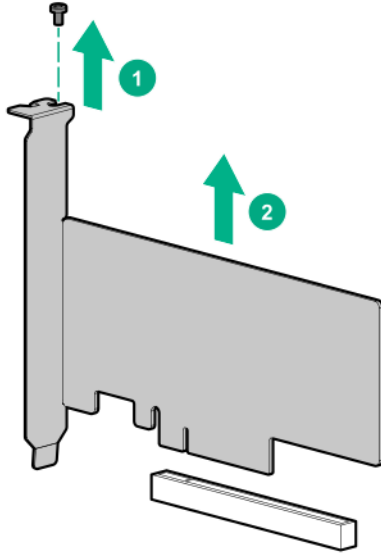

9. Remove the M.2 SSD.

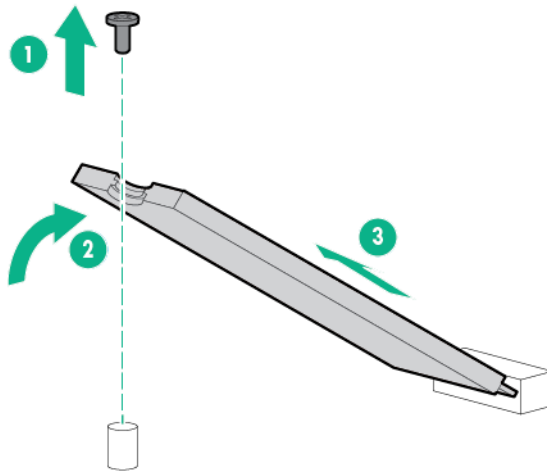

To replace the component, reverse the removal procedure.

Replacing the GPU

Prerequisites

Before performing this procedure, make sure you have the T-15 Torx screwdriver available.

Procedure

1. **Power down the server** on page 27.
2. Remove all power:
 - a. Disconnect each power cord from the power source.
 - b. Disconnect each power cord from the server.
3. Do one of the following:
 - Server in rack mode: **Remove the server from the rack** on page 28.
 - Server in tower mode: Place the server on its side and access panel facing up.
4. **Remove the access panel** on page 29.
5. **Remove the PCIe air baffle** on page 31.
6. **Remove the system air baffle** on page 32.
7. Remove the GPU.

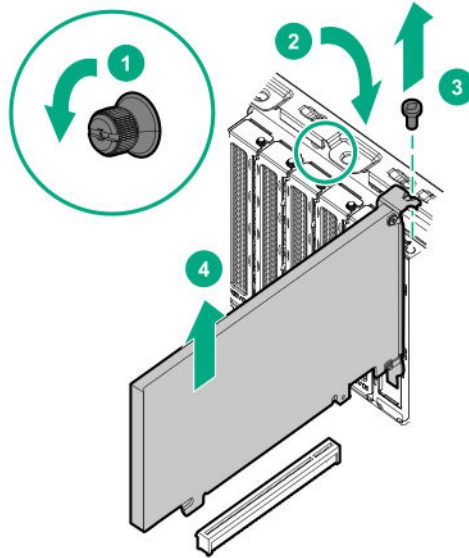

To replace the component, reverse the removal procedure.

Replacing the internal USB device

Procedure

1. **Power down the server** on page 27.
2. Remove all power:
 - a. Disconnect each power cord from the power source.
 - b. Disconnect each power cord from the server.
3. Do one of the following:
 - Server in rack mode: **Remove the server from the rack** on page 28.
 - Server in tower mode: Place the server on its side and access panel facing up.
4. **Remove the access panel** on page 29.
5. **Remove the PCIe air baffle** on page 31.
6. **Remove the system air baffle** on page 32.
7. Disconnect the USB device from the internal USB port.

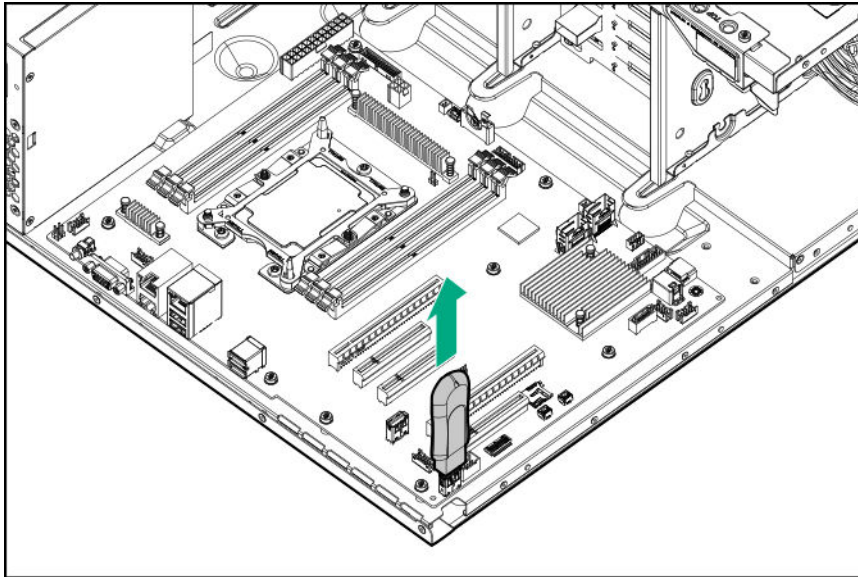

To replace the component, reverse the removal procedure.

Replacing the non-hot-plug power supply

Prerequisites

Before you perform this procedure, make sure that you have T-15 Torx screwdriver available.

Procedure

1. **Power down the server** on page 27.
2. Remove all power:
 - a. Disconnect each power cord from the power source.
 - b. Disconnect each power cord from the server.
3. Do one of the following:
 - Server in rack mode: **Remove the server from the rack** on page 28.
 - Server in tower mode: Place the server on its side and access panel facing up.
4. **Remove the access panel** on page 29.
5. **Remove the PCIe air baffle** on page 31.
6. **Remove the system air baffle** on page 32.
7. Disconnect all power supply cables from the system board, drive cages, and devices
8. Remove the power supply.

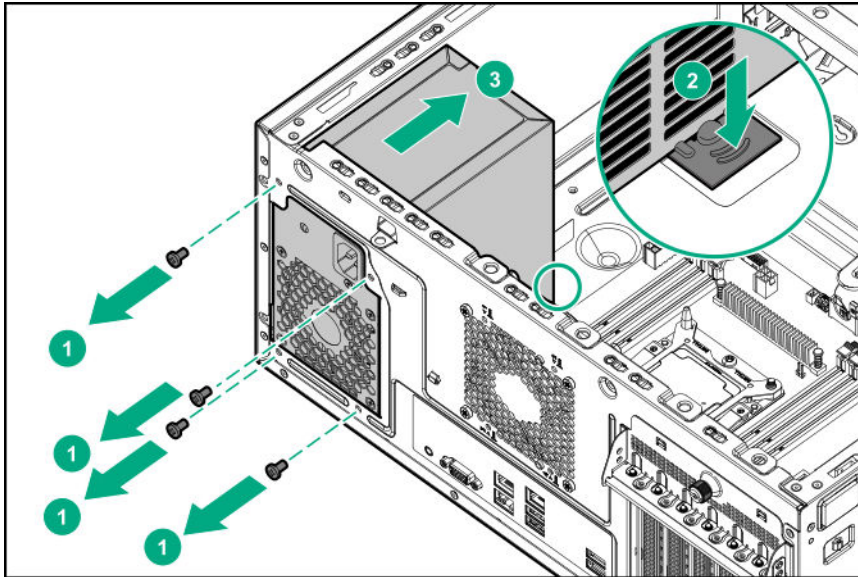

To replace the component, reverse the removal procedure.

Removing the power supply blank

- ⚠ CAUTION:**
To prevent improper cooling and thermal damage, do not operate the server unless all bays are populated with either a component or a blank.

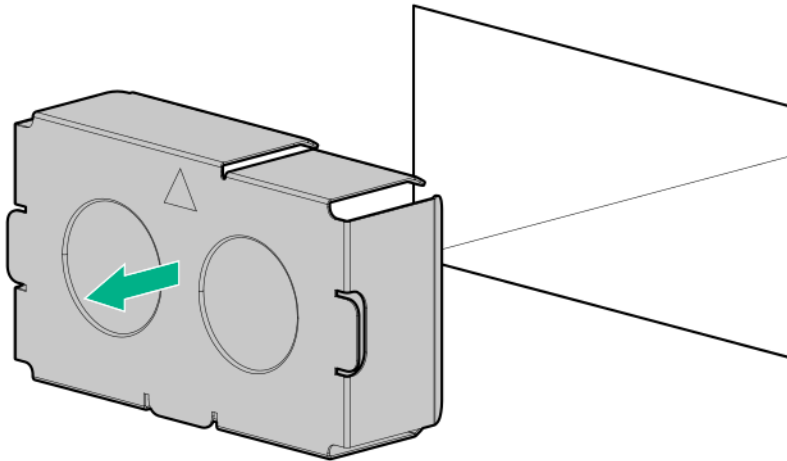

To replace the component, reverse the removal procedure.

Replacing the hot-plug power supply

Procedure

1. **Power down the server** on page 27.
2. Remove all power:

- a. Disconnect each power cord from the power source.
 - b. Disconnect each power cord from the server.
3. Release the strain relief strap.

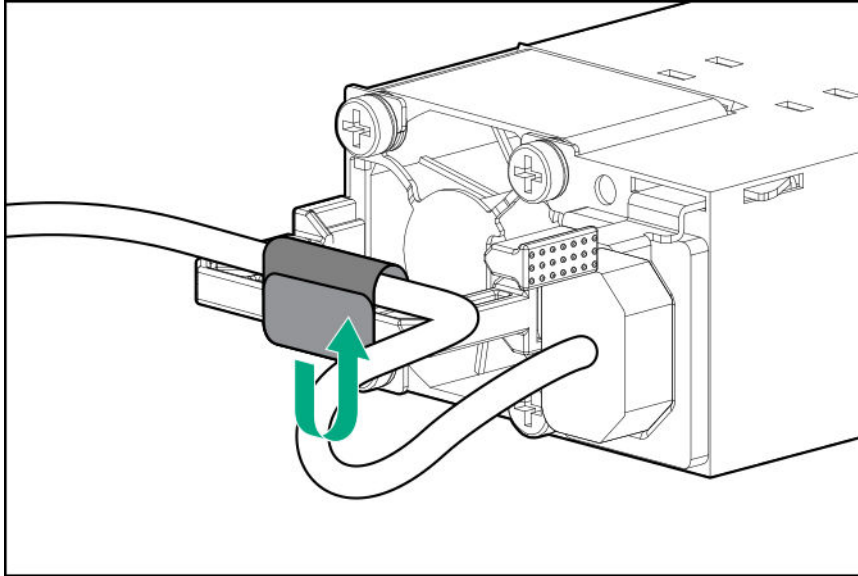

4. Remove the power supply.

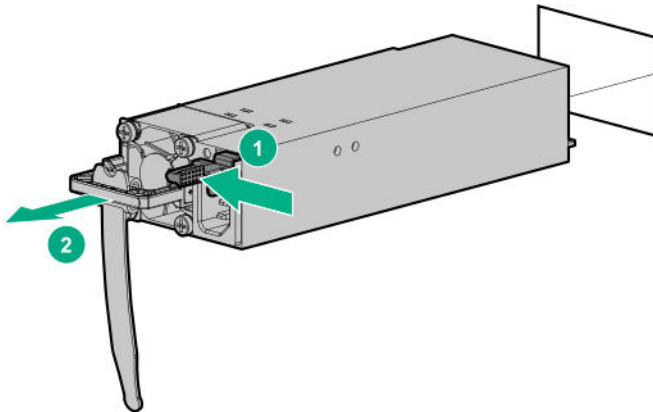

To replace the component, reverse the removal procedure.

Replacing the redundant power supply backplane module

Prerequisites

Before you perform this procedure, make sure that you have T-15 Torx screwdriver available.

Procedure

1. **Power down the server** on page 27.
2. Remove all power:

- a. Disconnect each power cord from the power source.
 - b. Disconnect each power cord from the server.
3. Do one of the following:
- Server in rack mode: **Remove the server from the rack** on page 28.
 - Server in tower mode: Place the server on its side and access panel facing up.
4. **Remove the access panel** on page 29.
5. **Remove the PCIe air baffle** on page 31.
6. **Remove the system air baffle** on page 32.
7. If installed, **remove the power input module**.
8. Disconnect all the backplane cables.
9. Remove the RPS backplane assembly from the bay.

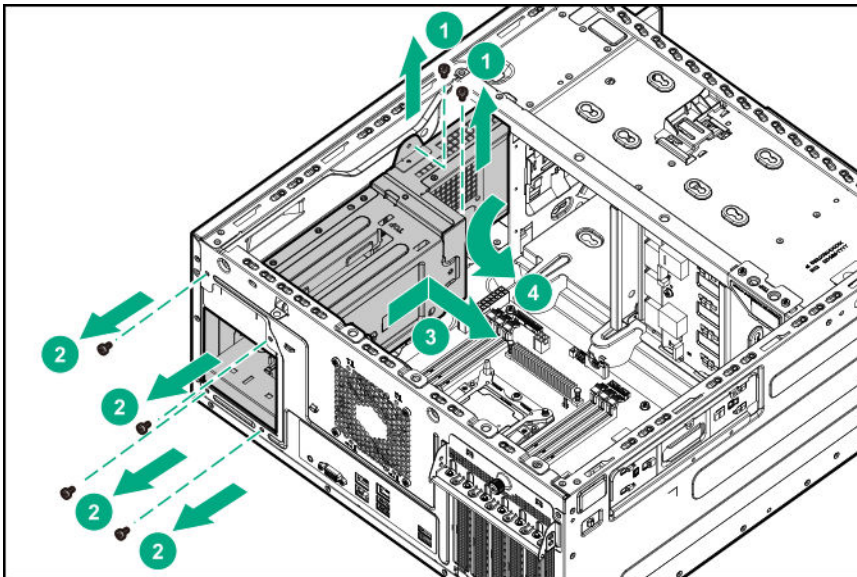

10. Detach the RPS bracket from the RPS backplane.

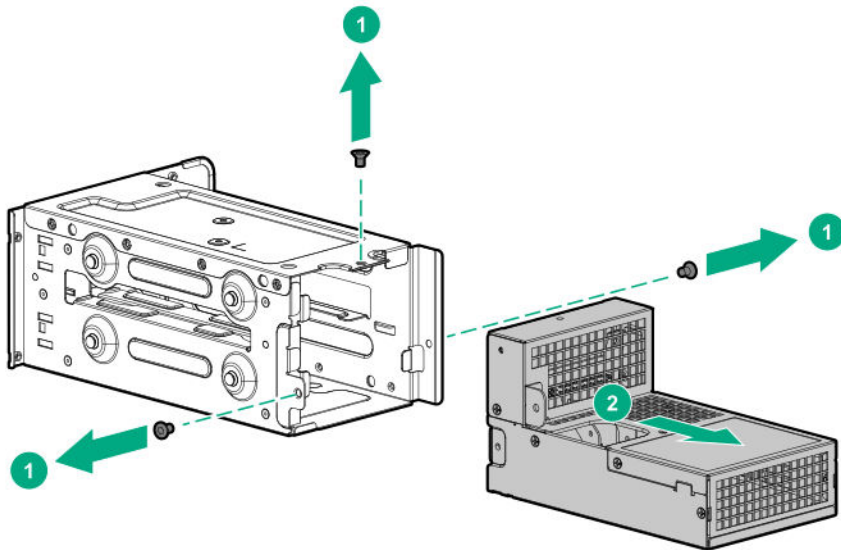

To replace the component, reverse the removal procedure.

Replacing fans

Replacing the PCIe fan module

Prerequisites

Before you perform this procedure, make sure that you have T-15 Torx screwdriver available.

Procedure

1. **Power down the server** on page 27.
2. Remove all power:
 - a. Disconnect each power cord from the power source.
 - b. Disconnect each power cord from the server.
3. Do one of the following:
 - Server in rack mode: **Remove the server from the rack** on page 28.
 - Server in tower mode: Place the server on its side and access panel facing up.
4. **Remove the access panel** on page 29.
5. **Remove the PCIe air baffle** on page 31.
6. **Remove the system air baffle** on page 32.
7. Disconnect all fan cables from the system board.
8. Remove the cables from the cable clip.
9. Remove the PCIe fan module.

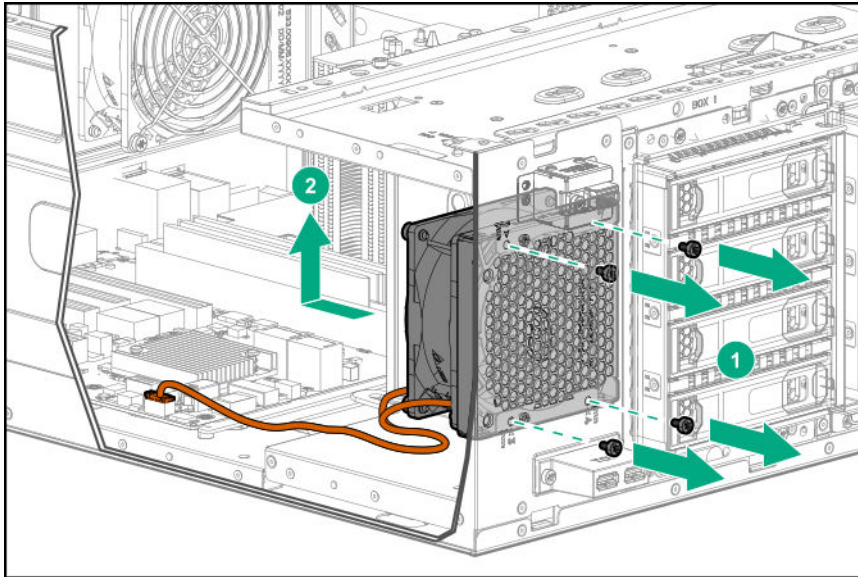

To replace the component, reverse the removal procedure.

Replacing the system fan module

Prerequisites

Before you perform this procedure, make sure that you have T-15 Torx screwdriver available.

Procedure

1. **Power down the server** on page 27.
2. Remove all power:
 - a. Disconnect each power cord from the power source.
 - b. Disconnect each power cord from the server.
3. Do one of the following:
 - Server in rack mode: **Remove the server from the rack** on page 28.
 - Server in tower mode: Place the server on its side and access panel facing up.
4. **Remove the access panel** on page 29.
5. **Remove the PCIe air baffle** on page 31.
6. **Remove the system air baffle** on page 32.
7. Disconnect the fan cable.
8. Remove the fan cable from the cable clip and then remove the system fan.

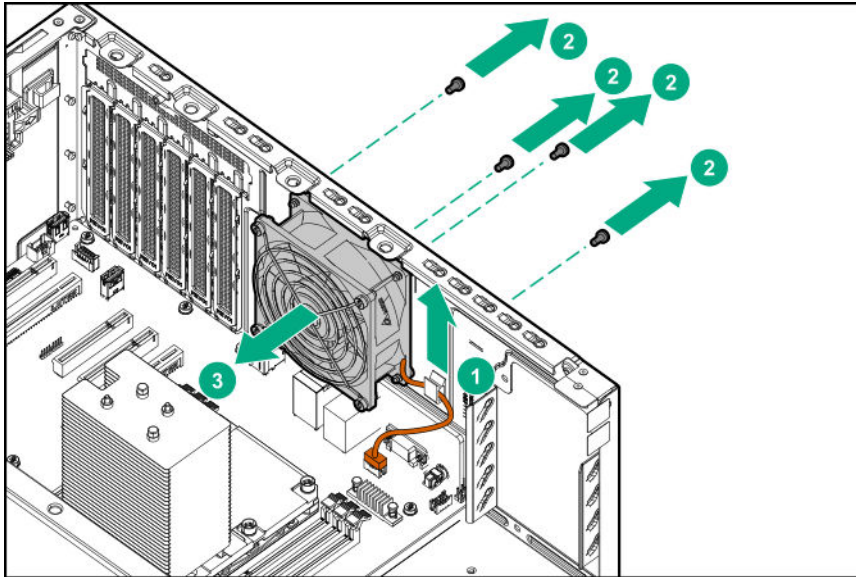

To replace the component, reverse the removal procedure.

Replacing the redundant fans

Replacing the redundant PCIe fan module

Prerequisites

Before you perform this procedure, make sure that you have T-15 Torx screwdriver available.

Procedure

1. **Power down the server** on page 27.
2. Remove all power:
 - a. Disconnect each power cord from the power source.
 - b. Disconnect each power cord from the server.
3. Do one of the following:
 - Server in rack mode: **Remove the server from the rack** on page 28.
 - Server in tower mode: Place the server on its side and access panel facing up.
4. **Remove the access panel** on page 29.
5. **Remove the PCIe air baffle** on page 31.
6. **Remove the system air baffle** on page 32.
7. Disconnect all fan cables from the system board.
8. Remove the cables from the cable clip.
9. Remove the redundant PCIe fan module.

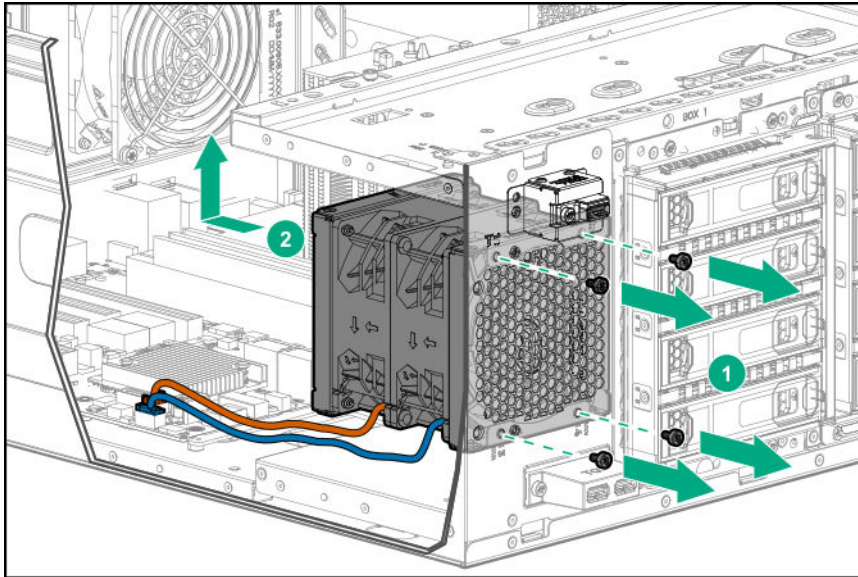

To replace the component, reverse the removal procedure.

Replacing the redundant system fan module

Prerequisites

Before you perform this procedure, make sure that you have T-15 Torx screwdriver available.

Procedure

1. **Power down the server** on page 27.
2. Remove all power:
 - a. Disconnect each power cord from the power source.
 - b. Disconnect each power cord from the server.
3. Do one of the following:
 - Server in rack mode: **Remove the server from the rack** on page 28.
 - Server in tower mode: Place the server on its side and access panel facing up.
4. **Remove the access panel** on page 29.
5. **Remove the PCIe air baffle** on page 31.
6. **Remove the system air baffle** on page 32.
7. Disconnect all fan cables from the system board.
8. Remove the cables from the cable clip.
9. Remove the redundant fan module.

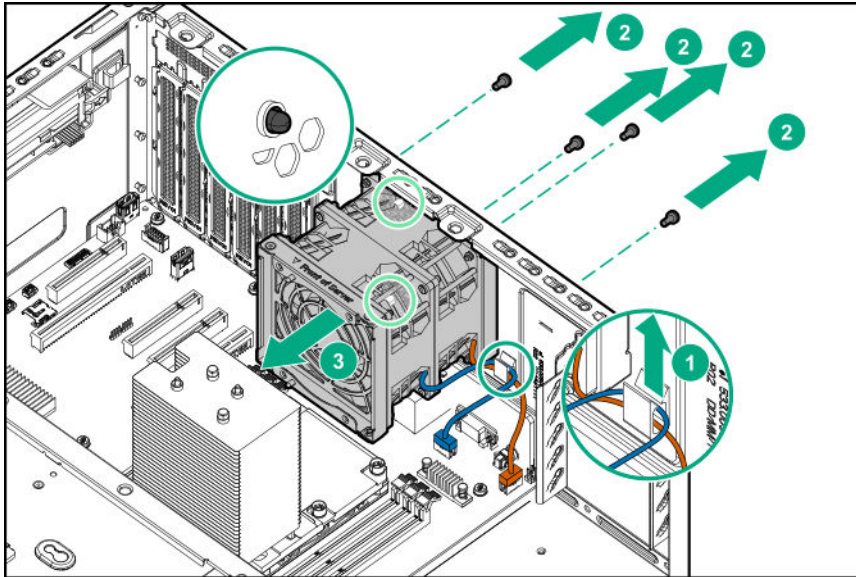

To replace the component, reverse the removal procedure.

System battery information

The server contains an internal lithium manganese dioxide, a vanadium pentoxide, or an alkaline battery that provides power to the real-time clock. If this battery is not properly handled, a risk of the fire and burns exists. To reduce the risk of personal injury:

- Do not attempt to recharge the battery.
- Do not expose the battery to temperatures higher than 60°C (140°F).
- Do not disassemble, crush, puncture, short external contacts, or dispose the battery in fire or water.
- If the server no longer automatically displays the correct date and time, then replace the battery that provides power to the real-time clock. Under normal use, battery life is 5 to 10 years.

Replacing the system battery

Procedure

1. **Power down the server** on page 27.
2. Remove all power:
 - a. Disconnect each power cord from the power source.
 - b. Disconnect each power cord from the server.
3. Do one of the following:
 - Server in rack mode: **Remove the server from the rack** on page 28.
 - Server in tower mode: Place the server on its side and access panel facing up.
4. **Remove the access panel** on page 29.

5. **Remove the PCIe air baffle** on page 31.
6. **Remove the system air baffle** on page 32.
7. **Locate the battery on the system board.**
8. Slightly push the metal tab, and then remove the system battery from its socket.

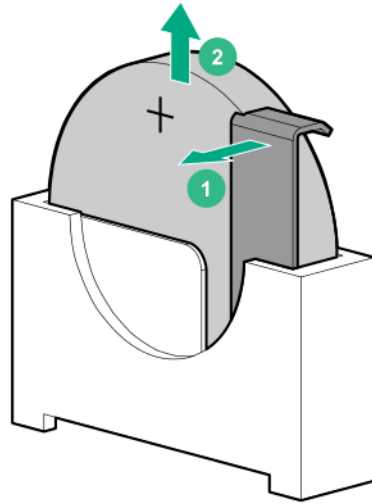

To replace the component, reverse the removal procedure.

Replacing the smart storage battery

Procedure

1. **Power down the server** on page 27.
2. Remove all power:
 - a. Disconnect each power cord from the power source.
 - b. Disconnect each power cord from the server.
3. Do one of the following:
 - Server in rack mode: **Remove the server from the rack** on page 28.
 - Server in tower mode: Place the server on its side and access panel facing up.
4. **Remove the access panel** on page 29.
5. **Remove the PCIe air baffle** on page 31.
6. **Remove the system air baffle** on page 32.
7. Disconnect the battery cable from the system board connector.
8. Remove the Smart Storage Battery.

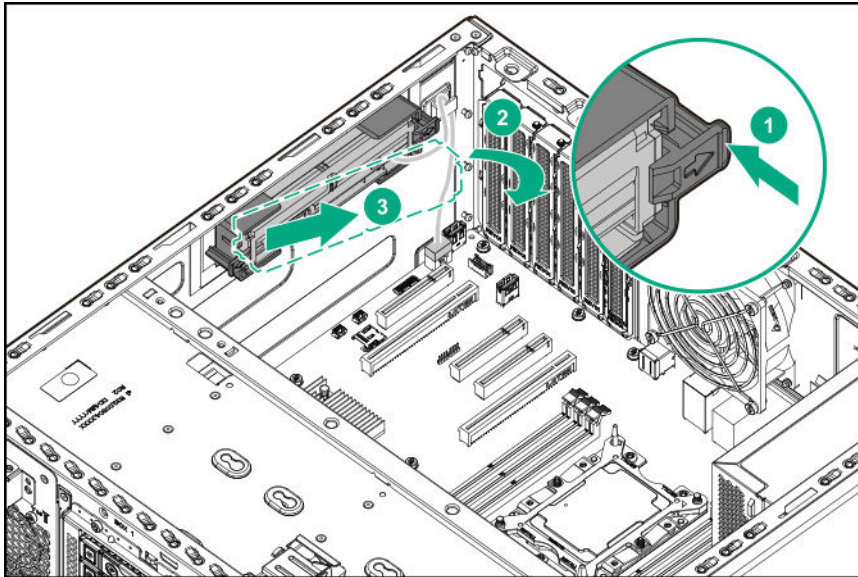

To replace the component, reverse the removal procedure.

Replacing the system board assembly

Prerequisites

Before you perform this procedure, make sure that you have T-15 Torx screwdriver available.

Procedure

1. **Power down the server** on page 27.
2. Remove all power:
 - a. Disconnect each power cord from the power source.
 - b. Disconnect each power cord from the server.
3. Do one of the following:
 - Server in rack mode: **Remove the server from the rack** on page 28.
 - Server in tower mode: Place the server on its side and access panel facing up.
4. **Remove the access panel** on page 29.
5. **Remove the PCIe air baffle** on page 31.
6. **Remove the system air baffle** on page 32.
7. Disconnect all cables connected to the system board assembly.
8. If installed, remove all the PCIe cards.
9. **Remove all fans.**
10. **Remove all DIMMs.**
11. If installed, **remove the Smart Storage Battery assembly.**

12. Remove the smart storage battery holder.
13. Remove the USB device from the system board.
14. Remove the processor heatsink assembly:
 - a. Allow the heatsink to cool.
 - b. Loosen the heatsink nuts in the order specified by the label on the heatsink.

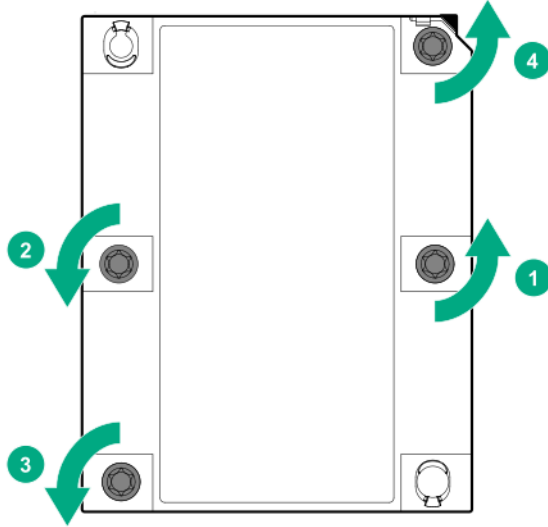

- c. Lift the processor heatsink assembly and move it away from the system board.
 - d. Turn the assembly over and place it on a work surface with the processor facing up.
 - e. Install the dust cover.
15. Loosen the screws on the system board.
16. Remove the system board.

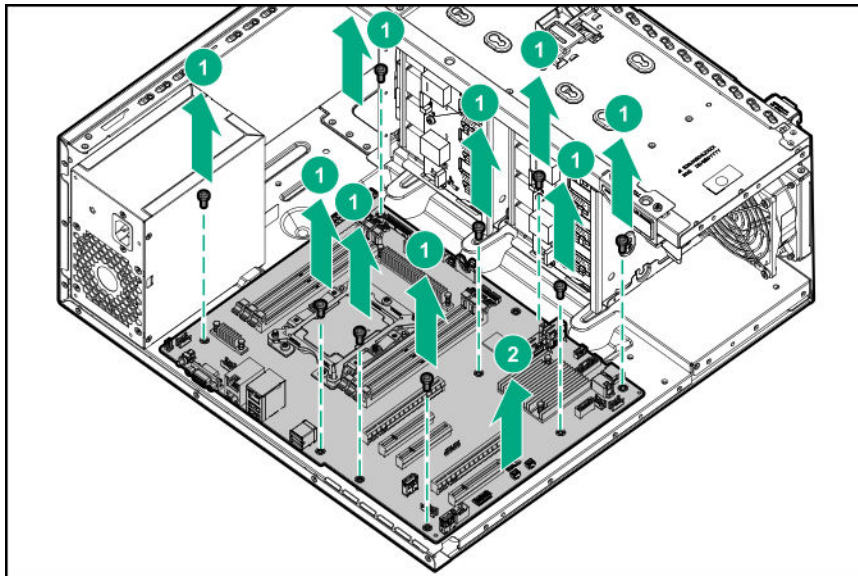

To replace the component, reverse the removal procedure.

Re-entering the server serial number and product ID

After you replace the system board, the server serial number and the product ID must be configured:

Procedure

1. Access System Utilities. During POST, press **F9**.
2. On the System Utilities home screen, select **System Configuration > BIOS/Platform Configuration (RBSU) > Advanced Options > Advanced Service Options**.
3. Select the Serial Number field and press **Enter**.

The following alert appears:

```
The serial number is modified by qualified service personnel and must match the serial number located on the chassis.
```

4. Click **OK**.
5. Type the serial number and press **Enter**.
6. Select the Product ID field and press **Enter**.

The following alert appears:

```
Product ID is modified only by qualified personnel. This value must match the product ID located on the chassis.
```

7. Type the product ID and press **Enter**.
8. Press **F10** to save the configuration.

The procedure is complete.

HPE Trusted Platform Module 2.0 Gen10 Option

The HPE Trusted Platform Module 2.0 Gen10 Option is not a customer-removable part.



CAUTION:

If the TPM is removed from the original server and powered up on a different server, data stored in the TPM including keys will be erased.

If you suspect a TPM board failure, leave the TPM installed and remove the system board (**Replacing the system board assembly** on page 59). Contact a Hewlett Packard Enterprise authorized service provider for a replacement system board and TPM board.

Troubleshooting

Troubleshooting resources

Troubleshooting resources are available for HPE Gen10 server products in the following documents:

- *Troubleshooting Guide for HPE ProLiant Gen10 servers* provides procedures for resolving common problems and comprehensive courses of action for fault isolation and identification, issue resolution, and software maintenance.
- *Error Message Guide for HPE ProLiant Gen10 servers and HPE Synergy* provides a list of error messages and information to assist with interpreting and resolving error messages.
- *Integrated Management Log Messages and Troubleshooting Guide for HPE ProLiant Gen10 and HPE Synergy* provides IML messages and associated troubleshooting information to resolve critical and cautionary IML events.

To access the troubleshooting resources, see the Hewlett Packard Enterprise Information Library (<http://www.hpe.com/info/gen10-troubleshooting>).

Diagnostic tools

Product QuickSpecs

For more information about product features, specifications, options, configurations, and compatibility, see the product QuickSpecs on the Hewlett Packard Enterprise website (<http://www.hpe.com/info/qs>).

UEFI System Utilities

The UEFI System Utilities is embedded in the system ROM. Its features enable you to perform a wide range of configuration activities, including:

- Configuring system devices and installed options.
- Enabling and disabling system features.
- Displaying system information.
- Selecting the primary boot controller or partition.
- Configuring memory options.
- Launching other preboot environments.

HPE servers with UEFI can provide:

- Support for boot partitions larger than 2.2 TB. Such configurations could previously only be used for boot drives when using RAID solutions.
- Secure Boot that enables the system firmware, option card firmware, operating systems, and software collaborate to enhance platform security.
- UEFI Graphical User Interface (GUI)
- An Embedded UEFI Shell that provides a preboot environment for running scripts and tools.
- Boot support for option cards that only support a UEFI option ROM.

Selecting the boot mode

This server provides two **Boot Mode** configurations: UEFI Mode and Legacy BIOS Mode. Certain boot options require that you select a specific boot mode. By default, the boot mode is set to **UEFI Mode**. The system must boot in **UEFI Mode** to use certain options, including:

- Secure Boot, UEFI Optimized Boot, Generic USB Boot, IPv6 PXE Boot, iSCSI Boot, and Boot from URL
- Fibre Channel/FCoE Scan Policy

NOTE:

The boot mode you use must match the operating system installation. If not, changing the boot mode can impact the ability of the server to boot to the installed operating system.

Prerequisite

When booting to **UEFI Mode**, leave **UEFI Optimized Boot** enabled.

Procedure

1. From the **System Utilities** screen, select **System Configuration > BIOS/Platform Configuration (RBSU) > Boot Options > Boot Mode**.
2. Select a setting.
 - **UEFI Mode** (default)—Configures the system to boot to a UEFI compatible operating system.
 - **Legacy BIOS Mode**—Configures the system to boot to a traditional operating system in Legacy BIOS compatibility mode.
3. Save your setting.
4. Reboot the server.

Secure Boot

Secure Boot is a server security feature that is implemented in the BIOS and does not require special hardware. Secure Boot ensures that each component launched during the boot process is digitally signed and that the signature is validated against a set of trusted certificates embedded in the UEFI BIOS. Secure Boot validates the software identity of the following components in the boot process:

- UEFI drivers loaded from PCIe cards
- UEFI drivers loaded from mass storage devices
- Preboot UEFI Shell applications
- OS UEFI boot loaders

When Secure Boot is enabled:

- Firmware components and operating systems with boot loaders must have an appropriate digital signature to execute during the boot process.
- Operating systems must support Secure Boot and have an EFI boot loader signed with one of the authorized keys to boot. For more information about supported operating systems, see <http://www.hpe.com/servers/ossupport>.

You can customize the certificates embedded in the UEFI BIOS by adding or removing your own certificates, either from a management console directly attached to the server, or by remotely connecting to the server using the iLO Remote Console.

You can configure Secure Boot:

- Using the **System Utilities** options described in the following sections.
- Using the iLO RESTful API to clear and restore certificates. For more information, see the Hewlett Packard Enterprise website (<http://www.hpe.com/info/redfish>).
- Using the `secboot` command in the Embedded UEFI Shell to display Secure Boot databases, keys, and security reports.

Launching the Embedded UEFI Shell

Use the **Embedded UEFI Shell** option to launch the Embedded UEFI Shell. The Embedded UEFI Shell is a pre-boot command-line environment for scripting and running UEFI applications, including UEFI boot

loaders. The Shell also provides CLI-based commands you can use to obtain system information, and to configure and update the system BIOS.

Prerequisites

Embedded UEFI Shell is set to enabled.

Procedure

1. From the **System Utilities** screen, select **Embedded Applications > Embedded UEFI Shell**.

The **Embedded UEFI Shell** screen appears.

2. Press any key to acknowledge that you are physically present.

This step ensures that certain features, such as disabling **Secure Boot** or managing the **Secure Boot** certificates using third-party UEFI tools, are not restricted.

3. If an administrator password is set, enter it at the prompt and press **Enter**.

The `Shell>` prompt appears.

4. Enter the commands required to complete your task.

5. Enter the `exit` command to exit the Shell.

Intelligent Provisioning

Intelligent Provisioning is a single-server deployment tool embedded in ProLiant servers and HPE Synergy compute modules. Intelligent Provisioning simplifies server setup, providing a reliable and consistent way to deploy servers.

Intelligent Provisioning prepares the system for installing original, licensed vendor media and Hewlett Packard Enterprise-branded versions of OS software. Intelligent Provisioning also prepares the system to integrate optimized server support software from the Service Pack for ProLiant (SPP). SPP is a comprehensive systems software and firmware solution for ProLiant servers, server blades, their enclosures, and HPE Synergy compute modules. These components are preloaded with a basic set of firmware and OS components that are installed along with Intelligent Provisioning.

IMPORTANT:

HPE ProLiant XL servers do not support operating system installation with Intelligent Provisioning, but they do support the maintenance features. For more information, see "Performing Maintenance" in the *Intelligent Provisioning User Guide* and online help.

After the server is running, you can update the firmware to install additional components. You can also update any components that have been outdated since the server was manufactured.

To access Intelligent Provisioning:

- Press **F10** from the POST screen.
- From the iLO web browser user interface using **Always On**. **Always On** allows you to access Intelligent Provisioning without rebooting your server.

Intelligent Provisioning operation

Intelligent Provisioning includes the following components:

- Critical boot drivers
- Active Health System (AHS)
- Erase Utility
- Deployment Settings

! **IMPORTANT:**

- Although your server is pre-loaded with firmware and drivers, you should update the firmware upon initial setup to ensure you have the latest versions. Also, downloading and updating the latest version of Intelligent Provisioning ensures the latest supported features are available.
- For ProLiant servers, firmware is updated using the Intelligent Provisioning Firmware Update utility.
- Do not update firmware if the version you are currently running is required for compatibility.

NOTE:

Intelligent Provisioning does not function within multihomed configurations. A multihomed host is one that is connected to two or more networks or has two or more IP addresses.

Intelligent Provisioning provides installation help for the following operating systems:

- Microsoft Windows Server
- Red Hat Enterprise Linux
- SUSE Linux Enterprise Server
- VMware ESXi/vSphere Custom Image

Not all versions of an OS are supported. For information about specific versions of a supported operating system, see the OS Support Matrix on the Hewlett Packard Enterprise website (<http://www.hpe.com/info/ossupport>).

HPE Insight Remote Support

Hewlett Packard Enterprise strongly recommends that you register your device for remote support to enable enhanced delivery of your Hewlett Packard Enterprise warranty, HPE support services, or Hewlett Packard Enterprise contractual support agreement. Insight Remote Support supplements your monitoring continuously to ensure maximum system availability by providing intelligent event diagnosis, and automatic, secure submission of hardware event notifications to Hewlett Packard Enterprise, which will initiate a fast and accurate resolution, based on your product's service level. Notifications can be sent to your authorized Hewlett Packard Enterprise Channel Partner for onsite service, if configured and available in your country.

For more information, see *Insight Remote Support and Insight Online Setup Guide for ProLiant Servers and BladeSystem c-Class Enclosures* on the **Hewlett Packard Enterprise website**. Insight Remote Support is available as part of Hewlett Packard Enterprise Warranty, HPE support services, or Hewlett Packard Enterprise contractual support agreement.

USB support

Hewlett Packard Enterprise Gen10 servers support all USB operating speeds depending on the device that is connected to the server.

External USB functionality

Hewlett Packard Enterprise provides external USB support to enable local connection of USB devices for server administration, configuration, and diagnostic procedures.

For additional security, external USB functionality can be disabled through USB options in UEFI System Utilities.

HPE Smart Storage Administrator

HPE SSA is the main tool for configuring arrays on HPE Smart Array SR controllers. It exists in three interface formats: the HPE SSA GUI, the HPE SSA CLI, and HPE SSA Scripting. All formats provide support for configuration tasks. Some of the advanced tasks are available in only one format.

The diagnostic features in HPE SSA are also available in the standalone software HPE Smart Storage Administrator Diagnostics Utility CLI.

During the initial provisioning of the server or compute module, an array is required to be configured before the operating system can be installed. You can configure the array using SSA.

HPE SSA is accessible both offline (either through HPE Intelligent Provisioning or as a standalone bootable ISO image) and online:

- Accessing HPE SSA in the offline environment



IMPORTANT:

If you are updating an existing server in an offline environment, obtain the latest version of HPE SSA through Service Pack for ProLiant before performing configuration procedures.

Using one of multiple methods, you can run HPE SSA before launching the host operating system. In offline mode, users can configure or maintain detected and supported devices, such as optional Smart Array controllers and integrated Smart Array controllers. Some HPE SSA features are only available in the offline environment, such as setting the boot controller and boot volume.

- Accessing HPE SSA in the online environment

This method requires an administrator to download the HPE SSA executables and install them. You can run HPE SSA online after launching the host operating system.

For more information, see *HPE Smart Array SR Gen10 Configuration Guide* at the [Hewlett Packard Enterprise website](#).

Component identification

Front panel components

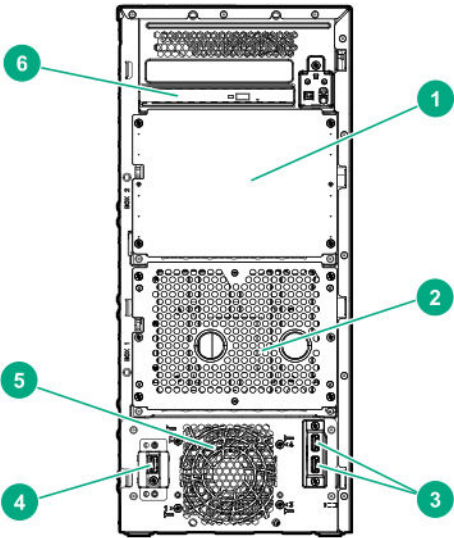

| Item | Description |
|------|------------------------------------|
| 1 | Box 2 |
| 2 | Box 1 |
| 3 | USB 3.0 connectors |
| 4 | iLO service port |
| 5 | PCIe Fan |
| 6 | Slim Optical Disc Drive (Optional) |

Front panel LEDs and buttons

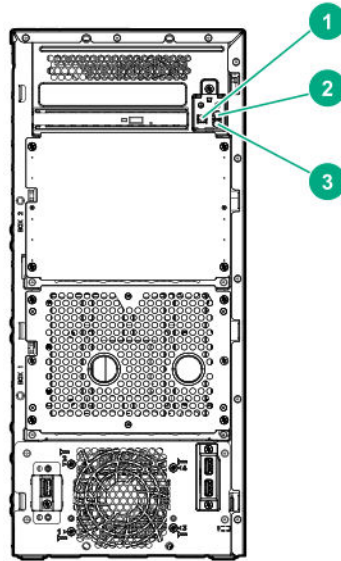

| Item | Description | Status |
|------|--|--|
| 1 | Power On/Standby button and system power LED | <p>Solid green = System on</p> <p>Flashing green (1 flash per second) = Performing power on sequence</p> <p>Solid amber = System in standby</p> <p>Off = No power present</p> <p>If the system power LED is off, verify the following conditions:</p> <ul style="list-style-type: none"> • Facility power is present. • The power supply is installed and is working correctly. • The power cord is attached and is connected to a power source. • The front I/O cable is connected. |
| 2 | Health LED | <p>Solid green = Normal</p> <p>Flashing green (1 flash per second) = iLO is rebooting.</p> <p>Flashing amber = System degraded</p> <p>Flashing red (1 flash per second) = System critical¹</p> |
| 3 | NIC status LED | <p>Solid green = Link to network</p> <p>Flashing green (1 flash per second) = Network active</p> <p>Off = No network activity</p> |

¹ If the health LED indicates a degraded or critical state, review the system IML or use iLO to review the system health status.

When all three LEDs described in this table and the UID button/LED on the rear panel flash simultaneously, a power fault has occurred. For more information, see **Power fault LEDs** on page 71. For the location of the UID button/LED on the rear panel, see **Rear panel LEDs** on page 72 .

Rear panel components

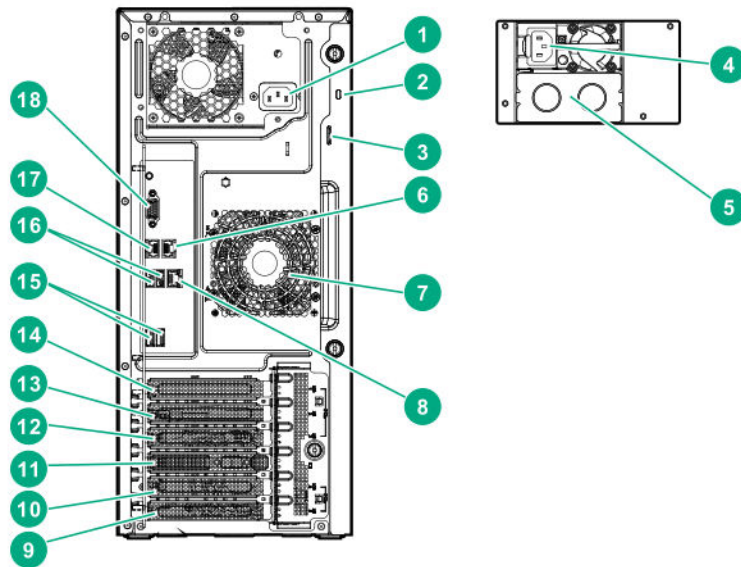

| Item | Description |
|------|--|
| 1 | Non-hot-plug power supply |
| 2 | Kensington security slot |
| 3 | Padlock eye |
| 4 | Power supply bay 1 of the hot-plug power supply (optional) |
| 5 | Power supply bay 2 of the hot-plug power supply (optional) |
| 6 | NIC port 1 |
| 7 | System fan |
| 8 | iLO Management port |
| 9 | Slot 5 PCIe3x8 (4, 1) |
| 10 | Slot 4 PCIe3 x16 (16 8, 4, 1) |
| 11 | Serial port (optional) |
| 12 | Slot 3 PCIe3 x8 (8, 4, 1) |
| 13 | Slot 2 PCIe3 x8 (4, 1) |

Table Continued

| Item | Description |
|------|--------------------------------|
| 14 | Slot 1 PCIe3 x16 (16, 8, 4, 1) |
| 15 | USB 3.0 port |
| 16 | USB 2.0 port |
| 17 | NIC port 2 |
| 18 | Video port |

UID button functionality

The UID button can be used to display the Server Health Summary when the server will not power on. For more information, see the latest *HPE iLO User Guide* on the [Hewlett Packard Enterprise website](#).

Power fault LEDs

The following table provides a list of power fault LEDs, and the subsystems that are affected. Not all power faults are used by all servers.

| Subsystem | LED behavior |
|--|--------------|
| System board | 1 flash |
| Processor | 2 flashes |
| Memory | 3 flashes |
| Removable HPE Flexible Smart Array controller/Smart SAS HBA controller | 6 flashes |
| System board PCIe slots | 7 flashes |
| Power backplane or storage backplane | 8 flashes |
| Power supply | 9 flashes |

Rear panel LEDs

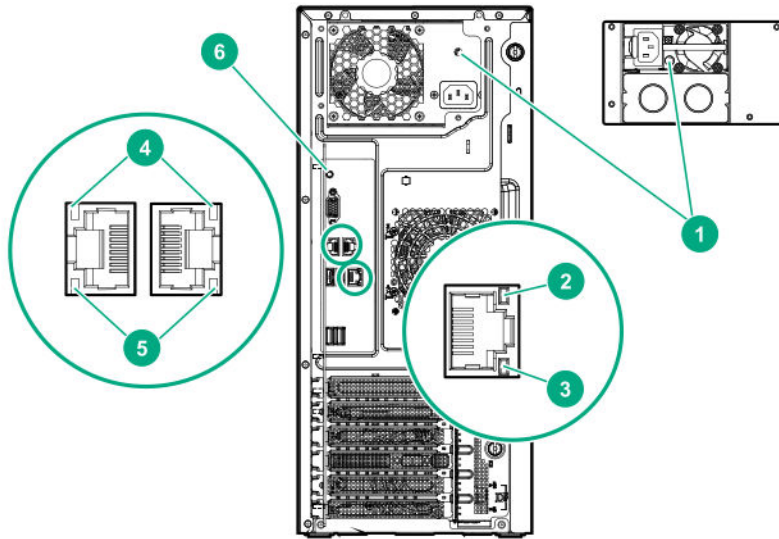

| Item | Description | Status |
|------|------------------|--|
| 1 | Power supply LED | Solid green = Normal Off = One or more of the following conditions exists: <ul style="list-style-type: none"> • Power is unavailable • Power supply failed • Power supply is in standby mode • Power supply error |
| 2 | iLO link LED | Green = Linked to network connection Off = No network connection |
| 3 | iLO activity LED | Green or flashing green = Network activity Off = No network activity |
| 4 | NIC link LED | Green = Linked to network Off = No network connection |

Table Continued

| Item | Description | Status |
|------|------------------|---|
| 5 | NIC activity LED | Green or flashing green = Network activity Off = No network activity |
| 6 | UID button/LED | Solid blue = Activated Flashing blue: <ul style="list-style-type: none"> • 1 flash per second = Remote management or firmware upgrade in progress • 4 flashes per second = iLO manual reboot sequence initiated • 8 flashes per second = iLO manual reboot sequence in progress Off = Deactivated |

! **IMPORTANT:** Consider NIC as HPE Ethernet 1GB 2-port 332i Adapter whose performance is a PCIe Gen2 x1 device.

System board components

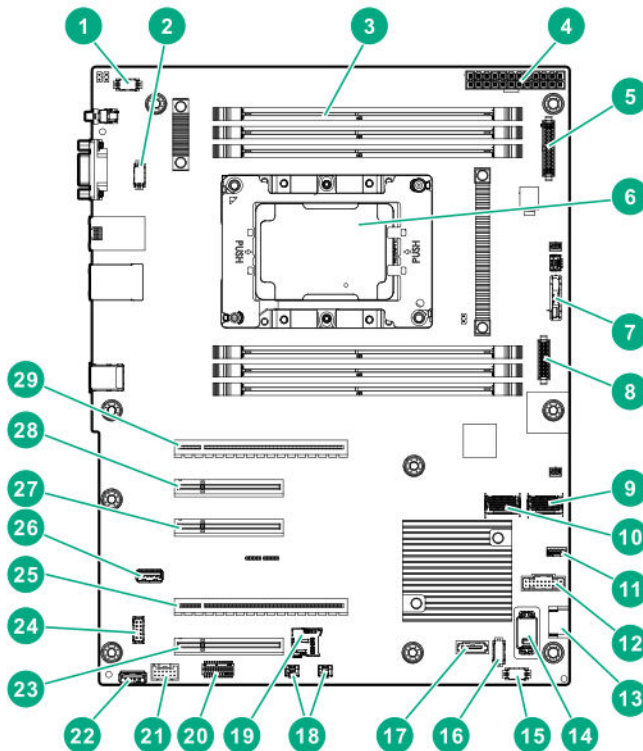

| Item | Description |
|-------------|-------------------------------------|
| 1 | Fan connector 4 (system fan) |
| 2 | Fan connector 3 (system fan) |
| 3 | DIMM slots |
| 4 | 24-pin power supply connector |
| 5 | RPSU connector |
| 6 | Processor |
| 7 | System Battery |
| 8 | Front I/O connector |
| 9 | x4 SATA port 1 |
| 10 | x4 SATA port 2 |
| 11 | iLO service port connector |
| 12 | Front USB 3.0 connector |
| 13 | SATA port 9 |
| 14 | TPM connector |
| 15 | Fan connector 1 (PCIe fan) |
| 16 | Fan connector 2 (PCIe fan) |
| 17 | SATA port 10 |
| 18 | Storage backup power connectors |
| 19 | microSD slot ¹ |
| 20 | System maintenance switch |
| 21 | Smart storage battery connector |
| 22 | Internal USB 2.0 connector |
| 23 | Slot 5 PCIe3 x8 (4, 1) ² |
| 24 | Serial port connector |
| 25 | Slot 4 PCIe3 x16 (16, 8, 4, 1) |

Table Continued

| Item | Description |
|------|--------------------------------|
| 26 | Internal USB 3.0 connector |
| 27 | Slot 3 PCIe3 x8 (8, 4, 1) |
| 28 | Slot 2 PCIe3 x8 (4, 1) |
| 29 | Slot 1 PCIe3 x16 (16, 8, 4, 1) |

¹ If the microSD slot does not appear in Device Manager under Windows, click **View** in the tool bar and then select **show hidden device**.

² Although the Speed of slot 5 is designed for 32Gb/s, the actual running speed will be lower than it was designed. Hence, slot 5 will be least recommended for usage.

System maintenance switch descriptions

| Position | Default | Function |
|--------------------|---------|--|
| S1 ¹ | Off | Off = iLO security is enabled. On = iLO security is disabled. |
| S2 | — | Reserved |
| S3 | Off | Reserved |
| S4 | Off | Reserved |
| S5 ¹ | Off | Off = Power-on password is enabled. On = Power-on password is disabled. |
| S6 ^{1, 2} | Off | Off = No function On = Restore default manufacturing settings |
| S7 | — | Reserved |
| S8 | — | Reserved |
| S9 | — | Reserved |
| S10 | — | Reserved |
| S11 | — | Reserved |
| S12 | — | Reserved |

¹You can access the redundant ROM by setting S1, S5, and S6 to On.

²When the system maintenance switch position 6 is set to the On position, the system is prepared to restore all configuration settings to their manufacturing defaults.

When the system maintenance switch position 6 is set to the On position and Secure Boot is enabled, some configurations cannot be restored. For more information, see Secure Boot configuration.

DIMM slot locations

DIMM slots are numbered sequentially (1 through 6) for the processor.

The arrow points to the front of the server.

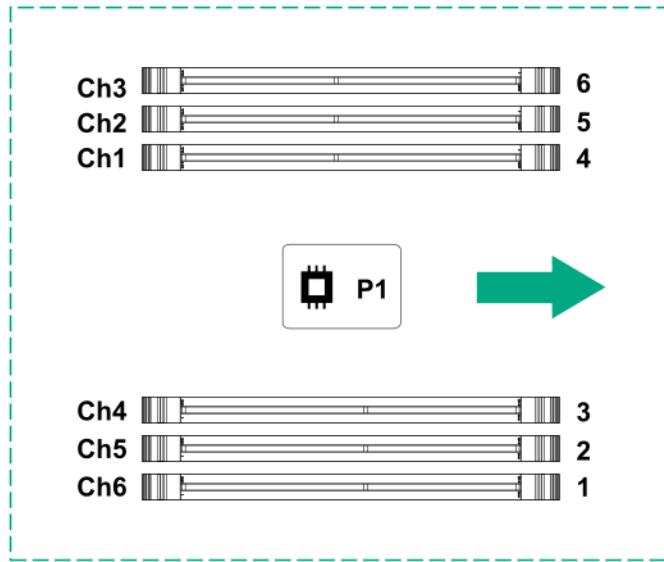

! **IMPORTANT:**
A3DC only supports DIMM module with 32G dual rank.

Drives

LFF drive LED definitions

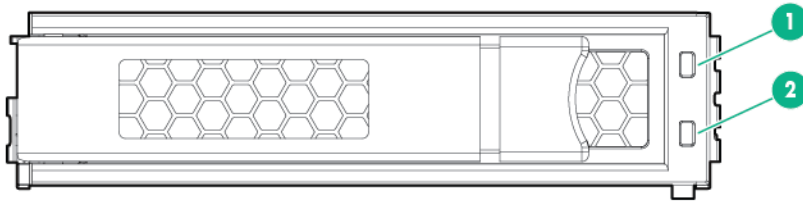

| Item | Definition |
|------|-------------------------|
| 1 | Fault/UID (amber/blue) |
| 2 | Online/Activity (green) |

| Online/Activity LED (green) | Fault/UID LED (amber/blue) | Definition |
|-----------------------------|----------------------------|--|
| On, off, or flashing | Alternating amber and blue | One or more of the following conditions exist: <ul style="list-style-type: none"> The drive has failed. A predictive failure alert has been received for this drive. The drive is selected by a management application. |
| On, off, or flashing | Solid blue | One or both of the following conditions exist: <ul style="list-style-type: none"> The drive is operating normally. The drive is selected by a management application. |
| On | Flashing amber | A predictive failure alert has been received for this drive. Replace the drive as soon as possible. |
| On | Off | The drive is online but is not currently active. |
| 1 flash per second | Flashing amber | Do not remove the drive. Removing the drive might terminate the current operation and cause data loss. The drive is part of an array that is undergoing capacity expansion or stripe migration, but a predictive failure alert has been received for this drive. To minimize the risk of data loss, do not remove the drive until the expansion or migration is complete. |
| 1 flash per second | Off | Do not remove the drive. Removing the drive might terminate the current operation and cause data loss. The drive is rebuilding, erasing, or is part of an array that is undergoing capacity expansion or stripe migration. |
| 4 flashes per second | Flashing amber | The drive is active but a predictive failure alert has been received for the drive. Replace the drive as soon as possible. |
| 4 flashed per second | Off | The drive is active and is operating normally. |
| Off | Solid amber | A critical fault condition has been identified for this drive and the controller has placed it offline. Replace the drive as soon as possible. |
| Off | Flashing amber | A predictive failure alert has been received for this drive. Replace the drive as soon as possible. |
| Off | Off | The drive is offline, a spare, or not configured as part of an array. |

Hot-plug drive LED definitions

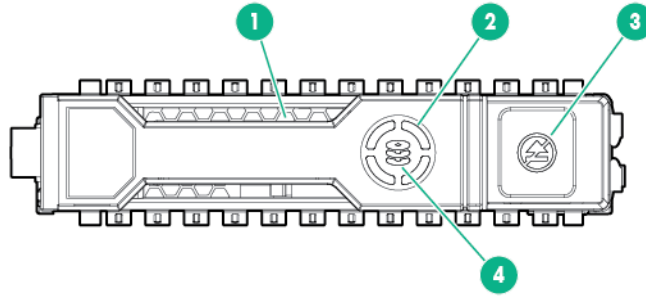

| Item | LED | Status | Definition |
|------|---------------|----------------------|--|
| 1 | Locate | Solid blue | The drive is being identified by a host application. |
| | | Flashing blue | The drive carrier firmware is being updated or requires an update. |
| 2 | Activity ring | Rotating green | Drive activity |
| | | Off | No drive activity |
| 3 | Do not remove | Solid white | Do not remove the drive. Removing the drive causes one or more of the logical drives to fail. |
| | | Off | Removing the drive does not cause a logical drive to fail. |
| 4 | Drive status | Solid green | The drive is a member of one or more logical drives. |
| | | Flashing green | The drive is doing one of the following: <ul style="list-style-type: none"> Rebuilding Performing a RAID migration Performing a strip size migration Performing a capacity expansion Performing a logical drive extension Erasing Spare part activation |
| | | Flashing amber/green | The drive is a member of one or more logical drives and predicts the drive will fail. |
| | | Flashing amber | The drive is not configured and predicts the drive will fail. |
| | | Solid amber | The drive has failed. |
| | | Off | The drive is not configured by a RAID controller or a spare drive. |

Enabling embedded chipset SATA controller support

Use the **Embedded SATA Configuration** option to enable embedded chipset SATA (Serial Advanced Technology Attachment) controller support. You can select AHCI or HPE Smart Array S100i SR Gen10

SW RAID support. Make sure that you are using the correct operating system drivers for your selected option.

⚠ CAUTION:

Dynamic Smart Array is not supported when the boot mode is configured to Legacy BIOS Mode. Enabling Dynamic Smart Array RAID results in data loss or data corruption on existing SATA drives. Back up all drives before enabling this option.

See your operating system documentation before enabling SATA AHCI support to ensure your base media drivers support this feature.

Prerequisites

- The correct operating system drivers for your selected option.
- **Boot Mode** is set to **UEFI Mode**.

Procedure

1. From the **System Utilities** screen, select **System Configuration > BIOS/Platform Configuration (RBSU) > Storage Options > SATA Controller Options > Embedded SATA Configuration**.
2. Ensure that you are using the correct AHCI or RAID system drivers for your SATA option.
3. Select a setting.
 - **SATA AHCI Support**—Enables the embedded chipset SATA controller for AHCI.
 - **Smart Array SW RAID Support**—Enables the embedded chipset SATA controller for Dynamic Smart Array RAID.
4. Save your setting.

SFF SmartDrive components

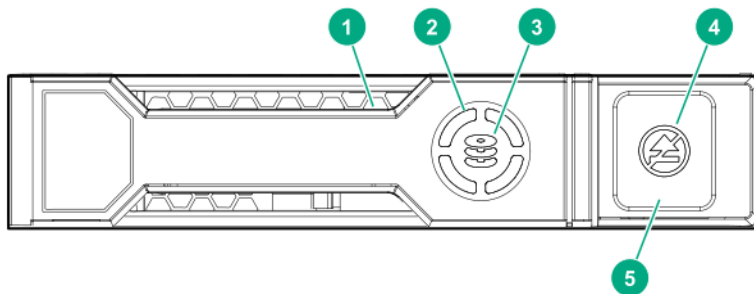

| Item | Description | Status |
|------|-------------------------|---|
| 1 | Locate LED ¹ | <p>Solid blue = The drive is being identified by a host application.</p> <p>Flashing blue = The drive carrier firmware is being updated or requires an update.</p> |
| 2 | Activity ring LED | <p>Rotating green = Drive activity</p> <p>Off = No drive activity</p> |
| 3 | Drive status LED | <p>Solid green = The drive is a member of one or more logical drives.</p> <p>Flashing green = The drive is rebuilding or performing a RAID migration, stripe size migration, capacity expansion, or logical drive extension, or is erasing.</p> <p>Flashing amber/green = The drive is a member of one or more logical drives and predicts the drive will fail.</p> <p>Flashing amber = The drive is not configured and predicts the drive will fail.</p> <p>Solid amber = The drive has failed.</p> <p>Off = The drive is not configured by a RAID controller.</p> |
| 4 | Do not remove LED | <p>Solid white = Do not remove the drive. Removing the drive causes one or more of the logical drives to fail.</p> <p>Off = The drive can be removed. Removing the drive does not cause a logical drive to fail.</p> |
| 5 | Do not remove button | Press to open the release lever. |

¹ The blue locate LED is behind the release lever and is visible when illuminated.

Drive Numbering

The following images show the drive numbering for each of the supported drive configurations. For drive box numbering information, see **Front panel components** on page 68.

With optional drive cages installed, the server supports up to 8 LFF non-hot-plug drives, 8 LFF hot-plug drives, or 16 SFF hot-plug drives. If only one drive cage is installed, it must be installed in box 1. The server does not support mixing SFF and LFF drives.

Hewlett Packard Enterprise recommends that you populate drive bays starting with the lowest drive number. Drives are numbered from left to right in each component box.

- Four-bay LFF non-hot-plug drive model

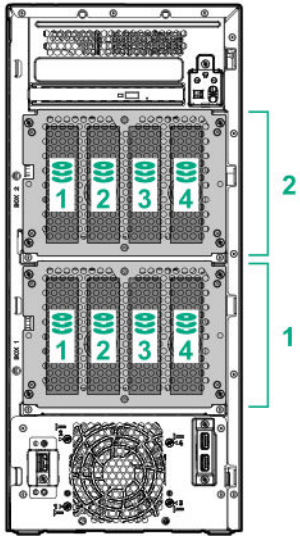

- Four-bay LFF hot-plug drive model

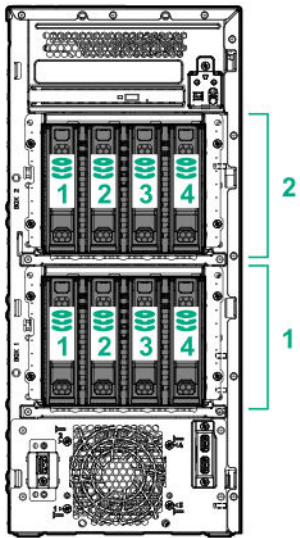

- Eight-bay SFF hot-plug drive model

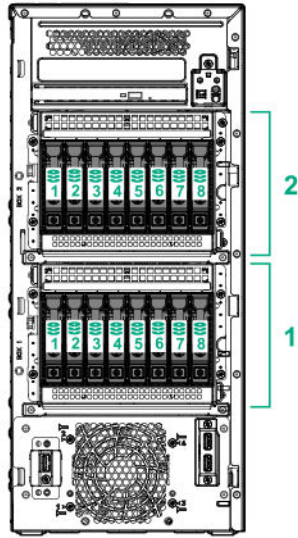

Fan locations

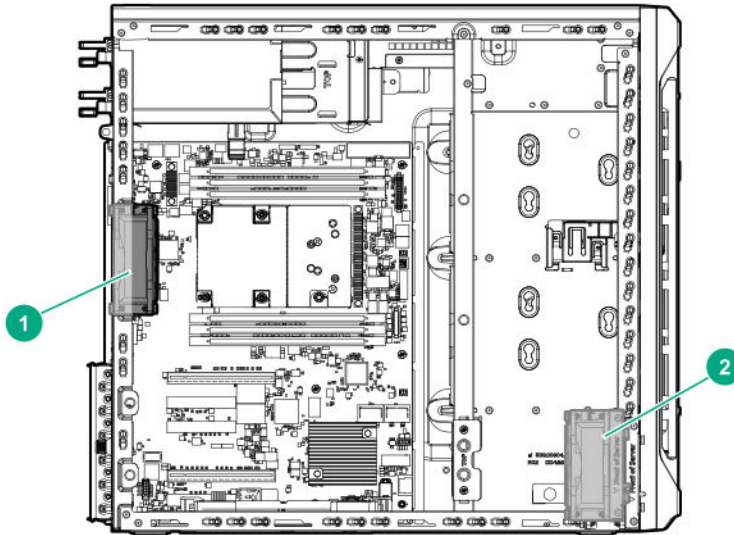

| Item | Description |
|------|--|
| 1 | Default system fan module (92 x 32 mm) |
| 2 | Default PCIe fan module (92 X 32 mm) |

The server also supports redundant fan options, see Redundant fan option.

Cabling

Cabling guidelines

The cable colors in the cabling diagrams used in this chapter are for illustration purposes only. Most of the server cables are black.

Observe the following guidelines when working with server cables.

Before connecting cables

- Note the port labels on the PCA components. Not all of these components are used by all servers:
 - System board ports
 - Drive and power supply backplane ports
 - Expansion board ports (controllers, adapters, expanders, risers, and similar boards)
- Note the label near each cable connector. This label indicates the destination port for the cable connector.
- Some data cables are pre-bent. Do not unbend or manipulate the cables.
- To prevent mechanical damage or depositing oil that is present on your hands, and other contamination, do not touch the ends of the connectors.

When connecting cables

- Before connecting a cable to a port, lay the cable in place to verify the length of the cable.
- Use the internal cable management features to properly route and secure the cables.
- When routing cables, be sure that the cables are not in a position where they can be pinched or crimped.
- Avoid tight bend radii to prevent damaging the internal wires of a power cord or a server cable. Never bend power cords and server cables tight enough to cause a crease in the sheathing.
- Make sure that the excess length of cables are properly secured to avoid excess bends, interference issues, and airflow restriction.
- To prevent component damage and potential signal interference, make sure that all cables are in their appropriate routing position before installing a new component and before closing up the server after hardware installation/maintenance.

When disconnecting cables

- Grip the body of the cable connector. Do not pull on the cable itself because this action can damage the internal wires of the cable or the pins on the port.
- If a cable does not disconnect easily, check for any release latch that must be pressed to disconnect the cable.

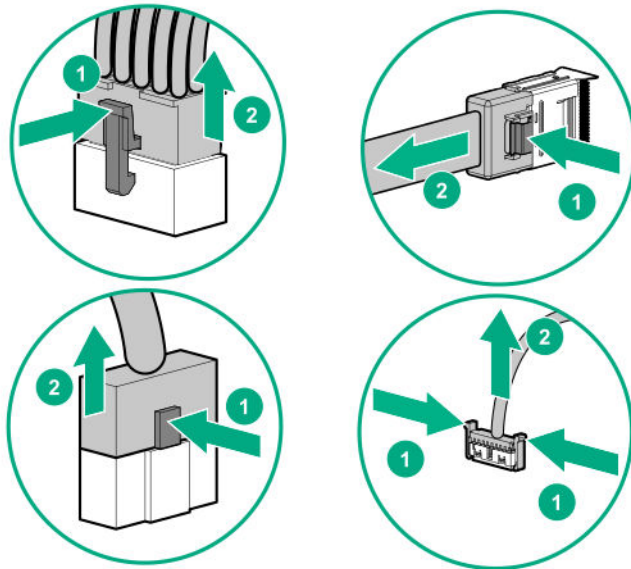

- Remove cables that are no longer being used. Retaining them inside the server can restrict airflow. If you intend to use the removed cables later, label and store them for future use.

Drive and Storage cabling

LFF non-hot-plug drive cabling

Eight bay LFF non-hot-plug drive cabling

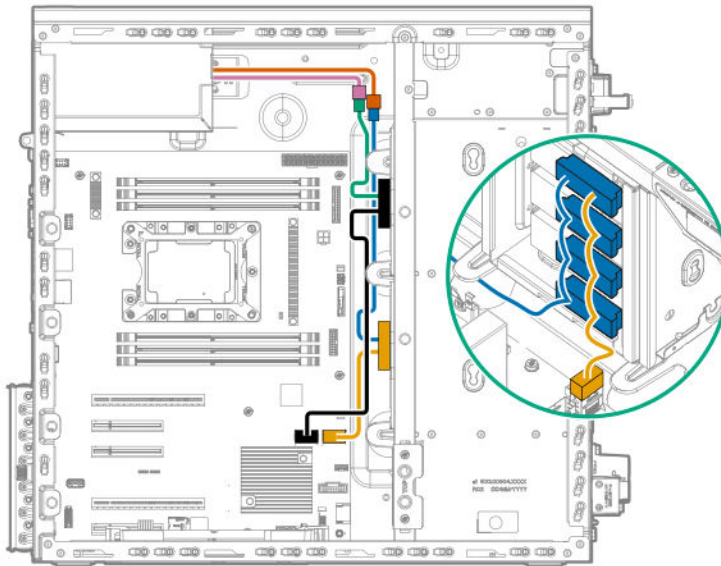

| Cable Color | Description |
|-------------|--------------------|
| Orange | Power supply cable |
| Pink | Power supply cable |

Table Continued

| Cable Color | Description |
|-------------|---|
| Green | Box 2 drive power supply cable |
| Blue | Box 1 drive power supply cable |
| Black | Box 2 non-hot-plug drive to system board x4 SATA port 2 |
| Gold | Box 1 non-hot-plug drive to system board x4 SATA port 1 |

LFF hot-plug drive cabling

Box 1 drive backplane connected to the system board

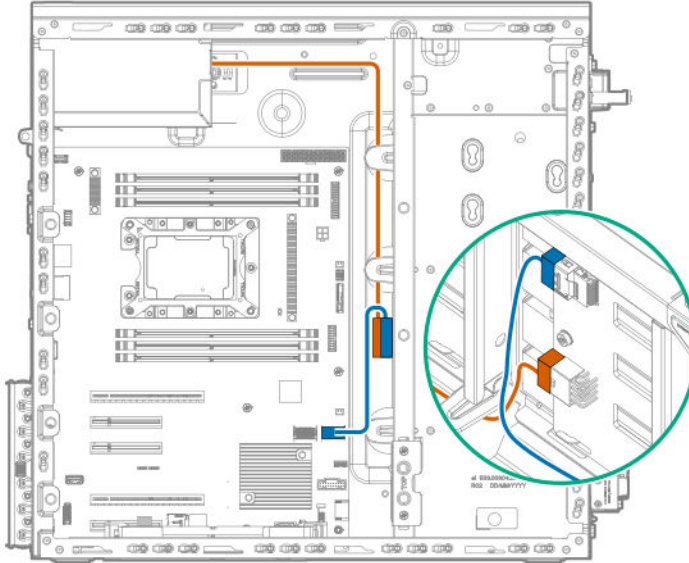

| Cable Color | Description |
|-------------|---|
| Orange | Drive power supply cable |
| Blue | Box 1 drive backplane Mini-SAS cable to system board x4 SATA port 1 |

Box 2 drive backplane connected the system board

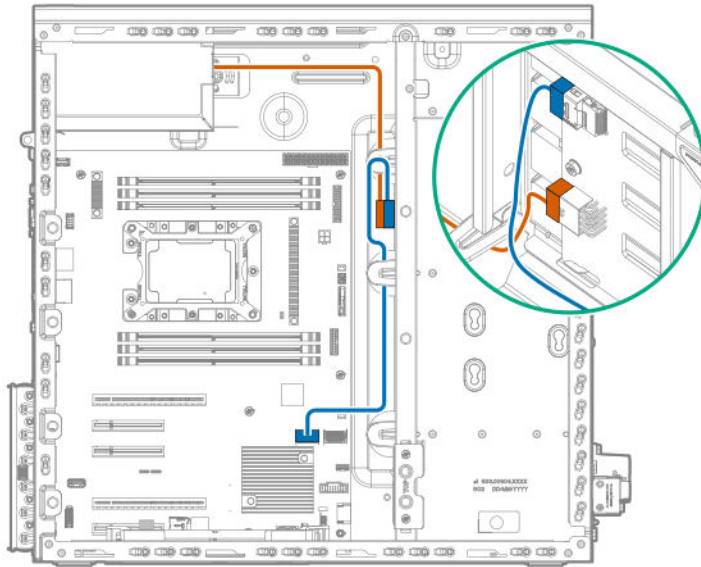

| Cable Color | Description |
|-------------|---|
| Orange | Drive power supply cable |
| Blue | Box 2 drive backplane Mini-SAS cable to system board x4 SATA port 2 |

Box 1 and Box 2 drive backplanes connected to a HBA/Smart Array controller

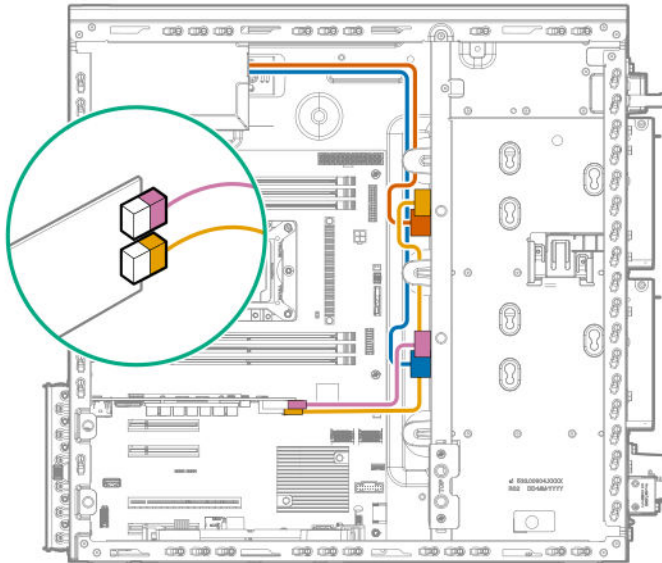

| Cable Color | Description |
|-------------|--------------------------------|
| Orange | Box 2 drive power supply cable |
| Blue | Box 1 drive power supply cable |

Table Continued

| Cable Color | Description |
|-------------|---|
| Gold | Box 2 drive backplane Mini-SAS cable to controller port 2 |
| Pink | Box 1 drive backplane Mini-SAS cable to controller port 1 |

SFF hot-plug drive cabling

Box 1 drive backplane connected to the system board

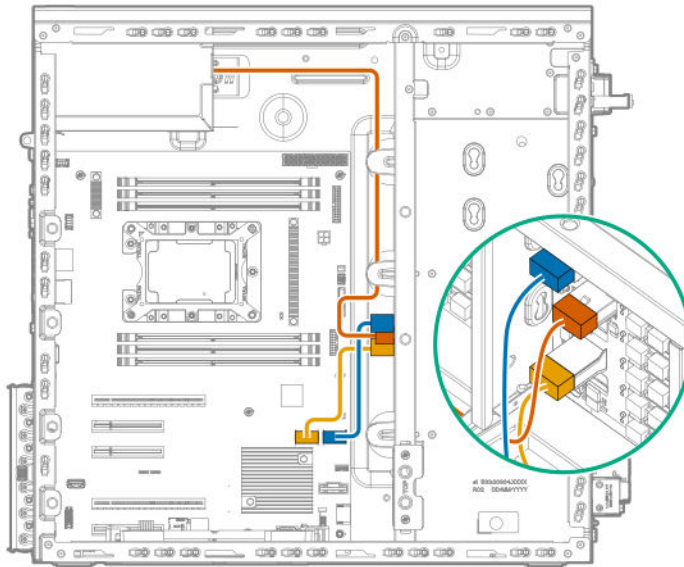

| Cable color | Description |
|-------------|--|
| Orange | Drive power supply cable |
| Blue | Box 1 drive backplane port 1 Mini-SAS cable to system board x4 SATA port 1 |
| Gold | Box 1 drive backplane port 2 Mini-SAS cable to system board x4 SATA port 2 |

Box 1 drive backplane connected to a HBA/Smart Array controller

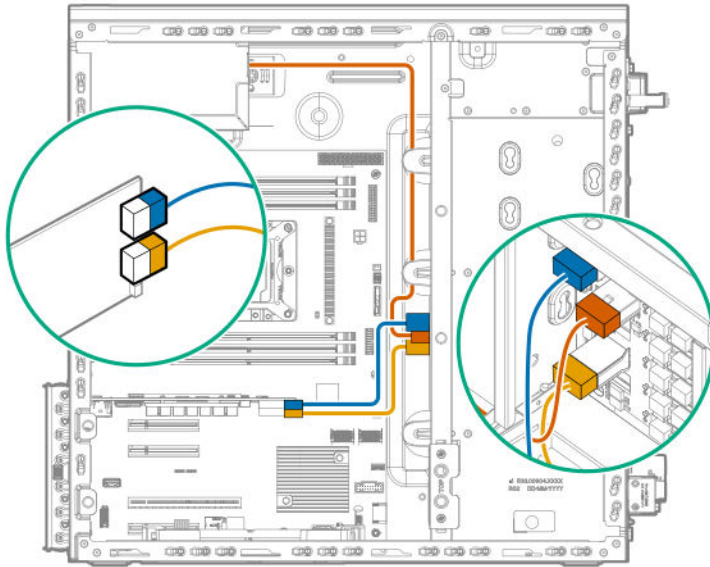

| Item | Description |
|--------|---|
| Orange | Drive power supply cable |
| Blue | Box 1 drive backplane port 1 Mini-SAS cable to type-p controller port 1 |
| Gold | Box 1 drive backplane port 2 Mini-SAS cable to type-p controller port 2 |

M.2 SSD cabling

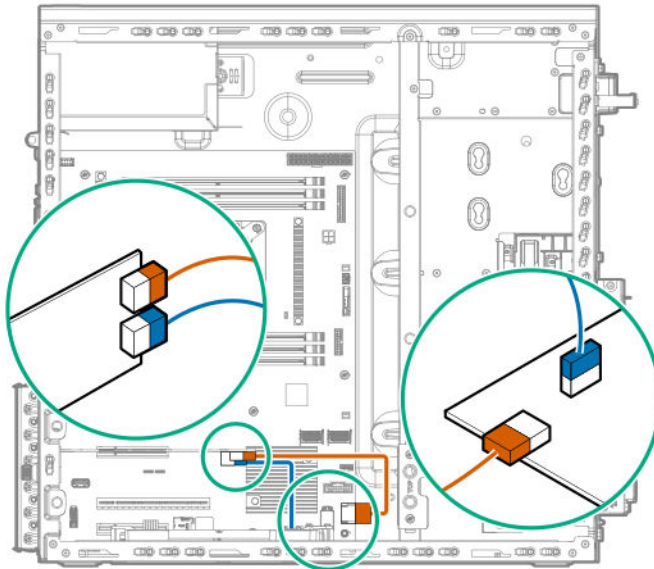

| Cable Color | Description |
|-------------|--|
| Orange | SATA cable from M.2 SSD enablement board port 1 to system board SATA port 9 |
| Blue | SATA cable from M.2 SSD enablement board port 2 to system board SATA port 10 |

Storage controller cabling

Host Bus Adapter/Smart Array controller connected to the 2x 4-bay LFF hot-plug drive cage

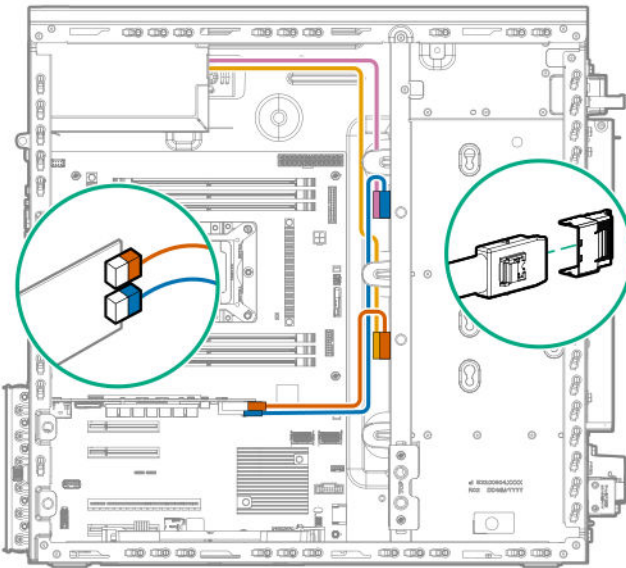

| Cable color | Description |
|-------------|--|
| Orange | Box 1 drive backplane Mini-SAS cable to type-p controller port 1 |
| Blue | Box 2 drive backplane Mini-SAS cable to type-p controller port 2 |
| Gold | Box 1 drive power supply cable |
| Pink | Box 2 drive power supply cable |

2 Host Bus Adapters/Smart Array controllers connected to the 16-bay SFF hot-plug drive cage

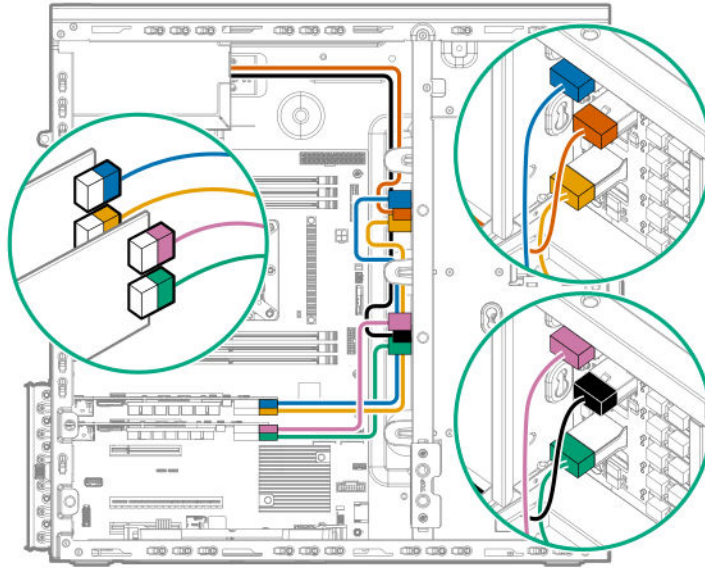

| Cable color | Description |
|-------------|--|
| Blue | Box 2 drive backplane port 1 Mini-SAS cable to slot 1 type-p controller port 1 |
| Gold | Box 2 drive backplane port 2 Mini-SAS cable to slot 1 type-p controller port 2 |
| Pink | Box 1 drive backplane port 1 Mini-SAS cable to slot 2 type-p controller port 1 |
| Green | Box 1 drive backplane port 2 Mini-SAS cable to slot 2 type-p controller port 2 |
| Black | Box 1 drive power supply cable |
| Orange | Box 2 drive power supply cable |

FBWC module cabling

The FBWC solution is a separately purchased option. This server only supports FBWC module installation when a Smart Array P-Series controller is installed.

Depending on the controller option installed, the actual storage controller connectors might look different from what is shown in this section.

FBWC module on a P408i-p controller:

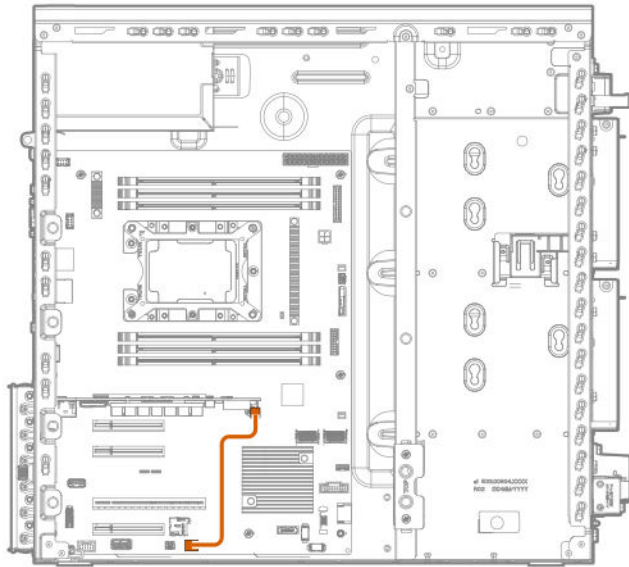

Smart Storage Battery cabling

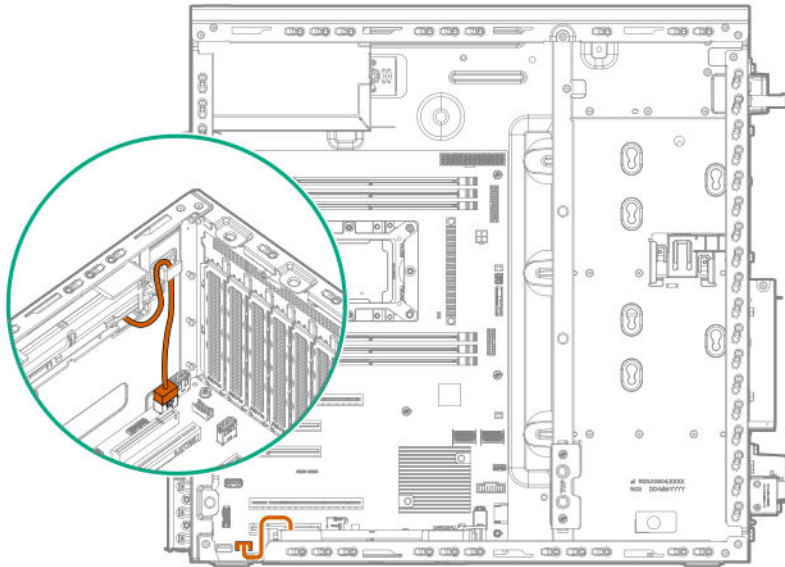

Serial port cabling

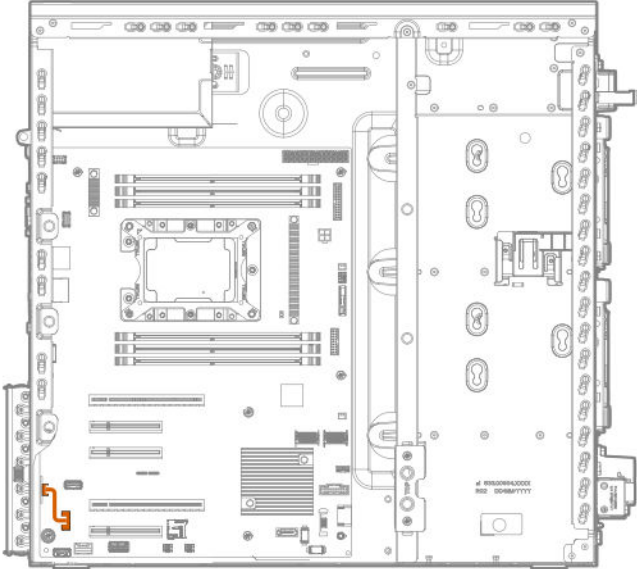

Front I/O cabling

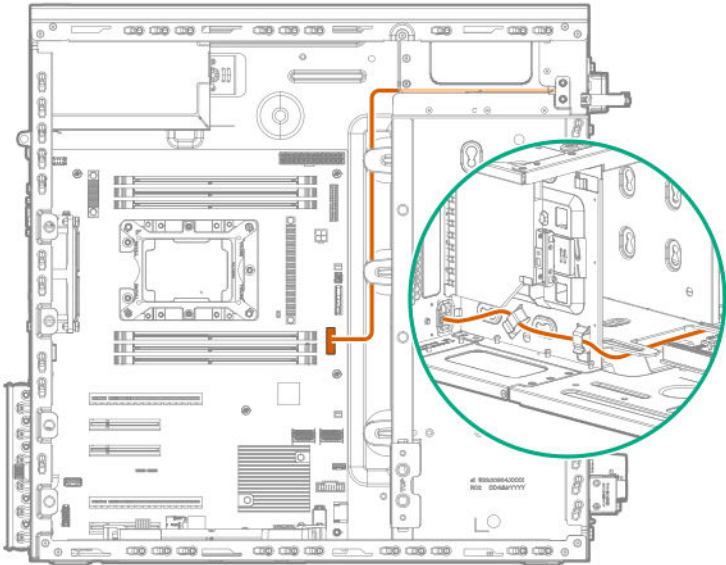

Front USB 3.0 cabling

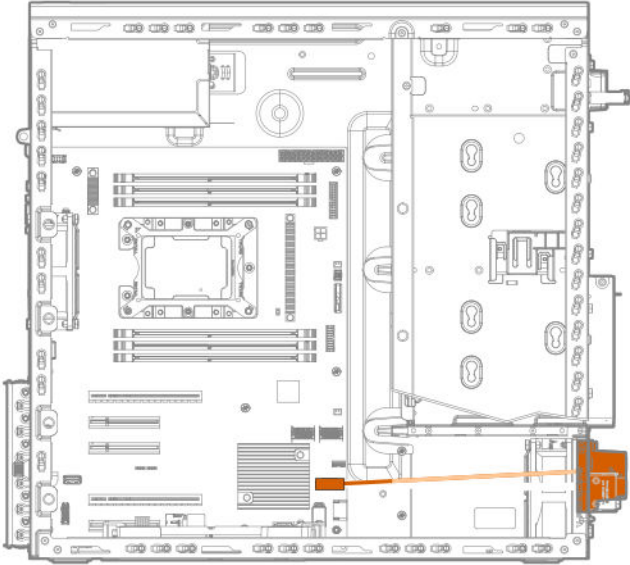

iLO service port cabling

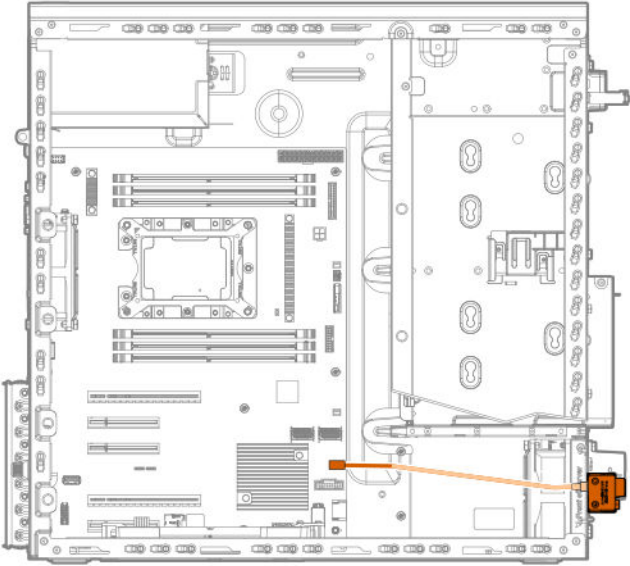

Optical drive cabling

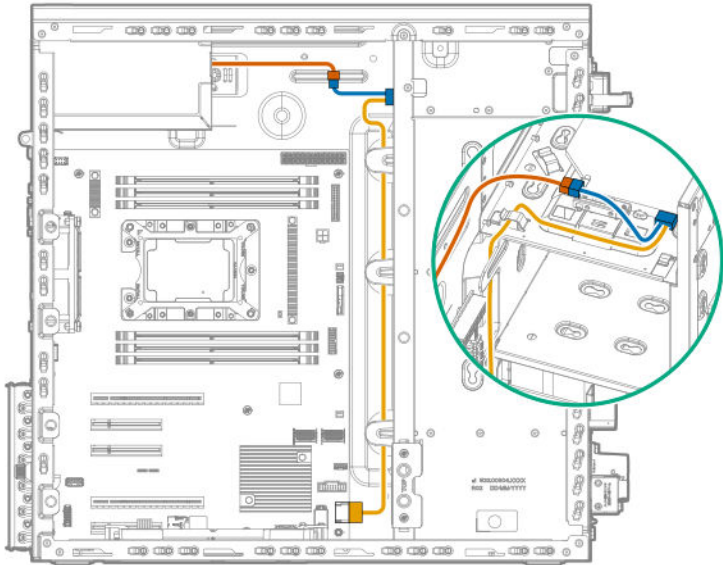

| Cable color | Description |
|-------------|--------------------------|
| Orange | Power supply cable |
| Blue | Drive power supply cable |
| Gold | SATA cable |

Fan cabling

Default system fan cabling

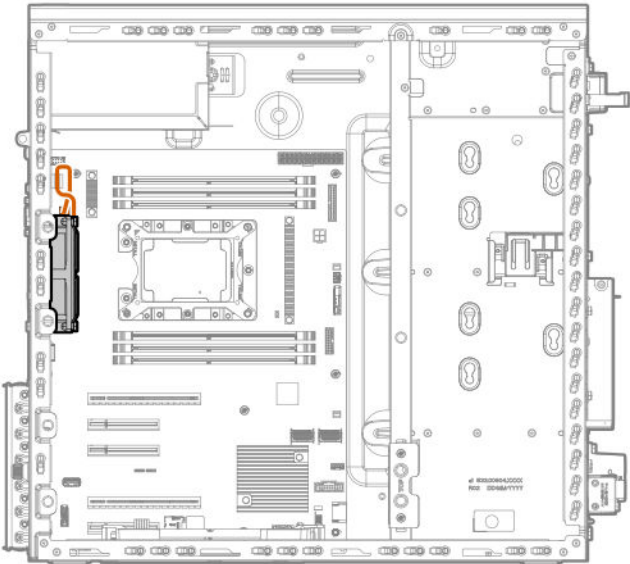

Redundant system fan cabling

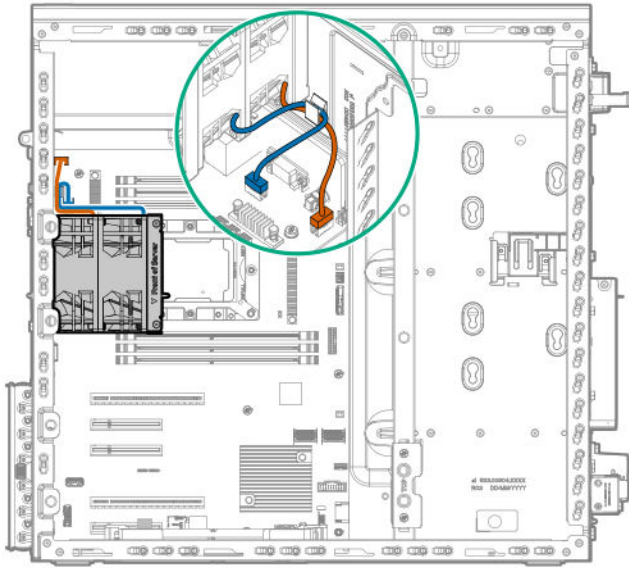

| Cable color | Description |
|-------------|-------------------------------------|
| Orange | System fan cable to fan connector 4 |
| Blue | System fan cable to fan connector 3 |

Default PCIe fan cabling

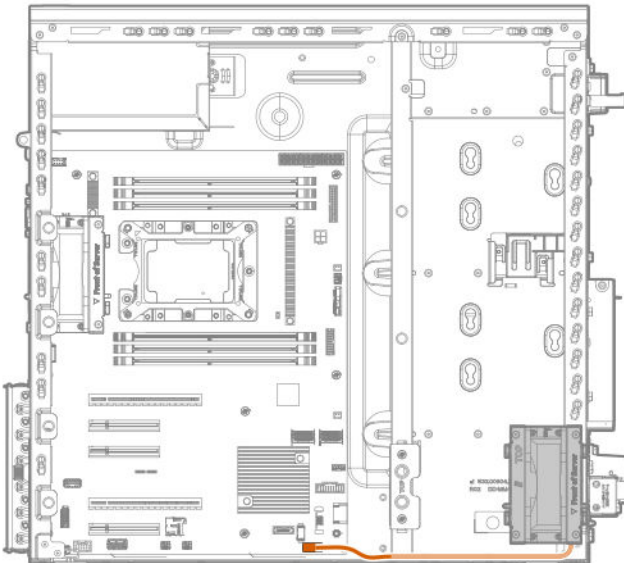

Redundant PCIe fan cabling

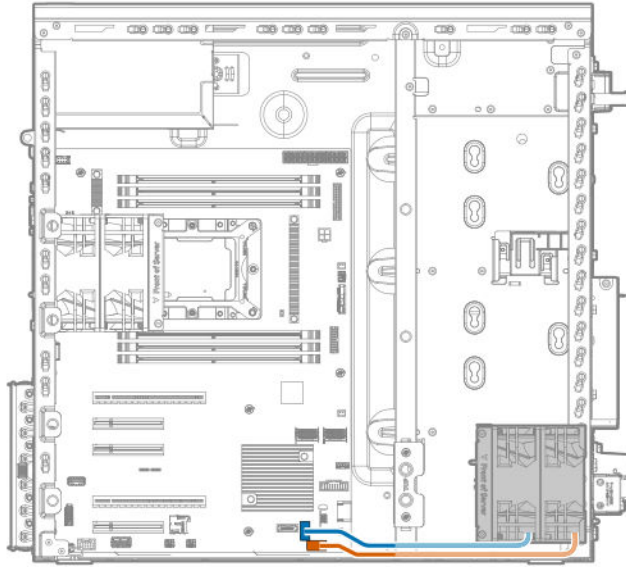

| Cable color | Description |
|-------------|-----------------------------------|
| Orange | PCIe fan cable to fan connector 1 |
| Blue | PCIe fan cable to fan connector 2 |

Power supply cabling

350W non-hot-plug power supply cabling

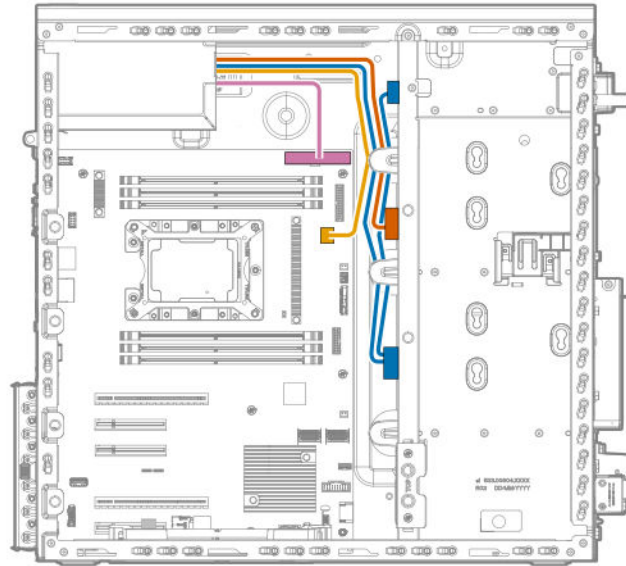

| Cable Color | Description |
|-------------|---|
| Orange | 8-pin power supply cable to box 2 drive backplane |
| Blue | 8-pin power supply cable to box 1 drive backplane and optical drive |

Table Continued

| Cable Color | Description |
|-------------|--|
| Gold | 4-pin power supply cable to system board |
| Pink | 24-pin power supply cable |

550W non-hot-plug power supply cabling

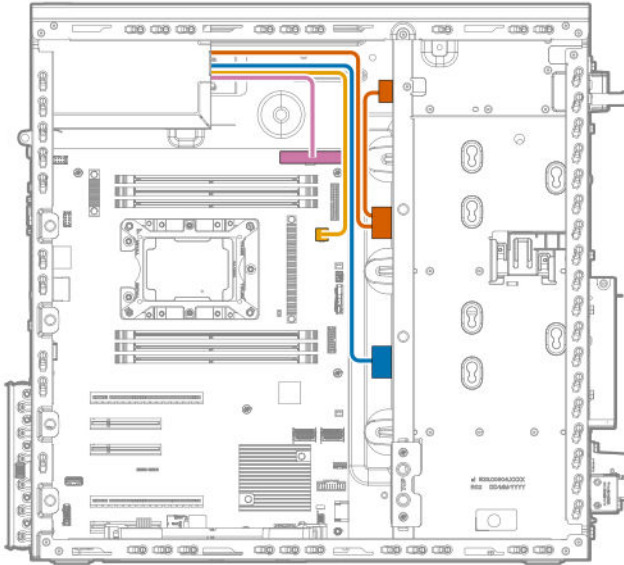

| Cable Color | Description |
|-------------|---|
| Orange | 8-pin power supply cable to box 2 drive backplane and optical drive |
| Blue | 8-pin power supply cable to box 1 drive backplane |
| Gold | 4-pin power supply cable to system board |
| Pink | 24-pin power supply cable |

Redundant power supply cabling

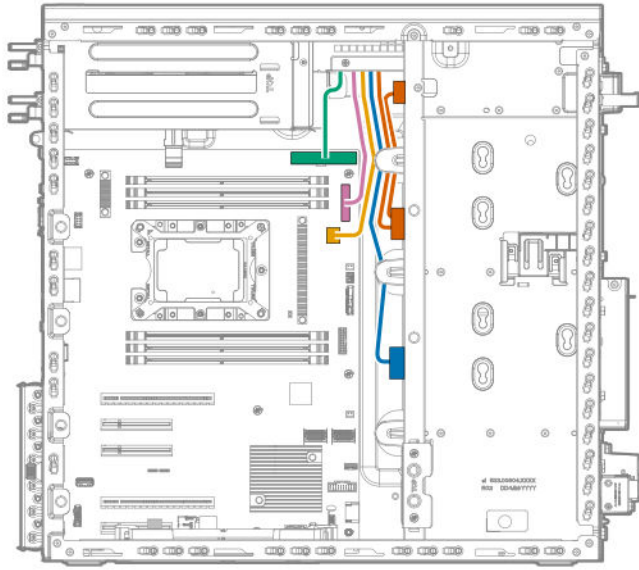

| Cable Color | Description |
|-------------|---|
| Pink | RPSU cable |
| Blue | Box 1 drive backplane power supply cable |
| Gold | 4-pin power supply cable to system board |
| Orange | Box 2 drive backplane and media bay power cable |
| Green | 24-pin power supply cable |

Specifications

Environmental specifications

| Specification | Value |
|--|---|
| Temperature range¹ | — |
| Operating | 10°C to 35°C (41°F to 104°F) |
| Nonoperating | -30°C to 60°C (-22°F to 140°F) |
| Relative humidity (noncondensing) | — |
| Operating | 8% to 90% 28°C (82.4°F), maximum wet bulb temperature |
| Nonoperating | 5% to 95% 38.7°C (101.7°F), maximum wet bulb temperature |

¹ All temperature ratings shown are for sea level. An altitude derating of 1.0°C per 305 m (1.8°F per 1000 ft) to 3050 m (10,000 ft) is applicable. No direct sunlight allowed. Maximum rate of change is 20°C per hour (36°F per hour). The upper limit and rate of change might be limited by the type and number of options installed.

For certain approved hardware configurations, the supported system inlet temperature range is extended:

- 5°C to 10°C (41°F to 50°F) and 35°C to 40°C (95°F to 104°F) at sea level with an altitude derating of 1.0°C per every 175 m (1.8°F per every 574 ft) above 900 m (2953 ft) to a maximum of 3050 m (10,000 ft)
- A redundant fan is required when the ambient temperature reaches 35°C to 40°C.

The approved hardware configurations for this system are listed on the Hewlett Packard Enterprise website (<http://www.hpe.com/servers/ASHRAE>).

Server specifications

| Dimension (with feet/bezel) | Value |
|--|---------------------|
| Height | 44.00 cm (17.32 in) |
| Depth | 48.05 cm (18.92 in) |
| Width | 19.50 cm (7.68 in) |
| Weight (approximate) | |
| Minimum (one drive, power supply, and processor installed) | 13.5 kg (29.82 lb) |
| Maximum (all drives, power supplies, and processors installed) | 25.0 kg (55.00 lb) |

Power supply specifications

Depending on the installed options and/or the regional location where the server was purchased, the server is configured with one of the following power supplies:

- ATX 350W non-hot-plug power supply
- ATX 550W non-hot-plug power supply
- HPE 800W Flex Slot Platinum Hot-plug Low Halogen Power Supply



CAUTION:

Check the system and power supply input ratings before powering up the server.

NOTE: ATX power supply will not support redundant fan option.

ATX 350W non-hot-plug power supply

| Specification | Value |
|----------------------------|--------------------------------------|
| Input requirements | |
| Rated input voltage | 100 VAC to 240 VAC |
| Rated input frequency | 50 Hz to 60 Hz |
| Rated input current | 4.5 A at 100 VAC 1.9 A at 240 VAC |
| Maximum rated input power | 437 W at 100 VAC 416 W at 240 VAC |
| BTUs per hour | 1491 at 100 VAC 1419 at 240 VAC |
| Power supply output | |
| Rated steady-state power | 350 W at 100VAC to 240VAC |
| Maximum peak power | 385 W at 100VAC to 240VAC |

ATX 550W non-hot-plug power supply

| Specification | Value |
|---------------------------|--------------------|
| Input requirements | |
| Rated input voltage | 100 VAC to 240 VAC |
| Rated input frequency | 50 Hz to 60 Hz |

Table Continued

| Specification | Value |
|----------------------------|---------------------------|
| Rated input current | 6.4 A at 100 VAC |
| | 2.62 A at 240 VAC |
| Maximum rated input power | 634 W at 100 VAC |
| | 613 W at 240 VAC |
| BTUs per hour | 1876 at 100 VAC |
| | 1876 at 240 VAC |
| Power supply output | |
| Rated steady-state power | 550 W at 100VAC to 240VAC |
| Maximum peak power | 575 W at 100VAC to 240VAC |

HPE 800W Flex Slot Platinum Hot Plug Low Halogen Power Supply

| Specification | Value |
|----------------------------|---------------------------------|
| Input requirements | |
| Rated input voltage | 100 VAC to 127 VAC |
| | 100 VAC to 240 VAC |
| | 240 VDC for China only |
| Rated input frequency | 50 Hz to 60 Hz |
| | Not applicable to 240 VDC |
| Rated input current | 9.4 A at 100 VAC |
| | 4.5 A at 200 VAC |
| | 3.8 A at 240 VDC for China only |
| Maximum rated input power | 899 W at 100 VAC |
| | 867 W at 200 VAC |
| | 864 W at 240 VDC for China only |
| BTUs per hour | 3,067 at 100 VAC |
| | 2,958 at 200 VAC |
| | 2,949 at 240 VAC for China only |
| Power supply output | |

Table Continued

| Specification | Value |
|--------------------------|---------------------------------------|
| Rated steady-state power | 800 W at 100 VAC to 127 VAC input |
| | 800 W at 100 VAC to 240 VAC input |
| | 800 W at 240 VDC input for China only |
| Maximum peak power | 800 W at 100 VAC to 127 VAC input |
| | 800 W at 100 VAC to 240 VAC input |
| | 800 W at 240 VDC input for China only |

Hot-plug power supply calculations

For hot-plug power supply specifications and calculators to determine electrical and heat loading for the server, see the Hewlett Packard Enterprise Power Advisor website (<http://www.hpe.com/info/poweradvisor/online>).

Safety, warranty, and regulatory information

Safety and regulatory compliance

For important safety, environmental, and regulatory information, see *Safety and Compliance Information for Server, Storage, Power, Networking, and Rack Products*, available at the Hewlett Packard Enterprise website (<http://www.hpe.com/support/Safety-Compliance-EnterpriseProducts>).

Warranty information

[HPE ProLiant and x86 Servers and Options](#)

[HPE Enterprise Servers](#)

[HPE Storage Products](#)

[HPE Networking Products](#)

Belarus Kazakhstan Russia marking



Manufacturer and Local Representative Information

Manufacturer information:

Hewlett Packard Enterprise Company, 3000 Hanover Street, Palo Alto, CA 94304 U.S.

Local representative information Russian:

- Russia:

ООО «Хьюлетт Паккард Энтерпрайз», Российская Федерация, 125171, г. Москва, Ленинградское шоссе, 16А, стр.3, Телефон/факс: +7 495 797 35 00

- Belarus:

ИООО «Хьюлетт-Паккард Бел», Республика Беларусь, 220030, г. Минск, ул. Интернациональная, 36-1, Телефон/факс: +375 17 392 28 20

- Kazakhstan:

ТОО «Хьюлетт-Паккард (К)», Республика Казахстан, 050040, г. Алматы, Бостандыкский район, проспект Аль-Фараби, 77/7, Телефон/факс: + 7 727 355 35 52

Local representative information Kazakh:

- Russia:

ЖШС "Хьюлетт Паккард Энтерпрайз", Ресей Федерациясы, 125171,
Мәскеу, Ленинград тас жолы, 16А блок 3, Телефон/факс: +7 495 797 35 00

- Belarus:

«HEWLETT-PACKARD Bel» ЖШС, Беларусь Республикасы, 220030, Минск қ.,
Интернациональная көшесі, 36/1, Телефон/факс: +375 17 392 28 20

- Kazakhstan:

ЖШС «Хьюлетт-Паккард (К)», Қазақстан Республикасы, 050040, Алматы қ.,
Бостандық ауданы, Әл-Фараби даңғылы, 77/7, Телефон/факс: +7 727 355 35 52

Manufacturing date:

The manufacturing date is defined by the serial number.

CCSYWWZZZZ (serial number format for this product)

Valid date formats include:

- YWW, where Y indicates the year counting from within each new decade, with 2000 as the starting point; for example, 238: 2 for 2002 and 38 for the week of September 9. In addition, 2010 is indicated by 0, 2011 by 1, 2012 by 2, 2013 by 3, and so forth.
- YYWW, where YY indicates the year, using a base year of 2000; for example, 0238: 02 for 2002 and 38 for the week of September 9.

Turkey RoHS material content declaration

Türkiye Cumhuriyeti: EEE Yönetmeliğine Uygundur

Ukraine RoHS material content declaration

Обладнання відповідає вимогам Технічного регламенту щодо обмеження використання деяких небезпечних речовин в електричному та електронному обладнанні, затвердженого постановою Кабінету Міністрів України від 3 грудня 2008 № 1057

Websites

General websites

Hewlett Packard Enterprise Information Library

www.hpe.com/info/EIL

Subscription Service/Support Alerts

www.hpe.com/support/e-updates

Single Point of Connectivity Knowledge (SPOCK) Storage compatibility matrix

www.hpe.com/storage/spock

Storage white papers and analyst reports

www.hpe.com/storage/whitepapers

For additional general support websites, see [Support and other resources](#).

Product websites

Product QuickSpecs

<http://www.hpe.com/servers/ml110-gen10>

HPE ProLiant ML110 Gen10 support page

<http://www.hpe.com/support/ml110gen10>

HPE ProLiant ML110 Gen10 documents

<http://www.hpe.com/info/ml110gen10-docs>

Support and other resources

Accessing Hewlett Packard Enterprise Support

- For live assistance, go to the Contact Hewlett Packard Enterprise Worldwide website:
<http://www.hpe.com/assistance>
- To access documentation and support services, go to the Hewlett Packard Enterprise Support Center website:
<http://www.hpe.com/support/hpesc>

Information to collect

- Technical support registration number (if applicable)
- Product name, model or version, and serial number
- Operating system name and version
- Firmware version
- Error messages
- Product-specific reports and logs
- Add-on products or components
- Third-party products or components

Accessing updates

- Some software products provide a mechanism for accessing software updates through the product interface. Review your product documentation to identify the recommended software update method.
- To download product updates:

Hewlett Packard Enterprise Support Center

www.hpe.com/support/hpesc

Hewlett Packard Enterprise Support Center: Software downloads

www.hpe.com/support/downloads

Software Depot

www.hpe.com/support/softwaredepot

- To subscribe to eNewsletters and alerts:
www.hpe.com/support/e-updates
- To view and update your entitlements, and to link your contracts and warranties with your profile, go to the Hewlett Packard Enterprise Support Center **More Information on Access to Support Materials** page:

❗ **IMPORTANT:**

Access to some updates might require product entitlement when accessed through the Hewlett Packard Enterprise Support Center. You must have an HPE Passport set up with relevant entitlements.

Customer self repair

Hewlett Packard Enterprise customer self repair (CSR) programs allow you to repair your product. If a CSR part needs to be replaced, it will be shipped directly to you so that you can install it at your convenience. Some parts do not qualify for CSR. Your Hewlett Packard Enterprise authorized service provider will determine whether a repair can be accomplished by CSR.

For more information about CSR, contact your local service provider or go to the CSR website:

<http://www.hpe.com/support/selfrepair>

Remote support

Remote support is available with supported devices as part of your warranty or contractual support agreement. It provides intelligent event diagnosis, and automatic, secure submission of hardware event notifications to Hewlett Packard Enterprise, which will initiate a fast and accurate resolution based on your product's service level. Hewlett Packard Enterprise strongly recommends that you register your device for remote support.

If your product includes additional remote support details, use search to locate that information.

Remote support and Proactive Care information

HPE Get Connected

www.hpe.com/services/getconnected

HPE Proactive Care services

www.hpe.com/services/proactivecare

HPE Proactive Care service: Supported products list

www.hpe.com/services/proactivecaresupportedproducts

HPE Proactive Care advanced service: Supported products list

www.hpe.com/services/proactivecareadvancedsupportedproducts

Proactive Care customer information

Proactive Care central

www.hpe.com/services/proactivecarecentral

Proactive Care service activation

www.hpe.com/services/proactivecarecentralgetstarted

Documentation feedback

Hewlett Packard Enterprise is committed to providing documentation that meets your needs. To help us improve the documentation, send any errors, suggestions, or comments to Documentation Feedback (docsfeedback@hpe.com). When submitting your feedback, include the document title, part number, edition, and publication date located on the front cover of the document. For online help content, include the product name, product version, help edition, and publication date located on the legal notices page.