



ideacentre Y710 Hardware Maintenance Manual

Machine Types:90FL [Y710 Cube-15ISH/Energy Star] / 90FM [Y710
Cube-15ISH/None Energy Star]



ideacentre Y710 Hardware Maintenance Manual

Machine Types:90FL [Y710 Cube-15ISH/Energy Star] / 90FM [Y710
Cube-15ISH/None Energy Star]

First Edition (July 2016)4th

© Copyright Lenovo 2016.

LIMITED AND RESTRICTED RIGHTS NOTICE: If data or software are delivered pursuant a General Services Administration "GSA" contract, use, reproduction, or disclosure is subject to restrictions set forth in Contract No. GS-35F-05925

Contents

Chapter 1. About this manual	1	Undetermined problems	20
Important Safety Information	1	Chapter 7. Locations	23
Chapter 2. Safety information	3	Identifying internal components	23
General safety	3	Identifying parts on the system board.	25
Electrical safety	3	Chapter 8. Replacing hardware	27
Safety inspection guide	5	General information.	27
Handling electrostatic discharge-sensitive devices	5	Replacing the keyboard and mouse	28
Grounding requirements	6	Removing the computer cover	28
Safety notices	6	Removing the computer cover(Lenovo logo)	29
Chapter 3. General information	9	Removing the top cover	30
Specifications	9	Removing the bottom cover	32
Chapter 4. General Checkout	11	Removing the front bezel	33
Chapter 5. Using the Setup Utility.	13	Replacing the xbox dongle	34
Starting the Lenovo BIOS Setup Utility program	13	Replacing a memory module	36
Viewing and changing settings	13	Replacing a hard disk drive.	37
Using passwords.	13	Replacing a solid state drive	38
Enabling or disabling a device	15	Replacing the heat-sink assembly	41
Selecting a startup device	16	Replacing the Wi-Fi card.	43
Exiting the Lenovo BIOS Setup Utility program	17	Replacing a graphics card	44
Chapter 6. Symptom-to-FRU Index	19	Replacing the CPU	47
Hard disk drive boot error	19	Replacing the Power supply	49
Power Supply Problems	19	Replacing the motherboard.	52
Additional Service Information	19	Replacing the front I/O module	53
POST error codes	20	FRU lists	54
		Chapter 9. General information	61
		Additional Service Information	61

Chapter 1. About this manual

This manual contains service and reference information for ideacentre Y710 desktop computers listed on the cover. It is intended only for trained servicers who are familiar with Lenovo computer products.

Before servicing a Lenovo product, be sure to read the Safety Information.

The description of the TV card in this manual is only used for the machines which have the TV card. It is invalid for those machines which do not have TV card.

Important Safety Information

Important: System requirement warning terms for Y710

Your thermal equipment **MUST** be consistent with your own clock frequency and/or voltage settings.

Important: Lenovo's warranty warning terms for Y900

Altering the default setting of any item in this sub-menu may: (i) reduce system stability and useful life of the system, processor, and other system components; (ii) cause the processor and other system components to fail; (iii) cause reductions in system performance; (iv) cause additional heat or other damage; and (v) affect system data integrity.

Lenovo and Intel have not tested, and do not warranty, the operation of the processor beyond its specifications. Lenovo and Intel have not tested, and do not warranty, the operation of other system components beyond their industry standard specifications.

Lenovo and Intel assume no responsibility that the processor and other system components, including if used with altered clock frequencies, voltages, and/or any other operation parameters will be fit for any particular purpose.

Be sure to read all caution and danger statements in this book before performing any of the instructions.

Veillez lire toutes les consignes de type DANGER et ATTENTION du présent document avant d'exécuter les instructions.

Lesen Sie unbedingt alle Hinweise vom Typ "ACHTUNG" oder "VORSICHT" in dieser Dokumentation, bevor Sie irgendwelche Vorgänge durchführen

Leggere le istruzioni introdotte da ATTENZIONE e PERICOLO presenti nel manuale prima di eseguire una qualsiasi delle istruzioni

Certifique-se de ler todas as instruções de cuidado e perigo neste manual antes de executar qualquer uma das instruções

Es importante que lea todas las declaraciones de precaución y de peligro de este manual antes de seguir las instrucciones.

执行任何说明之前，请确保已阅读本书中的所有警告和危险声明。

執行任何指示前，請確實閱讀本書中的所有警告及危險聲明。

Chapter 2. Safety information

This chapter contains the safety information that you need to be familiar with before servicing a computer.

General safety

Follow these rules to ensure general safety:

- Observe good housekeeping in the area of the machines during and after maintenance.
- When lifting any heavy object:
 1. Ensure you can stand safely without slipping.
 2. Distribute the weight of the object equally between your feet.
 3. Use a slow lifting force. Never move suddenly or twist when you attempt to lift.
 4. Lift by standing or by pushing up with your leg muscles; this action removes the strain from the muscles in your back.
Do not attempt to lift any objects that weigh more than 16 kg (35 lb) or objects that you think are too heavy for you.
- Do not perform any action that causes hazards to the customer, or that makes the equipment unsafe.
- Before you start the machine, ensure that other service representatives and the customer's personnel are not in a hazardous position.
- Place removed covers and other parts in a safe place, away from all personnel, while you are servicing the machine.
- Keep your tool case away from walk areas so that other people will not trip over it.
- Do not wear loose clothing that can be trapped in the moving parts of a machine. Ensure that your sleeves are fastened or rolled up above your elbows. If your hair is long, fasten it.
- Insert the ends of your necktie or scarf inside clothing or fasten it with a nonconductive clip, approximately 8 centimeters (3 inches) from the end.
- Do not wear jewelry, chains, metal-frame eyeglasses, or metal fasteners for your clothing.
Remember: Metal objects are good electrical conductors.
- Wear safety glasses when you are: hammering, drilling soldering, cutting wire, attaching springs, using solvents, or working in any other conditions that might be hazardous to your eyes.
- After service, reinstall all safety shields, guards, labels, and ground wires. Replace any safety device that is worn or defective.
- Reinstall all covers correctly before returning the machine to the customer.

Electrical safety



CAUTION:

Electrical current from power, telephone, and communication cables can be hazardous. To avoid personal injury or equipment damage, disconnect the attached power cords, telecommunication systems, networks, and modems before you open the computer covers, unless instructed otherwise in the installation and configuration procedures.

Observe the following rules when working on electrical equipment.

Important: Use only approved tools and test equipment. Some hand tools have handles covered with a soft material that does not insulate you when working with live electrical currents. Many customers have, near their equipment, rubber floor mats that contain small conductive fibers to decrease electrostatic discharges. Do not use this type of mat to protect yourself from electrical shock.

- Find the room emergency power-off (EPO) switch, disconnecting switch, or electrical outlet. If an electrical accident occurs, you can then operate the switch or unplug the power cord quickly.
- Do not work alone under hazardous conditions or near equipment that has hazardous voltages.
- Disconnect all power before:
 - Performing a mechanical inspection
 - Working near power supplies
 - Removing or installing Field Replaceable Units (FRUs)
- Before you start to work on the machine, unplug the power cord. If you cannot unplug it, ask the customer to power-off the wall box that supplies power to the machine and to lock the wall box in the off position.
- If you need to work on a machine that has exposed electrical circuits, observe the following precautions:
 - Ensure that another person, familiar with the power-off controls, is near you.
Remember: Another person must be there to switch off the power, if necessary.
 - Use only one hand when working with powered-on electrical equipment; keep the other hand in your pocket or behind your back.
Remember: There must be a complete circuit to cause electrical shock. By observing the above rule, you may prevent a current from passing through your body.
 - When using a tester, set the controls correctly and use the approved probe leads and accessories for that tester.
 - Stand on suitable rubber mats (obtained locally, if necessary) to insulate you from grounds such as metal floor strips and machine frames.

Observe the special safety precautions when you work with very high voltages; these instructions are in the safety sections of maintenance information. Use extreme care when measuring high voltages.

- Regularly inspect and maintain your electrical hand tools for safe operational condition.
- Do not use worn or broken tools and testers.
- *Never assume* that power has been disconnected from a circuit. First, *check* that it has been powered-off.
- Always look carefully for possible hazards in your work area. Examples of these hazards are moist floors, nongrounded power extension cables, power surges, and missing safety grounds.
- Do not touch live electrical circuits with the reflective surface of a plastic dental mirror. The surface is conductive; such touching can cause personal injury and machine damage.
- Do not service the following parts with the power on when they are removed from their normal operating places in a machine:
 - Power supply units
 - Pumps
 - Blowers and fans
 - Motor generatorsand similar units. (This practice ensures correct grounding of the units.)
- If an electrical accident occurs:
 - Use caution; do not become a victim yourself.
 - Switch off power.

- Send another person to get medical aid.

Safety inspection guide

The intent of this inspection guide is to assist you in identifying potentially unsafe conditions on these products. Each machine, as it was designed and built, had required safety items installed to protect users and service personnel from injury. This guide addresses only those items. However, good judgment should be used to identify potential safety hazards due to attachment of features or options not covered by this inspection guide.

If any unsafe conditions are present, you must determine how serious the apparent hazard could be and whether you can continue without first correcting the problem.

Consider these conditions and the safety hazards they present:

- Electrical hazards, especially primary power (primary voltage on the frame can cause serious or fatal electrical shock).
- Explosive hazards, such as a damaged CRT face or bulging capacitor
- Mechanical hazards, such as loose or missing hardware

The guide consists of a series of steps presented in a checklist. Begin the checks with the power off, and the power cord disconnected.

Checklist:

1. Check exterior covers for damage (loose, broken, or sharp edges).
2. Power-off the computer. Disconnect the power cord.
3. Check the power cord for:
 - a. A third-wire ground connector in good condition. Use a meter to measure third-wire ground continuity for 0.1 ohm or less between the external ground pin and frame ground.
 - b. The power cord should be the appropriate type as specified in the parts listings.
 - c. Insulation must not be frayed or worn.
4. Remove the cover.
5. Check for any obvious alterations. Use good judgment as to the safety of any alterations.
6. Check inside the unit for any obvious unsafe conditions, such as metal filings, contamination, water or other liquids, or signs of fire or smoke damage.
7. Check for worn, frayed, or pinched cables.
8. Check that the power-supply cover fasteners (screws or rivets) have not been removed or tampered with.

Handling electrostatic discharge-sensitive devices

Any computer part containing transistors or integrated circuits (ICs) should be considered sensitive to electrostatic discharge (ESD). ESD damage can occur when there is a difference in charge between objects. Protect against ESD damage by equalizing the charge so that the machine, the part, the work mat, and the person handling the part are all at the same charge.

Notes:

1. Use product-specific ESD procedures when they exceed the requirements noted here.
2. Make sure that the ESD protective devices you use have been certified (ISO 9000) as fully effective.

When handling ESD-sensitive parts:

- Keep the parts in protective packages until they are inserted into the product.

- Avoid contact with other people while handling the part.
- Wear a grounded wrist strap against your skin to eliminate static on your body.
- Prevent the part from touching your clothing. Most clothing is insulative and retains a charge even when you are wearing a wrist strap.
- Use the black side of a grounded work mat to provide a static-free work surface. The mat is especially useful when handling ESD-sensitive devices.
- Select a grounding system, such as those listed below, to provide protection that meets the specific service requirement.

Note: The use of a grounding system is desirable but not required to protect against ESD damage.

- Attach the ESD ground clip to any frame ground, ground braid, or green-wire ground.
- Use an ESD common ground or reference point when working on a double-insulated or battery-operated system. You can use coax or connector-outside shells on these systems.
- Use the round ground-prong of the ac plug on ac-operated computers.

Grounding requirements

Electrical grounding of the computer is required for operator safety and correct system function. Proper grounding of the electrical outlet can be verified by a certified electrician.

Safety notices

The caution and danger safety notices in this section are provided in the the language of English.



DANGER

Electrical current from power, telephone and communication cables is hazardous.

To avoid a shock hazard:

- **Do not connect or disconnect any cables or perform installation, maintenance, or reconfiguration of this product during an electrical storm.**
- **Connect all power cords to a properly wired and grounded electrical outlet.**
- **Connect to properly wired outlets any equipment that will be attached to this product.**
- **When possible, use one hand only to connect or disconnect signal cables.**
- **Never turn on any equipment when there is evidence of fire, water, or structural damage.**
- **Disconnect the attached power cords, telecommunications systems, networks, and modems before you open the device covers, unless instructed otherwise in the installation and configuration procedures.**
- **Connect and disconnect cables as described in the following table when installing, moving, or opening covers on this product or attached devices.**

To Connect	To Disconnect
<ol style="list-style-type: none"> 1. Turn everything OFF. 2. First, attach all cables to devices. 3. Attach signal cables to connectors. 4. Attach power cords to outlet. 5. Turn device ON. 	<ol style="list-style-type: none"> 1. Turn everything OFF. 2. First, remove power cords from outlet. 3. Remove signal cables from connectors. 4. Remove all cables from devices.



CAUTION:

When replacing the lithium battery, use only Part Number 45C1566 or an equivalent type battery recommended by the manufacturer. If your system has a module containing a lithium battery, replace it only with the same module type made by the same manufacturer. The battery contains lithium and can explode if not properly used, handled, or disposed of.

Do not:

- Throw or immerse into water
- Heat to more than 100°C (212°F)
- Repair or disassemble

Dispose of the battery as required by local ordinances or regulations.



CAUTION:

When laser products (such as CD-ROMs, DVD-ROM drives, fiber optic devices, or transmitters) are installed, note the following:

- Do not remove the covers. Removing the covers of the laser product could result in exposure to hazardous laser radiation. There are no serviceable parts inside the device.
- Use of controls or adjustments or performance of procedures other than those specified herein might result in hazardous radiation exposure.





 **DANGER**

Some laser products contain an embedded Class 3A or Class 3B laser diode. Note the following:

Laser radiation when open. Do not stare into the beam, do not view directly with optical instruments, and avoid direct exposure to the beam.



		
≥18 kg(37 lbs)	≥32 kg(70.5 lbs)	≥55 kg(121.2 lbs)

CAUTION:
Use safe practices when lifting.



CAUTION:
The power control button on the device and the power switch on the power supply do not turn off the electrical current supplied to the device. The device also might have more than one power cord. To remove all electrical current from the device, ensure that all power cords are disconnected from the power source.

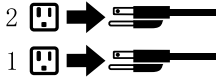

CAUTION:
Do not place any object weighing more than 82 kg (180 lbs.) on top of rack-mounted devices.



Chapter 3. General information

This chapter provides general information that applies to all machine types supported by this publication.

Specifications

This section lists the physical specifications for your computer.

This section lists the physical specifications for your computer.

Type ideacentre Y710

This section lists the physical specifications.

Environment

Air temperature:

Operating: 10° to 35°C

Transit: -20° to 55°C

Humidity:

Operating: 35% to 80%

Transit: 20% to 90% (40°C)

Altitude: 86KPa to 106KPa

Electrical input:

Input voltage: 90V-264V(AC)

Input frequency: 47Hz-63Hz

Chapter 4. General Checkout

Attention: The drives in the computer you are servicing might have been rearranged or the drive startup sequence changed. Be extremely careful during write operations such as copying, saving, or formatting. Data or programs can be overwritten if you select an incorrect drive.

General error messages appear if a problem or conflict is found by an application program, the operating system, or both. For an explanation of these messages, refer to the information supplied with that software package.

Use the following procedure to help determine the cause of the problem:

1. Power-off the computer and all external devices.
2. Check all cables and power cords.
3. Set all display controls to the middle position.
4. Power-on all external devices.
5. Power-on the computer.
 - Look for displayed error codes
 - Look for readable instructions or a main menu on the display.

If you did not receive the correct response, proceed to step 6.

If you do receive the correct response, proceed to step 7.

6. Look at the following conditions and follow the instructions:
 - If the computer displays a POST error, go to “POST error codes”.
 - If the computer hangs and no error is displayed, continue at step 7.
7. If the test stops and you cannot continue, replace the last device tested.

Chapter 5. Using the Setup Utility

The Setup Utility program is used to view and change the configuration settings of your computer, regardless of which operating system you are using. However, the operating-system settings might override any similar settings in the Setup Utility program.

Starting the Lenovo BIOS Setup Utility program

To start the Lenovo BIOS Setup Utility program, do the following:

1. If your computer is already on when you start this procedure, shut down the operating system and turn off the computer.
2. Press and hold the **F1** key then turn on the computer. When the Lenovo BIOS Setup Utility program is displayed, release the **F1** key.

Note: If a Power-On Password or an Administrator Password has been set, the Setup Utility program menu is not displayed until you type your password. For more information, see “Using passwords.”

Viewing and changing settings

System configuration options are listed in the Lenovo BIOS Setup Utility program menu. To view or change settings, see “Starting the Setup Utility program.”

You must use the keyboard when using the Lenovo BIOS Setup Utility menu. The keys used to perform various tasks are displayed on the bottom of each screen.

Using passwords

You can use the Lenovo BIOS Setup Utility program to set passwords to prevent unauthorized persons from gaining access to your computer and data. See “Starting the Setup Utility program.” The following types of passwords are available:

- Set Administrator Password
- Set Power-On Password

You do not have to set any passwords to use your computer. However, if you decide to set passwords, read the following sections.

Password considerations

A password can be any combination of letters and numbers up to 16 character (a-z, and 0-9). For security reasons, it is a good idea to use a strong password that cannot be easily compromised. We suggest that passwords should follow these rules:

- Strong passwords contain 7-16 characters, combine letters and numbers.
- Do not use your name or your user name.
- Do not use a common word or a common name.
- Be significantly different from your previous password.

Attention: Administrator and Power-On passwords are not case sensitive

Administrator Password

Setting an Administrator Password deters unauthorized persons from changing configuration settings. You might want to set an Administrator Password if you are responsible for maintaining the settings of several computers.

After you set an Administrator Password, a password prompt is displayed every time you access the Lenovo BIOS Setup Utility program.

If both the Administrator and Power-On Password are set, you can type either password. However, you must use your Administrator Password to change any configuration settings.

Setting, changing, or deleting an Administrator password

To set an Administrator Password, do the following:

Note: A password can be any combination of letters and numbers up to 16 character (a-z, and 0-9). For more information, see “Password considerations” on page 13.

1. Start the Lenovo BIOS Setup Utility program (see “Starting the Lenovo BIOS Setup Utility program” on page 13).
2. From the **Security** menu, select **Set Administrator Password** and press the **Enter** key.
3. The password dialog box will be displayed. Type the password then press the **Enter** key.
4. Re-type the password to confirm, then press the **Enter** key. If you type the password correctly, the password will be installed.

To change an Administrator Password, do the following:

1. Start the Lenovo BIOS Setup Utility program (see “Starting the Lenovo BIOS Setup Utility program” on page 13).
2. From the **Security** menu, select **Set Administrator Password** and press the **Enter** key.
3. The password dialog box will be displayed. Type the current password then press **Enter** key.
4. Type the new password, then press **Enter** key. Re-type the password to confirm the new password, if you type the new password correctly, the new password will be installed. A Setup Notice will display that changes have been saved.

To delete a previously set Administrator Password, do the following :

1. From the **Security** menu, select **Set Administrator Password** and press the **Enter** key.
2. The password dialog box will be displayed. Type the current password and press the **Enter** key.
3. To delete an **Administrator Password**, **Enter** blank fields for each new password line item. A setup notice will display that changes have been saved.
4. Return to the Lenovo BIOS Setup Utility program menu and select the **Exit** option.
5. Select **Save changes and Exit** from the menu.

Power-On Password

When a Power-On Password is set, you cannot start the Lenovo BIOS Setup Utility program until a valid password is typed from the keyboard.

Setting, changing, or deleting a Power-On Password

Note: A password can be any combination of letters and numbers up to 16 character (a-z, and 0-9).

To set a Power-On Password, do the following:

1. Start the Lenovo BIOS Setup Utility program (See "Starting the Lenovo BIOS Setup Utility program" on page 13.)
2. From the **Security** menu, select **Set Power-On Password** and press the **Enter** key.
3. The password dialog box will be displayed. Type the password, and press the **Enter** key.
4. Re-type the password to confirm, if you type the password correctly, the password will be installed.

To change a Power-On Password, do the following:

1. Start the Lenovo BIOS Setup Utility program (See "Starting the Lenovo BIOS Setup Utility program" on page 13.)
2. From the **Security** menu, select **Set Power-On Password** and press the **Enter** key.
3. The password dialog box will be displayed. Type the current password then press the **Enter** key.
4. Type the new password, then press the **Enter** key. Re-type the password to confirm the new password, if you type the new password correctly, the new password will be installed. A setup notice will display that changes have been saved.

To delete a previously set Power-On Password, do the following :

1. From the **Security** menu, select **Set Power-On Password** and press the **Enter** key.
2. The password dialog box will be displayed. Type the current password and press the **Enter** key.
3. To delete the **Power-On Password**, **Enter** blank fields for each new password line item. A setup notice will display that changes have been saved.
4. Return to the Lenovo BIOS Setup Utility program menu and select the **Exit** option.
5. Select **Save changes and Exit** from the menu.

Enabling or disabling a device

The Devices options is used to enable or disable user access to the following devices:	
USB Functions	Select whether to enable or disable USB (Universal Serial Bus) functions. If the functions are disabled, no USB devices can be used.
ATA Drive Setup	Select IDE or ACHI mode. Device driver support is required for ACHI mode. Depending on how the hard disk image was installed, changing this setting may prevent the system from booting.
Onboard Audio Controller	Select whether to enable or disable the Onboard Audio Controller , when feature is set to Disabled all devices connected to the audio connectors (e.g. a headphone or a microphone) are disabled and can't be used.
Onboard Ethernet Controller or Boot Agent	Select whether to enable or disable Onboard Ethernet Controller , or select whether to enable or disable load onboard PXE (Preboot Execution Environment) , or SMC (Secure Managed Client) . This feature will allow the computer to boot from a server image.

To enable or disable a device, do the following:

1. Start the Setup Utility program (see "Starting the Setup Utility program" on page 13).
2. From the Setup Utility program menu, select **Devices**.
3. Select:

USB Setup press the **Enter** key, and then select **USB Functions**.

ATA Device Setup press the **Enter** key. Select **Configure SATA as**, press the **Enter** key and then select SATA mode.

Audio Setup press the **Enter** key, and then select **Onboard Audio Controller**.

Network Setup press the **Enter** key, then select **Onboard Ethernet Support** or **Boot Agent**.

4. Select **Disabled** or **Enabled** and press the **Enter** key.
5. Return to the Lenovo BIOS Setup Utility program menu and select the **Exit** option.
6. Select **Save changes and Exit** from the menu.

Note: If you do not want to save the settings, select **Discard changes and Exit** from the menu.

Selecting a startup device

If your computer does not boot from a device such as the CD/DVD-ROM drive disk or hard disk as expected, follow one of the procedures below.

Selecting a temporary startup device

Use this procedure to startup from any boot device.

Note: Not all CDs, DVDs or hard disk drives are bootable.

1. Turn off your computer.
2. Press and hold the **F12** key then turn on the computer. When the **Startup Device Menu** appears, release the **F12** key.

Note: If the **Startup Device Menu** does not display using these steps, repeatedly press and release the **F12** key rather than keeping it pressed when turning on the computer.

3. Use **↑** and **↓** arrows to select the desired startup device from the **Startup Device Menu** and press the **Enter** key to begin.

Note: Selecting a startup device from the **Startup Device Menu** does not permanently change the startup sequence.

Selecting or changing the startup device sequence

To view or permanently change the configured startup device sequence, do the following:

1. Start the Lenovo BIOS Setup Utility program (see “Starting the Lenovo BIOS Setup Utility program” on page 13).
2. From the Lenovo BIOS Setup Utility program main menu, select the **Startup** option.
3. Press the **Enter** key, and select the devices for the **Primary Boot Sequence**. Read the information displayed on the right side of the screen.
4. Use **-** and **←** arrows to select a device. Use the **<+>** or **<->** keys to move a device up or down. Use the **<x>** key to exclude the device from or include the device in the boot sequence.
5. Return to the Lenovo BIOS Setup Utility program menu and select the **Exit** option.
6. Select **Save changes and Exit** from the menu.

Notes:

- a. If you do not want to save the settings, select **Discard changes and Exit** from the menu.

- b. If you have changed these settings and want to return to the default settings, select **Load Optimal Defaults** from the menu.

Exiting the Lenovo BIOS Setup Utility program

After you finish viewing or changing settings, press the **Esc** key to return to the Lenovo BIOS Setup Utility program main menu. You might have to press the **Esc** key several times. Do one of the following:

- If you want to save the new settings, select **Save changes and Exit** from the menu. When the **Save & reset** window shows, select the **Yes** button, and then press the **Enter** key to exit the Lenovo BIOS Setup Utility program.
- If you do not want to save the settings, select **Discard changes and Exit** from the menu. When the **Reset Without Saving** window shows, select the **Yes** button, and then press the **Enter** key to exit the Setup Utility program.

Chapter 6. Symptom-to-FRU Index

The Symptom-to-FRU index lists error symptoms and possible causes. The most likely cause is listed first. Always begin with Chapter 4, “General Checkout,” on page 11. This index can also be used to help you decide which FRUs to have available when servicing a computer. If you are unable to correct the problem using this index, go to “Undetermined problems” on page 20.

Notes:

- If you have both an error message and an incorrect audio response, diagnose the error message first.
- If you cannot run the diagnostic tests or you get a diagnostic error code when running a test but did receive a POST error message, diagnose the POST error message first.
- If you did not receive any error message look for a description of your error symptoms in the first part of this index.

Hard disk drive boot error

A hard disk drive boot error can have the following causes.

Error	FRU/Action
The startup drive is not included in the boot sequence in configuration.	Check the configuration and ensure the startup drive is in the boot sequence.
No operating system installed on the boot drive.	Install an operating system on the boot drive.
The boot sector on the startup drive is corrupted.	The drive must be formatted. Do the following: <ol style="list-style-type: none">1. Attempt to back-up the data on the failing hard disk drive.2. Use the operating system to format the hard disk drive.
The drive is defective.	Replace the hard disk drive.

Power Supply Problems

Follow these procedures if you suspect there is a power supply problem.

Check/Verify	FRU/Action
Check that the following are properly installed: <ul style="list-style-type: none">• Power Cord• On/Off Switch connector• System Board Power Supply connectors• Microprocessor(s) connection	Reseat connectors
Check the power cord.	Power Cord
Check the power-on switch.	Power-on Switch

Additional Service Information

This chapter provides additional information that the service representative might find helpful.

Power management

Power management reduces the power consumption of certain components of the computer such as the system power supply, processor, hard disk drives, and some monitors.

Advanced configuration and power interface (ACPI) BIOS

As this computer has an ACPI BIOS system, the operating system is allowed to control the power management features of the computer and the settings for Advanced Power Management (APM) BIOS mode is ignored. Not all operating systems support ACPI BIOS mode.

Automatic Power-On features

The Automatic Power-On features within the Power Management menu allow you to enable and disable features that turn on the computer automatically.

- **Wake Up on Alarm:** You can specify a date and time at which the computer will be turned on automatically. This can be either a single event, a daily event or a weekly event.
- **Wake Up on LAN:** This feature allows LAN adapter card to wake the System.

POST error codes

Each time you turn the computer on, it performs a series of tests to check that the system is operating correctly and that certain options are set. This series of tests is called the *Power-On Self-Test*, or *POST*. POST does the following:

- Checks some basic system-board operations
- Checks that the memory is working correctly
- Starts video operations
- Verifies that the boot drive is working

POST Error Message	Description/Action
Keyboard error	Cannot initialize the keyboard. Make sure the keyboard is properly connected to the computer and that no keys are held pressed during POST. To purposely configure the computer without a keyboard, select Keyboardless operation in Startup option to Enabled . The BIOS then ignores the missing keyboard during POST.
Reboot and Select proper Boot device or Insert Boot Media in selected Boot device	The BIOS was unable to find a suitable boot device. Make sure the boot drive is properly connected to the computer. Make sure you have bootable media in the boot device.

Undetermined problems

1. Power-off the computer.
2. Remove or disconnect the following components (if connected or installed) one at a time.
 - a. External devices (modem, printer, or mouse)
 - b. Extended video memory
 - c. External Cache
 - d. External Cache RAM
 - e. Hard disk drive
 - f. Disk drive

3. Power-on the computer to re-test the system.
4. Repeat steps 1 through 3 until you find the failing device or component.

If all devices and components have been removed and the problem continues, replace the system board.

Chapter 7. Locations

This section provides illustrations to help locate the various connectors, controls and components of the computer.

Identifying internal components

The following illustration shows the components inside your computer.



No.	Description	Self-service CRU	Optional-service CRU
1	Memory module	Yes	No
2	Wi-Fi card	No	Yes
3	XBOX dongle	No	No
4	CPU	No	No
5	Solid state drive and bracket	Yes	Yes

6	Hard disk drive	Yes	No
7	Hard disk drive bracket	Yes	No
8	Graphic card	No	Yes
9	Front I/O module	No	No
10	Motherboard	No	No
11	Power supply unit	No	No
12	Fan bracket	No	No
13	Heat-sink and fan assembly	No	No
14	Front bezel	No	No
15	Top cover	No	No
16	Chassis	No	No
17	Computer cover	No	No
18	Computer cover (Lenovo logo)	No	No
19	Bottom cover	No	No

Identifying parts on the system board

The system board (also known as the “mainboard” or “motherboard”) is the main circuit board in your computer. It provides basic computer functions and supports a variety of devices that are factory-installed or that you can install later.

The following illustrations show the locations of the different parts on the system board.

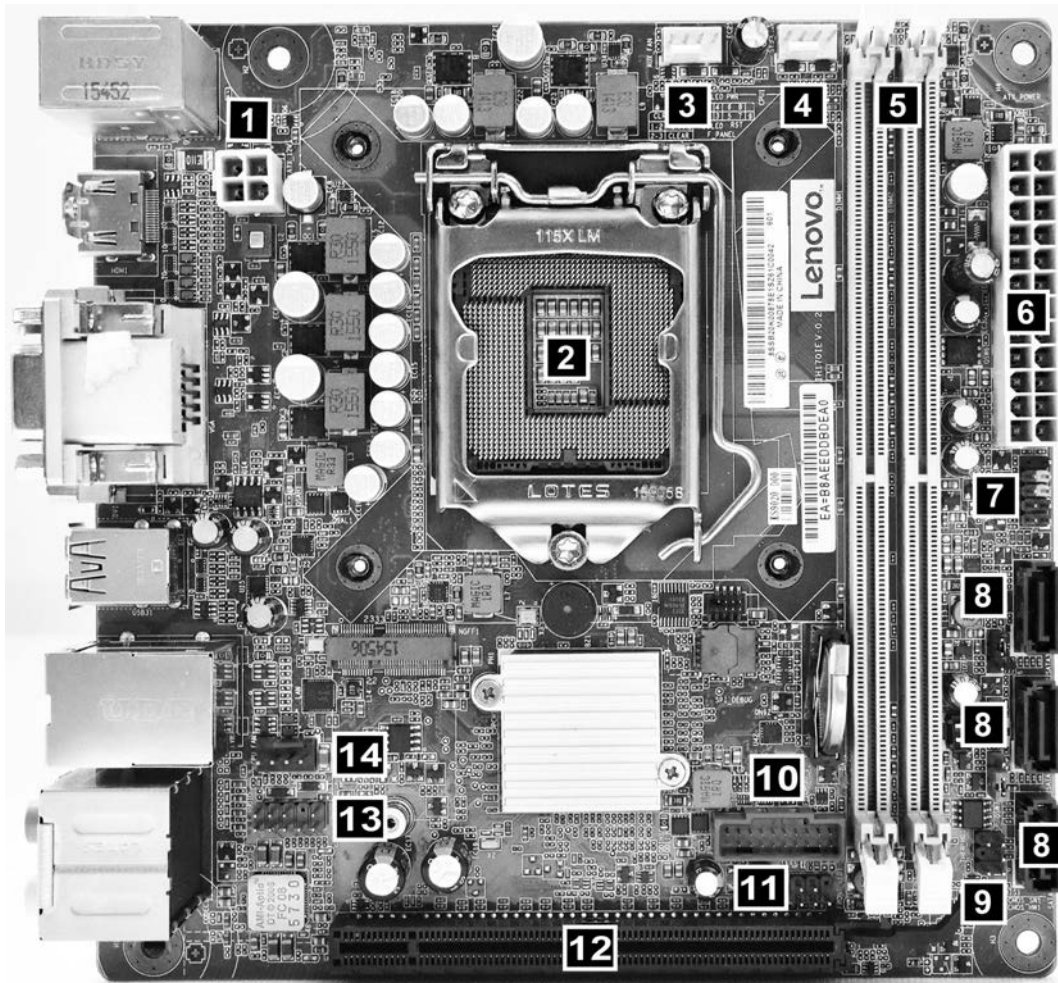

1 12V power connector	8 Front USB 3.0 slot
2 Microprocessor	9 SATA connectors (3)
3 Aux fan header	10 Thermal sensor header
4 System fan header 2	11 Front I/O module header
5 Memory slots (2)	12 Front LED header
6 Power connector	13 Front audio header
7 Front panel header	14 CPU fan header

Chapter 8. Replacing hardware

Attention: Do not remove the computer cover or attempt any repair before reading the “Important safety information” in the *Safety and Warranty Guide* that was included with your computer. To obtain copies of the Safety and Warranty Guide, go to the Support Web site at: <http://consumersupport.lenovo.com>

General information

Pre-disassembly instructions

Before proceeding with the disassembly procedure, make sure that you do the following:

1. Turn off the power to the system and all peripherals.
2. Unplug all power and signal cables from the computer.
3. Place the system on a flat, stable surface.

General information

Pre-disassembly instructions

Before proceeding with the disassembly procedure, make sure that you do the following:

1. Turn off the power to the system and all peripherals.
2. Unplug all power and signal cables from the computer.
3. Place the system on a flat, stable surface.

Replacing the keyboard and mouse

Note: Your keyboard will be connected to a USB connector at either front or at the rear of the computer.

To replace the keyboard:

- Step 1. Remove any media (disks, CDs, or memory cards) from the drives, shut down the computer, and turn off all attached devices.
- Step 2. Unplug all power cords from electrical outlets.
- Step 3. Locate the connector for the keyboard. Refer to “Front view of the chassis” and “Rear view of the chassis”.

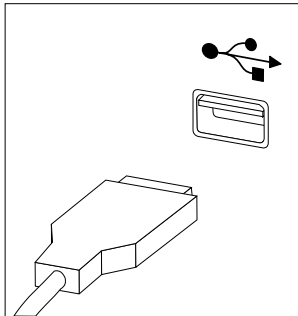

- Step 4. Disconnect the defective keyboard cable from the computer and connect the new keyboard cable to the same connector.
- Step 5. The mouse can be replaced using the same method.

Removing the computer cover

Attention:

- Turn off the computer and wait 3 to 5 minutes to let it cool down before removing the cover.
- For this procedure, it helps to lay the computer on a flat, stable surface.

To remove the computer cover:

- Step 1. Remove any media (disks, CDs, or memory cards) from the drives, shut down the computer, and turn off all attached devices.
- Step 2. Unplug all power cords from electrical outlets.
- Step 3. Disconnect all cables attached to the computer. This includes power cords, input/output (I/O) cables, and any other cables that are connected to the computer. Refer to “Locating connectors on the rear of the computer”.

Step 4. Remove the two screws that secures the cover, slide the computer cover outward as shown.

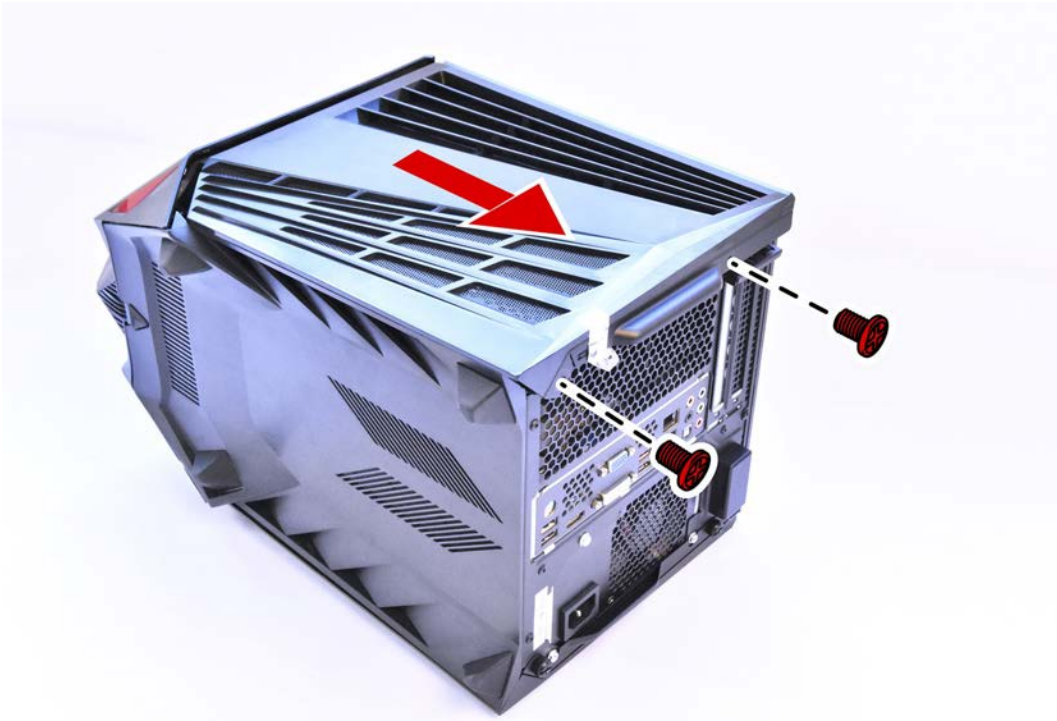

Step 5. Reinstall the computer cover:

- a. Align the cover with the guide track on the computer case, then slide the cover in.
- b. Secure the computer cover with the two screws.

Removing the computer cover(Lenovo logo)

Attention: Turn off the computer and wait 3 to 5 minutes to let it cool down before removing the cover.

Note: It may be helpful to place the computer face-down on a soft flat surface for this procedure. Lenovo recommends that you use a blanket, towel, or other soft cloth to protect the computer screen from scratches or other damage.

To remove the computer cover:

- Step 1. Remove any media (disks, CDs, DVDs, or memory cards) from the drives, shut down the operating system, and turn off the computer and all attached devices.
- Step 2. Unplug all power cords from electrical outlets.
- Step 3. Disconnect all cables attached to the computer. This includes power cords, input/output (I/O) cables, and any other cables that are connected to the computer. Refer to “Left and right view” and “Rear view” for help with locating the various connectors.
- Step 4. Remove the 2 screws that secure the computer cover at the rear of the chassis, then slide computer cover outward as shown.

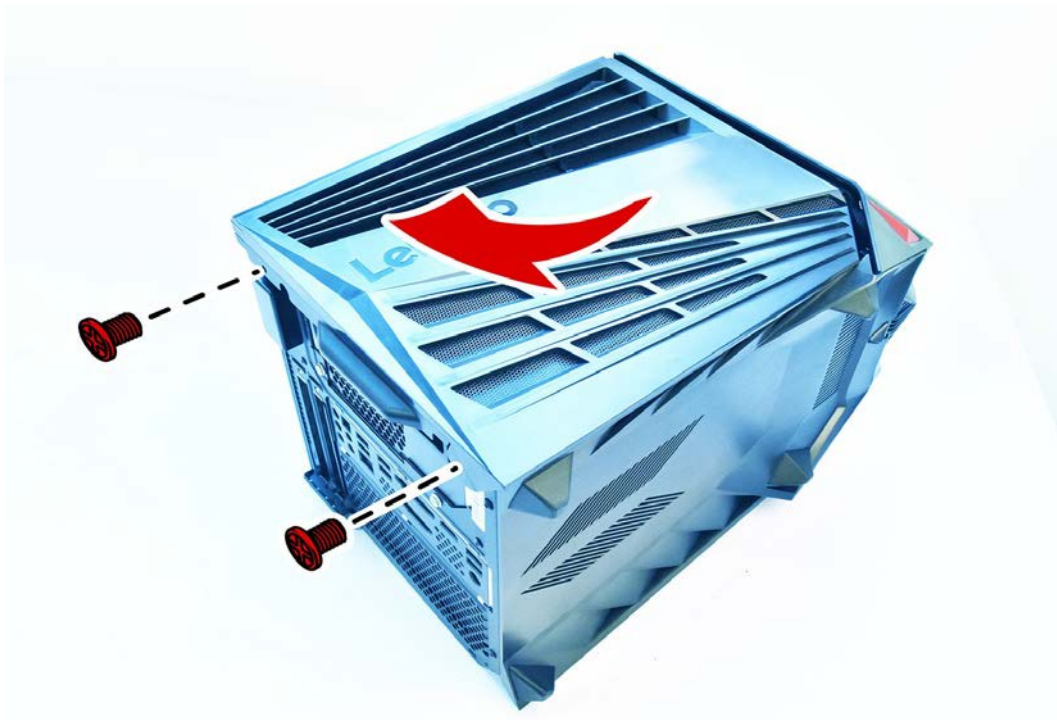

- Step 5. To reinstall the computer cover:
- Line up the computer cover with the chassis then slide it back.
 - Secure the computer cover to the chassis with the screws.

Removing the top cover

Attention:

- Turn off the computer and wait 3 to 5 minutes to let it cool down before removing the cover.
- For this procedure, it helps to lay the computer on a flat, stable surface.

To remove the top cover:

- Step 1. Remove any media (disks, CDs, or memory cards) from the drives, shut down the computer, and turn off all attached devices.
- Step 2. Unplug all power cords from electrical outlets.
- Step 3. Disconnect all cables attached to the computer. This includes power cords, input/output (I/O) cables, and any other cables that are connected to the computer. Refer to “Locating connectors on the rear of the computer”.
- Step 4. Remove the computer cover. Refer to “Removing the computer cover”.
- Step 5. Remove the computer cover(Lenovo logo). Refer to “Removing the computer cover(Lenovo logo)”.
- Step 6. The top cover is pinned to the chassis, push the pins as shown to release the top cover. Lift up the top cover to remove it.

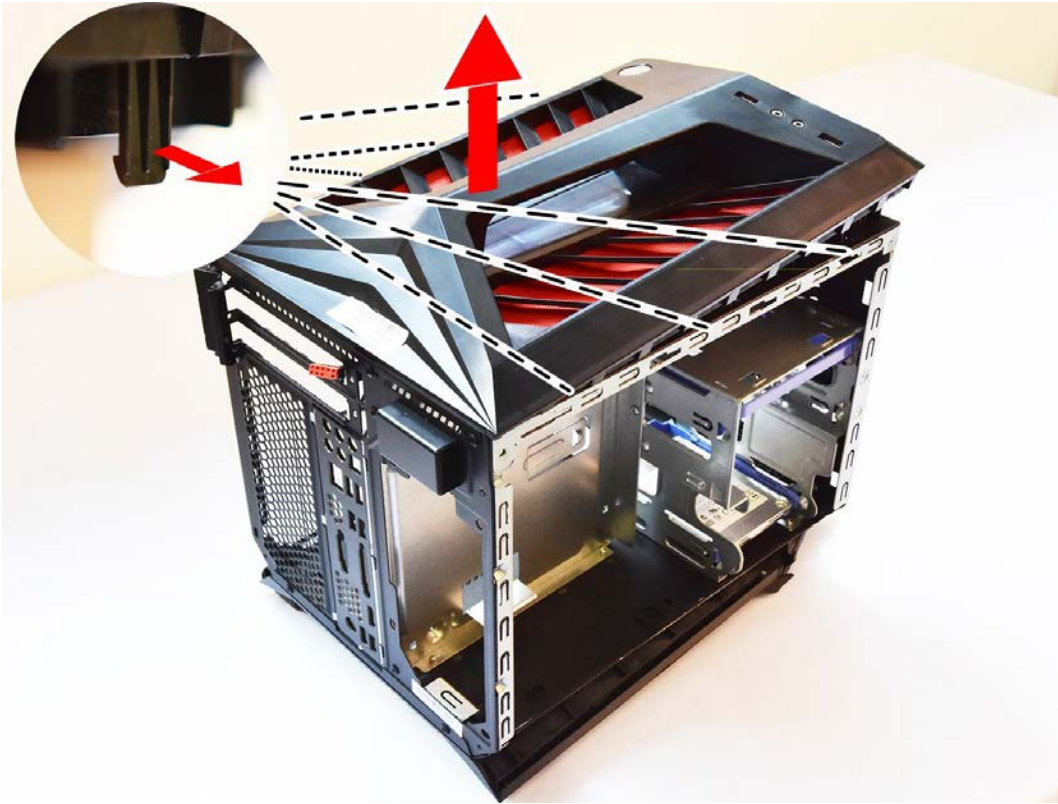

Step 7. Reinstall the top cover:

- a. Align the pins on the top cover with the mounting holes on the chassis, then place the top cover back.
- b. Press down the locking fin to secure the top cover.

Step 8. Reattach the computer covers.

Removing the bottom cover

Attention:

- Turn off the computer and wait 3 to 5 minutes to let it cool down before removing the cover.
- For this procedure, it helps to lay the computer upside-down on a flat, stable surface.

To remove the bottom cover:

- Step 1. Remove any media (disks, CDs, or memory cards) from the drives, shut down the computer, and turn off all attached devices.
- Step 2. Unplug all power cords from electrical outlets.
- Step 3. Disconnect all cables attached to the computer. This includes power cords, input/output (I/O) cables, and any other cables that are connected to the computer. Refer to “Locating connectors on the rear of the computer”.
- Step 4. Remove the computer cover. Refer to “Removing the computer cover”.
- Step 5. Remove the computer cover(Lenovo logo). Refer to “Removing the computer cover(Lenovo logo)”.
- Step 6. Slide the bottom cover to remove it..





Step 7. Reinstall the bottom cover:

- a. Align the pins on the bottom cover with the mounting holes on the chassis, then slide the bottom cover back.

Step 8. Reattach the computer covers.

Removing the front bezel

Note: For this procedure, it helps to lay the computer flat.

To remove the front bezel:

Step 1. Remove the computer cover. Refer to “Removing the computer cover”.

Step 2. Remove the front bezel by releasing the four plastic tabs from inside the chassis (two on left, two on right side) **1** and slide the bezel out slowly as shown. **2**

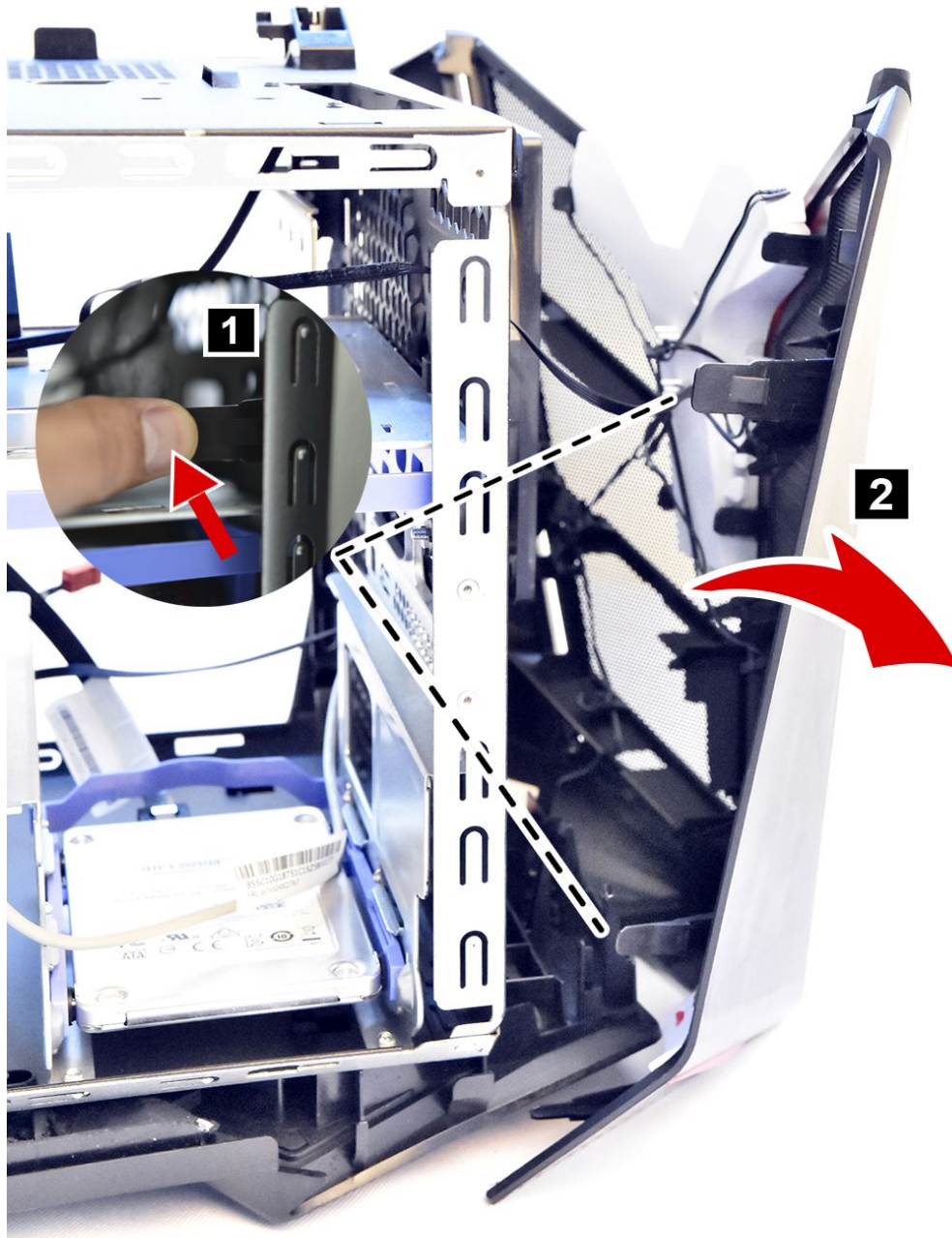

Step 3. Disconnect the front LED from the connector on the motherboard.

Step 4. To reattach the bezel, align the plastic tabs on the bottom of the bezel with the corresponding holes in the chassis, and then snap it into position.

Replacing the xbox dongle

Note: For this procedure, it helps to lay the computer on a flat, stable surface.

To replace the xbox dongle:

- Step 1. Remove the computer cover. Refer to “Removing the computer cover”.
- Step 2. Remove the computer cover(Lenovo logo). Refer to “Removing the computer cover(Lenovo logo)”.
- Step 3. Remove the top cover. Refer to “Removing the top cover”.
- Step 4. Remove the front bezel. “Removing the front bezel.”
- Step 5. Push the pins to release the xbox dongle as shown.



- Step 6. Install the new xbox dongle into the same port.
- Step 7. Place the new xbox dongle into position and secure the dongle with the locking pins..

Step 8. Reattach the front bezel, top cover, computer cover, computer cover(Lenovo logo).

Replacing a memory module

Note: For this procedure, it helps to lay the computer flat.

To replace a memory module:

Step 1. Remove the computer cover. Refer to “Removing the computer cover”.

Step 2. Locate the memory module connectors. Refer to “Locating components”.

Step 3. Remove the memory module to be replaced by opening the retaining clips as shown. **a b**

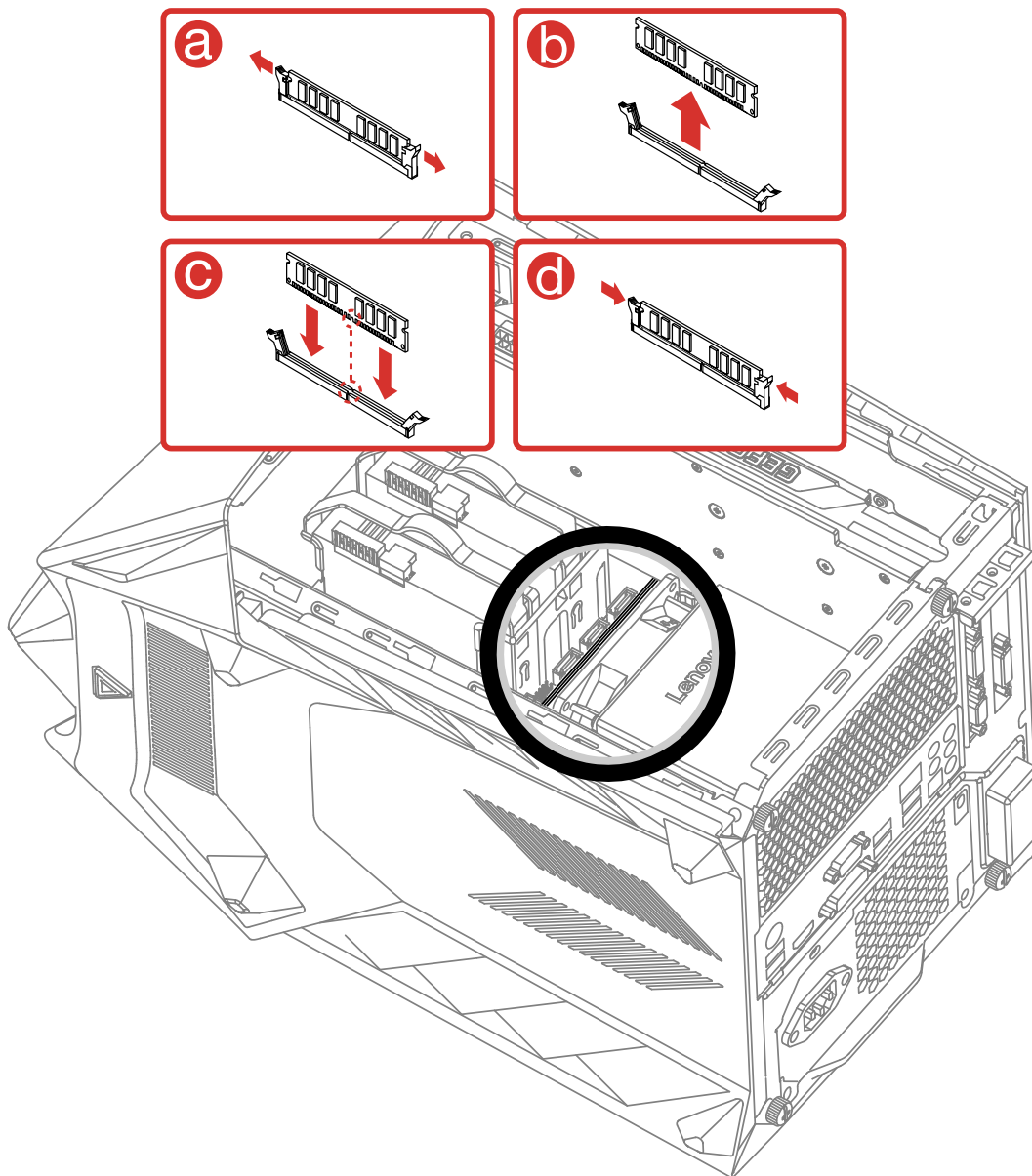

Step 4. Position the new memory module over the memory connector. Make sure that the notch **c** on the memory module aligns correctly with the connector key **d** on the system board. Push the memory module straight down into the connector until the retaining clips close.

Step 5. Reattach the computer cover.

Replacing a hard disk drive

Note: For this procedure, it helps to lay the computer flat.

To replace a hard disk drive:

Step 1. Remove the computer cover. Refer to “Removing the computer cover”.

Step 2. Disconnect the data and power cables from the hard disk drive. **a**

Step 3. Pull the plastic handle and slide the hard disk drive out of the drive bay. **b**

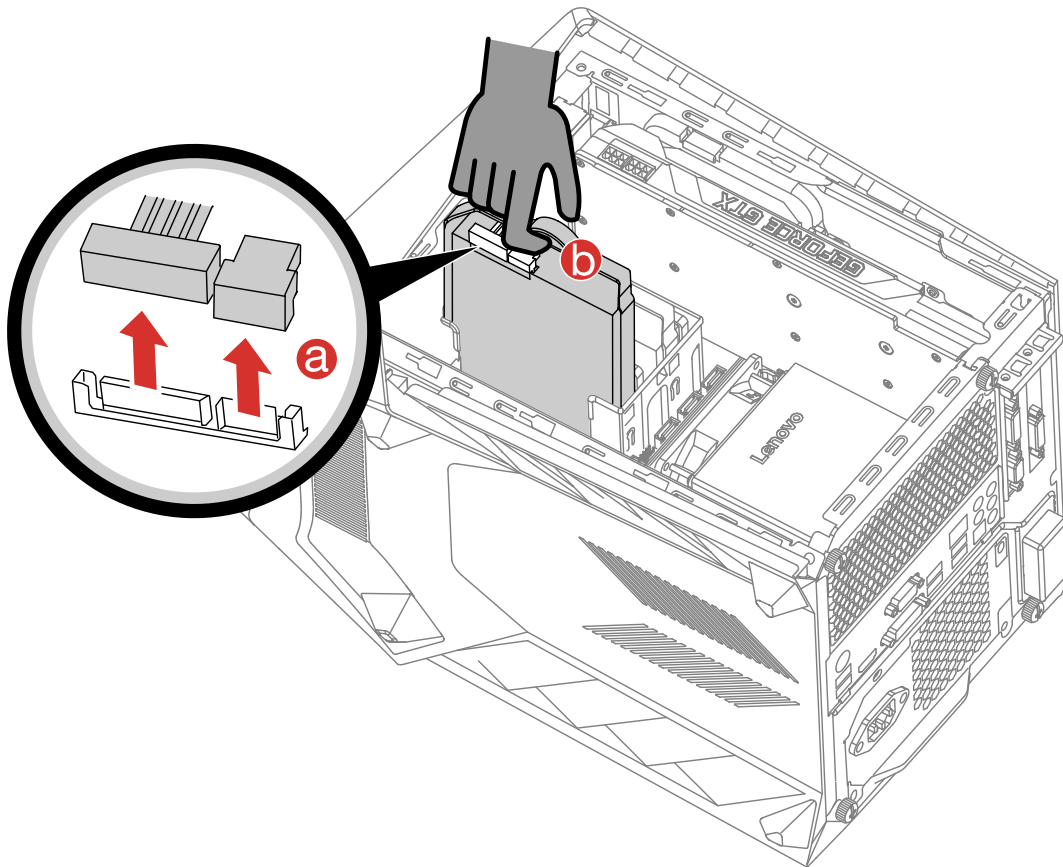

Step 4. Release the hard disk drive from the bracket as shown. **c d**

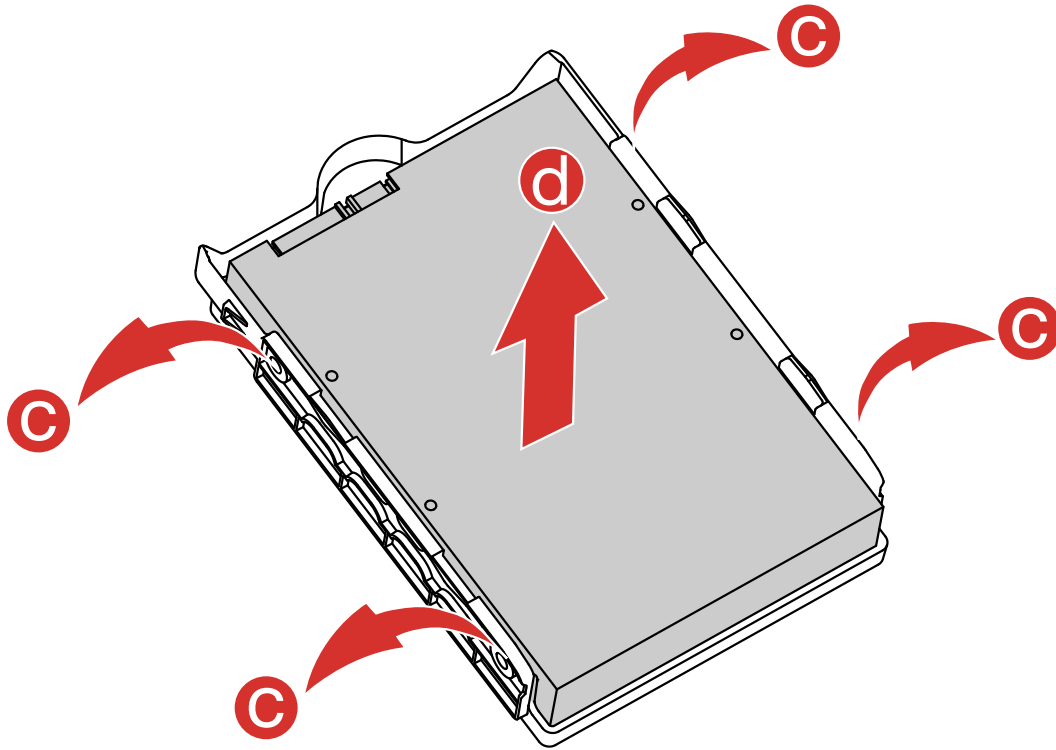

Step 5. Line up the new hard disk drive with the plastic bracket and snap it into position.

Step 6. Slide the new hard disk drive into the drive bay and slide the drive bay into place.

Step 7. Connect the power and signal cables to the new hard disk drive.

Step 8. Reattach the computer cover.

Replacing a solid state drive

Note: For this procedure, it helps to lay the computer flat.

To replace a solid state drive:

Step 1. Remove the computer cover. Refer to “Removing the computer cover”.

Step 2. The solid state drive bracket is locked to the drive bay the locking pins, push in the solid state drive bracket to release.



Step 3. Disconnect the data and power cables from the solid state drive. **a**

Step 4. Pull the plastic handle and slide the solid state drive out of the drive bay. **b**

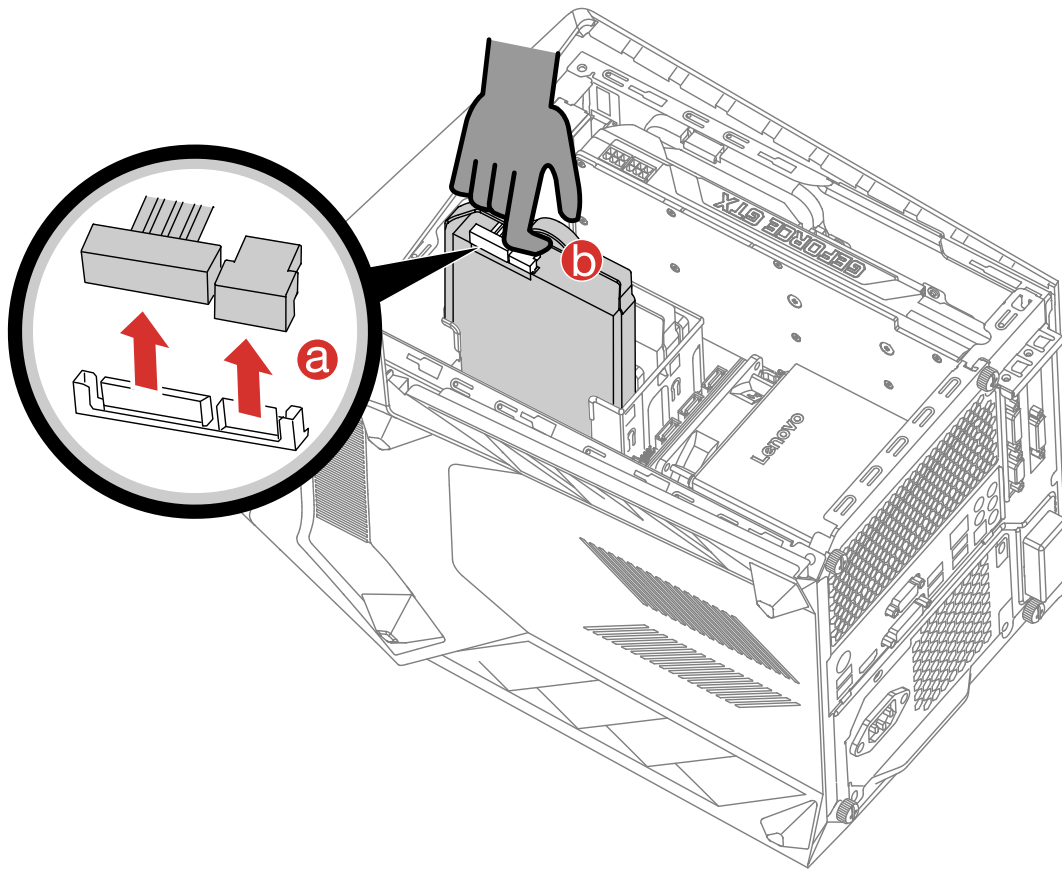

Step 5. Release the solid state drive from the bracket as shown. **c d**

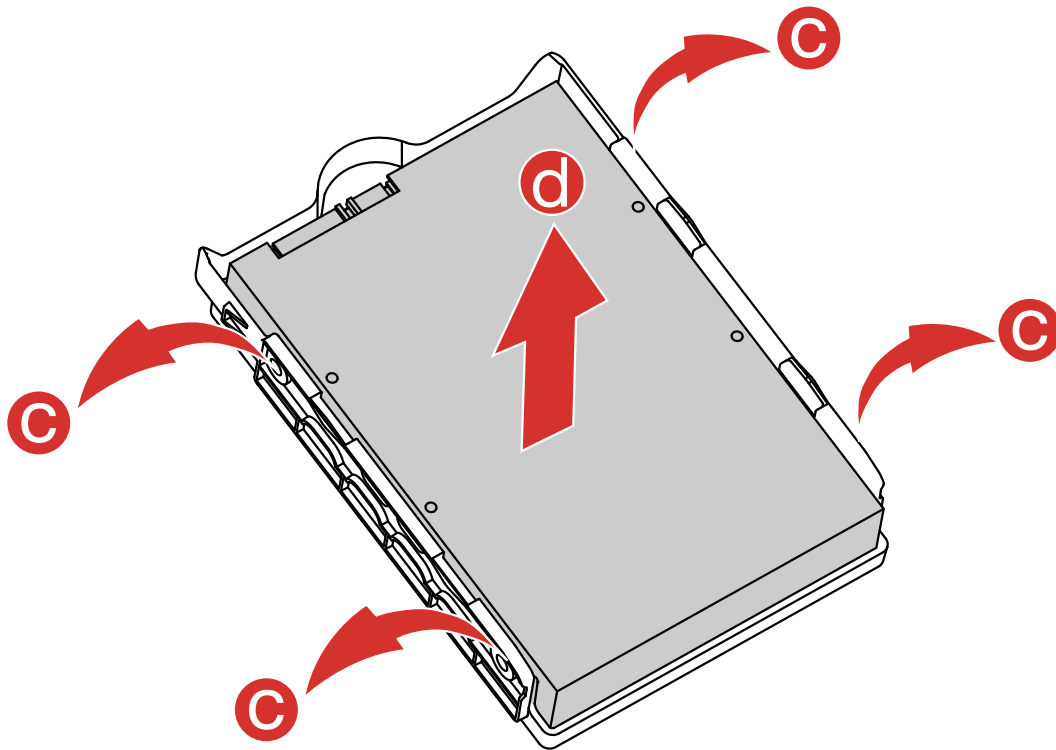

Step 6. Line up the new solid state drive with the plastic bracket and snap it into position.

Step 7. Slide the new solid state drive into the drive bay and slide the drive bay into place.

Step 8. Connect the power and signal cables to the new solid state drive.

Step 9. Reattach the computer cover.

Replacing the heat-sink assembly

To replace the heat-sink assembly:

Step 1. Remove any media (disks, CDs, DVDs, or memory cards) from the drives, shut down the operating system, and turn off the computer and all attached devices.

Step 2. Unplug all power cords from electrical outlets.

Step 3. Disconnect all cables attached to the computer. This includes power cords, input/output (I/O) cables, and any other cables that are connected to the computer. Refer to “Left and right view” and “Rear view” for help with locating the various connectors.

Step 4. Remove the computer cover. Refer to “Removing the computer cover”.

Step 5. Disconnect the fan power cable from the connector on the motherboard.

Step 6. Remove the 4 screws that secure the heat-sink to the heat-sink and lift up the heat-sink to remove it.



Step 7. To install the new heat-sink assembly:

- a. Line up the new heat-sink assembly with the mounting holes on the motherboard, secure the new heat-sink assembly with 4 screws.
- b. Connect the fan power cable to the connector on the board.

Step 8. Reattach the computer cover.

Replacing the Wi-Fi card

Note: For this procedure, it helps to lay the computer flat.

To replace the Wi-Fi card:

- Step 1. Remove any media (disks, CDs, DVDs, or memory cards) from the drives, shut down the operating system, and turn off the computer and all attached devices.
- Step 2. Unplug all power cords from electrical outlets.
- Step 3. Disconnect all cables attached to the computer. This includes power cords, input/output (I/O) cables, and any other cables that are connected to the computer. Refer to “Left and right view” and “Rear view” for help with locating the various connectors.
- Step 4. Remove the computer cover. Refer to “Removing the computer cover”.
- Step 5. Disconnect the 2 antenna cables from the Wi-Fi card.
- Step 6. Remove the screw that secures the Wi-Fi card to the motherboard.
- Step 7. Pull the Wi-Fi card upward to remove it from the card port.

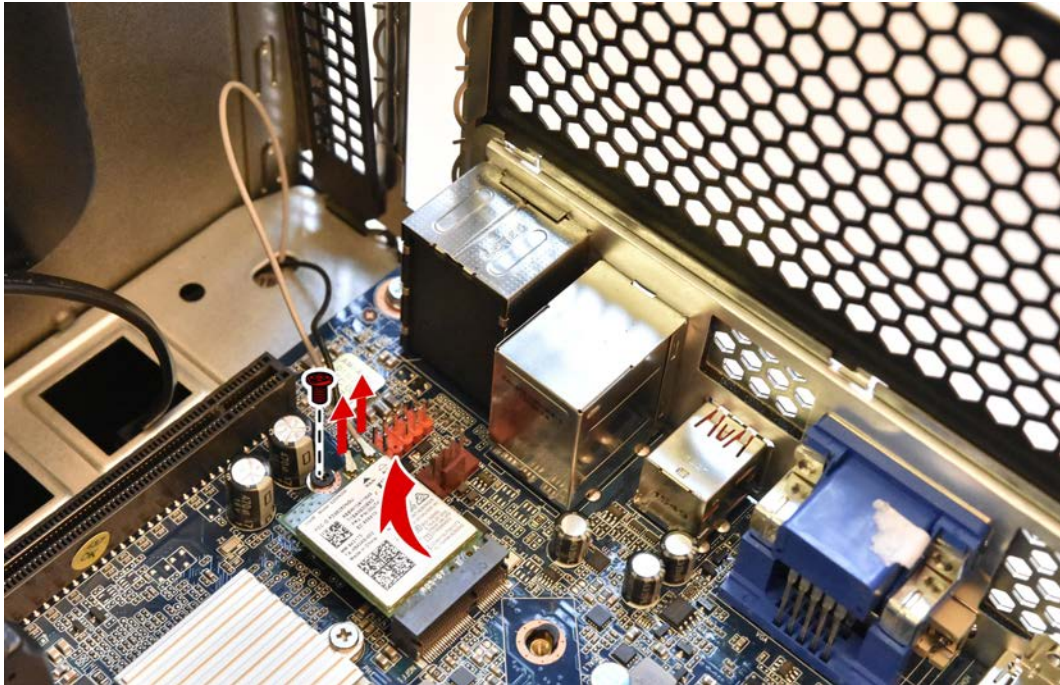



- Step 8. Install the new Wi-Fi card:
- Line up the new Wi-Fi card, then insert it into the same card port.
 - Secure the Wi-Fi card to the motherboard with the screw.
 - Connect the 2 antenna cables to the new Wi-Fi card.
- Step 9. Reattach the computer cover.

Replacing a graphics card

Note: For this procedure, it helps to lay the computer on a flat, stable surface.

To replace a graphics card:

- Step 1. Remove the computer cover. Refer to “Removing the computer cover”.

Step 2. Remove the 2 screws that secure the latches, open the latches as shown.

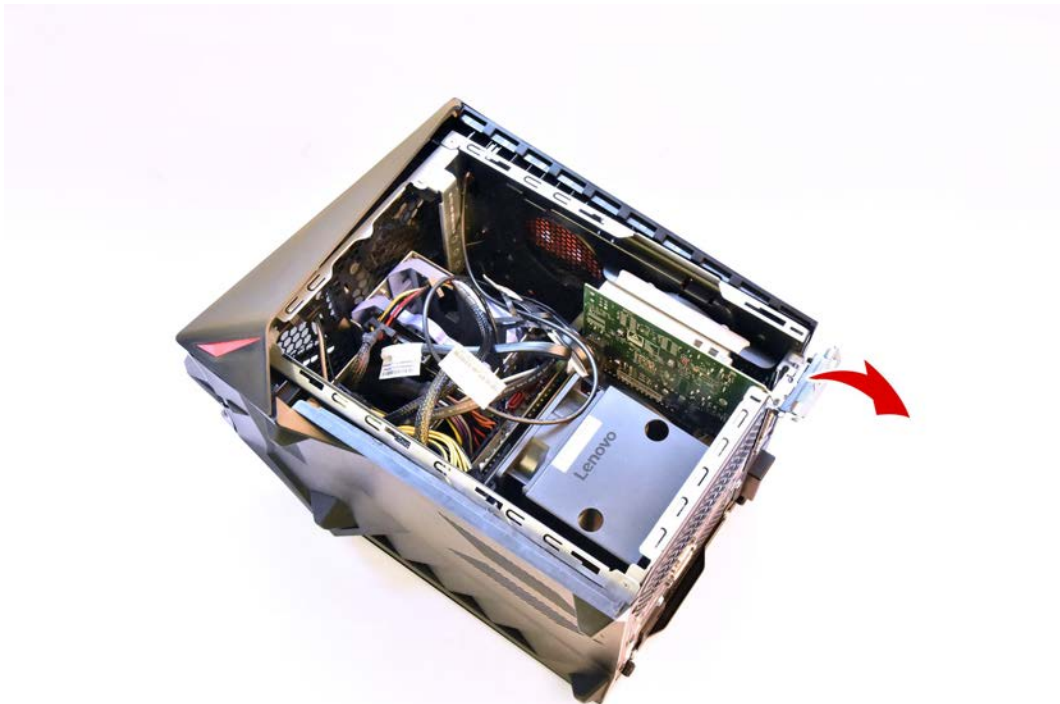

- Step 3. Disconnect the power cables from the graphics card.
- Step 4. Push the graphic card to unlock position as shown.
- Step 5. Push the locking pin outward to unlock the graphic card as shown.

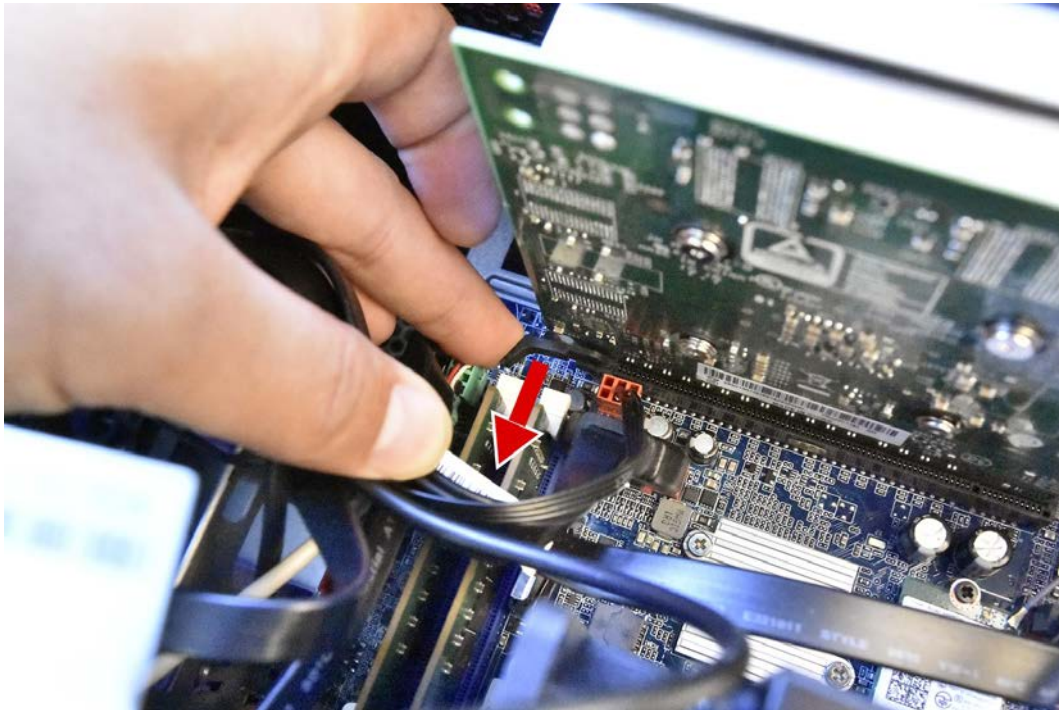

- Step 6. Lift the card straight up to remove it.

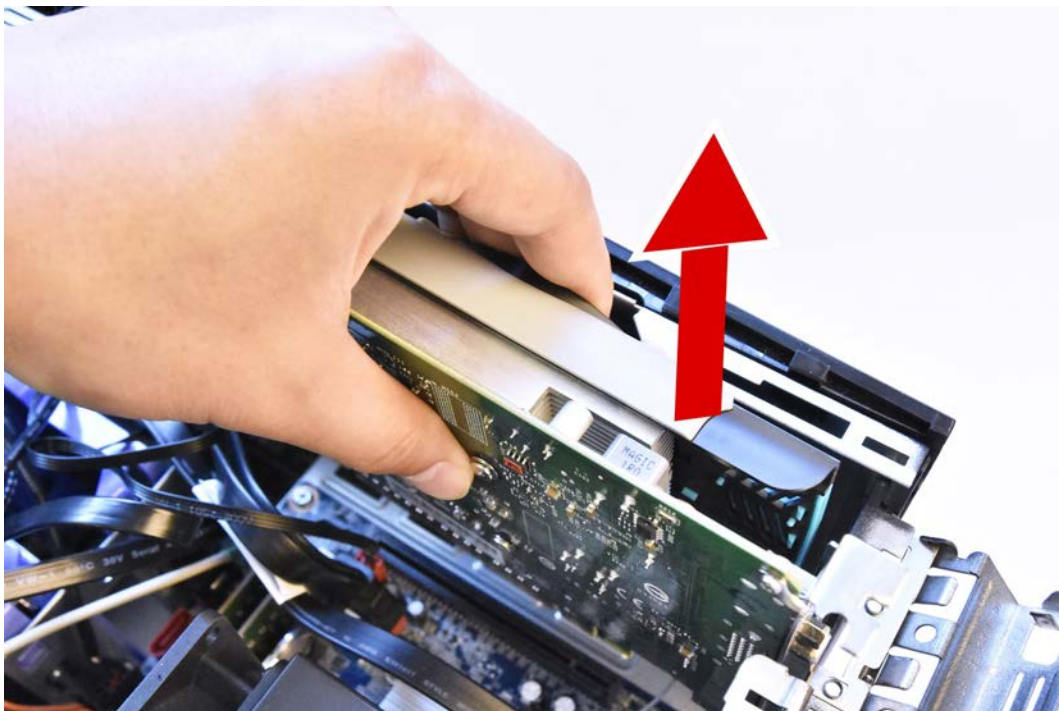



- Step 7. To install the new graphics card:
- a. Attach the new graphics card to the same adapter connector.
 - b. Connect the power cables to the new graphics card.
 - c. Close the latches and secure the latches with the 2 screws.

Step 8. Reattach the computer cover.

Replacing the CPU

Note: For this procedure, it helps to lay the computer flat.

To replace the CPU:

- Step 1. Remove any media (disks, CDs, DVDs, or memory cards) from the drives, shut down the operating system, and turn off the computer and all attached devices.
- Step 2. Unplug all power cords from electrical outlets.
- Step 3. Disconnect all cables attached to the computer. This includes power cords, input/output (I/O) cables, and any other cables that are connected to the computer. Refer to “Left and right view” and “Rear view” for help with locating the various connectors.
- Step 4. Remove the computer cover. Refer to “Removing the computer cover”.
- Step 5. Remove the microprocessor fan. Refer to “Replacing the microprocessor fan”.
- Step 6. Remove the CPU fan assembly. Refer to “Replacing the CPU fan assembly”.

Step 7. To remove the microprocessor from the system board, press then slide the small handle out to spring it up and open the retainer.

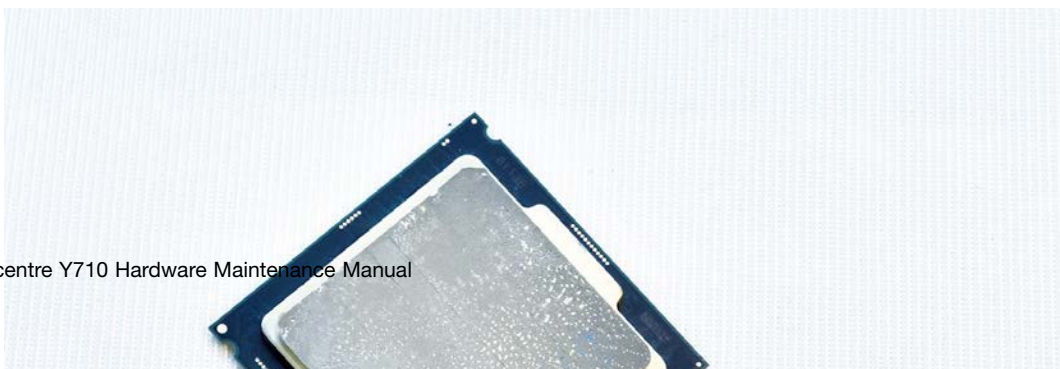
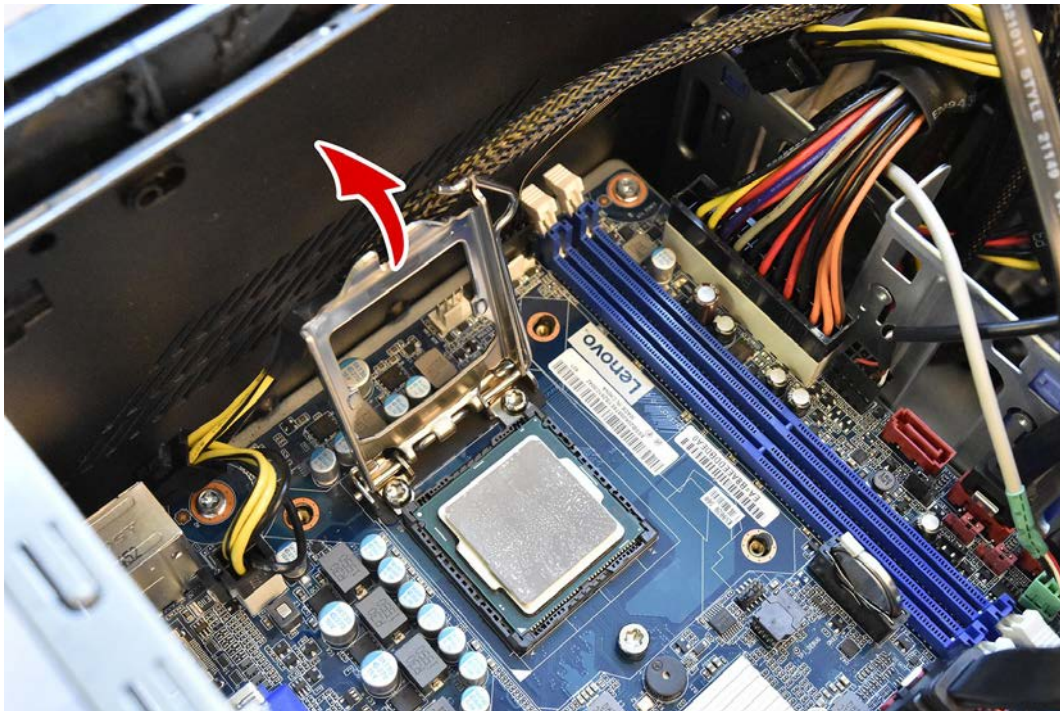
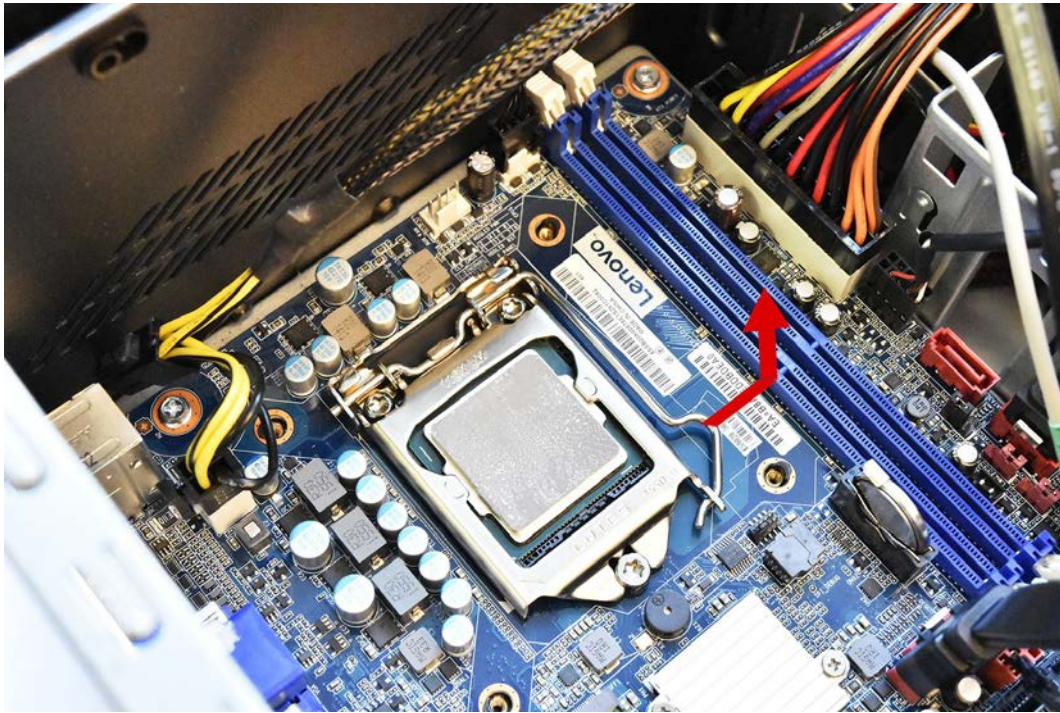

Step 8. Holding the sides of the microprocessor with your fingers, remove the protective cover **1** that protects the gold contacts on the new microprocessor. **2**

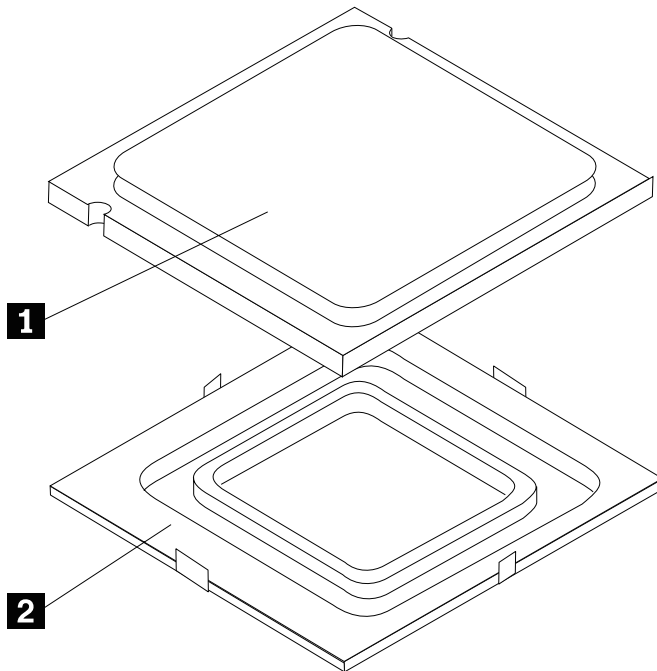

Step 9. Holding the sides of the microprocessor with your fingers, position the microprocessor so that the notches on the microprocessor are aligned with the tabs in the microprocessor socket.

Important: To avoid damaging the microprocessor contacts, keep the microprocessor completely level while installing it into the socket.

Step 10. Lower the microprocessor straight down into its socket on the motherboard.

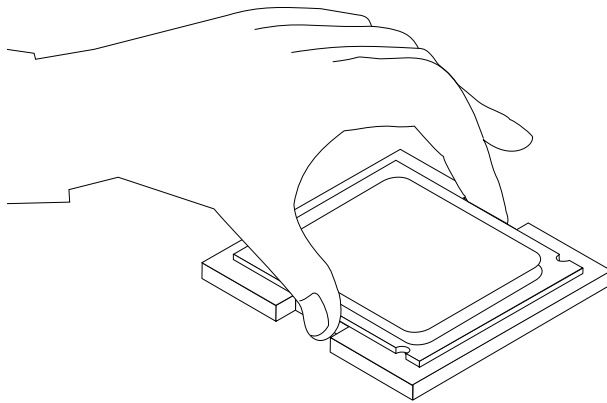

Step 11. To secure the microprocessor in the socket, close the microprocessor retainer and lock it into position with the small handle.

Step 12. Use a thermal grease syringe to place 5 drops of grease on the top of the microprocessor. Each drop of grease should be 0.03ml (3 tick marks on the grease syringe).

Step 13. Reattach the heat-sink assembly and computer cover.

Replacing the Power supply

Note: For this procedure, it helps to lay the computer flat.

To replace the Power supply:

- Step 1. Remove any media (disks, CDs, DVDs, or memory cards) from the drives, shut down the operating system, and turn off the computer and all attached devices.
- Step 2. Unplug all power cords from electrical outlets.
- Step 3. Disconnect all cables attached to the computer. This includes power cords, input/output (I/O) cables, and any other cables that are connected to the computer. Refer to “Left and right view” and “Rear view” for help with locating the various connectors.
- Step 4. Remove the computer cover(Lenovo logo). Refer to “Removing the computer cover(Lenovo logo)”.
- Step 5. Disconnect the power cables from the connectors on motherboard.
- Step 6. Remove the 4 screws that secure the Power supply to the chassis.

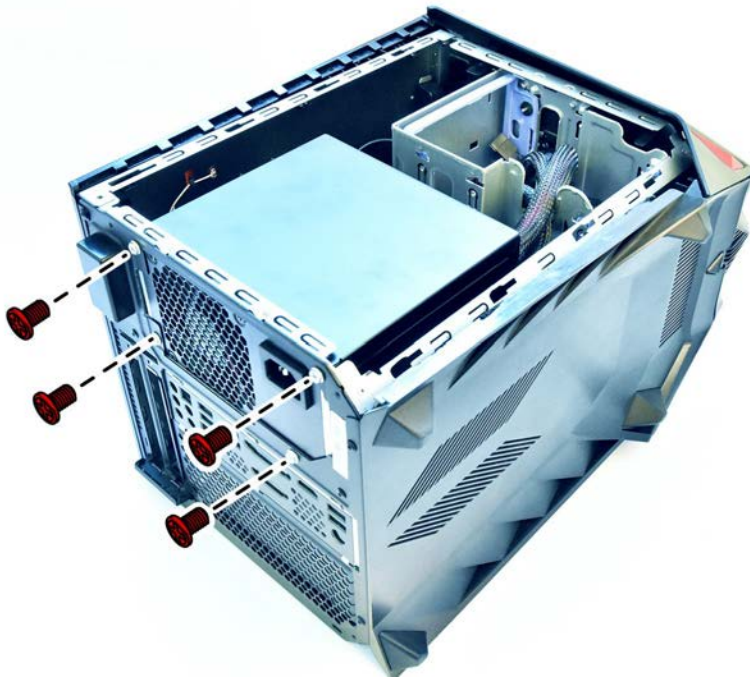

- Step 7. Push down the locking pin **1** , then slide power supply out of chassis.

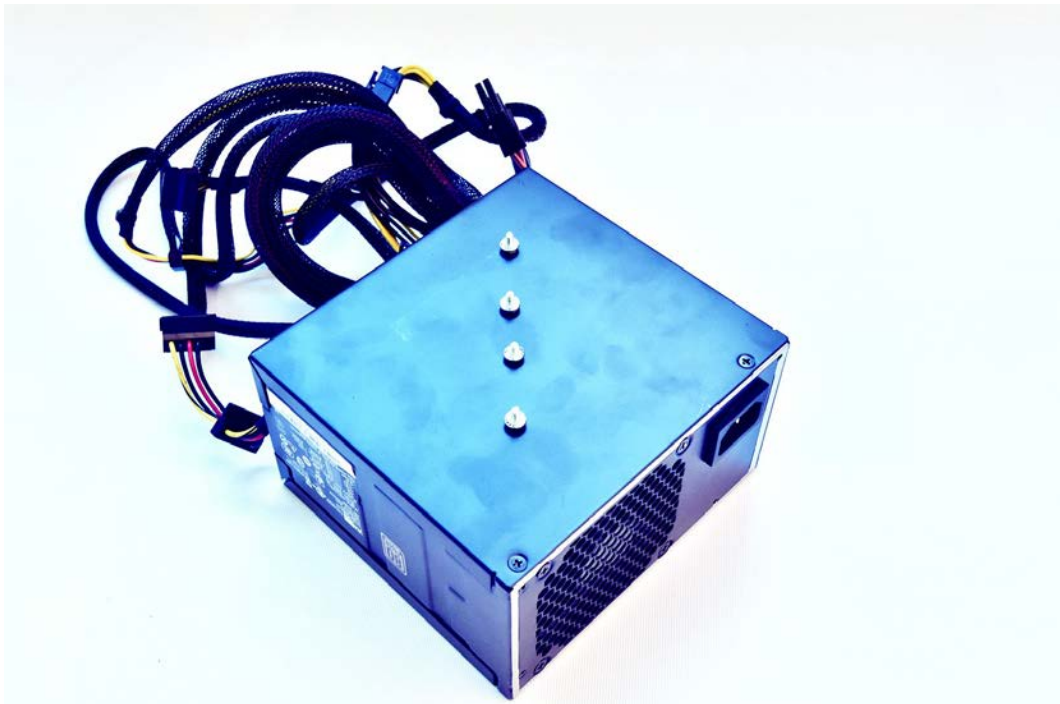
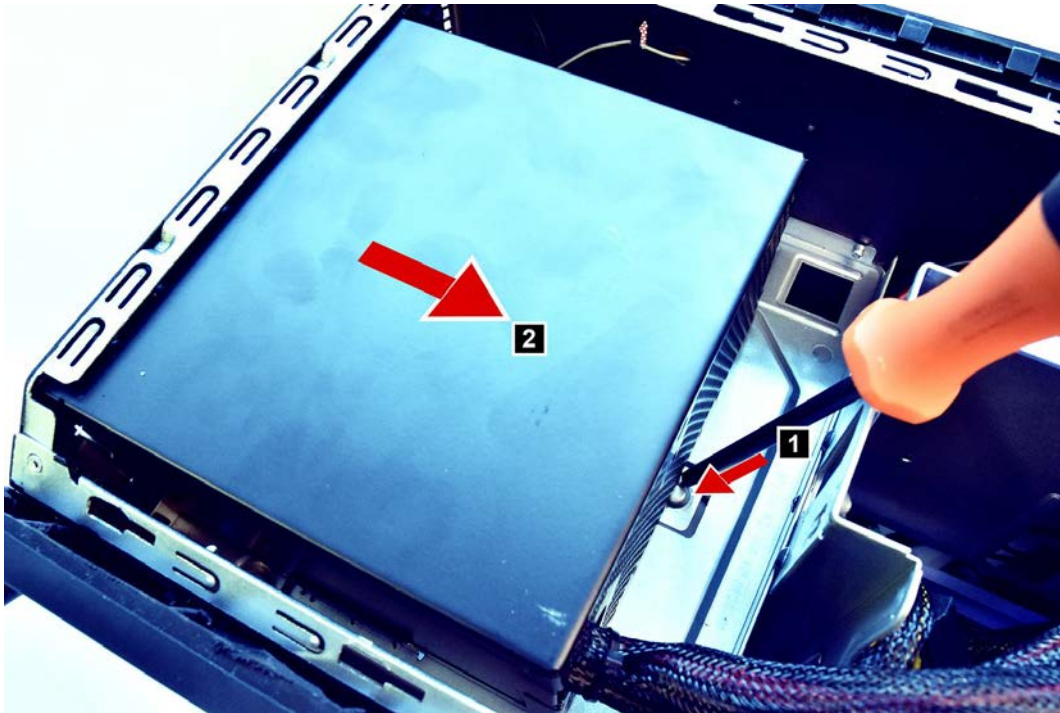

Step 8. Install the new power supply :

- a. Line up the holes on the new power supply with mounting holes on the rear of the chassis and secure it to the chassis with the 4 screws.
- b. Connect the power cables to the connectors on the motherboard.

Step 9. Reattach the computer cover.

Replacing the motherboard

Note: For this procedure, it helps to lay the computer flat.

To replace the motherboard:

- Step 1. Remove any media (disks, CDs, DVDs, or memory cards) from the drives, shut down the operating system, and turn off the computer and all attached devices.
- Step 2. Unplug all power cords from electrical outlets.
- Step 3. Disconnect all cables attached to the computer. This includes power cords, input/output (I/O) cables, and any other cables that are connected to the computer. Refer to “Left and right view” and “Rear view” for help with locating the various connectors.
- Step 4. Remove the computer cover. Refer to “Removing the computer cover”.
- Step 5. Remove the memory module. Refer to “Replacing a memory module”.
- Step 6. Remove the heat-sink assembly. Refer to “Replacing the heat-sink assembly”.
- Step 7. Remove the graphic card. Refer to “Replacing the graphic card”.
- Step 8. Remove the Wi-Fi card. Refer to “Replacing the Wi-Fi card”.
- Step 9. Remove the CPU. Refer to “Replacing the CPU”.
- Step 10. Disconnect the all cables from the connectors on motherboard.
- Step 11. Remove the 4 screws that secure the motherboard to the chassis.
- Step 12. Slide then lift the motherboard out of the chassis to remove it.

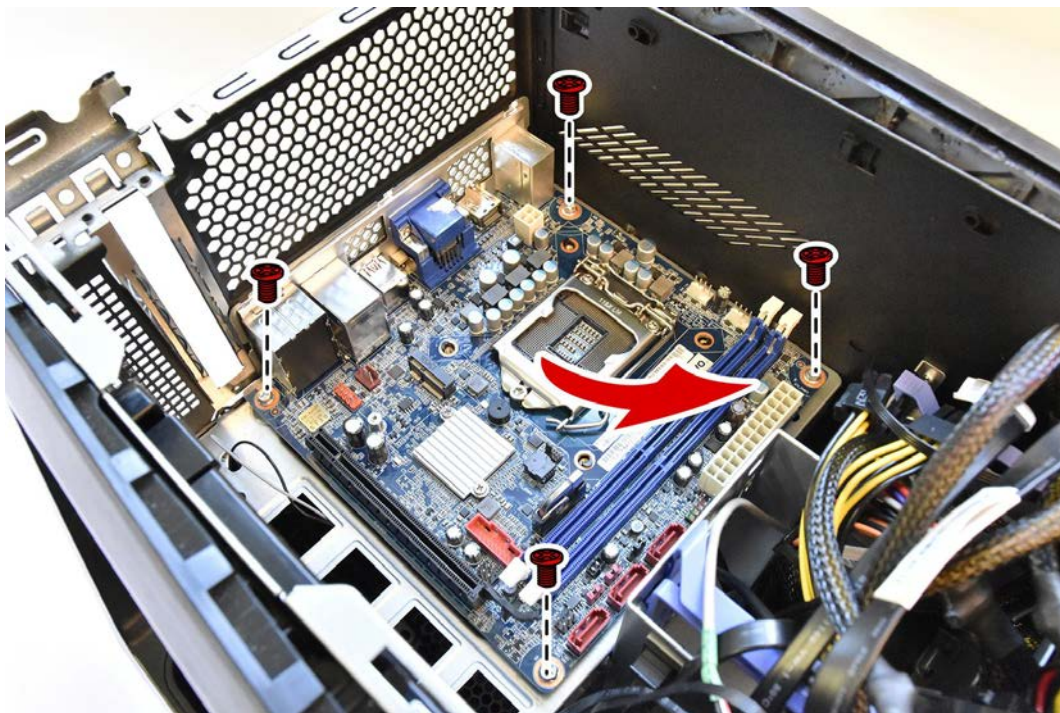



Step 13. Install the new motherboard:

- a. Line up the holes on the new motherboard with mounting holes on the chassis and secure it with screws.
- b. Reattach the memory module, Wi-Fi card, CPU, and the heat-sink assembly to the new motherboard.
- c. Connect the all cables to the new motherboard.
- d. Attach the graphic card to the new motherboard.

Step 14. Reattach the computer cover.

Replacing the front I/O module

Note: For this procedure, it helps to lay the computer flat.

To replace the the front I/O module:

- Step 1. Remove any media (disks, CDs, DVDs, or memory cards) from the drives, shut down the operating system, and turn off the computer and all attached devices.
- Step 2. Unplug all power cords from electrical outlets.
- Step 3. Disconnect all cables attached to the computer. This includes power cords, input/output (I/O) cables, and any other cables that are connected to the computer. Refer to “Left and right view” and “Rear view” for help with locating the various connectors.
- Step 4. Remove the computer cover. Refer to “Removing the computer cover”.
- Step 5. Remove the computer cover(Lenovo logo). Refer to “Removing the computer cover (Lenovo logo)”.
- Step 6. Remove the top cover. Refer to “Removing the top cover”.
- Step 7. Disconnect the data cables from the connectors on motherboard.
- Step 8. Remove the screw that secures the front I/O module to the chassis. **1**
- Step 9. Slide out the front I/O module out of chassis. **2 3**

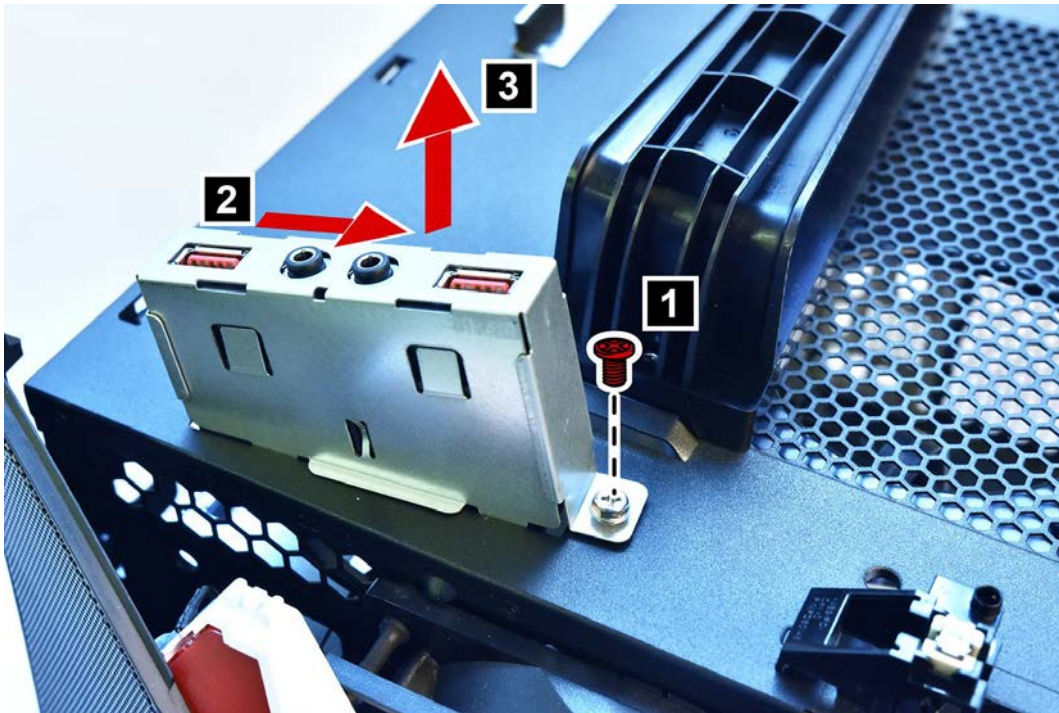

Step 10. Install the new front I/O module:

- a. Slide the front I/O module in and secure it with screw.
- b. Connect the data cables to the motherboard.

Step 11. Reattach the top cover, computer cover and computer cover(Lenovo logo).

FRU lists

This chapter lists the information on the field replaceable units (FRUs).

Attention: Be sure to read and understand all the safety information before replacing any FRUs.

ideacentre Y710 Cube-15ISH Service Parts Listing	
MT: 90FL 90FM	
FruP/N	Description
ANTENNA	
00XJ012	Fru, Lx 250mm Stamping Aux ANT
00XJ011	Fru, Lx 200mm Stamping Main ANT
PLANARS	
00XK063	Y710 USB hub
00XK061	00XK061 for MB FRU NO DPK
00XK062	00XK062 for MB FRU WIN DPK
CABLES	
04X2767	Fru, 390mm sensor cable
00XL156	Fru, 320mm power switch cable
00XL157	Fru200mm SATA cable 2 latch
00XL139	Fru250mm SATA cable 2 latch
00XL134	Fru,Y710 740mm LED cable
00XL136	Fru,520mm USB2.0 AM to AF
00XL117	Fru, 330mm MB to USB Hub cable
00XL159	Fru,100mm 6pin to 8pin cable
CARDPOP	
00KT354	NV GTX750Ti 2G VGA+DVI+HDMI
COVER	
00XD381	WI-FI Cover
DT_KYB	
00PC711	Primax K800 USB gaming KB BLK-US
00UW411	Newmen KB-760 USB KB BLK-US
00PC201	DT_KYB,DOK5321(US)B-Silk USB,US
00UW414	Sunrex EKB-10YA(BR) B-S USB KB
00UW412	Sunrex EKB-10YA(IN) USB KB-LVT
01AH604	EKB-10YA B-S USB,CZ-SL
01AH623	EKB-10YA(EN-FR) B-S USB,EN-FR
01AH605	EKB-10YA(RU) B-Silk USB,RU
01AH603	EKB-10YA(TH) B-Silk USB,TH
01AH614	EKB-10YA(SL) B-Silk USB,SL
01AH626	EKB-10YA B-S USB,US-EU
01AH607	EKB-10YA(Nordic) B-S USB,Nordics
01AH608	EKB-10YA(LA) B-Silk USB,LA
01AH613	EKB-10YA(SP) B-Silk USB,SP

01AH610	EKB-10YA(SW) B-Silk USB,SW
01AH609	EKB-10YA(AR) B-Silk USB,AR
01AH611	EKB-10YA(GE) B-Silk USB,GE
01AH606	EKB-10YA(UK) B-Silk USB,UK
01AH619	EKB-10YA(HG) B-Silk USB,HG
01AH622	EKB-10YA(JP) B-Silk USB,JP
01AH618	EKB-10YA(GK) B-Silk USB,GK
01AH625	EKB-10YA(BE-EN) B-S USB,BE-EN
01AH612	EKB-10YA(TR) B-Silk USB,TR
01AH617	EKB-10YA(FR) B-Silk USB,FR
01AH602	EKB-10YA(TW) B-Silk USB,TW
01AH624	EKB-10YA(PT) B-Silk USB,PT
01AH616	EKB-10YA(HB) B-Silk USB,HB
01AH615	EKB-10YA(IT) B-Silk USB,IT
01AH620	EKB-10YA(BG) B-Silk USB,BG
01AH601	EKB-10YA(US) B-Silk USB,US
01AH621	EKB-10YA(KR) B-Silk USB,KR
00XH687	Newmen K600 USB gaming keyboard B
GMCTRL	
00PH138	Xbx Wrlss Adptr for Win EN/XC/F
00PH137	XbxOne Wrlss Cntrlr L Xbox One
00PH136	XbxOne Wrlss Cntrlr L Xbox One
00PH139	Xbx Wrlss Adptr for Win MultiLa
HDD_ASM	
00PC552	HDD,2TB,7200,DT3,SATA3,STD
00PC551	HDD,1TB,7200,DT3,SATA3,STD
00PC554	SSHS,1TB,7200,DT3,SATA3,STD
45K0625	HDD,2TB,7200,DT3,SATA3,STD
HEATSINK	
01EF258	Gaming Intel LGA1151 Cooler Kit
LINECORD	
00XL020	Fru, LINECORD,IN,1.8M,3P,NON-LH
00XL039	Fru, LINECORD,ZA,1.8M,3P,NON-LH
00XL048	Fru, LINECORD,IT,1.8M,3P,NON-LH
00XL000	Fru, JP,Anti-TR,1.8M,3P,NON-LH
00XL030	Fru, LINECORD,CH,1.8M,3P,NON-LH
00XL028	Fru, LINECORD,IL,1.8M,3P,NON-LH
00XL004	Fru,US/CA,1.8M,3P,NON-LH
00XL017	Fru, LINECORD,TW,1.8M,3P,NON-LH
00XL035	Fru, LINECORD,AR,1.8M,3P,NON-LH

00XL032	Fru, LINECORD,BR,1.8M,3P,NON-LH
00XL029	Fru, LINECORD,CH,1.8M,3P,NON-LH
00XL037	Fru, LINECORD,AR,1.8M,3P,NON-LH
00XL043	Fru, LINECORD,AU,1.8M,3P,NON-LH
00XL009	Fru, LINECORD,CN,1.8M,3P,NON-LH
00XL038	Fru, LINECORD,ZA,1.8M,3P,NON-LH
00XL006	Fru, US/CA,1.8M,3P,NON-LH
00XL023	Fru, LINECORD,GB,1.8M,3P,NON-LH
00XL024	Fru, LINECORD,GB,1.8M,3P,NON-LH
00XL031	Fru, LINECORD,CH,1.8M,3P,NON-LH
00XL042	Fru, LINECORD,AU,1.8M,3P,NON-LH
00XL034	Fru, LINECORD,BR,1.8M,3P,NON-LH
00XL015	Fru, EU/KR,1.8M,3P,NON-LH
00XL049	Fru, LINECORD,IT,1.8M,3P,NON-LH
00XL005	Fru, US/CA,1.8M,3P,NON-LH
00XL040	Fru, LINECORD,ZA,1.8M,3P,NON-LH
00XL016	Fru, EU/KR,1.8M,3P,NON-LH
00XL019	Fru, LINECORD,TW,1.8M,3P,NON-LH
00XL022	Fru, LINECORD,IN,1.8M,3P,NON-LH
00XL041	Fru, LINECORD,AU,1.8M,3P,NON-LH
00XL027	Fru, LINECORD,IL,1.8M,3P,NON-LH
00XL036	Fru, LINECORD,AR,1.8M,3P,NON-LH
00XL001	Fru, JP,Anti-TR,1.8M,3P,NON-LH
00XL018	Fru, LINECORD,TW,1.8M,3P,NON-LH
00XL050	Fru, LINECORD,TH,1.8M,3P,NON-LH
00XL014	Fru, EU/KR,1.8M,3P,NON-LH
00XL046	Fru, LINECORD,DK,1.8M,3P,NON-LH
00XL044	Fru, LINECORD,DK,1.8M,3P,NON-LH
00XL045	Fru, LINECORD,DK,1.8M,3P,NON-LH
00XL010	Fru, LINECORD,CN,1.8M,3P,NON-LH
00XL033	Fru, LINECORD,BR,1.8M,3P,NON-LH
00XL026	Fru, LINECORD,IL,1.8M,3P,NON-LH
00XL047	Fru, LINECORD,IT,1.8M,3P,NON-LH
00XL025	Fru, LINECORD,GB,1.8M,3P,NON-LH
MECH_ASM	
01EF488	703AT,Left Cover Ass'y,Liteon
01EF489	703AT,Right Cover Ass'y,Liteon
01EF486	703AT,Front Cover Ass'y,Liteon
01EF487	703AT,Top Cover Ass'y,Liteon
01EF485	703AT,Bottom Cover Ass'y,Liteon

01EF515	MB Rear IO Shield
MECHANICAL	
01EF332	DVI rubber cover
00XD437	HDMI rubber cover
00XD436	VGA rubber cover
MEMORY	
03T7467	UDIMM,8G,DDR4,2133
03T7466	UDIMM,16G,DDR4,2133
03T7465	UDIMM,4G,DDR4,2133
MOUSE	
00PC712	Primax M800 USB gaming MC black
00PC592	Doking M680B B-Silk USB MC BLK
00UW413	Newmen MS-312 USB MC Black
00PH135	Newmen M600 USB gaming mouse Black
PWR_SUPPLY	
54Y8986	100-240Vac,Y710 280W PSU
54Y8987	100-240Vac,Y710 450W ES PSU
SP	
03T7445	Intel Core i5-6400 2.7G 4C
03T7446	Intel Core i7-6700 3.4G 4C
01AG017	Intel Core i3-6100 3.7G 2C
01AG043	Intel Core i5-6400 2.7G 4C
01AG040	Intel Core i7-6700 3.4G 4C
SSD_ASM	
00KT011	256G,2.5",7mm,SATA6G,SAMSG,STD
00KT045	ASM LIT V2+ 128GB
00KT008	128G,2.5",7mm,SATA6G,SAMSG,STD
00KT046	ASM LIT V2+ 256GB
VIDEO_CARD	
00PC571	NV GTX980 4G DVI/HDMI/3DP
01AG476	MSI R9-370X 4GB 256Bit HP
00PC570	NV GTX970 4G DVI/HDMI/3DP
01AG492	NV@GF GTX1070@8G/DVI/H/3-DP
01AG491	NV@GF GTX1080@8G/DVI/H/3-DP
WIRELESS	
04X6047	Wireless,CMB,LTN,NFA344 Indo
00JT480	Wireless,CMB,IN,8260 ac NV
00JT523	Wireless,CMB,LTN,NFA344 AGN
00JT471	Wireless,CMB,LTN,NFA344 V2

00JT512	Wireless,CMB,FXN,QCA1535
00JT506	Wireless,CMB,IN,8260 NV Ind

Chapter 9. General information

This chapter provides general information that applies to all machine types supported by this publication.

Additional Service Information

This chapter provides additional information that the service representative might find helpful.

Power management

Power management reduces the power consumption of certain components of the computer such as the system power supply, processor, hard disk drives, and some monitors.

Advanced configuration and power interface (ACPI) BIOS

As this computer has an ACPI BIOS system, the operating system is allowed to control the power management features of the computer and the settings for Advanced Power Management (APM) BIOS mode is ignored. Not all operating systems support ACPI BIOS mode.

Automatic Power-On features

The Automatic Power-On features within the Power Management menu allow you to enable and disable features that turn on the computer automatically.

- **Wake Up on Alarm:** You can specify a date and time at which the computer will be turned on automatically. This can be either a single event, a daily event or a weekly event.
- **Wake Up on LAN:** This feature allows LAN adapter card to wake the System.