

HP ProLiant DL320e Gen8 v2 Server Maintenance and Service Guide

Abstract

This guide describes identification and maintenance procedures, diagnostic tools, specifications and requirements for hardware components and software. This guide is for an experienced service technician. HP assumes you are qualified in the servicing of computer equipment, trained in recognizing hazards in products, and are familiar with weight and stability precautions.



Part Number: 718996-005
July 2014
Edition: 5

© Copyright 2013, 2014 Hewlett-Packard Development Company, L.P.

The information contained herein is subject to change without notice. The only warranties for HP products and services are set forth in the express warranty statements accompanying such products and services. Nothing herein should be construed as constituting an additional warranty. HP shall not be liable for technical or editorial errors or omissions contained herein.

Microsoft® and Windows® are U.S. registered trademarks of Microsoft Corporation.

Intel®, Pentium®, Core®, and Xeon® are trademarks of Intel Corporation in the U.S. and other countries.

Contents

Customer self repair	6
Parts only warranty service.....	6
Illustrated parts catalog	16
Mechanical components	16
System components	19
Removal and replacement procedures	25
Required tools.....	25
Safety considerations.....	25
Preventing electrostatic discharge	25
Symbols on equipment.....	25
Server warnings and cautions.....	26
Rack warnings	27
Preparation procedures.....	27
Remove the security bezel (optional).....	28
Power down the server	28
Extend the server from the rack.....	29
Remove the server from the rack	30
Rack mount ears.....	30
Hot-plug drive blank	31
Hot-plug drive	32
Rack rail cable ties	32
HP CS power supply	33
Non-hot-plug drive carrier	34
Non-hot-plug drive.....	34
Access panel	35
Air baffle.....	36
Optical drive	37
Mini-SAS cable	38
Drive cage assembly	39
Hot-plug drive cage backplane.....	41
Non-hot-plug drive cage bracket.....	42
Front I/O module assembly.....	43
Front fan cage assembly	43
DIMMs.....	44
Heatsink.....	45
Processor.....	47
System battery	50
PCI riser cage	51
Expansion board options	52
PCIe riser board.....	53
Flash-backed write cache procedures	54
FBWC module	54
Capacitor pack.....	55
Recovering data from the flash-backed write cache.....	57
Center fan assembly	58

Internal USB connector.....	59
Integrated power supply rear cover.....	60
Integrated power supply	61
HP 750 W CS -48 V DC power supply enablement kit.....	62
HP CS power supply cage	63
System board	64
HP Trusted Platform Module.....	70
Troubleshooting	71
Troubleshooting resources	71
Diagnostic tools	72
HP product QuickSpecs	72
HP Insight Diagnostics	72
HP Insight Diagnostics survey functionality	72
HP Insight Remote Support software	72
HP ROM-Based Setup Utility	73
Integrated Management Log.....	73
USB support and functionality.....	73
USB support	73
Internal USB functionality	74
External USB functionality	74
Automatic Server Recovery.....	74
Component identification.....	75
Front panel components.....	75
Front panel LEDs and buttons.....	76
Rear panel components	76
Rear panel LEDs and buttons	77
PCIe riser board slot definitions	77
System board components	78
DIMM slot locations.....	79
System maintenance switch	79
NMI functionality	80
Drive numbering	80
Hot-plug drive LED definitions.....	80
FBWC module LED definitions	81
Fan locations	82
Cabling	83
Cabling overview.....	83
Storage cabling	83
Two-bay LFF non-hot-plug drive cage cabling	83
Two-bay LFF hot-plug drive cage cabling	84
Four-bay SFF hot-plug drive cage cabling (AC power supply)	85
Optical drive cabling.....	88
Power supply cabling	89
HP 250 W Integrated Power Supply cabling.....	89
HP 300 W Integrated Power Supply cabling.....	90
HP 750 W CS -48 V DC Power Supply (with PDB) cabling.....	92
Internal USB cabling.....	92
Front I/O board cabling	93
Specifications.....	94
Environmental specifications.....	94

Server specifications	94
Power supply specifications	94
HP 250 W Integrated Power Supply	94
HP 300 W Integrated Power Supply	95
HP 750 W CS -48 V DC Power Supply (94% efficiency)	95
Acronyms and abbreviations	97
Documentation feedback	100
Index	101

Customer self repair

HP products are designed with many Customer Self Repair (CSR) parts to minimize repair time and allow for greater flexibility in performing defective parts replacement. If during the diagnosis period HP (or HP service providers or service partners) identifies that the repair can be accomplished by the use of a CSR part, HP will ship that part directly to you for replacement. There are two categories of CSR parts:

- **Mandatory**—Parts for which customer self repair is mandatory. If you request HP to replace these parts, you will be charged for the travel and labor costs of this service.
- **Optional**—Parts for which customer self repair is optional. These parts are also designed for customer self repair. If, however, you require that HP replace them for you, there may or may not be additional charges, depending on the type of warranty service designated for your product.

NOTE: Some HP parts are not designed for customer self repair. In order to satisfy the customer warranty, HP requires that an authorized service provider replace the part. These parts are identified as "No" in the Illustrated Parts Catalog.

Based on availability and where geography permits, CSR parts will be shipped for next business day delivery. Same day or four-hour delivery may be offered at an additional charge where geography permits. If assistance is required, you can call the HP Technical Support Center and a technician will help you over the telephone. HP specifies in the materials shipped with a replacement CSR part whether a defective part must be returned to HP. In cases where it is required to return the defective part to HP, you must ship the defective part back to HP within a defined period of time, normally five (5) business days. The defective part must be returned with the associated documentation in the provided shipping material. Failure to return the defective part may result in HP billing you for the replacement. With a customer self repair, HP will pay all shipping and part return costs and determine the courier/carrier to be used.

For more information about HP's Customer Self Repair program, contact your local service provider. For the North American program, refer to the HP website (<http://www.hp.com/go/selfrepair>).

Parts only warranty service

Your HP Limited Warranty may include a parts only warranty service. Under the terms of parts only warranty service, HP will provide replacement parts free of charge.

For parts only warranty service, CSR part replacement is mandatory. If you request HP to replace these parts, you will be charged for the travel and labor costs of this service.

Réparation par le client (CSR)

Les produits HP comportent de nombreuses pièces CSR (Customer Self Repair = réparation par le client) afin de minimiser les délais de réparation et faciliter le remplacement des pièces défectueuses. Si pendant la période de diagnostic, HP (ou ses partenaires ou mainteneurs agréés) détermine que la réparation peut être effectuée à l'aide d'une pièce CSR, HP vous l'envoie directement. Il existe deux catégories de pièces CSR:

Obligatoire - Pièces pour lesquelles la réparation par le client est obligatoire. Si vous demandez à HP de remplacer ces pièces, les coûts de déplacement et main d'œuvre du service vous seront facturés.

Facultatif - Pièces pour lesquelles la réparation par le client est facultative. Ces pièces sont également conçues pour permettre au client d'effectuer lui-même la réparation. Toutefois, si vous demandez à HP de remplacer ces pièces, l'intervention peut ou non vous être facturée, selon le type de garantie applicable à votre produit.

REMARQUE: Certaines pièces HP ne sont pas conçues pour permettre au client d'effectuer lui-même la réparation. Pour que la garantie puisse s'appliquer, HP exige que le remplacement de la pièce soit effectué par un Mainteneur Agréé. Ces pièces sont identifiées par la mention "Non" dans le Catalogue illustré.

Les pièces CSR sont livrées le jour ouvré suivant, dans la limite des stocks disponibles et selon votre situation géographique. Si votre situation géographique le permet et que vous demandez une livraison le jour même ou dans les 4 heures, celle-ci vous sera facturée. Pour bénéficier d'une assistance téléphonique, appelez le Centre d'assistance technique HP. Dans les documents envoyés avec la pièce de rechange CSR, HP précise s'il est nécessaire de lui retourner la pièce défectueuse. Si c'est le cas, vous devez le faire dans le délai indiqué, généralement cinq (5) jours ouvrés. La pièce et sa documentation doivent être retournées dans l'emballage fourni. Si vous ne retournez pas la pièce défectueuse, HP se réserve le droit de vous facturer les coûts de remplacement. Dans le cas d'une pièce CSR, HP supporte l'ensemble des frais d'expédition et de retour, et détermine la société de courses ou le transporteur à utiliser.

Pour plus d'informations sur le programme CSR de HP, contactez votre Mainteneur Agréé local. Pour plus d'informations sur ce programme en Amérique du Nord, consultez le site Web HP (<http://www.hp.com/go/selfrepair>).

Service de garantie "pièces seules"

Votre garantie limitée HP peut inclure un service de garantie "pièces seules". Dans ce cas, les pièces de rechange fournies par HP ne sont pas facturées.

Dans le cadre de ce service, la réparation des pièces CSR par le client est obligatoire. Si vous demandez à HP de remplacer ces pièces, les coûts de déplacement et main d'œuvre du service vous seront facturés.

Riparazione da parte del cliente

Per abbreviare i tempi di riparazione e garantire una maggiore flessibilità nella sostituzione di parti difettose, i prodotti HP sono realizzati con numerosi componenti che possono essere riparati direttamente dal cliente (CSR, Customer Self Repair). Se in fase di diagnostica HP (o un centro di servizi o di assistenza HP) identifica il guasto come riparabile mediante un ricambio CSR, HP lo spedisce direttamente al cliente per la sostituzione. Vi sono due categorie di parti CSR:

Obbligatorie – Parti che devono essere necessariamente riparate dal cliente. Se il cliente ne affida la riparazione ad HP, deve sostenere le spese di spedizione e di manodopera per il servizio.

Opzionali – Parti la cui riparazione da parte del cliente è facoltativa. Si tratta comunque di componenti progettati per questo scopo. Se tuttavia il cliente ne richiede la sostituzione ad HP, potrebbe dover sostenere spese aggiuntive a seconda del tipo di garanzia previsto per il prodotto.

NOTA: alcuni componenti HP non sono progettati per la riparazione da parte del cliente. Per rispettare la garanzia, HP richiede che queste parti siano sostituite da un centro di assistenza autorizzato. Tali parti sono identificate da un "No" nel Catalogo illustrato dei componenti.

In base alla disponibilità e alla località geografica, le parti CSR vengono spedite con consegna entro il giorno lavorativo seguente. La consegna nel giorno stesso o entro quattro ore è offerta con un supplemento di costo solo in alcune zone. In caso di necessità si può richiedere l'assistenza telefonica di un addetto del centro di supporto tecnico HP. Nel materiale fornito con una parte di ricambio CSR, HP specifica se il cliente deve restituire dei componenti. Qualora sia richiesta la resa ad HP del componente difettoso, lo si deve spedire ad HP entro un determinato periodo di tempo, generalmente cinque (5) giorni lavorativi. Il componente difettoso deve essere restituito con la documentazione associata nell'imballo di spedizione fornito. La mancata restituzione del componente può comportare la fatturazione del ricambio da parte di HP. Nel caso di riparazione da parte del cliente, HP sostiene tutte le spese di spedizione e resa e sceglie il corriere/vettore da utilizzare.

Per ulteriori informazioni sul programma CSR di HP contattare il centro di assistenza di zona. Per il programma in Nord America fare riferimento al sito Web HP (<http://www.hp.com/go/selfrepair>).

Servizio di garanzia per i soli componenti

La garanzia limitata HP può includere un servizio di garanzia per i soli componenti. Nei termini di garanzia del servizio per i soli componenti, HP fornirà gratuitamente le parti di ricambio.

Per il servizio di garanzia per i soli componenti è obbligatoria la formula CSR che prevede la riparazione da parte del cliente. Se il cliente invece richiede la sostituzione ad HP, dovrà sostenere le spese di spedizione e di manodopera per il servizio.

Customer Self Repair

HP Produkte enthalten viele CSR-Teile (Customer Self Repair), um Reparaturzeiten zu minimieren und höhere Flexibilität beim Austausch defekter Bauteile zu ermöglichen. Wenn HP (oder ein HP Servicepartner) bei der Diagnose feststellt, dass das Produkt mithilfe eines CSR-Teils repariert werden kann, sendet Ihnen HP dieses Bauteil zum Austausch direkt zu. CSR-Teile werden in zwei Kategorien unterteilt:

Zwingend – Teile, für die das Customer Self Repair-Verfahren zwingend vorgegeben ist. Wenn Sie den Austausch dieser Teile von HP vornehmen lassen, werden Ihnen die Anfahrt- und Arbeitskosten für diesen Service berechnet.

Optional – Teile, für die das Customer Self Repair-Verfahren optional ist. Diese Teile sind auch für Customer Self Repair ausgelegt. Wenn Sie jedoch den Austausch dieser Teile von HP vornehmen lassen möchten, können bei diesem Service je nach den für Ihr Produkt vorgesehenen Garantiebedingungen zusätzliche Kosten anfallen.

HINWEIS: Einige Teile sind nicht für Customer Self Repair ausgelegt. Um den Garantieanspruch des Kunden zu erfüllen, muss das Teil von einem HP Servicepartner ersetzt werden. Im illustrierten Teilekatalog sind diese Teile mit „No“ bzw. „Nein“ gekennzeichnet.

CSR-Teile werden abhängig von der Verfügbarkeit und vom Lieferziel am folgenden Geschäftstag geliefert. Für bestimmte Standorte ist eine Lieferung am selben Tag oder innerhalb von vier Stunden gegen einen Aufpreis verfügbar. Wenn Sie Hilfe benötigen, können Sie das HP technische Support Center anrufen und sich von einem Mitarbeiter per Telefon helfen lassen. Den Materialien, die mit einem CSR-Ersatzteil geliefert werden, können Sie entnehmen, ob das defekte Teil an HP zurückgeschickt werden muss. Wenn es erforderlich ist, das defekte Teil an HP zurückzuschicken, müssen Sie dies innerhalb eines vorgegebenen Zeitraums tun, in der Regel innerhalb von fünf (5) Geschäftstagen. Das defekte Teil muss mit der zugehörigen Dokumentation in der Verpackung zurückgeschickt werden, die im Lieferumfang enthalten ist. Wenn Sie das

defekte Teil nicht zurückschicken, kann HP Ihnen das Ersatzteil in Rechnung stellen. Im Falle von Customer Self Repair kommt HP für alle Kosten für die Lieferung und Rücksendung auf und bestimmt den Kurier-/Frachtdienst.

Weitere Informationen über das HP Customer Self Repair Programm erhalten Sie von Ihrem Servicepartner vor Ort. Informationen über das CSR-Programm in Nordamerika finden Sie auf der HP Website unter (<http://www.hp.com/go/selfrepair>).

Parts-only Warranty Service (Garantieservice ausschließlich für Teile)

Ihre HP Garantie umfasst möglicherweise einen Parts-only Warranty Service (Garantieservice ausschließlich für Teile). Gemäß den Bestimmungen des Parts-only Warranty Service stellt HP Ersatzteile kostenlos zur Verfügung.

Für den Parts-only Warranty Service ist das CSR-Verfahren zwingend vorgegeben. Wenn Sie den Austausch dieser Teile von HP vornehmen lassen, werden Ihnen die Anfahrt- und Arbeitskosten für diesen Service berechnet.

Reparaciones del propio cliente

Los productos de HP incluyen muchos componentes que el propio usuario puede reemplazar (*Customer Self Repair*, CSR) para minimizar el tiempo de reparación y ofrecer una mayor flexibilidad a la hora de realizar sustituciones de componentes defectuosos. Si, durante la fase de diagnóstico, HP (o los proveedores o socios de servicio de HP) identifica que una reparación puede llevarse a cabo mediante el uso de un componente CSR, HP le enviará dicho componente directamente para que realice su sustitución. Los componentes CSR se clasifican en dos categorías:

- **Obligatorio:** componentes para los que la reparación por parte del usuario es obligatoria. Si solicita a HP que realice la sustitución de estos componentes, tendrá que hacerse cargo de los gastos de desplazamiento y de mano de obra de dicho servicio.
- **Opcional:** componentes para los que la reparación por parte del usuario es opcional. Estos componentes también están diseñados para que puedan ser reparados por el usuario. Sin embargo, si precisa que HP realice su sustitución, puede o no conllevar costes adicionales, dependiendo del tipo de servicio de garantía correspondiente al producto.

NOTA: Algunos componentes no están diseñados para que puedan ser reparados por el usuario. Para que el usuario haga valer su garantía, HP pone como condición que un proveedor de servicios autorizado realice la sustitución de estos componentes. Dichos componentes se identifican con la palabra "No" en el catálogo ilustrado de componentes.

Según la disponibilidad y la situación geográfica, los componentes CSR se enviarán para que lleguen a su destino al siguiente día laborable. Si la situación geográfica lo permite, se puede solicitar la entrega en el mismo día o en cuatro horas con un coste adicional. Si precisa asistencia técnica, puede llamar al Centro de asistencia técnica de HP y recibirá ayuda telefónica por parte de un técnico. Con el envío de materiales para la sustitución de componentes CSR, HP especificará si los componentes defectuosos deberán devolverse a HP. En aquellos casos en los que sea necesario devolver algún componente a HP, deberá hacerlo en el periodo de tiempo especificado, normalmente cinco días laborables. Los componentes defectuosos deberán devolverse con toda la documentación relacionada y con el embalaje de envío. Si no

enviara el componente defectuoso requerido, HP podrá cobrarle por el de sustitución. En el caso de todas sustituciones que lleve a cabo el cliente, HP se hará cargo de todos los gastos de envío y devolución de componentes y escogerá la empresa de transporte que se utilice para dicho servicio.

Para obtener más información acerca del programa de Reparaciones del propio cliente de HP, póngase en contacto con su proveedor de servicios local. Si está interesado en el programa para Norteamérica, visite la página web de HP siguiente (<http://www.hp.com/go/selfrepair>).

Servicio de garantía exclusivo de componentes

La garantía limitada de HP puede que incluya un servicio de garantía exclusivo de componentes. Según las condiciones de este servicio exclusivo de componentes, HP le facilitará los componentes de repuesto sin cargo adicional alguno.

Para este servicio de garantía exclusivo de componentes, es obligatoria la sustitución de componentes por parte del usuario (CSR). Si solicita a HP que realice la sustitución de estos componentes, tendrá que hacerse cargo de los gastos de desplazamiento y de mano de obra de dicho servicio.

Customer Self Repair

Veel onderdelen in HP producten zijn door de klant zelf te repareren, waardoor de reparatieduur tot een minimum beperkt kan blijven en de flexibiliteit in het vervangen van defecte onderdelen groter is. Deze onderdelen worden CSR-onderdelen (Customer Self Repair) genoemd. Als HP (of een HP Service Partner) bij de diagnose vaststelt dat de reparatie kan worden uitgevoerd met een CSR-onderdeel, verzendt HP dat onderdeel rechtstreeks naar u, zodat u het defecte onderdeel daarmee kunt vervangen. Er zijn twee categorieën CSR-onderdelen:

Verplicht: Onderdelen waarvoor reparatie door de klant verplicht is. Als u HP verzoekt deze onderdelen voor u te vervangen, worden u voor deze service reiskosten en arbeidsloon in rekening gebracht.

Optioneel: Onderdelen waarvoor reparatie door de klant optioneel is. Ook deze onderdelen zijn ontworpen voor reparatie door de klant. Als u echter HP verzoekt deze onderdelen voor u te vervangen, kunnen daarvoor extra kosten in rekening worden gebracht, afhankelijk van het type garantieservice voor het product.

OPMERKING: Sommige HP onderdelen zijn niet ontwikkeld voor reparatie door de klant. In verband met de garantievoorwaarden moet het onderdeel door een geautoriseerde Service Partner worden vervangen. Deze onderdelen worden in de geïllustreerde onderdelencatalogus aangemerkt met "Nee".

Afhankelijk van de leverbaarheid en de locatie worden CSR-onderdelen verzonden voor levering op de eerstvolgende werkdag. Levering op dezelfde dag of binnen vier uur kan tegen meerkosten worden aangeboden, indien dit mogelijk is gezien de locatie. Indien assistentie gewenst is, belt u een HP Service Partner om via de telefoon technische ondersteuning te ontvangen. HP vermeldt in de documentatie bij het vervangende CSR-onderdeel of het defecte onderdeel aan HP moet worden geretourneerd. Als het defecte onderdeel aan HP moet worden teruggezonden, moet u het defecte onderdeel binnen een bepaalde periode, gewoonlijk vijf (5) werkdagen, retourneren aan HP. Het defecte onderdeel moet met de bijbehorende documentatie worden geretourneerd in het meegeleverde verpakkingsmateriaal. Als u het defecte onderdeel niet terugzendt, kan HP u voor het vervangende onderdeel kosten in rekening brengen. Bij reparatie door de klant betaalt HP alle verzendkosten voor het vervangende en geretourneerde onderdeel en kiest HP zelf welke koerier/transportonderneming hiervoor wordt gebruikt.

Neem contact op met een Service Partner voor meer informatie over het Customer Self Repair programma van HP. Informatie over Service Partners vindt u op de HP website (<http://www.hp.com/go/selfrepair>).

Garantieservice "Parts Only"

Het is mogelijk dat de HP garantie alleen de garantieservice "Parts Only" omvat. Volgens de bepalingen van de Parts Only garantieservice zal HP kosteloos vervangende onderdelen ter beschikking stellen.

Voor de Parts Only garantieservice is vervanging door CSR-onderdelen verplicht. Als u HP verzoekt deze onderdelen voor u te vervangen, worden u voor deze service reiskosten en arbeidsloon in rekening gebracht.

Reparo feito pelo cliente

Os produtos da HP são projetados com muitas peças para reparo feito pelo cliente (CSR) de modo a minimizar o tempo de reparo e permitir maior flexibilidade na substituição de peças com defeito. Se, durante o período de diagnóstico, a HP (ou fornecedores/parceiros de serviço da HP) concluir que o reparo pode ser efetuado pelo uso de uma peça CSR, a peça de reposição será enviada diretamente ao cliente. Existem duas categorias de peças CSR:

Obrigatória – Peças cujo reparo feito pelo cliente é obrigatório. Se desejar que a HP substitua essas peças, serão cobradas as despesas de transporte e mão-de-obra do serviço.

Opcional – Peças cujo reparo feito pelo cliente é opcional. Essas peças também são projetadas para o reparo feito pelo cliente. No entanto, se desejar que a HP as substitua, pode haver ou não a cobrança de taxa adicional, dependendo do tipo de serviço de garantia destinado ao produto.

OBSERVAÇÃO: Algumas peças da HP não são projetadas para o reparo feito pelo cliente. A fim de cumprir a garantia do cliente, a HP exige que um técnico autorizado substitua a peça. Essas peças estão identificadas com a marca "No" (Não), no catálogo de peças ilustrado.

Conforme a disponibilidade e o local geográfico, as peças CSR serão enviadas no primeiro dia útil após o pedido. Onde as condições geográficas permitirem, a entrega no mesmo dia ou em quatro horas pode ser feita mediante uma taxa adicional. Se precisar de auxílio, entre em contato com o Centro de suporte técnico da HP para que um técnico o ajude por telefone. A HP especifica nos materiais fornecidos com a peça CSR de reposição se a peça com defeito deve ser devolvida à HP. Nos casos em que isso for necessário, é preciso enviar a peça com defeito à HP dentro do período determinado, normalmente cinco (5) dias úteis. A peça com defeito deve ser enviada com a documentação correspondente no material de transporte fornecido. Caso não o faça, a HP poderá cobrar a reposição. Para as peças de reparo feito pelo cliente, a HP paga todas as despesas de transporte e de devolução da peça e determina a transportadora/serviço postal a ser utilizado.

Para obter mais informações sobre o programa de reparo feito pelo cliente da HP, entre em contato com o fornecedor de serviços local. Para o programa norte-americano, visite o site da HP (<http://www.hp.com/go/selfrepair>).

Serviço de garantia apenas para peças

A garantia limitada da HP pode incluir um serviço de garantia apenas para peças. Segundo os termos do serviço de garantia apenas para peças, a HP fornece as peças de reposição sem cobrar nenhuma taxa.

No caso desse serviço, a substituição de peças CSR é obrigatória. Se desejar que a HP substitua essas peças, serão cobradas as despesas de transporte e mão-de-obra do serviço.

カスタマーセルフリペア

修理時間を短縮し、故障部品の交換における高い柔軟性を確保するために、HP製品には多数のCSR部品があります。診断の際に、CSR部品を使用すれば修理ができるとHP（HPまたはHP正規保守代理店）が判断した場合、HPはその部品を直接、お客様に発送し、お客様に交換していただきます。CSR部品には以下の2通りがあります。

- **必須** - カスタマーセルフリペアが必須の部品。当該部品について、もしもお客様がHPに交換作業を依頼される場合には、その修理サービスに関する交通費および人件費がお客様に請求されます。
- **任意** - カスタマーセルフリペアが任意である部品。この部品もカスタマーセルフリペア用です。当該部品について、もしもお客様がHPに交換作業を依頼される場合には、お買い上げの製品に適用される保証サービス内容の範囲内においては、別途費用を負担していただくことなく保証サービスを受けることができます。

注： HP製品の一部の部品は、カスタマーセルフリペア用ではありません。製品の保証を継続するためには、HPまたはHP正規保守代理店による交換作業が必須となります。部品カタログには、当該部品がカスタマーセルフリペア除外品である旨が記載されています。

部品供給が可能な場合、地域によっては、CSR部品を翌営業日に届くように発送します。また、地域によっては、追加費用を負担いただくことにより同日または4時間以内に届くように発送することも可能な場合があります。サポートが必要なときは、HPの修理受付窓口にご電話いただければ、技術者が電話でアドバイスします。交換用のCSR部品または同梱物には、故障部品をHPに返送する必要があるかどうかが表示されています。故障部品をHPに返送する必要がある場合は、指定期限内（通常は5営業日以内）に故障部品をHPに返送してください。故障部品を返送する場合は、届いた時の梱包箱に関連書類とともに入れてください。故障部品を返送しない場合、HPから部品費用が請求されます。カスタマーセルフリペアの際には、HPは送料および部品返送費を全額負担し、使用する宅配便会社や運送会社を指定します。

部品のみ保証サービス

HP保証サービスには、部品のみ保証サービスが適用される場合があります。このサービスでは、交換部品は無償で提供されます。

部品のみ保証サービスにおいては、CSR部品をお客様により交換作業していただくことが必須となります。当該部品について、もしもお客様がHPに交換作業を依頼される場合には、その修理サービスに関する交通費および人件費はお客様の負担となります。

客户自行维修

HP 产品提供许多客户自行维修 (CSR) 部件，以尽可能缩短维修时间和在更换缺陷部件方面提供更大的灵活性。如果在诊断期间 HP（或 HP 服务提供商或服务合作伙伴）确定可以通过使用 CSR 部件完成维修，HP 将直接把该部件发送给您进行更换。有两类 CSR 部件：

- **强制性的** — 要求客户必须自行维修的部件。如果您请求 HP 更换这些部件，则必须为该服务支付差旅费和人工费用。
- **可选的** — 客户可以选择是否自行维修的部件。这些部件也是为客户自行维修设计的。不过，如果您要求 HP 为您更换这些部件，则根据您的产品指定的保修服务类型，HP 可能收取或不再收取任何附加费用。

注：某些 HP 部件的设计并未考虑客户自行维修。为了满足客户保修的需要，HP 要求授权服务提供商更换相关部件。这些部件在部件图解目录中标记为“否”。

CSR 部件将在下一个工作日发运（取决于备货情况和允许的地理范围）。在允许的地理范围内，可在当天或四小时内发运，但要收取额外费用。如果需要帮助，您可以致电 HP 技术支持中心，将会有技术人员通过电话为您提供帮助。HP 会在随更换的 CSR 部件发运的材料中指明是否必须将有缺陷的部件返还给 HP。如果要求您将有缺陷的部件返还给 HP，那么您必须在规定期限内（通常是五 (5) 个工作日）将缺陷部件发给 HP。有缺陷的部件必须随所提供的发运材料中的相关文件一起返还。如果未能送还缺陷的部件，HP 可能会要求您支付更换费用。客户自行维修时，HP 将承担所有相关运输和部件返回费用，并指定快递商/承运商。

有关 HP 客户自行维修计划的详细信息，请与您当地的服务提供商联系。有关北美地区的计划，请访问 HP 网站 (<http://www.hp.com/go/selfrepair>)。

仅部件保修服务

您的 HP 有限保修服务可能涉及仅部件保修服务。根据仅部件保修服务条款的规定，HP 将免费提供更换的部件。

仅部件保修服务要求进行 CSR 部件更换。如果您请求 HP 更换这些部件，则必须为该服务支付差旅费和人工费用。

客戶自行維修

HP 產品設計了許多「客戶自行維修」(CSR) 的零件以減少維修時間，並且使得更換瑕疵零件時能有更大的彈性。如果在診斷期間 HP (或 HP 服務供應商或維修夥伴) 辨認出此項維修工作可以藉由使用 CSR 零件來完成，則 HP 將直接寄送該零件給您作更換。CSR 零件分為兩種類別：

- **強制的** — 客戶自行維修所使用的零件是強制性的。如果您要求 HP 更換這些零件，HP 將會向您收取此服務所需的外出費用與勞動成本。
- **選購的** — 客戶自行維修所使用的零件是選購的。這些零件也設計用於客戶自行維修之用。不過，如果您要求 HP 為您更換，則可能需要也可能不需要負擔額外的費用，端視針對此產品指定的保固服務類型而定。

備註：某些 HP 零件沒有消費者可自行維修的設計。為符合客戶保固，HP 需要授權的服務供應商更換零件。這些零件在圖示的零件目錄中，被標示為「否」。

基於材料取得及環境允許的情況下，CSR 零件將於下一個工作日以快遞寄送。在環境的允許下當天或四小時內送達，則可能需要額外的費用。若您需要協助，可致電「HP 技術支援中心」，會有一位技術人員透過電話來協助您。不論損壞的零件是否必須退回，HP 皆會在與 CSR 替換零件一起運送的材料中註明。若要將損壞的零件退回 HP，您必須在指定的一段時間內（通常為五 (5) 個工作天），將損壞的零件寄回 HP。損壞的零件必須與寄送資料中隨附的相關技術文件一併退還。如果無法退還損壞的零件，HP 可能要向您收取替換費用。針對客戶自行維修情形，HP 將負責所有運費及零件退還費用並指定使用何家快遞/貨運公司。

如需 HP 的「客戶自行維修」方案詳細資訊，請連絡您當地的服務供應商。至於北美方案，請參閱 HP 網站 (<http://www.hp.com/go/selfrepair>)。

僅限零件的保固服務

您的「HP 有限保固」可能包含僅限零件的保固服務。在僅限零件的保固服務情況下，HP 將免費提供替換零件。

針對僅限零件的保固服務，CSR 零件替換是強制性的。如果您要求 HP 更換這些零件，HP 將會向您收取此服務所需的外出費用與勞動成本。

고객 셀프 수리

HP 제품은 수리 시간을 최소화하고 결함이 있는 부품 교체 시 더욱 융통성을 발휘할 수 있도록 하기 위해 고객 셀프 수리(CSR) 부품을 다량 사용하여 설계되었습니다. 진단 기간 동안 HP(또는 HP 서비스 공급업체 또는 서비스 협력업체)에서 CSR 부품을 사용하여 수리가 가능하다고 판단되면 HP는 해당 부품을 바로 사용자에게 보내어 사용자가 교체할 수 있도록 합니다. CSR 부품에는 두 가지 종류가 있습니다.

- **고객 셀프 수리가 의무 사항인 필수 부품.** 사용자가 HP에 이 부품의 교체를 요청할 경우 이 서비스에 대한 출장비 및 작업비가 청구됩니다.
- **고객 셀프 수리가 선택 사항인 부품.** 이 부품들도 고객 셀프 수리가 가능하도록 설계되었습니다. 하지만 사용자가 HP에 이 부품의 교체를 요청할 경우 사용자가 구입한 제품에 해당하는 보증 서비스 유형에 따라 추가 비용 없이 교체가 가능할 수 있습니다.

참고: 일부 HP 부품은 고객 셀프 수리가 불가능하도록 설계되었습니다. HP는 만족스러운 고객 보증을 위해 공인 서비스 제공업체를 통해 부품을 교체하도록 하고 있습니다. 이러한 부품들은 Illustrated Parts Catalog에 "No"라고 표시되어 있습니다.

CSR 부품은 재고 상태와 지리적 조건이 허용하는 경우 다음 영업일 납품이 가능하도록 배송이 이루어집니다. 지리적 조건이 허용하는 경우 추가 비용이 청구되는 조건으로 당일 또는 4시간 배송이 가능할 수도 있습니다. 도움이 필요하시면 HP 기술 지원 센터로 전화하십시오. 전문 기술자가 전화로 도움을 줄 것입니다. HP는 결함이 발생한 부품을 HP로 반환해야 하는지 여부를 CSR 교체 부품과 함께 배송된 자료에 지정합니다. 결함이 발생한 부품을 HP로 반환해야 하는 경우에는 지정된 기간 내(통상 영업일 기준 5일)에 HP로 반환해야 합니다. 이 때 결함이 발생한 부품은 제공된 포장 재료에 넣어 관련 설명서와 함께 반환해야 합니다. 결함이 발생한 부품을 반환하지 않는 경우 HP가 교체 부품에 대해 비용을 청구할 수 있습니다. 고객 셀프 수리의 경우, HP는 모든 운송 및 부품 반환 비용을 부담하며 이용할 운송업체 및 택배 서비스를 결정합니다.

HP 고객 셀프 수리 프로그램에 대한 자세한 내용은 가까운 서비스 제공업체에 문의하십시오. 북미 지역의 프로그램에 대해서는 HP 웹 사이트(<http://www.hp.com/go/selfrepair>)를 참조하십시오.

부품 제공 보증 서비스

HP 제한 보증에는 부품 제공 보증 서비스가 포함될 수 있습니다. 이러한 경우 HP는 부품 제공 보증 서비스의 조건에 따라 교체 부품만을 무료로 제공합니다.

부품 제공 보증 서비스 제공 시 CSR 부품 교체는 의무 사항입니다. 사용자가 HP에 이 부품의 교체를 요청할 경우 이 서비스에 대한 출장비 및 작업비가 청구됩니다.

Illustrated parts catalog

Mechanical components

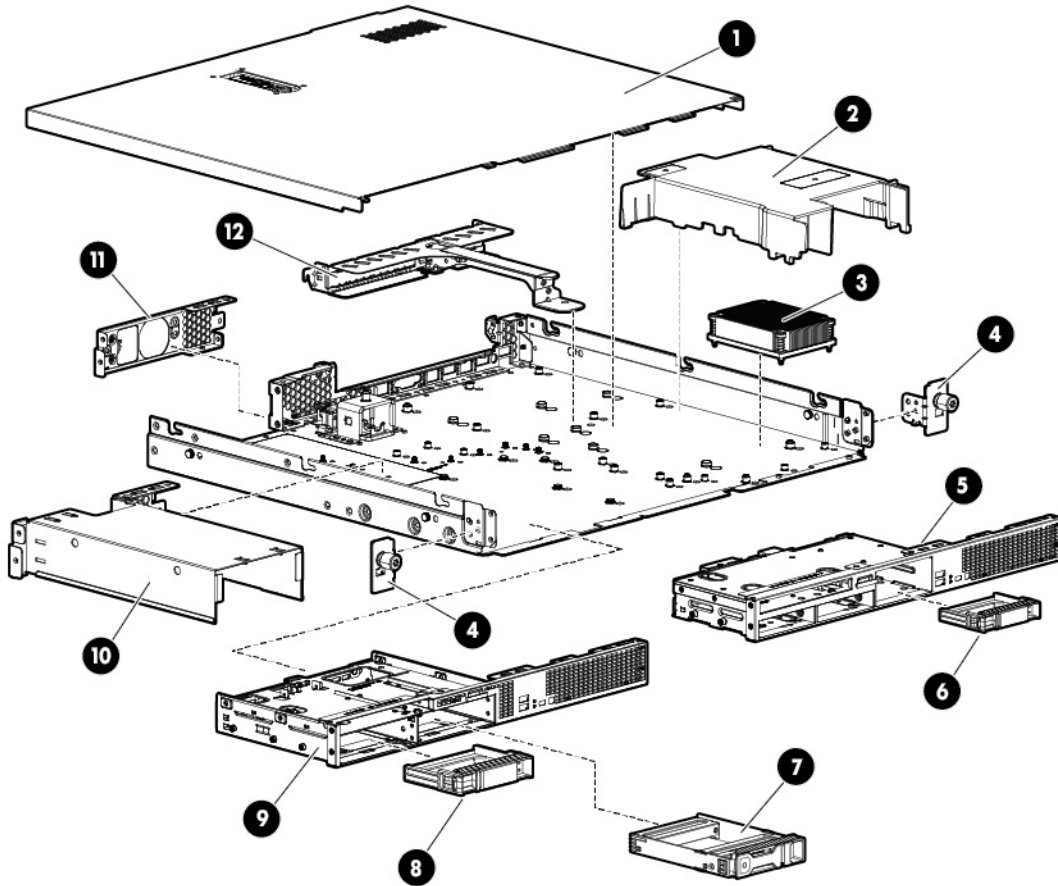

Item	Description	Spare part number	Customer self repair (on page 6)
1	Access panel	725261-001	Mandatory ¹
2	Air baffle	725262-001	Mandatory ¹
3	Heatsink	687242-001	Optional ²
4	Thumbscrew type rack ears	725268-001	Mandatory ¹
5	Four-bay SFF drive cage	725270-001	Mandatory ¹
6	SFF hot-plug drive blank	670033-001	Mandatory ¹
7	LFF non-hot-plug drive carrier**	691585-001	Mandatory ¹
8	LFF hot-plug drive blank	675039-001	Mandatory ¹
9	Two-bay LFF drive cage	725272-001	Mandatory ¹

Item	Description	Spare part number	Customer self repair (on page 6)
10	HP CS power supply cage	725278-001	Mandatory ¹
11	Integrated power supply rear cover	725276-001	Optional ²
12	PCI riser cage	725265-001	Mandatory ¹
13	Quick-release lever type rack ears*	725269-001	Mandatory ¹
14	Rack rail cable ties*	730580-001	Mandatory ¹

* Not shown

** When no drive is installed in the non-hot-plug drive carrier, it serves as a blank for a non-hot-plug drive configuration.

¹Mandatory—Parts for which customer self repair is mandatory. If you request HP to replace these parts, you will be charged for the travel and labor costs of this service.

²Optional—Parts for which customer self repair is optional. These parts are also designed for customer self repair. If, however, you require that HP replace them for you, there may or may not be additional charges, depending on the type of warranty service designated for your product.

³No—Some HP parts are not designed for customer self repair. In order to satisfy the customer warranty, HP requires that an authorized service provider replace the part. These parts are identified as "No" in the Illustrated Parts Catalog.

¹Mandatory: Obligatoire—Pièces pour lesquelles la réparation par le client est obligatoire. Si vous demandez à HP de remplacer ces pièces, les coûts de déplacement et main d'œuvre du service vous seront facturés.

²Optional: Facultatif—Pièces pour lesquelles la réparation par le client est facultative. Ces pièces sont également conçues pour permettre au client d'effectuer lui-même la réparation. Toutefois, si vous demandez à HP de remplacer ces pièces, l'intervention peut ou non vous être facturée, selon le type de garantie applicable à votre produit.

³No: Non—Certaines pièces HP ne sont pas conçues pour permettre au client d'effectuer lui-même la réparation. Pour que la garantie puisse s'appliquer, HP exige que le remplacement de la pièce soit effectué par un Mainteneur Agréé. Ces pièces sont identifiées par la mention "Non" dans le Catalogue illustré.

¹Mandatory: Obbligatorie—Parti che devono essere necessariamente riparate dal cliente. Se il cliente ne affida la riparazione ad HP, deve sostenere le spese di spedizione e di manodopera per il servizio.

²Optional: Opzionali—Parti la cui riparazione da parte del cliente è facoltativa. Si tratta comunque di componenti progettati per questo scopo. Se tuttavia il cliente ne richiede la sostituzione ad HP, potrebbe dover sostenere spese aggiuntive a seconda del tipo di garanzia previsto per il prodotto.

³No: Non CSR—Alcuni componenti HP non sono progettati per la riparazione da parte del cliente. Per rispettare la garanzia, HP richiede che queste parti siano sostituite da un centro di assistenza autorizzato. Tali parti sono identificate da un "No" nel Catalogo illustrato dei componenti.

¹Mandatory: Zwingend—Teile, die im Rahmen des Customer Self Repair Programms ersetzt werden müssen. Wenn Sie diese Teile von HP ersetzen lassen, werden Ihnen die Versand- und Arbeitskosten für diesen Service berechnet.

²Optional: Optional—Teile, für die das Customer Self Repair-Verfahren optional ist. Diese Teile sind auch für Customer Self Repair ausgelegt. Wenn Sie jedoch den Austausch dieser Teile von HP vornehmen lassen möchten, können bei diesem Service je nach den für Ihr Produkt vorgesehenen Garantiebedingungen zusätzliche Kosten anfallen.

³No: Kein—Einige Teile sind nicht für Customer Self Repair ausgelegt. Um den Garantieanspruch des Kunden zu erfüllen, muss das Teil von einem HP Servicepartner ersetzt werden. Im illustrierten Teilekatalog sind diese Teile mit „No“ bzw. „Nein“ gekennzeichnet.

¹Mandatory: Obligatorio—componentes para los que la reparación por parte del usuario es obligatoria. Si solicita a HP que realice la sustitución de estos componentes, tendrá que hacerse cargo de los gastos de desplazamiento y de mano de obra de dicho servicio.

²Optional: Opcional— componentes para los que la reparación por parte del usuario es opcional. Estos componentes también están diseñados para que puedan ser reparados por el usuario. Sin embargo, si precisa que HP realice su sustitución, puede o no conllevar costes adicionales, dependiendo del tipo de servicio de garantía correspondiente al producto.

³No: No—Algunos componentes no están diseñados para que puedan ser reparados por el usuario. Para que el usuario haga valer su garantía, HP pone como condición que un proveedor de servicios autorizado realice la sustitución de estos componentes. Dichos componentes se identifican con la palabra “No” en el catálogo ilustrado de componentes.

¹Mandatory: Verplicht—Onderdelen waarvoor Customer Self Repair verplicht is. Als u HP verzoekt deze onderdelen te vervangen, komen de reiskosten en het arbeidsloon voor uw rekening.

²Optional: Optioneel—Onderdelen waarvoor reparatie door de klant optioneel is. Ook deze onderdelen zijn ontworpen voor reparatie door de klant. Als u echter HP verzoekt deze onderdelen voor u te vervangen, kunnen daarvoor extra kosten in rekening worden gebracht, afhankelijk van het type garantieservice voor het product.

³No: Nee—Sommige HP onderdelen zijn niet ontwikkeld voor reparatie door de klant. In verband met de garantiev voorwaarden moet het onderdeel door een geautoriseerde Service Partner worden vervangen. Deze onderdelen worden in de geïllustreerde onderdelencatalogus aangemerkt met “Nee”.

¹Mandatory: Obrigatória—Peças cujo reparo feito pelo cliente é obrigatório. Se desejar que a HP substitua essas peças, serão cobradas as despesas de transporte e mão-de-obra do serviço.

²Optional: Opcional—Peças cujo reparo feito pelo cliente é opcional. Essas peças também são projetadas para o reparo feito pelo cliente. No entanto, se desejar que a HP as substitua, pode haver ou não a cobrança de taxa adicional, dependendo do tipo de serviço de garantia destinado ao produto.

³No: Nenhuma—Algumas peças da HP não são projetadas para o reparo feito pelo cliente. A fim de cumprir a garantia do cliente, a HP exige que um técnico autorizado substitua a peça. Essas peças estão identificadas com a marca “No” (Não), no catálogo de peças ilustrado.

¹Mandatory : 必須 - 顧客自己修理が必須の部品。当該部品について、もしもお客様がHPに交換作業を依頼される場合には、その修理サービスに関する交通費および人件費がお客様に請求されます。

²Optional : 任意 - 顧客自己修理が任意である部品。この部品も顧客自己修理用です。当該部品について、もしもお客様がHPに交換作業を依頼される場合には、お買い上げの製品に適用される保証サービス内容の範囲内においては、費用を負担していただくことなく保証サービスを受けることができます。

³No : 除外 - HP製品の一部の部品は、顧客自己修理用ではありません。製品の保証を継続するためには、HPまたはHP正規保守代理店による交換作業が必須となります。部品カタログには、当該部品が顧客自己修理除外品である旨が記載されています。

¹Mandatory: 强制性的 — 要求客户必须自行维修的部件。如果您请求 HP 更换这些部件，则必须为该服务支付差旅费和人工费用。

²Optional: 可选的 — 客户可以选择是否自行维修的部件。这些部件也是为客户自行维修设计的。不过，如果您要求 HP 为您更换这些部件，则根据为您的产品指定的保修服务类型，HP 可能收取或不再收取任何附加费用。

³No: 否 — 某些 HP 部件的设计并未考虑客户自行维修。为了满足客户保修的需要，HP 要求授权服务提供商更换相关部件。这些部件在部件图解目录中标记为“否”。

¹Mandatory: 強制的 — 客戶自行維修所使用的零件是強制的。如果您要求 HP 更換這些零件，HP 將會向您收取此服務所需的外出費用與勞動成本。

²Optional: 選購的 — 客戶自行維修所使用的零件是選購的。這些零件也設計用於客戶自行維修之用。不過，如果您要求 HP 為您更換，則可能需要也可能不需要負擔額外的費用，端視針對此產品指定的保固服務類型而定。

³No: 否 — 某些 HP 零件沒有消費者可自行維修的設計。為符合客戶保固，HP 需要授權的服務供應商更換零件。這些零件在圖示的零件目錄中，被標示為「否」。

¹ Mandatory: 필수 — 고객 셀프 수리가 의무 사항인 필수 부품. 사용자가 HP에 이 부품의 교체를 요청할 경우 이 서비스에 대한 출장비 및 작업비가 청구됩니다.

² Optional: 옵션 — 고객 셀프 수리가 선택 사항인 부품. 이 부품들도 고객 셀프 수리가 가능하도록 설계되었습니다. 하지만 사용자가 HP에 이 부품의 교체를 요청할 경우 사용자가 구입한 제품에 해당하는 보증 서비스 유형에 따라 추가 비용 없이 교체가 가능할 수 있습니다.

³ No: No — 고객 셀프 수리가 불가능하도록 설계된 HP 부품. 이 부품들은 고객 셀프 수리가 불가능하도록 설계되었습니다. HP는 고객 보증을 만족시키기 위해 공인 서비스 제공업체를 통해 부품을 교체하도록 하고 있습니다.

System components

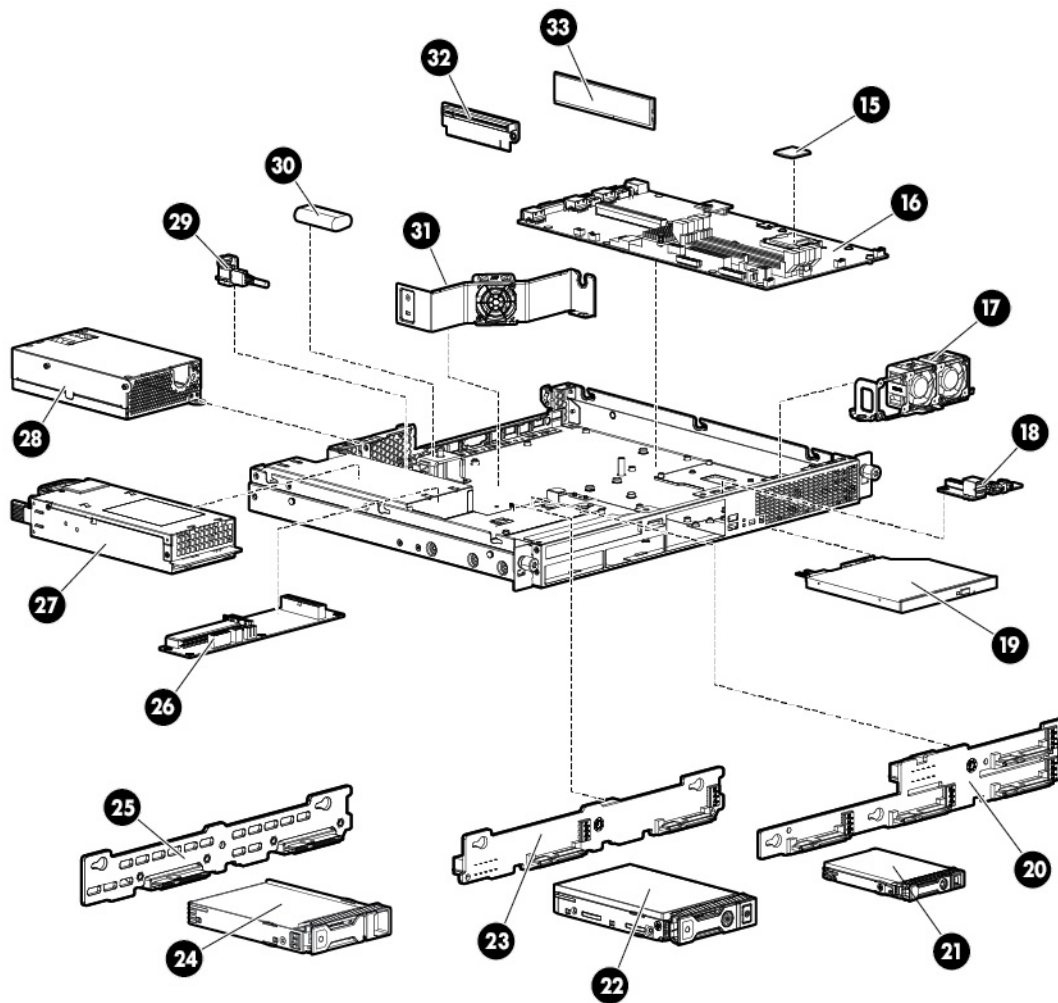

Item	Description	Spare part number	Customer self repair (on page 6)
15	Processors (include alcohol pad and thermal compound)	—	—
	a) 1.80-Ghz Intel Xeon E3-1230L v3 processor, 4C, 8 MB, 25 W*	726769-001	Optional ²
	b) 2.50-Ghz Intel Xeon E3-1265L v3 processor, 4C, 8 MB, 45 W*	725281-001	Optional ²
	c) 2.90-Ghz Intel Core i3-4130T processor, 2C, 3 MB, 35 W*	741663-001	Optional ²
	d) 3.00-Ghz Intel Pentium G3220 processor, 2C, 3 MB, 54 W*	741661-001	Optional ²
	e) 3.10-GHz Intel Pentium G3240 processor, 2C, 3 MB, 54 W	773059-001	Optional ²
	f) 3.10-GHz Intel Xeon E3-1220 v3 processor, 4C, 8 MB, 80 W*	725282-001	Optional ²
	g) 3.20-Ghz Intel Pentium G3420 processor, 2C, 3 MB, 54 W*	741664-001	Optional ²
	h) 3.30-GHz Intel Xeon E3-1230 v3 processor, 4C, 8 MB, 80 W*	725283-001	Optional ²

Item	Description	Spare part number	Customer self repair (on page 6)
	i) 3.40-GHz Intel Core i3-4130 processor, 2C, 3 MB, 54 W*	741662-001	Optional ²
	j) 3.40-GHz Intel Xeon E3-1231 v3 processor, 4C, 8 MB, 80 W	773054-001	Optional ²
	k) 3.40-GHz Intel Xeon E3-1240 v3 processor, 4C, 8 MB, 80 W*	725284-001	Optional ²
	l) 3.50-GHz Intel Core i3-4150 processor, 2C, 3 MB, 54 W	773057-001	Optional ²
	m) 3.50-GHz Intel Xeon E3-1241 v3 processor, 4C, 8 MB, 80 W	773055-001	Optional ²
	n) 3.50-GHz Intel Xeon E3-1270 v3 processor, 4C, 8 MB, 80 W*	725285-001	Optional ²
	o) 3.60-GHz Intel Xeon E3-1271 v3 processor, 4C, 8 MB, 80 W	773056-001	Optional ²
	p) 3.60-GHz Intel Xeon E3-1280 v3 processor, 4C, 8 MB, 95 W*	725286-001	Optional ²
	q) 3.70-GHz Intel Xeon E3-1281 v3 processor, 4C, 8 MB, 82 W	769515-001	Optional ²
16	System board assemblies (include alcohol pad and thermal compound)	—	—
	a) System board assembly	769743-001	Optional ²
	b) System board assembly**	725260-001	Optional ²
17	Front fan cage assembly	725263-001	Mandatory ¹
	a) Front fan cage	—	—
	b) Non-hot-plug fan modules (2)*	—	—
	c) T-15 screws (3)*	—	—
18	Front I/O module assembly	725267-001	Optional ²
19	SATA DVD-RW optical drive (9.5 mm, 0.37 in)	652297-001	Mandatory ¹
20	4 SFF hot-plug drive cage backplane	725271-001	Mandatory ¹
21	SFF hot-plug drives (6.35 cm, 2.5 in)	—	—
	SATA hard drives	—	—
	a) 500 GB 6G 7,200-rpm SC MDL hard drive	656107-001	Mandatory ¹
	b) 1 TB 6G 7,200-rpm SC MDL hard drive*	656108-001	Mandatory ¹
	SATA solid state drives	—	—
	a) 100 GB 3G MLC SC EM solid state drive*	653965-001	Mandatory ¹
	b) 100 GB 6G ME SC EM solid state drive*	692164-001	Mandatory ¹
	c) 200 GB 3G MLC SC EM solid state drive*	653966-001	Mandatory ¹
	d) 200 GB 6G ME SC EM solid state drive*	692165-001	Mandatory ¹
	e) 400 GB 3G MLC SC EM solid state drive*	653967-001	Mandatory ¹
	f) 400 GB 6G ME SC EM solid state drive*	692166-001	Mandatory ¹
	g) 800 GB 6G ME SC EM solid state drive*	692167-001	Mandatory ¹
	SAS hard drives	—	—
	a) 146 GB 6G 15,000-rpm SC ENT hard drive*	653950-001	Mandatory ¹

Item	Description	Spare part number	Customer self repair (on page 6)
	b) 300 GB 6G 10,000-rpm SC ENT hard drive*	653955-001	Mandatory ¹
	c) 300 GB 6G 15,000-rpm SC ENT hard drive*	653960-001	Mandatory ¹
	d) 450 GB 6G 10,000-rpm SC ENT hard drive*	653956-001	Mandatory ¹
	e) 500 GB 6G 7,200-rpm SC MDL hard drive*	653953-001	Mandatory ¹
	f) 600 GB 6G 10,000-rpm SC ENT hard drive*	653957-001	Mandatory ¹
	g) 900 GB 6G 10,000-rpm SC ENT hard drive*	653971-001	Mandatory ¹
	h) 1 TB 6G 7,200-rpm SC MDL hard drive*	653954-001	Mandatory ¹
	i) 1.2 TB 6G 10,000-rpm DP ENT SC hard drive*	697631-001	Mandatory ¹
	j) 1.2 TB 6G 10,000-rpm DP ENT SC hard drive*	718292-001	Mandatory ¹
22	LFF hot-plug drives (8.89 cm, 3.5 in)	—	—
	SATA hard drives	—	—
	a) 500 GB 6G 7,200-rpm SC MDL hard drive	652103-001	Mandatory ¹
	b) 1 TB 6G 7,200-rpm SC MDL hard drive*	657739-001	Mandatory ¹
	c) 2 TB 6G 7,200-rpm SC MDL hard drive*	658102-001	Mandatory ¹
	d) 3 TB 6G 7,200-rpm SC MDL hard drive*	628182-001	Mandatory ¹
	e) 4 TB 6G 7,200-rpm SC MDL hard drive*	693720-001	Mandatory ¹
	SATA solid state drives	—	—
	a) 100 GB 3G MLC SC EM solid state drive*	653968-001	Mandatory ¹
	b) 100 GB 6G ME SC EM solid state drive*	692160-001	Mandatory ¹
	c) 200 GB 3G MLC SC EM solid state drive*	653969-001	Mandatory ¹
	d) 200 GB 6G ME SC EM solid state drive*	692161-001	Mandatory ¹
	e) 400 GB 3G MLC SC EM solid state drive*	653970-001	Mandatory ¹
	f) 400 GB 6G ME SC EM solid state drive*	692162-001	Mandatory ¹
	g) 800 GB 6G ME SC EM solid state drive*	692163-001	Mandatory ¹
	SAS hard drives	—	—
	a) 1 TB 6G 7,200-rpm SC MDL hard drive*	653947-001	Mandatory ¹
	b) 2 TB 6G 7,200-rpm SC MDL hard drive*	653948-001	Mandatory ¹
	c) 3 TB 6G 7,200-rpm SC MDL hard drive*	653959-001	Mandatory ¹
	d) 4 TB 6G 7,200-rpm SC MDL hard drive*	693721-001	Mandatory ¹
23	2 LFF hot-plug drive cage backplane	725273-001	Mandatory ¹
24	LFF non-hot-plug SATA hard drives (8.89 cm, 3.5 in)	—	—
	a) 500 GB 6G 7,200-rpm MDL hard drive	659571-001	Mandatory ¹
	b) 1 TB 6G 7,200-rpm MDL hard drive*	659569-001	Mandatory ¹
	c) 2 TB 6G 7,200-rpm MDL hard drive*	659570-001	Mandatory ¹
	d) 3 TB 6G 7,200-rpm MDL hard drive*	628183-001	Mandatory ¹

Item	Description	Spare part number	Customer self repair (on page 6)
25	2 LFF non-hot-plug drive cage bracket	725275-001	Mandatory ¹
26	HP 750 W CS -48 V DC power supply enablement kit	725277-001	Mandatory ¹
	a) Power distribution board	—	—
	b) PDB tray*	—	—
	c) PSU baffle*	—	—
	d) 24-pin system board power cable*	—	—
	e) 4-pin system board power cable*	—	—
	f) 10-pin power cable for the 4 SFF hot-plug drive cage*	—	—
	g) 26-pin PDB cable*	—	—
	h) 4-pin optical drive power cable*	—	—
	i) T-15 screws (6)*	—	—
	j) T-10 screws (2)*	—	—
	Power supplies	—	—
27	HP 250 W Integrated Power Supply	751909-001	Mandatory ¹
28	HP 300 W Integrated Power Supply	718785-001	Mandatory ¹
29	HP 750 W CS -48 V DC Power Supply (94% efficiency)	639173-001	Mandatory ¹
30	Internal USB connector	677066-001	Mandatory ¹
31	FBWC capacitor pack	671353-001	Optional ²
32	Center fan assembly	725264-001	Mandatory ¹
	a) Non-hot-plug fan module with bracket	—	—
	b) Fan extension cable*	—	—
	c) T-10 screws (4)*	—	—
33	PCIe x16 low-profile, dual-slot riser board	725266-001	Mandatory ¹
34	DIMMs	—	—
	a) 2 GB, single-rank, x8, PC3L-10600E-9	664694-001	Mandatory ¹
	b) 2 GB, single-rank, x8, PCL3-12800E-11*	715279-001	Mandatory ¹
	c) 2 GB, single-rank, x8, PC3-12800E-11*	684033-001	Mandatory ¹
	d) 4 GB, dual-rank, x8, PC3L-10600E-9*	664695-001	Mandatory ¹
	e) 4 GB, dual-rank, x8, PCL3-12800E-11*	715280-001	Mandatory ¹
	f) 4 GB, dual-rank, x8, PC3-12800E-11*	684034-001	Mandatory ¹
	g) 8 GB, dual-rank, x8, PC3L-10600E-9*	664696-001	Mandatory ¹
	h) 8 GB, dual-rank, x8, PCL3-12800E-11*	715281-001	Mandatory ¹
	i) 8 GB, dual-rank, x8 ,PC3-12800E-11*	684035-001	Mandatory ¹
35	System battery*	234556-001	Optional ²
36	FBWC module	—	—
	a) 512 MB*	633540-001	Optional ²
	b) 1 GB*	633542-001	Optional ²

Item	Description	Spare part number	Customer self repair (on page 6)
	c) 2 GB*	633543-001	Optional ²
37	270-mm Mini-SAS cable*	725274-001	Mandatory ¹

* Not shown

** For use with Xeon E3-1230L v3, E3-1265L v3, E3-1220 v3, E3-1230 v3, E3-1240 v3, E3-1270 v3, and E3-1280 v3 processor systems; Core i3-4130T and i3-4130 processor systems; Pentium G3220 and G3420 processor systems.

¹Mandatory—Parts for which customer self repair is mandatory. If you request HP to replace these parts, you will be charged for the travel and labor costs of this service.

²Optional—Parts for which customer self repair is optional. These parts are also designed for customer self repair. If, however, you require that HP replace them for you, there may or may not be additional charges, depending on the type of warranty service designated for your product.

³No—Some HP parts are not designed for customer self repair. In order to satisfy the customer warranty, HP requires that an authorized service provider replace the part. These parts are identified as "No" in the Illustrated Parts Catalog.

¹Mandatory: Obligatoire—Pièces pour lesquelles la réparation par le client est obligatoire. Si vous demandez à HP de remplacer ces pièces, les coûts de déplacement et main d'œuvre du service vous seront facturés.

²Optional: Facultatif—Pièces pour lesquelles la réparation par le client est facultative. Ces pièces sont également conçues pour permettre au client d'effectuer lui-même la réparation. Toutefois, si vous demandez à HP de remplacer ces pièces, l'intervention peut ou non vous être facturée, selon le type de garantie applicable à votre produit.

³No: Non—Certaines pièces HP ne sont pas conçues pour permettre au client d'effectuer lui-même la réparation. Pour que la garantie puisse s'appliquer, HP exige que le remplacement de la pièce soit effectué par un Mainteneur Agréé. Ces pièces sont identifiées par la mention "Non" dans le Catalogue illustré.

¹Mandatory: Obbligatorie—Parti che devono essere necessariamente riparate dal cliente. Se il cliente ne affida la riparazione ad HP, deve sostenere le spese di spedizione e di manodopera per il servizio.

²Optional: Opzionali—Parti la cui riparazione da parte del cliente è facoltativa. Si tratta comunque di componenti progettati per questo scopo. Se tuttavia il cliente ne richiede la sostituzione ad HP, potrebbe dover sostenere spese addizionali a seconda del tipo di garanzia previsto per il prodotto.

³No: Non CSR—Alcuni componenti HP non sono progettati per la riparazione da parte del cliente. Per rispettare la garanzia, HP richiede che queste parti siano sostituite da un centro di assistenza autorizzato. Tali parti sono identificate da un "No" nel Catalogo illustrato dei componenti.

¹Mandatory: Zwingend—Teile, die im Rahmen des Customer Self Repair Programms ersetzt werden müssen. Wenn Sie diese Teile von HP ersetzen lassen, werden Ihnen die Versand- und Arbeitskosten für diesen Service berechnet.

²Optional: Optional—Teile, für die das Customer Self Repair-Verfahren optional ist. Diese Teile sind auch für Customer Self Repair ausgelegt. Wenn Sie jedoch den Austausch dieser Teile von HP vornehmen lassen möchten, können bei diesem Service je nach den für Ihr Produkt vorgesehenen Garantiebedingungen zusätzliche Kosten anfallen.

³No: Kein—Einige Teile sind nicht für Customer Self Repair ausgelegt. Um den Garantieanspruch des Kunden zu erfüllen, muss das Teil von einem HP Servicepartner ersetzt werden. Im illustrierten Teilekatalog sind diese Teile mit „No“ bzw. „Nein“ gekennzeichnet.

¹Mandatory: Obligatorio—componentes para los que la reparación por parte del usuario es obligatoria. Si solicita a HP que realice la sustitución de estos componentes, tendrá que hacerse cargo de los gastos de desplazamiento y de mano de obra de dicho servicio.

²Optional: Opcional— componentes para los que la reparación por parte del usuario es opcional. Estos componentes también están diseñados para que puedan ser reparados por el usuario. Sin embargo, si precisa que HP realice su sustitución, puede o no conllevar costes adicionales, dependiendo del tipo de servicio de garantía correspondiente al producto.

³No: No—Algunos componentes no están diseñados para que puedan ser reparados por el usuario. Para que el usuario haga valer su garantía, HP pone como condición que un proveedor de servicios autorizado realice la sustitución de estos componentes. Dichos componentes se identifican con la palabra "No" en el catálogo ilustrado de componentes.

¹Mandatory: Verplicht—Onderdelen waarvoor Customer Self Repair verplicht is. Als u HP verzoekt deze onderdelen te vervangen, komen de reiskosten en het arbeidsloon voor uw rekening.

²Optional: Optioneel—Onderdelen waarvoor reparatie door de klant optioneel is. Ook deze onderdelen zijn ontworpen voor reparatie door de klant. Als u echter HP verzoekt deze onderdelen voor u te vervangen, kunnen daarvoor extra kosten in rekening worden gebracht, afhankelijk van het type garanteservice voor het product.

³No: Nee—Sommige HP onderdelen zijn niet ontwikkeld voor reparatie door de klant. In verband met de garantievoorzwaarden moet het onderdeel door een geautoriseerde Service Partner worden vervangen. Deze onderdelen worden in de geïllustreerde onderdelencatalogus aangemerkt met "Nee".

¹Mandatory: Obrigatória—Peças cujo reparo feito pelo cliente é obrigatório. Se desejar que a HP substitua essas peças, serão cobradas as despesas de transporte e mão-de-obra do serviço.

²Optional: Opcional—Peças cujo reparo feito pelo cliente é opcional. Essas peças também são projetadas para o reparo feito pelo cliente. No entanto, se desejar que a HP as substitua, pode haver ou não a cobrança de taxa adicional, dependendo do tipo de serviço de garantia destinado ao produto.

³No: Nenhuma—Algumas peças da HP não são projetadas para o reparo feito pelo cliente. A fim de cumprir a garantia do cliente, a HP exige que um técnico autorizado substitua a peça. Essas peças estão identificadas com a marca "No" (Não), no catálogo de peças ilustrado.

¹Mandatory : 必須 - 顧客自己修理が必須の部品。当該部品について、もしもお客様がHPに交換作業を依頼される場合には、その修理サービスに関する交通費および人件費がお客様に請求されます。

²Optional : 任意 - 顧客自己修理が任意である部品。この部品も顧客自己修理用です。当該部品について、もしもお客様がHPに交換作業を依頼される場合には、お買上げの製品に適用される保証サービス内容の範囲内においては、費用を負担していただくことなく保証サービスを受けることができます。

³No : 除外 - HP製品の一部の部品は、顧客自己修理用ではありません。製品の保証を継続するためには、HPまたはHP正規保守代理店による交換作業が必須となります。部品カタログには、当該部品が顧客自己修理除外品である旨が記載されています。

¹Mandatory: 强制性的 — 要求客户必须自行维修的部件。如果您请求 HP 更换这些部件，则必须为该服务支付差旅费和人工费用。

²Optional: 可选的 — 客户可以选择是否自行维修的部件。这些部件也是为客户自行维修设计的。不过，如果您要求 HP 为您更换这些部件，则根据为您的产品指定的保修服务类型，HP 可能收取或不再收取任何附加费用。

³No: 否 — 某些 HP 部件的设计并未考虑客户自行维修。为了满足客户保修的需要，HP 要求授权服务提供商更换相关部件。这些部件在部件图解目录中标记为“否”。

¹Mandatory: 強制的 — 客戶自行維修所使用的零件是強制的。如果您要求 HP 更換這些零件，HP 將會向您收取此服務所需的外出費用與勞動成本。

²Optional: 選購的 — 客戶自行維修所使用的零件是選購的。這些零件也設計用於客戶自行維修之用。不過，如果您要求 HP 為您更換，則可能需要也可能不需要負擔額外的費用，端視針對此產品指定的保固服務類型而定。

³No: 否 — 某些 HP 零件沒有消費者可自行維修的設計。為符合客戶保固，HP 需要授權的服務供應商更換零件。這些零件在圖示的零件目錄中，被標示為「否」。

¹ Mandatory: 필수 — 고객 셀프 수리가 의무 사항인 필수 부품. 사용자가 HP에 이 부품의 교체를 요청할 경우 이 서비스에 대한 출장비 및 작업비가 청구됩니다.

² Optional: 옵션 — 고객 셀프 수리가 선택 사항인 부품. 이 부품들도 고객 셀프 수리가 가능하도록 설계되었습니다. 하지만 사용자가 HP에 이 부품의 교체를 요청할 경우 사용자가 구입한 제품에 해당하는 보증 서비스 유형에 따라 추가 비용 없이 교체가 가능할 수 있습니다.

³ No: No — 고객 셀프 수리가 불가능하도록 설계된 HP 부품. 이 부품들은 고객 셀프 수리가 불가능하도록 설계되었습니다. HP는 고객 보증을 만족시키기 위해 공인 서비스 제공업체를 통해 부품을 교체하도록 하고 있습니다.

Removal and replacement procedures

Required tools

You need the following items for some procedures:

- T-10/T-15 Torx screwdriver
- T-25 Torx screwdriver (for screws located inside the front panel quick-release levers)
- Flathead screwdriver
- HP Insight Diagnostics (on page [72](#))

Safety considerations

Before performing service procedures, review all the safety information.

Preventing electrostatic discharge

To prevent damaging the system, be aware of the precautions you need to follow when setting up the system or handling parts. A discharge of static electricity from a finger or other conductor may damage system boards or other static-sensitive devices. This type of damage may reduce the life expectancy of the device.

To prevent electrostatic damage:

- Avoid hand contact by transporting and storing products in static-safe containers.
- Keep electrostatic-sensitive parts in their containers until they arrive at static-free workstations.
- Place parts on a grounded surface before removing them from their containers.
- Avoid touching pins, leads, or circuitry.
- Always be properly grounded when touching a static-sensitive component or assembly.

Symbols on equipment

The following symbols may be placed on equipment to indicate the presence of potentially hazardous conditions.

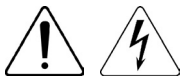

This symbol indicates the presence of hazardous energy circuits or electric shock hazards. Refer all servicing to qualified personnel.

WARNING: To reduce the risk of injury from electric shock hazards, do not open this enclosure. Refer all maintenance, upgrades, and servicing to qualified personnel.



This symbol indicates the presence of electric shock hazards. The area contains no user or field serviceable parts. Do not open for any reason.

WARNING: To reduce the risk of injury from electric shock hazards, do not open this enclosure.



This symbol on an RJ-45 receptacle indicates a network interface connection.

WARNING: To reduce the risk of electric shock, fire, or damage to the equipment, do not plug telephone or telecommunications connectors into this receptacle.

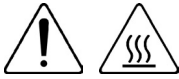

This symbol indicates the presence of a hot surface or hot component. If this surface is contacted, the potential for injury exists.

WARNING: To reduce the risk of injury from a hot component, allow the surface to cool before touching.

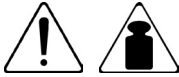

This symbol indicates that the component exceeds the recommended weight for one individual to handle safely.

WARNING: To reduce the risk of personal injury or damage to the equipment, observe local occupational health and safety requirements and guidelines for manual material handling.



These symbols, on power supplies or systems, indicate that the equipment is supplied by multiple sources of power.

WARNING: To reduce the risk of injury from electric shock, remove all power cords to completely disconnect power from the system.

Server warnings and cautions



WARNING: This server is very heavy. To reduce the risk of personal injury or damage to the equipment:

- Observe local occupational health and safety requirements and guidelines for manual material handling.
- Get help to lift and stabilize the product during installation or removal, especially when the product is not fastened to the rails. HP recommends that a minimum of two people are required for all rack server installations. A third person may be required to help align the server if the server is installed higher than chest level.
- Use caution when installing the server in or removing the server from the rack; it is unstable when not fastened to the rails.



WARNING: To reduce the risk of personal injury from hot surfaces, allow the drives and the internal system components to cool before touching them.



WARNING: To reduce the risk of personal injury, electric shock, or damage to the equipment, remove the power cord to remove power from the server. The front panel Power On/Standby button does not completely shut off system power. Portions of the power supply and some internal circuitry remain active until AC power is removed.







CAUTION: Protect the server from power fluctuations and temporary interruptions with a regulating uninterruptible power supply. This device protects the hardware from damage caused by power surges and voltage spikes and keeps the system in operation during a power failure.



CAUTION: Do not operate the server for long periods with the access panel open or removed. Operating the server in this manner results in improper airflow and improper cooling that can lead to thermal damage.

Rack warnings

-
-  **WARNING:** To reduce the risk of personal injury or damage to the equipment, be sure that:
- The leveling jacks are extended to the floor.
 - The full weight of the rack rests on the leveling jacks.
 - The stabilizing feet are attached to the rack if it is a single-rack installation.
 - The racks are coupled together in multiple-rack installations.
 - Only one component is extended at a time. A rack may become unstable if more than one component is extended for any reason.
-
-  **WARNING:** To reduce the risk of personal injury or equipment damage when unloading a rack:
- At least two people are needed to safely unload the rack from the pallet. An empty 42U rack can weigh as much as 115 kg (253 lb), can stand more than 2.1 m (7 ft) tall, and might become unstable when being moved on its casters.
 - Never stand in front of the rack when it is rolling down the ramp from the pallet. Always handle the rack from both sides.
-
-  **WARNING:** To reduce the risk of personal injury or damage to the equipment, adequately stabilize the rack before extending a component outside the rack. Extend only one component at a time. A rack may become unstable if more than one component is extended.
-
-  **WARNING:** When installing a server in a telco rack, be sure that the rack frame is adequately secured at the top and bottom to the building structure.
-

Preparation procedures

To access some components and perform certain service procedures, you must perform one or more of the following procedures:

- Access the product front panel ("[Remove the security bezel \(optional\)](#)" on page 28).
- Power down the server (on page 28).

If you must remove a server from a rack or a non-hot-plug component from a server, power down the server.
- Extend the server from the rack (on page 29).

If you are performing service procedures in an HP, Compaq branded, Telco, or third-party rack cabinet, you can use the locking feature of the rack rails to support the server and gain access to internal components.

For more information about Telco rack solutions, see the RackSolutions website (<http://www.racksolutions.com/hp>).
- Access the product rear panel.
- Remove the server from the rack (on page 30).

If the rack environment, cabling configuration, or the server location in the rack creates awkward conditions, remove the server from the rack.

Remove the security bezel (optional)

To access the front panel components, unlock and then remove the security bezel. The security bezel is only supported in servers that have the quick-release lever type rack ear option (PN 725269-001) installed.

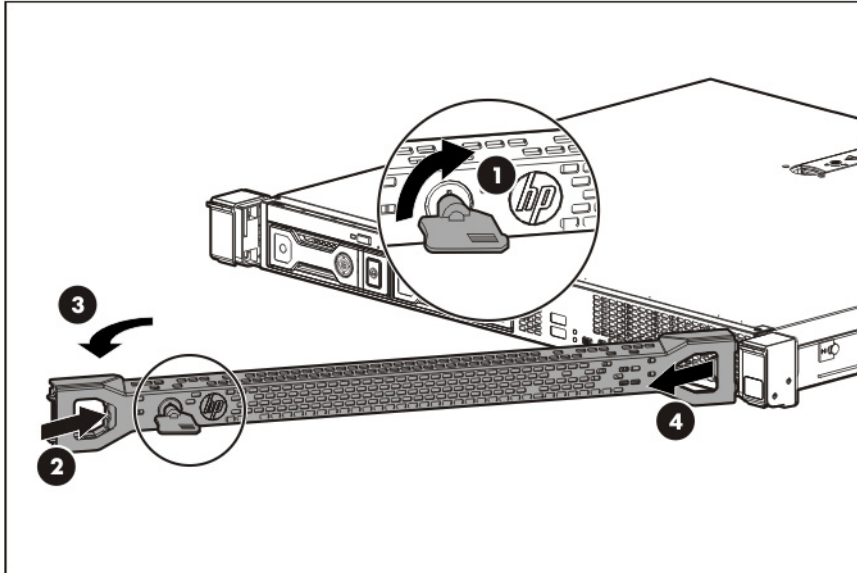

Power down the server

Before powering down the server for any upgrade or maintenance procedures, perform a backup of critical server data and programs.



WARNING: To reduce the risk of personal injury, electric shock, or damage to the equipment, remove the power cord to remove power from the server. The front panel Power On/Standby button does not completely shut off system power. Portions of the power supply and some internal circuitry remain active until AC power is removed.



IMPORTANT: When the server is in standby mode, auxiliary power is still being provided to the system.

To power down the server, use one of the following methods:

- Press and release the Power On/Standby button.
This method initiates a controlled shutdown of applications and the OS before the server enters standby mode.
- Press and hold the Power On/Standby button for more than 4 seconds to force the server to enter standby mode.
This method forces the server to enter standby mode without properly exiting applications and the OS. If an application stops responding, you can use this method to force a shutdown.
- Use a virtual power button selection through iLO 4.
This method initiates a controlled remote shutdown of applications and the OS before the server enters standby mode.

Before proceeding, verify the server is in standby mode by observing that the system power LED is amber.

Extend the server from the rack



IMPORTANT: The requirement of extending or removing the server from the rack when performing installation and maintenance procedures depends on the rail system used:

- If using a ball-bearing rail system, you can perform most installations and maintenance by simply extending the server from the rack.
- If using a friction rail system, to perform installations or maintenance that requires access panel removal, remove the server from the rack.

1. Power down the server (on page 28).
2. Release the peripheral cables and the power cord from the rack rail cable ties.

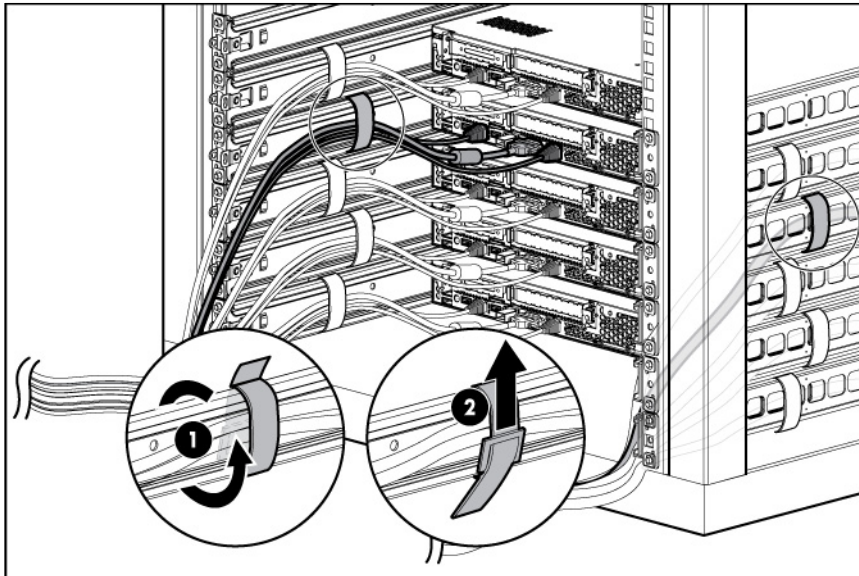

3. Remove the power from the server:
 - a. Disconnect the power cord from the power source.
 - b. Disconnect the power cord from the server.
4. Disconnect all peripheral cables from the server.



WARNING: To reduce the risk of personal injury or equipment damage, be sure that the rack is adequately stabilized before extending a component from the rack.

5. Do one of the following:
 - If the server is using a thumbscrew type rack ear, loosen the thumbscrews.
 - If the server is using a quick-release lever type rack ear, use a T-25 Torx screwdriver to loosen the screws located inside the lever housing.
6. Extend the server on the rack rails until the server rail-release latches engage.



WARNING: To reduce the risk of personal injury, be careful when pressing the server rail-release latches and sliding the server into the rack. The sliding rails could pinch your fingers.

7. After performing the installation or maintenance procedure, press the rack rail-release latches, and then slide the server into the rack. For more information, see the documentation that ships with the rack-mounting option.
8. Connect the peripheral devices to the server.

9. Connect the power cord to the server.
10. Connect the power cord to the power source.
11. Install the rack rail cable ties.

Remove the server from the rack



WARNING: This server is very heavy. To reduce the risk of personal injury or damage to the equipment:

- Observe local occupational health and safety requirements and guidelines for manual material handling.
- Get help to lift and stabilize the product during installation or removal, especially when the product is not fastened to the rails. HP recommends that a minimum of two people are required for all rack server installations. A third person may be required to help align the server if the server is installed higher than chest level.
- Use caution when installing the server in or removing the server from the rack; it is unstable when not fastened to the rails.



IMPORTANT: The requirement of extending or removing the server from the rack when performing installation and maintenance procedures depends on the rail system used:

- If using a ball-bearing rail system, you can perform most installations and maintenance by simply extending the server from the rack.
- If using a friction rail system, to perform installations or maintenance that requires access panel removal, remove the server from the rack.

1. Power down the server (on page [28](#)).
2. Extend the server from the rack (on page [29](#)).
3. Remove the server from the rack. For detailed information, see the documentation that ships with the rack mounting option.
4. Place the server on a sturdy, level surface.

Rack mount ears

To remove the component:

1. Extend the server from the rack (on page [29](#)).
2. Remove the rack mount ears:

- Thumbscrew type rack ears

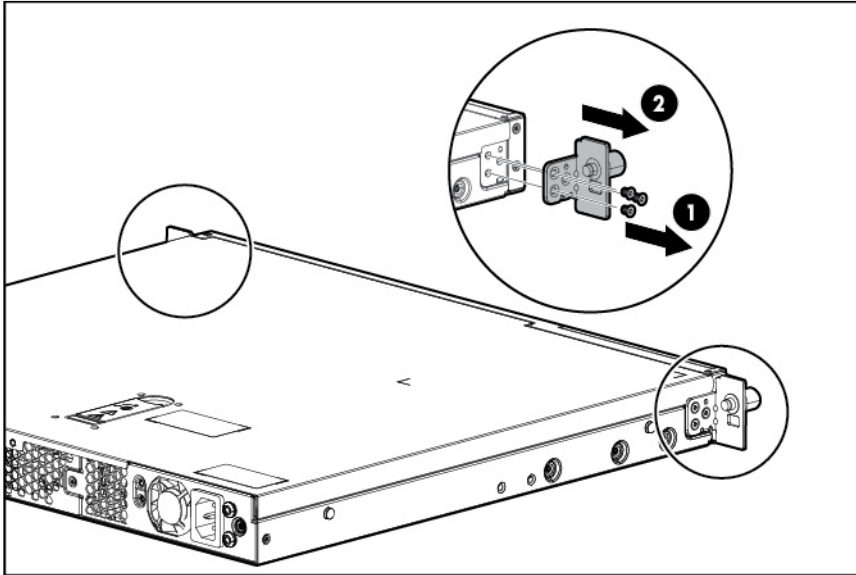

- Quick-release lever type rack ears

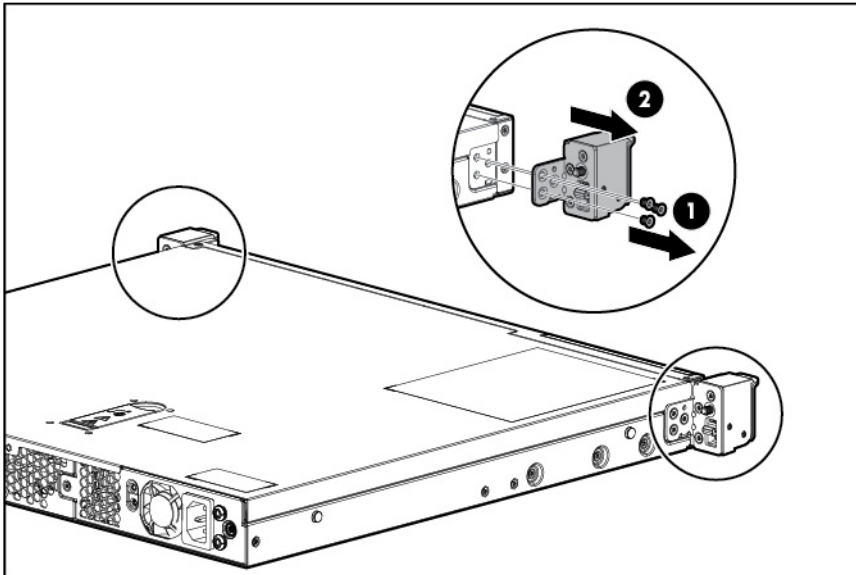

To replace the component, reverse the removal procedure.

Hot-plug drive blank



CAUTION: To prevent improper cooling and thermal damage, do not operate the server unless all bays are populated with either a component or a blank.

Remove the drive blank.

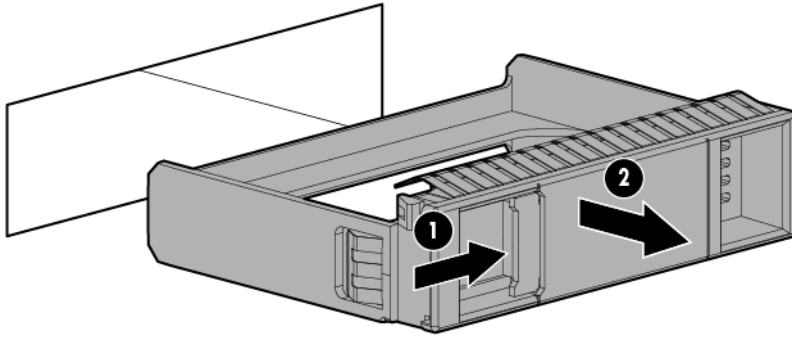

To replace the LFF drive blank, slide the component into the bay until it clicks.

To replace the SFF drive blank, while pressing the release latch, slide the component into the bay until it is fully seated.

Hot-plug drive



CAUTION: To prevent improper cooling and thermal damage, do not operate the server unless all bays are populated with either a component or a blank.

To remove the component:

1. Back up all server data on the drive.
2. Determine the status of the drive from the drive LED definitions ("[Hot-plug drive LED definitions](#)" on page 80).
3. Remove the drive.

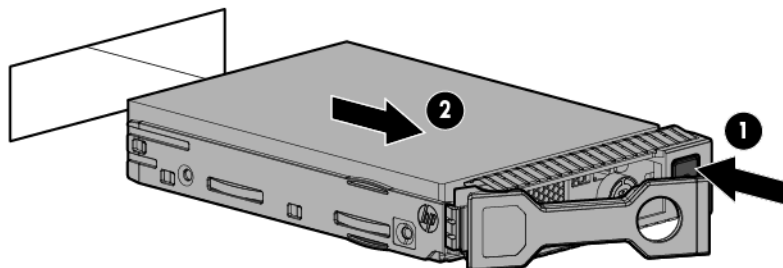

To replace the component, reverse the removal procedure.

Rack rail cable ties

To remove the component:

1. Power down the server (on page 28).

2. Release the peripheral cables and the power cord from the rack rail cable ties.

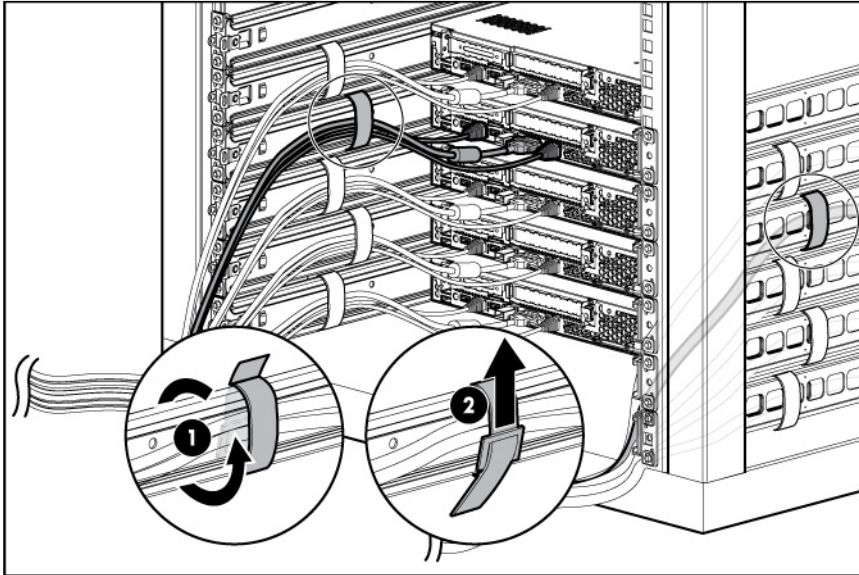

To replace the component, reverse the removal procedure.

HP CS power supply

To remove the component:

1. Power down the server (on page 28).
2. Remove the power from the server:
 - a. Disconnect the power cord from the power source.
 - b. Disconnect the power cord from the server.
3. Access the rear panel.



WARNING: To reduce the risk of personal injury from hot surfaces, allow the power supply or power supply blank to cool before touching it.

4. Remove the power supply.

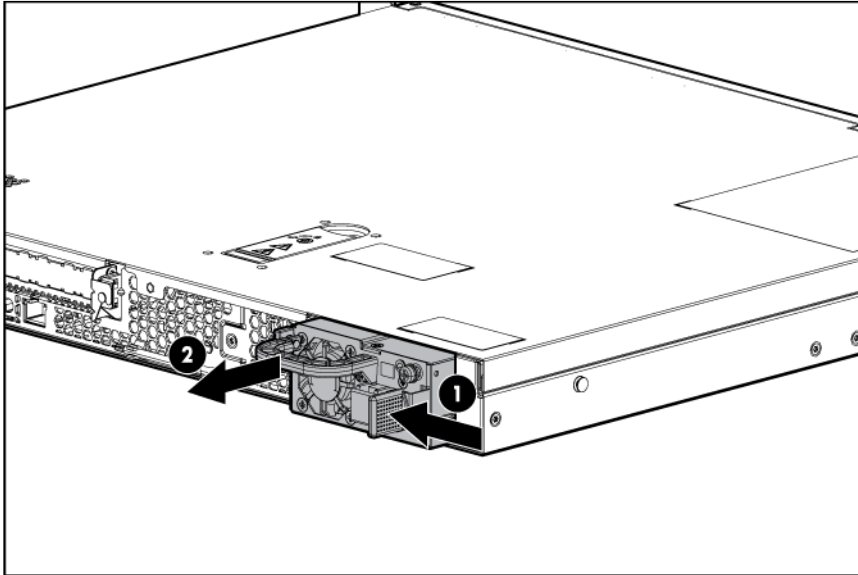

To replace the component, reverse the removal procedure.

Non-hot-plug drive carrier

CAUTION: To prevent improper cooling and thermal damage, do not operate the server unless all bays are populated with either a component or a blank.

To remove the component:

1. Power down the server (on page 28).
2. Remove the power from the server:
 - a. Disconnect the power cord from the power source.
 - b. Disconnect the power cord from the server.
3. Remove the drive carrier.

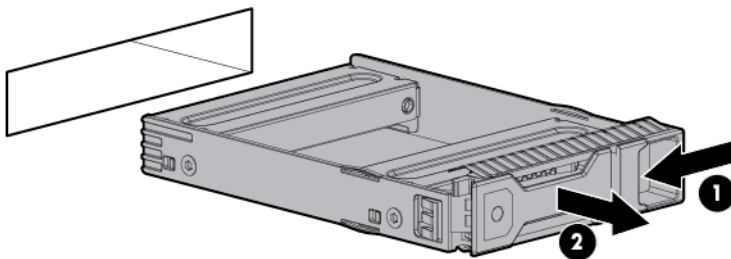

To replace the component, slide the component into the bay until it clicks.

Non-hot-plug drive

-
- ⚠ CAUTION:** To prevent improper cooling and thermal damage, do not operate the server unless all bays are populated with either a component or a blank.
-

To remove the component:

1. Back up all server data on the drive.
2. Power down the server (on page 28).
3. Remove the power from the server:
 - a. Disconnect the power cord from the power source.
 - b. Disconnect the power cord from the server.
4. Remove the drive.

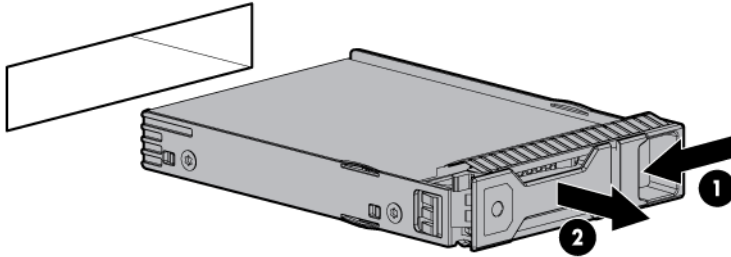

5. Remove the drive from the carrier.

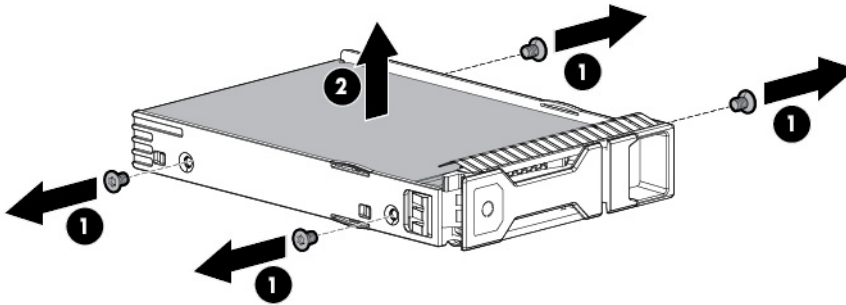

To replace the component, reverse the removal procedure.

Access panel

To remove the component:

-
- ⚠ WARNING:** To reduce the risk of personal injury from hot surfaces, allow the drives and the internal system components to cool before touching them.
-
- ⚠ CAUTION:** Do not operate the server for long periods with the access panel open or removed. Operating the server in this manner results in improper airflow and improper cooling that can lead to thermal damage.
-

1. Power down the server (on page 28).

2. Remove the power from the server:
 - a. Disconnect the power cord from the power source.
 - b. Disconnect the power cord from the server.
3. Do one of the following:
 - o Extend the server from the rack (on page 29).
 - o Remove the server from the rack (on page 30).
4. Open the access panel latch, slide the access panel to the rear of the chassis, and then remove the access panel.

If the access panel latch is locked, use a T-15 Torx screwdriver to unlock the latch.

To replace the component, reverse the removal procedure.

Air baffle

To remove the component:

CAUTION: For proper cooling, do not operate the server without the access panel, baffles, expansion slot covers, or blanks installed. If the server supports hot-plug components, minimize the amount of time the access panel is open.

1. Power down the server (on page 28).
2. Remove the power from the server:
 - a. Disconnect the power cord from the power source.
 - b. Disconnect the power cord from the server.
3. Do one of the following:
 - o Extend the server from the rack (on page 29).
 - o Remove the server from the rack (on page 30).
4. Remove the access panel ("Access panel" on page 35).
5. Remove the air baffle.

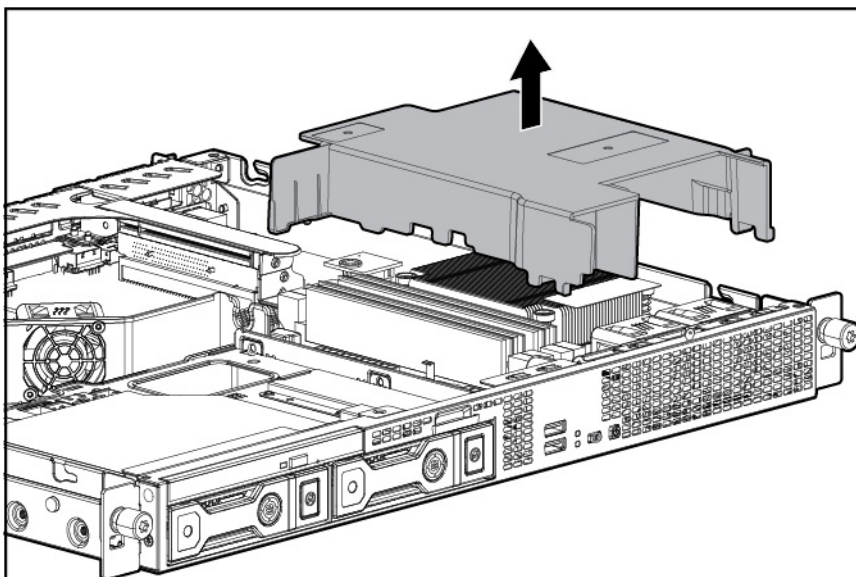

To replace the component, reverse the removal procedure.

Optical drive

△ CAUTION: To prevent improper cooling and thermal damage, do not operate the server unless all bays are populated with either a component or a blank.

To remove the component:

1. Power down the server (on page 28).
2. Remove the power from the server:
 - a. Disconnect the power cord from the power source.
 - b. Disconnect the power cord from the server.
3. Do one of the following:
 - Extend the server from the rack (on page 29).
 - Remove the server from the rack (on page 30).
4. Remove the access panel ("Access panel" on page 35).
5. Disconnect the optical drive cable from the drive.

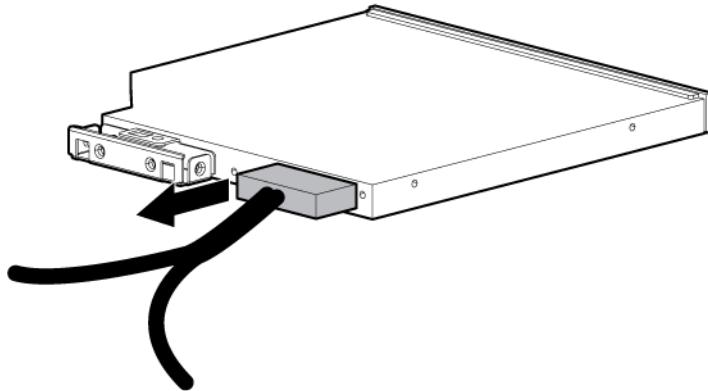

6. Remove the optical drive:

- Two-bay LFF drive model

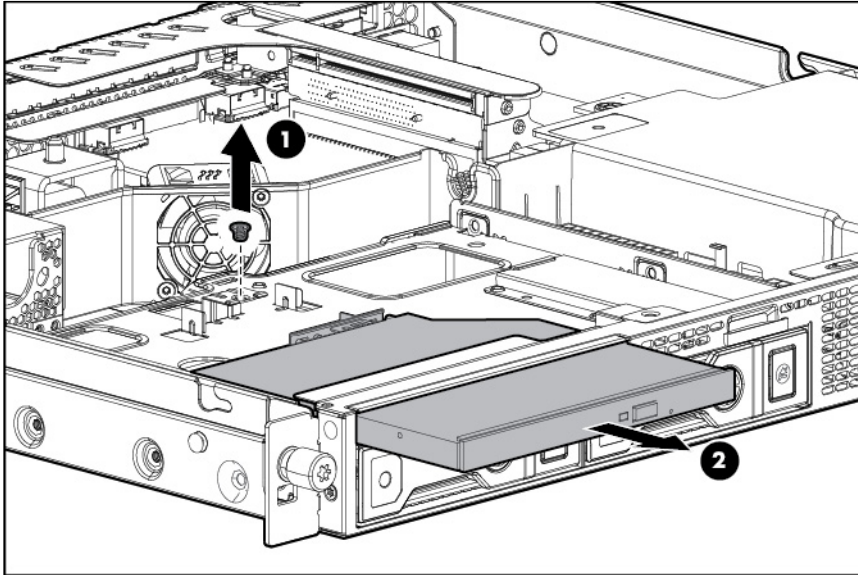

- Four-bay SFF drive model

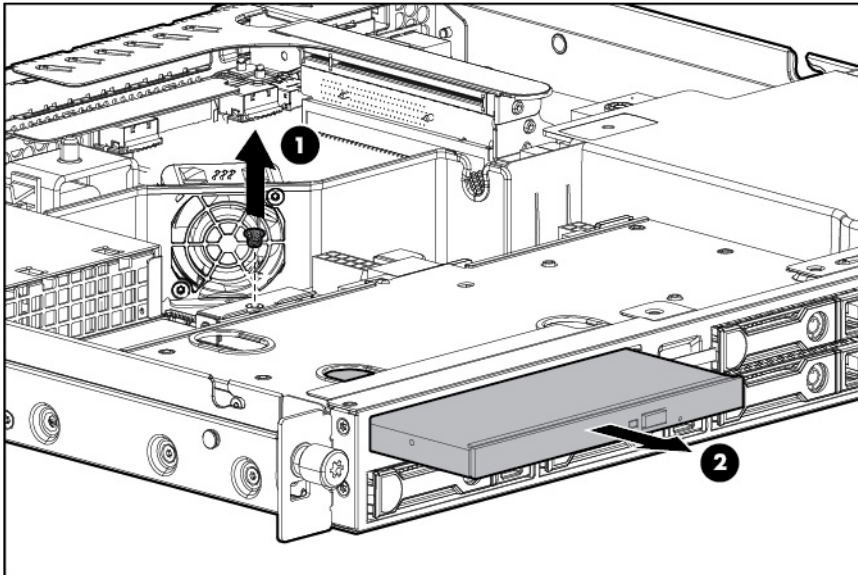

To replace the component, reverse the removal procedure.

Mini-SAS cable

To remove the component:

1. Power down the server (on page 28).
2. Remove the power from the server:
 - a. Disconnect the power cord from the power source.
 - b. Disconnect the power cord from the server.
3. Do one of the following:
 - Extend the server from the rack (on page 29).

- Remove the server from the rack (on page 30).
- 4. Remove the access panel ("Access panel" on page 35).
- 5. Do one of the following:
 - Disconnect the Mini-SAS cable from the system board, and then disconnect the cable from the drive cage.

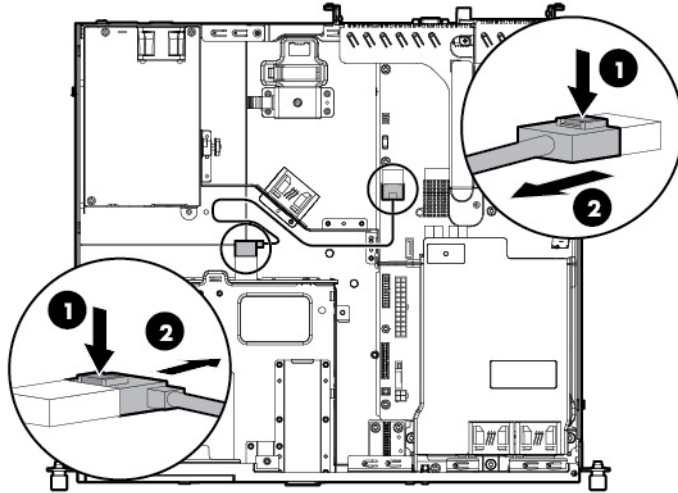

- Disconnect the Mini-SAS cable from the expansion board, and then disconnect the cable from the drive cage.

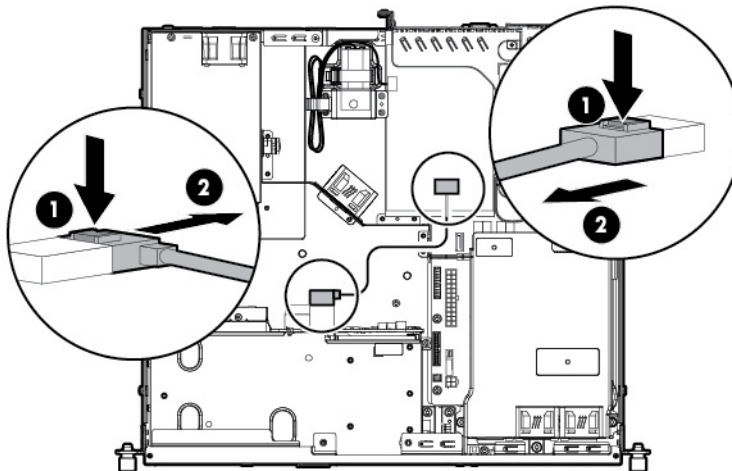

To replace the component, reverse the removal procedure.

Drive cage assembly

To remove the component:

1. Power down the server (on page 28).

2. Remove the power from the server:
 - a. Disconnect the power cord from the power source.
 - b. Disconnect the power cord from the server.
3. Remove all drives ("[Hot-plug drive](#)" on page 32, "[Non-hot-plug drive](#)" on page 34).
4. Remove the server from the rack (on page 30).
5. If the server is installed in a friction rail system, remove the friction rails from the chassis. For more information, see the documentation that ships with the rail system.
6. Remove the access panel ("[Access panel](#)" on page 35).
7. Do one of the following:
 - o Remove the optical drive ("[Optical drive](#)" on page 37).
 - o Remove the optical drive blank. Retain the blank for future use.
8. If an HP CS power supply is installed, remove the power supply distribution board ("[HP 750 W CS -48 V DC power supply enablement kit](#)" on page 62).
9. If you are replacing the drive cage with a new one, remove the serial number/iLO information pull tab from the front panel. Retain this pull tab for installation in the new drive cage.
10. Disconnect all cables from the drive cage.
11. Remove the drive cage assembly:
 - o Two-bay LFF drive model

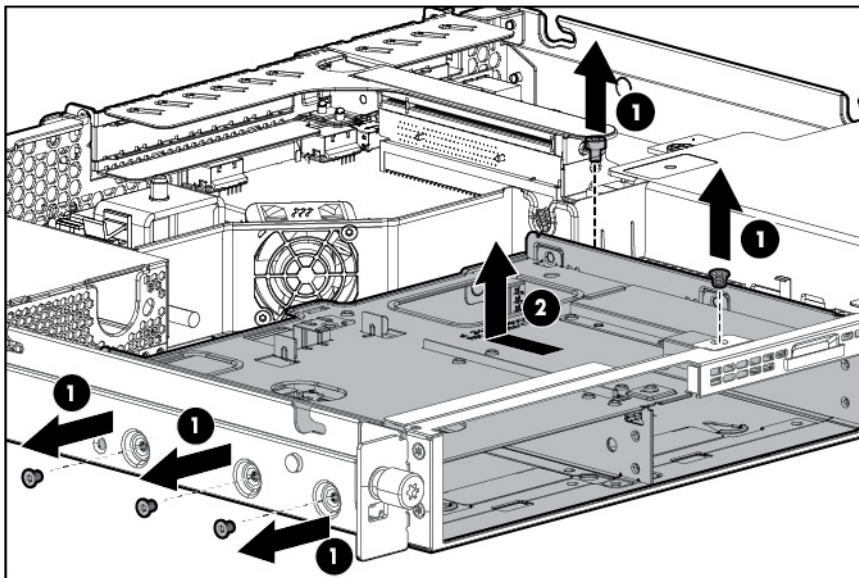

- Four-bay SFF drive model

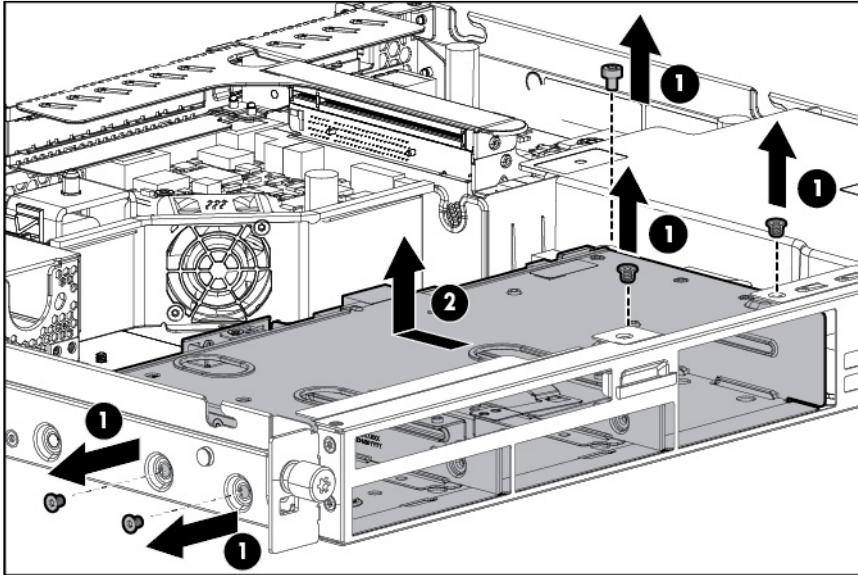

12. Do one of the following:

- Remove the drive cage backplane.
- Remove the drive cage bracket ("[Non-hot-plug drive cage bracket](#)" on page 42).

If you are replacing the drive cage with a new one, install the serial number/iLO information pull tab removed in step 9 on the new drive cage before installing it in the chassis.

To replace the component, reverse the removal procedure.

Hot-plug drive cage backplane

To remove the component:

1. Power down the server (on page 28).
2. Remove the power from the server:
 - a. Disconnect the power cord from the power source.
 - b. Disconnect the power cord from the server.
3. Remove all drives ("[Hot-plug drive](#)" on page 32, "[Non-hot-plug drive](#)" on page 34).
4. Remove the server from the rack (on page 30).
5. Remove the access panel ("[Access panel](#)" on page 35).
6. If you are removing the two-bay LFF drive backplane:
 - a. Remove the drive cage assembly.

6. Remove the drive cage bracket.

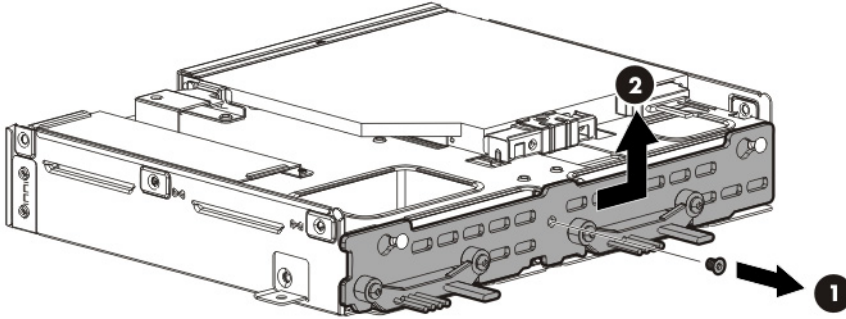

To replace the component, reverse the removal procedure.

Front I/O module assembly

To remove the component:

1. Power down the server (on page 28).
2. Remove the power from the server:
 - a. Disconnect the power cord from the power source.
 - b. Disconnect the power cord from the server.
3. Remove the access panel ("Access panel" on page 35).
4. Remove the air baffle ("Air baffle" on page 36).
5. Disconnect the front I/O module cable from the system board.
6. Remove the front I/O board.

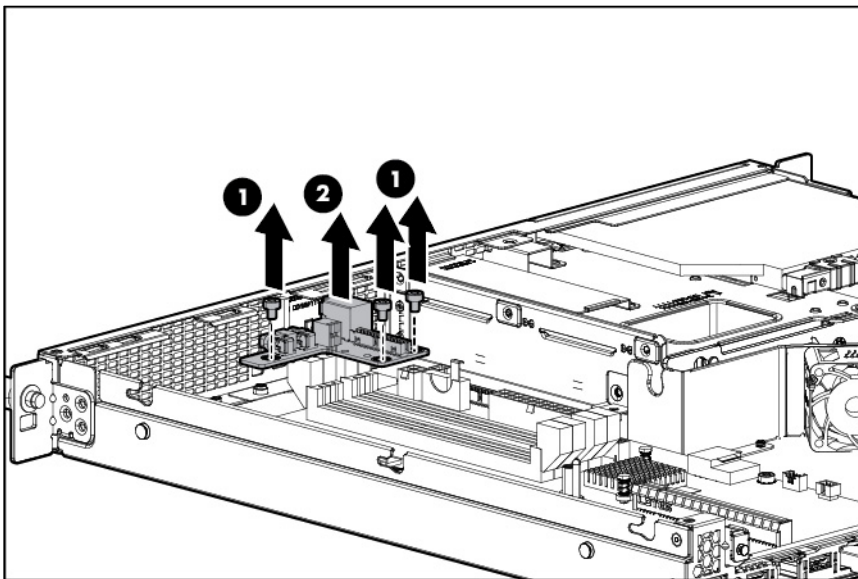

To replace the component, reverse the removal procedure.

Front fan cage assembly

CAUTION: To prevent improper cooling and thermal damage, do not operate the server unless all bays are populated with either a component or a blank.

To remove the component:

1. Power down the server (on page 28).
2. Remove the power from the server:
 - a. Disconnect the power cord from the power source.
 - b. Disconnect the power cord from the server.
3. Do one of the following:
 - o Extend the server from the rack (on page 29).
 - o Remove the server from the rack (on page 30).
4. Remove the access panel ("Access panel" on page 35).
5. Remove the air baffle ("Air baffle" on page 36).
6. Disconnect the fan cables.
7. Remove the fan cage.

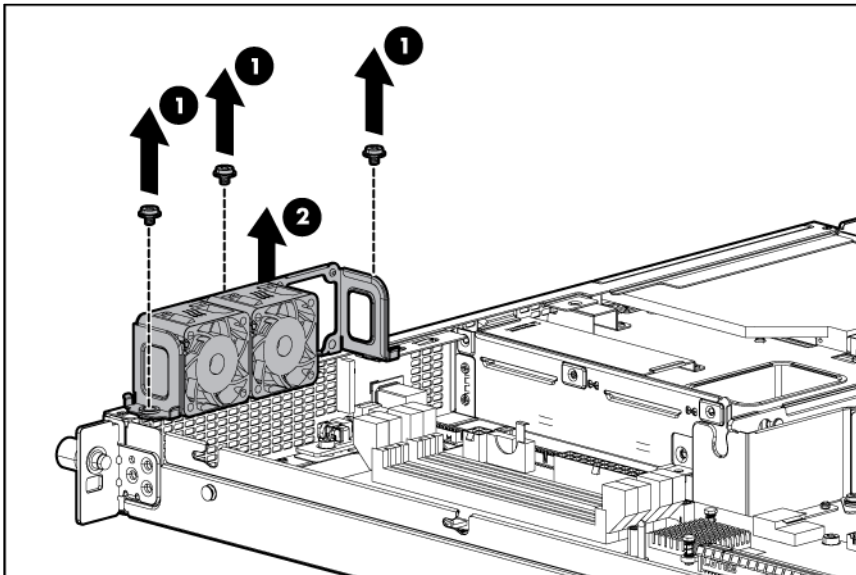

To replace the component, reverse the removal procedure.

DIMMs

To remove the component:

1. Power down the server (on page 28).
2. Remove the power from the server:
 - a. Disconnect the power cord from the power source.
 - b. Disconnect the power cord from the server.
3. Do one of the following:
 - o Extend the server from the rack (on page 29).
 - o Remove the server from the rack (on page 30).

4. Remove the access panel ("Access panel" on page 35).
5. Remove the air baffle ("Air baffle" on page 36).
6. Open the DIMM slot latches.
7. Remove the DIMM.

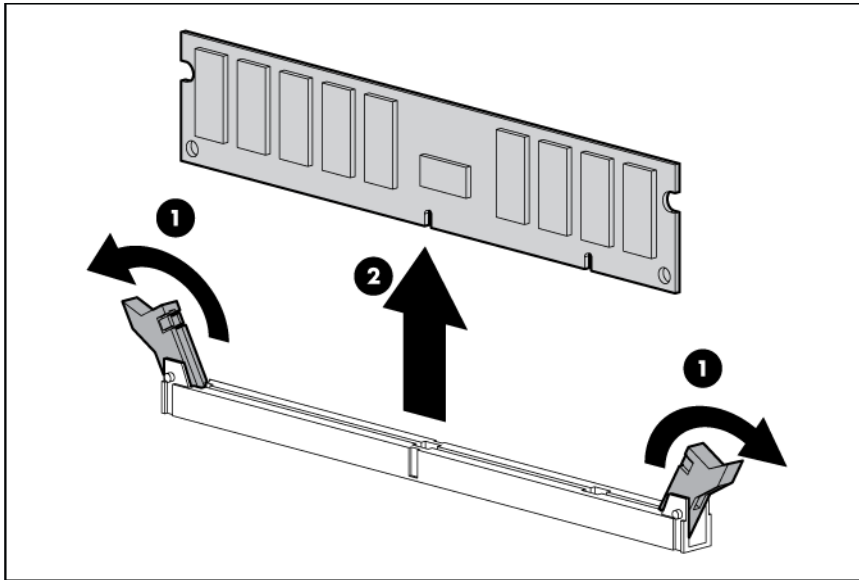

To replace the component, reverse the removal procedure.

Heatsink

To remove the component:

1. Power down the server (on page 28).
2. Remove the power from the server:
 - a. Disconnect the power cord from the power source.
 - b. Disconnect the power cord from the server.
3. Do one of the following:
 - o Extend the server from the rack (on page 29).
 - o Remove the server from the rack (on page 30).
4. Remove the access panel ("Access panel" on page 35).
5. Remove the air baffle ("Air baffle" on page 36).



WARNING: To reduce the risk of personal injury from hot surfaces, allow the heatsink to cool before touching it.



CAUTION: Heatsink retaining screws should be tightened or loosened in diagonally opposite pairs (in an "X" pattern). Do not overtighten the screws as this can damage the board, connectors, or screws. Use the wrench supplied with the system to reduce the possibility of overtightening the screws.

6. Remove the heatsink:
 - a. Loosen one pair of diagonally opposite screws halfway, and then loosen the other pair of screws.

- b. Completely loosen all screws in the same sequence.
- c. Remove the heatsink from the processor backplate.

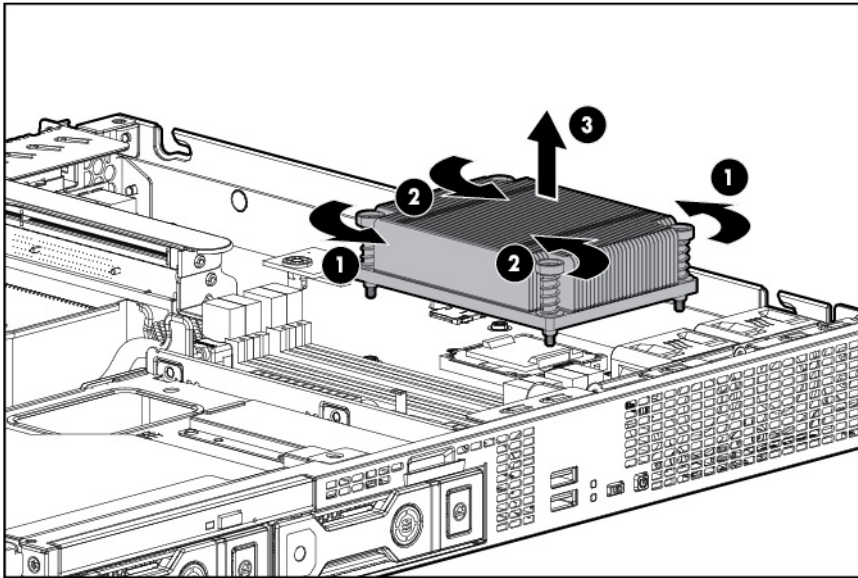

To replace the component:

1. Clean the old thermal grease from the processor with the alcohol swab. Allow the alcohol to evaporate before continuing.
2. Remove the thermal interface protective cover from the heatsink.

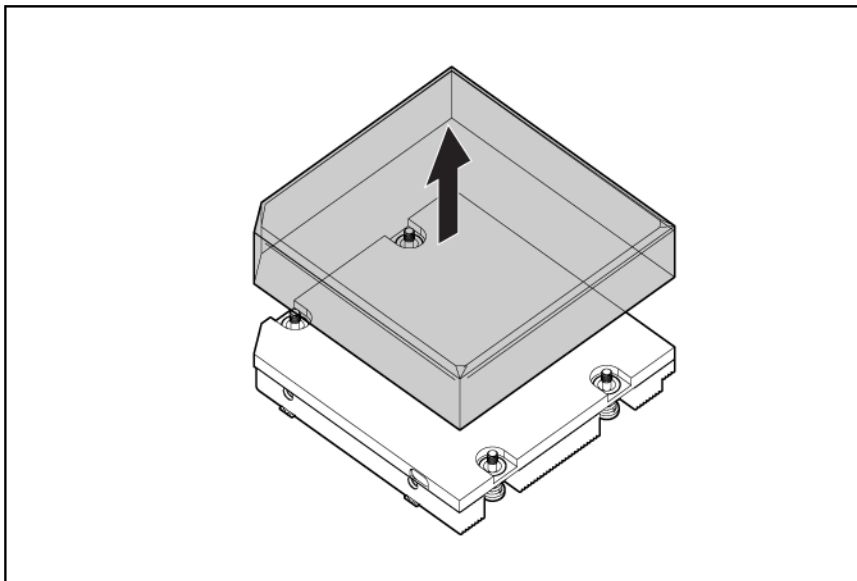

CAUTION: Heatsink retaining screws should be tightened or loosened in diagonally opposite pairs (in an "X" pattern). Do not overtighten the screws as this can damage the board, connectors, or screws. Use the wrench supplied with the system to reduce the possibility of overtightening the screws.

3. Install the heatsink:
 - a. Position the heatsink on the processor backplate.
 - b. Tighten one pair of diagonally opposite screws halfway, and then tighten the other pair of screws.

- c. Finish the installation by completely tightening the screws in the same sequence.

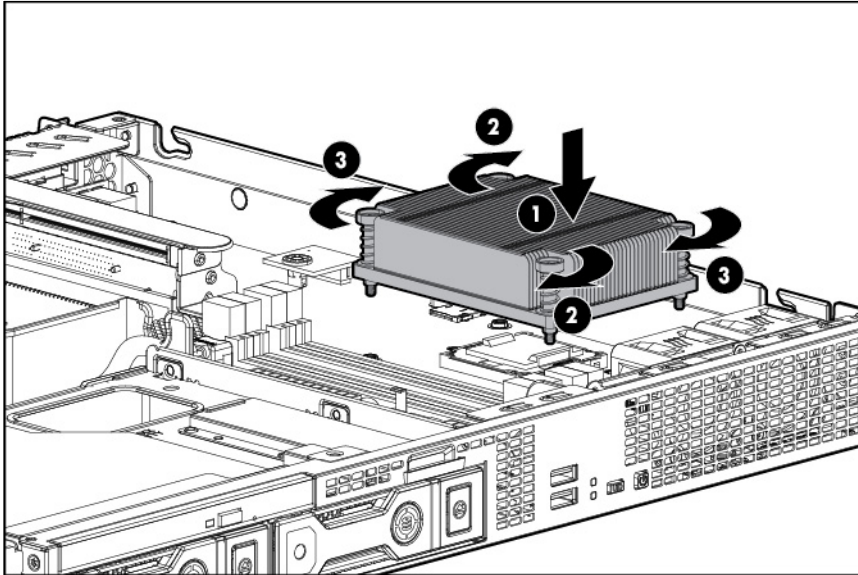

4. Install the air baffle.
5. Install the access panel.
6. Do one of the following:
 - o Slide the server into the rack.
 - o Install the server into the rack.
7. Connect the power cord to the server.
8. Connect the power cord to the power source.
9. Press the Power On/Standby button.

The server exits standby mode and applies full power to the system. The system power LED changes from amber to green.

Processor

! **WARNING:** To reduce the risk of personal injury from hot surfaces, allow the drives and the internal system components to cool before touching them.

⚠ **CAUTION:** To avoid damage to the processor and system board, only authorized personnel should attempt to replace or install the processor in this server.

🔧 **IMPORTANT:** If installing a processor with a faster speed, update the system ROM before installing the processor.

To remove the component:

1. Power down the server (on page 28).
2. Remove the power from the server:
 - a. Disconnect the power cord from the power source.
 - b. Disconnect the power cord from the server.
3. Do one of the following:

- a. Extend the server from the rack (on page 29).
- b. Remove the server from the rack (on page 30).
4. Remove the access panel ("Access panel" on page 35).
5. Remove the air baffle ("Air baffle" on page 36).
6. Remove the heatsink ("Heatsink" on page 45).

△ **CAUTION:** To avoid damage to the processor, do not touch the bottom of the processor, especially the contact area.

△ **CAUTION:** The pins on the processor socket are very fragile. Any damage to them may require replacing the system board.

7. Open the processor locking lever, and then open the processor retaining bracket.
8. Grasp the processor by the edges, and then lift it out of the socket.

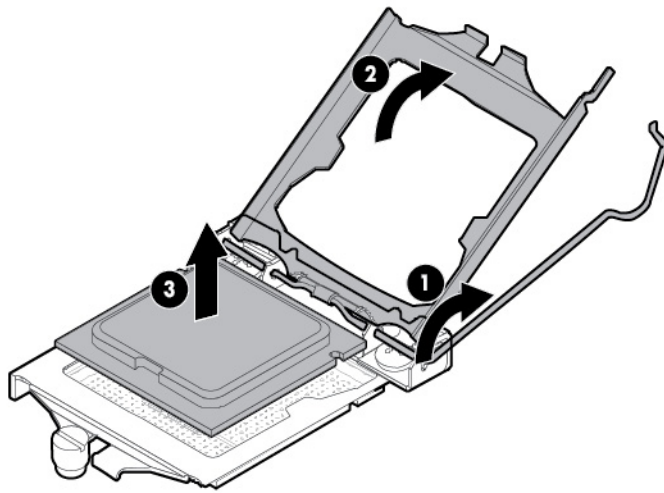

To replace the component:

△ **CAUTION: THE PINS ON THE SYSTEM BOARD ARE VERY FRAGILE AND EASILY DAMAGED.** To avoid damage to the system board:

- Do not touch the processor socket contacts.
 - Do not tilt or slide the processor when lowering the processor into the socket.
-

1. Install the processor. Use the notches on both sides of the processor to properly align it into the socket.

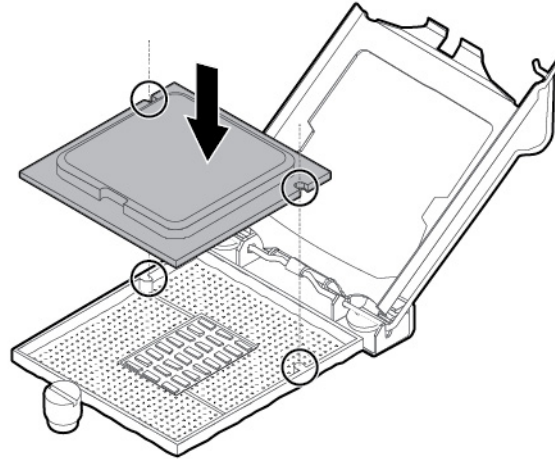

CAUTION: Be sure to close the processor socket retaining bracket before closing the processor locking lever. The lever should close without resistance. Forcing the lever closed can damage the processor and socket, requiring system board replacement.

2. Close the processor retaining bracket, and then secure the processor locking lever.

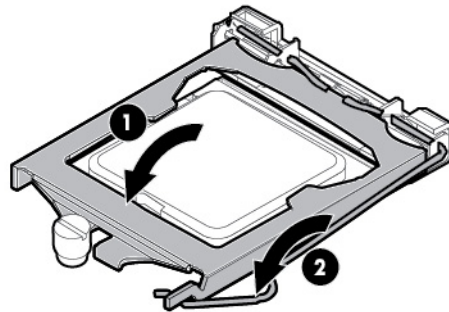

3. Clean the old thermal grease from the heatsink with the alcohol swab. Allow the alcohol to evaporate before continuing.
4. Apply all the grease to the top of the processor in the following pattern to ensure even distribution.

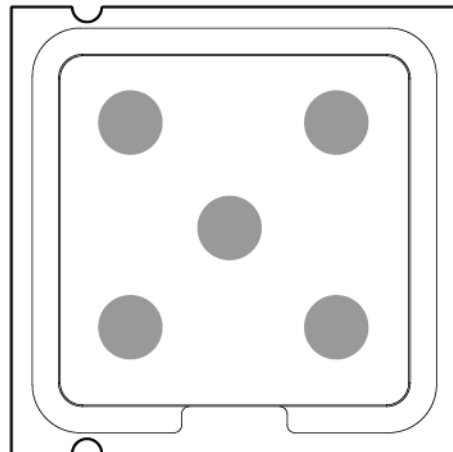

5. Install the heatsink ("[Heatsink](#)" on page [45](#)).
6. Install the air baffle.
7. Install the access panel.
8. Do one of the following:
 - o Slide the server into the rack.
 - o Install the server into the rack.
9. Connect the power cord to the server.
10. Connect the power cord to the power source.
11. Press the Power On/Standby button.

The server exits standby mode and applies full power to the system. The system power LED changes from amber to green.

System battery

If the server no longer automatically displays the correct date and time, then replace the battery that provides power to the real-time clock. Under normal use, battery life is 5 to 10 years.



WARNING: The computer contains an internal lithium manganese dioxide, a vanadium pentoxide, or an alkaline battery pack. A risk of fire and burns exists if the battery pack is not properly handled. To reduce the risk of personal injury:

- Do not attempt to recharge the battery.
 - Do not expose the battery to temperatures higher than 60°C (140°F).
 - Do not disassemble, crush, puncture, short external contacts, or dispose of in fire or water.
 - Replace only with the spare designated for this product.
-

To remove the component:

1. Power down the server (on page [28](#)).
2. Remove the power from the server:
 - a. Disconnect the power cord from the power source.
 - b. Disconnect the power cord from the server.
3. Do one of the following:
 - o Extend the server from the rack (on page [29](#)).
 - o Remove the server from the rack (on page [30](#)).
4. Remove the access panel ("[Access panel](#)" on page [35](#)).
5. Remove the air baffle ("[Air baffle](#)" on page [36](#)).
6. Locate the battery on the system board ("[System board components](#)" on page [78](#)).

7. Remove the battery.

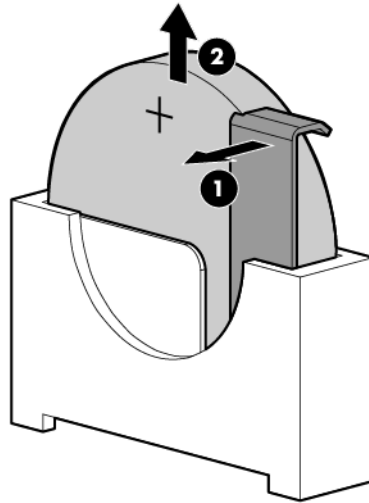

IMPORTANT: Replacing the system board battery resets the system ROM to its default configuration. After replacing the battery, reconfigure the system through RBSU.

To replace the component, reverse the removal procedure.

For more information about battery replacement or proper disposal, contact an authorized reseller or an authorized service provider.

PCI riser cage

To remove the component:

1. Power down the server (on page 28).
2. Remove the power from the server:
 - a. Disconnect the power cord from the power source.
 - b. Disconnect the power cord from the server.
3. Do one of the following:
 - o Extend the server from the rack (on page 29).
 - o Remove the server from the rack (on page 30).
4. Remove the access panel ("Access panel" on page 35).
5. Disconnect all cables connected to existing expansion boards.

6. Lift the PCI riser cage to unseat the PCI riser board.

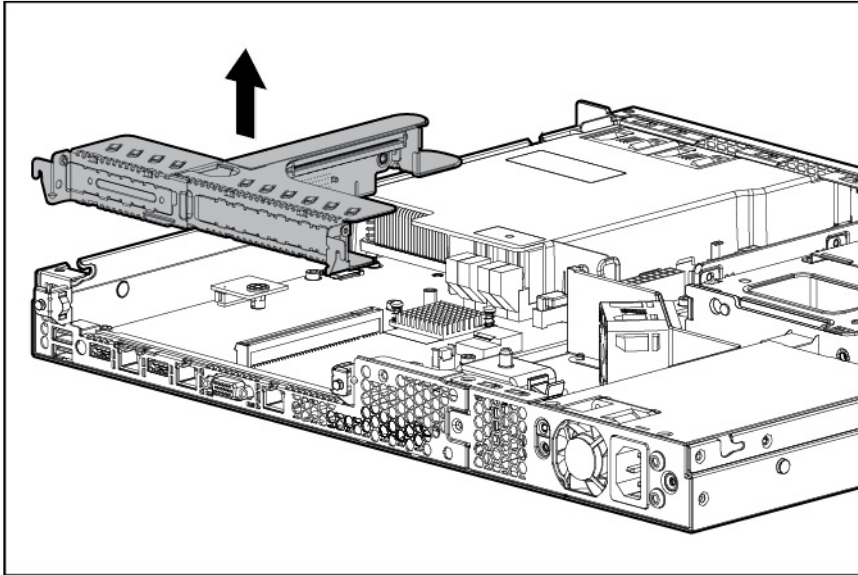

To replace the component, reverse the removal procedure.

Expansion board options

The server has both full-height and low-profile expansion slots for controller option installation ("[PCIe riser board slot definitions](#)" on page 77). Controller options with internal cable connections should be installed in the full-height riser board slot 1.

For more information about product features, specifications, options, configurations, and compatibility, see the product QuickSpecs on the HP website (<http://www.hp.com/go/qs>).

⚠ CAUTION: To prevent improper cooling and thermal damage, do not operate the server unless all expansion slots have either an expansion slot cover or an expansion board installed.

To install the component:

1. Power down the server (on page 28).
2. Remove the power from the server:
 - a. Disconnect the power cord from the power source.
 - b. Disconnect the power cord from the server.
3. Do one of the following:
 - o Extend the server from the rack (on page 29).
 - o Remove the server from the rack (on page 30).
4. Remove the access panel ("[Access panel](#)" on page 35).
5. Remove the PCI riser cage ("[PCI riser cage](#)" on page 51).

6. Identify the expansion slot compatible with the new option, and then remove the cover opposite that slot.

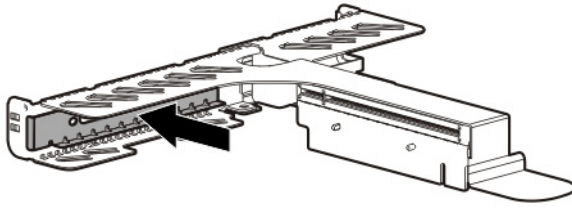

7. Verify that any switches or jumpers on the expansion board are set properly. For more information, see the documentation that ships with the option.
8. Install the expansion board. Verify that the board is firmly seated in the slot.

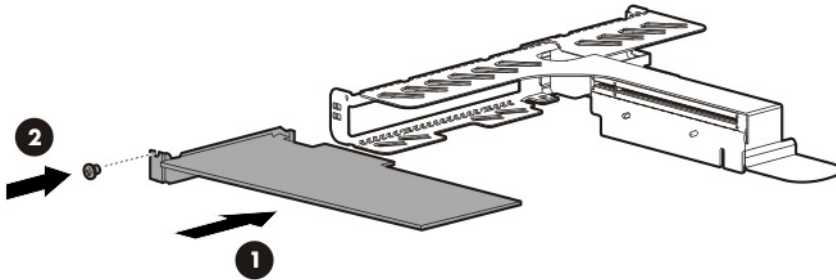

9. Install the PCI riser cage.



IMPORTANT: The server does not power up if the PCI riser cage is not seated properly.

10. Connect all necessary internal cabling to the expansion board. For more information on these cabling requirements, see the documentation that ships with the option.
11. Install the access panel.
12. Do one of the following:
 - Slide the server into the rack.
 - Install the server into the rack.
13. Connect all necessary external cabling to the expansion board. For more information on these cabling requirements, see the documentation that ships with the option.
14. Connect the peripheral devices to the server.
15. Connect the power cord to the server.
16. Connect the power cord to the power source.
17. Power up the server.

PCIe riser board

To remove the component:

1. Power down the server (on page 28).
2. Remove the power from the server:
 - a. Disconnect the power cord from the power source.

- b. Disconnect the power cord from the server.
3. Do one of the following:
 - o Extend the server from the rack (on page 29).
 - o Remove the server from the rack (on page 30).
4. Remove the access panel ("Access panel" on page 35).
5. Remove the PCI riser cage ("PCI riser cage" on page 51).
6. Remove any existing expansion board from the riser board.
7. Remove the PCIe riser board.

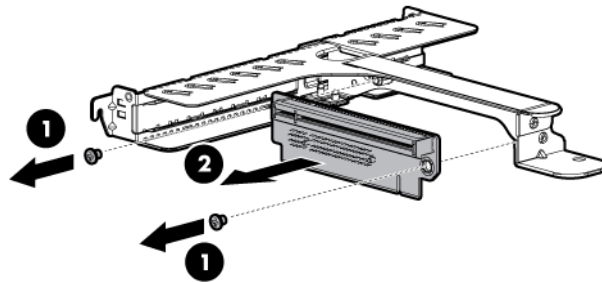

To replace the component, reverse the removal procedure.

Flash-backed write cache procedures

The following types of procedures are provided for the FBWC option:

- Removal and replacement of failed components:
 - o Removing the cache module ("FBWC module" on page 54)
 - o Removing the capacitor pack ("Capacitor pack" on page 55)
- Recovery of cached data from a failed server ("Recovering data from the flash-backed write cache" on page 57)

CAUTION: Do not detach the cable that connects the battery pack or capacitor pack to the cache module. Detaching the cable causes all data in the cache module to be lost.

FBWC module

CAUTION: The cache module connector does not use the industry-standard DDR3 mini-DIMMs. Do not use the controller with cache modules designed for other controller models, because the controller can malfunction and you can lose data. Also, do not transfer this cache module to an unsupported controller model, because you can lose data.

CAUTION: In systems that use external data storage, be sure that the server is the first unit to be powered down and the last to be powered back up. Taking this precaution ensures that the system does not erroneously mark the drives as failed when the server is powered up.

To remove the component:

1. Power down the server (on page 28).
2. Remove the power from the server:

- a. Disconnect the power cord from the power source.
 - b. Disconnect the power cord from the server.
3. Do one of the following:
 - o Extend the server from the rack (on page 29).
 - o Remove the server from the rack (on page 30).
4. Remove the access panel ("Access panel" on page 35).
5. Remove the PCI riser cage ("PCI riser cage" on page 51).

⚠ CAUTION: When connecting or disconnecting the capacitor pack cable, the connectors on the cache module and cable are susceptible to damage. Avoid excessive force and use caution to avoid damage to these connectors.

6. Disconnect the capacitor pack cable from the cache module.

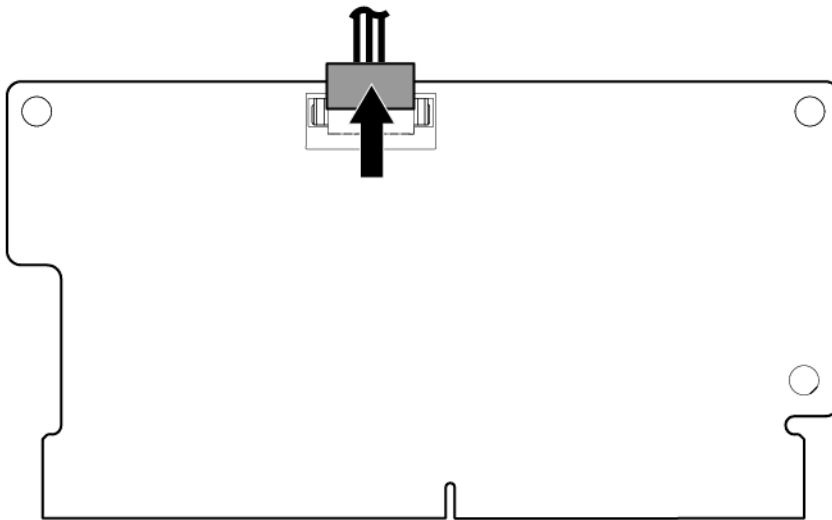

7. Remove the cache module.

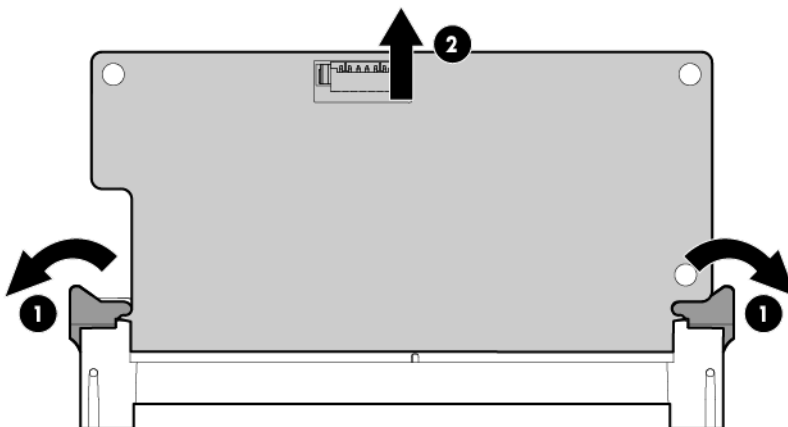

To replace the component, reverse the removal procedure.

Capacitor pack



CAUTION: In systems that use external data storage, be sure that the server is the first unit to be powered down and the last to be powered back up. Taking this precaution ensures that the system does not erroneously mark the drives as failed when the server is powered up.

To remove the component:

1. Power down the server (on page 28).
2. Remove the power from the server:
 - a. Disconnect the power cord from the power source.
 - b. Disconnect the power cord from the server.
3. Do one of the following:
 - o Extend the server from the rack (on page 29).
 - o Remove the server from the rack (on page 30).
4. Remove the access panel ("Access panel" on page 35).
5. Remove the PCI riser cage ("PCI riser cage" on page 51).
6. If the existing cache module is connected to a capacitor pack, observe the FBWC module LEDs:
 - o If a backup is in progress, wait for the backup to complete.
 - o If the backup is complete, or if the cache has failed, remove the controller from the server, and then continue with the next step.
7. Disconnect the capacitor pack cable from the cache module.

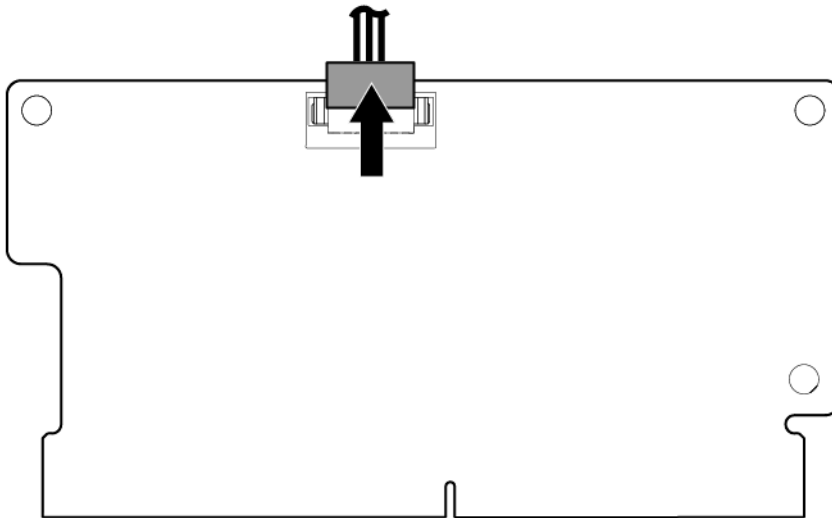

8. Release the capacitor pack cable from the cable clip.
9. Open the capacitor pack holder.

10. Remove the capacitor pack.

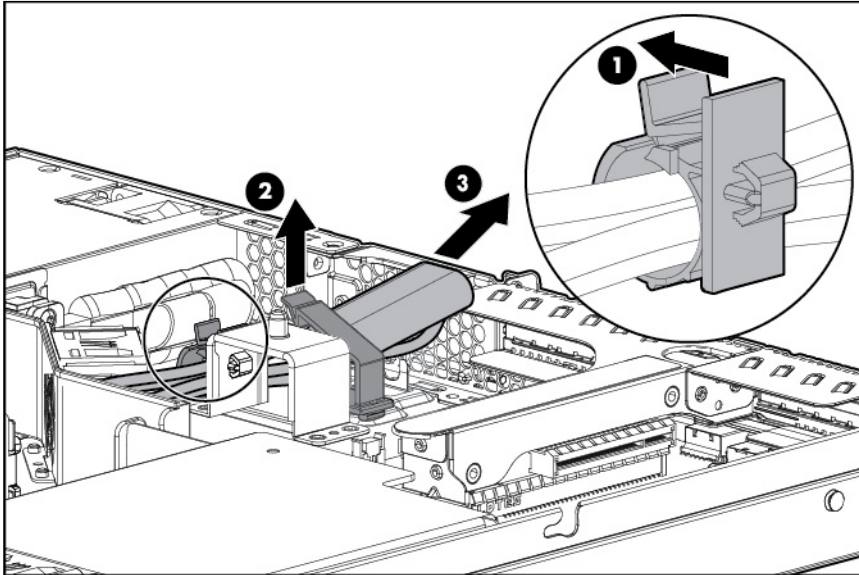

To replace the component, reverse the removal procedure.

Recovering data from the flash-backed write cache

If the server fails, use the following procedure to recover data temporarily stored in the FBWC.

CAUTION: Before starting this procedure, read the information about protecting against electrostatic discharge ("[Preventing electrostatic discharge](#)" on page 25).

1. Perform one of the following:
 - Set up a recovery server using an identical server model. Do not install any internal drives or FBWC in this server. (HP recommends this option.)
 - Find a server that has enough empty drive bays to accommodate all the drives from the failed server and that meets all the other requirements for drive and array migration.
2. Power down the failed server ("[Power down the server](#)" on page 28).
3. Transfer the drives from the failed server to the recovery server.
4. Perform one of the following:
 - If the array controller has failed, remove the cache module and capacitor pack from the failed array controller, and install the cache module and capacitor pack on an identical array controller model in the recovery server.
 - If the server has failed, remove the controller, cache module, and capacitor pack from the failed server, and install the controller, cache module, and capacitor pack in the recovery server.
5. Power up the recovery server. If there was data in the cache at the time of the controller or server failure, a 1792 POST message appears, stating that valid data was flushed from the cache. This data is now stored on the drives in the recovery server. You can now transfer the drives (and controller, if one is used) to another server.

If the drives are migrated to different drive positions or there are volumes present in the recovery server, a 1724 POST message appears, stating that logical drive configuration has been updated automatically.

Center fan assembly

CAUTION: To prevent improper cooling and thermal damage, do not operate the server unless all bays are populated with either a component or a blank.

To remove the component:

1. Power down the server (on page 28).
2. Remove the power from the server:
 - a. Disconnect the power cord from the power source.
 - b. Disconnect the power cord from the server.
3. Remove the server from the rack (on page 30).
4. Remove the access panel ("Access panel" on page 35).
5. If an expansion board is installed in the riser board slot 1, remove the PCI riser cage ("PCI riser cage" on page 51).
6. Disconnect the fan cable.
7. Turn the server bottom side up, and then remove the screws securing the center fan bracket.

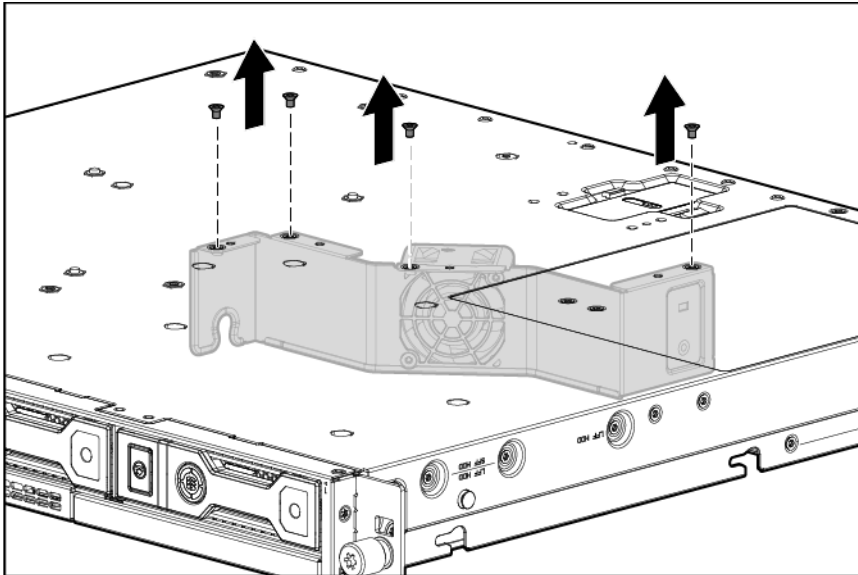

8. Return the server to its normal position.
9. Remove the system cables that run over the cable management cutout of the center fan bracket.

10. Remove the fan assembly.

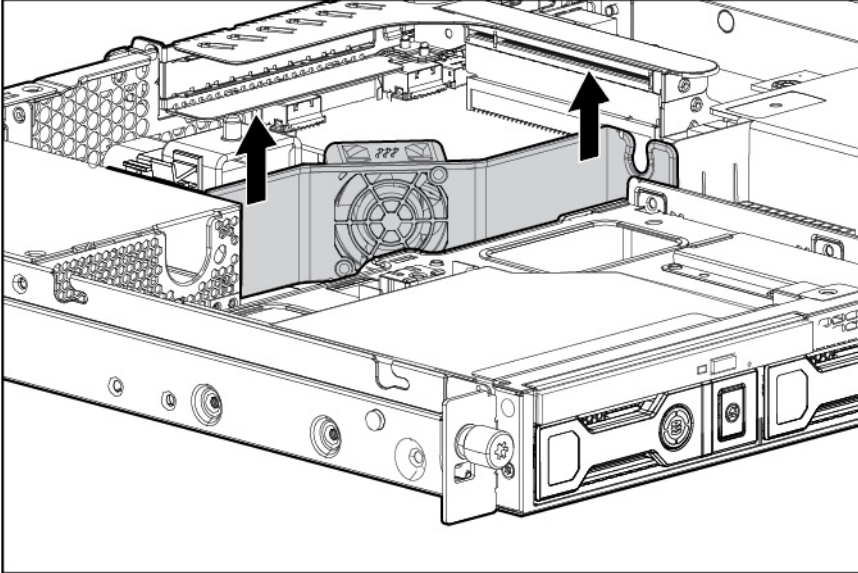

To replace the component, reverse the removal procedure.

Internal USB connector

To remove the component:

1. Power down the server (on page 28).
2. Remove the power from the server:
 - a. Disconnect the power cord from the power source.
 - b. Disconnect the power cord from the server.
3. Do one of the following:
 - o Extend the server from the rack (on page 29).
 - o Remove the server from the rack (on page 30).
4. Remove the access panel ("Access panel" on page 35).
5. If an expansion board is installed in the riser board slot 1, remove the PCI riser cage ("PCI riser cage" on page 51).
6. Disconnect the internal USB connector cable from the system board.

7. Remove the internal USB connector.

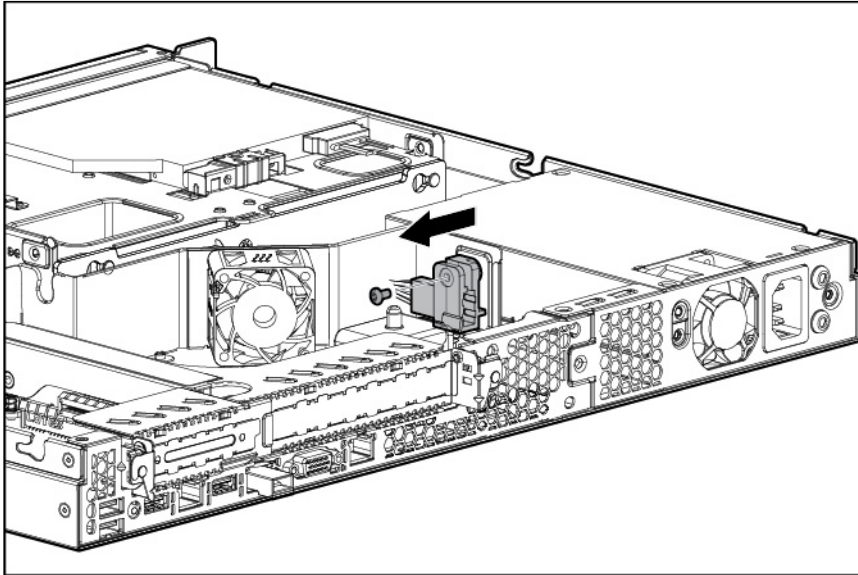

To replace the component, reverse the removal procedure.

Integrated power supply rear cover

To remove the component:

1. Power down the server (on page 28).
2. Remove the power from the server:
 - a. Disconnect the power cord from the power source.
 - b. Disconnect the power cord from the server.
3. Do one of the following:
 - o Extend the server from the rack (on page 29).
 - o Remove the server from the rack (on page 30).
4. Remove the access panel ("Access panel" on page 35).

5. Remove the integrated power supply rear cover.

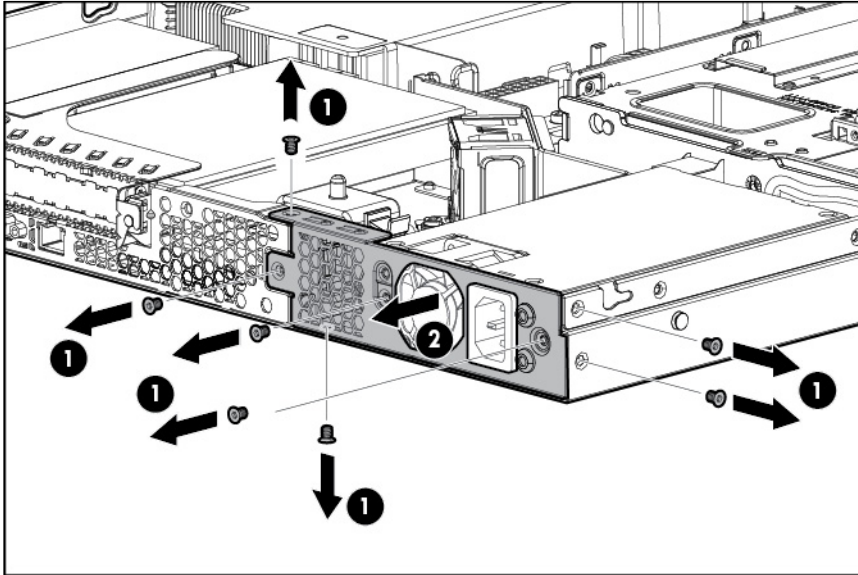

To replace the component, reverse the removal procedure.

Integrated power supply

To remove the component:

1. Power down the server (on page 28).
2. Remove the power from the server:
 - a. Disconnect the power cord from the power source.
 - b. Disconnect the power cord from the server.
3. Remove the server from the rack (on page 30).
4. If the server is installed in a friction rail system, remove the friction rails from the chassis. For more information, see the documentation that ships with the rail system.
5. Remove the access panel ("[Access panel](#)" on page 35).



WARNING: To reduce the risk of personal injury from hot surfaces, allow the power supply or power supply blank to cool before touching it.

6. Disconnect all power supply cables from the system board and drive cage.

7. Remove the power supply.

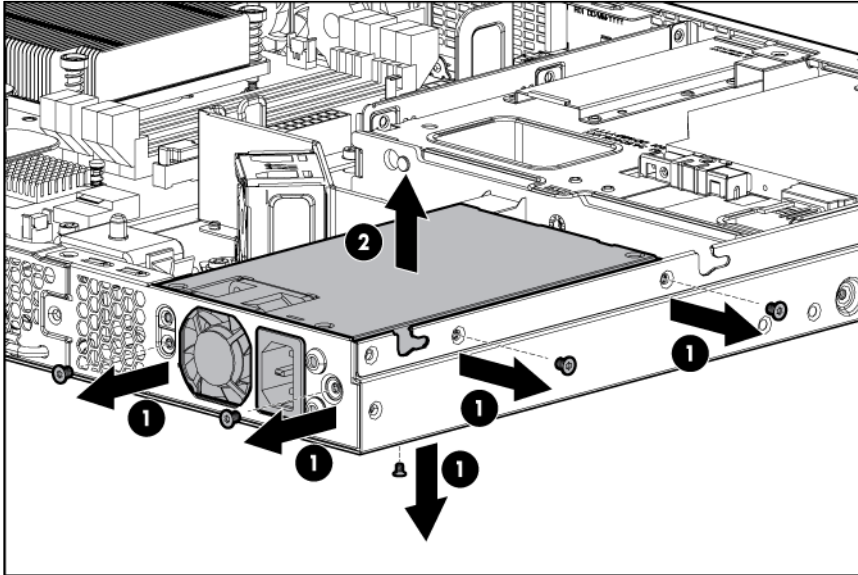

To replace the component, reverse the removal procedure.

HP 750 W CS -48 V DC power supply enablement kit

To remove the component:

1. Power down the server (on page 28).
2. Remove the power from the server:
 - a. Disconnect the power cord from the power source.
 - b. Disconnect the power cord from the server.
3. Do one of the following:
 - o Extend the server from the rack (on page 29).
 - o Remove the server from the rack (on page 30).
4. Remove the access panel ("Access panel" on page 35).



WARNING: To reduce the risk of personal injury from hot surfaces, allow the power supply or power supply blank to cool before touching it.

5. Remove the power supply ("HP CS power supply" on page 33).
6. Disconnect the Mini-SAS cable from the drive cage backplane.
7. Disconnect all cables from the power distribution board.

8. Remove the power distribution board.

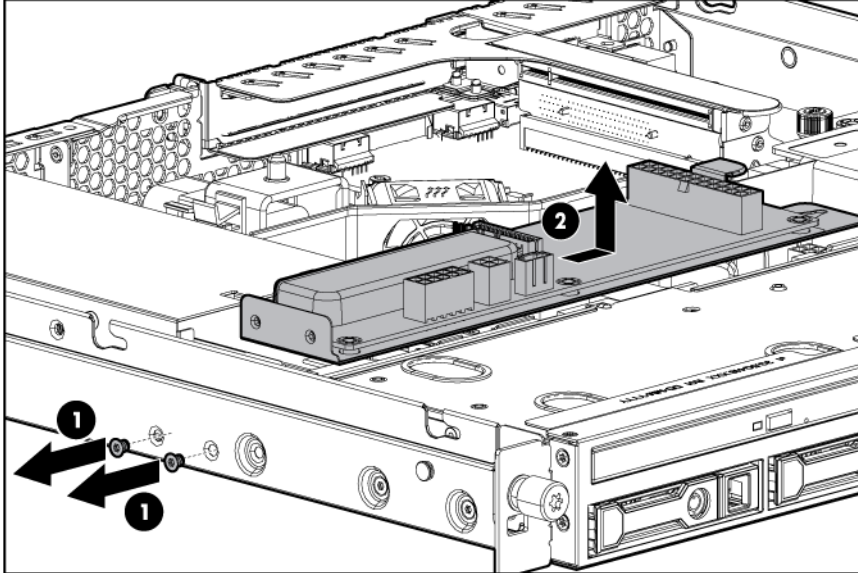

To replace the component, reverse the removal procedure.

HP CS power supply cage

To remove the component:

1. Power down the server (on page 28).
2. Remove the power from the server:
 - a. Disconnect the power cord from the power source.
 - b. Disconnect the power cord from the server.
3. Do one of the following:
 - o Extend the server from the rack (on page 29).
 - o Remove the server from the rack (on page 30).
4. Remove the access panel ("Access panel" on page 35).



WARNING: To reduce the risk of personal injury from hot surfaces, allow the power supply or power supply blank to cool before touching it.

5. Remove the power supply ("HP CS power supply" on page 33).

6. Remove the power supply cage.

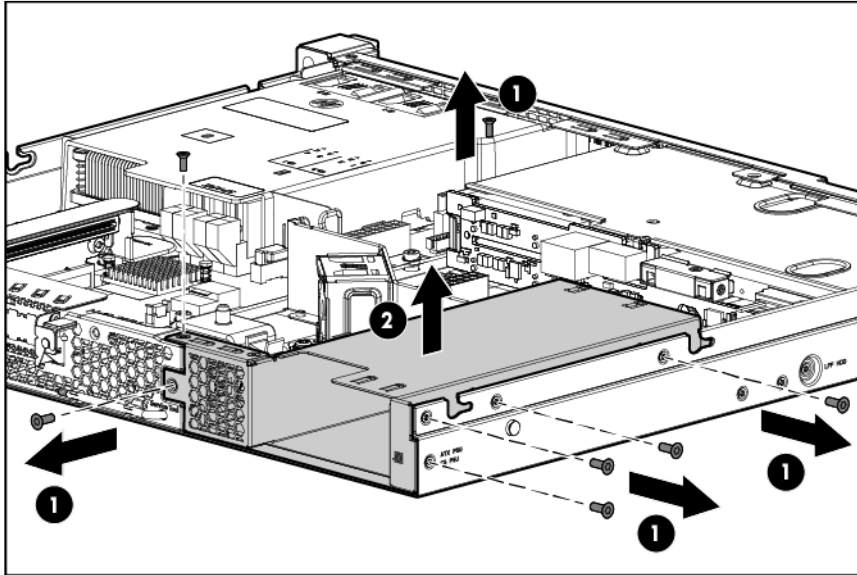

To replace the component, reverse the removal procedure.

System board



CAUTION: To avoid ESD damage, when removing electrostatic-sensitive components from the failed system board, place the components on a static-dissipating work surface or inside separate antistatic bags.

To remove the system board:

1. Power down the server (on page 28).
2. Remove the power from the server:
 - a. Disconnect the power cord from the power source.
 - b. Disconnect the power cord from the server.
3. Do one of the following:
 - o Extend the server from the rack (on page 29).
 - o Remove the server from the rack (on page 30).
4. Remove the access panel ("Access panel" on page 35).
5. Remove the air baffle ("Air baffle" on page 36).
6. Disconnect all cables connected to existing expansion boards.
7. Remove the PCI riser cage ("PCI riser cage" on page 51).
8. Remove the front fan cage assembly.
9. Disconnect all cables connected to the system board.
10. Remove all DIMMs ("DIMMs" on page 44).



WARNING: To reduce the risk of personal injury from hot surfaces, allow the heatsink to cool before touching it.

- △ **CAUTION:** Heatsink retaining screws should be tightened or loosened in diagonally opposite pairs (in an "X" pattern). Do not overtighten the screws as this can damage the board, connectors, or screws. Use the wrench supplied with the system to reduce the possibility of overtightening the screws.

11. Remove the heatsink:
- Loosen one pair of diagonally opposite screws halfway, and then loosen the other pair of screws.
 - Completely loosen all screws in the same sequence.
 - Remove the heatsink from the processor backplate.

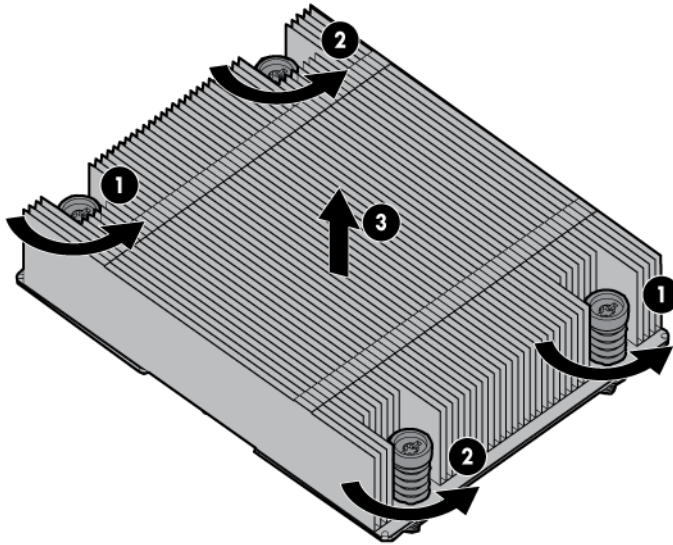

- △ **CAUTION:** To avoid damage to the processor, do not touch the bottom of the processor, especially the contact area.

12. Open the processor locking lever, and then open the processor retaining bracket.
13. Grasp the processor by the edges, and then lift it out of the socket.

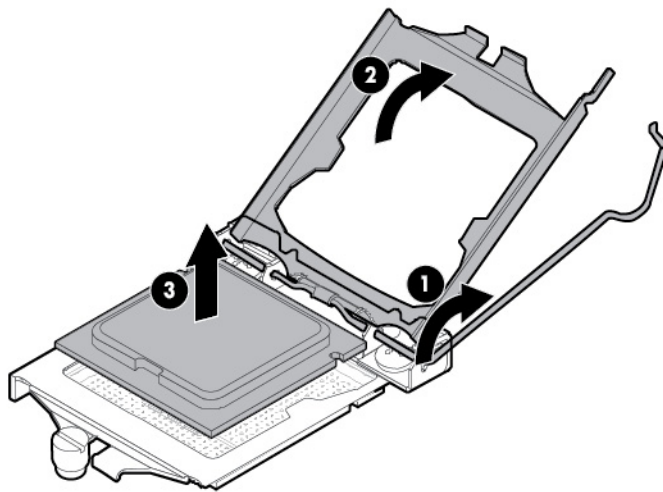

14. Remove the failed system board.

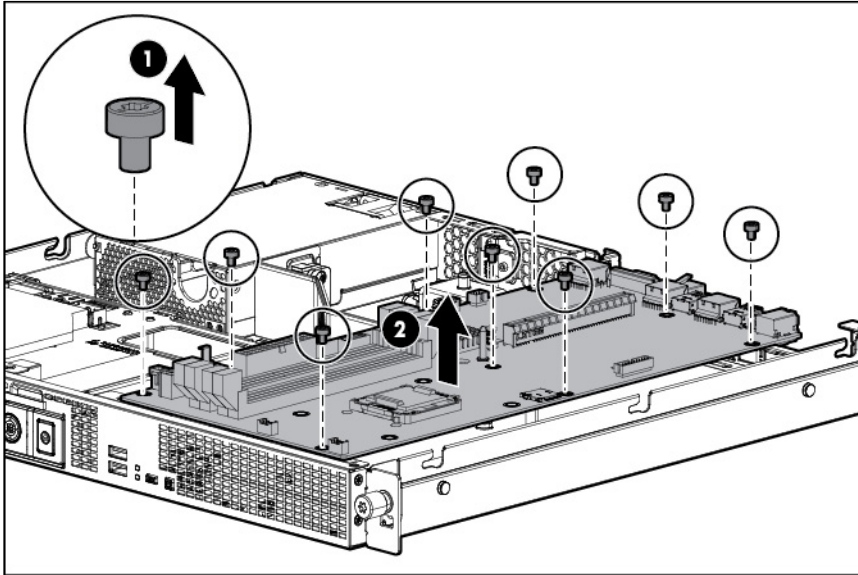

To replace the system board:

1. Install the system board.

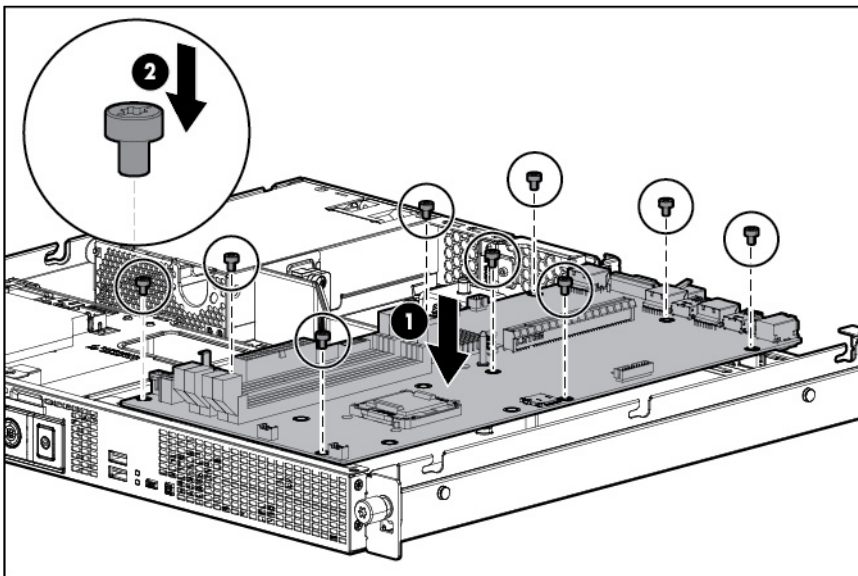

△ **CAUTION:** Failure to completely open the processor locking lever prevents the processor from seating during installation, leading to hardware damage.

△ **CAUTION:** To avoid damage to the processor, do not touch the bottom of the processor, especially the contact area.

2. Open the processor locking lever, and then open the processor retaining bracket.

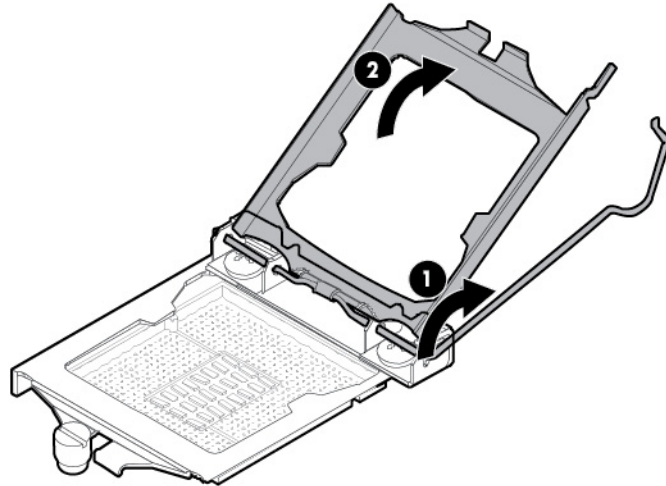

3. Remove the processor socket cover.

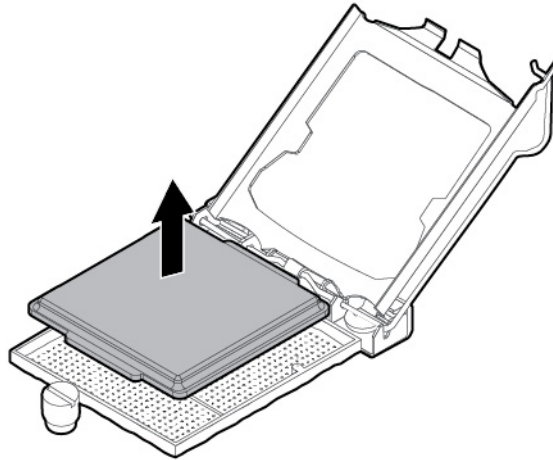

CAUTION: THE PINS ON THE SYSTEM BOARD ARE VERY FRAGILE AND EASILY DAMAGED. To avoid damage to the system board:

- Do not touch the processor socket contacts.
- Do not tilt or slide the processor when lowering the processor into the socket.

4. Install the processor. Use the notches on both sides of the processor to properly align it into the socket.

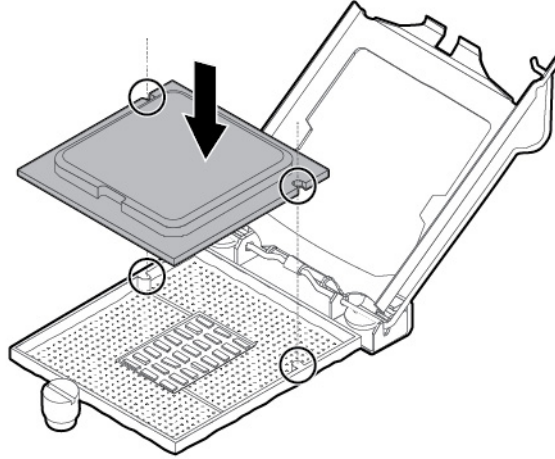

CAUTION: Be sure to close the processor socket retaining bracket before closing the processor locking lever. The lever should close without resistance. Forcing the lever closed can damage the processor and socket, requiring system board replacement.

5. Close the processor retaining bracket, and then secure the processor locking lever.

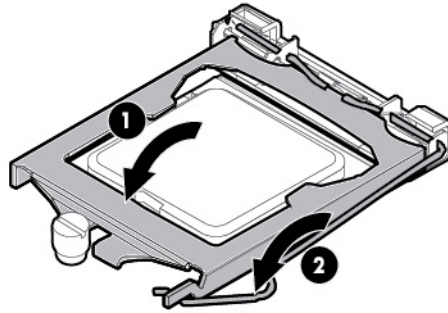

6. Clean the old thermal grease from the heatsink and the top of the processor with the alcohol swab. Allow the alcohol to evaporate before continuing.
7. Apply all the grease to the top of the processor in the following pattern to ensure even distribution.

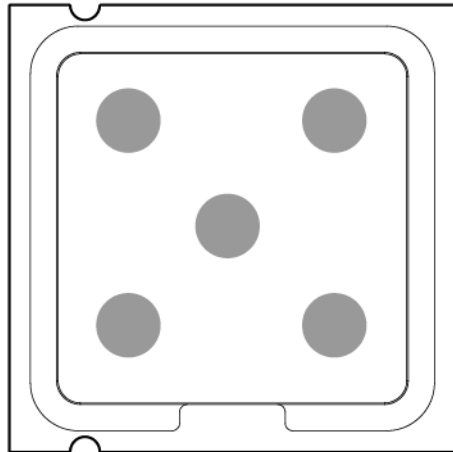

CAUTION: Heatsink retaining screws should be tightened or loosened in diagonally opposite pairs (in an "X" pattern). Do not overtighten the screws as this can damage the board, connectors, or screws. Use the wrench supplied with the system to reduce the possibility of overtightening the screws.

8. Install the heatsink:
 - a. Position the heatsink on the processor backplate.
 - b. Tighten one pair of diagonally opposite screws halfway, and then tighten the other pair of screws.
 - c. Finish the installation by completely tightening the screws in the same sequence.

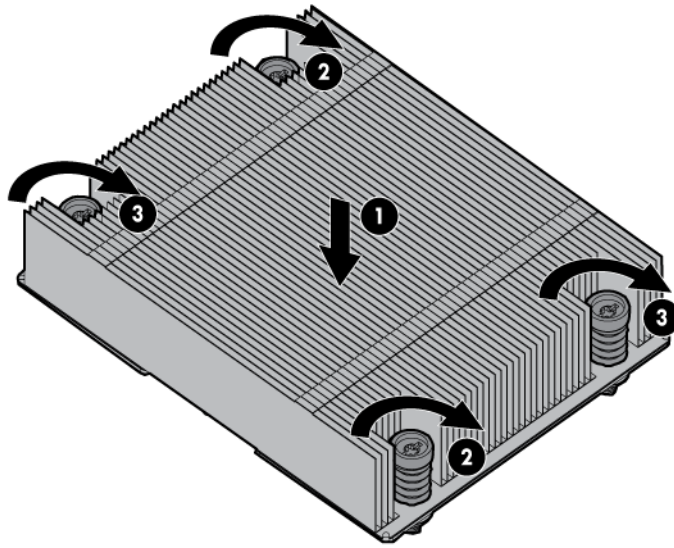

CAUTION: When returning a damaged system board to HP, always install all processor socket covers to prevent damage to the processor sockets and system board.

9. Install the DIMMs.
10. Connect all cables disconnected from the failed system board.
11. Install the front fan cage.
12. Install the PCI riser cage.
13. Connect all necessary internal cabling to the expansion board. For more information on these cabling requirements, see the documentation that ships with the option.
14. Install the air baffle.
15. Install the access panel.
16. Do one of the following:
 - a. Slide the server into the rack.
 - b. Install the server into the rack.
17. Connect the power cord to the server.
18. Connect the power cord to the power source.
19. Press the Power On/Standby button.

The server exits standby mode and applies full power to the system. The system power LED changes from amber to green.



IMPORTANT: Install all components with the same configuration that was used on the failed system board.

After you replace the system board, you must re-enter the server serial number and the product ID.

1. During the server startup sequence, press the **F9** key to access RBSU.
2. Select the **Advanced Options** menu.
3. Select **Service Options**.
4. Select **Serial Number**. The following warning appears:
Warning: The serial number should ONLY be modified by qualified service personnel. This value should always match the serial number located on the chassis.
5. Press the **Enter** key to clear the warning.
6. Enter the serial number and press the **Enter** key.
7. Select **Product ID**. The following warning appears:
Warning: The Product ID should ONLY be modified by qualified service personnel. This value should always match the Product ID located on the chassis.
8. Enter the product ID and press the **Enter** key.
9. Press the **Esc** key to close the menu.
10. Press the **Esc** key to exit RBSU.
11. Press the **F10** key to confirm exiting RBSU. The server automatically reboots.

HP Trusted Platform Module

The TPM is not a customer-removable part.



CAUTION: Any attempt to remove an installed TPM from the system board breaks or disfigures the TPM security rivet. Upon locating a broken or disfigured rivet on an installed TPM, administrators should consider the system compromised and take appropriate measures to ensure the integrity of the system data.

If you suspect a TPM board failure, leave the TPM installed and remove the system board. Contact an HP authorized service provider for a replacement system board and TPM board.

Troubleshooting

Troubleshooting resources

The *HP ProLiant Gen8 Troubleshooting Guide, Volume I: Troubleshooting* provides procedures for resolving common problems and comprehensive courses of action for fault isolation and identification, issue resolution, and software maintenance on ProLiant servers and server blades. To view the guide, select a language:

- English (http://www.hp.com/support/ProLiant_TSG_v1_en)
- French (http://www.hp.com/support/ProLiant_TSG_v1_fr)
- Spanish (http://www.hp.com/support/ProLiant_TSG_v1_sp)
- German (http://www.hp.com/support/ProLiant_TSG_v1_gr)
- Japanese (http://www.hp.com/support/ProLiant_TSG_v1_jp)
- Simplified Chinese (http://www.hp.com/support/ProLiant_TSG_v1_sc)

The *HP ProLiant Gen8 Troubleshooting Guide, Volume II: Error Messages* provides a list of error messages and information to assist with interpreting and resolving error messages on ProLiant servers and server blades. To view the guide, select a language:

- English (http://www.hp.com/support/ProLiant_EMG_v1_en)
- French (http://www.hp.com/support/ProLiant_EMG_v1_fr)
- Spanish (http://www.hp.com/support/ProLiant_EMG_v1_sp)
- German (http://www.hp.com/support/ProLiant_EMG_v1_gr)
- Japanese (http://www.hp.com/support/ProLiant_EMG_v1_jp)
- Simplified Chinese (http://www.hp.com/support/ProLiant_EMG_v1_sc)

Diagnostic tools

HP product QuickSpecs

For more information about product features, specifications, options, configurations, and compatibility, see the product QuickSpecs on the HP website (<http://www.hp.com/go/qs>).

HP Insight Diagnostics

HP Insight Diagnostics is a proactive server management tool, available in both offline and online versions, that provides diagnostics and troubleshooting capabilities to assist IT administrators who verify server installations, troubleshoot problems, and perform repair validation.

HP Insight Diagnostics Offline Edition performs various in-depth system and component testing while the OS is not running. To run this utility, boot the server using Intelligent Provisioning.

HP Insight Diagnostics Online Edition is a web-based application that captures system configuration and other related data needed for effective server management. Available in Microsoft Windows and Linux versions, the utility helps to ensure proper system operation.

For more information or to download the utility, see the HP website (<http://www.hp.com/servers/diags>). HP Insight Diagnostics Online Edition is also available in the SPP.

HP Insight Diagnostics survey functionality

HP Insight Diagnostics (on page 72) provides survey functionality that gathers critical hardware and software information on ProLiant servers.

This functionality supports operating systems that are supported by the server. For operating systems supported by the server, see the HP website (<http://www.hp.com/go/supportos>).

If a significant change occurs between data-gathering intervals, the survey function marks the previous information and overwrites the survey data files to reflect the latest changes in the configuration.

Survey functionality is installed with every Intelligent Provisioning-assisted HP Insight Diagnostics installation, or it can be installed through the SPP.

HP Insight Remote Support software

HP strongly recommends that you register your device for remote support to enable enhanced delivery of your HP Warranty, HP Care Pack Service, or HP contractual support agreement. HP Insight Remote Support supplements your monitoring continuously to ensure maximum system availability by providing intelligent event diagnosis, and automatic, secure submission of hardware event notifications to HP, which will initiate a fast and accurate resolution, based on your product's service level. Notifications may be sent to your authorized HP Channel Partner for onsite service, if configured and available in your country.

For more information, see *HP Insight Remote Support and Insight Online Setup Guide for ProLiant Gen8 Servers and BladeSystem c-Class Enclosures* on the HP website (<http://www.hp.com/go/enterprise/docs>).

HP Insight Remote Support is available as part of HP Warranty, HP Care Pack Service, or HP contractual support agreement.

HP ROM-Based Setup Utility

RBSU is a configuration utility embedded in HP ProLiant servers that performs a wide range of configuration activities that can include the following:

- Configuring system devices and installed options
- Enabling and disabling system features
- Displaying system information
- Selecting the primary boot controller
- Configuring memory options
- Language selection

For more information on RBSU, see the *HP ROM-Based Setup Utility User Guide* on the Documentation CD or the HP RBSU Information Library (<http://www.hp.com/go/rbsu/docs>).

Integrated Management Log

The IML records hundreds of events and stores them in an easy-to-view form. The IML timestamps each event with 1-minute granularity.

You can view recorded events in the IML in several ways, including the following:

- From within HP SIM
- From within operating system-specific IML viewers:
 - For Windows: IML Viewer
 - For Linux: IML Viewer Application
- From within the iLO 4 web interface
- From within HP Insight Diagnostics (on page 72)

USB support and functionality

USB support

HP provides standard USB 2.0 support, standard USB 3.0 support, and legacy USB support. Standard support is provided by the OS through the appropriate USB device drivers.

Before the OS loads, HP provides support for USB 2.0 devices through legacy USB support, which is enabled by default in the system ROM. USB 3.0 ports are not functional before the OS loads. The native OS provides USB 3.0 support through appropriate xHCI drivers.

Legacy USB support provides USB functionality in environments where USB support is not available normally. Specifically, HP provides legacy USB functionality for the following:

- POST

- RBSU
- Diagnostics
- DOS
- Operating environments which do not provide native USB support

Internal USB functionality

An internal USB connector is available for use with security key devices and USB drive keys. This solution provides for use of a permanent USB key installed in the internal connector, avoiding issues of clearance on the front of the rack and physical access to secure data.

External USB functionality

HP provides external USB support to enable local connection of USB devices for server administration, configuration, and diagnostic procedures.

For additional security, external USB functionality can be disabled through RBSU.

Automatic Server Recovery

ASR is a feature that causes the system to restart when a catastrophic operating system error occurs, such as a blue screen, ABEND (does not apply to HP ProLiant DL980 Servers), or panic. A system fail-safe timer, the ASR timer, starts when the System Management driver, also known as the Health Driver, is loaded. When the operating system is functioning properly, the system periodically resets the timer. However, when the operating system fails, the timer expires and restarts the server.

ASR increases server availability by restarting the server within a specified time after a system hang. At the same time, the HP SIM console notifies you by sending a message to a designated pager number that ASR has restarted the system. You can disable ASR from the System Management Homepage or through RBSU.

Component identification

Front panel components

- Two-bay LFF drive model

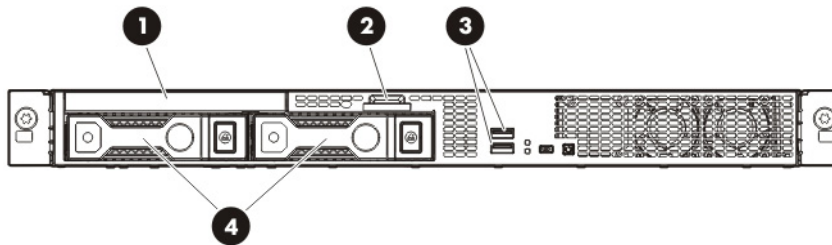

Item	Description
1	Optical drive blank
2	Serial number/iLO information pull tab*
3	USB 2.0 connectors
4	LFF drives (8.89 cm, 3.5 in)

* The serial number/iLO information pull tab is double-sided. The top side shows the server serial number, and the reverse side shows the default iLO account information. The same information is printed on a label attached to the chassis.

- Four-bay SFF drive model

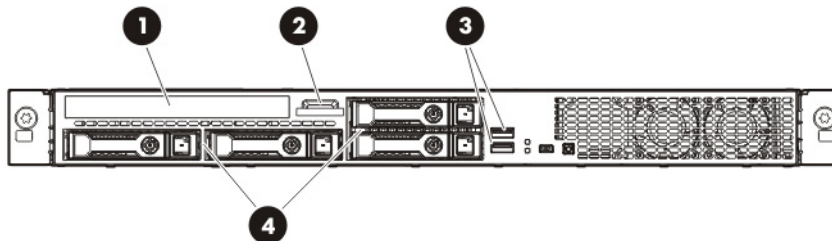

Item	Description
1	Optical drive blank
2	Serial number/iLO information pull tab*
3	USB 2.0 connectors
4	SFF drives (6.35 cm, 2.5 in)

* The serial number/iLO information pull tab is double-sided. The top side shows the server serial number, and the reverse side shows the default iLO account information. The same information is printed on a label attached to the chassis.

Front panel LEDs and buttons

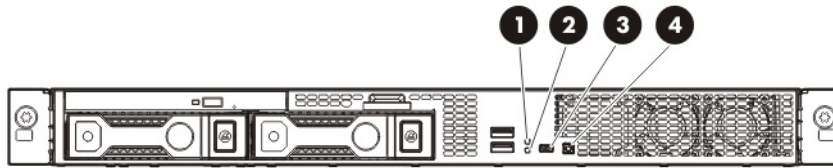

Item	Description	Status
1	Health LED	Solid green = Normal Flashing amber = System degraded Flashing red (1 Hz/cycle per sec) = System critical Fast-flashing red (4 Hz/cycles per sec) = Power fault*
2	NIC status LED	Solid green = Link to network Flashing green (1 Hz/cycle per sec) = Network active Off = No network activity
3	UID button/LED	Solid blue = Activated Flashing blue (1 Hz/cycle per sec) = Remote management or firmware upgrade in progress Off = Deactivated
4	Power On/Standby button and system power LED	Solid green = System on Flashing green (1 Hz/cycle per sec) = Performing power on sequence Solid amber = System in standby Off = No power present**

* To identify components in a degraded or critical state, see the iLO/BIOS logs and the server troubleshooting guide.
 ** Facility power is not present, power cord is not attached, no power supplies are installed, power supply failure has occurred, or the power button cable is disconnected.

Rear panel components

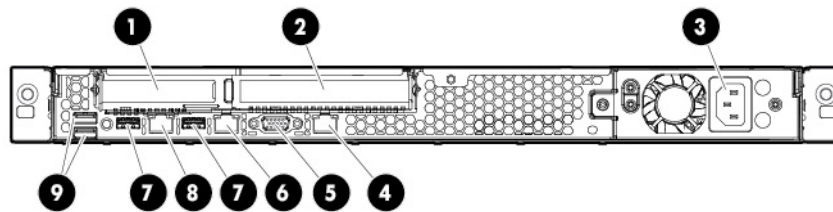

Item	Description
1	Slot 2 PCIe3 x8 (4, 1)
2	Slot 1 PCIe3 x16 (8, 4, 1)
3	Integrated power supply
4	NIC 1/shared iLO 4 connector
5	Video connector
6	NIC connector 2
7	USB 3.0 connectors
8	Dedicated iLO 4 connector
9	USB 2.0 connectors

Rear panel LEDs and buttons

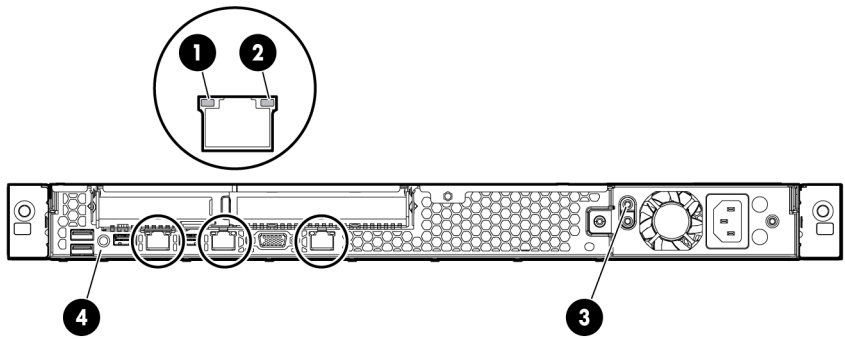

Item	Description	Status
1	NIC link LED	Solid green = Link exists Off = No link exists
2	NIC status LED	Solid green = Link to network Flashing green (1 Hz/cycle per sec) = Network active Off = No network activity
3	Power supply LED	Solid green = Normal Off = One or more of the following conditions exists: <ul style="list-style-type: none"> • Power is unavailable • Power supply failed • Power supply is in standby mode • Power supply error
4	UID button/LED	Solid blue = Activated Flashing blue (1 Hz/cycle per sec) = Remote management or firmware upgrade in progress Off = Deactivated

PCIe riser board slot definitions

The riser board slots transfer rate is the same for all supported processor models. Both slots will run in PCIe3 (8 GT/s) rate.

Slot number	Type	Length	Height	Connector link width	Negotiable link width
1	PCIe3	Half	Full	x16	x8
2	PCIe3	Half	Half	x8	x4

System board components

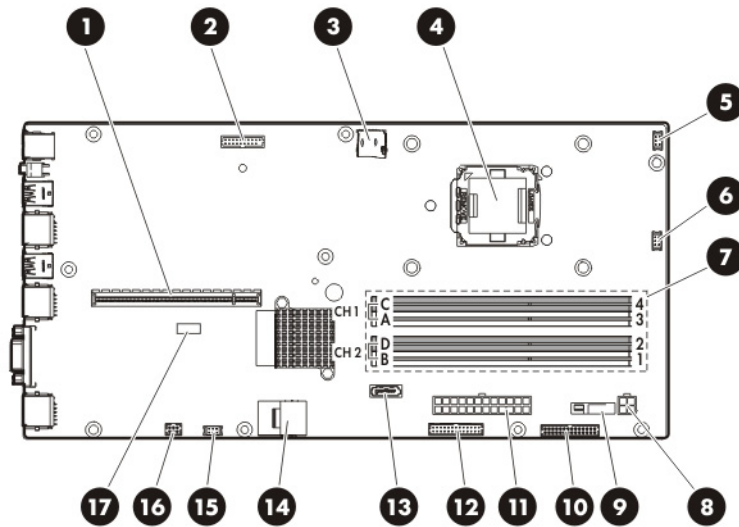

Item	Description
1	PCI riser connector*
2	TPM connector
3	microSD card slot
4	Processor socket
5	Fan connector 2
6	Fan connector 1
7	DIMM slots
8	4-pin power supply connector
9	System battery
10	Front I/O module connector
11	24-pin power supply connector
12	26-pin PDB connector
13	SATA connector
14	Mini-SAS connector
15	Fan connector 3
16	Internal USB 2.0 connector
17	System maintenance switch

* For more information on the riser board slots supported by the onboard PCI riser connector, see "PCIe riser board slot definitions (on page 77)."

DIMM slot locations

DIMM slots are numbered sequentially (1 through 4) for the processor. The supported AMP modes use the letter assignments for population guidelines.

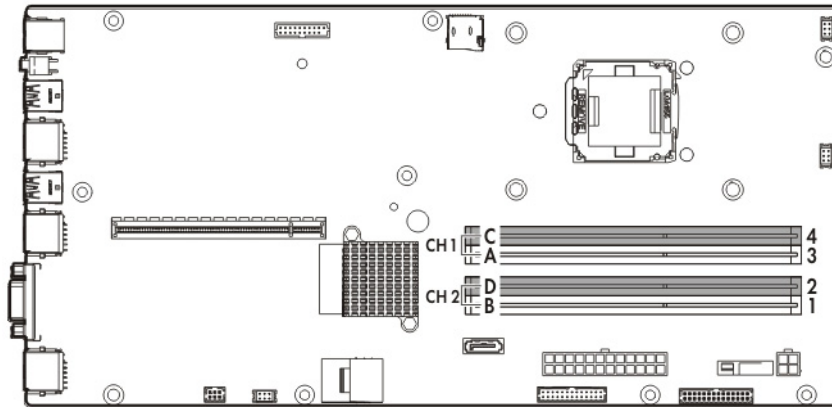

System maintenance switch

Position	Default	Function
S1	Off	Off = iLO 4 security is enabled. On = iLO 4 security is disabled.
S2	Off	Off = System configuration can be changed. On = System configuration is locked.
S3	Off	Reserved
S4	Off	Reserved
S5	Off	Off = Power-on password is enabled. On = Power-on password is disabled.
S6	Off	Off = No function On = ROM reads system configuration as invalid.
S7	—	Reserved
S8	—	Reserved
S9	—	Reserved
S10	—	Reserved
S11	—	Reserved
S12	—	Reserved

To access the redundant ROM, set S1, S5, and S6 to on.

When the system maintenance switch position 6 is set to the On position, the system is prepared to erase all system configuration settings from both CMOS and NVRAM.



CAUTION: Clearing CMOS and/or NVRAM deletes configuration information. Be sure to properly configure the server or data loss could occur.

NMI functionality

An NMI crash dump creates a crash dump log before resetting a system which is not responding.

Crash dump log analysis is an essential part of diagnosing reliability problems, such as failures of operating systems, device drivers, and applications. Many crashes freeze a system, and the only available action for administrators is to restart the system. Resetting the system erases any information which could support problem analysis, but the NMI feature preserves that information by performing a memory dump before a system reset.

To force the system to invoke the NMI handler and generate a crash dump log, do one of the following:

- Use the iLO Virtual NMI feature.
- Short the NMI header ("System board components" on page 78).

For more information, see the HP website (<http://www.hp.com/support/NMI>).

Drive numbering

- Two-bay LFF drive model

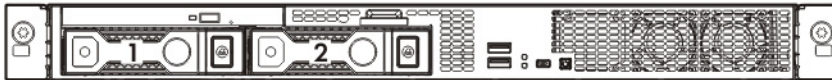

- Four-bay SFF drive model



Hot-plug drive LED definitions

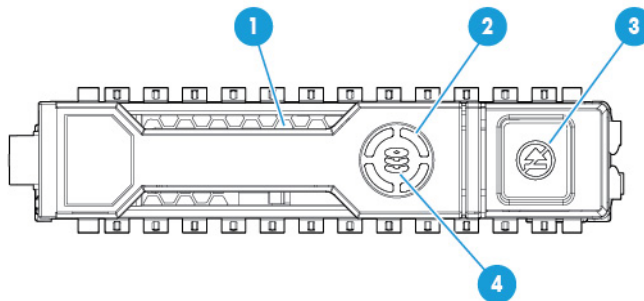

Item	LED	Status	Definition
1	Locate	Solid blue	The drive is being identified by a host application.
		Flashing blue	The drive carrier firmware is being updated or requires an update.
2	Activity ring	Rotating green	Drive activity
		Off	No drive activity
3	Do not remove	Solid white	Do not remove the drive. Removing the drive causes one or more of the logical drives to fail.

Item	LED	Status	Definition
		Off	Removing the drive does not cause a logical drive to fail.
4	Drive status	Solid green	The drive is a member of one or more logical drives.
		Flashing green	The drive is rebuilding or performing a RAID migration, strip size migration, capacity expansion, or logical drive extension, or is erasing.
		Flashing amber/green	The drive is a member of one or more logical drives and predicts the drive will fail.
		Flashing amber	The drive is not configured and predicts the drive will fail.
		Solid amber	The drive has failed.
		Off	The drive is not configured by a RAID controller.

FBWC module LED definitions

The FBWC module has three single-color LEDs (one amber and two green). The LEDs are duplicated on the reverse side of the cache module to facilitate status viewing.

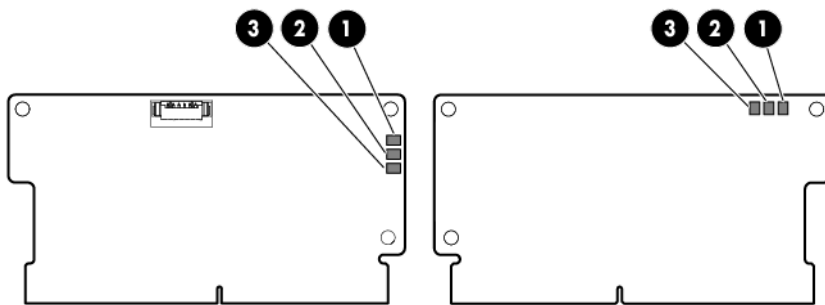

1 - Amber	2 - Green	3 - Green	Interpretation
Off	Off	Off	The cache module is not powered.
Off	Flashing 0.5 Hz	Flashing 0.5 Hz	The cache microcontroller is executing from within its boot loader and receiving new flash code from the host controller.
Off	Flashing 1 Hz	Flashing 1 Hz	The cache module is powering up, and the capacitor pack is charging.
Off	Off	Flashing 1 Hz	The cache module is idle, and the capacitor pack is charging.
Off	Off	On	The cache module is idle, and the capacitor pack is charged.
Off	On	On	The cache module is idle, the capacitor pack is charged, and the cache contains data that has not yet been written to the drives.
Off	Flashing 1 Hz	Off	A backup is in progress.
Off	On	Off	The current backup is complete with no errors.
Flashing 1 Hz	Flashing 1 Hz	Off	The current backup failed, and data has been lost.

1 - Amber	2 - Green	3 - Green	Interpretation
Flashing 1 Hz	Flashing 1 Hz	On	A power error occurred during the previous or current boot. Data may be corrupt.
Flashing 1 Hz	On	Off	An overtemperature condition exists.
Flashing 2 Hz	Flashing 2 Hz	Off	The capacitor pack is not attached.
Flashing 2 Hz	Flashing 2 Hz	On	The capacitor has been charging for 10 minutes, but has not reached sufficient charge to perform a full backup.
On	On	Off	The current backup is complete, but power fluctuations occurred during the backup.
On	On	On	The cache module microcontroller has failed.

Fan locations

The server has three system fans: two in the front of the chassis and one in the middle section. The server does not support redundant fans; all three fans are required to boot the server.

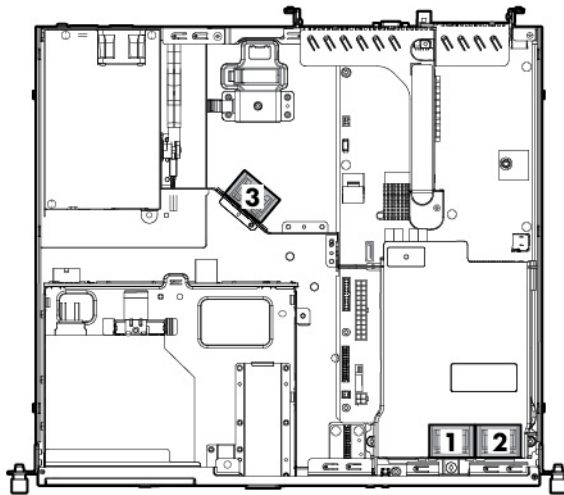

Cabling

Cabling overview

This section provides guidelines that help you make informed decisions about cabling the server and hardware options to optimize performance.

For information on cabling peripheral components, refer to the white paper on high-density deployment at the HP website (<http://www.hp.com/products/servers/platforms>).

CAUTION: When routing cables, always be sure that the cables are not in a position where they can be pinched or crimped.

Storage cabling

The FBWC capacitor pack cabling is shown in the following images. The FBWC solution is a separately purchased option. Capacitor pack cabling is only supported in Smart Array controller options that support FBWC installation ("Flash-backed write cache procedures" on page 54).

Two-bay LFF non-hot-plug drive cage cabling

- Mini-SAS cable connected to the system board

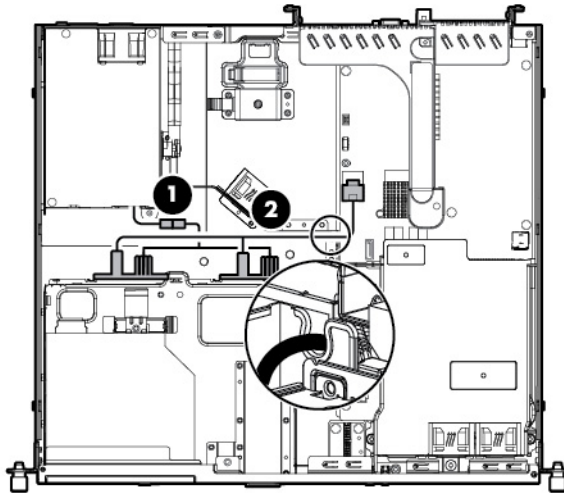

Item	Description
1	Power cable
2	Mini-SAS cable

- Mini-SAS cable connected to a storage controller in the full-height expansion slot

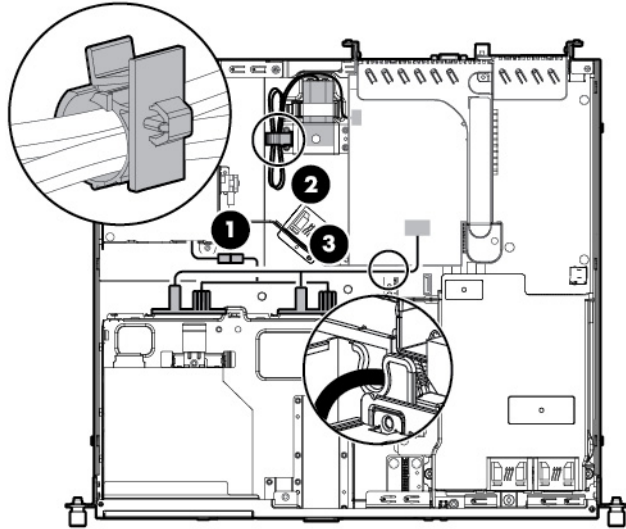

Item	Description
1	Power cable
2	Capacitor pack cable
3	Mini-SAS cable

Two-bay LFF hot-plug drive cage cabling

- Mini-SAS cable connected to the system board

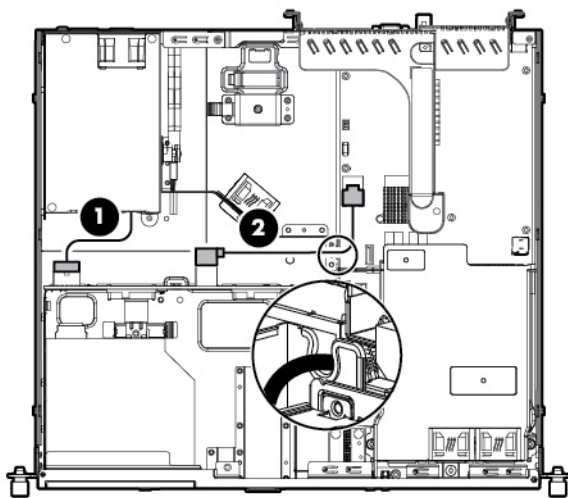

Item	Description
1	Power cable
2	Mini-SAS cable

- Mini-SAS cable connected to a storage controller in the full-height expansion slot

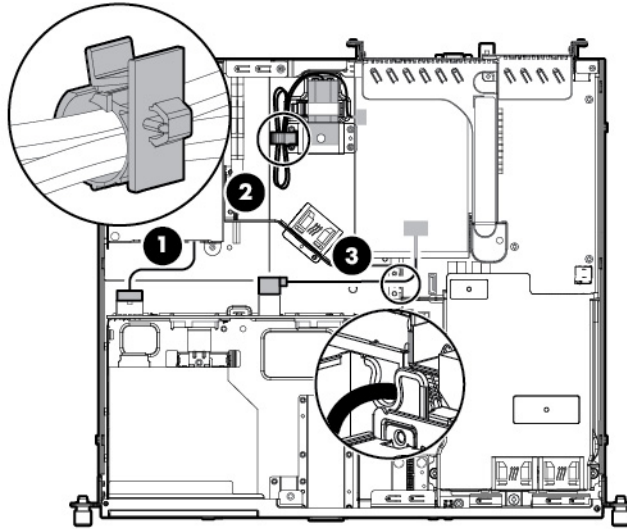

Item	Description
1	Power cable
2	Capacitor pack cable
3	Mini-SAS cable

Four-bay SFF hot-plug drive cage cabling (AC power supply)

The HP 250 W Integrated Power Supply and HP 300 W Integrated Power Supply is used in the following drive configurations:

- Mini-SAS cable connected to the system board

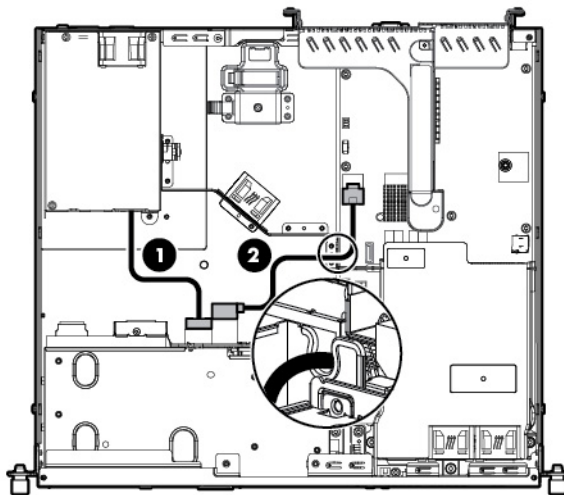

Item	Description
1	Power cable
2	Mini-SAS cable

- Mini-SAS cable connected to a storage controller in the full-height expansion slot

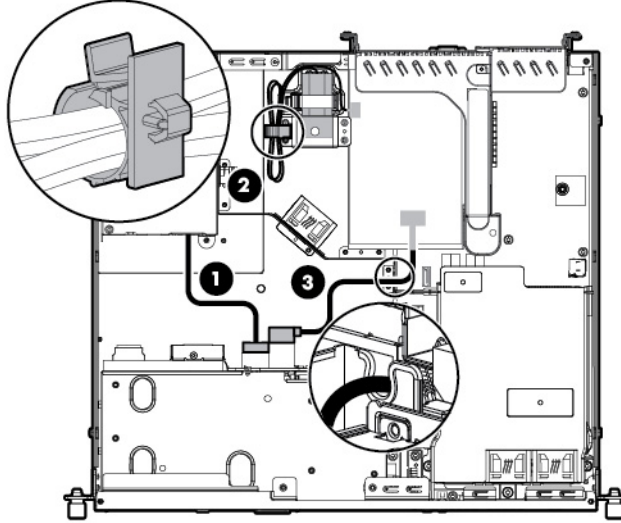

Item	Description
1	Power cable
2	Capacitor pack cable
3	Mini-SAS cable

The HP 750 W CS -48 V DC Power Supply (94% efficiency) with PDB is used in the following drive configurations:

- Mini-SAS cable connected to the system board

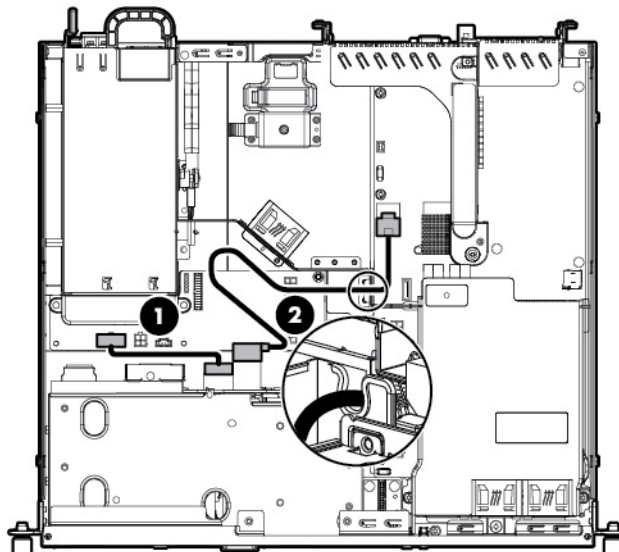

Item	Description
1	Power cable
2	Mini-SAS cable

- Mini-SAS cable connected to a storage controller in the full-height expansion slot

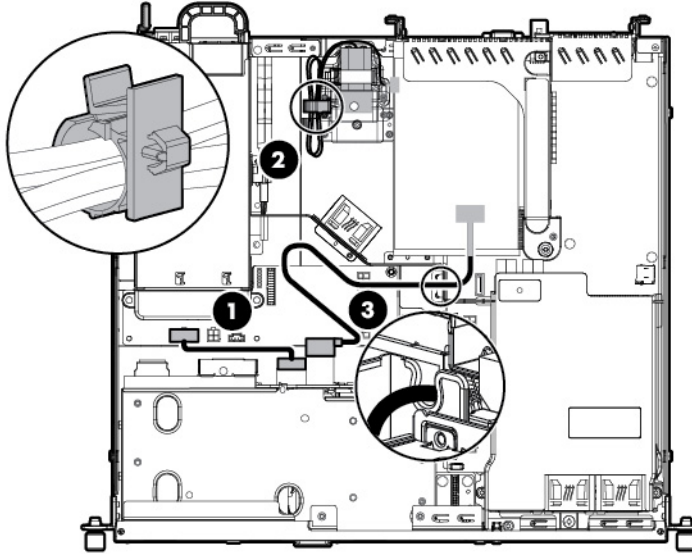

Item	Description
1	Power cable
2	Capacitor pack cable
3	Mini-SAS cable

Optical drive cabling

- Two-bay LFF drive model (uses the HP 250 W Integrated Power Supply or HP 300 W Integrated Power Supply)

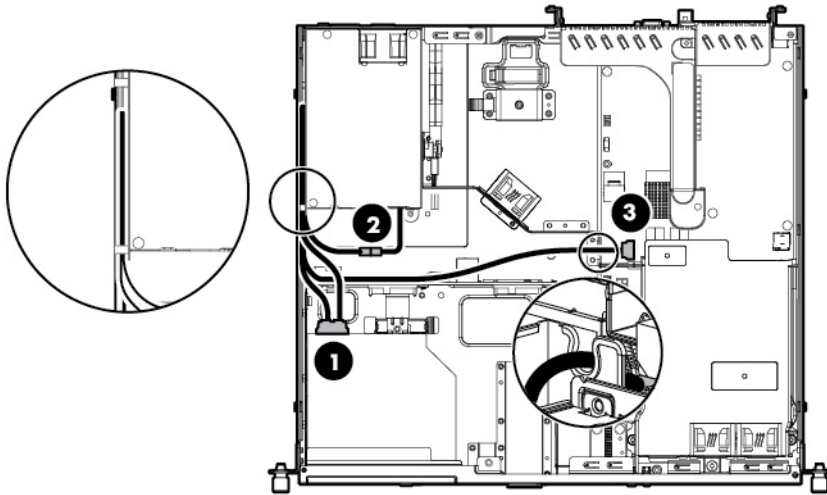

Item	Description
1	Common end of the optical drive SATA Y-cable
2	4-pin power connector of the optical drive SATA Y-cable
3	SATA connector of the optical drive SATA Y-cable

- Four-bay SFF drive model (uses the HP 750 W CS -48 V DC Power Supply)

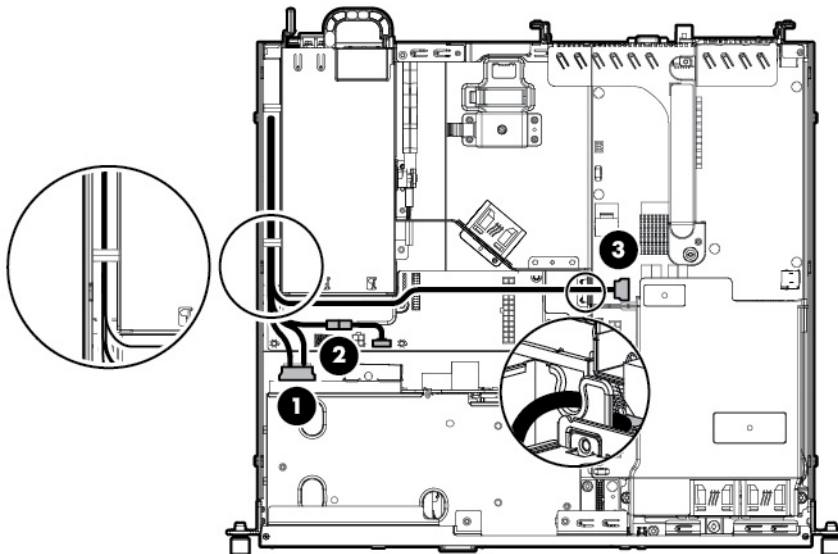

Item	Description
1	Common end of the optical drive SATA Y-cable
2	4-pin power connector of the optical drive SATA Y-cable

Item	Description
3	SATA connector of the optical drive SATA Y-cable

Power supply cabling

HP 250 W Integrated Power Supply cabling

- HP 250 W Integrated Power Supply cabling in a two-bay, LFF, non-hot-plug drive model

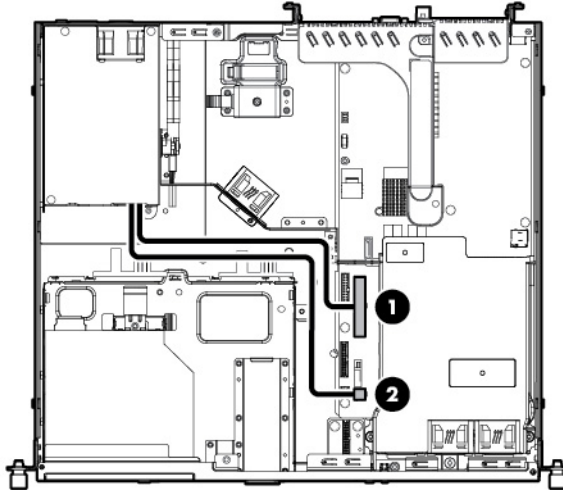

Item	Description
1	24-pin system board power cable
2	4-pin system board power cable

- HP 250 W Integrated Power Supply cabling in a two-bay, LFF, hot-plug drive model

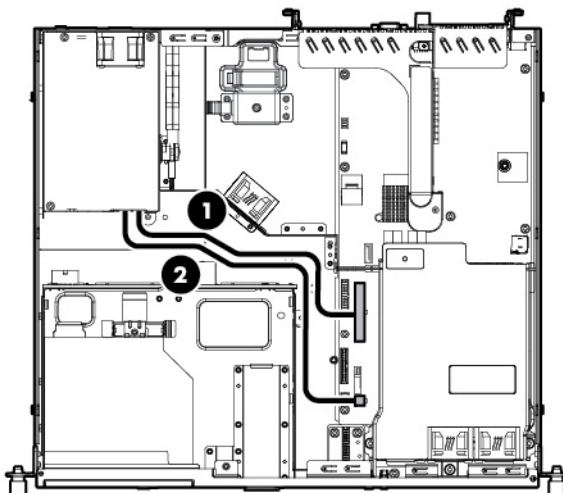

Item	Description
1	24-pin system board power cable
2	4-pin system board power cable

- HP 250 W Integrated Power Supply cabling in a four-bay, SFF, hot-plug drive model

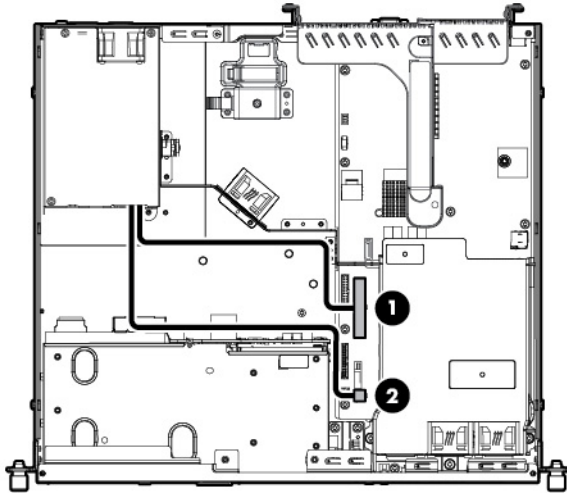

Item	Description
1	24-pin system board power cable
2	4-pin system board power cable

HP 300 W Integrated Power Supply cabling

- HP 300 W Integrated Power Supply cabling in a two-bay LFF non-hot-plug drive model

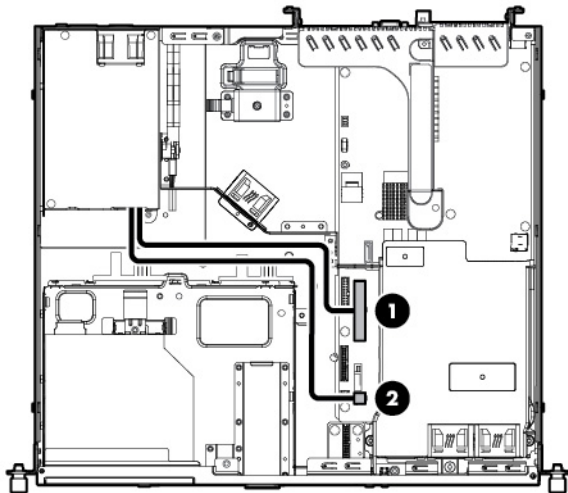

Item	Description
1	24-pin system board power cable
2	4-pin system board power cable

- HP 300 W Integrated Power Supply cabling in a two-bay LFF hot-plug drive model

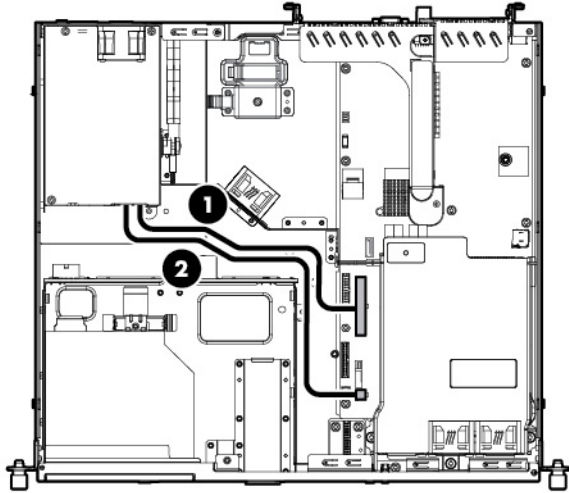

Item	Description
1	24-pin system board power cable
2	4-pin system board power cable

- HP 300 W Integrated Power Supply cabling in a four-bay SFF hot-plug drive model

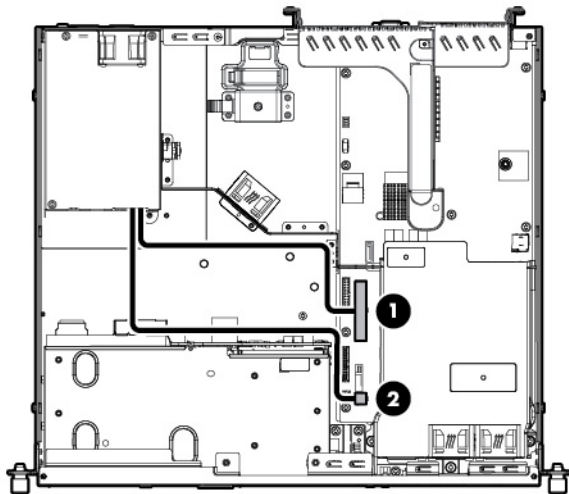

Item	Description
1	24-pin system board power cable
2	4-pin system board power cable

HP 750 W CS -48 V DC Power Supply (with PDB) cabling

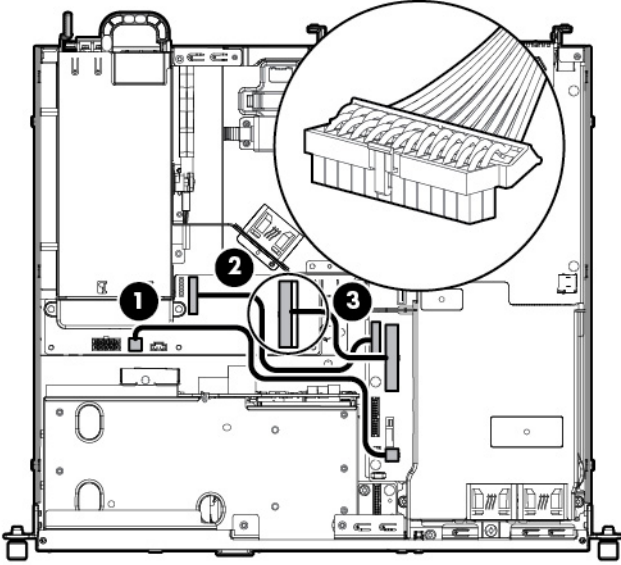

Item	Description
1	4-pin system board power cable
2	26-pin PDB cable
3	24-pin system board power cable

Internal USB cabling

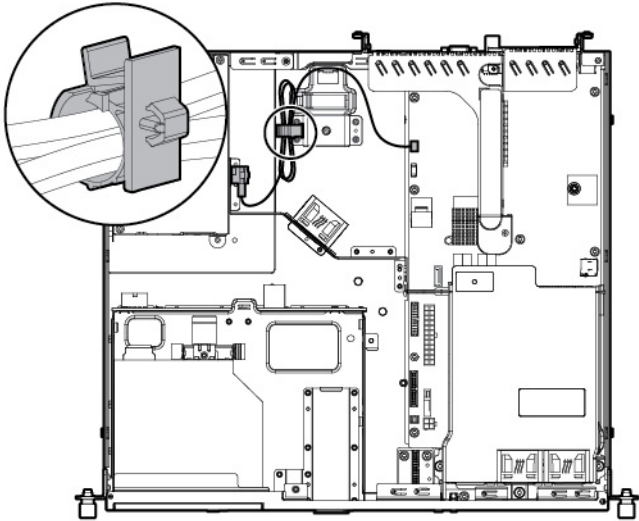

Front I/O board cabling

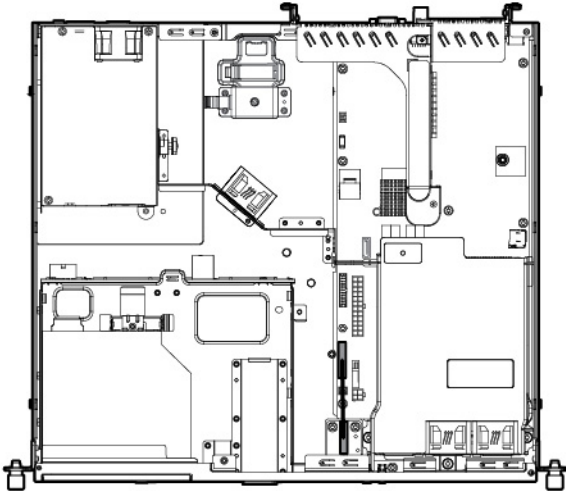

Specifications

Environmental specifications

Specification	Value
Temperature range*	
Operating	10°C to 35°C (50°F to 95°F)
Non-operating	-30°C to 60°C (-22°F to 140°F)
Relative humidity (non-condensing)	
Operating, maximum wet bulb temperature of 28°C (82.4°F)	10% to 90%
Non-operating, maximum wet bulb temperature of 38.7°C (101.7°F)	5% to 95%

* All temperature ratings shown are for sea level. An altitude derating of 1°C per 304.8 m (1.8°F per 1,000 ft) to 3048 m (10,000 ft) is applicable. No direct sunlight allowed.

Server specifications

Specification	Value
Height	4.32 cm (1.70 in)
Depth	38.30 cm (15.07 in)
Width	43.46 cm (17.11 in)
Weight (approximate range)	7.00 kg to 8.00 kg (15.43 lb to 17.64 lb)

Power supply specifications

Depending on installed options, the server is configured with one of the following power supplies:

- HP 250 W Integrated Power Supply
- HP 300 W Integrated Power Supply
- HP 750 W CS -48 V DC Power Supply (94% efficiency)

HP 250 W Integrated Power Supply

Specification	Value
Input requirements	—
Rated input voltage	100 V AC to 240 V AC
Rated input frequency	50 Hz–60 Hz
Rated input current	3 A to 6 A

Rated input power	312 W; 1,066 Btu/hr
Power supply output	—
Efficiency	80%
Maximum peak power	250 W

HP 300 W Integrated Power Supply

Specification	Value
Input requirements	—
Rated input voltage	100 V AC to 127 V AC 200 V AC to 240 V AC
Rated input frequency	50 Hz–60 Hz
Rated input current	6 A max at 100 V AC 3 A max at 200 V AC
Rated input power	600 W
Power supply output	—
Efficiency	80%
Maximum peak power	350 W (duration less 10 sec at 25°C)

HP 750 W CS -48 V DC Power Supply (94% efficiency)

Specification	Value
Input requirements	—
Rated input voltage	-36 V DC to -72 V DC -48 V DC nominal input
Rated input current	23 A at -36 V DC input 17 A at -48 V DC input, nominal input 11 A at -72 V DC input
Rated input power (W)	815 W at -36 V DC input 805 W at -48 V DC input, nominal input 795 W at -72 V DC input
Rated input power (Btus per hour)	2780 at -36 V DC input 2740 at -48 V DC input, nominal input 2720 at -72 V DC input
Power supply output	—
Rated steady-state power (W)	750 W
Maximum peak power (W)	750 W



CAUTION: This equipment is designed to permit the connection of the earthed conductor of the DC supply circuit to the earthing conductor at the equipment. If this connection is made, all of the following must be met:

- This equipment must be connected directly to the DC supply system earthing electrode conductor or to a bonding jumper from an earthing terminal bar or bus to which the DC supply system earthing electrode conductor is connected.

-
- This equipment must be located in the same immediate area (such as adjacent cabinets) as any other equipment that has a connection between the earthed conductor of the same DC supply circuit and the earthing conductor, and also the point of earthing of the DC system. The DC system must be earthed elsewhere.
 - The DC supply source is to be located within the same premises as the equipment.
 - Switching or disconnecting devices must not be in the earthed circuit conductor between the DC source and the point of connection of the earthing electrode conductor.
-



WARNING: To reduce the risk of electric shock, energy hazards, fire, and damage to the equipment, you must install this product in accordance with the following guidelines:

- This equipment must be installed by trained service personnel, as defined by the NEC and IEC 60950-1, Second Edition, the standard for Safety of Information Technology Equipment.
 - This power supply is intended only for installation in HP servers located in a restricted access location.
 - In accordance with applicable national requirements for Information Technology Equipment and Telecommunications Equipment, this power supply only connects to DC power sources that are classified as SELV or TNV. Generally, these requirements are based on the International Standard for Information Technology Equipment, IEC 60950-1. In accordance with local and regional electric codes and regulations, the DC source must have one pole (Neutral/Return) reliably connected to earth ground.
 - This power supply is not intended for direct connection to the DC supply branch circuit. Connect this power supply to a power distribution unit (PDU) that provides an independent overcurrent-protected output for each DC power supply.
 - The branch circuit overcurrent protection must be rated 24 A.
 - You must connect the power supply ground screw located on the front of the power supply to a suitable ground (earth) terminal. In accordance with local and regional electric codes and regulations, this terminal must be connected to a suitable building ground (earth) terminal. Do not rely on the rack or cabinet chassis to provide adequate ground (earth) continuity.
-

Acronyms and abbreviations

ABEND

abnormal end

AMP

Advanced Memory Protection

ASR

Automatic Server Recovery

CSR

Customer Self Repair

DDR3

double data rate-3

EM

enterprise mainstream (HP SSD endurance class)

FBWC

flash-backed write cache

HP CS

HP Common Slot (power supply)

HP SIM

HP Systems Insight Manager

IEC

International Electrotechnical Commission

iLO

Integrated Lights-Out

IML

Integrated Management Log

LFF

large form factor

LRDIMM

load reduced dual in-line memory module

MDL

midline (HP Midline drive family)

MLC

multilevel cell (NAND memory type used in SSDs)

NAND

Not AND

NMI

nonmaskable interrupt

NVRAM

nonvolatile memory

PCIe

Peripheral Component Interconnect Express

PDB

power distribution board

PDU

power distribution unit

POST

Power-On Self Test

RBSU

ROM-Based Setup Utility

RDIMM

registered dual in-line memory module

SAS

serial attached SCSI

SATA

serial ATA

SD

Secure Digital

SELV

separated extra low voltage

SFF

small form factor

SPP

HP Service Pack for ProLiant

TNV

telephone network voltage

TPM

Trusted Platform Module

UDIMM

unregistered dual in-line memory module

UID

unit identification

USB

universal serial bus

Documentation feedback

HP is committed to providing documentation that meets your needs. To help us improve the documentation, send any errors, suggestions, or comments to Documentation Feedback (<mailto:docsfeedback@hp.com>). Include the document title and part number, version number, or the URL when submitting your feedback.

Index

A

access panel 35
air baffle 36
Automatic Server Recovery (ASR) 74

C

cabling, capacitor pack 83
cabling, drive 83, 84
cabling, front I/O 93
cabling, internal power 89
cabling, internal USB 92
cache module 54, 81
capacitor pack 55
capacitor pack cabling 83
Care Pack 72
center fan 58
clearing NVRAM 79
CMOS 79
components, front panel 75
components, mechanical 16
components, rear panel 76
components, system board 78
crash dump analysis 80
customer self repair (CSR) 6

D

DC power specifications 95
DC power supply 33
DC power supply enablement kit 62
diagnostic tools 72, 74
dimensions and weight 94
DIMM slot locations 79
DIMMs, removing 44
documentation feedback 100
drive blank 31
drive cabling 83
drive carrier 34
drive LEDs 80
drive numbering 80
drives, determining status of 80
drives, non-hot-plug 34

E

electrostatic discharge 25
environmental specifications 94
extending server from rack 29
external USB functionality 74

F

fan module location 82
FBWC capacitor pack 55
FBWC module 54
FBWC module LEDs 81
flash-backed write cache procedures 54, 57
front I/O board 43
front I/O cabling 93
front panel buttons 76
front panel components 75
front panel LEDs 76

H

health driver 74
health LED 76
heatsink 45
hot-plug drive, removing 32
HP Insight Diagnostics 72
HP Insight Diagnostics survey functionality 72
HP Insight Remote Support software 72
HP technical support 6
humidity 94

I

illustrated parts catalog 16
iLO connector 76
Integrated Lights-Out (iLO) 73
Integrated Management Log (IML) 73
Intelligent Provisioning 72
internal cables 83
internal USB cabling 92
internal USB connector 59
internal USB functionality 74

L

- LED, health 76
- LED, system power 76
- LEDs, drive 80
- LEDs, FBWC module 81
- LEDs, front panel 76, 80
- LEDs, NIC 76, 77
- LEDs, power supply 77
- LEDs, rear panel 77
- LEDs, unit identification (UID) 76, 77

M

- mechanical components 16
- memory dump 80
- microSD card slot 78
- Mini-SAS cable 38

N

- NIC connectors 76
- NMI functionality 80
- NMI header 78, 80
- non-hot-plug drive cable assembly 42
- non-hot-plug drives, removing 34

O

- operating system crash 74, 80
- operating systems supported 72
- optical drive 37

P

- part numbers 16
- PCI riser board expansion slot definitions 77
- PCI riser cage 51
- PCIe riser board 53
- POST error messages 71
- power distribution board (PDB) 62
- power supply 33, 61
- power supply cabling 89, 90, 92
- power supply cage 63
- power supply cover 60
- power supply LEDs 77
- power supply specifications 94, 95
- powering down 28
- power-on password 79
- preparation procedures 27
- processor 47

R

- rack mount ears 30
- rack rail cable ties 32
- rack warnings 27
- rack, extending server from 29
- rack, removing server from 30
- rear panel buttons 77
- rear panel components 76
- rear panel LEDs 77
- recovering the data from the cache 57
- re-entering the server serial number 64
- removal and replacement procedures 25
- removing server from rack 30
- required tools 25
- ROM-Based Setup Utility (RBSU) 73

S

- safety considerations 25
- SAS drives 16, 80
- SATA drives 16
- security bezel, removing 28
- serial number 75
- serial number/iLO information pull tab 75
- server specifications 94
- server warnings and cautions 26, 27
- spare part numbers 16
- specifications, environmental 94
- specifications, server 94
- static electricity 25
- symbols on equipment 25
- system board components 78
- system board replacement 64
- system components 75
- system configuration settings 79
- system maintenance switch 79

T

- technical support 6
- temperature requirements 94
- TPM connector 78
- troubleshooting resources 71
- Trusted Platform Module (TPM) 70

U

- UID button 76
- UID LED 76, 77
- unit identification (UID) 77
- USB connector 75, 76

USB support 73
utilities 72

V

video connector 77

W

warnings 26, 27
weight 94