

Dell PowerEdge FC430

Owner's Manual

Notes, cautions, and warnings

 **NOTE:** A NOTE indicates important information that helps you make better use of your product.

 **CAUTION:** A CAUTION indicates either potential damage to hardware or loss of data and tells you how to avoid the problem.

 **WARNING:** A WARNING indicates a potential for property damage, personal injury, or death.

© 2016 Dell Inc. All rights reserved. This product is protected by U.S. and international copyright and intellectual property laws. Dell and the Dell logo are trademarks of Dell Inc. in the United States and/or other jurisdictions. All other marks and names mentioned herein may be trademarks of their respective companies.

1 PowerEdge FC430 system overview.....	7
Supported configurations for FC430 system.....	7
Front panel.....	7
Front panel view—single SSD system.....	7
Front panel view—dual SSD system.....	8
Diagnostic indicators on the front panel.....	9
Health status indicator.....	9
SSD activity indicator codes.....	10
iDRAC Direct LED indicator codes.....	11
Locating Service Tag of your system.....	12
2 Documentation resources.....	13
3 Technical specifications.....	15
Chassis dimensions and weight.....	15
Processor specifications.....	15
System battery specification.....	15
Memory specifications.....	16
RAID controller.....	16
Drive specifications.....	16
SSD specification.....	16
Ports and connectors specifications	16
USB ports.....	16
QSFP+ port.....	16
PCIe Mezzanine card.....	16
Video specification.....	16
Environmental specifications.....	17
Particulate and gaseous contamination specifications	18
Standard operating temperature	19
Expanded operating temperature restrictions	19
4 Initial system setup and configuration.....	20
Setting up your system.....	20
iDRAC configuration.....	20
Options to set up iDRAC IP address.....	20
Options to install the operating system.....	21
Methods to download firmware and drivers.....	21
5 Pre-operating system management applications.....	23
Options to manage the pre-operating system applications.....	23
System Setup.....	23
Viewing System Setup.....	23

System Setup details.....	24
System BIOS.....	24
iDRAC Settings utility.....	43
Device Settings.....	44
Dell Lifecycle Controller.....	44
Embedded systems management.....	44
Boot Manager.....	45
Viewing Boot Manager.....	45
Boot Manager main menu.....	45
PXE boot.....	46
6 Installing and removing sled components.....	47
Safety instructions.....	47
Before working inside your system.....	47
After working inside your system.....	48
Recommended tools.....	48
Sled.....	48
Removing a sled.....	48
Installing a sled.....	49
Inside the sled.....	50
Cooling shroud.....	51
Removing the cooling shroud.....	51
Installing the cooling shroud.....	53
System memory.....	54
General memory module installation guidelines.....	55
Mode-specific guidelines.....	56
Sample memory configurations.....	58
Removing memory modules.....	59
Installing memory modules.....	61
PCIe mezzanine card.....	62
Removing the PCIe mezzanine card.....	63
Installing the PCIe mezzanine card.....	65
Internal Dual SD Module (IDSDM) card	66
Removing an internal SD card.....	67
Installing an internal SD card.....	68
Removing the IDSDM card.....	69
Installing the IDSDM card.....	71
SD vFlash card.....	72
Replacing the SD vFlash card.....	72
Installing the SD vFlash card.....	73
LAN on Motherboard (LOM) riser card.....	74
Removing the LOM riser card.....	74
Installing the LOM riser card.....	75
Processors.....	76
Removing a heat sink.....	77
Removing a processor.....	78

Installing a processor.....	82
Installing a heat sink.....	83
Processor blank and DIMM blank.....	84
Removing a processor blank and DIMM blank.....	85
Installing a processor blank and DIMM blank.....	86
Solid State Drives (SSD).....	86
SSD installation guidelines.....	86
Shutdown procedure for servicing an SSD.....	86
Removing an SSD from an SSD carrier	87
Installing an SSD into an SSD carrier.....	88
Removing an SSD carrier.....	89
Installing an SSD carrier.....	90
Removing an SSD blank.....	91
Installing an SSD blank.....	92
Removing the SSD cage.....	92
Installing the SSD cage.....	93
Configuring the boot drive.....	95
Solid State Drive (SSD) backplane.....	95
Removing the SSD backplane.....	95
Installing the SSD backplane.....	96
System battery.....	98
Replacing the NVRAM backup battery.....	98
System board.....	99
Removing the system board.....	99
Installing the system board.....	101
Restoring the Service Tag by using the Easy Restore feature.....	103
Entering the system Service Tag by using System Setup.....	103
Trusted Platform Module.....	104
Installing the Trusted Platform Module.....	104
Initializing the TPM for BitLocker users.....	105
Initializing the TPM for TXT users.....	105
7 Using system diagnostics.....	106
Dell Embedded System Diagnostics.....	106
When to use the Embedded System Diagnostics.....	106
Running the Embedded System Diagnostics.....	106
System diagnostics controls.....	107
8 Jumpers and connectors	108
System board jumper settings.....	108
System board connectors.....	109
Disabling a forgotten password.....	110
9 Troubleshooting your system.....	111
Safety first — for you and your system.....	111
Troubleshooting system memory.....	111

Troubleshooting Solid State Drives.....	112
Troubleshooting USB devices.....	112
Troubleshooting an internal SD card.....	113
Troubleshooting processors.....	113
Troubleshooting the system board.....	114
Troubleshooting the NVRAM backup battery.....	114
10 Getting help.....	116
Contacting Dell.....	116
Quick Resource Locator.....	116

PowerEdge FC430 system overview

The Dell PowerEdge FC430 system is a quarter-width sled that supports up to:

- Two Intel Xeon E5-2600 v4 processors
- Eight DIMMs
- Two 1.8-inch uSATA solid state drives (SSDs).

Topics:

- [Supported configurations for FC430 system](#)
- [Front panel](#)
- [Diagnostic indicators on the front panel](#)
- [Locating Service Tag of your system](#)

Supported configurations for FC430 system

The Dell PowerEdge FC430 system supports the following configurations:

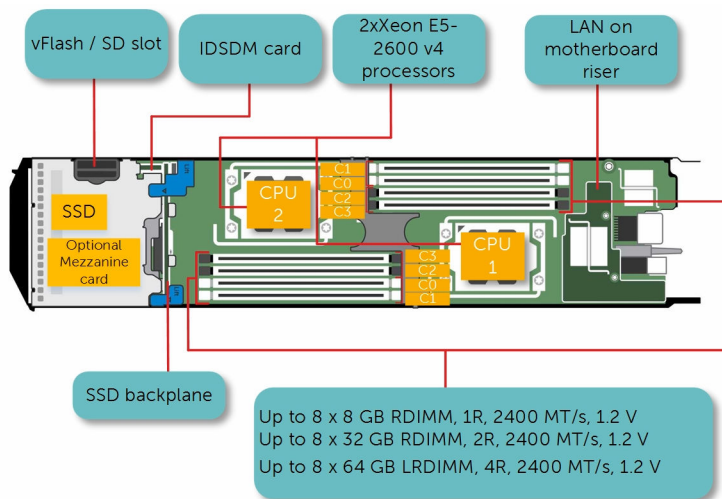

Figure 1. Supported configurations for the Dell PowerEdge FC430 system

Front panel

The front panel provides access to the features available on the front of the server, such as the power button, status indicator, management indicator, and USB ports. The diagnostic LEDs or the LCD panel is prominently located on the front panel. The hot-swappable hard drives are accessible from the front panel.

Front panel view—single SSD system

The following figure and the table describe the single SSD system features and its indicators.

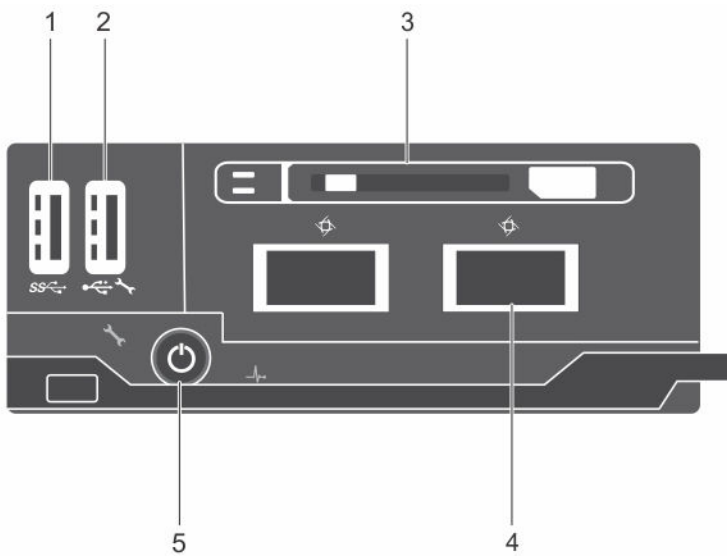





Figure 2. Front panel view—single SSD system

- | | | | |
|---|---------------------------------------|---|--|
| 1 | USB port | 2 | USB management port or iDRAC Direct port |
| 3 | SSD | 4 | QSFP+ connector |
| 5 | Sled power-on indicator, power button | | |

Table 1. Front panel features and indicators—single SSD system

Item	Indicator, button, or connector	Icon	Description
1	USB connector		Enables you to connect USB devices to the sled. This port is USB 3.0 compliant.
2	USB management port or iDRAC Direct port		Enables you to connect USB devices to the sled or provides access to the iDRAC Direct features. For more information about iDRAC, see the iDRAC Guide at Dell.com/idracmanuals . This port is USB 2.0 compliant.
3	SSD		A single 1.8-inch hot-swappable uSATA SSD is supported in this chassis.
4	QSFP+ connector (2)		The QSFP+ connectors can be used for Infiniband or for Ethernet.
5	Sled power-on indicator, power button		The power-on indicator turns on when the sled is turned on. The power button controls the power supply output to the system.

Front panel view—dual SSD system

The following figure and the table describes about the dual SSD system features and its indicators.

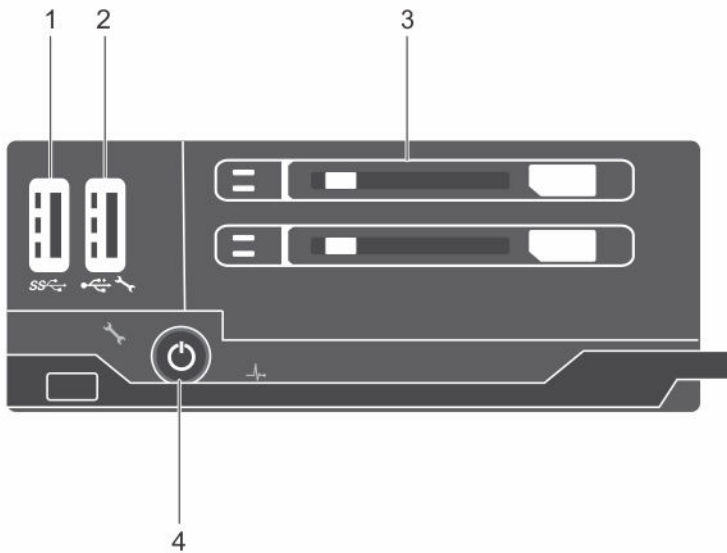





Figure 3. Front panel view—dual SSD system

- | | | | |
|---|----------|---|--|
| 1 | USB port | 2 | USB management port or iDRAC Direct port |
| 3 | SSD | 4 | Sled power-on indicator, power button |

Table 2. Front panel features and indicators—dual SSD system

Item	Indicator, button, or connector	Icon	Description
1	USB port		Enables you to connect USB devices to the sled. This port is USB 3.0 compliant.
2	USB management port or iDRAC Direct port		Enables you to connect USB devices to the sled or provides access to the iDRAC Direct features. For more information about iDRAC, see the iDRAC Guide at Dell.com/idracmanuals . This port is USB 2.0 compliant.
3	SSD (2)		Up to two 1.8-inch hot-swappable uSATA SSDs are supported in this chassis.
4	Sled power-on indicator, power button		The power-on indicator turns on when the sled is turned on. The power button controls the power supply output to the system.

Diagnostic indicators on the front panel

Health status indicator

The Health status indicator indicates the health condition of the system.

Table 3. Health status indicator codes

Icon	Health-status indicator pattern	Condition
	Solid blue	No errors are present in the system. System is in good health.
	Blinking blue	Identify mode is enabled (regardless of system errors)—system is in the process of identifying the sled.
	Solid amber	System is in failsafe mode—sled is not ready/available and the chassis cannot be turned on.
	Flashes amber	Errors present in the system.

SSD activity indicator codes

The Solid State Drive (SSD) indicators display different patterns as drive events occur in the system.

NOTE: The sled must have an SSD or an SSD blank installed in each drive bay.



Figure 4. SSD indicators

- 1 SSD activity indicator (green)
- 2 SSD status indicator (green and amber)

NOTE: If the drive is in the Advanced Host Controller Interface (AHCI) mode, the status LED (on the right side) does not function and remains off.

Table 4. SSD indicator codes

Drive-Status indicator pattern	Condition
Flashes green twice per second	Identifying the drive or preparing for removal
Off	Drive ready for insertion or removal

Drive-Status indicator pattern

Condition

Drive-Status indicator pattern	Condition
	NOTE: The drive status indicator remains off until all drives are initialized after system power is supplied. Drives are not ready for insertion or removal during this time.
Flashes green, amber, and then turns off	Predicted drive failure
Flashes amber four times per second	Drive failed
Flashes green slowly	Drive rebuilding
Steady green	Drive online
Flashes green for three seconds, amber for three seconds, and turns off after six seconds	Rebuild aborted

iDRAC Direct LED indicator codes

The iDRAC Direct LED indicator lights up to indicate that the port is connected and is being used as a part of the iDRAC subsystem.

NOTE: The iDRAC Direct LED indicator does not turn on when the USB port is used in the USB mode.

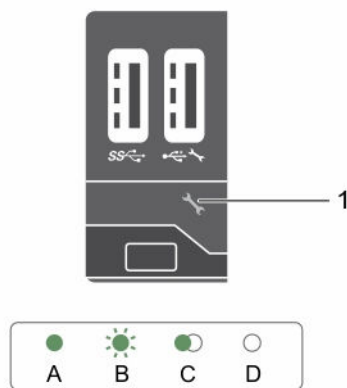

Figure 5. iDRAC Direct LED indicator

1 iDRAC Direct status indicator

The iDRAC Direct LED indicator table describes iDRAC Direct activity when configuring iDRAC Direct by using the management port (USB XML Import).

Table 5. iDRAC Direct LED indicators

Convention	iDRAC Direct LED indicator pattern	Condition
A	Green	Turns green for a minimum of two seconds to indicate the start and end of a file transfer.
B	Flashing green	Indicates file transfer or any operation tasks.
C	Green and turns off	Indicates that the file transfer is complete.
D	Not lit	Indicates that the USB is ready to be removed or that a task is complete.

The following table describes iDRAC Direct activity when configuring iDRAC Direct by using your laptop and cable (Laptop Connect):

Table 6. iDRAC Direct LED indicator patterns

iDRAC Direct LED indicator pattern	Condition
Solid green for two seconds	Indicates that the laptop is connected.
Flashing green (on for two seconds and off for two seconds)	Indicates that the laptop connected is recognized.
Turns off	Indicates that the laptop is unplugged.

Locating Service Tag of your system

Your system is identified by a unique Express Service Code and Service Tag number. The Express Service Code and Service Tag are found on the front of the system by pulling out the information tag. Alternatively, the information may be on a sticker on the chassis of the system. This information is used by Dell to route support calls to the appropriate personnel.

Documentation resources

This section provides information about the documentation resources for your system.

Table 7. Additional documentation resources for your system

Task	Document	Location
Setting up your system	For information about installing the system into a rack, see the Rack documentation included with your rack solution.	Dell.com/poweredgemanuals
	For information about turning on the system and the technical specifications of your system, see the <i>Getting Started With Your System</i> document that is shipped with your system.	Dell.com/poweredgemanuals
Configuring your system	For information about iDRAC features, configuring and logging in to iDRAC, and managing your system remotely, see the Integrated Dell Remote Access Controller User's Guide.	Dell.com/idracmanuals
	For information about installing the operating system, see the operating system documentation.	Dell.com/operatingsystemmanuals
	For information about understanding Remote Access Controller Admin (RACADM) subcommands and supported RACADM interfaces, see the RACADM Command Line Reference Guide for iDRAC.	Dell.com/idracmanuals
	For information about updating drivers and firmware, see the Methods to download firmware and drivers section in this document.	Dell.com/support/drivers
Managing your system	For information about systems management software offered by Dell, see the Dell OpenManage Systems Management Overview Guide.	Dell.com/openmanagemanuals
	For information about setting up, using, and troubleshooting OpenManage, see the Dell OpenManage Server Administrator User's Guide.	Dell.com/openmanagemanuals
	For information about installing, using, and troubleshooting Dell OpenManage Essentials, see the Dell OpenManage Essentials User's Guide.	Dell.com/openmanagemanuals
	For information about installing and using Dell System E-Support Tool (DSET), see the Dell System E-Support Tool (DSET) User's Guide.	Dell.com/DSET
	For information about installing and using Active System Manager (ASM), see the Active System Manager User's Guide.	Dell.com/asmdocs

Task	Document	Location
	For understanding the features of Dell Lifecycle Controller (LCC), see the Dell Lifecycle Controller User's Guide.	Dell.com/idracmanuals
	For information about partner programs enterprise systems management, see the OpenManage Connections Enterprise Systems Management documents.	Dell.com/omconnectionsenterprisesystemsmanagement
	For information about connections and client systems management, see the OpenManage Connections Client Systems Management documentation.	Dell.com/dellclientcommandsuitemanuals
	For information about viewing inventory, performing configuration and monitoring tasks, remotely turning on or off servers, and enabling alerts for events on servers and components using the Dell Chassis Management Controller (CMC), see the CMC User's Guide.	Dell.com/esmmanuals
Working with Dell PowerEdge RAID controllers	For information about understanding the features of the Dell PowerEdge RAID controllers (PERC) and deploying the PERC cards, see the Storage controller documentation.	Dell.com/storagecontrollermanuals
Understanding event and error messages	For information about checking the event and error messages generated by the system firmware and agents that monitor system components, see the Dell Event and Error Messages Reference Guide.	Dell.com/openmanagemanuals > OpenManage software

Technical specifications

The technical and environmental specifications of your system are outlined in this section.

Chassis dimensions and weight

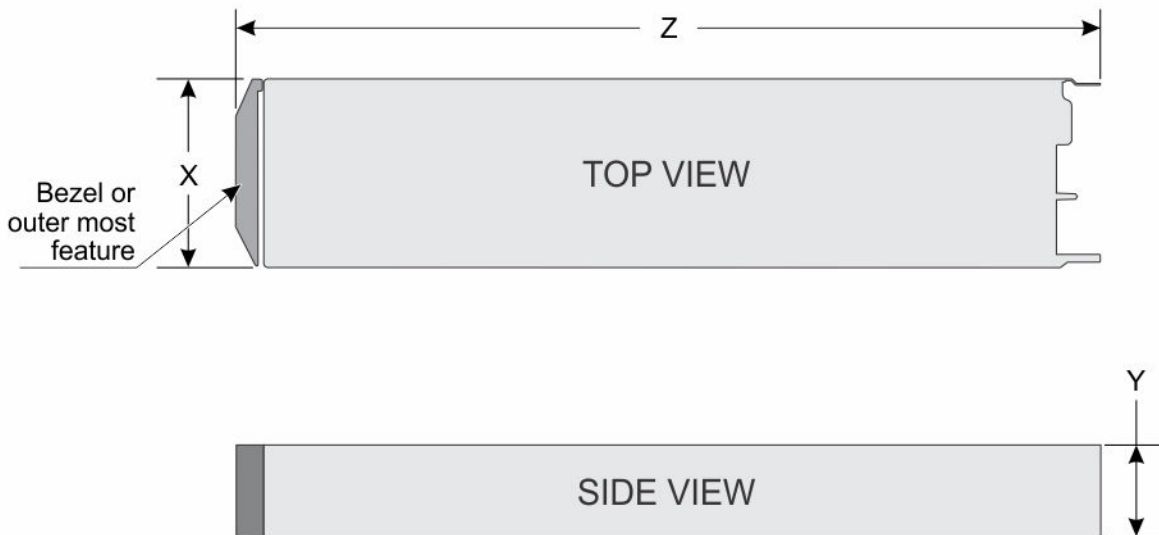

Figure 6. Chassis dimensions of the PowerEdge FC430 system

Table 8. Dimensions of the PowerEdge FC430 system

System	X	Y	Z
FC430	102.7 mm	40.3 mm	480.36 mm

Table 9. Chassis weight

System	Chassis weight
FC430	3.0 kg (6.61 lb)

Processor specifications

The PowerEdge FC430 system supports up to two Intel Xeon E5-2600 v4 processors.

System battery specification

The PowerEdge FC430 system supports CR 2032 3.0-V lithium coin cell system battery.

Memory specifications

The PowerEdge FC430 system supports DDR4 registered DIMMs (RDIMMs and LRDIMMs).

Table 10. Memory specifications

Memory module sockets	Memory capacity	Minimum RAM	Maximum RAM
Eight 288-pin	4 GB, 8 GB, 16 GB, and 32 GB (RDIMMs)	4 GB (RDIMM)	256 GB (RDIMM)
	64 GB (LRDIMM)	64 GB (LRDIMM)	512 GB (LRDIMM)

RAID controller

The PowerEdge FC430 system supports PERC S130 controller.

Drive specifications

SSD specification

The PowerEdge FC430 system supports up to two 1.8-inch uSATA SSDs.

Ports and connectors specifications

USB ports

The PowerEdge FC430 system supports:

- One 4-pin, USB 3.0 compliant port
- USB management port or iDRAC Direct port which supports USB 2.0 compliant port

QSFP+ port

The QSFP+ port is used for Infiniband or Ethernet.

PCIe Mezzanine card

The PowerEdge FC430 system supports one PCIe x8 mezzanine slot supporting a single or dual port InfiniBand mezzanine card.

Video specification

The PowerEdge FC430 supports Matrox G200eR2 video controller. The available memory is 16 MB which is shared with the iDRAC application memory.

Environmental specifications

NOTE: For additional information about environmental measurements for specific system configurations, see [Dell.com/environmental_datasheets](https://www.dell.com/environmental_datasheets).

Table 11. Temperature specifications

Temperature	Specifications
Storage	–40°C to 65°C (–40°F to 149°F)
Continuous operation (for altitude less than 950 m or 3117 ft)	10°C to 35°C (50°F to 95°F) with no direct sunlight on the equipment
Maximum temperature gradient (operating and storage)	20°C/h (36°F/h)

Table 12. Relative humidity specifications

Relative humidity	Specifications
Storage	5% to 95% RH with 33°C (91°F) maximum dew point. Atmosphere must be non-condensing at all times.
Operating	10% to 80% RH with 29°C (84.2°F) maximum dew point.

Table 13. Maximum vibration specifications

Maximum vibration	Specifications
Operating	0.26 G _{rms} at 5 Hz to 350 Hz (all operation orientations)
Storage	1.87 G _{rms} at 10 Hz to 500 Hz for 15 minutes (all six sides tested)

Table 14. Maximum shock pulse specifications

Maximum shock pulse	Specifications
Operating	One shock pulse in the positive z axes of 31 G for 2.6 ms in all operational orientations.
Storage	Six consecutively executed shock pulses in the positive and negative x, y, and z axes (one pulse on each side of the system) of 71 G for up to 2 ms.

Table 15. Maximum altitude specifications

Maximum altitude	Specifications
Operating	3048 m (10,000 ft)
Storage	12,000 m (39,370 ft)

Table 16. Operating temperature de-rating specification

Operating temperature de-rating	Specifications
Up to 35°C (95°F)	Maximum temperature is reduced by 1°C/300 m (1°F/547 ft) above 950 m (3,117 ft)

Particulate and gaseous contamination specifications

The following table defines the limitations that will help avoid any damages to the IT equipment and/or failure from particulates and gaseous contamination. If the levels of particulates or gaseous pollution exceed the specified limitations and result in equipment damage or failure, you may need to rectify the environmental conditions. Re-mediation of environmental conditions is the responsibility of the customer.

Table 17. Particulate contamination specifications

Particulate contamination	Specifications
Air Filtration	Data center air filtration as defined by ISO Class 8 per ISO 14644-1 with a 95% upper confidence limit. NOTE: This condition applies to data center environments only. Air filtration requirements do not apply to IT equipment designed to be used outside a data center, in environments such as an office or factory floor. NOTE: Air entering the data center must have MERV11 or MERV13 filtration.
Conductive dust	Air must be free of conductive dust, zinc whiskers, or other conductive particles. NOTE: This condition applies to data center and nondata center environments.
Corrosive dust	<ul style="list-style-type: none">Air must be free of corrosive dust.Residual dust present in the air must have a deliquescent point less than 60% relative humidity. NOTE: This condition applies to data center and nondata center environments.

Table 18. Gaseous contamination specifications

Gaseous contamination	Specifications
Copper Coupon Corrosion	<300 Å/month per Class G1 as defined by ANSI/ISA71.04-1985.
Silver Coupon Corrosion	<200 Å/month as defined by AHSRAE TC9.9.

NOTE: Maximum corrosive contaminant levels measured at ≤50% relative humidity.

Standard operating temperature

Table 19. Standard operating temperature specifications

Standard operating temperature	Specifications
Continuous Operation (for altitude less than 950 m or 3117 ft)	10°C to 35°C (50°F to 95°F) with no direct sunlight on the equipment.

Expanded operating temperature restrictions

Table 20. Expanded operating temperature restrictions

System	Processor configuration (in watts)	DIMM	Operating temperature
Dual processor system	120 W	RDIMM: 4 GB, 8 GB, 16 GB, and 32 GB	Up to 25°C ambient
	120 W	LRDIMM: 64 GB	Up to 20°C ambient
	105 W	RDIMM: 4 GB, 8 GB, 16 GB, and 32 GB	Up to 30°C ambient
	105 W	LRDIMM: 64 GB	Up to 25°C ambient
	90 W	RDIMM: 4 GB, 8 GB, 16 GB, and 32 GB LRDIMM: 64 GB	Up to 30°C ambient
	<=85 W	RDIMM: 4 GB, 8 GB, 16 GB, and 32 GB	Up to 35°C ambient
	<=85 W	LRDIMM: 64 GB	Up to 30°C ambient
Single processor system	140 W	RDIMM: 4 GB, 8 GB, 16 GB, and 32 GB LRDIMM: 64 GB	Up to 30°C ambient
	135 W	RDIMM: 4 GB, 8 GB, 16 GB, and 32 GB LRDIMM: 64 GB	Up to 30°C ambient
	<=120 W	RDIMM: 4 GB, 8 GB, 16 GB, and 32 GB LRDIMM: 64 GB	Up to 35°C ambient

Initial system setup and configuration

Setting up your system

Complete the following steps to set up your system:

- 1 Unpack the sled.
- 2 Remove the I/O connector cover from the sled connectors.

CAUTION: While installing the sled, ensure that it is properly aligned with the slot on the enclosure to prevent damage to the sled connectors.

- 3 Install the sled in the enclosure.
- 4 Turn on the enclosure.

NOTE: Wait for the chassis to initialize before you press the power button.

- 5 Turn on the sled by pressing the power button on the sled.

Alternatively, you can also turn on the sled by using:

- The sled iDRAC. For more information, see the Log in to iDRAC section.
- The enclosure Chassis Management Controller (CMC), after the sled iDRAC is configured on the CMC. For more information, see the *CMC User's Guide* at Dell.com/idracmanuals.

Related links

[Log in to iDRAC](#)

iDRAC configuration

The Integrated Dell Remote Access Controller (iDRAC) is designed to make system administrators more productive and improve the overall availability of Dell systems. iDRAC alerts administrators to system issues, helps them perform remote system management, and reduces the need for physical access to the system.

Options to set up iDRAC IP address

You must configure the initial network settings based on your network infrastructure to enable the communication to and from iDRAC. You can set up the IP address by using one of the following interfaces:

Interfaces	Document/Section
iDRAC Settings utility	See <i>Dell Integrated Dell Remote Access Controller User's Guide</i> at Dell.com/idracmanuals
Dell Deployment Toolkit	See <i>Dell Deployment Toolkit User's Guide</i> at Dell.com/openmanagemanuals
Dell Lifecycle Controller	See <i>Dell Lifecycle Controller User's Guide</i> at Dell.com/idracmanuals
CMC Web interface	See <i>Dell Chassis Management Controller Firmware User's Guide</i> at Dell.com/esmmanuals

You must use the default iDRAC IP address 192.168.0.120 to configure the initial network settings, including setting up DHCP or a static IP for iDRAC.

NOTE: To access iDRAC, ensure that you install the iDRAC port card or connect the network cable to the Ethernet connector 1 on the system board.

NOTE: Ensure that you change the default user name and password after setting up the iDRAC IP address.

Log in to iDRAC

You can log in to iDRAC as:

- iDRAC user
- Microsoft Active Directory user
- Lightweight Directory Access Protocol (LDAP) user

The default user name and password are `root` and `calvin`. You can also log in by using Single Sign-On or Smart Card.

NOTE: You must have iDRAC credentials to log in to iDRAC.

For more information about logging in to iDRAC and iDRAC licenses, see the *Integrated Dell Remote Access Controller User's Guide* at Dell.com/idracmanuals.

Options to install the operating system

If the system is shipped without an operating system, install the supported operating system by using one of the following resources:

Table 21. Resources to install the operating system

Resources	Location
Dell Systems Management Tools and Documentation media	Dell.com/operatingsystemmanuals
Dell Lifecycle Controller	Dell.com/idracmanuals
Dell OpenManage Deployment Toolkit	Dell.com/openmanagemanuals
Dell certified VMware ESXi	Dell.com/virtualizationsolutions
Supported operating systems on Dell PowerEdge systems	Dell.com/ossupport
Installation and How-to videos for supported operating systems on Dell PowerEdge systems	Supported Operating Systems for Dell PowerEdge Systems

Methods to download firmware and drivers

You can download the firmware and drivers by using any of the following methods:

Table 22. Firmware and drivers

Methods	Location
From the Dell Support site	Dell.com/support/home
Using Dell Remote Access Controller Lifecycle Controller (iDRAC with LC)	Dell.com/idracmanuals
Using Dell Repository Manager (DRM)	Dell.com/openmanagemanuals

Methods	Location
Using Dell OpenManage Essentials (OME)	Dell.com/openmanagemanuals
Using Dell Server Update Utility (SUU)	Dell.com/openmanagemanuals
Using Dell OpenManage Deployment Toolkit (DTK)	Dell.com/openmanagemanuals

Downloading the drivers and firmware

Dell recommends that you download and install the latest BIOS, drivers, and systems management firmware on your system.

Prerequisites

Ensure that you clear the web browser cache before downloading the drivers and firmware.

Steps

- 1 Go to **Dell.com/support/drivers**.
- 2 Under the **Drivers & Downloads** section, type the Service Tag of your system in the **Service Tag or Express Service Code** box, and then click **Submit**.
 **NOTE: If you do not have the Service Tag, select Detect My Product to allow the system to automatically detect your Service Tag, or under General support, navigate to your product.**
- 3 Click **Drivers & Downloads**.
The drivers that are applicable to your selection are displayed.
- 4 Download the drivers to a USB drive, CD, or DVD.

Pre-operating system management applications

You can manage basic settings and features of a system without booting to the operating system by using the system firmware.

Options to manage the pre-operating system applications

Your system has the following options to manage the pre-operating system applications:

- System Setup
- Boot Manager
- Dell Lifecycle Controller
- Preboot Execution Environment (PXE)

Related links

- [System Setup](#)
- [Boot Manager](#)
- [Dell Lifecycle Controller](#)
- [PXE boot](#)

System Setup

By using the **System Setup** screen, you can configure the BIOS settings, iDRAC settings, and device settings of your system.

NOTE: Help text for the selected field is displayed in the graphical browser by default. To view the help text in the text browser, press F1.

You can access system setup by using two methods:

- Standard graphical browser — The browser is enabled by default.
- Text browser — The browser is enabled by using Console Redirection.

Related links

- [System Setup details](#)
- [Viewing System Setup](#)

Viewing System Setup

To view the **System Setup** screen, perform the following steps:

- 1 Turn on, or restart your system.
- 2 Press F2 immediately after you see the following message:
F2 = System Setup

NOTE: If your operating system begins to load before you press F2, wait for the system to finish booting, and then restart your system and try again.

Related links

- [System Setup](#)
- [System Setup details](#)

System Setup details

The **System Setup Main Menu** screen details are explained as follows:

Option	Description
System BIOS	Enables you to configure BIOS settings.
iDRAC Settings	Enables you to configure iDRAC settings. The iDRAC settings utility is an interface to set up and configure the iDRAC parameters by using UEFI (Unified Extensible Firmware Interface). You can enable or disable various iDRAC parameters by using the iDRAC settings utility. For more information about this utility, see <i>Integrated Dell Remote Access Controller User's Guide</i> at Dell.com/idracmanuals .
Device Settings	Enables you to configure device settings.

Related links

- [System Setup](#)
- [Viewing System Setup](#)
- [System BIOS](#)
- [iDRAC Settings utility](#)
- [Device Settings](#)

System BIOS

You can use the **System BIOS** screen to edit specific functions such as boot order, system password, setup password, set the RAID mode, and enable or disable USB ports.

Related links

- [System BIOS Settings details](#)
- [Boot Settings](#)
- [Network Settings](#)
- [System Security](#)
- [System Information](#)
- [Memory Settings](#)
- [Processor Settings](#)
- [SATA Settings](#)
- [Integrated Devices](#)
- [Serial Communication](#)
- [System Profile Settings](#)
- [Miscellaneous Settings](#)
- [iDRAC Settings utility](#)
- [Device Settings](#)
- [Viewing System BIOS](#)

Viewing System BIOS

To view the **System BIOS** screen, perform the following steps:

- 1 Turn on, or restart your system.
- 2 Press F2 immediately after you see the following message:
F2 = System Setup

 **NOTE:** If your operating system begins to load before you press F2, wait for the system to finish booting, and then restart your system and try again.

- 3 On the **System Setup Main Menu** screen, click **System BIOS**.

Related links

[System BIOS](#)

[System BIOS Settings details](#)

System BIOS Settings details

The **System BIOS Settings** screen details are explained as follows:

Option	Description
System Information	Specifies information about the system such as the system model name, BIOS version, and Service Tag.
Memory Settings	Specifies information and options related to the installed memory.
Processor Settings	Specifies information and options related to the processor such as speed and cache size.
SATA Settings	Specifies options to enable or disable the integrated SATA controller and ports.
Boot Settings	Specifies options to specify the boot mode (BIOS or UEFI). Enables you to modify UEFI and BIOS boot settings.
Network Settings	Specifies options to change the network settings.
Integrated Devices	Specifies options to manage integrated device controllers and ports and specify related features and options.
Serial Communication	Specifies options to manage the serial ports and specify related features and options.
System Profile Settings	Specifies options to change the processor power management settings, memory frequency, and so on.
System Security	Specifies options to configure the system security settings, such as system password, setup password, Trusted Platform Module (TPM) security. It also manages the power and NMI buttons on the system.
Miscellaneous Settings	Specifies options to change the system date, time, and so on.

Related links

[System BIOS](#)

[Viewing System BIOS](#)

Boot Settings

You can use the **Boot Settings** screen to set the boot mode to either **BIOS** or **UEFI**. It also enables you to specify the boot order.

Related links

- [Boot Settings details](#)
- [System BIOS](#)
- [Viewing Boot Settings](#)
- [Choosing the system boot mode](#)
- [Changing the boot order](#)

Viewing Boot Settings

To view the **Boot Settings** screen, perform the following steps:

- 1 Turn on, or restart your system.
- 2 Press F2 immediately after you see the following message:
F2 = System Setup

 **NOTE:** If your operating system begins to load before you press F2, wait for the system to finish booting, and then restart your system and try again.



- 3 On the **System Setup Main Menu** screen, click **System BIOS**.
- 4 On the **System BIOS** screen, click **Boot Settings**.

Related links

- [Boot Settings](#)
- [Boot Settings details](#)
- [Choosing the system boot mode](#)
- [Changing the boot order](#)

Boot Settings details

The **Boot Settings** screen details are explained as follows:

Option	Description
Boot Mode	<p>Enables you to set the boot mode of the system.</p> <p> CAUTION: Switching the boot mode may prevent the system from booting if the operating system is not installed in the same boot mode.</p> <p>If the operating system supports UEFI, you can set this option to UEFI. Setting this field to BIOS allows compatibility with non-UEFI operating systems. This option is set to BIOS by default.</p> <p> NOTE: Setting this field to UEFI disables the BIOS Boot Settings menu. Setting this field to BIOS disables the UEFI Boot Settings menu.</p>
Boot Sequence Retry	<p>Enables or disables the Boot Sequence Retry feature. If this option is set to Enabled and the system fails to boot, the system reattempts the boot sequence after 30 seconds. This option is set to Enabled by default.</p>
Hard-Disk Failover	<p>Specifies the hard drive that is booted in the event of a hard drive failure. The devices are selected in the Hard-Disk Drive Sequence on the Boot Option Setting menu. When this option is set to Disabled, only the first hard drive in the list is attempted to boot. When this option is set to Enabled, all hard drives are attempted to boot in the order selected in the Hard-Disk Drive Sequence. This option is not enabled for UEFI Boot Mode.</p>
Boot Option Settings	<p>Configures the boot sequence and the boot devices.</p>
BIOS Boot Settings	<p>Enables or disables BIOS boot options.</p> <p> NOTE: This option is enabled only if the boot mode is BIOS.</p>
UEFI Boot Settings	<p>Enables or disables UEFI Boot options. The Boot options include IPv4 PXE and IPv6 PXE. This option is set to IPv4 by default.</p>

Option	Description
	 NOTE: This option is enabled only if the boot mode is UEFI.

Related links

- [Boot Settings](#)
- [Viewing Boot Settings](#)
- [Choosing the system boot mode](#)
- [Changing the boot order](#)

Choosing the system boot mode

System Setup enables you to specify one of the following boot modes for installing your operating system:

- BIOS boot mode (the default) is the standard BIOS-level boot interface.
- Unified Extensible Firmware Interface (UEFI) boot mode is an enhanced 64-bit boot interface. If you have configured your system to boot to UEFI mode, it replaces the system BIOS.

- 1 From the **System Setup Main Menu**, click **Boot Settings**, and select **Boot Mode**.
- 2 Select the boot mode you want the system to boot into.

 **CAUTION:** Switching the boot mode may prevent the system from booting if the operating system is not installed in the same boot mode.

- 3 After the system boots in the specified boot mode, proceed to install your operating system from that mode.

 **NOTE:** Operating systems must be UEFI-compatible to be installed from the UEFI boot mode. DOS and 32-bit operating systems do not support UEFI and can only be installed from the BIOS boot mode.

 **NOTE:** For the latest information about supported operating systems, go to Dell.com/ossupport.

Related links

- [Boot Settings](#)
- [Boot Settings details](#)
- [Viewing Boot Settings](#)

Changing the boot order

You may have to change the boot order if you want to boot from a USB key or an optical drive. The following instructions may vary if you have selected **BIOS** for **Boot Mode**.

- 1 On the **System Setup Main Menu** screen, click **System BIOS > Boot Settings**.
- 2 Click **Boot Option Settings > Boot Sequence**.
- 3 Use the arrow keys to select a boot device, and use the plus (+) and minus (-) sign keys to move the device down or up in the order.
- 4 Click **Exit**, and then click **Yes** to save the settings on exit.

Related links

- [Boot Settings](#)
- [Boot Settings details](#)
- [Viewing Boot Settings](#)

Network Settings

You can use the **Network Settings** screen to modify PXE device settings. The network settings option is available only in the UEFI mode.

 **NOTE:** The BIOS does not control network settings in the BIOS mode. For the BIOS boot mode, the optional Boot ROM of the network controllers handles the network settings.

Related links

- [UEFI iSCSI Settings](#)
- [Network Settings screen details](#)
- [UEFI iSCSI Settings details](#)
- [System BIOS](#)
- [Viewing Network Settings](#)
- [Viewing UEFI iSCSI Settings](#)

Viewing Network Settings

To view the **Network Settings** screen, perform the following steps:

- 1 Turn on, or restart your system.
- 2 Press F2 immediately after you see the following message:
F2 = System Setup

NOTE: If your operating system begins to load before you press F2, wait for the system to finish booting, and then restart your system and try again.

- 3 On the **System Setup Main Menu** screen, click **System BIOS**.
- 4 On the **System BIOS** screen, click **Network Settings**.

Related links

- [Network Settings](#)
- [Network Settings screen details](#)

Network Settings screen details

The **Network Settings** screen details are explained as follows:

Option	Description
PXE Device n (n = 1 to 4)	Enables or disables the device. When enabled, a UEFI boot option is created for the device.
PXE Device n Settings (n = 1 to 4)	Enables you to control the configuration of the PXE device.

Related links

- [Network Settings](#)
- [Viewing Network Settings](#)

UEFI iSCSI Settings

You can use the iSCSI Settings screen to modify iSCSI device settings. The iSCSI Settings option is available only in the UEFI boot mode. BIOS does not control network settings in the BIOS boot mode. For the BIOS boot mode, the option ROM of the network controller handles the network settings.

Related links

- [UEFI iSCSI Settings details](#)
- [Viewing UEFI iSCSI Settings](#)

Viewing UEFI iSCSI Settings

To view the **UEFI iSCSI Settings** screen, perform the following steps:

- 1 Turn on, or restart your system.
- 2 Press F2 immediately after you see the following message:
F2 = System Setup
- 3 On the **System Setup Main Menu** screen, click **System BIOS**.
- 4 On the **System BIOS** screen, click **Network Settings**.
- 5 On the **Network Settings** screen, click **UEFI iSCSI Settings**.

NOTE: If your operating system begins to load before you press F2, wait for the system to finish booting, and then restart your system and try again.

Related links

- [UEFI iSCSI Settings](#)
- [UEFI iSCSI Settings details](#)

UEFI iSCSI Settings details

The **UEFI iSCSI Settings** screen details are explained as follows:

Option	Description
iSCSI Initiator Name	Specifies the name of the iSCSI initiator (iqn format).
iSCSI Device n (n = 1 to 4)	Enables or disables the iSCSI device. When disabled, a UEFI boot option is created for the iSCSI device automatically.

Related links

- [UEFI iSCSI Settings](#)
- [Viewing UEFI iSCSI Settings](#)

System Security

You can use the **System Security** screen to perform specific functions such as setting the system password, setup password and disabling the power button.

Related links

- [System Security Settings details](#)
- [Operating with a setup password enabled](#)
- [System BIOS](#)
- [Viewing System Security](#)
- [Creating a system and setup password](#)
- [Using your system password to secure your system](#)
- [Deleting or changing system and setup password](#)

Viewing System Security

To view the **System Security** screen, perform the following steps:

- 1 Turn on, or restart your system.
- 2 Press F2 immediately after you see the following message:
F2 = System Setup

NOTE: If your operating system begins to load before you press F2, wait for the system to finish booting, and then restart your system and try again.

- 3 On the **System Setup Main Menu** screen, click **System BIOS**.
- 4 On the **System BIOS** screen, click **System Security**.

Related links

- [System Security](#)
- [System Security Settings details](#)

System Security Settings details

The **System Security Settings** screen details are explained as follows:

Option	Description
Intel AES-NI	Improves the speed of applications by performing encryption and decryption by using the Advanced Encryption Standard Instruction Set (AES-NI). This option is set to Enabled by default.
System Password	Sets the system password. This option is set to Enabled by default and is read-only if the password jumper is not installed in the system.
Setup Password	Sets the setup password. This option is read-only if the password jumper is not installed in the system.
Password Status	Locks the system password. This option is set to Unlocked by default.
TPM Security	<p>NOTE: The TPM menu is available only when the TPM module is installed.</p> <p>Enables you to control the reporting mode of the TPM. The TPM Security option is set to Off by default. You can only modify the TPM Status, TPM Activation, and Intel TXT fields if the TPM Status field is set to either On with Pre-boot Measurements or On without Pre-boot Measurements.</p>
TPM Information	Changes the operational state of the TPM. This option is set to No Change by default.
TPM Status	Specifies the TPM status.
TPM Command	<p>CAUTION: Clearing the TPM results in the loss of all keys in the TPM. The loss of TPM keys may affect booting to the operating system.</p> <p>Clears all the contents of the TPM. The TPM Clear option is set to No by default.</p>
Intel TXT	Enables or disables the Intel Trusted Execution Technology (TXT) option. To enable the Intel TXT option, virtualization technology and TPM Security must be enabled with Pre-boot measurements. This option is set to Off by default.
Power Button	Enables or disables the power button on the front of the system. This option is set to Enabled by default.
AC Power Recovery	Sets how the system behaves after AC power is restored to the system. This option is set to Last by default.
UEFI Variable Access	Provides varying degrees of securing UEFI variables. When set to Standard (the default), UEFI variables are accessible in the operating system per the UEFI specification. When set to Controlled , selected UEFI variables are protected in the environment and new UEFI boot entries are forced to be at the end of the current boot order.
Secure Boot	Enables Secure Boot, where the BIOS authenticates each pre-boot image by using the certificates in the Secure Boot Policy. Secure Boot is disabled by default.
Secure Boot Policy	When Secure Boot policy is set to Standard , the BIOS uses the system manufacturer's key and certificates to authenticate pre-boot images. When Secure Boot policy is set to Custom , the BIOS uses the user-defined key and certificates. Secure Boot policy is set to Standard by default.
Secure Boot Policy Summary	Specifies the list of certificates and hashes that secure boot uses to authenticate images.

Related links

[System Security](#)

[Viewing System Security](#)

Creating a system and setup password

Prerequisites

Ensure that the password jumper is enabled. The password jumper enables or disables the system password and setup password features. For more information, see the System board jumper settings section.

NOTE: If the password jumper setting is disabled, the existing system password and setup password are deleted and you need not provide the system password to boot the system.

Steps

- 1 To enter System Setup, press F2 immediately after turning on or rebooting your system.
- 2 On the **System Setup Main Menu** screen, click **System BIOS > System Security**.
- 3 On the **System Security** screen, verify that **Password Status** is set to **Unlocked**.
- 4 In the **System Password** field, type your system password, and press Enter or Tab.
Use the following guidelines to assign the system password:
 - A password can have up to 32 characters.
 - The password can contain the numbers 0 through 9.
 - Only the following special characters are allowed: space, ("), (+), (.), (-), (.), (/), (:), ([), (\), (]), (`).

A message prompts you to reenter the system password.

- 5 Reenter the system password, and click **OK**.
- 6 In the **Setup Password** field, type your setup password and press Enter or Tab.
A message prompts you to reenter the setup password.
- 7 Reenter the setup password, and click **OK**.
- 8 Press Esc to return to the System BIOS screen. Press Esc again.
A message prompts you to save the changes.

NOTE: Password protection does not take effect until the system reboots.

Related links

[System Security](#)

Using your system password to secure your system

If you have assigned a setup password, the system accepts your setup password as an alternate system password.

Steps

- 1 Turn on or reboot your system.
- 2 Type the system password and press Enter.

Next steps

When **Password Status** is set to **Locked**, type the system password and press Enter when prompted at reboot.

NOTE: If an incorrect system password is typed, the system displays a message and prompts you to reenter your password. You have three attempts to type the correct password. After the third unsuccessful attempt, the system displays an error message that the system has stopped functioning and must be turned off. Even after you turn off and restart the system, the error message is displayed until the correct password is entered.

Related links

[System Security](#)

Deleting or changing system and setup password

Prerequisites

NOTE: You cannot delete or change an existing system or setup password if the Password Status is set to Locked.

Steps

- 1 To enter System Setup, press F2 immediately after turning on or restarting your system.
- 2 On the **System Setup Main Menu** screen, click **System BIOS > System Security**.
- 3 On the **System Security** screen, ensure that **Password Status** is set to **Unlocked**.
- 4 In the **System Password** field, alter or delete the existing system password, and then press Enter or Tab.
- 5 In the **Setup Password** field, alter or delete the existing setup password, and then press Enter or Tab.
If you change the system and setup password, a message prompts you to reenter the new password. If you delete the system and setup password, a message prompts you to confirm the deletion.
- 6 Press Esc to return to the **System BIOS** screen. Press Esc again, and a message prompts you to save the changes.

Related links

[System Security](#)

Operating with a setup password enabled

If **Setup Password** is set to **Enabled**, type the correct setup password before modifying the system setup options.

If you do not type the correct password in three attempts, the system displays the following message:

Invalid Password! Number of unsuccessful password attempts: <x> System Halted! Must power down.

Even after you turn off and restart the system, the error message is displayed until the correct password is typed. The following options are exceptions:

- If **System Password** is not set to **Enabled** and is not locked through the **Password Status** option, you can assign a system password. For more information, see the System Security Settings screen section.
- You cannot disable or change an existing system password.

NOTE: You can use the password status option with the setup password option to protect the system password from unauthorized changes.

Related links

[System Security](#)

Secure Boot Custom Policy Settings

Secure Boot Custom Policy Settings is displayed only when **Secure Boot Policy** is set to **Custom**.

Viewing Secure Boot Custom Policy Settings

To view the **Secure Boot Custom Policy Settings** screen, perform the following steps:

- 1 Turn on, or restart your system.
- 2 Press F2 immediately after you see the following message:
F2 = System Setup

NOTE: If your operating system begins to load before you press F2, wait for the system to finish booting, and then restart your system and try again.

- 3 On the **System Setup Main Menu** screen, click **System BIOS**.

- 4 On the **System BIOS** screen, click **System Security**.
- 5 On the **System Security** screen, click **Secure Boot Custom Policy Settings**.

Secure Boot Custom Policy Settings details

The **Secure Boot Custom Policy Settings** screen details are explained as follows:

Option	Description
Platform Key	Imports, exports, deletes, or restores the platform key (PK).
Key Exchange Key Database	Enables you to import, export, delete, or restore entries in the Key Exchange Key (KEK) Database.
Authorized Signature Database	Imports, exports, deletes, or restores entries in the Authorized Signature Database (db).
Forbidden Signature Database	Imports, exports, deletes, or restores entries in the Forbidden Signature Database (dbx).

System Information

You can use the **System Information** screen to view system properties such as Service Tag, system model name, and the BIOS version.

Related links

- [System Information details](#)
- [System BIOS](#)
- [Viewing System Information](#)

Viewing System Information

To view the **System Information** screen, perform the following steps:

- 1 Turn on, or restart your system.
- 2 Press F2 immediately after you see the following message:
F2 = System Setup

NOTE: If your operating system begins to load before you press F2, wait for the system to finish booting, and then restart your system and try again.

- 3 On the **System Setup Main Menu** screen, click **System BIOS**.
- 4 On the **System BIOS** screen, click **System Information**.

Related links

- [System Information](#)

System Information details

The **System Information** screen details are explained as follows:

Option	Description
System Model Name	Specifies the system model name.
System BIOS Version	Specifies the BIOS version installed on the system.

Option	Description
System Management Engine Version	Specifies the current version of the Management Engine firmware.
System Service Tag	Specifies the system Service Tag.
System Manufacturer	Specifies the name of the system manufacturer.
System Manufacturer Contact Information	Specifies the contact information of the system manufacturer.
System CPLD Version	Specifies the current version of the system complex programmable logic device (CPLD) firmware.
UEFI Compliance Version	Specifies the UEFI compliance level of the system firmware.

Related links

- [System Information](#)
- [System Information details](#)
- [Viewing System Information](#)

Memory Settings

You can use the **Memory Settings** screen to view all the memory settings and enable or disable specific memory functions, such as system memory testing and node interleaving.

Related links

- [Memory Settings details](#)
- [System BIOS](#)
- [Viewing Memory Settings](#)

Viewing Memory Settings

To view the **Memory Settings** screen, perform the following steps:

- 1 Turn on, or restart your system.
- 2 Press F2 immediately after you see the following message:
F2 = System Setup

NOTE: If your operating system begins to load before you press F2, wait for the system to finish booting, and then restart your system and try again.

- 3 On the **System Setup Main Menu** screen, click **System BIOS**.
- 4 On the **System BIOS** screen, click **Memory Settings**.

Related links

- [Memory Settings](#)
- [Memory Settings details](#)

Memory Settings details

The **Memory Settings** screen details are explained as follows:

Option	Description
System Memory Size	Specifies the memory size in the system.
System Memory Type	Specifies the type of memory installed in the system.
System Memory Speed	Specifies the system memory speed.
System Memory Voltage	Specifies the system memory voltage.
Video Memory	Specifies the amount of video memory.
System Memory Testing	Specifies whether the system memory tests are run during system boot. Options are Enabled and Disabled . This option is set to Disabled by default.
Memory Operating Mode	Specifies the memory operating mode. The options available are Optimizer Mode , Advanced ECC Mode , Mirror Mode , Spare Mode , Spare with Advanced ECC Mode , Dell Fault Resilient Mode and Dell NUMA Fault Resilient Mode . This option is set to Optimizer Mode by default. <ul style="list-style-type: none"> i NOTE: The Memory Operating Mode option can have different default and available options based on the memory configuration of your system. i NOTE: The Dell Fault Resilient Mode option establishes an area of memory that is fault resilient. This mode can be used by an operating system that supports the feature to load critical applications or enables the operating system kernel to maximize system availability.
Node Interleaving	Specifies if Non-Uniform Memory architecture (NUMA) is supported. If this field is set to Enabled , memory interleaving is supported if a symmetric memory configuration is installed. If the field is set to Disabled , the system supports NUMA (asymmetric) memory configurations. This option is set to Disabled by default.
Snoop Mode	Specifies the Snoop Mode options. The Snoop Mode options available are Home Snoop , Early Snoop , and Cluster on Die . This option is set to Early Snoop by default. This field is available only when the Node Interleaving is set to Disabled .

Related links

- [Memory Settings](#)
- [Viewing Memory Settings](#)

Processor Settings

You can use the **Processor Settings** screen to view the processor settings, and perform specific functions such as enabling virtualization technology, hardware prefetcher, and logical processor idling.

Related links

- [Processor Settings details](#)
- [System BIOS](#)
- [Viewing Processor Settings](#)

Viewing Processor Settings

To view the **Processor Settings** screen, perform the following steps:

- 1 Turn on, or restart your system.
- 2 Press F2 immediately after you see the following message:
F2 = System Setup

i **NOTE:** If your operating system begins to load before you press F2, wait for the system to finish booting, and then restart your system and try again.

- 3 On the **System Setup Main Menu** screen, click **System BIOS**.



4 On the **System BIOS** screen, click **Processor Settings**.

Related links

- [Processor Settings](#)
- [Processor Settings details](#)

Processor Settings details

The **Processor Settings** screen details are explained as follows:

Option	Description
Logical Processor	Enables or disables the logical processors and displays the number of logical processors. If this option is set to Enabled , the BIOS displays all the logical processors. If this option is set to Disabled , the BIOS displays only one logical processor per core. This option is set to Enabled by default.
GPI Speed	Enables you to control QuickPath Interconnect data rate settings.
Alternate RTID (Requestor Transaction ID) Setting	Modifies Requestor Transaction IDs, which are QPI resources. This option is set to Disabled by default.  NOTE: Enabling this option may negatively impact the overall system performance.
Virtualization Technology	Enables or disables the additional hardware capabilities provided for virtualization. This option is set to Enabled by default.
Address Translation Service (ATS)	Defines the Address Translation Cache (ATC) for devices to cache the DMA transactions. This option provides an interface between CPU and DMA Memory Management to a chipset's Address Translation and Protection Table to translate DMA addresses to host addresses. This option is set to Enabled by default.
Adjacent Cache Line Prefetch	Optimizes the system for applications that need high utilization of sequential memory access. This option is set to Enabled by default. You can disable this option for applications that need high utilization of random memory access.
Hardware Prefetcher	Enables or disables the hardware prefetcher. This option is set to Enabled by default.
DCU Streamer Prefetcher	Enables or disables the Data Cache Unit (DCU) streamer prefetcher. This option is set to Enabled by default.
DCU IP Prefetcher	Enables or disables the Data Cache Unit (DCU) IP prefetcher. This option is set to Enabled by default.
Execute Disable	Enables you to run the disable memory protection technology. This option is set to Enabled by default.
Logical Processor Idling	Enables you to improve the energy efficiency of a system. It uses the operating system core parking algorithm and parks some of the logical processors in the system which in turn allows the corresponding processor cores to transition into a lower power idle state. This option can only be enabled if the operating system supports it. It is set to Disabled by default.
Configurable TDP	Enables you to reconfigure the processor Thermal Design Power (TDP) levels during POST based on the power and thermal delivery capabilities of the system. TDP verifies the maximum heat the cooling system is needed to dissipate. This option is set to Nominal by default.  NOTE: This option is only available on certain stock keeping units (SKUs) of the processors.
X2Apic Mode	Enables or disables the X2Apic mode.
Dell Controlled Turbo	Controls the turbo engagement. Enable this option only when System Profile is set to Performance .  NOTE: Depending on the number of installed CPUs, there may be up to four processor listings.
Number of Cores per Processor	Controls the number of enabled cores in each processor. This option is set to All by default.
Processor 64-bit Support	Specifies if the processor(s) support 64-bit extensions.

Option	Description
Processor Core Speed	Specifies the maximum core frequency of the processor.

Processor 1

 **NOTE:** Depending on the number of CPUs, there may be up to four processors listed.

The following settings are displayed for each processor installed in the system:

Option	Description
Family-Model-Stepping	Specifies the family, model, and stepping of the processor as defined by Intel.
Brand	Specifies the brand name.
Level 2 Cache	Specifies the total L2 cache.
Level 3 Cache	Specifies the total L3 cache.
Number of Cores	Specifies the number of cores per processor.

Related links

- [Processor Settings](#)
- [Viewing Processor Settings](#)

SATA Settings

You can use the **SATA Settings** screen to view the SATA settings of SATA devices and enable RAID on your system.

Related links

- [SATA Settings details](#)
- [System BIOS](#)
- [Viewing SATA Settings](#)

Viewing SATA Settings

To view the **SATA Settings** screen, perform the following steps:

- 1 Turn on, or restart your system.
- 2 Press F2 immediately after you see the following message:
F2 = System Setup

 **NOTE:** If your operating system begins to load before you press F2, wait for the system to finish booting, and then restart your system and try again.

- 3 On the **System Setup Main Menu** screen, click **System BIOS**.
- 4 On the **System BIOS** screen, click **SATA Settings**.

Related links

- [SATA Settings](#)
- [SATA Settings details](#)

SATA Settings details

The **SATA Settings** screen details are explained as follows:

Option	Description
Embedded SATA	Enables the embedded SATA option to be set to Off , ATA , AHCI , or RAID modes. This option is set to AHCI by default.
Security Freeze Lock	Sends Security Freeze Lock command to the Embedded SATA drives during POST. This option is applicable only for ATA and AHCI modes.
Write Cache	Enables or disables the command for Embedded SATA drives during POST.
Port A	Sets the drive type of the selected device. For Embedded SATA settings in ATA mode, set this field to Auto to enable BIOS support. Set it to OFF to turn off BIOS support. For AHCI or RAID mode, BIOS support is always enabled.

Option	Description
Model	Specifies the drive model of the selected device.
Drive Type	Specifies the type of drive attached to the SATA port.
Capacity	Specifies the total capacity of the hard drive. This field is undefined for removable media devices such as optical drives.

Port B	Sets the drive type of the selected device. For Embedded SATA settings in ATA mode, set this field to Auto to enable BIOS support. Set it to OFF to turn off BIOS support. For AHCI or RAID mode, BIOS support is always enabled.
---------------	--

Option	Description
Model	Specifies the drive model of the selected device.
Drive Type	Specifies the type of drive attached to the SATA port.
Capacity	Specifies the total capacity of the hard drive. This field is undefined for removable media devices such as optical drives.

Related links

- [SATA Settings](#)
- [Viewing SATA Settings](#)

Integrated Devices

You can use the **Integrated Devices** screen to view and configure the settings of all integrated devices including the video controller, integrated RAID controller, and the USB ports.

Related links

- [Integrated Devices details](#)
- [System BIOS](#)
- [Viewing Integrated Devices](#)

Viewing Integrated Devices

To view the **Integrated Devices** screen, perform the following steps:

- 1 Turn on, or restart your system.
- 2 Press F2 immediately after you see the following message:
F2 = System Setup

NOTE: If your operating system begins to load before you press F2, wait for the system to finish booting, and then restart your system and try again.

- 3 On the **System Setup Main Menu** screen, click **System BIOS**.
- 4 On the **System BIOS** screen, click **Integrated Devices**.

Related links

- [Integrated Devices](#)
- [Integrated Devices details](#)

Integrated Devices details

The **Integrated Devices** screen details are explained as follows:

Option	Description
USB 3.0 Setting	Enables or disables the USB 3.0 support. Enable this option only if your operating system supports USB 3.0. If you disable this option, devices operate at USB 2.0 speed. USB 3.0 is enabled by default.
User Accessible USB Ports	Enables or disables the USB ports. Selecting Only Back Ports On disables the front USB ports, selecting All Ports Off disables all USB ports. The USB keyboard and mouse operate during boot process in certain operating systems. After the boot process is complete, the USB keyboard and mouse do not work if the ports are disabled.  NOTE: Selecting Only Back Ports On and All Ports Off disables the USB management port and also restricts access to iDRAC features.
Internal USB Port	Enables or disables the internal USB port. This option is set to Enabled by default.
Integrated RAID Controller	Enables or disables the integrated RAID controller. This option is set to Enabled by default.
Integrated Network Card 1	Enables or disables the integrated network card.
I/OAT DMA Engine	Enables or disables the I/OAT option. Enable only if the hardware and software support the feature.
Embedded Video Controller	Enables or disables the Embedded Video Controller option. This option is set to Enabled by default.
Current State of Embedded Video Controller	Displays the current state of the embedded video controller. The Current State of Embedded Video Controller option is a read-only field. If the Embedded Video Controller is the only display capability in the system (that is, no add-in graphics card is installed), then the Embedded Video Controller is automatically used as the primary display even if the Embedded Video Controller setting is set to Disabled .
SR-IOV Global Enable	Enables or disables the BIOS configuration of Single Root I/O Virtualization (SR-IOV) devices. This option is set to Disabled by default.
OS Watchdog Timer	If your system stops responding, this watchdog timer aids in the recovery of your operating system. When this option is set to Enabled , the operating system initializes the timer. When this option is set to Disabled (the default), the timer does not have any effect on the system.
Memory Mapped I/O above 4 GB	Enables or disables the support for PCIe devices that need large amounts of memory. This option is set to Enabled by default.
Mezzanine Slot Disablement	The Slot Disablement feature controls the configuration of mezzanine cards installed in the specified slots. Only mezzanine card slots that are present on your system are available for control.

Related links

- [Integrated Devices](#)
- [Viewing Integrated Devices](#)

Serial Communication

You can use the **Serial Communication** screen to view the properties of the serial communication port.

Related links

- [Serial Communication details](#)
- [System BIOS](#)
- [Viewing Serial Communication](#)

Viewing Serial Communication

To view the **Serial Communication** screen, perform the following steps:

- 1 Turn on, or restart your system.
- 2 Press F2 immediately after you see the following message:
F2 = System Setup

NOTE: If your operating system begins to load before you press F2, wait for the system to finish booting, and then restart your system and try again.

- 3 On the **System Setup Main Menu** screen, click **System BIOS**.
- 4 On the **System BIOS** screen, click **Serial Communication**.

Related links

- [Serial Communication](#)
- [Serial Communication details](#)

Serial Communication details

The **Serial Communication** screen details are explained as follows:

Option	Description
Serial Communication	Enables the COM port or Console Redirection options. This option is set to Off by default.
Serial Port Address	Enables you to set the port address for serial devices. This option is set to Serial Device 1=COM2, Serial Device 2=COM1 by default. NOTE: You can use only Serial Device 2 for the Serial Over LAN (SOL) feature. To use console redirection by SOL, configure the same port address for console redirection and the serial device.
External Serial Connector	Enables you to associate the External Serial Connector to Serial Device 1.
Failsafe Baud Rate	Specifies the failsafe baud rate for console redirection. The BIOS attempts to determine the baud rate automatically. This failsafe baud rate is used only if the attempt fails, and the value must not be changed. This option is set to 115200 by default.
Remote Terminal Type	Sets the remote console terminal type. This option is set to VT 100/VT 220 by default.
Redirection After Boot	Enables or disables the BIOS console redirection when the operating system is loaded. This option is set to Enabled by default.

Related links

- [Serial Communication](#)
- [Viewing Serial Communication](#)

System Profile Settings

You can use the **System Profile Settings** screen to enable specific system performance settings such as power management.

Related links

- [System Profile Settings details](#)
- [System BIOS](#)
- [Viewing System Profile Settings](#)

Viewing System Profile Settings

To view the **System Profile Settings** screen, perform the following steps:

- 1 Turn on, or restart your system.
- 2 Press F2 immediately after you see the following message:
F2 = System Setup

NOTE: If your operating system begins to load before you press F2, wait for the system to finish booting, and then restart your system and try again.

- 3 On the **System Setup Main Menu** screen, click **System BIOS**.
- 4 On the **System BIOS** screen, click **System Profile Settings**.



Related links

- [System Profile Settings](#)
- [System Profile Settings details](#)

System Profile Settings details

The **System Profile Settings** screen details are explained as follows:

Option	Description
System Profile	Sets the system profile. If you set the System Profile option to a mode other than Custom , the BIOS automatically sets the rest of the options. You can only change the rest of the options if the mode is set to Custom . This option is set to Performance Per Watt Optimized (DAPC) by default. DAPC is Dell Active Power Controller. NOTE: All the parameters on the system profile setting screen are available only when the System Profile option is set to Custom .
CPU Power Management	Sets the CPU power management. This option is set to System DBPM (DAPC) by default. DBPM is Demand-Based Power Management.
Memory Frequency	Sets the speed of the system memory. You can select Maximum Performance , Maximum Reliability , or a specific speed.
Turbo Boost	Enables or disables the processor to operate in the turbo boost mode. This option is set to Enabled by default.
Energy Efficient Turbo	Enables or disables the Energy Efficient Turbo option. Energy Efficient Turbo (EET) is a mode of operation where a processor's core frequency is adjusted to be within the turbo range based on workload.
C1E	Enables or disables the processor to switch to a minimum performance state when it is idle. This option is set to Enabled by default.
C States	Enables or disables the processor to operate in all available power states. This option is set to Enabled by default.

Option	Description
Collaborative CPU Performance Control	Enables or disables the CPU power management option. When set to Enabled , the CPU power management is controlled by the OS DBPM and the System DBPM (DAPC). This option is set to Disabled by default.
Memory Patrol Scrub	Sets the memory patrol scrub frequency. This option is set to Standard by default.
Memory Refresh Rate	Sets the memory refresh rate to either 1x or 2x. This option is set to 1x by default.
Uncore Frequency	Enables you to select the Processor Uncore Frequency option. Dynamic mode enables the processor to optimize power resources across the cores and uncore during runtime. The optimization of the uncore frequency to either save power or optimize performance is influenced by the setting of the Energy Efficiency Policy option.
Energy Efficient Policy	Enables you to select the Energy Efficient Policy option. The CPU uses the setting to manipulate the internal behavior of the processor and determines whether to target higher performance or better power savings.
Number of Turbo Boot Enabled Cores for Processor 1	<p> NOTE: If there are two processors installed in the system, you see an entry for Number of Turbo Boost Enabled Cores for Processor 2.</p> <p>Controls the number of turbo boost enabled cores for processor 1. The maximum number of cores is enabled by default.</p>
Monitor/Mwait	<p>Enables the Monitor/Mwait instructions in the processor. This option is set to Enabled for all system profiles, except Custom by default.</p> <p> NOTE: This option can be disabled only if the C States option in the Custom mode is set to disabled.</p> <p> NOTE: When C States is set to Enabled in the Custom mode, changing the Monitor/Mwait setting does not impact the system power or performance.</p>

Related links

- [System Profile Settings](#)
- [Viewing System Profile Settings](#)

Miscellaneous Settings

You can use the **Miscellaneous Settings** screen to perform specific functions such as updating the asset tag and changing the system date and time.

Related links

- [Miscellaneous Settings details](#)
- [System BIOS](#)
- [Viewing Miscellaneous Settings](#)

Viewing Miscellaneous Settings

To view the **Miscellaneous Settings** screen, perform the following steps:

- 1 Turn on, or restart your system.
- 2 Press F2 immediately after you see the following message:
F2 = System Setup

 **NOTE: If your operating system begins to load before you press F2, wait for the system to finish booting, and then restart your system and try again.**



- 3 On the **System Setup Main Menu** screen, click **System BIOS**.
- 4 On the **System BIOS** screen, click **Miscellaneous Settings**.

Related links

- [Miscellaneous Settings](#)
- [Miscellaneous Settings details](#)

Miscellaneous Settings details

The **Miscellaneous Settings** screen details are explained as follows:

Option	Description
System Time	Enables you to set the time on the system.
System Date	Enables you to set the date on the system.
Asset Tag	Specifies the asset tag and enables you to modify it for security and tracking purposes.
Keyboard NumLock	Enables you to set whether the system boots with the NumLock enabled or disabled. This option is set to On by default.  NOTE: This option does not apply to 84-key keyboards.
F1/F2 Prompt on Error	Enables or disables the F1/F2 prompt on error. This option is set to Enabled by default. The F1/F2 prompt also includes keyboard errors.
Load Legacy Video Option ROM	Enables you to determine whether the system BIOS loads the legacy video (INT 10H) option ROM from the video controller. Selecting Enabled in the operating system does not support UEFI video output standards. This field is available only for UEFI boot mode. You cannot set the option to Enabled if UEFI Secure Boot mode is enabled.
In-System Characterization	Enables or disables In-System Characterization . This option is set to Disabled by default. The two other options are Enabled and Enabled - No Reboot .  NOTE: The default setting for In-System Characterization is subject to change in future BIOS releases. When enabled, In-System Characterization (ISC) executes during POST upon detecting relevant change(s) in system configuration to optimize system power and performance. ISC takes about 20 seconds to execute, and system reset is needed for ISC results to be applied. The Enabled - No Reboot option executes ISC and continues without applying ISC results until the next time system reset occurs. The Enabled option executes ISC and forces an immediate system reset so that ISC results can be applied. It takes the system longer to be ready due to the forced system reset. When disabled, ISC does not execute.

Related links

- [Miscellaneous Settings](#)
- [Viewing Miscellaneous Settings](#)

iDRAC Settings utility

The iDRAC settings utility is an interface to set up and configure the iDRAC parameters by using UEFI. You can enable or disable various iDRAC parameters by using the iDRAC settings utility.

 **NOTE: Accessing some of the features on the iDRAC settings utility needs the iDRAC Enterprise License upgrade.**

For more information about using iDRAC, see *Dell Integrated Dell Remote Access Controller User's Guide* at Dell.com/idracmanuals.

Related links

- [Device Settings](#)
- [System BIOS](#)
- [Entering the iDRAC Settings utility](#)
- [Changing the thermal settings](#)

Entering the iDRAC Settings utility

- 1 Turn on or restart the managed system.
- 2 Press F2 during Power-on Self-test (POST).
- 3 On the **System Setup Main Menu** page, click **iDRAC Settings**.
The **iDRAC Settings** screen is displayed.

Related links

[iDRAC Settings utility](#)

Changing the thermal settings

The iDRAC settings utility enables you to select and customize the thermal control settings for your system.

- 1 Click **iDRAC Settings > Thermal**.
- 2 Under **SYSTEM THERMAL PROFILE > Thermal Profile**, select one of the following options:
 - Default Thermal Profile Settings
 - Maximum Performance (Performance Optimized)
 - Minimum Power (Performance per Watt Optimized)
- 3 Under **USER COOLING OPTIONS**, set the **Fan Speed Offset**, **Minimum Fan Speed**, and **Custom Minimum Fan Speed**.
- 4 Click **Back > Finish > Yes**.

Related links

[iDRAC Settings utility](#)

Device Settings

Device Settings enables you to configure device parameters.

Related links

[System BIOS](#)

Dell Lifecycle Controller

Dell Lifecycle Controller (LC) provides advanced embedded systems management capabilities including system deployment, configuration, update, maintenance, and diagnosis. LC is delivered as part of the iDRAC out-of-band solution and Dell system embedded Unified Extensible Firmware Interface (UEFI) applications.

Related links

[Embedded systems management](#)

Embedded systems management

The Dell Lifecycle Controller provides advanced embedded systems management throughout the system's lifecycle. The Dell Lifecycle Controller can be started during the boot sequence and can function independently of the operating system.

NOTE: Certain platform configurations may not support the full set of features provided by the Dell Lifecycle Controller.

For more information about setting up the Dell Lifecycle Controller, configuring hardware and firmware, and deploying the operating system, see the Dell Lifecycle Controller documentation at [Dell.com/idracmanuals](https://www.dell.com/support/manuals).

Related links

[Dell Lifecycle Controller](#)

Boot Manager

The **Boot Manager** screen enables you to select boot options and diagnostic utilities.

Related links

[Boot Manager main menu](#)

[System BIOS](#)

[Viewing Boot Manager](#)

Viewing Boot Manager

To enter **Boot Manager**:

- 1 Turn on, or restart your system.
- 2 Press F11 when you see the following message:
F11 = Boot Manager

If your operating system begins to load before you press F11, allow the system to complete the booting, and then restart your system and try again.

Related links

[Boot Manager](#)

[Boot Manager main menu](#)

Boot Manager main menu

Menu item	Description
Continue Normal Boot	The system attempts to boot to devices starting with the first item in the boot order. If the boot attempt fails, the system continues with the next item in the boot order until the boot is successful or no more boot options are found.
One-shot Boot Menu	Enables you to access boot menu, where you can select a one-time boot device to boot from.
Launch System Setup	Enables you to access System Setup.
Launch Lifecycle Controller	Exits the Boot Manager and invokes the Dell Lifecycle Controller program.
System Utilities	Enables you to launch System Utilities menu such as System Diagnostics and UEFI shell.

Related links

[Boot Manager](#)

[Viewing Boot Manager](#)

One-shot BIOS boot menu

One-shot BIOS boot menu enables you to select a boot device to boot from.

Related links

[Boot Manager](#)

System Utilities

System Utilities contains the following utilities that can be launched:

- Launch Diagnostics
- BIOS Update File Explorer
- Reboot System

Related links

[Boot Manager](#)

PXE boot

You can use the Preboot Execution Environment (PXE) option to boot and configure the networked systems, remotely.

NOTE: To access the PXE boot option, boot the system and then press F12. The system scans and displays the active networked systems.

Installing and removing sled components

This section provides information about installing and removing the sled components. For information about installing and removing the enclosure components, see the enclosure Owner's Manual at [Dell.com/poweredgemanuals](https://Dell.com/poweredge/manuals).

Topics:

- Safety instructions
- Recommended tools
- Sled
- Inside the sled
- Cooling shroud
- System memory
- PCIe mezzanine card
- Internal Dual SD Module (IDSDM) card
- SD vFlash card
- LAN on Motherboard (LOM) riser card
- Processors
- Processor blank and DIMM blank
- Solid State Drives (SSD)
- Solid State Drive (SSD) backplane
- System battery
- System board
- Trusted Platform Module

Safety instructions

CAUTION: Many repairs may only be done by a certified service technician. You should only perform troubleshooting and simple repairs as authorized in your product documentation, or as directed by the online or telephone service and support team. Damage due to servicing that is not authorized by Dell is not covered by your warranty. Read and follow the safety instructions that are shipped with your product.

NOTE: Dell recommends that you always use an antistatic mat and antistatic wrist strap while working on components inside the system.

CAUTION: Operating the system without the system cover can result in component damage

NOTE: To ensure proper operation and cooling, all bays in the system must be populated always with either a system component or with a blank.

Before working inside your system

Prerequisites

Follow the safety guidelines listed in safety instructions section.

Steps

- 1 Turn off the sled by using the Chassis Management Controller (CMC).
- 2 Remove the sled from the enclosure.
- 3 Install the I/O connector cover.

After working inside your system

Prerequisites

Follow the safety guidelines listed in safety instructions section.

Steps

- 1 Install the sled in the enclosure.
- 2 Turn on the sled.

Recommended tools

You need the following tools to perform the removal and installation procedures:

- Phillips #1 screwdriver
- Phillips #2 screwdriver
- 4 mm and 5 mm Hex nut driver
- Wrist grounding strap

Sled

Removing a sled

Prerequisites

- 1 Follow the safety guidelines listed in the Safety instructions section.
- 2 Follow the procedure listed in the Before working inside your system section.

Steps

- 1 Turn off the sled.

NOTE: When a sled is turned off, the front-panel power indicator is OFF.

- 2 Press the release button on the sled handle and rotate the sled handle away from the sled to disengage the sled from the interposer connectors.
- 3 Slide the sled out of the enclosure.

CAUTION: If you are permanently removing the sled, install a sled blank. Operating the system for extended periods of time without a sled blank installed can cause the enclosure to overheat.

NOTE: For more information about the interposer connections, see *Dell PowerEdge FX2 and FX2s Enclosure Owner's Manual* at Dell.com/poweredgemanuals.

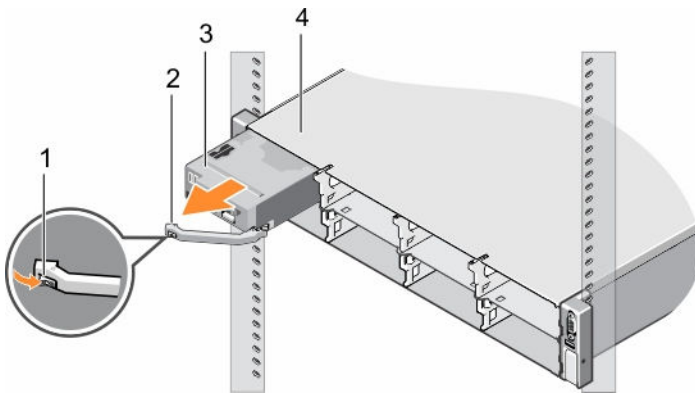

Figure 7. Removing a sled

- | | | | |
|---|----------------|---|-----------------------|
| 1 | release button | 2 | sled handle |
| 3 | sled | 4 | FX2 or FX2s enclosure |

Next steps

- 1 Follow the procedure listed in the After working inside your system section.

Related links

- [Safety instructions](#)
- [Before working inside your system](#)
- [After working inside your system](#)

Installing a sled

Prerequisites

Follow the safety guidelines listed in the Safety instructions section.

Steps

- 1 Press the release button on the sled handle to the open position.
- 2 Align the sled with the bay on the enclosure.
- 3 Slide the sled into the enclosure until the sled connectors are firmly engaged with the interposer connectors.
The sled handle rotates toward the enclosure as the sled slides into the enclosure.
- 4 Press the sled handle to closed position until the release button clicks into place.
- 5 Turn on the sled.

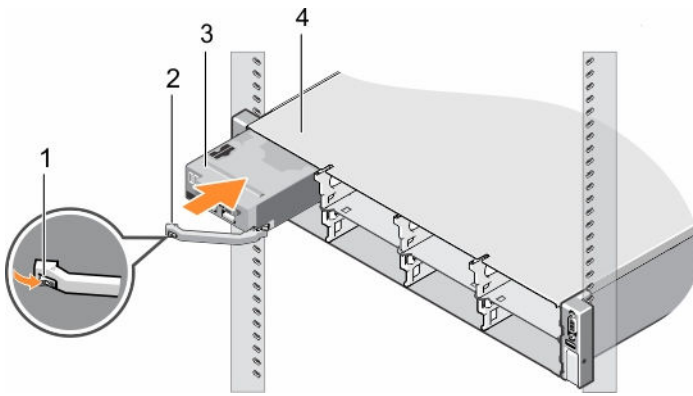

Figure 8. Installing a sled

- | | | | |
|---|----------------|---|-----------------------|
| 1 | release button | 2 | sled handle |
| 3 | sled | 4 | FX2 or FX2s enclosure |

Related links

[Safety instructions](#)

Inside the sled

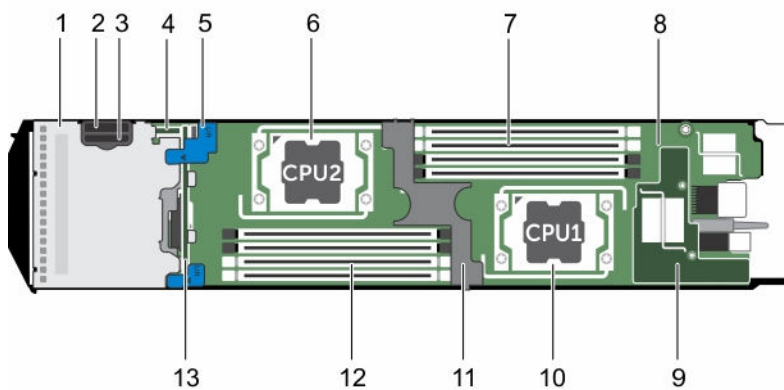

Figure 9. Inside the sled

- | | | | |
|----|------------------------------|----|-----------------------------------|
| 1 | SSD cage | 2 | vFlash/SD card multifunction slot |
| 3 | SD card slot | 4 | IDSDM card |
| 5 | SSD backplane touch points | 6 | processor 2 |
| 7 | memory modules (processor 1) | 8 | system board |
| 9 | LAN on Motherboard riser | 10 | processor 1 |
| 11 | cooling shroud | 12 | memory modules (processor 2) |
| 13 | SSD backplane | | |

Cooling shroud

The cooling shroud has aerodynamically placed openings that directs the airflow across the entire system. The airflow passes through all the critical parts of the system, where the vacuum that pulls air across the entire surface area of the processor and heat sink allowing increased cooling.

Removing the cooling shroud

Prerequisites

⚠ CAUTION: Many repairs may only be done by a certified service technician. You should only perform troubleshooting and simple repairs as authorized in your product documentation, or as directed by the online or telephone service and support team. Damage due to servicing that is not authorized by Dell is not covered by your warranty. Read and follow the safety instructions that are shipped with your product.

⚠ CAUTION: Never operate your system with the cooling shroud removed. The system may get overheated quickly, resulting in shutdown of the system and loss of data.

- 1 Follow the safety guidelines listed in the Safety instructions section.
- 2 Follow the procedure listed in the Before working inside your system section.

Steps

Holding the touch points, lift the cooling shroud away from the system.

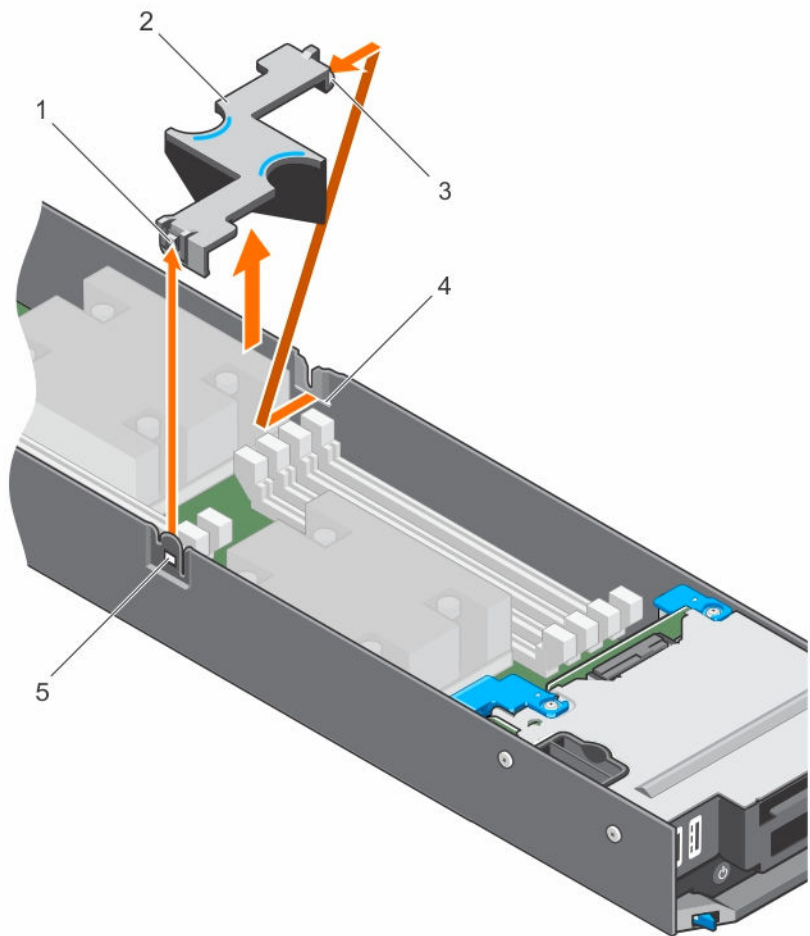

Figure 10. Removing the cooling shroud

- | | | | |
|---|--------------------------------------|---|----------------------|
| 1 | cooling shroud latch | 2 | touch points |
| 3 | cooling shroud | 4 | cooling shroud guide |
| 5 | cooling shroud guide slot on chassis | | |

Next steps

- 1 Install the cooling shroud.
- 2 Follow the procedure listed in the After working inside your system section.

Related links

- [Safety instructions](#)
- [Before working inside your system](#)
- [Installing the cooling shroud](#)
- [After working inside your system](#)

Installing the cooling shroud

Prerequisites

CAUTION: Many repairs may only be done by a certified service technician. You should only perform troubleshooting and simple repairs as authorized in your product documentation, or as directed by the online or telephone service and support team. Damage due to servicing that is not authorized by Dell is not covered by your warranty. Read and follow the safety instructions that came with the product.

NOTE: You must remove the cooling shroud to service other components inside the system.

- 1 Follow the safety guidelines listed in the Safety instructions section.
- 2 Follow the procedure listed in the Before working inside your system section.

Steps

- 1 Align the cooling shroud guide with the guide slot on the chassis.
- 2 Press the cooling shroud into the system until the release latch engages with the slot on the chassis and clicks into place.

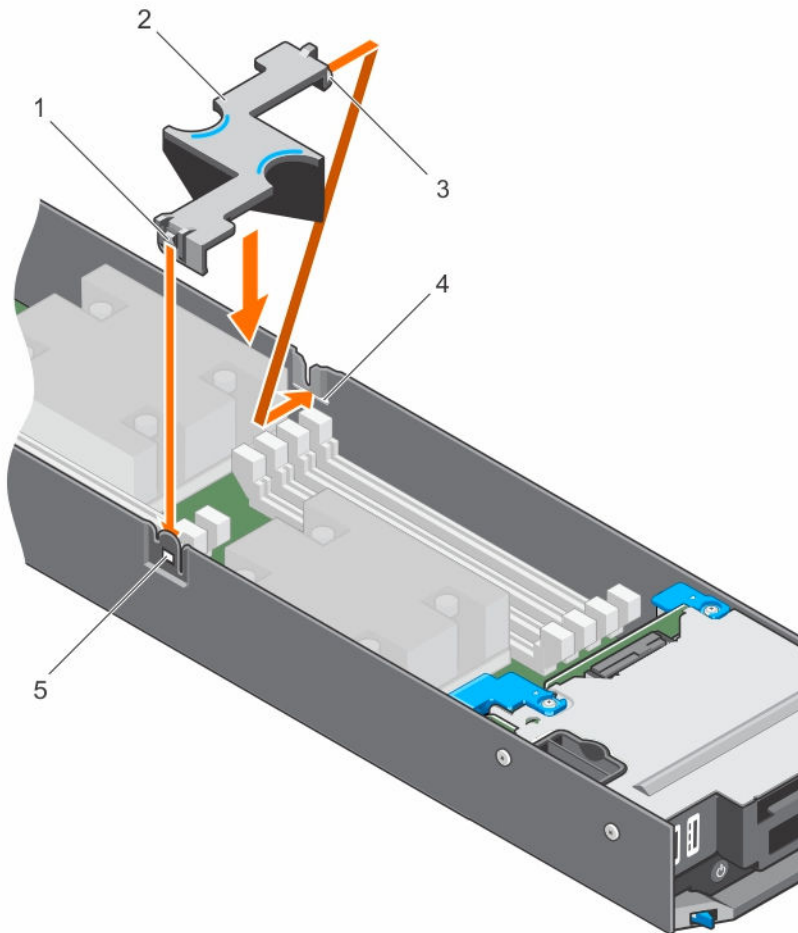

Figure 11. Installing the cooling shroud

- | | | | |
|---|----------------------|---|----------------------|
| 1 | cooling shroud latch | 2 | finger hold points |
| 3 | cooling shroud | 4 | cooling shroud guide |

Next steps

Follow the procedure listed in the After working inside your system section.

Related links

- [Safety instructions](#)
- [Before working inside your system](#)
- [After working inside your system](#)
- [Removing the cooling shroud](#)

System memory

Your system supports DDR4 registered DIMMs (RDIMMs and LRDIMMs), and DDR4 voltage specifications.

NOTE: MT/s indicates DIMM speed in MegaTransfers per second.

Memory bus operating frequency can be 2400 MT/s, 2133 MT/s, or 1866 MT/s depending on:

- System profile selected (for example, Performance Optimized, Custom, or Dense Configuration Optimized)
- Maximum supported DIMM frequency of the processors

The system contains eight memory sockets split into two sets of four sockets, one set per processor. DIMMs in sockets A1 to A4 are assigned to processor 1 and DIMMs in sockets B1 to B4 are assigned to processor 2. The system supports one DIMM per channel. In each four socket set, the release levers of the first-to-populate socket are marked white and those of the second socket are marked black. The DIMM sockets A3, A4, B3, and B4 need to have the memory module inserted 180° reverse with regard to the DIMMS in the A1, A2, and B1, B2 sockets.

The following table shows the memory populations and operating frequencies for the supported configurations.

Table 23. Memory population—operating frequency for supported configuration

DIMM Type	DIMMs populated per channel	Voltage	Operating Frequency (in MT/s)	Maximum DIMM Rank Per Channel
RDIMM	1	1.2 v	2400, 2133, 1866	Single rank
			2400, 2133, 1866	Dual rank
LRDIMM	1	1.2v	2400, 2133, 1866	Quad rank

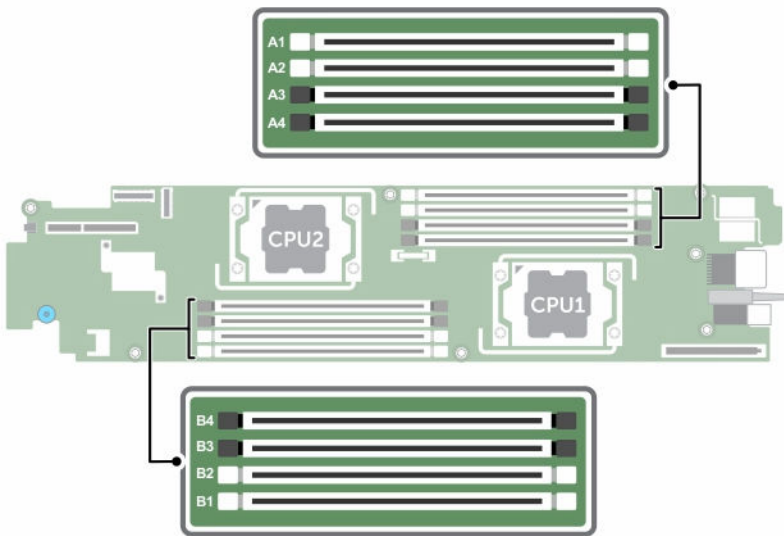

Figure 12. Memory socket locations

Memory channels are organized as follows:

- Processor 1
 - channel 0: slot A2
 - channel 1: slot A1
 - channel 2: slot A3
 - channel 3: slot A4
- Processor 2
 - channel 0: slot B2
 - channel 1: slot B1
 - channel 2: slot B3
 - channel 3: slot B4

General memory module installation guidelines

NOTE: Memory configurations that fail to observe these guidelines can prevent your system from booting, stop responding during memory configuration, or operating with reduced memory.

The system supports Flexible Memory Configuration, enabling the system to be configured and run in any valid chipset architectural configuration. The following are the recommended guidelines for installing memory modules:

- x4 and x8 DRAM based memory modules can be mixed. For more information, see the Mode-specific guidelines section.
- Up to three dual- or single-rank RDIMMs can be populated per channel.
- If memory modules with different speeds are installed, they will operate at the speed of the slowest installed memory module(s) or slower depending on system DIMM configuration.
- Populate memory module sockets only if a processor is installed. For single-processor systems, sockets A1 to A4 are available. For dual-processor systems, sockets A1 to A4 and sockets B1 to B4 are available.
- Populate all the sockets with white release tabs first, followed by the black release tabs, and then the green release tabs.
- When mixing memory modules with different capacities, populate the sockets with memory modules with highest capacity first. For example, if you want to mix 4 GB and 8 GB memory modules, populate 8 GB memory modules in the sockets with white release tabs and 4 GB memory modules in the sockets with black release tabs.
- In a dual-processor configuration, the memory configuration for each processor should be identical. For example, if you populate socket A1 for processor 1, then populate socket B1 for processor 2, and so on.
- Memory modules of different capacities can be mixed provided other memory population rules are followed (for example, 4 GB and 8 GB memory modules can be mixed).
- The memory module for DIMM sockets A3, A4, B3, and B4 need to be inserted 180° reverse with regard to the DIMMs in the sockets A1, A2, B1, and B2.
- Mixing of more than two memory module capacities in a system is not supported.
- Populate four memory modules per processor (one DIMM per channel) at a time to maximize performance.

Table 24. Heat sink—processor configurations

Processor configuration	Processor type (in Watts)	Heat sink width	Number of DIMMs	
			Maximum system capacity	Reliability, Availability, and Serviceability (RAS) features
Dual processor	Up to 120 W	61 mm	8	8
	140 W	96 mm	4	4
Single processor	120 W	61 mm	4	4

Related links

[Mode-specific guidelines](#)

Mode-specific guidelines

Four memory channels are allocated to each processor. The allowable configurations depend on the memory mode selected.

Advanced Error Correction Code (lockstep)

Advanced Error Correction Code (ECC) mode extends SDDC from x4 DRAM based DIMMs to both x4 and x8 DRAMs. This protects against single DRAM chip failures during normal operation.

The installation guidelines for memory modules are as follows:

- Memory modules must be identical in size, speed, and technology.
- DIMMs installed in memory sockets with white release levers must be identical and the same rule applies for sockets with black release levers. This ensures that identical DIMMs are installed in matched pair —for example, A1 with A2, A3 with A4, A5 with A6, and so on.
- DIMMs installed in memory sockets with white release tabs must be identical and similar rule applies for sockets with black release tabs. This ensures that identical DIMMs are installed in matched pairs- for example, A1 with A2, A3 with A4 and so on.

Table 25. Advanced ECC (Lockstep)

Processor	Configuration	Memory population rules	Memory population information
Single CPU	Advanced ECC (Lockstep)	{1,2}, {3,4}	Numbers inside the brackets indicate the slots that must be populated in pairs, odd amount of pairs allowed.
Dual CPU	Advanced ECC (Lockstep)	C1{1,2},C2{1,2},C1{3,4},C2{3,4}...	Numbers inside the brackets indicate the slots that must be populated in pairs, odd amount of pairs allowed.

NOTE: Populate round robin starting with CPU1

NOTE: Advanced ECC with mirroring is not supported.

Memory optimized (independent channel) mode

This mode supports Single Device Data Correction (SDDC) only for memory modules that use x4 device width. It does not impose any specific slot population requirements.

Table 26. Memory optimized (independent channel) mode

Processor	Configuration	Memory population rules	Memory population information
Single CPU	Optimized (independent channel)	1, 2, 3, 4	Populate in this order, odd amount of DIMMs per CPU allowed.
Dual CPU	Optimized (independent channel)	C1{1}, C2{1}, C1{2}, C2{2}, C1{3}, C2{3}...	Populate in this order, odd amount of DIMMs per CPU allowed.

NOTE: Optimized mode permits unbalanced configurations, eg, 1:1:1:0 DIMM per channel (DPC) combinations.

NOTE: Populate round robin starting with CPU1:

NOTE: Optimized mode permits unbalanced configurations, eg, 2:1:1:1 DPC combinations.

Memory mirroring

Memory mirroring offers the strongest memory module reliability mode compared to all other modes, providing improved uncorrectable multi-bit failure protection. In a mirrored configuration, the total available system memory is one half of the total installed physical memory. Half of the installed memory is used to mirror the active memory modules. In the event of an uncorrectable error, the system switches over to the mirrored copy. This ensures SDDC and multi-bit protection.

The installation guidelines for memory modules are as follows:

- Memory modules must be identical in size, speed, and technology.
- DIMMs installed in memory sockets with white release tabs must be identical and similar rule applies for sockets with black release tabs. This ensures that identical DIMMs are installed in matched pairs—for example, A1 with A2, A3 with A4.

NOTE: Mirroring and Advanced ECC modes require minimum of two DIMMs per CPU and must be populated in pairs of either two or four DIMMs per CPU.

Table 27. Processor configuration

Processor	Configuration	Memory population rules	Memory population information
Single CPU	Memory population order	{1,2}, {3,4}	See Memory mirroring note

Sample memory configurations

The following tables show sample memory configurations that follow the appropriate memory guidelines stated in this section.

NOTE: 1R, 2R, and 4R in the following tables indicate single rank, dual rank, and quad rank DIMMs respectively.

Table 28. Memory configurations—single processor

System Capacity (in GB)	DIMM Size (in GB)	Number of DIMMs	Organization and Speed	DIMM Slot Population
4	4	1	1R x8, 2400 MT/s	A1
8	4	2	1R x8, 2400 MT/s	A1, A2
8	8	1	1R x8, 2400 MT/s	A1
16	4	4	1R x8, 2400 MT/s	A1, A2, A3, A4
16	8	1	1R x8 2400 MT/s	A1, A2
16	16	1	2R x8, 2400 MT/s	A1
32	8	4	1R x8 2400 MT/s	A1, A2, A3, A4
32	16	2	2R x8, 2400 MT/s	A1, A2
32	32	1	2R x4, 2400 MT/s	A1
64	16	4	2R x8, 2400 MT/s	A1, A2, A3, A4
64	32	2	2R x4, 2400 MT/s	A1, A2
64	64	1	4R x4, 2400 MT/s	A1
128	32	4	2R x4, 2400 MT/s	A1, A2, A3, A4
128	64	2	4R x4, 2400 MT/s	A1, A2
256	64	4	4R x4, 2400 MT/s	A1, A2, A3, A4

Table 29. Memory configurations—dual processor

System Capacity (in GB)	DIMM Size (in GB)	Number of DIMMs	Organization and Speed	DIMM Slot Population
8	4	2	1R x8, 2400 MT/s	A1, B1
16	4	4	1R x8, 2400 MT/s	A1, A2, B1, B2
16	8	2	1R x8, 2400 MT/s	A1, B1
32	4	8	1R x8, 2400 MT/s	A1, A2, A3, A4, B1, B2, B3, B4
32	8	4	1R x8, 2400 MT/s	A1, A2, B1, B2
32	16	2	2R x8 2400 MT/s	A1, B1
64	8	8	1R x8, 2400 MT/s	A1, A2, A3, A4, B1, B2, B3, B4
64	16	4	2R x8 2400 MT/s	A1, A2, B1, B2
64	32	2	2R x4, 2400 MT/s	A1, B1
128	16	8	2R x8 2400 MT/s	A1, A2, A3, A4, B1, B2, B3, B4
128	32	4	2R x4, 2400 MT/s	A1, A2, B1 B2
128	64	2	4R x4, 2400 MT/s	A1, B1
256	32	8	2R x4, 2400 MT/s	A1, A2, A3, A4, B1, B2, B3, B4
256	64	4	4R x4, 2400 MT/s	A1, A2, B1 B2
512	64	8	4R x4, 2400 MT/s	A1, A2, A3, A4, B1, B2, B3, B4

Removing memory modules

Prerequisites

⚠ CAUTION: Many repairs may only be done by a certified service technician. You should only perform troubleshooting and simple repairs as authorized in your product documentation, or as directed by the online or telephone service and support team. Damage due to servicing that is not authorized by Dell is not covered by your warranty. Read and follow the safety instructions that are shipped with your product.

- 1 Follow the safety guidelines listed in the Safety instructions section.
- 2 Follow the procedure listed in the Before working inside your system section.
- 3 Remove the cooling shroud.

⚠ WARNING: The memory modules are hot to touch for some time after the system has been powered down. Allow the memory modules to cool before handling them. Handle the memory modules by the card edges and avoid touching the components or metallic contacts on the memory module.

⚠ CAUTION: To ensure proper system cooling, memory module blanks must be installed in any memory socket that is not occupied. Remove memory module blanks only if you intend to install memory modules in those sockets.

Steps

1 Locate the appropriate memory module socket.

CAUTION: Handle each memory module only by the card edges, ensuring not to touch the middle of the memory module or metallic contacts.

2 To release the memory module from the socket, simultaneously press the ejectors on both ends of the memory module socket.

3 Lift and remove the memory module from the system.

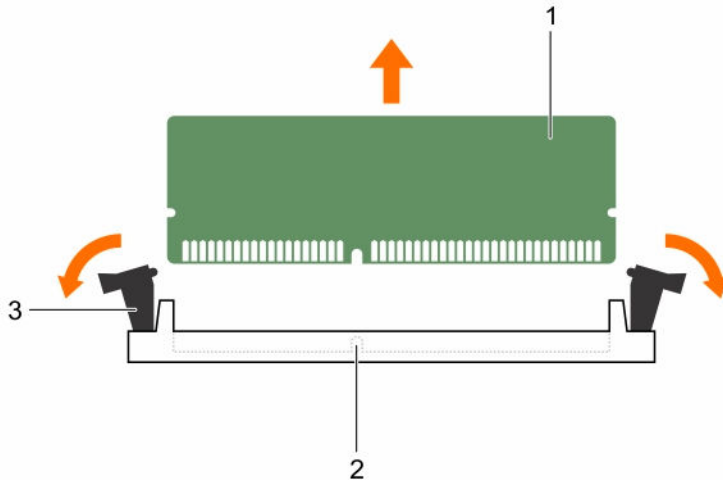

Figure 13. Removing the memory module

1 memory module

2 memory module socket

3 memory module socket ejector (2)

Next steps

1 Install the memory module.

NOTE: If you are removing the memory module permanently, install a memory module blank.

2 Install the cooling shroud.

3 Follow the procedure listed in the After working inside your system section.

Related links

[Safety instructions](#)

[Before working inside your system](#)

[Removing the cooling shroud](#)

[Installing memory modules](#)

[Installing the cooling shroud](#)

[After working inside your system](#)

Installing memory modules

Prerequisites

- ⚠ WARNING:** The memory modules are hot to touch for some time after the system has been powered down. Allow the memory modules to cool before handling them. Handle the memory modules by the card edges and avoid touching the components or metallic contacts on the memory module.
 - ⚠ CAUTION:** Many repairs may only be done by a certified service technician. You should only perform troubleshooting and simple repairs as authorized in your product documentation, or as directed by the online or telephone service and support team. Damage due to servicing that is not authorized by Dell is not covered by your warranty. Read and follow the safety instructions that are shipped with your product.
 - ⚠ CAUTION:** To ensure proper system cooling, memory module blanks must be installed in any memory socket that is not occupied. Remove memory module blanks only if you intend to install memory modules in those sockets.
- 1 Follow the safety guidelines listed in the Safety instructions section.
 - 2 Follow the procedure listed in the Before working inside your system section.
 - 3 If installed, remove the memory module or the memory-module blank.
 - 4 Remove the cooling shroud.

Steps

- 1 Locate the appropriate memory module socket.
 - ⚠ CAUTION:** Handle each memory module only by the card edges, ensuring not to touch the middle of the memory module or metallic contacts.
- 2 Open the ejectors on the memory module socket outward to allow the memory module to be inserted into the socket.
- 3 Align the edge connector of the memory module with the alignment key of the memory module socket, and insert the memory module in the socket.
 - ⚠ CAUTION:** Do not apply pressure at the center of the memory module; apply pressure at both ends of the memory module evenly.
 - ⓘ NOTE:** The memory module socket has an alignment key that enables you to install the memory module in the socket in only one orientation.
- 4 Press the memory module with your thumbs until the socket levers firmly click into place.

When the memory module is properly seated in the socket, the levers on the memory module socket align with the levers on the other sockets that have memory modules installed.

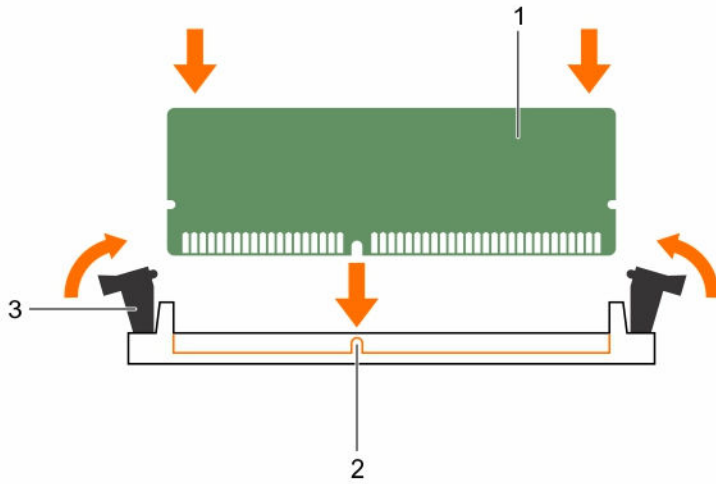

Figure 14. Installing the memory module

- | | | | |
|---|----------------------------------|---|---------------|
| 1 | memory module | 2 | alignment key |
| 3 | memory module socket ejector (2) | | |

Next steps

- 1 Install the cooling shroud.
- 2 Follow the procedure listed in the After working inside your system section.
- 3 Press F2 to enter System Setup, and check the **System Memory** setting.
The system should have already changed the value to reflect the installed memory.
- 4 If the value is incorrect, one or more of the memory modules may not be installed properly. Ensure that the memory module is firmly seated in the memory module socket.
- 5 Run the system memory test in system diagnostics.

Related links

- [Safety instructions](#)
- [Before working inside your system](#)
- [Removing the cooling shroud](#)
- [Installing the cooling shroud](#)
- [After working inside your system](#)
- [Removing memory modules](#)

PCIe mezzanine card

The sled supports one x8 PCIe Gen3 mezzanine card. The PCIe card provides an interface between the sled and external storage devices.

NOTE: Ensure that the PCIe mezzanine card is set to Enabled in System Setup.

NOTE: The PCIe mezzanine card slot is available for use only when CPU2 is installed.

Removing the PCIe mezzanine card

Prerequisites

CAUTION: Many repairs may only be done by a certified service technician. You should only perform troubleshooting and simple repairs as authorized in your product documentation, or as directed by the online or telephone service and support team. Damage due to servicing that is not authorized by Dell is not covered by your warranty. Read and follow the safety instructions that are shipped with your product.

- 1 Follow the safety guidelines listed in the Safety instructions section.
- 2 Follow the procedure listed in the Before working inside your system section.
- 3 If connected, disconnect all external storage devices.
- 4 If connected, disconnect all USB devices.
- 5 Remove the SSD cage.
- 6 Keep the Phillips #2 screwdriver ready.

Steps

- 1 To remove the SSD cage base cover:
 - a Place the SSD cage upside down with the USB ports to your right.
 - b Remove the screws securing the SSD cage base cover to the SSD cage.
 - c Slide the SSD cage base cover back and lift the cover away from the SSD cage.

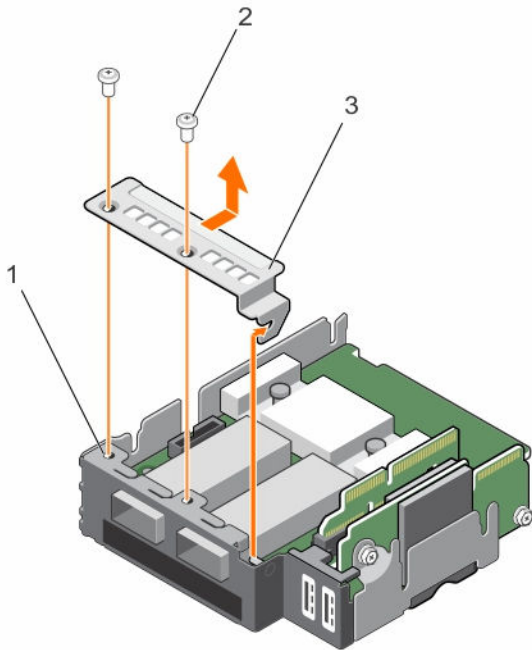

Figure 15. Removal of the SSD cage base cover

- 1 SSD cage
 - 2 screw (2)
 - 3 SSD cage base cover
- 2 To remove the PCIe mezzanine card:
 - a Remove the screws securing the PCIe mezzanine card to the SSD cage.
 - b Slide the mezzanine card back and lift the card away from the SSD cage.

- c Remove the PCIe mezzanine card bridge and keep it aside for future use.

CAUTION: To prevent damage to the PCIe mezzanine card, you must hold the card only by its edges.

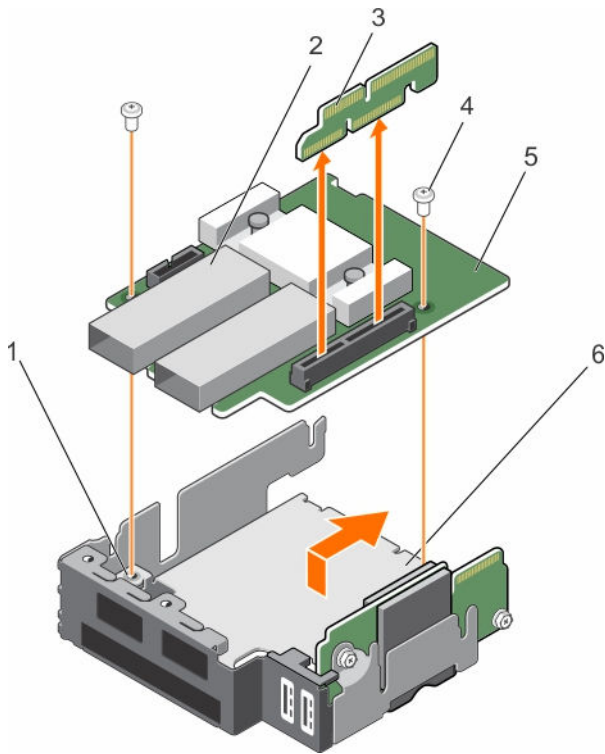

Figure 16. Removing a PCIe mezzanine card

- | | | | |
|---|----------------------------|---|--------------------------------|
| 1 | screw hole on SSD cage (2) | 2 | external storage connector (2) |
| 3 | PCIe mezzanine bridge card | 4 | Screw (2) |
| 5 | PCIe mezzanine card | 6 | SSD cage |

Next steps

- 1 Install the PCIe mezzanine card.
- 2 Install the SSD cage.
- 3 If applicable, reconnect the disconnected storage devices.
- 4 If applicable, reconnect the disconnected USB devices.
- 5 Follow the procedure listed in the After working inside your system section.

Related links

[Safety instructions](#)
[Before working inside your system](#)
[Removing the SSD cage](#)
[Installing the PCIe mezzanine card](#)
[Installing the SSD cage](#)
[After working inside your system](#)

Installing the PCIe mezzanine card

Prerequisites

⚠ CAUTION: Many repairs may only be done by a certified service technician. You should only perform troubleshooting and simple repairs as authorized in your product documentation, or as directed by the online or telephone service and support team. Damage due to servicing that is not authorized by Dell is not covered by your warranty. Read and follow the safety instructions that are shipped with your product.

ℹ NOTE: You must remove the PCIe mezzanine card to replace a faulty PCIe mezzanine card.

- 1 Follow the safety guidelines listed in the Safety instructions section.
- 2 Follow the procedure listed in the Before working inside your system section.
- 3 If connected, disconnect all external storage devices.
- 4 If connected, disconnect all USB devices.
- 5 Remove the SSD cage.
- 6 Remove the PCIe mezzanine card.
- 7 Keep the Phillips #2 screwdriver ready.

Steps

- 1 To install the PCIe mezzanine card:
 - a Place the SSD cage upside down with the USB ports to your right.
 - b Slide the PCIe mezzanine card on to the SSD cage.
 - c Secure the card in place with the screws.
 - d Install the PCIe mezzanine card bridge.

⚠ CAUTION: To prevent damage to the PCIe mezzanine card, you must hold the card only by its edges.

- 2 To install the SSD cage base cover :
 - a Slide the SSD cage base cover into place.
 - b Secure the SSD cage base cover to the SSD cage.
- 3 Align the guide slots on the SSD cage with the guide pins on the chassis.
- 4 Press down the SSD cage till the connectors on the SSD cage completely engage with the corresponding connectors on the system board.

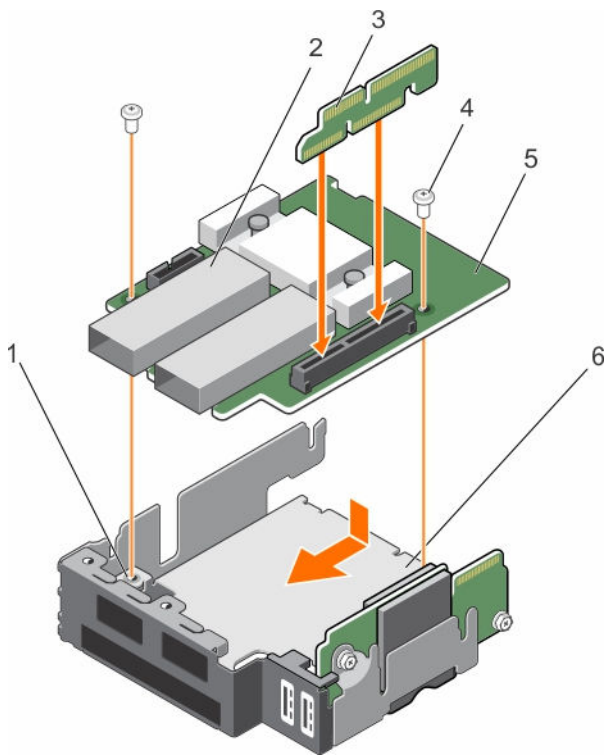

Figure 17. Installing the PCIe mezzanine card

- | | | | |
|---|----------------------------|---|--------------------------------|
| 1 | screw hole on SSD cage (2) | 2 | external storage connector (2) |
| 3 | PCIe mezzanine bridge card | 4 | Screw (2) |
| 5 | PCIe mezzanine card | 6 | SSD cage |

Next steps

- 1 Install the SSD cage.
- 2 If applicable, reconnect the disconnected storage devices.
- 3 If applicable, reconnect the disconnected USB devices.
- 4 Follow the procedure listed in the After working inside your system section.

Related links

- [Safety instructions](#)
- [Before working inside your system](#)
- [Removing the SSD cage](#)
- [Removing the PCIe mezzanine card](#)
- [Installing the SSD cage](#)
- [After working inside your system](#)

Internal Dual SD Module (IDSDM) card

The IDSDM card provides one SD card slot, one vFlash card slot, and a shared USB interface for the embedded hypervisor. This card offers the following features:

- Single card operation—single card operation is supported, but without redundancy.
- Dual card operation—dual card operation is supported and can be configured with redundancy.

NOTE: When the Redundancy option is set to Mirror Mode in the Integrated Devices screen of the System Setup, the information is replicated from one SD card to another.

Removing an internal SD card

Prerequisites

CAUTION: Many repairs may only be done by a certified service technician. You should only perform troubleshooting and simple repairs as authorized in your product documentation, or as directed by the online or telephone service and support team. Damage due to servicing that is not authorized by Dell is not covered by your warranty. Read and follow the safety instructions that are shipped with your product.

- 1 Follow the safety guidelines listed in the Safety instructions section.
- 2 Follow the procedure listed in the Before working inside your system section.
- 3 Enter System Setup and ensure that the **Internal SD Card Port** is enabled.

NOTE: When an SD card failure occurs, on the next reboot, the system displays a message indicating the failure.

Steps

- 1 Locate the SD card slot on the internal dual SD module (IDSDM) card.
- 2 Press the card to release it from the slot and remove the card.

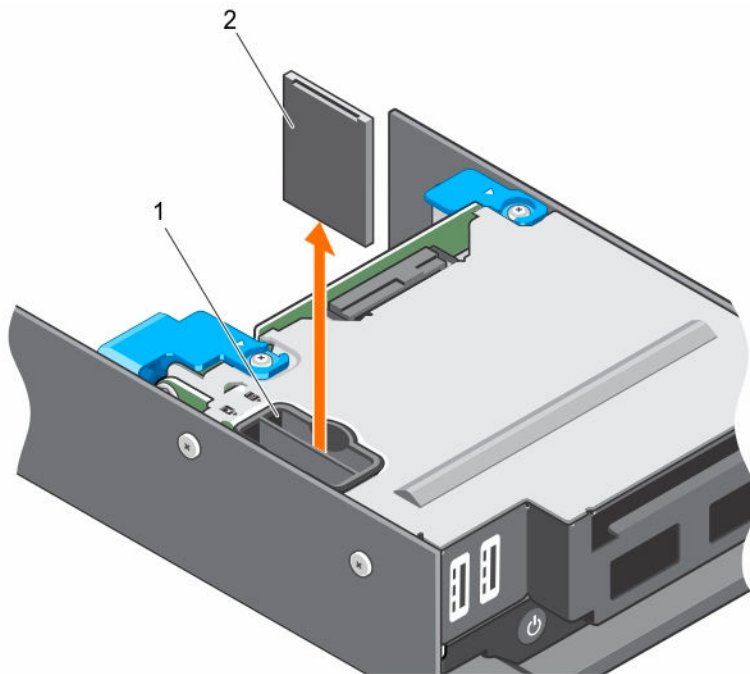

Figure 18. Replacing an internal SD card

1 SD card slot

2 SD card

Next steps

- 1 Follow the procedure listed in the After working inside your system section.
- 2 Enter System Setup and ensure that the **Internal SD Card Port** is enabled.
- 3 Check if the new SD card is functioning properly. If the problem persists, see the Troubleshooting an Internal SD Card section.

Related links

- [Safety instructions](#)
- [Before working inside your system](#)
- [After working inside your system](#)
- [Troubleshooting an internal SD card](#)
- [Installing an internal SD card](#)

Installing an internal SD card

Prerequisites

⚠ CAUTION: Many repairs may only be done by a certified service technician. You should only perform troubleshooting and simple repairs as authorized in your product documentation, or as directed by the online or telephone service and support team. Damage due to servicing that is not authorized by Dell is not covered by your warranty. Read and follow the safety instructions that are shipped with your product.

- 1 Follow the safety guidelines listed in the Safety instructions section.
- 2 Follow the procedure listed in the Before working inside your system section.
- 3 If applicable, remove the SD card.

ⓘ NOTE: To use an SD card with your system, ensure that the Internal SD Card Port is enabled in System Setup.

Steps

- 1 Locate the SD card connector on the internal dual SD module. Align the keyed end of the SD card into the slot and insert the card into the slot

ⓘ NOTE: The slot is keyed to ensure correct insertion of the card.

- 2 Press the card into the card slot to lock it into place.

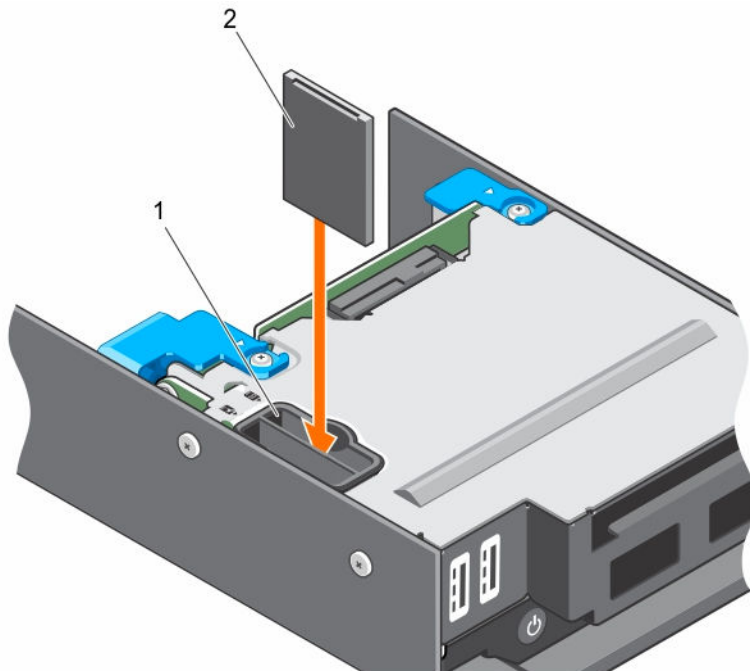

Figure 19. Installing an internal SD card

1 SD card slot

2 SD card

Next steps

- 1 Follow the procedure listed in the After working inside your system section.
- 2 Enter System Setup and ensure that the **Internal SD Card Port** is enabled.
- 3 Check if the new SD card is functioning properly. If the problem persists, see the Troubleshooting an Internal SD Card section.

Related links

- [Safety instructions](#)
- [Before working inside your system](#)
- [Removing an internal SD card](#)
- [After working inside your system](#)
- [Troubleshooting an internal SD card](#)

Removing the IDSDM card

Prerequisites

⚠ CAUTION: Many repairs may only be done by a certified service technician. You should only perform troubleshooting and simple repairs as authorized in your product documentation, or as directed by the online or telephone service and support team. Damage due to servicing that is not authorized by Dell is not covered by your warranty. Read and follow the safety instructions that came with the product.

- 1 Follow the safety guidelines listed in the Safety instructions section.
- 2 Follow the procedure listed in the Before working inside your system section.
- 3 If connected, disconnect all USB devices.
- 4 If installed, remove the SD card(s).
- 5 Remove the SSD cage.
- 6 Keep the Phillips #2 screwdriver ready.

Steps

- 1 Remove the screws securing the IDSDM card to the SSD cage.
- 2 Lift the IDSDM card till it disengages from the standoff and slide the IDSDM card away out of the SSD cage.

⚠ CAUTION: To prevent damage to the IDSDM card, you must hold the card only by its edges.

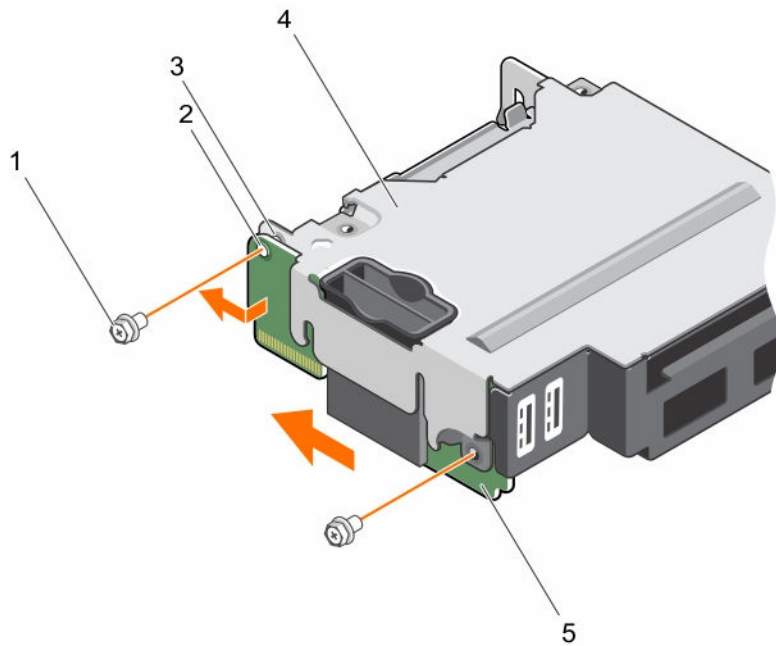

Figure 20. Removing the IDSDM card

- | | | | |
|---|--------------|---|----------------|
| 1 | screw (2) | 2 | screw hole (2) |
| 3 | standoff (1) | 4 | SSD cage |
| 5 | IDSDM card | | |

Next steps

- 1 Install the SSD cage.
- 2 Install the IDSDM card.
- 3 If applicable, install the SD cards.
- 4 Reconnect any disconnected USB devices.
- 5 Follow the procedure listed in the After working inside your system section.

Related links

- [Safety instructions](#)
- [Before working inside your system](#)
- [Removing an internal SD card](#)
- [Removing the SSD cage](#)
- [Installing the SSD cage](#)
- [Installing the IDSDM card](#)
- [Installing an internal SD card](#)
- [After working inside your system](#)

Installing the IDSDM card

Prerequisites

CAUTION: Many repairs may only be done by a certified service technician. You should only perform troubleshooting and simple repairs as authorized in your product documentation, or as directed by the online or telephone service and support team. Damage due to servicing that is not authorized by Dell is not covered by your warranty. Read and follow the safety instructions that came with the product.

NOTE: You must remove the IDSDM card to replace a faulty IDSDM card.

- 1 Follow the safety guidelines listed in the Safety instructions section.
- 2 Follow the procedure listed in the Before working inside your system section.
- 3 Remove the SD card.
- 4 Disconnect any connected USB devices.
- 5 Remove the SSD cage.
- 6 Remove the IDSDM card.
- 7 Keep the Phillips #2 screwdriver ready.

CAUTION: To prevent damage to the IDSDM card, you must hold the card only by its edges.

Steps

- 1 Slide the IDSDM card into the slot on the SSD cage.
- 2 Align the IDSDM card with the standoff on the SSD cage and the USB port slots on the front panel.
- 3 Secure the IDSDM card to the SSD cage with the screws.

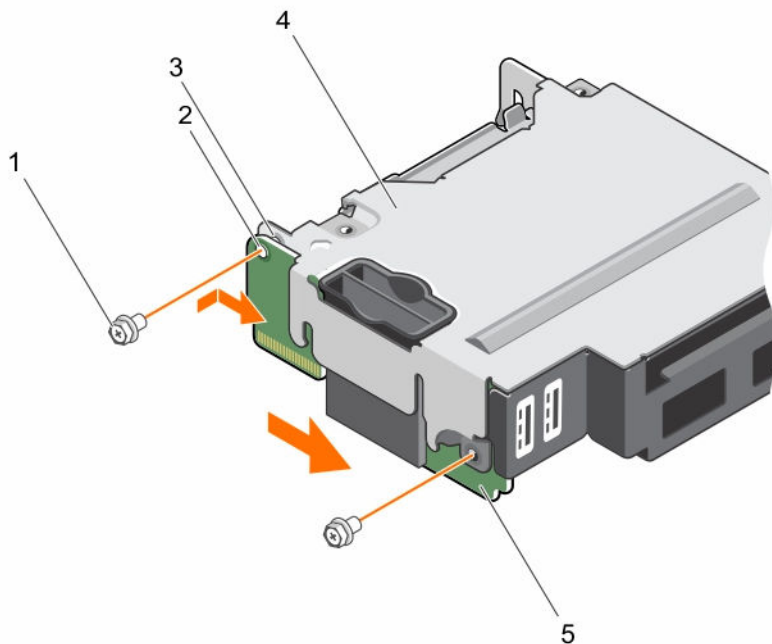

Figure 21. Installing the IDSDM card

- | | | | |
|---|--------------|---|----------------|
| 1 | screw (2) | 2 | screw hole (2) |
| 3 | standoff (1) | 4 | SSD cage |

Next steps

- 1 Install the SSD cage.
- 2 If applicable, install the SD card(s).
- 3 If applicable, reconnect any disconnected USB devices.
- 4 Follow the procedure listed in the After working inside your system section.

Related links

[Safety instructions](#)
[Before working inside your system](#)
[Removing an internal SD card](#)
[Removing the SSD cage](#)
[Removing the IDSDM card](#)
[Installing the SSD cage](#)
[Installing an internal SD card](#)
[After working inside your system](#)

SD vFlash card

A vFlash SD card is a Secure Digital (SD) card that plugs into the vFlash SD card slot in the system. It provides persistent on-demand local storage and a custom deployment environment that allows automation of server configuration, scripts, and imaging. It emulates USB devices. For more information, see the *Integrated Dell Remote Access Controller User's Guide* at Dell.com/idracmanuals.

You can use an SD vFlash card with your system. The card slot is on the IDSDM card. You can remove and install the SD vFlash card.

Replacing the SD vFlash card

Prerequisites

⚠ CAUTION: Many repairs may only be done by a certified service technician. You should only perform troubleshooting and simple repairs as authorized in your product documentation, or as directed by the online or telephone service and support team. Damage due to servicing that is not authorized by Dell is not covered by your warranty. Read and follow the safety instructions that came with the product.

- 1 Follow the safety guidelines listed in the Safety instructions section.
- 2 Follow the procedure listed in the Before working inside your system section.
- 3 If installed, remove the SD vFlash card from the card slot.

Steps

- 1 Insert the contact-pin end of the SD card into the card slot on the IDSDM card.

ⓘ NOTE: The slot is keyed to ensure correct insertion of the card.

- 2 Press the card into the card slot to lock it into place.

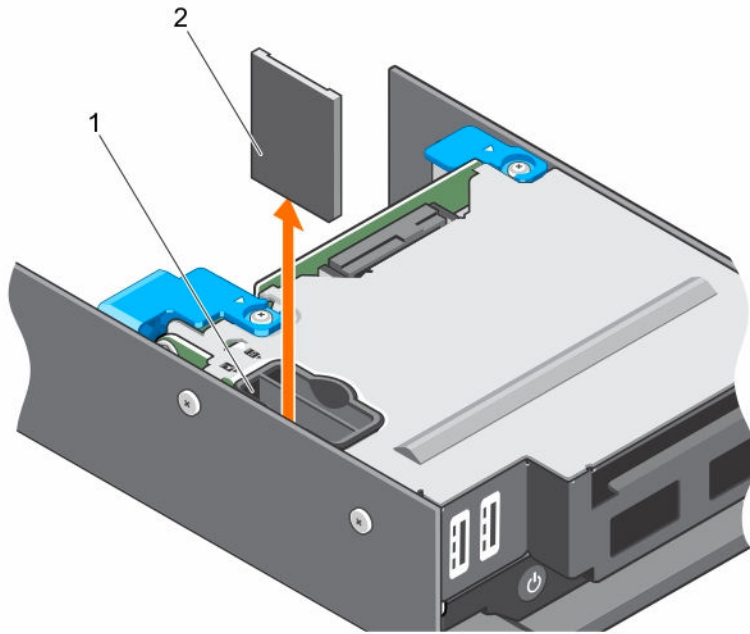

Figure 22. Replacing the SD vFlash card

1 SD vFlash slot

2 SD vFlash card

Next steps

Follow the procedure listed in the After working inside your system section.

Related links

- [Safety instructions](#)
- [Before working inside your system](#)
- [After working inside your system](#)
- [Installing the SD vFlash card](#)

Installing the SD vFlash card

Prerequisites

⚠ CAUTION: Many repairs may only be done by a certified service technician. You should only perform troubleshooting and simple repairs as authorized in your product documentation, or as directed by the online or telephone service and support team. Damage due to servicing that is not authorized by Dell is not covered by your warranty. Read and follow the safety instructions that are shipped with your product.

- 1 Follow the safety guidelines listed in the Safety instructions section.
- 2 Follow the procedure listed in the Before working inside your system section.

📌 NOTE: To use an SD card with your system, ensure that the Internal SD Card Port is enabled in System Setup.

Steps

- 1 Locate the SD card connector on the internal dual SD module. Align the SD card appropriately and insert the contact-pin end of the card into the slot.

📌 NOTE: The slot is keyed to ensure correct insertion of the card.

- 2 Press the card into the card slot to lock it into place.

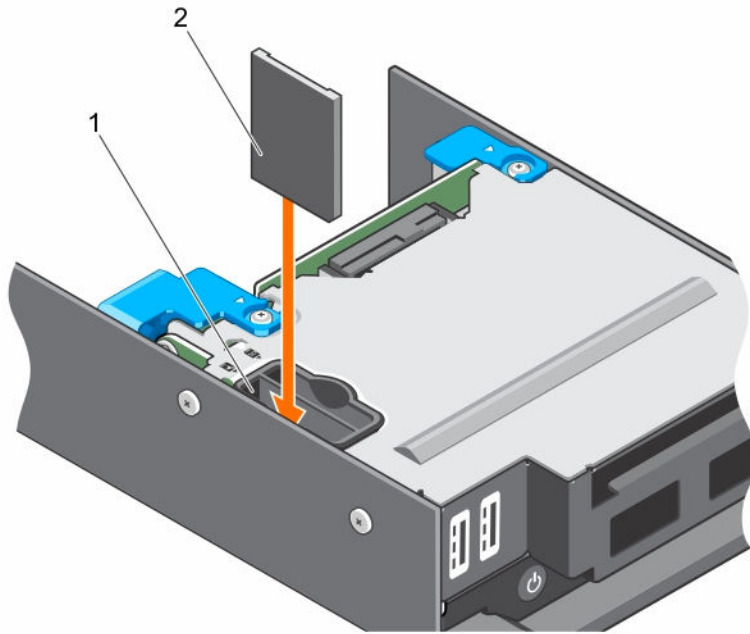

Figure 23. Installing the SD vFlash card

1 SD vFlash slot

2 SD vFlash card

Next steps

Follow the procedure listed in the After working inside your system section.

Related links

- [Safety instructions](#)
- [Before working inside your system](#)
- [After working inside your system](#)
- [Replacing the SD vFlash card](#)

LAN on Motherboard (LOM) riser card

The LOM riser card installed in your system is an integrated network interface controller. You can remove and install the LOM riser card.

Removing the LOM riser card

Prerequisites

CAUTION: Many repairs may only be done by a certified service technician. You should only perform troubleshooting and simple repairs as authorized in your product documentation, or as directed by the online or telephone service and support team. Damage due to servicing that is not authorized by Dell is not covered by your warranty. Read and follow the safety instructions that came with the product.

- 1 Follow the safety guidelines listed in the Safety instructions section.
- 2 Follow the procedure listed in the Before working inside your system section.
- 3 Keep the Phillips #2 screwdriver ready.

Steps

- 1 Remove the two screws that secure the LOM riser card to the system board.
- 2 Lift the card from the system board.

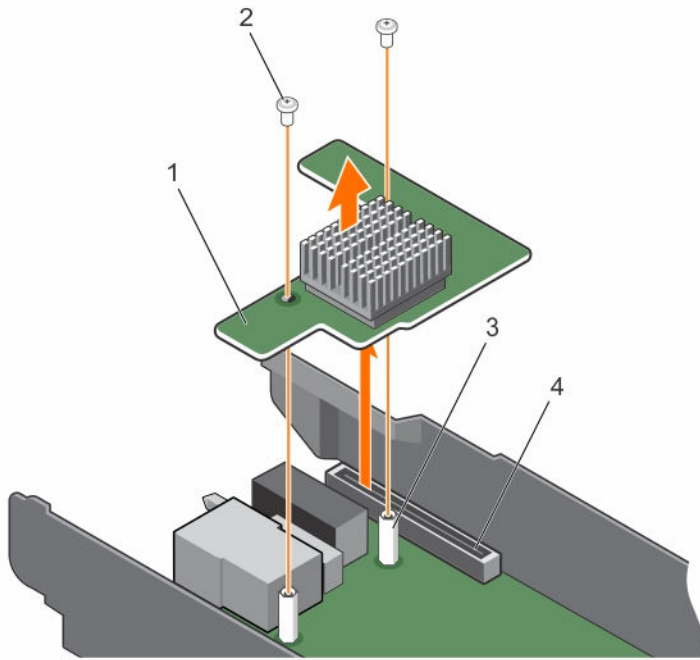

Figure 24. Removing the LOM riser card

- | | | | |
|---|----------------|---|-------------------------------|
| 1 | LOM riser card | 2 | screw (2) |
| 3 | standoff (2) | 4 | connector on the system board |

Next steps

- 1 Install the LOM riser card.
- 2 Follow the procedure listed in the After working inside your system section.

Related links

- [Safety instructions](#)
- [Before working inside your system](#)
- [Installing the LOM riser card](#)
- [After working inside your system](#)

Installing the LOM riser card

Prerequisites

⚠ CAUTION: Many repairs may only be done by a certified service technician. You should only perform troubleshooting and simple repairs as authorized in your product documentation, or as directed by the online or telephone service and support team. Damage due to servicing that is not authorized by Dell is not covered by your warranty. Read and follow the safety instructions that came with the product.

📄 NOTE: You must remove the LOM riser card to replace a faulty LOM riser card or service other components inside the system.

- 1 Follow the safety guidelines listed in the Safety instructions section.
- 2 Follow the procedure listed in the Before working inside your system section.
- 3 Keep the Phillips #2 screwdriver ready.

Steps

1 Align the screw holes on the card with the standoffs on the system board.

⚠ CAUTION: To prevent damage to the LOM riser card, you must hold the card only by its edges.

2 Press the card into place until the card connector fits into the corresponding connector on the system board.

3 Secure the card with the two screws.

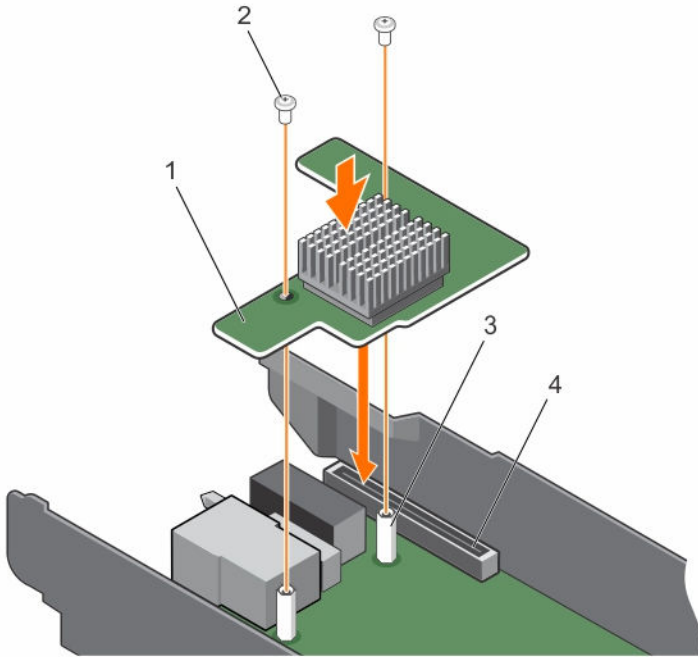

Figure 25. Installing the LOM riser card

1 LOM riser card

2 screw (2)

3 standoff (2)

4 connector on the system board

Next steps

Follow the procedure listed in the After working inside your system section.

Related links

[Safety instructions](#)

[Before working inside your system](#)

[After working inside your system](#)

[Removing the LOM riser card](#)

Processors

The CPU contains memory, peripheral interfaces, and other components of the system.

Your system supports up to two Intel Haswell EP product family processors or Broadwell-EP 2S product family processors.

ⓘ NOTE: The sled supports the following processors:

- Up to two 120 W processors are supported.
- A single 140 W processor is supported.

ⓘ NOTE: Mixing processors of different wattages is not supported.

Use the following procedure when:

- Installing an additional processor.
- Replacing a processor.

Removing a heat sink

Prerequisites

⚠ CAUTION: Many repairs may only be done by a certified service technician. You should only perform troubleshooting and simple repairs as authorized in your product documentation, or as directed by the online or telephone service and support team. Damage due to servicing that is not authorized by Dell is not covered by your warranty. Read and follow the safety instructions that are shipped with your product.

⚠ CAUTION: Never remove the heat sink from a processor unless you intend to remove the processor. The heat sink is necessary to maintain proper thermal conditions.

ℹ NOTE: This is a Field Replaceable Unit (FRU). Removal and installation procedures should be performed only by Dell certified service technicians.

ℹ NOTE: To ensure proper system cooling, you must install a processor blank in any empty processor socket.

- 1 Follow the safety guidelines listed in the Safety instructions section.
- 2 Follow the procedure listed in the Before working inside your system section.
- 3 Remove the cooling shroud.
- 4 Keep the Phillips #2 screwdriver ready.

⚠ WARNING: The heat sink will be hot to touch for some time after the system has been powered down. Allow the heat sink to cool before removing it.

Steps

- 1 To remove a 120 W heat sink, perform the following steps.
 - a Loosen one of the screws that secure the heat sink to the system board.
Wait 30 seconds for the heat sink to loosen from the processor.
 - b Remove the screw diagonally opposite the screw you first removed.
 - c Repeat the procedure for the remaining two screws.

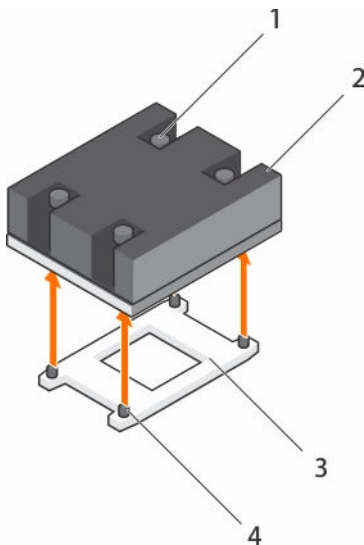

Figure 26. Removing the 120 W heat sink

1 captive screw (4)

2 heat sink

3 processor socket

4 screw hole (4)

- 2 To remove a 140 W heat sink, perform the following steps.
 - a Loosen one of the screws that secure the heat sink over CPU 1 to the system board.
Wait 30 seconds for the heat sink to loosen from the processor.
 - b Remove the screw diagonally opposite the screw you first removed.
 - c Repeat the procedure for the remaining four screws.

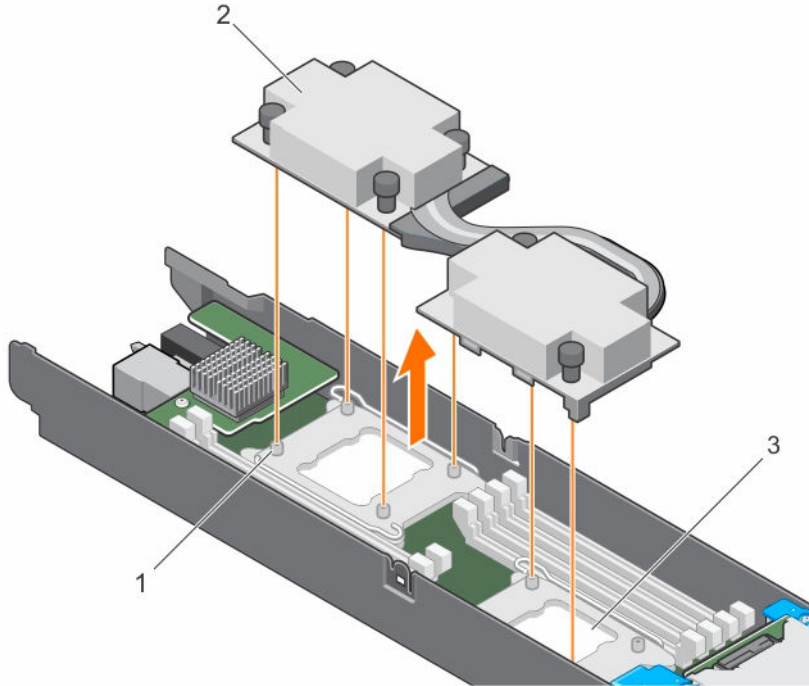

Figure 27. Removing the 140 W heat sink

1 screw hole (6)

2 heat sink

3 processor socket (2)

Next steps

- 1 Remove the processor.
- 2 Follow the procedure listed in the After working inside your system section.

Related links

[Safety instructions](#)
[Before working inside your system](#)
[Removing the cooling shroud](#)
[Removing a processor](#)
[After working inside your system](#)
[Installing a heat sink](#)

Removing a processor

Prerequisites

⚠ WARNING: The processor is hot to touch for some time after the system has been powered down. Allow the processor to cool before removing it.

⚠ CAUTION: Many repairs may only be done by a certified service technician. You should only perform troubleshooting and simple repairs as authorized in your product documentation, or as directed by the online or telephone service and support team. Damage due to servicing that is not authorized by Dell is not covered by your warranty. Read and follow the safety instructions that are shipped with your product.

⚠ CAUTION: The processor is held in its socket under strong pressure. Be aware that the release lever can spring up suddenly if not firmly grasped.

ℹ NOTE: This is a Field Replaceable Unit (FRU). Removal and installation procedures should be performed only by Dell certified service technicians.

ℹ NOTE: To ensure proper system cooling, you must install a processor blank in any empty processor socket.

- 1 Follow the safety guidelines listed in the Safety instructions section.
- 2 Follow the procedure listed in the Before working inside your system section.
- 3 If you are upgrading your system (from a single processor system to a dual processor system or a processor with a higher processor bin), download the latest system BIOS version from **Dell.com/support** and follow the instructions included in the compressed download file to install the update on your system.
- 4 Remove the cooling shroud.
- 5 Remove the heat sink.
- 6 Keep the Phillips #2 screwdriver ready.

Steps

- 1 Using a clean, lint-free cloth remove any thermal grease from the surface of the processor shield.

⚠ CAUTION: The processor is held in its socket under strong pressure. Be aware that the release lever can spring up suddenly if not firmly grasped.

- 2 Position your thumb firmly over the socket-release lever 1 and lever 2 of the processor and release both the levers simultaneously from the locked position by pushing down and out from under the tab.

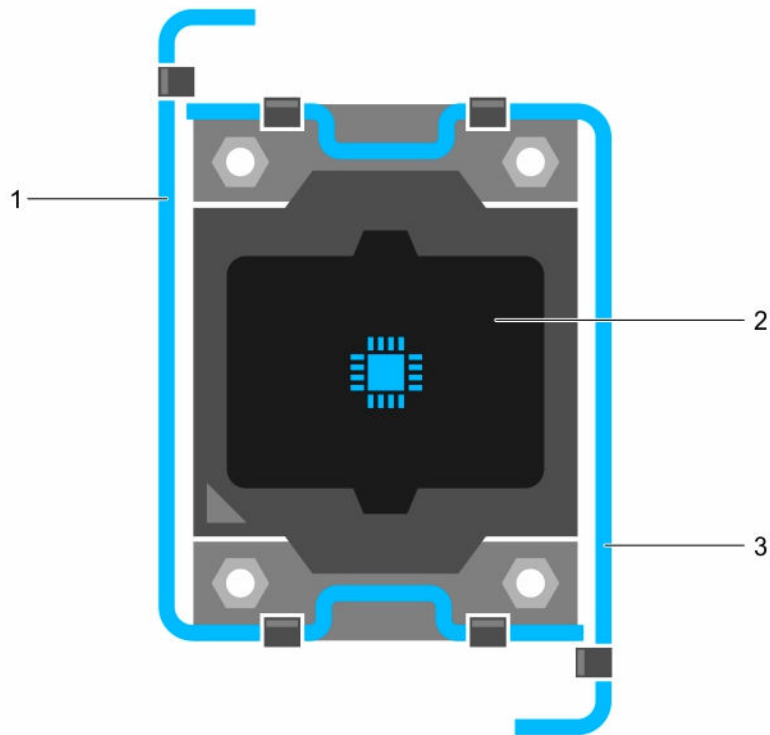

Figure 28. Processor shield opening and closing lever sequence

- 1 socket-release lever 1
- 2 processor
- 3 socket-release lever 2

- 3 Hold the tab on the processor shield and rotate the shield upward and out of the way.
- 4 Lift the processor out of the socket and leave the release lever up so that the socket is ready for the new processor.

CAUTION: If you are permanently removing a processor, you must install a socket protective cap and a processor blank in the vacant socket to ensure proper system cooling. The processor blank covers the vacant sockets for the DIMMs and the processor.

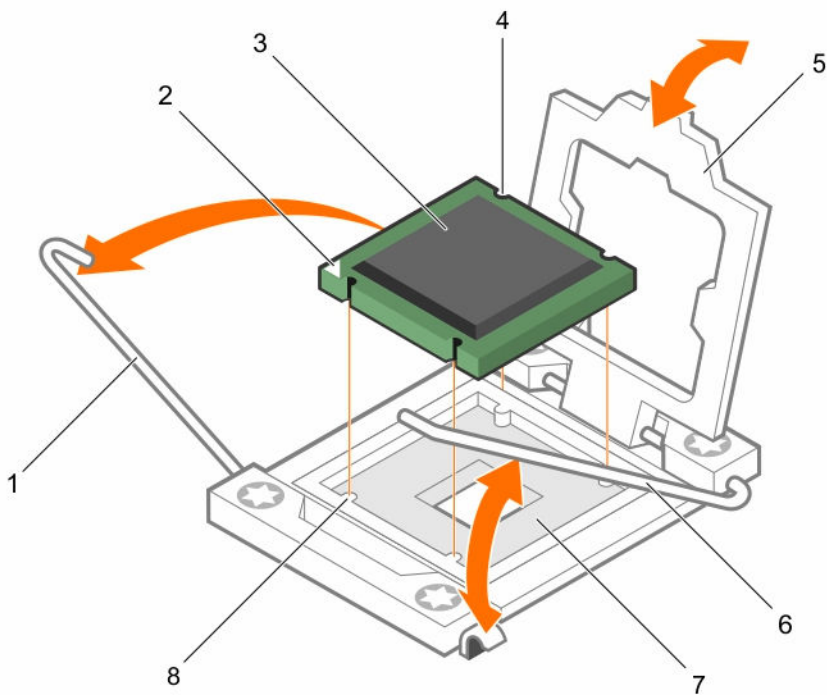

Figure 29. Removing a processor

- | | | | |
|---|------------------------|---|-------------------------------|
| 1 | socket-release lever 1 | 2 | pin-1 corner of the processor |
| 3 | processor | 4 | slot (4) |
| 5 | processor shield | 6 | socket-release lever 2 |
| 7 | processor socket | 8 | tab (4) |

Next steps

- 1 If you are removing the processor permanently, install the processor blank.
- 2 Install a processor.
- 3 Install the heat sink.
- 4 Follow the procedure listed in the After working inside your system section.

Related links

- [Safety instructions](#)
- [Before working inside your system](#)
- [Removing the cooling shroud](#)
- [Installing a processor](#)
- [Installing a processor blank and DIMM blank](#)
- [Installing a heat sink](#)
- [After working inside your system](#)

Installing a processor

Prerequisites

⚠ CAUTION: Many repairs may only be done by a certified service technician. You should only perform troubleshooting and simple repairs as authorized in your product documentation, or as directed by the online or telephone service and support team. Damage due to servicing that is not authorized by Dell is not covered by your warranty. Read and follow the safety instructions that are shipped with your product.

ℹ NOTE: This is a Field Replaceable Unit (FRU). Removal and installation procedures should be performed only by Dell certified service technicians.

ℹ NOTE: If you are installing just one processor, it must be installed in socket CPU1.

- 1 Follow the safety guidelines listed in the Safety instructions section.
- 2 Follow the procedure listed in the Before working inside your system section.
- 3 Remove the processor or processor blank or DIMM blank.
- 4 If you are upgrading your system (from a single processor system to a dual processor system or a processor with a higher processor bin) download the latest system BIOS version from [Dell.com/support](https://www.dell.com/support) and follow the instructions included in the compressed download file to install the update on your system.

ℹ NOTE: You can update the system BIOS by using Lifecycle Controller.

⚠ WARNING: The heat sink and processor are too hot to the touch for some time after the system has been powered down. Allow the heat sink and processor to cool down before handling them.

⚠ CAUTION: Never remove the heat sink from a processor unless you intend to remove the processor. The heat sink is necessary to maintain proper thermal conditions.

Steps

- 1 Unpack the new processor.
- 2 Locate the processor socket.
- 3 Unlatch and rotate the socket-release levers 90 degrees upward and ensure that the socket-release lever is fully open.
- 4 Hold the tab on the processor shield and rotate the shield upward and out of the way.

ℹ NOTE: Dell recommends that you install or remove the socket protective cap from the processor shield with the processor shield in the open position.

- 5 If installed, remove the socket protective cap from the processor shield. To remove the socket protective cap, push the cap from the inside of the processor shield and move it away from the socket pins.

⚠ CAUTION: Positioning the processor incorrectly can permanently damage the system board or the processor. Be careful not to bend the pins in the socket.

⚠ CAUTION: Do not use force to seat the processor. When the processor is positioned correctly, it engages easily into the socket.

- 6 Install the processor in the socket:
 - a Identify the pin-1 corner of the processor by locating the tiny gold triangle on one corner of the processor. Place this corner in the same corner of the ZIF (Zero Insertion Force) socket identified by a corresponding triangle on the system board.
 - b Align the pin-1 corner of the processor with the pin-1 corner of the system board.
 - c Set the processor lightly in the socket.

Because the system uses a ZIF processor socket, do not use force. When the processor is positioned correctly, it drops down into the socket with minimal pressure.
 - d Close the processor shield.
 - e Rotate the socket-release lever 1 and lever 2 simultaneously until it is locked in position.

Next steps

NOTE: Ensure that you install the heat sink after you install the processor. The heat sink is necessary to maintain proper thermal conditions.

- 1 Install the heat sink.
- 2 If you are permanently removing the processor and the heat sink, ensure that you install a processor/DIMM blank.
- 3 Follow the procedure listed in the After working inside your system section.

Related links

- [Safety instructions](#)
- [Before working inside your system](#)
- [Removing a processor blank and DIMM blank](#)
- [Installing a heat sink](#)
- [After working inside your system](#)
- [Removing a processor](#)

Installing a heat sink

Prerequisites

CAUTION: Many repairs may only be done by a certified service technician. You should only perform troubleshooting and simple repairs as authorized in your product documentation, or as directed by the online or telephone service and support team. Damage due to servicing that is not authorized by Dell is not covered by your warranty. Read and follow the safety instructions that are shipped with your product.

NOTE: This is a Field Replaceable Unit (FRU). Removal and installation procedures should be performed only by Dell certified service technicians.

- 1 Follow the safety guidelines listed in the Safety instructions section.
- 2 Follow the procedure listed in the Before working inside your system section.
- 3 Keep the Phillips #2 screwdriver ready.
- 4 Install the processor.

Steps

- 1 If you are using an existing heat sink, remove the thermal grease from the heat sink by using a clean lint-free cloth.
- 2 Use the thermal grease syringe included with your processor kit to apply the grease in a thin spiral on the top of the processor.

CAUTION: Applying too much thermal grease can result in excess grease coming in contact with and contaminating the processor socket.

NOTE: The thermal grease syringe is intended for one-time use only. Dispose of the syringe after you use it.

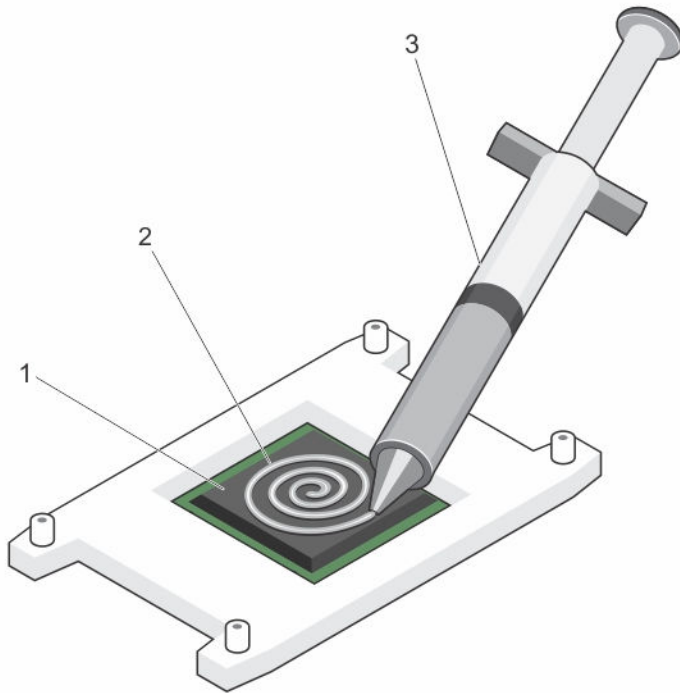

Figure 30. Applying thermal grease on the top of the processor

- | | | | |
|---|------------------------|---|----------------|
| 1 | processor | 2 | thermal grease |
| 3 | thermal grease syringe | | |

- 3 Place the heat sink onto the processor.
- 4 Tighten one of the four screws to secure the heat sink to the system board.
- 5 Tighten the screw diagonally opposite to the first screw you have tightened.

NOTE: Do not over-tighten the heat sink retention screws when installing the heat sink. To prevent over-tightening, tighten the retention screw until resistance is felt, and stop after the screw is seated. The screw tension should not be more than 6 in-lb (6.9 kg-cm).

- 6 Repeat the procedure for the remaining two screws.

Next steps

- 1 Follow the procedure listed in the After working inside your system section.
- 2 While booting, press F2 to enter System Setup and verify that the processor information matches the new system configuration.
- 3 Run the system diagnostics to verify that the new processor operates correctly.

Processor blank and DIMM blank

The processor blank and DIMM blank supplied with your system aids in directing airflow over the unused processor sockets and DIMM slots.

CAUTION: If you are permanently removing a processor, you must install a socket protective cap and a processor blank and DIMM blank in the vacant socket to ensure proper system cooling. The processor blank and DIMM blank covers the vacant sockets for the DIMMs and the processor.

Removing a processor blank and DIMM blank

Prerequisites

CAUTION: Many repairs may only be done by a certified service technician. You should only perform troubleshooting and simple repairs as authorized in your product documentation, or as directed by the online or telephone service and support team. Damage due to servicing that is not authorized by Dell is not covered by your warranty. Read and follow the safety instructions that came with the product.

NOTE: You must remove processor blank and DIMM blank when installing four processors or service other components inside the system.

- 1 Follow the safety guidelines listed in the Safety instructions section.
- 2 Follow the procedure listed in the Before working inside your system section.
- 3 Remove the cooling shroud.

Steps

Hold the processor blank and DIMM blank by its edges and lift it away from the system.

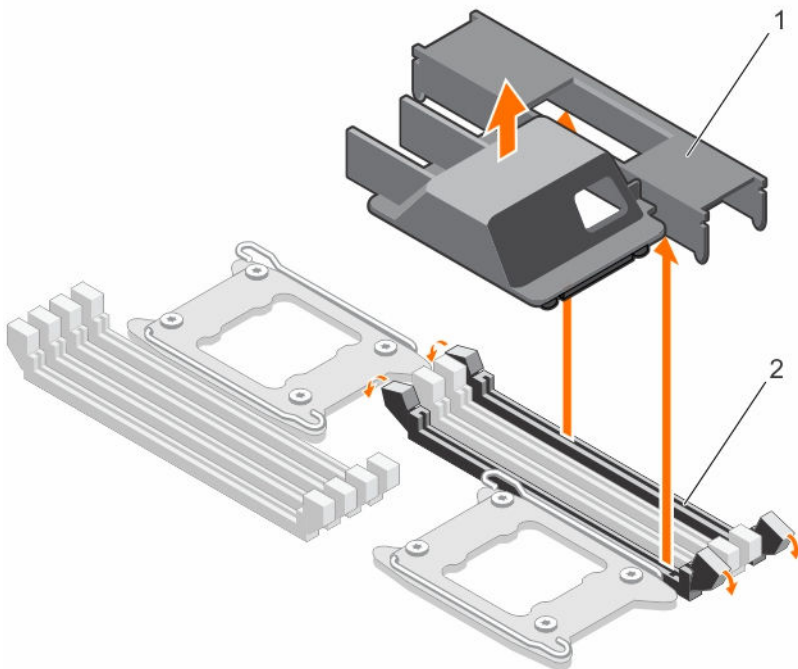

Figure 31. Removing a processor blank and DIMM blank

1 processor blank and DIMM blank

2 memory module socket (2)

Next steps

- 1 Install the processor and the heat sink.
- 2 Install the cooling shroud.
- 3 If you are removing a processor permanently, install the processor blank and DIMM blank.
- 4 Follow the procedure listed in the After working inside your system section.

Related links

- [Safety instructions](#)
- [Before working inside your system](#)
- [After working inside your system](#)
- [Installing a processor blank and DIMM blank](#)

Installing a processor blank and DIMM blank

Prerequisites

⚠ CAUTION: Many repairs may only be done by a certified service technician. You should only perform troubleshooting and simple repairs as authorized in your product documentation, or as directed by the online or telephone service and support team. Damage due to servicing that is not authorized by Dell is not covered by your warranty. Read and follow the safety instructions that came with the product.

📘 NOTE: You must remove the processor-and-DIMM blank when using a dual processor configuration or to service other components inside the system.

- 1 Follow the safety guidelines listed in the Safety instructions section.
- 2 Follow the procedure listed in the Before working inside your system section.
- 3 Remove the cooling shroud.

Steps

- 1 Align the standoffs on the processor blank and DIMM blank with the heat sink retention sockets on the processor socket.
- 2 Lower the processor blank and DIMM blank onto the system until the standoffs on the processor blank and DIMM blank engage with the heat sink retention sockets.

Next steps

- 1 Ensure that you install a processor blank and DIMM blank when you have removed a processor permanently.
- 2 Install the cooling shroud.
- 3 Follow the procedure listed in the After working inside your system section.

Related links

- [Safety instructions](#)
- [Before working inside your system](#)
- [After working inside your system](#)
- [Removing a processor blank and DIMM blank](#)

Solid State Drives (SSD)

The PowerEdge FC430 system supports up to two 1.8 inch-uSATA SSDs. The SSDs are supplied in special hot swap drive carriers that fit in the drive bays and these drives connect to the system board through the SSD backplane board.

SSD installation guidelines

In a dual SSD bay sled that has a single SSD installed, an SSD blank must be installed in the vacant drive bay to maintain proper airflow.

Shutdown procedure for servicing an SSD

📘 NOTE: This section applies only to situations where the sled must be turned off to service an SSD.

If you need to service an SSD, turn off the sled and before removing the SSD wait for 30 seconds after the Power-on indicator on the sled turns off. Otherwise, the SSD may not be recognized after it is reinstalled and the sled is turned on again.

Removing an SSD from an SSD carrier

Prerequisites

CAUTION: Many repairs may only be done by a certified service technician. You should only perform troubleshooting and simple repairs as authorized in your product documentation, or as directed by the online or telephone service and support team. Damage due to servicing that is not authorized by Dell is not covered by your warranty. Read and follow the safety instructions that came with the product.

- 1 Follow the safety guidelines listed in the Safety instructions section.
- 2 Remove the SSD carrier out of the sled.

Steps

Pull the rails on the side of the carrier and lift the SSD out of the carrier.

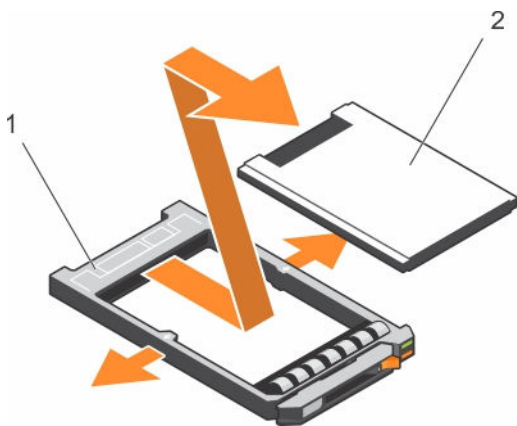

Figure 32. Removing an SSD in an SSD carrier

- | | | | |
|---|-------------|---|-----|
| 1 | SSD carrier | 2 | SSD |
|---|-------------|---|-----|

Next steps

- 1 Install an SSD in the SSD carrier.
- 2 Install the SSD carrier into the sled.

Related links

- [Safety instructions](#)
- [Before working inside your system](#)
- [Removing an SSD carrier](#)
- [Installing an SSD into an SSD carrier](#)
- [After working inside your system](#)

Installing an SSD into an SSD carrier

Prerequisites

⚠ CAUTION: Many repairs may only be done by a certified service technician. You should only perform troubleshooting and simple repairs as authorized in your product documentation, or as directed by the online or telephone service and support team. Damage due to servicing that is not authorized by Dell is not covered by your warranty. Read and follow the safety instructions that came with the product.

ℹ NOTE: You must remove the SSD from the SSD carrier to replace a faulty SSD from an SSD carrier.

- 1 Follow the safety guidelines listed in the Safety instructions section.
- 2 Remove the SSD carrier out of the sled.
- 3 Remove the SSD from the SSD carrier.

Steps

Insert the SSD into the SSD carrier with the connector end of the SSD toward the back of the carrier. When the SSD is aligned correctly, the back of the SSD is flush with the back of the SSD carrier.

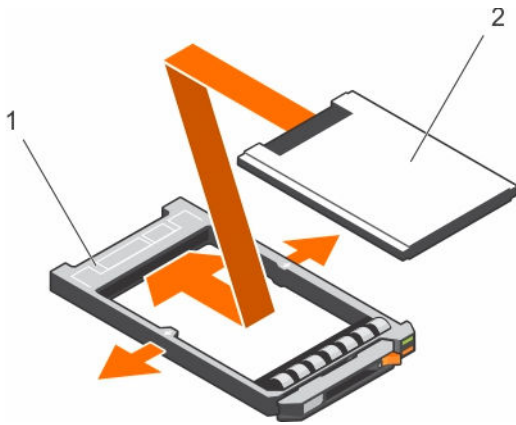

Figure 33. Installing an SSD into an SSD carrier

1 SSD carrier

2 SSD

Next steps

- 1 Install the SSD carrier into the sled.
- 2 Follow the procedure listed in the After working inside your system section.

Related links

- [Safety instructions](#)
- [Before working inside your system](#)
- [Removing an SSD carrier](#)
- [Removing an SSD from an SSD carrier](#)
- [Installing an SSD carrier](#)
- [After working inside your system](#)

Removing an SSD carrier

Prerequisites

⚠ CAUTION: Many repairs may only be done by a certified service technician. You should only perform troubleshooting and simple repairs as authorized in your product documentation, or as directed by the online or telephone service and support team. Damage due to servicing that is not authorized by Dell is not covered by your warranty. Read and follow the safety instructions that came with the product.

- 1 Follow the safety guidelines listed in the Safety instructions section.
- 2 Turn off the sled and wait until the SSD indicator LEDs on the carrier are off, and then remove the SSD.

📌 NOTE: When all indicators are off, the drive is ready for removal.

📌 NOTE: All operating systems do not support hot-swappable drive installation. See the documentation supplied with your operating system.

Steps

- 1 Press the release button to open the SSD carrier handle.
- 2 Slide the SSD carrier out until it is free of the SSD slot.

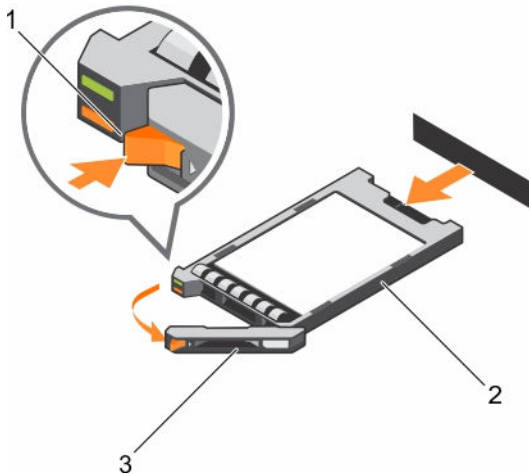

Figure 34. Removing an SSD carrier

- | | | | |
|---|--------------------|---|--------------------|
| 1 | release button | 2 | SSD in the carrier |
| 3 | SSD carrier handle | | |

Next steps

- 1 If you are removing an SSD permanently, install the SSD blank. If you are installing a new SSD, see the Installing an SSD section.
- 2 Follow the procedure listed in the After working inside your system section.

Related links

- [Safety instructions](#)
- [Before working inside your system](#)
- [Installing an SSD carrier](#)
- [After working inside your system](#)

Installing an SSD carrier

Prerequisites

CAUTION: When a replacement hot swappable SSD is installed and the sled is powered on, the SSD automatically begins to rebuild. Make absolutely sure that the replacement SSD is blank or contains data that you wish to have over-written. Any data on the replacement SSD is immediately lost after the SSD is installed.

NOTE: You must remove an SSD to upgrade an SSD or replace a faulty SSD.

- 1 Follow the safety guidelines listed in the Safety instructions section.
- 2 Remove the SSD blank.
- 3 Install the SSD in the SSD carrier.

NOTE: All operating systems do not support hot swappable drive installation. See the documentation supplied with your operating system.

Steps

- 1 Press the release button to open the SSD carrier handle.
 - 2 Slide the SSD carrier into the drive bay and push it until the handle makes contact with the sled.
 - 3 Rotate the carrier handle to the closed position while pushing the carrier into the slot until it locks into place.
- The status LED indicator displays a steady green light if the drive is installed correctly. The drive carrier LED green indicator flashes as the drive rebuilds.

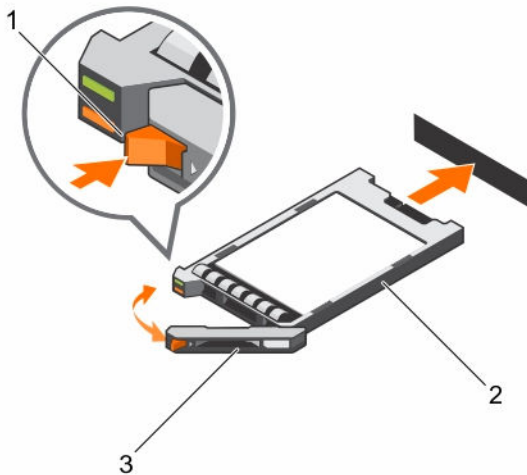

Figure 35. Installing an SSD carrier

- | | | | |
|---|--------------------|---|--------------------|
| 1 | release button | 2 | SSD in the carrier |
| 3 | SSD carrier handle | | |

Next steps

Follow the procedure listed in the After working inside your system section.

Related links

- [Safety instructions](#)
- [Before working inside your system](#)
- [Removing an SSD blank](#)
- [Installing an SSD into an SSD carrier](#)
- [After working inside your system](#)
- [Removing an SSD carrier](#)

Removing an SSD blank

Prerequisites

CAUTION: Many repairs may only be done by a certified service technician. You should only perform troubleshooting and simple repairs as authorized in your product documentation, or as directed by the online or telephone service and support team. Damage due to servicing that is not authorized by Dell is not covered by your warranty. Read and follow the safety instructions that came with the product.

CAUTION: To maintain proper system cooling, all empty SSD slots must have a SSD blank installed.

Follow the safety guidelines listed in the Safety instructions section.

Steps

Press the release latch and slide the SSD blank out of the SSD slot.

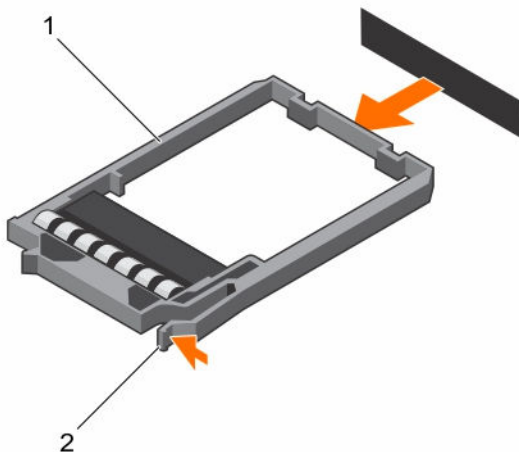

Figure 36. Removing an SSD blank

1 SSD blank

2 release latch

Next steps

Install the SSD

Related links

- [Safety instructions](#)
- [Before working inside your system](#)
- [Installing an SSD carrier](#)
- [After working inside your system](#)
- [Installing an SSD blank](#)

Installing an SSD blank

Prerequisites

- 1 Follow the safety guidelines listed in the Safety instructions section.
- 2 Remove the SSD.

Steps

Insert the SSD blank into the SSD slot until the release latch clicks into place.

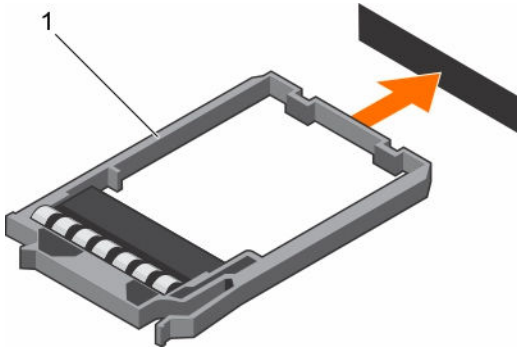

Figure 37. Installing an SSD blank

- 1 SSD blank

Next steps

Follow the procedure listed in the After working inside your system section.

Related links

- [Safety instructions](#)
- [Before working inside your system](#)
- [Removing an SSD carrier](#)
- [After working inside your system](#)
- [Installing an SSD blank](#)

Removing the SSD cage

Prerequisites

⚠ CAUTION: Many repairs may only be done by a certified service technician. You should only perform troubleshooting and simple repairs as authorized in your product documentation, or as directed by the online or telephone service and support team. Damage due to servicing that is not authorized by Dell is not covered by your warranty. Read and follow the safety instructions that came with the product.

- 1 Follow the safety guidelines listed in the Safety instructions section.
- 2 Follow the procedure listed in the Before working inside your system section.
- 3 Remove the SSD(s).
- 4 Disconnect all connected USB devices.
- 5 Keep the Phillips #1 screwdriver ready.

Steps

- 1 Remove the four screws securing the SSD cage to the chassis.
- 2 Holding the SSD cage by its edges, lift it away from the sled.

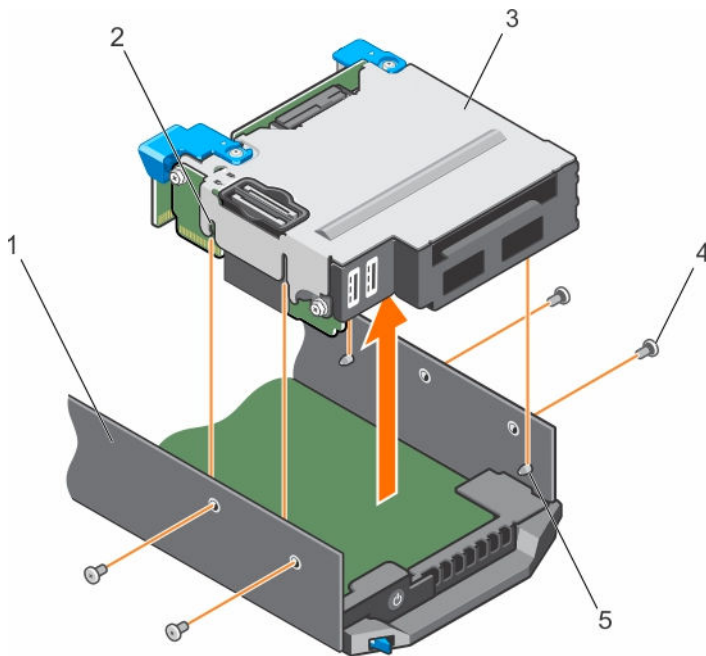

Figure 38. Removing an SSD cage

- | | | | |
|---|---------------|---|--------------------|
| 1 | chassis | 2 | guide pin slot (4) |
| 3 | SSD cage | 4 | screw (4) |
| 5 | guide pin (4) | | |

Next steps

- 1 Install the SSD cage.
- 2 Install the SSD(s).
- 3 Reconnect the USB devices.
- 4 Follow the procedure listed in the After working inside your system section.

Related links

- [Safety instructions](#)
- [Before working inside your system](#)
- [Removing an SSD carrier](#)
- [Installing the SSD cage](#)
- [After working inside your system](#)

Installing the SSD cage

Prerequisites

- ⚠ CAUTION:** Many repairs may only be done by a certified service technician. You should only perform troubleshooting and simple repairs as authorized in your product documentation, or as directed by the online or telephone service and support team. Damage due to servicing that is not authorized by Dell is not covered by your warranty. Read and follow the safety instructions that came with the product.

NOTE: You must remove the SSD cage to replace a faulty SSD cage or service other components inside the system.

- 1 Follow the safety guidelines listed in the Safety instructions section.
- 2 Follow the procedure listed in the Before working inside your system section.
- 3 Keep the Phillips #1 screwdriver ready.

Steps

- 1 Align the slots on the sides of the SSD cage with the guide pins on the chassis.
- 2 Push the SSD cage into the chassis until the screw holes on the chassis are aligned with the holes on the SSD cage.
- 3 Slide the SSD cage into the chassis till the IDSDM card connector engages completely with the connector on the system board.
- 4 Secure the SSD cage to the chassis with the screws.

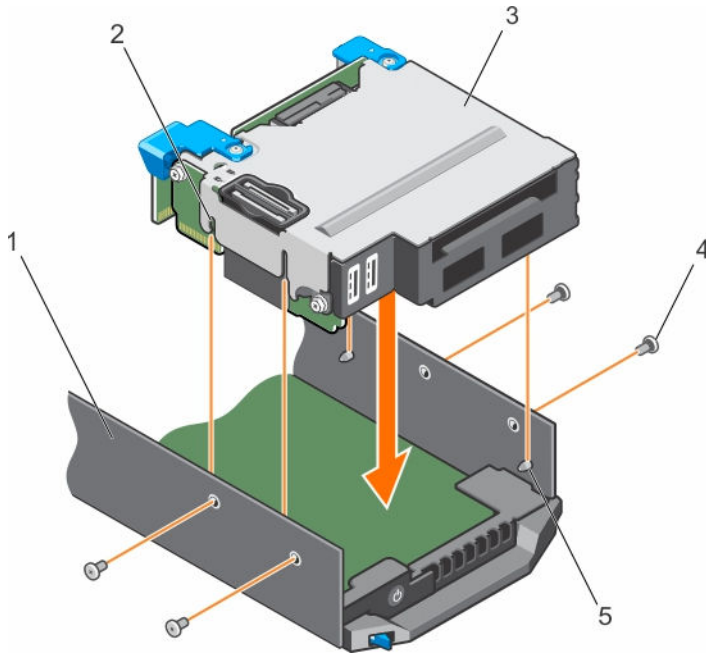

Figure 39. Installing the SSD cage

- | | | | |
|---|---------------|---|--------------------|
| 1 | chassis | 2 | guide pin slot (4) |
| 3 | SSD cage | 4 | screw (4) |
| 5 | guide pin (4) | | |

Next steps

- 1 Install the SSD backplane.
- 2 Install the SSDs.
- 3 Follow the procedure listed in the After working inside your system section.

Related links

- [Safety instructions](#)
- [Before working inside your system](#)
- [Installing the SSD backplane](#)
- [Installing an SSD carrier](#)
- [After working inside your system](#)
- [Removing the SSD cage](#)

Configuring the boot drive

The drive or device from which the system boots is determined by the boot order specified in the System Setup.

Solid State Drive (SSD) backplane

The SSD backplane of your system allows you to use hot-swappable SSDs. You can remove and install the SSD backplane.

Removing the SSD backplane

Prerequisites

- ⚠ CAUTION:** Many repairs may only be done by a certified service technician. You should only perform troubleshooting and simple repairs as authorized in your product documentation, or as directed by the online or telephone service and support team. Damage due to servicing that is not authorized by Dell is not covered by your warranty. Read and follow the safety instructions that came with the product.
- ⚠ CAUTION:** To prevent damage to the SSDs and the SSD backplane, you must remove the SSD carriers from the sled before removing the SSD backplane.
- ⚠ CAUTION:** You must note the bay number of each SSD and temporarily label them before removal so that you can reinstall them into their original bays.

- 1 Follow the safety guidelines listed in the Safety instructions section.
- 2 Follow the procedure listed in the Before working inside your system section.
- 3 Remove the SSD carrier(s).
- 4 Keep the Phillips #2 screwdriver ready.

Steps

- 1 Loosen the two captive screws on the backplane touch points that secure the SSD backplane to the SSD cage.
- 2 Holding the backplane at the touch points, lift the SSD backplane till it disengages from the connector on the system board.
- 3 Lift the backplane away from the SSD cage.

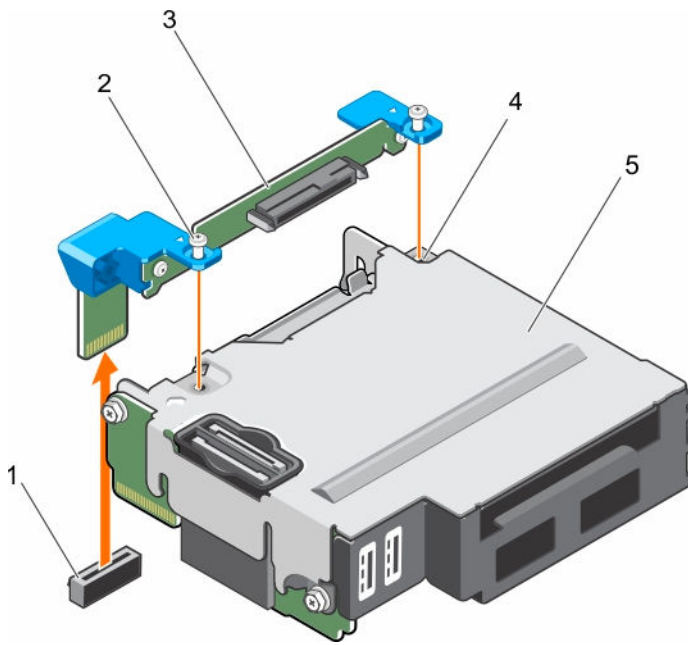

Figure 40. Removing the SSD backplane

- | | | | |
|---|---|---|--------------------------------|
| 1 | SSD backplane connector on system board | 2 | captive screw (2) |
| 3 | SSD backplane | 4 | screw hole on the SSD cage (2) |
| 5 | SSD cage | | |

Next steps

- 1 Install the SSD backplane.
- 2 Install the SSD carrier(s).
- 3 Follow the procedure listed in the After working inside your system section.

Related links

- [Safety instructions](#)
- [Before working inside your system](#)
- [Removing an SSD carrier](#)
- [Installing the SSD backplane](#)
- [Installing an SSD carrier](#)
- [After working inside your system](#)

Installing the SSD backplane

Prerequisites

⚠ CAUTION: Many repairs may only be done by a certified service technician. You should only perform troubleshooting and simple repairs as authorized in your product documentation, or as directed by the online or telephone service and support team. Damage due to servicing that is not authorized by Dell is not covered by your warranty. Read and follow the safety instructions that came with the product.

📌 NOTE: You must remove the SSD backplane to replace a faulty SSD backplane.

- 1 Follow the safety guidelines listed in the Safety instructions section.
- 2 Follow the procedure listed in the Before working inside your system section.

- 3 Remove the SSD backplane.
- 4 Keep the Phillips #2 screwdriver ready.

Steps

- 1 Align the screws on the SSD backplane with the screw holes on the SSD cage.
- 2 Press the SSD backplane into place until the retention screws on the SSD backplane engage with the screw holes on the SSD cage.
- 3 Ensure that the backplane connector is seated firmly in the socket on the system board and tighten the two captive screws to secure the backplane to the SSD cage.

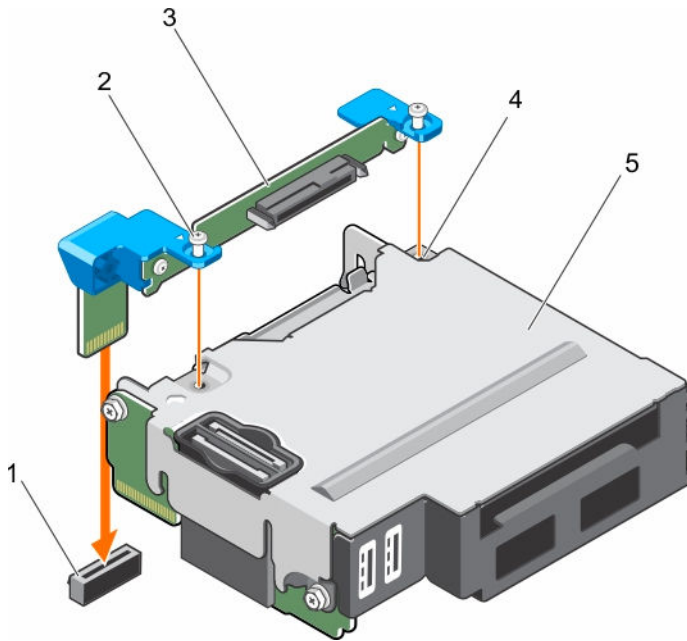

Figure 41. Installing the SSD backplane

- | | | | |
|---|---|---|--------------------------------|
| 1 | SSD backplane connector on system board | 2 | captive screw (2) |
| 3 | SSD backplane | 4 | screw hole on the SSD cage (2) |
| 5 | SSD cage | | |

Next steps

- 1 Install the SSD carriers into their original bays.
- 2 Follow the procedure listed in the After working inside your system section.

Related links

- [Safety instructions](#)
- [Before working inside your system](#)
- [Removing the SSD backplane](#)
- [Installing an SSD carrier](#)
- [After working inside your system](#)

System battery

The NVRAM backup battery installed in your system helps to retain the BIOS settings and configurations even if the power is switched off.

Replacing the NVRAM backup battery

Prerequisites

- ⚠ WARNING:** There is a danger of a new battery exploding if it is incorrectly installed. Replace the battery only with the same or equivalent type recommended by the manufacturer. Discard used batteries according to the manufacturer's instructions. See the safety instructions that came with your system for additional information.
- ⚠ CAUTION:** Many repairs may only be done by a certified service technician. You should only perform troubleshooting and simple repairs as authorized in your product documentation, or as directed by the online or telephone service and support team. Damage due to servicing that is not authorized by Dell is not covered by your warranty. Read and follow the safety instructions that are shipped with your product.

- 1 Follow the safety guidelines listed in the Safety instructions section.
- 2 Follow the procedure listed in the Before working inside your system section.
- 3 Remove the cooling shroud.

Steps

- 1 Locate the system battery.
- 2 Hold the battery and pull it toward the positive side of the battery till the battery disengages from the connector.
- 3 Lift the battery up and away from the system.

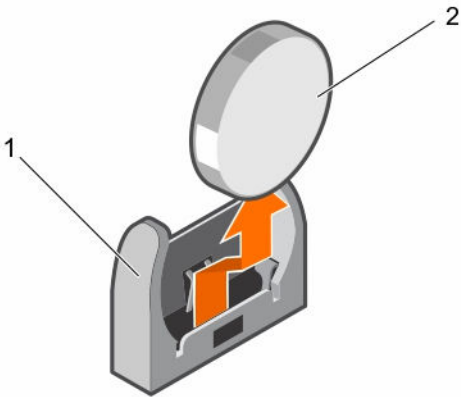

Figure 42. Removing the NVRAM backup battery

1 negative side of battery connector

2 positive side of battery

- 4 To install a new system battery, hold the battery with the "+" sign facing the positive side of the battery connector.
- 5 Place the battery straight down into the connector and push the positive side of the battery till the battery snaps into place.

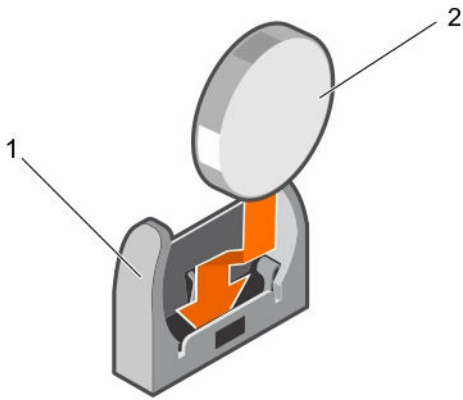

Figure 43. Installing the NVRAM backup battery

1 negative side of battery connector

2 positive side of battery

Next steps

- 1 Install the cooling shroud.
- 2 Follow the procedure listed in the After working inside your system section.
- 3 Enter System Setup to confirm that the battery is operating properly.
- 4 Enter the correct time and date in the System Setup's **Time** and **Date** fields.
- 5 Exit System Setup.
- 6 To test the freshly installed battery, leave the sled disconnected for at least an hour.
- 7 Reconnect the sled after an hour has passed.
- 8 Enter System Setup and if the time and date are still incorrect, see the Getting help section.

Related links

[Getting help](#)

[Safety instructions](#)

[Before working inside your system](#)

[Installing the cooling shroud](#)

[After working inside your system](#)

System board

A system board (also known as the motherboard) is the main printed circuit board found in computers. The system board allows communication between many of the crucial electronic components of the computer, such as the central processing unit (CPU) and memory, and also provides connectors for other peripherals. Unlike a backplane, a system board contains significant number subsystems such as the processor expansion cards, and other components.

Removing the system board

Prerequisites

⚠ CAUTION: Many repairs may only be done by a certified service technician. You should only perform troubleshooting and simple repairs as authorized in your product documentation, or as directed by the online or telephone service and support team. Damage due to servicing that is not authorized by Dell is not covered by your warranty. Read and follow the safety instructions that came with the product.

NOTE: This is a Field Replaceable Unit (FRU). Removal and installation procedures should be performed only by Dell certified service technicians.

CAUTION: If you are using Trusted Program Module (TPM) with an encryption key, you may be prompted to create a recovery key during program or System Setup. Be sure to create and safely store this recovery key. If you replace this system board, you must supply the recovery key when you restart your system or program before you can access the encrypted data on your hard drives.

CAUTION: Do not attempt to remove the TPM plug-in module from the motherboard. Once the TPM plug-in module is installed, it is cryptographically bound to that specific motherboard. Any attempt to remove an installed TPM plug-in module breaks the cryptographic binding, and it cannot be re-installed or installed on another motherboard.

- 1 Follow the safety guidelines listed in the Safety instructions section.
- 2 Follow the procedure listed in the Before working inside your system section.
- 3 Remove the following components:
 - Processor(s) and heat sink(s)
 - Memory modules
 - Cooling shroud
 - SSD carriers
 - SSD backplane
 - SSD cage
 - PCIe mezzanine card
 - LOM riser card
- 4 Keep the Phillips #2 screwdriver, along with the 4 mm and 5 mm Hex nut drivers ready.

CAUTION: Do not lift the system board by holding a memory module, processor, or other components.

CAUTION: You must temporarily label the SSD before removal so that you can replace them in their original bays.

WARNING: The processor and heat sink can become extremely hot. Be sure the processor has sufficient time to cool before handling.

WARNING: The memory modules are hot to touch for some time after the system has been powered down. Allow the memory modules to cool before handling them. Handle the memory modules by the card edges and avoid touching the components.

Steps

- 1 Remove the screws on the system board that secure the system board to the chassis.
- 2 By holding the system board handle, lift the system board away from the chassis.

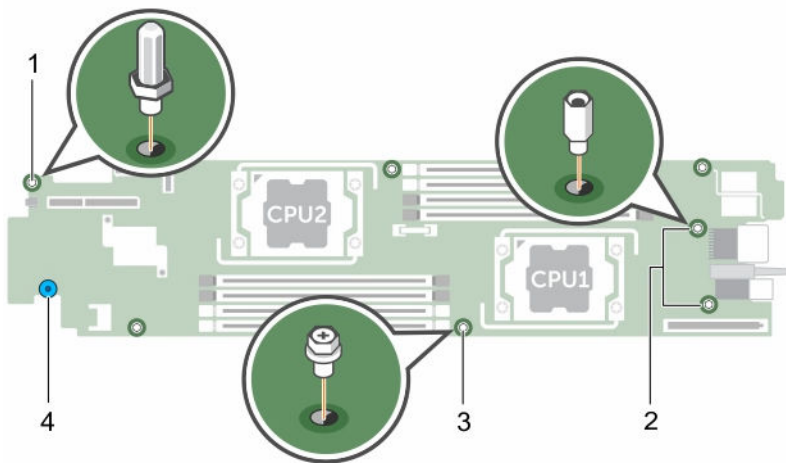

Figure 44. Screw location on the system board

1 Hex nut screw 4 mm

2 Hex nut screw 5 mm (2)

3 screw (4)

4 system board holder

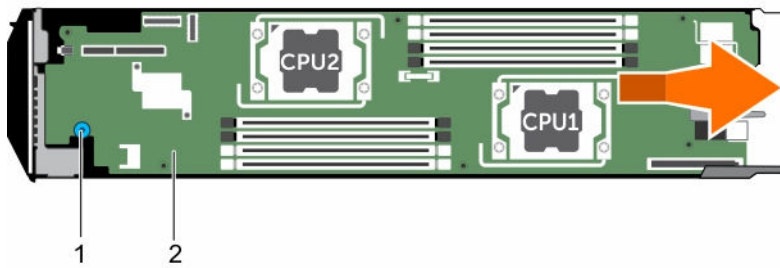

Figure 45. Removing the system board

1 system board holder

2 system board

Next steps

- 1 Install the system board.
- 2 Follow the procedure listed in the After working inside your system section.

Related links

- [Safety instructions](#)
- [Before working inside your system](#)
- [Removing a heat sink](#)
- [Removing a processor](#)
- [Removing memory modules](#)
- [Removing an SSD carrier](#)
- [Removing the SSD backplane](#)
- [Removing the SSD cage](#)
- [Removing the PCIe mezzanine card](#)
- [Removing the LOM riser card](#)
- [Installing the system board](#)
- [After working inside your system](#)

Installing the system board

Prerequisites

⚠ CAUTION: Many repairs may only be done by a certified service technician. You should only perform troubleshooting and simple repairs as authorized in your product documentation, or as directed by the online or telephone service and support team. Damage due to servicing that is not authorized by Dell is not covered by your warranty. Read and follow the safety instructions that came with the product.

📌 NOTE: This is a Field Replaceable Unit (FRU). Removal and installation procedures should be performed only by Dell certified service technicians.

📌 NOTE: You must remove the system board to replace a faulty system board.

- 1 Follow the safety guidelines listed in the Safety instructions section.
- 2 Follow the procedure listed in the Before working inside your system section.
- 3 Remove the system board.
- 4 Unpack the new system board assembly.
- 5 Keep the Phillips #2 screwdriver, the 4 mm and 5 mm Hex nut drivers ready.

⚠ **CAUTION:** Do not lift the system board by holding a memory module, processor, or other components.

⚠ **CAUTION:** Take care not to damage the system identification button while placing the system board into the chassis.

Steps

- 1 Align the system board with the standoffs on the chassis.
- 2 Secure the system board to the chassis with the screws.

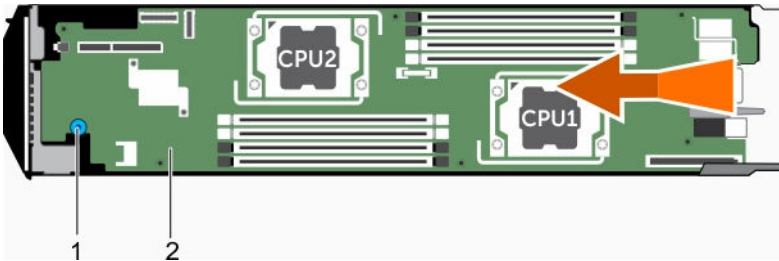

Figure 46. Installing the system board

1 system board holder

2 system board

Next steps

- 1 Install the Trusted Platform Module (TPM). For information about how to install TPM, see the Installing the trusted platform modules section. For information about TPM, see the Trusted Platform Module section.
- 2 Install the following components:

- LOM riser card
- PCIe mezzanine card
- SSD cage
- SSD backplane
- SSD carriers

NOTE: Ensure that you reinstall the SSD carriers into their original bays.

- Cooling shroud
- Memory modules
- Processor(s) and heat sink(s)

- 3 Follow the procedure listed in the After working inside your system section.

NOTE: If you are not installing the sled in the enclosure, install the I/O connector cover.

- 4 Import your new or existing iDRAC Enterprise license. See the *iDRAC8 User's Guide* at Dell.com/idracmanuals.
- 5 Ensure that you:
 - a Use the Easy Restore feature to restore the Service Tag. For more information, see the Restoring the Service Tag using Easy Restore section.
 - b If the Service Tag is not backed up in the backup flash device, enter the system Service Tag manually. For more information, see the Entering the system Service Tag section.
 - c Update the BIOS and iDRAC versions.
 - d Re-enable the Trusted Platform Module (TPM). For more information, see the Re-enabling the TPM for BitLocker users or Re-enabling the TPM for Intel TXT users section.

Related links

- [Safety instructions](#)
- [Before working inside your system](#)
- [Removing the system board](#)
- [Installing the LOM riser card](#)
- [Installing the PCIe mezzanine card](#)
- [Installing the SSD cage](#)
- [Installing the SSD backplane](#)
- [Installing an SSD carrier](#)
- [Installing the cooling shroud](#)
- [Installing a processor](#)
- [Installing a heat sink](#)
- [After working inside your system](#)
- [Restoring the Service Tag by using the Easy Restore feature](#)
- [Entering the system Service Tag by using System Setup](#)
- [Initializing the TPM for BitLocker users](#)
- [Initializing the TPM for TXT users](#)

Restoring the Service Tag by using the Easy Restore feature

By using the Easy Restore feature, you can restore your system's Service Tag, license, UEFI configuration, and the system configuration data after replacing the system board. All data is automatically backed up in an rSPI card automatically. If BIOS detects a new system board and the Service Tag in the rSPI card, BIOS prompts the user to restore the backup information.

- 1 Turn on the system.
If BIOS detects a new system board, and if the Service Tag is present in the rSPI card, BIOS displays the Service Tag, the status of the license, and the **UEFI Diagnostics** version.
- 2 Perform one of the following steps:
After the restore process is complete, BIOS prompts to restore the system configuration data.
- 3 Perform one of the following steps:
 - Press **Y** to restore the system configuration data.
 - Press **N** to use the default configuration settings.After the restore process is complete, the system restarts.

Entering the system Service Tag by using System Setup

If Easy Restore fails to restore the Service Tag, use System Setup to enter the Service Tag.

- 1 Turn on the system.
- 2 Press F2 to enter System Setup.
- 3 Click **Service Tag Settings**.
- 4 Enter the Service Tag.

NOTE: You can enter the Service Tag only when the Service Tag field is empty. Ensure that you enter the correct Service Tag. After the Service Tag is entered, it cannot be updated or changed.

- 5 Click **Ok**.
- 6 Import your new or existing iDRAC Enterprise license.
For more information, see the *Integrated Dell Remote Access Controller User's Guide* at Dell.com/idracmanuals.

Trusted Platform Module

Trusted Platform Module (TPM) is a dedicated microprocessor designed to secure hardware by integrating cryptographic keys into devices. A software can use a Trusted Platform Module to authenticate hardware devices. As each TPM chip has a unique and secret RSA key burned in as it is produced, it can perform the platform authentication.

⚠ CAUTION: Do not attempt to remove the Trusted Platform Module (TPM) from the system board. After the TPM is installed, it is cryptographically bound to that specific system board. Any attempt to remove an installed TPM breaks the cryptographic binding, and it cannot be re-installed or installed on another system board.

📌 NOTE: This is a Field Replaceable Unit (FRU). Removal and installation procedures must be performed only by Dell certified service technicians.

Installing the Trusted Platform Module

Prerequisites

⚠ CAUTION: Many repairs may only be done by a certified service technician. You should only perform troubleshooting and simple repairs as authorized in your product documentation, or as directed by the online or telephone service and support team. Damage due to servicing that is not authorized by Dell is not covered by your warranty. Read and follow the safety instructions that are shipped with your product.

- 1 Follow the safety guidelines listed in the Safety instructions section.
- 2 Follow the procedure listed in the Before working inside your system section.

Steps

- 1 Locate the TPM connector on the system board.

📌 NOTE: To locate the TPM connector on the system board, see the System board connectors section.

- 2 Align the edge connectors on the TPM with the slot on the TPM connector.
- 3 Insert the TPM into the TPM connector such that the plastic rivet aligns with the slot on the system board.
- 4 Press the plastic rivet until the rivet snaps into place.

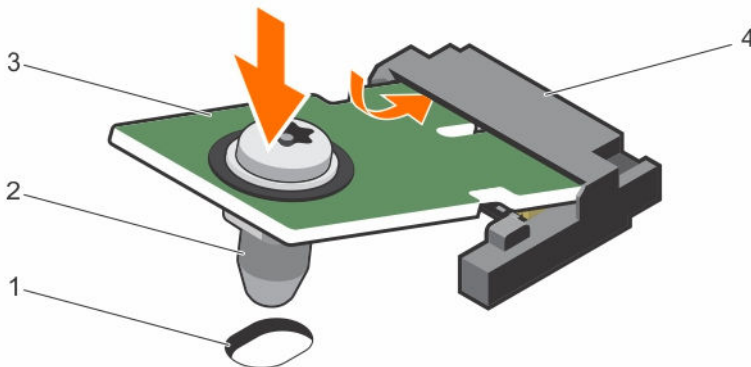

Figure 47. Installing the TPM

- | | | | |
|---|--------------------------------|---|---------------|
| 1 | rivet slot on the system board | 2 | plastic rivet |
| 3 | TPM | 4 | TPM connector |

Next steps

- 1 Install the system board.
- 2 Follow the procedure listed in the After working inside your system section.

Initializing the TPM for BitLocker users

Initialize the TPM.

For more information about initializing the TPM, see <http://technet.microsoft.com/en-us/library/cc753140.aspx>.

The **TPM Status** changes to **Enabled, Activated**.

Initializing the TPM for TXT users

- 1 While booting your system, press F2 to enter System Setup.
- 2 On the **System Setup Main Menu** screen, click **System BIOS** → **System Security Settings**.
- 3 From the **TPM Security** option, select **On with Pre-boot Measurements**.
- 4 From the **TPM Command** option, select **Activate**.
- 5 Save the settings.
- 6 Restart your system.
- 7 Enter **System Setup** again.
- 8 On the **System Setup Main Menu** screen, click **System BIOS** → **System Security Settings**.
- 9 From the **Intel TXT** option, select **On**.

Using system diagnostics

If you experience a problem with your system, run the system diagnostics before contacting Dell for technical assistance. The purpose of running system diagnostics is to test your system hardware without requiring additional equipment or risking data loss. If you are unable to fix the problem yourself, service and support personnel can use the diagnostics results to help you solve the problem.

Dell Embedded System Diagnostics

 **NOTE:** The Dell Embedded System Diagnostics is also known as Enhanced Pre-boot System Assessment (ePSA) diagnostics.

The Embedded System Diagnostics provides a set of options for particular device groups or devices allowing you to:

- Run tests automatically or in an interactive mode
- Repeat tests
- Display or save test results
- Run thorough tests to introduce additional test options to provide extra information about the failed device(s)
- View status messages that inform you if tests are completed successfully
- View error messages that inform you of problems encountered during testing

When to use the Embedded System Diagnostics

Run the Embedded System Diagnostics (ePSA) if your system does not boot.

Running the Embedded System Diagnostics

Run the Embedded System Diagnostics (ePSA) if your system does not boot. The embedded system diagnostics program is run from the Dell Lifecycle Controller.

Prerequisites

If a major component or device in the system does not operate properly, running the embedded system diagnostics may indicate component failure.

 **CAUTION:** Use the embedded system diagnostics to test only your system. Using this program with other systems may cause invalid results or error messages.

Steps

- 1 As the system boots, press F11.
- 2 Use the up and down arrow keys to select **System Utilities > Launch Dell Diagnostics**.
The **ePSA Pre-boot System Assessment** window is displayed, listing all devices detected in the system. The diagnostics starts running the tests on all the detected devices.

System diagnostics controls

Menu	Description
Configuration	Displays the configuration and status information of all detected devices.
Results	Displays the results of all tests that are run.
System Health	Provides the current overview of the system performance.
Event Log	Displays a time-stamped log of the results of all tests run on the system. This is displayed if at least one event description is recorded.

For information about embedded system diagnostics, see the *Dell Enhanced Pre-boot System Assessment User Guide* at [Dell.com/support/home](https://www.dell.com/support/home).

Jumpers and connectors

This topic provides specific information about the system jumpers. It also provides some basic information about jumpers and switches and describes the connectors on the various boards in the system. Jumpers on the system board help to disable system and setup passwords. You must know the connectors on the system board to install components and cables correctly.

Topics:





- [System board jumper settings](#)
- [System board connectors](#)
- [Disabling a forgotten password](#)

System board jumper settings

CAUTION: Many repairs may only be done by a certified service technician. You should only perform troubleshooting and simple repairs as authorized in your product documentation, or as directed by the online or telephone service and support team. Damage due to servicing that is not authorized by Dell is not covered by your warranty. Read and follow the safety instructions that are shipped with your product.

For information on resetting the password jumper to disable a password, see the Disabling a forgotten password section.

Table 30. System board jumper settings

Jumper	Setting	Description
NVRAM_CLR	 (default)	The configuration settings are retained at system boot.
		The configuration settings are cleared at the next system boot.
PWRD_EN	 (default)	The password feature is enabled.
		The password feature is disabled.

Related links

[Disabling a forgotten password](#)

System board connectors

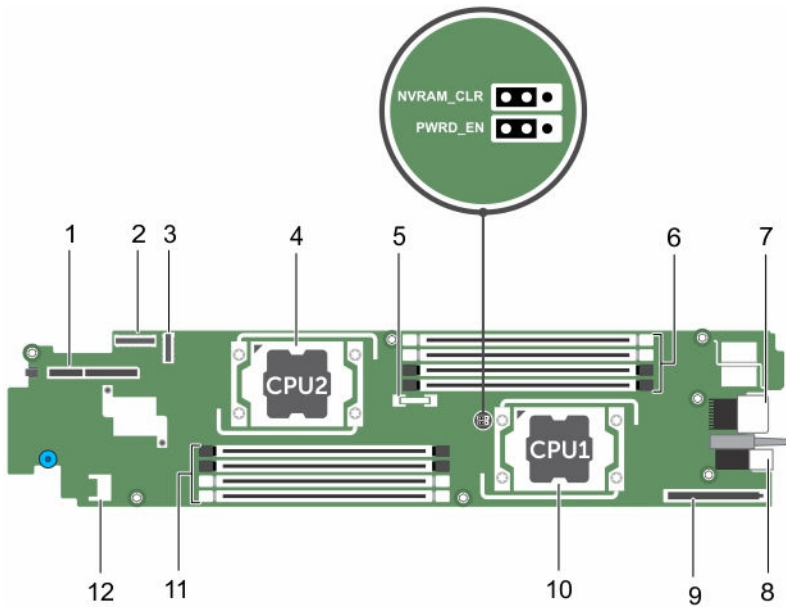

Figure 48. System board connectors

Table 31. System board connectors

Item	Connector	Description
1	DCS IB MEZZ	PCIe mezzanine card connector
2	J_IDSDM	IDSDM/vFlash and USB connector
3	J_SSDBP	SSD backplane connector
4	CPU2	Processor socket 2
5	BAT1	System battery
6	A4, A3, A2, A1	Memory module sockets (processor 1)
7	J_MIDPLANE1	Sled connector to the interposer card
8	PWR_CONN	Power connector
9	LOM RISER	LOM riser card connector
10	CPU1	Processor socket 1
11	B4, B3, B2, B1	Memory module sockets (processor 2)
12	TPM	TPM connector

Disabling a forgotten password

The software security features of sled include a system password and a setup password. The password jumper enables these password features or disables them, and clears any password(s) currently in use.

Prerequisites

⚠ CAUTION: Many repairs may only be done by a certified service technician. You should only perform troubleshooting and simple repairs as authorized in your product documentation, or as directed by the online or telephone service and support team. Damage due to servicing that is not authorized by Dell is not covered by your warranty. Read and follow the safety instructions that came with the product.

Steps

- 1 Turn off the sled using the operating system commands or the CMC.
- 2 Remove the sled from the enclosure.
- 3 Relocate the jumper plug to disable the password feature.
- 4 Install the sled in the enclosure.
- 5 Turn on the sled.

When the sled is on, the power-on indicator is solid green. Allow the sled to finish booting.

The existing passwords are not disabled (erased) until the system boots with the password jumper removed. However, before you assign a new system and/or setup password, you must reinstall the password jumper.

ⓘ NOTE: If you assign a new system and/or setup password with the jumper removed, the system disables the new password(s) the next time it boots.

- 6 Turn off the sled.
- 7 Remove the sled from the enclosure.
- 8 Remove the system board to gain access to the jumpers.
- 9 Relocate the jumper plug to enable the password feature.
- 10 Reinstall the system board.
- 11 Install the sled in the enclosure.
- 12 Turn on the sled.
- 13 Assign a new system and/or setup password.

Troubleshooting your system

Safety first — for you and your system

CAUTION: Many repairs may only be done by a certified service technician. You should only perform troubleshooting and simple repairs as authorized in your product documentation, or as directed by the online or telephone service and support team. Damage due to servicing that is not authorized by Dell is not covered by your warranty. Read and follow the safety instructions that are shipped with your product.

NOTE: Solution validation was performed by using the factory shipped hardware configuration.

Topics:

- [Troubleshooting system memory](#)
- [Troubleshooting Solid State Drives](#)
- [Troubleshooting USB devices](#)
- [Troubleshooting an internal SD card](#)
- [Troubleshooting processors](#)
- [Troubleshooting the system board](#)
- [Troubleshooting the NVRAM backup battery](#)

Troubleshooting system memory

Prerequisites

CAUTION: Many repairs may only be done by a certified service technician. You should only perform troubleshooting and simple repairs as authorized in your product documentation, or as directed by the online or telephone service and support team. Damage due to servicing that is not authorized by Dell is not covered by your warranty. Read and follow the safety instructions that are shipped with your product.

NOTE: Before performing the following procedure, ensure that you have installed the memory modules according to the memory installation guidelines for the sled.

Steps

- 1 Restart the sled:
 - a Press the power button once to turn off the sled.
 - b Press the power button again to turn on the sled.If no error messages appear, go to step 7.
- 2 Enter System Setup and check the system memory setting.
If the amount of memory installed matches the system memory setting, go to step 7.
- 3 Turn off the sled using the operating system commands or the CMC.
- 4 Remove the sled from the enclosure.

CAUTION: The memory modules are hot to touch for some time after the sled has been powered down. Allow time for the memory modules to cool before handling them. Handle the memory modules by the card edges and avoid touching the components.

- 5 Reseat the memory modules in their sockets.

- 6 Install the sled in the enclosure.
- 7 Turn on the sled.
- 8 Run the appropriate diagnostic test. For more information, see the Using system diagnostics section.
If the test fails, see the Getting help section.

Related links

- [Using system diagnostics](#)
- [Getting help](#)

Troubleshooting Solid State Drives

Prerequisites

- CAUTION:** Many repairs may only be done by a certified service technician. You should only perform troubleshooting and simple repairs as authorized in your product documentation, or as directed by the online or telephone service and support team. Damage due to servicing that is not authorized by Dell is not covered by your warranty. Read and follow the safety instructions that are shipped with your product.
- CAUTION:** This troubleshooting procedure can destroy data stored on the SSD. Before you proceed, back up all the files on the SSD, if possible.

Steps

- 1 Run the appropriate tests in system diagnostics.
If the tests fail, go to step 3.
 - 2 Take the SSD offline and wait until the indicator codes on the SSD carrier signal that the SSD may be removed safely, then remove and reseat the SSD carrier in the sled.
 - 3 Restart the sled, enter the System Setup and confirm that the drive controller is enabled.
 - 4 Ensure that any required device drivers are installed and are configured correctly.
- NOTE:** Installing a SSD into another bay may break the mirror if the mirror state is optimal.
- 5 Remove the SSD and install it in the other SSD slot.
 - 6 If the problem is resolved, reinstall the SSD in the original slot.
If the SSD functions properly in the original slot, the SSD carrier could have intermittent problems. Replace the SSD carrier.
 - 7 If the SSD is the boot drive, ensure that the SSD is configured and connected properly.
 - 8 Partition and logically format the SSD.
 - 9 If possible, restore the files to the SSD.
If the problem persists, see the Getting help section.

Related links

- [Getting help](#)

Troubleshooting USB devices

Prerequisites

- CAUTION:** Many repairs may only be done by a certified service technician. You should only perform troubleshooting and simple repairs as authorized in your product documentation, or as directed by the online or telephone service and support team. Damage due to servicing that is not authorized by Dell is not covered by your warranty. Read and follow the safety instructions that are shipped with your product.

Steps

- 1 Ensure that the sled is turned on.
- 2 Check the USB device connection to the sled.
- 3 Swap the USB device with a working USB device.
- 4 Connect the USB devices to the sled by using a powered USB hub.

- 5 If another sled is installed, connect the USB device to that sled. If the USB device works with a different sled, the first sled's USB ports may be faulty. See the Getting help section.

Related links

[Getting help](#)

Troubleshooting an internal SD card

Prerequisites

⚠ CAUTION: Many repairs may only be done by a certified service technician. You should only perform troubleshooting and simple repairs as authorized in your product documentation, or as directed by the online or telephone service and support team. Damage due to servicing that is not authorized by Dell is not covered by your warranty. Read and follow the safety instructions that are shipped with your product.

ℹ NOTE: SD card slot 2 referred in this procedure is the vFlash SD card slot. You can install an SD card in SD card slot 2 to enable the Internal SD Card Redundancy option in the Integrated Devices screen of the System Setup.

Steps

- 1 Enter System Setup and ensure that the **Internal SD Card Port** is enabled.
- 2 Note the **Internal SD Card Redundancy** option enabled in the **Integrated Devices** screen of the System Setup (Mirror or Disabled).
ℹ NOTE: If you retain the original settings of the SD card in the System Setup, the replaced SD card is enabled when you reinstall the sled in the enclosure.
- 3 Remove the sled from the enclosure.
- 4 If the **Internal SD Card Redundancy** option in the **Integrated Devices** screen of the System Setup is set to Mirror mode and SD card 1 has failed:
 - a Remove the SD card from SD card slot 1.
 - b Remove the SD card present in SD card slot 2 and insert it into SD card slot 1.
 - c Install a new SD card in slot 2.
- 5 If the **Internal SD Card Redundancy** option in the **Integrated Devices** screen of the System Setup is set to Mirror mode and SD card 2 has failed, insert the new SD card into SD card slot 2.
- 6 If the **Internal SD Card Redundancy** option in **Integrated Devices** screen of the System Setup is set to Disabled, replace the failed SD card with a new SD card.
- 7 Install the sled in the enclosure.
- 8 Enter System Setup and ensure that the **Internal SD Card Port** option is enabled and **Internal SD Card Redundancy** option is set to Mirror mode.
- 9 Check if the SD card is functioning properly.
If the problem persists, see the Getting help section.

Related links

[Getting help](#)

Troubleshooting processors

- 1 Turn off the sled using the operating system commands or the CMC.
- 2 Remove the sled from the enclosure.
- 3 Ensure that the processor(s) and heat sink(s) are properly installed.
- 4 If your system has only one processor installed, ensure that it is installed in the primary processor socket (CPU1).
- 5 Install the sled in the enclosure.
- 6 Turn on the sled.
- 7 Run the appropriate diagnostic test. For more information, see the Using system diagnostics section.
If the problem persists, see the Getting help section.

Related links

- [Using system diagnostics](#)
- [Getting help](#)

Troubleshooting the system board

Prerequisites

⚠ CAUTION: Many repairs may only be done by a certified service technician. You should only perform troubleshooting and simple repairs as authorized in your product documentation, or as directed by the online or telephone service and support team. Damage due to servicing that is not authorized by Dell is not covered by your warranty. Read and follow the safety instructions that are shipped with your product.

Steps

- 1 Turn off the sled using the operating system commands or the CMC.
- 2 Remove the sled from the enclosure.
- 3 Clear the sled NVRAM.
- 4 If the problem persists, remove and reinstall the sled in the enclosure.
- 5 Turn on the sled.
- 6 Run the appropriate diagnostic test. For more information, see the Using System Diagnostics section. If the tests fail, see the Getting help section.

Related links

- [Using system diagnostics](#)
- [Getting help](#)

Troubleshooting the NVRAM backup battery

Prerequisites

⚠ CAUTION: Many repairs may only be done by a certified service technician. You should only perform troubleshooting and simple repairs as authorized in your product documentation, or as directed by the online or telephone service and support team. Damage due to servicing that is not authorized by Dell is not covered by your warranty. Read and follow the safety instructions that are shipped with your product.

The battery maintains the sled configuration, date, and time information in the NVRAM when the sled is turned off. You may need to replace the battery if an incorrect time or date is displayed during the boot routine.

You can operate the sled without a battery; however, the sled configuration information maintained by the battery in NVRAM is erased each time you remove power supply unit from the sled. Therefore, you must reenter the system configuration information and reset the options each time the sled boots until you replace the battery.

Steps

- 1 Reenter the time and date through the System Setup.
 - 2 Turn off the sled using the operating system commands or the CMC.
 - 3 Remove the sled from the enclosure for at least one hour.
 - 4 Install the sled in the enclosure.
 - 5 Turn on the sled.
 - 6 Enter the System Setup.
- If the date and time are not correct in the System Setup, replace the battery. If the problem is not resolved by replacing the battery, see the Getting help section.

i NOTE: If the sled is turned off for long periods of time (for weeks or months), the NVRAM may lose its system configuration information. This situation is caused by a defective battery.

 **NOTE:** Some software may cause the sled's time to speed up or slow down. If the sled operates normally except for the time maintained by the System Setup, the problem may be caused by a software rather than by a defective battery.

Related links

[Getting help](#)

Getting help

Topics:

- [Contacting Dell](#)
- [Quick Resource Locator](#)

Contacting Dell

Dell provides several online and telephone-based support and service options. If you do not have an active internet connection, you can find contact information about your purchase invoice, packing slip, bill, or Dell product catalog. Availability varies by country and product, and some services may not be available in your area. To contact Dell for sales, technical assistance, or customer-service issues:

- 1 Go to **Dell.com/support**.
- 2 Select your country from the drop-down menu on the lower right corner of the page.
- 3 For customized support:
 - a Enter your system Service Tag in the **Enter your Service Tag** field.
 - b Click **Submit**.The support page that lists the various support categories is displayed.
- 4 For general support:
 - a Select your product category.
 - b Select your product segment.
 - c Select your product.The support page that lists the various support categories is displayed.
- 5 For contact details of Dell Global Technical Support:
 - a Click [Global Technical Support](#).
 - b The **Contact Technical Support** page is displayed with details to call, chat, or e-mail the Dell Global Technical Support team.

Quick Resource Locator

Use the Quick Resource Locator (QRL) to get immediate access to system information and how-to videos. This can be done by visiting [dell.com/QRL](#) or by using your smartphone or tablet and a model specific Quick Resource (QR) code located on your Dell PowerEdge system. To try out the QR code, scan the following image.



Quick Resource Locator



www.dell.com/QRL/Server/PEFC430