

Dell Precision™ T5400 User's Guide

Model DCTA

Notes, Notices, and Cautions



NOTE: A NOTE indicates important information that helps you make better use of your computer.



NOTICE: A NOTICE indicates either potential damage to hardware or loss of data and tells you how to avoid the problem.



CAUTION: A CAUTION indicates a potential for property damage, personal injury, or death.

Information in this document is subject to change without notice.

© 2007 Dell Inc. All rights reserved.

Reproduction in any manner whatsoever without the written permission of Dell Inc. is strictly forbidden.

Trademarks used in this text: *Dell*, the *DELL* logo, *Dell Precision*, and *Dell OpenManage* are trademarks of Dell Inc.; *Intel*, *Speedstep*, and *Xeon* are registered trademarks of Intel Corporation; *Microsoft*, *Windows*, and *Windows Vista* are either trademarks or registered trademarks of Microsoft Corporation in the United States and/or other countries.

Other trademarks and trade names may be used in this document to refer to either the entities claiming the marks and names or their products. Dell Inc. disclaims any proprietary interest in trademarks and trade names other than its own.

Model DCTA

August 2007

P/N NX046 Rev. A00

Contents

1	Finding Information	11
2	About Your Computer	19
	Front View of the Computer (Tower Orientation)	19
	Back View of the Computer (Tower Orientation)	21
	Back Panel Connectors (Tower Orientation)	22
	Front View (Desktop Orientation)	24
	Back View (Desktop Orientation)	25
	Inside View	26
	Inside View – Hard Drive Bay Rotated Out	27
	System Board Components	28
	Cable Colors	29
	Changing Between Tower and Desktop Modes	30
	Specifications	36
3	Advanced Features	45
	LegacySelect Technology Control	45
	Manageability	45
	Alert Standard Format	45
	Dell OpenManage™ IT Assistant	47

	Dell OpenManage Client Instrumentation	47
	Power Management	47
	About RAID Configurations	49
	RAID Level 0	50
	RAID Level 1	51
	RAID Level 5	51
	Configuring Your Computer for RAID	53
	Configuring Your Computer for RAID Using the Intel Matrix Storage Manager	53
	Configuring Your Computer for RAID Using the Intel® RAID Option ROM Utility	61
4	Setting Up Your Computer	65
	Installing Your Computer in an Enclosure	65
	Connecting to the Internet	67
	Setting Up Your Internet Connection	68
	Transferring Information to a New Computer	69
	Microsoft® Windows® XP	70
	Microsoft Windows Vista™	73
	Power Protection Devices	73
	Surge Protectors	74
	Line Conditioners	74
	Uninterruptible Power Supplies	74
5	Securing Your Computer	75
	Chassis Intrusion Detection	75
	Removing the Chassis Intrusion Switch	75
	Replacing the Chassis Intrusion Switch	76

Resetting the Chassis Intrusion Detector	76
Security Cable Lock	77
Passwords	78
About Passwords	78
Using a Primary (or System) Password	79
Using an Administrator Password	82
Disabling a Forgotten Password and Setting a New Password	84
Trusted Platform Module (TPM)	85
Enabling the TPM Feature	85
Security Management Software	86
Activating the Security Management Software	86
Using the Security Management Software	86
Computer Tracking Software	86
If Your Computer Is Lost or Stolen	87
6 System Setup	89
Overview	89
Entering System Setup	89
System Setup Options	89
Boot Menu	97
Option Settings	98
Selecting the Boot Device for the Current Boot	98
Changing Boot Sequence for Future Boots	99
Booting to a USB Device	99

7	Clearing Forgotten Passwords	101
	Clearing CMOS Settings	103
	Flashing the BIOS	103
8	Cleaning Your Computer	105
	Computer, Keyboard, and Monitor	105
	Floppy Drive	105
	CDs and DVDs	105
9	Troubleshooting	107
	Solving Problems	107
	Battery Problems	107
	Drive Problems	107
	E-Mail and Internet Problems	109
	Error Messages	110
	IEEE 1394 Device Problems	111
	Keyboard Problems	112
	Lockups and Software Problems	112
	Memory Problems	114
	Mouse Problems	115
	Network Problems	116
	Power Problems	116
	Printer Problems	117
	Scanner Problems	118
	Sound Problems	119
10	Troubleshooting Tools	121
	Diagnostic Lights	121

Diagnostic Light Codes Before POST	121
Diagnostic Light Codes During POST	123
Beep Codes	129
Error Messages	130
Dell Diagnostics	136
When to Use the Dell Diagnostics	136
Starting the Dell Diagnostics From Your Hard Drive	137
Starting the Dell Diagnostics From the Drivers and Utilities Disc	137
Dell Diagnostics Main Menu	138
11 Reinstalling Software	141
Drivers	141
What Is a Driver?	141
Identifying Drivers	141
Reinstalling Drivers and Utilities	142
Troubleshooting Software and Hardware Problems in the Microsoft® Windows® XP and Microsoft Windows Vista™ Operating Systems	143
Restoring Your Operating System	144
Using Microsoft Windows System Restore	144
Using Dell™ PC Restore and Dell Factory Image Restore	146
Using the Operating System Disc	149
12 Adding and Replacing Parts	151
Before You Begin	151

Recommended Tools	151
Turning Off Your Computer	151
Before Working Inside Your Computer	152
Removing the Computer Cover and Front Panel	153
Removing the Computer Cover	153
Removing the Front Panel	155
Rotating the Hard Drive Carrier Out of the Computer	156
Replacing the Front Panel and Computer Cover	158
Rotating the Hard-Drive Carrier Back into the Computer	159
Replacing the Front Panel	160
Replacing the Computer Cover	161
I/O Panel	163
I/O-Panel Components	164
Removing the I/O Panel	165
Replacing the I/O Panel	167
Power Supply	167
Power Supply DC Connector Pin Assignments	167
Removing the Power Supply	174
Replacing the Power Supply	176
Battery	176
About the Battery	176
Replacing the Battery	177
Processor	179
Removing the Processor	179
Installing the Processor	183
Memory	187
Fully Buffered DIMM (FBD) Memory Overview	187

Addressing Memory With 4-GB or Greater Configurations (32-bit Operating Systems Only) . . .	188
Removing Memory	189
Installing Memory	190
Cards	193
Expansion Card Support	193
Installing an Expansion Card	194
Removing an Expansion Card	201
Drives	205
Tower Computer Drives	205
Desktop Computer Drives	206
Controller Card Data Cable Connectors	212
Hard Drive	212
Drive Panels	233
Floppy Drive	239
Media Card Reader	254
Optical Drive	268
System Board	281
Removing the System Board	281
Replacing the System Board	284
13 Getting Help	289
Obtaining Assistance	289
Technical Support and Customer Service	290
Online Services	290
AutoTech Service	291
Automated Order-Status Service	291
Problems With Your Order	291
Product Information	291

Returning Items for Warranty Repair or Credit	292
Before You Call	292
Contacting Dell	295
A Appendix	297
FCC Notice (U.S. Only)	297
FCC Class B	297
Glossary	299

Finding Information

 **NOTE:** Some features or media may be optional and may not ship with your computer. Some features or media may not be available in certain countries.

 **NOTE:** Additional information may ship with your computer.

What Are You Looking For?

- A diagnostic program for my computer
- Drivers for my computer
- Desktop System Software (DSS)

Find It Here

Drivers and Utilities Disc

Documentation and drivers are already installed on your computer. You can use the *Drivers and Utilities* disc to reinstall drivers (see "Reinstalling Drivers and Utilities" on page 142), or to run the Dell Diagnostics (see "Dell Diagnostics" on page 136).

Readme files may be included on your *Drivers and Utilities* disc to provide last-minute updates about technical changes to your computer or advanced technical-reference material for technicians or experienced users.



NOTE: Drivers and documentation updates can be found at support.dell.com.

What Are You Looking For?

- How to set up my computer
- How to care for my computer
- Basic troubleshooting information
- How to run the Dell Diagnostics
- How to set up a printer
- How to open my computer

Find It Here

Quick Reference Guide

NOTE: This document may be optional and may not ship with your computer.



NOTE: This document is available as a PDF at support.dell.com.

Dell™ Product Information Guide

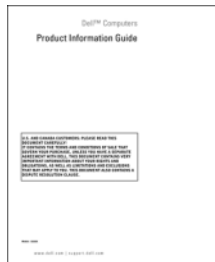

- Warranty information
- Terms and Conditions (U.S. only)
- Safety instructions
- Regulatory information
- Ergonomics information
- End User License Agreement

What Are You Looking For?

- Solutions — Troubleshooting hints and tips, articles from technicians, and online courses, frequently asked questions
- Community — Online discussion with other Dell customers
- Upgrades — Upgrade information for components, such as memory, the hard drive, and the operating system
- Customer Care — Contact information, service call and order status, warranty, and repair information
- Service and support — Service call status and support history, service contract, online discussions with technical support
- Dell Technical Update Service — Proactive e-mail notification of software and hardware updates for your computer
- Reference — Computer documentation, details on my computer configuration, product specifications, and white papers
- Downloads — Certified drivers, patches, and software updates
- Desktop System Software (DSS)— If you reinstall the operating system for your computer, you should also reinstall the DSS utility. DSS provides critical updates for your operating system and support for processors, optical drives, USB devices, and so on. DSS is necessary for correct operation of your Dell computer. The software automatically detects your computer and operating system and installs the updates appropriate for your configuration.

Find It Here

Dell Support Website — support.dell.com

NOTE: Select your region or business segment to view the appropriate support site.

To download Desktop System Software:

- 1** Go to support.dell.com, select your region or business segment, and enter your Service Tag.
- 2** Select **Drivers & Downloads** and click **Go**.
- 3** Click your operating system and search for the keyword *Notebook System Software*.

NOTE: The support.dell.com user interface may vary depending on your selections.

What Are You Looking For?

- How to use Microsoft Windows Vista™
- How to work with programs and files
- How to personalize my desktop

- How to reinstall my operating system

Find It Here

Windows Help and Support

- 1 Click the Windows Vista Start button , and then click **Help and Support**.
- 2 In *Search Help*, type a word or phrase that describes your problem, and then press <Enter> or click the magnifying glass.
- 3 Click the topic that describes your problem.
- 4 Follow the instructions on the screen.

Operating System Disc

NOTE: The *Operating System* disc may be optional and may not ship with your computer.

The operating system is already installed on your computer. To reinstall your operating system, use the *Operating System* disc (see "Reinstalling Windows XP or Windows Vista" on page 149).



After you reinstall your operating system, use the *Drivers and Utilities* disc to reinstall drivers for the devices that came with your computer.

Your operating system product key label is located on your computer.

NOTE: The color of your disc varies based on the operating system you ordered.

What Are You Looking For?

- How to use Linux
- E-mail discussions with users of Dell Precision™ products and the Linux operating system
- Additional information regarding Linux and my Dell Precision computer

Find It Here**Dell Supported Linux Sites**

- Linux.dell.com
- Lists.us.dell.com/mailman/listinfo/linux-precision

About Your Computer

Front View of the Computer (Tower Orientation)

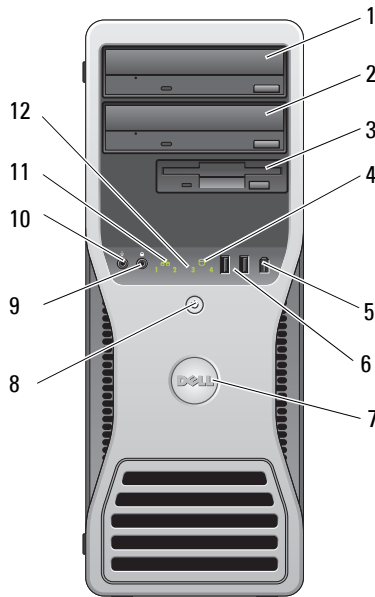

- | | | |
|---|---------------------------|---|
| 1 | upper 5.25-inch drive bay | Use this bay for an optical drive. |
| 2 | lower 5.25-inch drive bay | Use this bay for an optional optical drive. |
| 3 | FlexBay | Use this bay for an optional third hard drive (SATA or SAS), a floppy drive, or a Media Card Reader. |
| 4 | hard-drive activity light | The hard drive light is on when the computer reads data from or writes data to the hard drive. The light might also be on when a device, such as your CD drive, is operating. |

- | | | |
|----|--------------------------------|---|
| 5 | IEEE 1394 connector (optional) | Use the optional IEEE 1394 connector for high-speed data devices such as digital video cameras and external storage devices. |
| 6 | USB 2.0 connectors (2) | Use the front USB connectors for devices that you connect occasionally, such as flash memory keys or cameras, or for bootable USB devices (see "System Setup" on page 89 for more information on booting to a USB device).
It is recommended that you use the back USB connectors for devices that typically remain connected, such as printers and keyboards. |
| 7 | Dell™ rotatable badge | To rotate the Dell badge for tower-to-desktop conversion: remove the front panel (see "Removing the Computer Cover" on page 153), turn it over, and rotate the plastic handle behind the badge. |
| 8 | power button, power light | Press the power button to turn on the computer. The light in the center of this button indicates power state. See "Controls and Lights" on page 40 for more information.

 NOTICE: To avoid losing data, do not use the power button to turn off the computer. Instead, perform an operating system shutdown. |
| 9 | headphone connector | Use the headphone connector to attach headphones. |
| 10 | microphone connector | Use the microphone connector to attach a personal computer microphone for voice or musical input into a sound or telephony program. |
| 11 | network link light | The network link light is on when a good connection exists between a 10-Mbps, 100-Mbps, or 1000-Mbps (or 1-Gbps) network and the computer. |
| 12 | diagnostic lights (4) | Use these lights to help you troubleshoot a computer problem based on the diagnostic code. For more information, see "Diagnostic Lights" on page 121. |

Back View of the Computer (Tower Orientation)

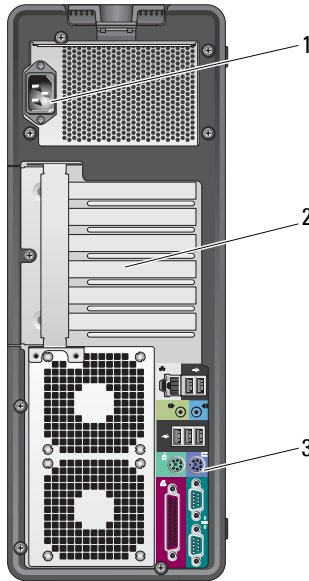

- | | | |
|---|-----------------------|--|
| 1 | power connector | Insert the power cable. |
| 2 | card slots | Access connectors for any installed PCI and PCI Express cards.
The center four connector slots support full-length cards, and the connector slots on either the top or bottom (one x8 PCI Express slot (wired as x4) and one PCI-X card) support half-length cards. |
| 3 | back panel connectors | Plug USB, audio, and other devices into the appropriate connector (see "Back Panel Connectors (Tower Orientation)" on page 22 for more information). |



CAUTION: Ensure that none of the system air vents are blocked. Blocking them will cause serious thermal problems.

Back Panel Connectors (Tower Orientation)

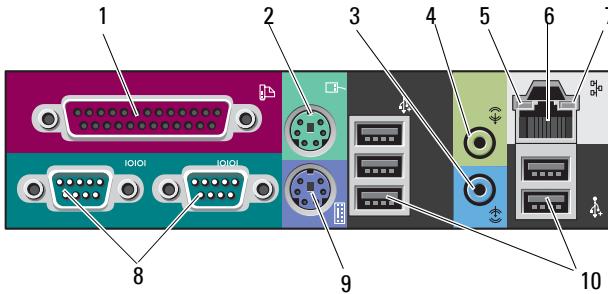

- 1 parallel connector Connect a parallel device, such as a printer, to the parallel connector. If you have a USB printer, plug it into a USB connector.

The integrated parallel connector is automatically disabled if the computer detects an installed card containing a parallel connector configured to the same address. For more information, see "System Setup Options" on page 89.
- 2 PS/2 mouse connector Plug a standard PS/2 mouse into the green mouse connector. Turn off the computer and any attached devices before you connect a mouse to the computer. If you have a USB mouse, plug it into a USB connector.
- 3 line-in connector Use the blue line-in connector to attach a playback device such as an MP3 player, CD player, or VCR.

On computers with a sound card, use the connector on the card.
- 4 line-out connector Use the green line-out connector to attach most speakers with integrated amplifiers.

On computers with a sound card, use the connector on the card.
- 5 link integrity light

Green — A good connection exists between a 10-Mbps network and the computer.

Orange — A good connection exists between a 100-Mbps network and the computer.

Yellow — A good connection exists between a 1000-Mbps (or 1-Gbps) network and the computer.

Off — The computer is not detecting a physical connection to the network.

- | | | |
|----|---------------------------|--|
| 6 | network adapter connector | <p>To attach your computer to a network or broadband device, connect one end of a network cable to either a network jack or your network or broadband device. Connect the other end of the network cable to the network adapter connector on your computer. A click indicates that the network cable has been securely attached.</p> <p>Do not plug a telephone cable into the network connector. On computers with an additional network connector card, use the connectors on the card and on the back of the computer when setting up multiple network connections (such as a separate intra- and extranet).</p> <p>It is recommended that you use Category 5 wiring and connectors for your network. If you must use Category 3 wiring, force the network speed to 10 Mbps to ensure reliable operation.</p> |
| 7 | network activity light | <p>Flashes a yellow light when the computer is transmitting or receiving network data. A high volume of network traffic may make this light appear to be in a steady "on" state.</p> |
| 8 | serial connectors (2) | <p>Connect a serial device, such as a handheld device, to the serial port. If necessary, the address for this port can be modified through "System Setup" on page 89.</p> |
| 9 | PS/2 keyboard connector | <p>If you have a standard PS/2 keyboard, plug it into the purple keyboard connector. If you have a USB keyboard, plug it into a USB connector.</p> |
| 10 | USB 2.0 connectors (5) | <p>It is recommended that you use the front USB connectors for devices that you connect occasionally, such as flash memory keys or cameras, or for bootable USB devices.</p> <p>Use the back USB connectors for devices that typically remain connected, such as printers and keyboards.</p> |

Front View (Desktop Orientation)

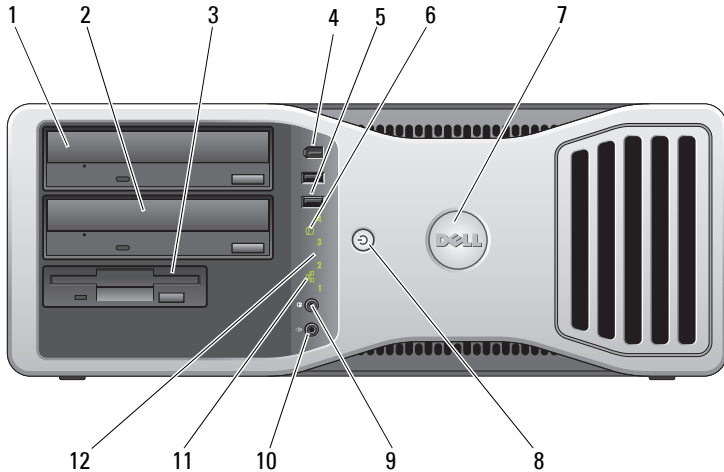

- | | | |
|---|--------------------------------|---|
| 1 | upper 5.25-inch drive bay | Use this bay for an optical drive. |
| 2 | lower 5.25-inch drive bay | Use this bay for an optional optical drive or a SATA hard drive. |
| 3 | FlexBay | Use this bay for a floppy drive or a Media Card Reader. |
| 4 | IEEE 1394 connector (optional) | Use the optional IEEE 1394 connector for high-speed data devices such as digital video cameras and external storage devices. |
| 5 | USB 2.0 connectors (2) | Use the front USB connectors for devices that you connect occasionally, such as flash memory keys or cameras, or for bootable USB devices (see "System Setup" on page 89 for more information on booting to a USB device).
It is recommended that you use the back USB connectors for devices that typically remain connected, such as printers and keyboards. |
| 6 | hard-drive activity light | The hard drive light is on when the computer reads data from or writes data to the hard drive. The light might also be on when a device such as your CD player is operating. |

- | | | |
|----|---------------------------|--|
| 7 | Dell™ rotatable badge | To rotate the Dell badge for tower-to-desktop conversion: remove the front panel (see "Removing the Front Panel" on page 155), turn it over, and rotate the plastic handle behind the badge. |
| 8 | power button, power light | Press the power button to turn on the computer. The light in the center of this button indicates power state. See "Diagnostic Lights" on page 121 for more information. |
| | | ➡ NOTICE: To avoid losing data, do not use the power button to turn off the computer. Instead, perform an operating system shutdown. |
| 9 | headphone connector | Use the headphone connector to attach headphones. |
| 10 | microphone connector | Use the microphone connector to attach a personal computer microphone for voice or musical input into a sound or telephony program. |
| 11 | network link light | The network link light is on when a good connection exists between a 10-Mbps, 100-Mbps, or 1000-Mbps (or 1-Gbps) network and the computer. |
| 12 | diagnostic lights (4) | Use these lights to help you troubleshoot a computer problem based on the diagnostic code. For more information, see "Diagnostic Lights" on page 121. |

Back View (Desktop Orientation)

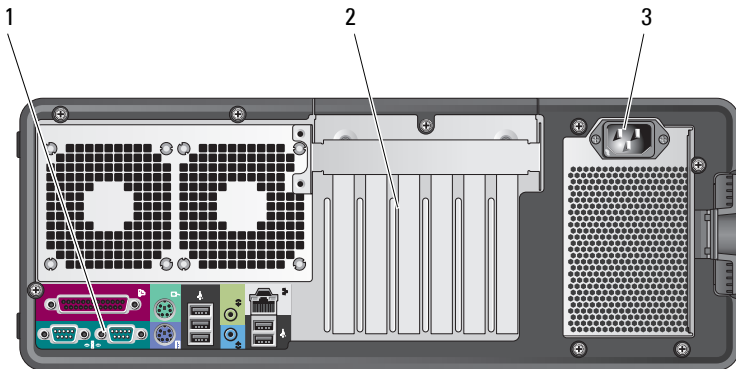

- | | | |
|---|-----------------------|--|
| 1 | back panel connectors | Plug serial, USB, and other devices into the appropriate connector. |
| 2 | card slots | <p>Access connectors for any installed PCI and PCI Express cards.</p> <p>Slots 2-4 support full-length cards:</p> <ul style="list-style-type: none"> • two PCI Express x16 slots • one PCI slot <p>Slots 1, 5, and 6 support half-length cards:</p> <ul style="list-style-type: none"> • two PCI-X slots • one PCI Express x8 slot |
| 3 | power connector | Insert the power cable. |

Inside View

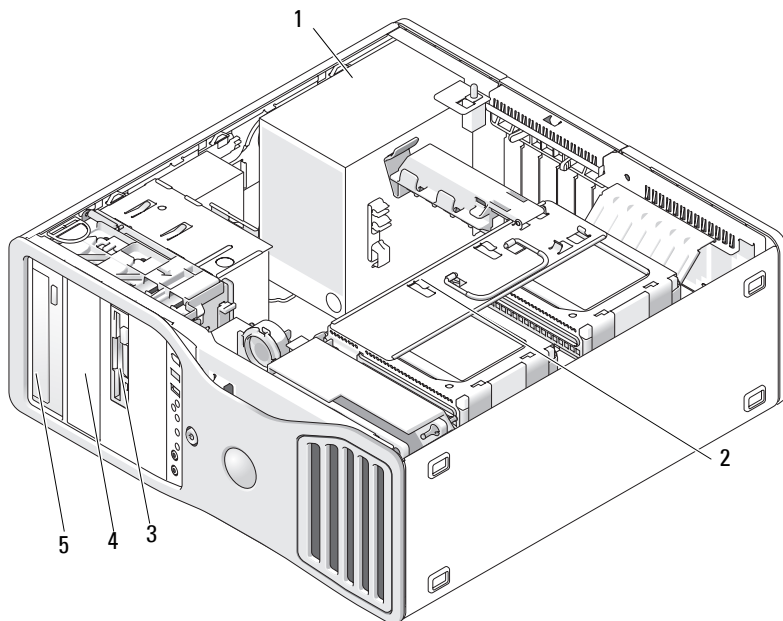

- | | | | |
|---|---------------------------|---|---------------------------|
| 1 | power supply | 2 | rotatable hard drive bay |
| 3 | FlexBay | 4 | lower 5.25-inch drive bay |
| 5 | upper 5.25-inch drive bay | | |

Inside View – Hard Drive Bay Rotated Out

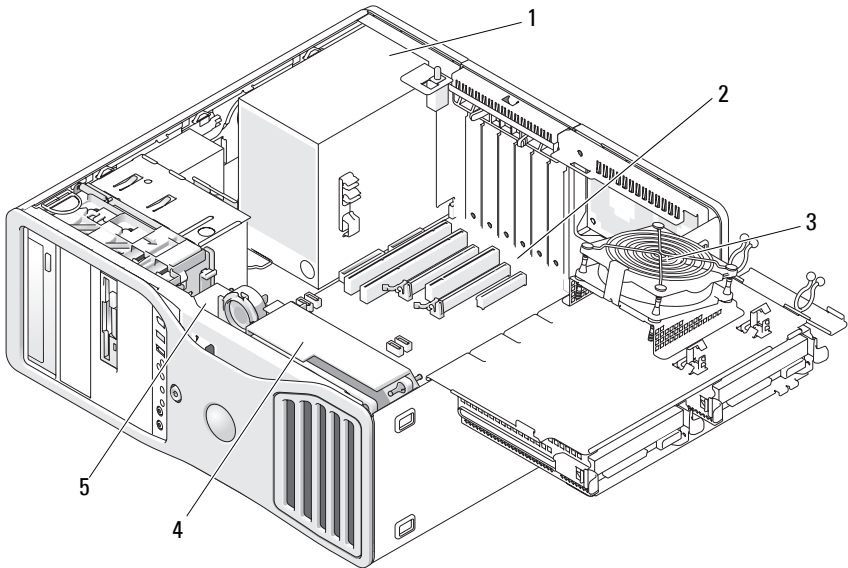

- | | | | | | |
|---|--------------|---|--------------|---|------------|
| 1 | power supply | 2 | system board | 3 | memory fan |
| 4 | front fan | 5 | card fan | | |

System Board Components

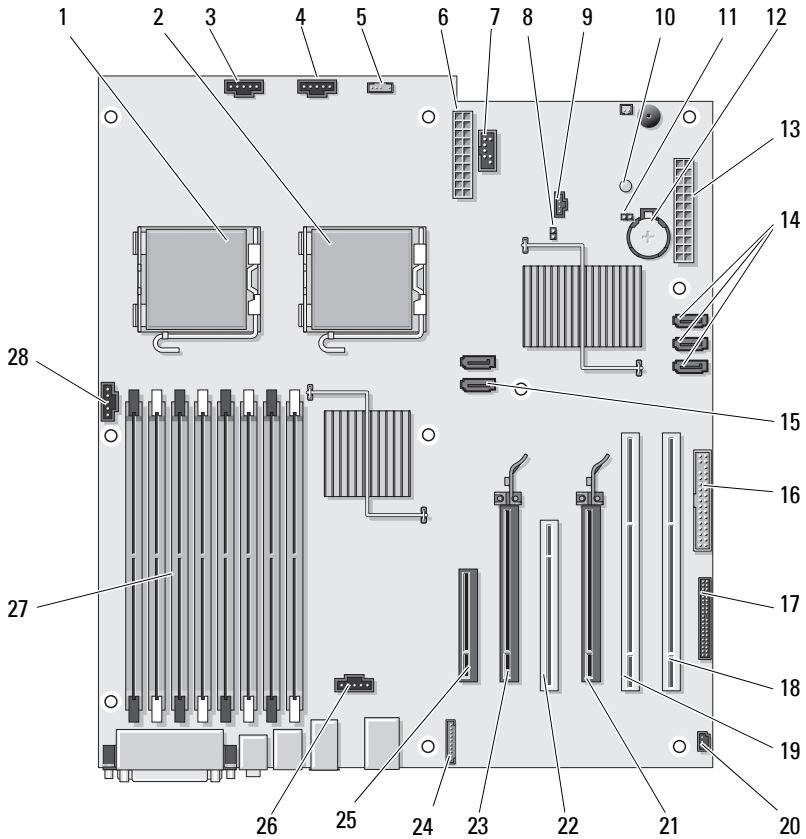





1	primary processor connector (CPU_0)	2	secondary processor connector (CPU_1)
3	front fan connector (FAN_FRONT)	4	card cage fan (FAN_CCAG)
5	internal speaker connector (INT_SPKR)	6	power connector (POWER2)
7	USB (INT_USB)	8	password jumper (PSWD)
9	auxiliary hard-drive LED connector (AUX_LED)	10	auxiliary power LED (AUX_PWR)
11	RTC reset jumper (RTRCRST)	12	battery socket (BATTERY)
13	main power connector (POWER1)	14	SATA connectors (SATA_2, SATA_3, and SATA_4)
15	SATA connectors (SATA_0, SATA_1)	16	floppy drive (DSKT)
17	front panel connector (FRONTPANEL)	18	PCI-X card slot (SLOT6_PCIX)
19	PCI-X card slot (SLOT5_PCIX)	20	chassis intrusion header (INTRUDER)
21	PCI Express 2.0 x16 card slot (SLOT4_PCIE)	22	PCI card slot (SLOT3_PCI)
23	PCI Express 2.0 x16 card slot (SLOT2_PCIE)	24	front panel audio connector (FP_AUDIO)
25	PCI Express x8 card slot, wired as x4 (SLOT1_PCIE)	26	hard drive fan connector (FAN_HDD)
27	memory module connectors (DIMM_1-8)	28	memory fan connector (FAN_MEM)

Cable Colors

Device	Color
SATA hard drive	blue cable
floppy drive	black pull tab
optical drive	orange cable
front panel	yellow pull tab

Changing Between Tower and Desktop Modes

-  **CAUTION:** Before you begin any of the procedures in this section, follow the safety instructions in the *Product Information Guide*.
-  **CAUTION:** To guard against electrical shock, always unplug your computer from the electrical outlet before opening the cover.
-  **NOTICE:** To prevent static damage to components inside your computer, discharge static electricity from your body before you touch any of your computer's electronic components. You can do so by touching an unpainted metal surface on the computer.
-  **NOTICE:** To avoid damage to a drive, do not set it on a hard surface. Instead, set the drive on a surface, such as a foam pad, that will sufficiently cushion it.
-  **NOTE:** To change your computer's orientation from either tower to desktop or desktop to tower, you must use an optional kit available from Dell. See "Product Information" on page 291 for more details on ordering from Dell.

With the purchase of an optional kit from Dell, you can change the configuration of your Dell Precision computer between desktop and tower modes.

-  **NOTE:** The tower configuration supports a third SAS or SATA hard drive in the FlexBay. The desktop configuration only supports a third SATA drive.

Tower Orientation



Desktop Orientation



- 1 Follow the procedures in "Before You Begin" on page 151.
- 2 Remove the computer cover (see "Removing the Computer Cover" on page 153).
- 3 If converting from a tower configuration to a desktop configuration, find the spare card retainer beside the card fan, pull its retention tab out from the surrounding metal and pull it up, away from the chassis.

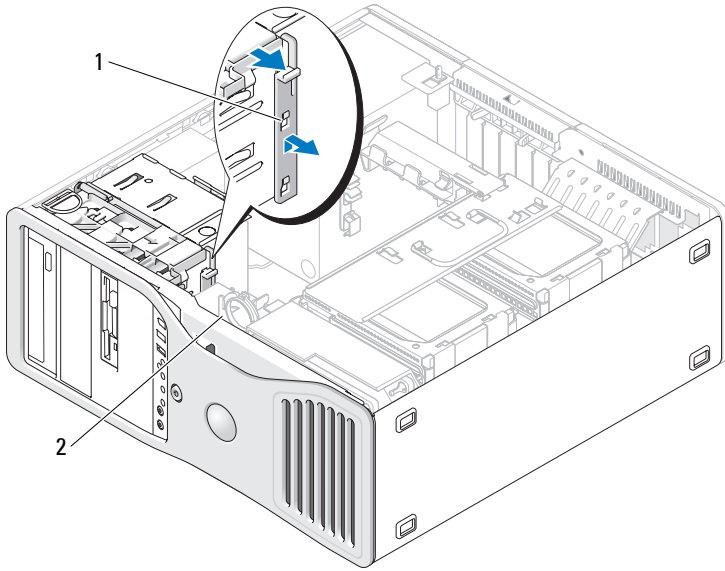

1 spare card retainer

2 card fan

- 4 Remove the drive panel (see "Removing the Drive Panel" on page 233).
- 5 Prepare the computer's new drive panel by adding or removing inserts as needed (see "Drive Panels" on page 233).

If spare screws are attached to the old drive panel, you may transfer them to the new drive panel.
- 6 If metal shields are present in your computer (see "About the Metal Shields Present in Some Drive Configurations" on page 207), pull to remove any metal shields from the optical bays or, in tower mode only, from the FlexBay.

Desktop Orientation

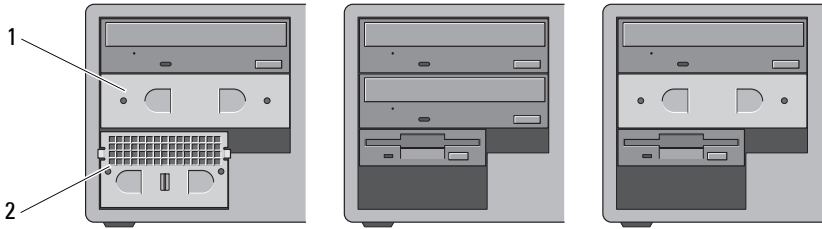

Tower Orientation

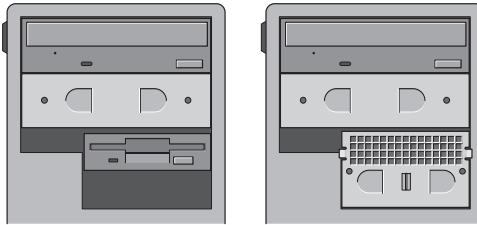

1 5.25-inch metal shield

2 vented metal insert

- 7** If metal shields are present in your computer and you are converting from desktop to tower mode (see "About the Metal Shields Present in Some Drive Configurations" on page 207), remove the vented metal insert from the FlexBay if the bay is empty or has an optional third hard drive installed in it:
- a** Pull the vented metal insert forward until its surface is flush with that of the surrounding chassis.
 - b** Rotate the bottom of the metal insert up towards you, disengaging its lower screws from the surrounding metal.
 - c** Lift the metal insert from the computer, disengaging its top screws and metal tabs from the surrounding metal.

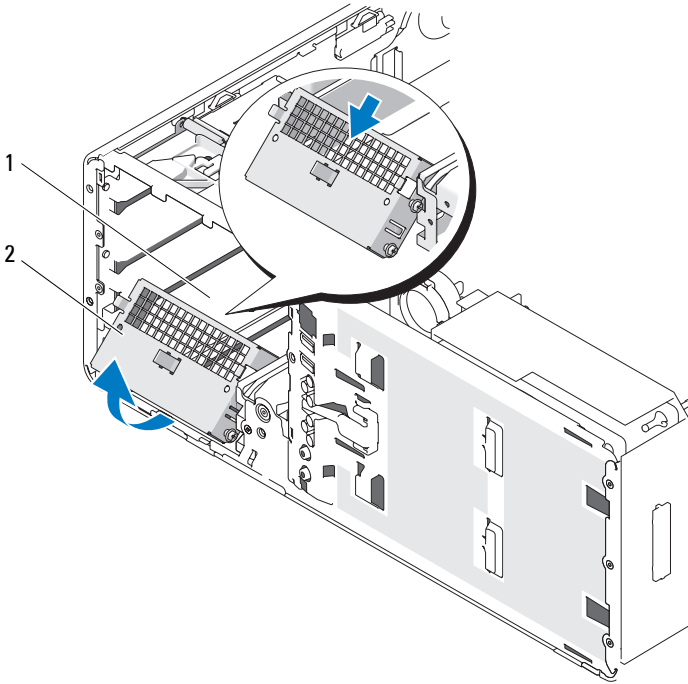

1 FlexBay

2 vented metal insert

- 8** Remove any drives installed in the optical drive bays (see "Optical Drive" on page 268).
- 9** If there is a drive installed in the Flexbay, remove it (see "Cards" on page 193).
- 10** Rotate the Dell badge by turning the plastic handle on the back of the front panel until the badge is in the correct orientation.
- 11** Reinstall any optical drives in the new orientation (see "Optical Drive" on page 268).
- 12** If you had a floppy drive or Media Card Reader installed in the FlexBay, reinstall it in the new orientation (see "Media Card Reader" on page 254).

- 13 If you had a hard drive installed in the 5.25-inch bay and you are changing from a desktop to a tower configuration, remove the hard drive from the drive carrier and install four screws into the front four holes on the sides of the heard drive.

If you had a hard drive installed in the FlexBay and you are changing from a tower to a desktop configuration, remove its four screws and install the hard drive into the drive carrier (see "Hard Drive" on page 212).



NOTE: Hard-drive screws or a hard-drive carrier can be ordered from Dell. See "Contacting Dell" on page 295.

- 14 If metal shields are present in your computer (see "About the Metal Shields Present in Some Drive Configurations" on page 207), replace metal shields in any empty optical drive bays or over the FlexBay, in tower mode only, by pressing them into place.
- 15 If a vented metal insert was installed over the FlexBay and you are converting from tower to desktop mode, reinstall it:
 - a Holding the metal insert at an angle, insert its two upper screws into the slot that runs along the inside of the FlexBay.
 - b Rotate the bottom of the vented metal insert down and insert its two bottom screws into the slot in the open area beneath the FlexBay.
 - c Push the vented metal insert until it clicks into place and its metal tabs rest flush against the chassis surface.

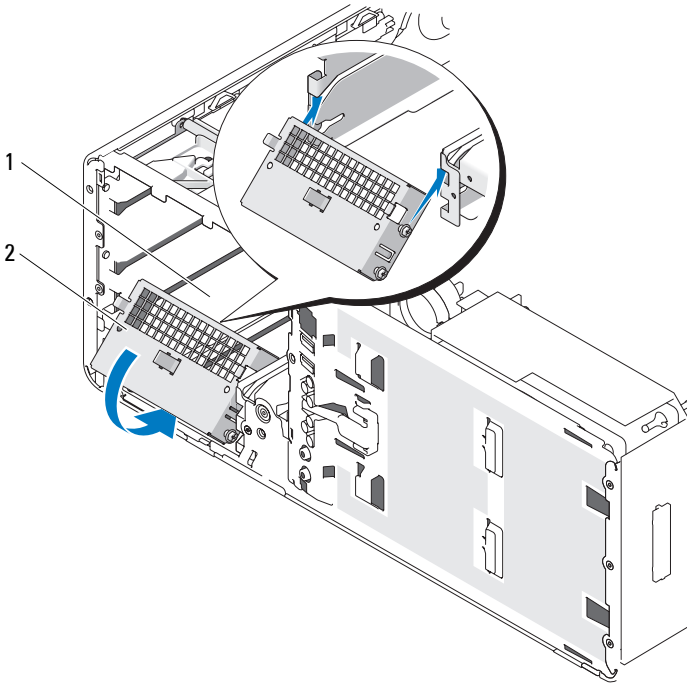

1 FlexBay

2 vented metal insert

- 16 Install the new drive panel (see "Replacing the Drive Panel" on page 237).
- 17 Replace the computer cover (see "Removing the Computer Cover" on page 153).
- 18 Verify that your computer works correctly by running the "Dell Diagnostics" on page 136.

Specifications



NOTE: Offerings may vary by region. For more information regarding the configuration of your computer, click **Start** → **Help and Support** and select the option to view information about your computer.

Processor	
Processor type	Dual-Core Intel® Xeon® Processor 5200 series Quad-Core Intel® Xeon® Processor 5400 series
Internal cache	Dual-Core Intel® Xeon® Processor 5200 series - 6 MB Quad-Core Intel® Xeon® Processor 5400 series - 12 MB
External bus frequency	1333 MHz

Memory	
Memory module connectors	8
Memory module capacities	512-MB or 1-, 2-, or 4-GB ECC
Memory type	667- MHz fully-buffered DDR2 SDRAM fully-buffered DIMMs (FBDs)  NOTICE: Full-length heat spreaders (FLHS) are required for all DIMMS.
Minimum memory	1 GB
Maximum memory	32 GB
BIOS address	F0000h

System Information	
System chipset	Intel 5400
Data bus width	64 bits
DRAM bus width	Quad-channel fully-buffered DIMM
Processor address bus width	38 Bits
Flash EPROM	8 Mbit
Graphics bus	two PCI Express 2.0 x16 slots

Expansion

Card support

Desktop Mode:

Slots 2-4 support full-length cards:

- two PCI Express x16 slots
- one PCI slot

Slots 1, 5, and 6 support half-length cards:

- two PCI-X slots
- one PCI Express x8 slot

Tower Mode:

Slots 2-5 support full-length cards:

- one PCI-X slot
- two PCI Express x16 slots
- one PCI slot

Slots 1 and 6 support half-length cards:

- one PCI-X slot
- one PCI Express x8 slot

Cards supported

PCI 2.3
PCI Express 1.0A in slot 1
PCI Express 2.0 x16 in slots 2 and 4
PCI-X 2.0A

PCI

connector	one
connector size	120 pins
connector data width (maximum)	32 bits
bus transfer rate	133 MB/s

PCI-X

connectors	two
connector size	188 pins
connector data width (maximum)	64 bits
bus transfer rate	800 MB/s

Expansion

PCI Express x8 wired as x4 (SLOT1_PCIE)

connectors	one x8 (supports x8, x4, and x1 modes/cards; maximum x4 link width)
connector size	98 pins
connector data width (maximum)	4 PCI Express lanes
bus transfer rate	2.5 GB/s/lane/direction (raw bandwidth)

PCI Express 2.0 x16

connector	two x16 slots (support x16, x8, x4 and x1 modes/cards)
connector size	164 pins
connector data width (maximum)	16 PCI Express lanes
bus transfer rate	5 GB/s/lane/direction (raw bandwidth)

Ports and Connectors

External connectors

Serial	two 9-pin connectors; 16550C-compatible
Parallel	25-hole connector (bidirectional)
IEEE 1394 (optional)	one front-panel 6-pin connector and one rear panel 6-pin connector
Network adapter	RJ45 connector
PS/2 (keyboard and mouse)	two 6-pin mini-DIN
USB	two front-panel and five back-panel USB 2.0-compliant connectors
Audio	two front-panel connectors for microphone and headphones; two back-panel connectors for line-in and line-out

System board connectors

Floppy drive	34-pin connector
--------------	------------------

Ports and Connectors *(continued)*

Serial ATA	five 7-pin connectors
Internal USB	one 10-pin connector for optional Media Card Reader (3.5-inch bay device) or secure boot device

Video

Video type	PCI Express 2.0 x16 (two slots)
------------	---------------------------------

Audio

Audio type	High Definition Audio CODEC and Azalia/ High Definition digital controller
Stereo conversion	24-bit analog-to-digital; 24-bit digital-to-analog

Drives

Externally accessible	one 3.5-inch drive bay (FlexBay) two 5.25-inch drive bays
Internally accessible	two 3.5-inch hard-drive bays

Key Combinations

<F2>	starts embedded system setup (during start-up only)
<F12> or <Ctrl> <Alt> <F8>	starts the Boot Device menu (during start-up only)
<Ctrl> <Alt> <F10>	launches the utility partition (if installed) during start-up
<F5>	runs onboard diagnostics

Controls and Lights

Power control	push button
---------------	-------------

Controls and Lights

Power light	Front panel: green light—blinking green in sleep state; solid green for power-on state amber light—blinking amber indicates that an internal power problem might exist; solid amber indicates that a device may be malfunctioning or incorrectly installed (see "Power Problems" on page 116)
Hard-drive access light	Front panel: green light - on when the computer reads data from or writes data to the hard drive. The light may also be on when a device such as the optical drive is operating.
Network integrity lights	Back panel: green light for 10-Mb operation; orange light for 100-Mb operation; yellow light for a 1000-Mb (1-Gb) operation Front panel: displays solid green when a network connection is present.
Activity light	Back panel: yellow blinking light when there is network activity.
Diagnostic lights	Front panel: four lights (see "Diagnostic Lights" on page 121)
Standby power light	AUX_PWR on the system board

Power

DC power supply	
Wattage	875 W
Heat dissipation	1094W or 3732BTU/hour  NOTE: Heat dissipation is calculated based upon the power supply wattage rating.
Voltage	auto-sensing power supply—90 V to 265 V at 50/60 Hz
Backup battery	3-V CR2032 lithium coin cell

Physical

Height	44.8 cm (17.6 inches)
Width	17.1 cm (6.8 inches)
Depth	46.7 cm (18.4 inches)
Weight	17.7 kg (39 lb)
Supported monitor weight (in desktop orientation)	45.4 kg (100 lb)

Environmental

Temperature range

Operating	10° to 35°C (50° to 95°F)
Storage	-40° to 65°C (-40° to 149°F)

Relative humidity (maximum)

Operating	20% to 80% (noncondensing)
Storage	5% to 95% (noncondensing)

Maximum vibration (using a random-vibration spectrum that simulates user environment)

Operating	5 to 350 Hz at 0.0002 G ² /Hz
Storage	5 to 500 Hz at 0.001 to 0.01 G ² /Hz

Maximum shock

Operating	40 G +/- 5% with pulse duration of 2 msec +/- 10% (equivalent to 20 in/sec [51 cm/sec])
Storage	105 G +/- 5% with pulse duration of 2 msec +/- 10% (equivalent to 50 in/sec [127 cm/sec])

Altitude (maximum)

Operating	-15.2 to 3048 m (-50 to 10,000 ft)
Storage	-15.2 to 10,668 m (-50 to 35,000 ft)

Advanced Features

LegacySelect Technology Control

LegacySelect technology control offers legacy-full, legacy-reduced, or legacy-free solutions based on common platforms, hard-drive images, and help desk procedures. Control is provided to the administrator through system setup, Dell OpenManage™ IT Assistant, or Dell custom factory integration.

LegacySelect allows administrators to electronically activate or deactivate connectors and media devices that include serial and USB connectors, a parallel connector, a floppy drive, PCI slots, and a PS/2 mouse. Connectors and media devices that are deactivated make resources available. You must restart the computer to effect the changes.

Manageability

Alert Standard Format

Alert Standard Format (ASF) is a DMTF management standard that specifies "pre-operating system" or "operating system-absent" alerting techniques. The standard is designed to generate an alert on potential security and fault conditions when the operating system is in a sleep state or the computer is powered down. ASF is designed to supersede previous operating system-absent alerting technologies.

Your computer supports the following ASF alerts:

Alert	Description
Chassis: Chassis Intrusion - Physical Security Violation/ Chassis Intrusion - Physical Security Violation Event Cleared	The computer chassis has been opened or the chassis intrusion alert has been cleared.
Boot: Failure to Boot to BIOS	The BIOS did not complete loading upon initiation.
Password: System Password Violation	The system password is invalid (alert occurs after three failed attempts).
CPU: CPU DOA Alert/CPU DOA Alert Cleared	The processor is not functioning.
Heartbeats: Entity Presence	Periodic heartbeats have been transmitted to verify system presence.
Temperature: Generic Critical Temperature Problem	The computer temperature is out of limits.
Voltage: Generic Critical Voltage Problem	The voltage from integrated voltage regulators is out of limits.
Power Supply: Critical Power Supply Problem	The computer power supply voltage is out of limits.
Cooling Device: Generic Critical Fan Failure	The fan speed (rpm) is out of limits.
Connectivity: Ethernet Connectivity Enabled/ Ethernet Connectivity Disabled	The Ethernet connectivity is enabled or the Ethernet connectivity is disabled.

For more information about Dell's ASF implementation, see the *ASF User's Guide* and the *ASF Administrator's Guide*, which are available on the Dell Support website at support.dell.com.

Dell OpenManage™ IT Assistant

IT Assistant configures, manages, and monitors computers and other devices on a corporate network. IT Assistant manages assets, configurations, events (alerts), and security for computers equipped with industry-standard management software. It supports instrumentation that conforms to SNMP, DMI, and CIM industry standards.

Dell OpenManage Client instrumentation, which is based on DMI and CIM, is available for your computer. For information on IT Assistant, see the *Dell OpenManage IT Assistant User's Guide* available on the Dell Support website at support.dell.com.

Dell OpenManage Client Instrumentation

Dell OpenManage Client Instrumentation is software that enables remote management programs, such as IT Assistant, to do the following:

- Access information about your computer, such as how many processors it has and what operating system it is running.
- Monitor the status of your computer, such as listening for thermal alerts from temperature probes or hard-drive failure alerts from storage devices.
- Change the state of your computer, such as updating its BIOS or shutting it down remotely.

A managed system is one that has Dell OpenManage Client Instrumentation set up on a network that uses IT Assistant. For information about Dell OpenManage Client Instrumentation, see the *Dell OpenManage Client Instrumentation User's Guide* available on the Dell Support website at support.dell.com.

Power Management

Your computer can be set to use less power when you are not working. You control the power usage through the operating system installed on your computer and certain option settings in system setup (see "Power Management" on page 47). These periods of reduced power are called "sleep modes."



NOTE: All components installed in the computer must support the hibernate and/or standby mode feature(s) and have the appropriate drivers loaded to enter either of these sleep modes. For more information, see the manufacturer's documentation for each component.

- **Standby.** In this sleep mode, power is reduced or turned off for many components. However, system memory remains active.



NOTE: Hibernate mode is only supported on computers with 4-GB of RAM or less.

- **Hibernate.** This sleep mode reduces power consumption to a minimum by writing all data in system memory to a hard drive and then removing system power. Waking up from this mode restarts the computer, and the memory contents are restored. Operation then resumes where the computer left off when it entered the hibernation mode.
- **Shutdown.** This sleep mode removes all power from the computer except a small auxiliary amount. As long as the computer remains connected to an electrical outlet, it can be automatically or remotely started. For example, the **Auto Power On** option in system setup (see "Power Management" on page 47) allows the computer to automatically start at a specified time. Also, your network administrator can remotely start your computer using a power management event such as Remote Wake Up.

The following table lists the sleep modes and the methods you can use to wake the computer from each mode.

Sleep Mode	Wake-Up Methods (Windows XP)
Standby	<ul style="list-style-type: none"> • Press the power button • Auto power on • Move or click the mouse • Type on the keyboard • USB device activity • Power management event
Hibernate	<ul style="list-style-type: none"> • Press the power button • Auto power on • Power management event
Shutdown	<ul style="list-style-type: none"> • Press the power button • Auto power on • Power management event



NOTE: For more information on power management, see your operating system documentation.

Hyperthreading and Multi-Core Technology

Hyperthreading is an Intel technology that can enhance overall computer performance by allowing one physical processor to function as two logical processors that are capable of performing certain tasks simultaneously. Multi-core processors contain two or more physical computational units inside a single CPU package, thereby increasing computing efficiency and multi-tasking ability. Intel has implemented this technology in its Dual-Core and Quad-Core processors. These processors have two and four computational units respectively. It is recommended that you use the Microsoft Windows XP Service Pack 1 (SP1) or higher or Windows Vista operating systems which are optimized to take advantage of these technologies.

While many programs can benefit from hyperthreading and multi-core technology, some programs may have not been optimized for them and may require an update from the software manufacturer. Contact the software manufacturer for updates and information about using hyperthreading or multi-core technology with your software. To determine if your computer is using hyperthreading technology, check the system setup option for hyperthreading under the Performance tab (see "System Setup" on page 290).

About RAID Configurations

This section provides an overview of the RAID configuration that you might have selected when you purchased your computer. While there are many RAID configurations available in the computer industry for different types of uses, Dell offers RAID level 0, RAID level 1, or RAID level 5 on your Dell Precision computer.

A RAID level 0 configuration is recommended for high-performance programs, and a RAID level 1 configuration is recommended for users that desire a high level of data integrity. A RAID level 5 configuration provides for both data integrity and high performance. RAID levels do not represent a hierarchy. A RAID level 5 configuration is not inherently better or worse than a RAID level 0 configuration.

The Intel RAID controller on your computer can only create a RAID level 0 configuration using two or three physical drives. If a third drive is present, then that drive can be made part of a RAID level 0 configuration using the

Intel RAID configuration program. If you have three drives and two are in a RAID level 1 configuration, the third drive can be used as a spare drive for the RAID configuration (see "Creating a Spare Hard Drive" on page 60). A RAID level 5 array must be made up of three drives.

All drives must be the same type of drive; SAS and SATA drives cannot be mixed in a RAID array. The drives should also be the same size to ensure that the larger drive does not contain unallocated (and therefore unusable) space.

RAID Level 0

RAID level 0 uses a storage technique known as "data striping" to provide a high data access rate. Data striping is a method of writing consecutive segments—or stripes—of data sequentially across the physical drives to create a large virtual drive. Data striping allows one of the drives to read data while the other drive is searching for and reading the next block.

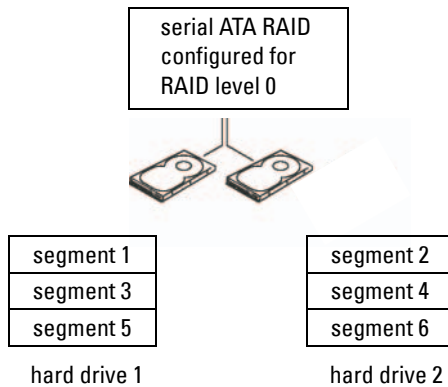

Another advantage of a RAID level 0 configuration is that it utilizes the full capacities of the drives. If you have two 120-GB drives installed, you have 240 GB on which to store data.

➡ NOTICE: Because RAID level 0 provides no data redundancy, if one drive fails, then the data on the other drive is also inaccessible. Therefore, ensure that you perform regular backups when you use a RAID level 0 configuration.

RAID Level 1

RAID level 1 uses a data-redundancy storage technique known as "mirroring." When data is written to the primary drive, the data is then duplicated—or mirrored—on the other drive. A RAID level 1 configuration sacrifices high-data access rates for its data redundancy advantages.

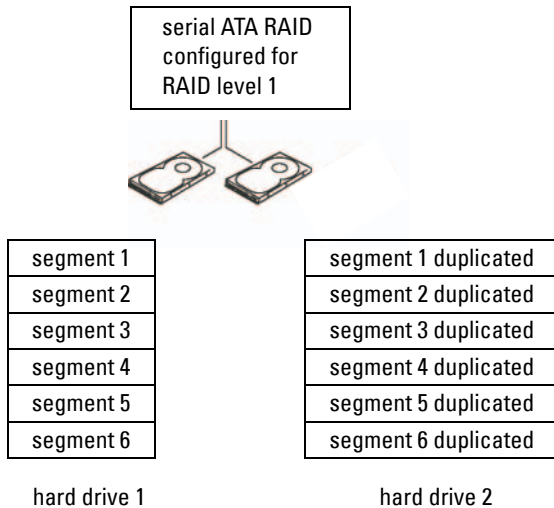

If a drive failure occurs, subsequent read and write operations are directed to the surviving drive. A replacement drive can then be rebuilt using the data from the surviving drive. Also, because data is duplicated on both drives, two 120-GB RAID level 1 drives collectively have a maximum of 120-GB on which to store data.

RAID Level 5

RAID level 5 uses a data-staging storage technique known as "parity checking." When a block of data is written to the RAID configuration, it is striped across all of the drives in the RAID array except for one drive, to which is written parity data. The parity data is information that allows for the entire block of striped data to be calculated if one of the drives fails.

Since parity data is fairly small when compared to the size of the actual stored data, the equivalent of one hard drive can serve as a parity drive for any number of data-storing hard drives. However, not all of the parity data is put on the same drive. Instead, with each new block of data written to the RAID configuration, the different drives alternately act as either data-storing or parity drives.

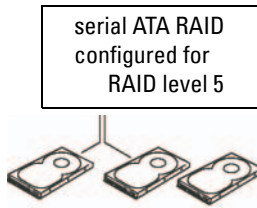

half of data block 1	half of data block 1	parity data for block 1
half of data block 2	parity data for block 2	half of data block 2
parity data for block 3	half of data block 3	half of data block 3
half of data block 4	parity data for block 4	half of data block 4
half of data block 5	half of data block 5	parity data for block 5
parity data for block 6	half of data block 6	half of data block 6
hard drive 1	hard drive 2	hard drive 3

Because data is striped across the RAID configuration, as it is in a RAID 0 configuration, it can be quickly accessed. Also, because of the parity data, if only a single drive fails, that drive can be rebuilt using the parity data on the other drives. The amount of storage space available to three 120-GB RAID level 5 drives is 240-GB on which to store data, since the equivalent of one drive is set aside for parity data. A minimum of three drives is required to create a RAID level 5 configuration.

Configuring Your Computer for RAID

At some point you may want to configure your computer for RAID if you did not select a RAID configuration when you purchased your computer. You must have at least two hard drives installed in your computer to set up a RAID configuration. For instructions on how to install a hard drive, see "Cards" on page 193.

To configure a RAID hard drive volume, use the Intel RAID Option ROM utility *before* you install the operating system onto the hard drive. You must set your computer to RAID-enabled mode before starting any of the RAID configuration procedures in this document.

Setting Your Computer to RAID-Enabled Mode



NOTE: This procedure is only possible if you ordered your computer with a RAID configuration.

- 1 Enter the system setup program (see "System Setup" on page 89).
- 2 Press the up- and down-arrow keys to highlight **Drives**, and press <Enter>.
- 3 Press the up- and down-arrow keys to highlight **SATA Operation**, and press <Enter>.
- 4 Press the left- and right-arrow keys to highlight **RAID Autodetect /AHCI or RAID Autodetect/ ATA**, according to your preferences; press <Enter>, and then press <Esc>.

For more information about RAID options, see "System Setup Options" on page 89.

- 5 Press the left- and right-arrow keys to highlight **Save/Exit**, and press <Enter> to exit system setup and resume the boot process.

Configuring Your Computer for RAID Using the Intel Matrix Storage Manager



NOTE: This procedure is only possible if you ordered your computer with a RAID configuration.

If you already have one hard drive with the operating system installed on it, and you want to add a second hard drive and reconfigure both drives into a RAID volume without losing the existing operating system and any data, you need to use the migrating option for a RAID level 0 configuration (see

"Migrating to a RAID Level 0 Configuration" on page 57), a RAID level 1 configuration (see "Migrating to a RAID Level 1 Configuration" on page 58), or a RAID level 5 configuration (see "Migrating to a RAID Level 5 Configuration" on page 59). Create a new volume only when:

- You are adding two new drives to an existing single-drive computer (and the operating system is on the single drive), and you want to configure the two new drives into a RAID volume.
- You already have a two-hard drive computer configured into a volume, but you still have some space left on the volume that you want to designate as a second RAID volume.

Creating a RAID Level 0 Configuration



NOTICE: When you perform this operation, all data on the RAID drives will be lost.



NOTE: This procedure is only possible if you ordered your computer with a RAID configuration.

- 1 Set your computer to RAID-enabled mode (see "Setting Your Computer to RAID-Enabled Mode" on page 53).
- 2 Click **Start** and point to **Programs**→ **Intel(R) Matrix Storage Manager**→ **Intel Matrix Storage Console** to launch the Intel Storage Utility.

If you do not see an **Actions** menu option, you have not yet set your computer to RAID-enabled mode (see "Setting Your Computer to RAID-Enabled Mode" on page 53).

- 3 On the **Actions** menu, select **Create RAID Volume** to launch the Create RAID Volume Wizard, and then click **Next**.
- 4 On the **Select Volume Location** screen, click the first hard drive you want to include in your RAID level 0 volume, and then click the right arrow.
- 5 Click a second hard drive. To add a third hard drive in your RAID level 0 volume, click the right arrow and click on the third drive until three drives appear in the **Selected** window, and then click **Next**.
- 6 In the **Specify Volume Size** window, click the **Volume Size** desired, and then click **Next**.
- 7 Click **Finish** to create the volume, or click **Back** to make changes.

Creating a RAID Level 1 Configuration



NOTICE: When you perform this operation, all data on the RAID drives will be lost.



NOTE: This procedure is only possible if you ordered your computer with a RAID configuration.

- 1 Set your computer to RAID-enabled mode (see "Setting Your Computer to RAID-Enabled Mode" on page 53).
- 2 Click the **Start** button and point to **Programs**→**Intel(R) Matrix Storage Manager**→**Intel Matrix Storage Console** to launch the Intel® Storage Utility.

If you do not see an **Actions** menu option, you have not yet set your computer to RAID-enabled mode (see "Setting Your Computer to RAID-Enabled Mode" on page 53).

- 3 On the **Actions** menu, select **Create RAID Volume** to launch the Create RAID Volume Wizard.
- 4 Click **Next** at the first screen.
- 5 Confirm the volume name, select **RAID 1** as the RAID level, and then click **Next** to continue.
- 6 On the **Select Volume Location** screen, click the first hard drive you want to use to create your RAID level 1 volume, and then click the right arrow. Click a second hard drive until two drives appear in the **Selected** window, and then click **Next**.
- 7 In the **Specify Volume Size** window, select the **Volume Size** desired and click **Next**.
- 8 Click **Finish** to create the volume, or click **Back** to make changes.
- 9 Follow Microsoft Windows procedures for creating a partition on the new RAID volume.

Creating a RAID Level 5 Configuration



NOTICE: When you perform this operation, all data on the RAID drives will be lost.



NOTE: This procedure is only possible if you ordered your computer with a RAID configuration.

- 1 Set your computer to RAID-enabled mode (see "Setting Your Computer to RAID-Enabled Mode" on page 53).

- 2 Click the **Start** button and point to **Programs→ Intel(R) Matrix Storage Manager→ Intel Matrix Storage Console** to launch the Intel Storage Utility.
- 3 If you do not see an **Actions** menu option, you have not yet set your computer to RAID-enabled mode (see "Setting Your Computer to RAID-Enabled Mode" on page 53).
- 4 On the **Actions** menu, select **Create RAID Volume** to launch the Create RAID Volume Wizard.
- 5 Click **Next** at the first screen.
- 6 Confirm the volume name, select **RAID 5** as the RAID level, and then click **Next** to continue.
- 7 On the **Select Volume Location** screen, click the first hard drive you want to use to create your RAID level 5 volume, and then click the right arrow. Click two or three additional drives until either three or four drives appear in the **Selected** window, and then click **Next**.
- 8 In the **Specify Volume Size** window, select the **Volume Size** desired and click **Next**.
- 9 Click **Finish** to create the volume, or click **Back** to make changes.
- 10 Follow Microsoft Windows procedures for creating a partition on the new RAID volume.

Deleting a RAID Volume

-  **NOTICE:** While this procedure deletes the RAID 1 volume, it also splits the RAID 1 volume into two non-RAID hard drives with a partition, and leaves any existing data files intact. Deleting a RAID 0 or 5 volume, however, destroys all data on the volume.
- 1 Click the **Start** button and point to **Programs→ Intel(R) Matrix Storage Manager→ Intel Matrix Storage Console** to launch the Intel Storage Utility.
 - 2 Right-click the **Volume** icon of the RAID volume you want to delete, and select **Delete Volume**.
 - 3 On the **Delete RAID Volume Wizard** screen, click **Next**.
 - 4 Highlight the RAID volume you want to delete in the **Available** box, click the right-arrow button to move the highlighted RAID volume into the **Selected** box, and then click **Next**.

- 5 Click **Finish** to delete the volume.

About Migrating to a RAID Configuration

Migration is only possible from a factory-installed RAID configuration, if when you ordered your system it was configured for RAID and if you are migrating between certain RAID configurations.

	2-drive RAID 0	3-drive RAID 0	2-drive RAID 1	3-drive RAID 5
2-drive RAID 0	Not applicable	2- to 3-drive migration possible	Not possible	Not possible
3-drive RAID 0	Not possible	Not applicable	Not possible	Not possible
2-drive RAID 1	RAID 1 to RAID 0 migration possible	RAID 1 to RAID 0 migration possible	Not applicable	RAID 1 to RAID 5 migration possible
3-drive RAID 5	Not possible	Not possible	Not possible	Not applicable

Migrating to a RAID Level 0 Configuration

- 1 Set your computer to RAID-enabled mode (see "Setting Your Computer to RAID-Enabled Mode" on page 53).
- 2 Click the **Start** button and point to **All Programs**→ **Intel(R) Matrix Storage Manager**→ **Intel Matrix Storage Console** to launch the Intel Storage Utility.

If you do not see an **Actions** menu option, you have not yet set your computer to RAID-enabled mode (see "Setting Your Computer to RAID-Enabled Mode" on page 53).
- 3 On the **Actions** menu, select **Create RAID Volume From Existing Hard Drive** to launch the Migration Wizard.
- 4 Click **Next** on the Migration Wizard screen.
- 5 Enter a RAID volume name or accept the default.
- 6 From the drop-down box, select **RAID 0** as the RAID level.

Select the strip size closest to the size of the average file you want to store on the RAID volume. If you do not know the average file size, choose 128 KB as your strip size.

- 7 Select the appropriate strip size from the drop-down box, and then click **Next**.

Select the hard drive that you want to use as your source hard drive (it should be the hard drive containing the data or operating system files that you want to keep on the RAID volume).

- 8 On the **Select Source Hard Drive** screen, double-click the hard drive from which you want to migrate, and click **Next**.
- 9 On the **Select Member Hard Drive** screen, double-click the hard drive(s) to select the member drive(s) to span the stripe array, and click **Next**.
- 10 On the **Specify Volume Size** screen, select the **Volume Size** you want, and click **Next**.

 **NOTICE:** In step 11, all data contained on the member drive will be removed.

- 11 Click **Finish** to start migrating, or click **Back** to make changes. You can use your computer normally during the migration process.

Migrating to a RAID Level 1 Configuration

- 1 Set your computer to RAID-enabled mode (see "Setting Your Computer to RAID-Enabled Mode" on page 53).
- 2 Click the **Start** button and point to **All Programs**→ **Intel(R) Matrix Storage Manager**→ **Intel Matrix Storage Console** to launch the Intel Storage Utility.

If you do not see an **Actions** menu option, you have not yet set your computer to RAID-enabled mode (see "Setting Your Computer to RAID-Enabled Mode" on page 53).

- 3 On the **Actions** menu, click **Create RAID Volume From Existing Hard Drive** to launch the Migration Wizard.
- 4 Click **Next** on the first Migration Wizard screen.
- 5 Enter a RAID volume name or accept the default.
- 6 From the drop-down box, select **RAID 1** as the RAID level.

Select the hard drive that you want to use as your source hard drive (it should be the hard drive containing the data or operating system files that you want to keep on the RAID volume).

- 7 On the **Select Source Hard Drive** screen, double-click the hard drive from which you want to migrate, and click **Next**.
- 8 On the **Select Member Hard Drive** screen, double-click the hard drive to select the member drive that you want to act as the mirror in the configuration, and click **Next**.
- 9 On the **Specify Volume Size** screen, select the volume size you want, and click **Next**.



NOTICE: In step 10, all data contained on the member drive will be removed.

- 10 Click **Finish** to start migrating, or click **Back** to make changes. You can use your computer normally during migration process.

Migrating to a RAID Level 5 Configuration

- 1 Set your computer to RAID-enabled mode (see "Setting Your Computer to RAID-Enabled Mode" on page 53).
- 2 Click the **Start** button and point to **All Programs**→ **Intel(R) Matrix Storage Manager**→ **Intel Matrix Storage Console** to launch the Intel Storage Utility.

If you do not see an **Actions** menu option, you have not yet set your computer to RAID-enabled mode (see "Setting Your Computer to RAID-Enabled Mode" on page 53).

- 3 On the **Actions** menu, click **Create RAID Volume From Existing Hard Drive** to launch the Migration Wizard.
- 4 Click **Next** on the first Migration Wizard screen.
- 5 Enter a RAID volume name or accept the default.
- 6 From the drop-down box, select **RAID 5** as the RAID level.

Select the hard drive that you want to use as your source hard drive (it should be the hard drive containing the data or operating system files that you want to keep on the RAID volume).

- 7 On the **Select Source Hard Drive** screen, double-click the hard drive from which you want to migrate, and click **Next**.

- 8 On the **Select Member Hard Drive** screen, double-click the two or three drives to select the member drives that you want to use in the configuration, and click **Next**.
- 9 On the **Specify Volume Size** screen, select the volume size you want, and click **Next**.
-  **NOTICE:** In step 10, all data contained on the member drive will be removed.
- 10 Click **Finish** to start migrating, or click **Back** to make changes. You can use your computer normally during migration process.

Creating a Spare Hard Drive

-  **NOTICE:** A spare hard drive must be at least the same size as the larger of the two drives in the RAID configuration that it supports. Otherwise, the spare hard drive will not function. The RAID utility will not notify you if you fail to select a large enough drive.

A spare hard drive may be created with a RAID level 1 configuration. The spare hard drive will not be recognized by the operating system, but you will be able to see the spare drive from within Disk Manager or the Intel RAID Option ROM utility. When a member of the RAID level 1 configuration is broken, the computer automatically rebuilds the mirror configuration using the spare hard drive as the broken member's replacement.

To mark a drive as a spare hard drive:

- 1 Click the **Start** button and point to **Programs**→**Intel(R) Matrix Storage Manager**→**Intel Matrix Storage Console** to launch the Intel Storage Utility.
- 2 Right-click the hard drive you want to mark as a spare hard drive.
- 3 Click **Mark as Spare**.

To remove spare marking from a spare hard drive:

- 1 Right-click the spare hard-drive icon.
- 2 Click **Reset Hard Drive to Non-RAID**

Rebuilding a Degraded RAID Level 1 or 5 Configuration

If your computer does not have a spare hard drive, and the computer has reported a degraded RAID level 1 or 5 volume, you can manually rebuild the computer's redundancy mirror to a new hard drive:

- 1 Click the **Start** button and point to **Programs**→**Intel(R) Matrix Storage Manager**→**Intel Matrix Storage Console** to launch the Intel Storage Utility.
- 2 Right-click the available hard drive to which you want to rebuild the RAID level 1 or 5 volume, and click **Rebuild to this Disk**.
- 3 You can use your computer while the computer is rebuilding the RAID level 1 or 5 volume.

Configuring Your Computer for RAID Using the Intel® RAID Option ROM Utility

- ➔ **NOTICE:** You will lose any data on your hard drives when you create a RAID configuration using the following procedure. Back up data that you want to keep before continuing.
- ➔ **NOTICE:** Use the following procedure only if you are reinstalling your operating system. Do not use the following procedure to migrate an existing storage configuration to RAID level 0 configuration.

Creating a RAID Level 0 Configuration

- ➔ **NOTICE:** You will lose any data on your hard drives when you create a RAID configuration using the following procedure. Back up data that you want to keep before continuing.
- 1 Set your computer to RAID-enabled mode (see "Setting Your Computer to RAID-Enabled Mode" on page 53).
 - 2 Press <Ctrl><i> when you are prompted to enter the Intel RAID Option ROM utility.
 - 3 Press the up- and down-arrow keys to highlight **Create RAID Volume**, and press <Enter>.
 - 4 Enter a RAID volume name or accept the default, and press <Enter>.
 - 5 Press the up- and down-arrow keys to select **RAID0(Stripe)**, and press <Enter>.
 - 6 If more than two hard drives are available, press the up- and down-arrow keys and spacebar to select the two or three drives that you want to use to make up your configuration, and then press <Enter>.

Select the strip size closest to the size of the average file that you want to store on the RAID volume. If you do not know the average file size, choose 128 KB as your strip size.

- 7 Press the up- and down-arrow keys to change the strip size and press <Enter>.
- 8 Select the desired capacity for the volume and press <Enter>. The default value is the maximum available size.
- 9 Press <Enter> to create the volume.
- 10 Press <y> to confirm that you want to create the RAID volume.
- 11 Confirm that the correct volume configuration is displayed on the main Intel RAID Option ROM utility screen.
- 12 Press the up- and down-arrow keys to select **Exit** and press <Enter>.
- 13 Install the operating system (see "Reinstalling Windows XP or Windows Vista" on page 149.)

Creating a RAID Level 1 Configuration



NOTICE: You will lose any data on your hard drives when you create a RAID configuration using the following procedure. Back up data that you want to keep before continuing.

- 1 Set your computer to RAID-enabled mode (see "Setting Your Computer to RAID-Enabled Mode" on page 53).
- 2 Press <Ctrl><i> when you are prompted to enter the Intel RAID Option ROM utility.
- 3 Use the up- and down-arrow keys to highlight **Create RAID Volume** and press <Enter>.
- 4 Enter a RAID volume name or accept the default and press <Enter>.
- 5 Use the up- and down-arrow keys to select **RAID1(Mirror)** and press <Enter>.
- 6 If there are more than two hard drives available, press the up- and down-arrow keys and spacebar to select the two drives you want to use to make up your volume, and then press <Enter>.
- 7 Select the desired capacity for the volume, and press <Enter>. The default value is the maximum available size.

- 8 Press <Enter> to create the volume.
- 9 Press <y> to confirm that you want to create the RAID volume.
- 10 Confirm that the correct volume configuration is displayed on the main Intel RAID Option ROM utility screen.
- 11 Use the up- and down-arrow keys to select **Exit** and press <Enter>.
- 12 Install the operating system (see "Reinstalling Windows XP or Windows Vista" on page 149.)

Creating a RAID Level 5 Configuration



NOTICE: You will lose any data on your hard drives when you create a RAID configuration using the following procedure. Back up data that you want to keep before continuing.

- 1 Set your computer to RAID-enabled mode (see "Setting Your Computer to RAID-Enabled Mode" on page 53).
- 2 Press <Ctrl><i> when you are prompted to enter the Intel RAID Option ROM utility.
- 3 Use the up- and down-arrow keys to highlight **Create RAID Volume**, and press <Enter>.
- 4 Enter a RAID volume name or accept the default, and press <Enter>.
- 5 Use the up- and down-arrow keys to select **RAID5(Parity)**, and press <Enter>.
- 6 Press the up- and down-arrow keys and spacebar to select the three or four drives you want to use to make up your volume, and then press <Enter>.
- 7 Select the desired capacity for the volume, and press <Enter>. The default value is the maximum available size.
- 8 Press <Enter> to create the volume.
- 9 Press <y> to confirm that you want to create the RAID volume.
- 10 Confirm that the correct volume configuration is displayed on the main Intel RAID Option ROM utility screen.
- 11 Use the up- and down-arrow keys to select **Exit**, and press <Enter>.
- 12 Install the operating system (see "Reinstalling Windows XP or Windows Vista" on page 149.)

Deleting a RAID Volume

- ➔ **NOTICE:** When you perform this operation, all data on the RAID drives will be lost.
 - ➔ **NOTICE:** If your computer currently boots to RAID and you delete the RAID volume in the Intel RAID Option ROM utility, your computer will become unbootable.
- 1 Press <Ctrl><i> when you are prompted to enter the Intel RAID Option ROM utility.
 - 2 Use the up- and down-arrow keys to highlight **Delete RAID Volume**, and press <Enter>.
 - 3 Use the up- and down-arrow keys to highlight the RAID volume you want to delete, and press <Delete>.
 - 4 Press <y> to confirm the deletion of the RAID volume.
 - 5 Press <Esc> to exit the Intel RAID Option ROM utility.

Setting Up Your Computer

Installing Your Computer in an Enclosure

Installing your computer in an enclosure can restrict the airflow and impact your computer's performance, possibly causing it to overheat. Follow the guidelines below when installing your computer in an enclosure:

- ➡ **NOTICE:** The operating temperature specifications indicated in this manual reflects the maximum ambient operating temperature. The room ambient temperature needs to be a consideration when installing your computer in an enclosure. For example, if the ambient room temperature is at 25°C (77°F), depending on your computer's specifications, you only have 5° to 10°C (9° to 18°F) temperature margin before you reach your computer's maximum operating temperature. For details about your computer's specifications, see "Specifications" on page 36.
- Leave a 10.2 cm (4 in) minimum clearance on all vented sides of the computer to permit the airflow required for proper ventilation.
- If your enclosure has doors, they need to be of a type that allows at least 30 percent airflow through the enclosure (front and back).

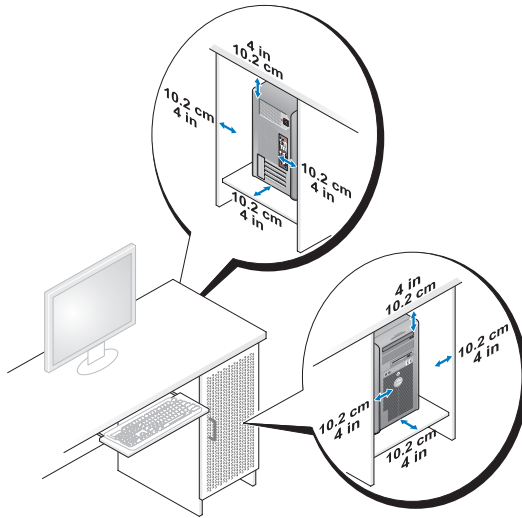

- If your computer is installed in a corner on a desk or under a desk, leave at least 5.1 cm (2 in) clearance from the back of the computer to the wall to permit the airflow required for proper ventilation.

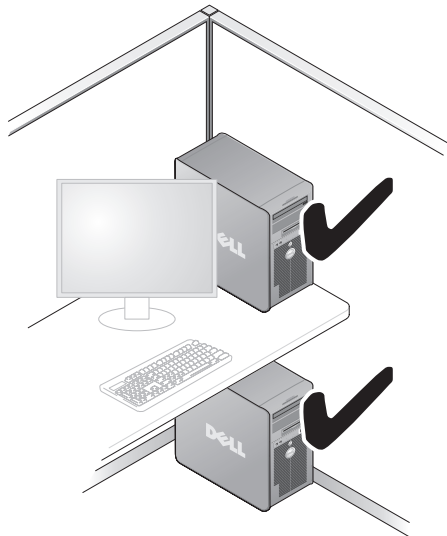

- ➔ NOTICE:** Do not install your computer in an enclosure that does not allow airflow. Restricting the airflow impacts your computer's performance, possibly causing it to overheat.

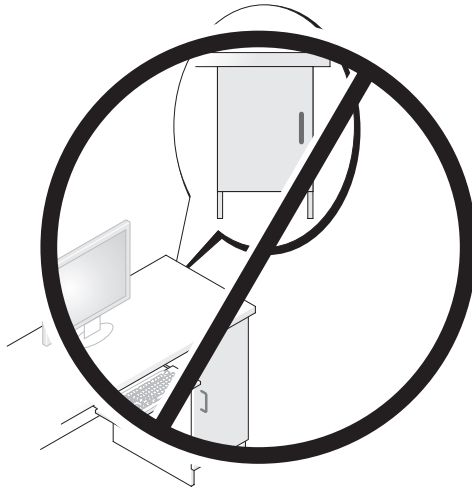

Connecting to the Internet

✎ NOTE: ISPs and ISP offerings vary by country.

For further information on troubleshooting e-mail and internet problems, see "E-Mail and Internet Problems" on page 109. To connect to the Internet, you need a modem or network connection and an Internet service provider (ISP). Your ISP will offer one or more of the following Internet connection options:

- DSL connections that provide high-speed Internet access through your existing telephone line or cellular telephone service. With a DSL connection, you can access the Internet and use your telephone on the same line simultaneously.
- Cable modem connections that provide high-speed Internet access through your local cable TV line.
- Satellite modem connections that provide high-speed Internet access through a satellite television system.

- Dial-up connections that provide Internet access through a telephone line. Dial-up connections are considerably slower than DSL and cable (or satellite) modem connections.
- Wireless LAN connections that provide Internet access using Bluetooth® wireless technology.

If you are using a dial-up connection, connect a telephone line to the modem connector on your computer and to the telephone wall jack before you set up your Internet connection. If you are using a DSL or cable/satellite modem connection, contact your ISP or cellular telephone service for setup instructions.

Setting Up Your Internet Connection

To set up an Internet connection with a provided ISP desktop shortcut:

- 1 Save and close any open files, and exit any open programs.
- 2 Double-click the ISP icon on the Microsoft® Windows® desktop.
- 3 Follow the instructions on the screen to complete the setup.

If you do not have an ISP icon on your desktop or if you want to set up an Internet connection with a different ISP, perform the steps in the following section that corresponds to the operating system your computer is using.



NOTE: If you cannot connect to the Internet but have successfully connected in the past, the ISP might have a service outage. Contact your ISP to check the service status, or try connecting again later.

Windows XP

- 1 Save and close any open files, and exit any open programs.
- 2 Click **Start** → **Internet Explorer**.
The **New Connection Wizard** appears.
- 3 Click **Connect to the Internet**.
- 4 In the next window, click the appropriate option:
 - If you do not have an ISP and want to select one, click **Choose from a list of Internet service providers (ISPs)**.
 - If you have already obtained setup information from your ISP but you did not receive a setup disc, click **Set up my connection manually**.

- If you have a disc, click **Use the CD I got from an ISP**.
- 5 Click **Next**.
If you selected **Set up my connection manually**, continue to step 6.
Otherwise, follow the instructions on the screen to complete the setup.



NOTE: If you do not know which type of connection to select, contact your ISP.

- 6 Click the appropriate option under **How do you want to connect to the Internet?**, and then click **Next**.
- 7 Use the setup information provided by your ISP to complete the setup.

Windows Vista™



NOTE: Have your ISP information ready. If you do not have an ISP, the **Connect to the Internet** wizard can help you get one.

- 1 Save and close any open files, and exit any open programs.
- 2 Click the Windows Vista Start button , and click **Control Panel**
- 3 Under **Network and Internet**, click **Connect to the Internet**.
The **Connect to the Internet** window appears.
- 4 Click either **Broadband (PPPoE)** or **Dial-up**, depending on how you want to connect:
 - Choose **Broadband** if you will use a DSL, satellite modem, cable TV modem, or Bluetooth wireless technology connection.
 - Chose **Dial-up** if you will use a dial-up modem or ISDN.



NOTE: If you do not know which type of connection to select, click **Help me choose** or contact your ISP.

- 5 Follow the instructions on the screen and use the setup information provided by your ISP to complete the setup.

Transferring Information to a New Computer

You can use your operating system "wizards" to help you transfer files and other data from one computer to another—for example, from an *old* computer to a *new* computer. For instructions, see the following section that corresponds to the operating system that your computer is running.

Microsoft® Windows® XP

The Microsoft Windows XP operating system provides the Files and Settings Transfer Wizard to move data from a source computer to a new computer.

You can transfer data, such as:

- E-mail messages
- Toolbar settings
- Window sizes
- Internet bookmarks

You can transfer the data to the new computer over a network or serial connection, or you can store it on removable media, such as a writable CD, for transfer to the new computer.



NOTE: You can transfer information from an old computer to a new computer by directly connecting a serial cable to the input/output (I/O) ports of the two computers. To transfer data over a serial connection, you must access the Network Connections utility from the Control Panel and perform additional configuration steps, such as setting up an advanced connection and designating the host computer and the guest computer.

For instructions on setting up a direct cable connection between two computers, see Microsoft Knowledge Base Article #305621, titled *How to Set Up a Direct Cable Connection Between Two Computers in Windows XP*. This information may not be available in certain countries.

For transferring information to a new computer, you must run the Files and Settings Transfer Wizard. You can use the optional *Operating System* disc for this process or you can create a wizard disk with the Files and Settings Transfer Wizard.

Running the Files and Settings Transfer Wizard With the Operating System Disc



NOTE: This procedure requires the *Operating System* disc. This disc is optional and may not be included with certain computers.

To prepare a new computer for the file transfer:

- 1 Open the Files and Settings Transfer Wizard: click **Start**→ **All Programs**→ **Accessories**→ **System Tools**→ **Files and Settings Transfer Wizard**.
- 2 When the Files and Settings Transfer Wizard welcome screen appears, click **Next**.

- 3 On the **Which computer is this?** screen, click **New Computer**→**Next**.
- 4 On the **Do you have a Windows XP CD?** screen, click **I will use the wizard from the Windows XP CD**→**Next**.
- 5 When the **Now go to your old computer** screen appears, go to your old or source computer. Do *not* click **Next** at this time.

To copy data from the old computer:

- 1 On the old computer, insert the *Windows XP Operating System* disc.
- 2 On the **Welcome to Microsoft Windows XP** screen, click **Perform additional tasks**.
- 3 Under **What do you want to do?**, click **Transfer files and settings**→**Next**.
- 4 On the **Which computer is this?** screen, click **Old Computer**→**Next**.
- 5 On the **Select a transfer method** screen, click the transfer method you prefer.
- 6 On the **What do you want to transfer?** screen, select the items you want to transfer and click **Next**.

After the information has been copied, the **Completing the Collection Phase** screen appears.

- 7 Click **Finish**.

To transfer data to the new computer:

- 1 On the **Now go to your old computer** screen on the new computer, click **Next**.
- 2 On the **Where are the files and settings?** screen, select the method you chose for transferring your settings and files and click **Next**.

The wizard reads the collected files and settings and applies them to your new computer.

When all of the settings and files have been applied, the **Finished** screen appears.

- 3 Click **Finished** and restart the new computer.

Running the Files and Settings Transfer Wizard Without the Operating System Disc

To run the Files and Settings Transfer Wizard without the *Operating System* disc, you must create a wizard disk that will allow you to create a backup image file to removable media.

To create a wizard disk, use your new computer with Windows XP and perform the following steps:

- 1 Open the Files and Settings Transfer Wizard: click **Start**→**All Programs**→**Accessories**→**System Tools**→**Files and Settings Transfer Wizard**.
- 2 When the **Files and Settings Transfer Wizard** welcome screen appears, click **Next**.
- 3 On the **Which computer is this?** screen, click **New Computer**→**Next**.
- 4 On the **Do you have a Windows XP CD?** screen, click **I want to create a Wizard Disk in the following drive**→**Next**.
- 5 Insert the removable media, such as a writable CD, and click **OK**.
- 6 When the disk creation completes and the **Now go to your old computer** message appears, *do not* click **Next**.
- 7 Go to the old computer.

To copy data from the old computer:

- 1 On the old computer, insert the wizard disk.
- 2 Click **Start**→**Run**.
- 3 In the **Open** field on the **Run** window, browse to the path for **fastwiz** (on the appropriate removable media) and click **OK**.
- 4 On the **Files and Settings Transfer Wizard** welcome screen, click **Next**.
- 5 On the **Which computer is this?** screen, click **Old Computer**→**Next**.
- 6 On the **Select a transfer method** screen, click the transfer method you prefer.
- 7 On the **What do you want to transfer?** screen, select the items you want to transfer and click **Next**.

After the information has been copied, the **Completing the Collection Phase** screen appears.

- 8 Click **Finish**.

To transfer data to the new computer:

- 1 On the **Now go to your old computer** screen on the new computer, click **Next**.
- 2 On the **Where are the files and settings?** screen, select the method you chose for transferring your settings and files and click **Next**. Follow the instructions on the screen.

The wizard reads the collected files and settings and applies them to your new computer.

When all of the settings and files have been applied, the **Finished** screen appears.

- 3 Click **Finished** and restart the new computer.



NOTE: For more information about this procedure, search support.dell.com for document #154781 (*What Are The Different Methods To Transfer Files From My Old Computer To My New Dell™ Computer Using the Microsoft® Windows® XP Operating System?*).



NOTE: Access to the Dell™ Knowledge Base document may not be available in certain countries.

Microsoft Windows Vista™

- 1 Click the Windows Vista Start button , and then click **Transfer files and settings** → **Start Windows Easy Transfer**.
- 2 In the User Account Control dialog box, click **Continue**.
- 3 Click **Start a new transfer** or **Continue a transfer in progress**.

Follow the instructions provided on the screen by the Windows Easy Transfer wizard.

Power Protection Devices

Several devices are available to protect against power fluctuations and failures:

- Surge protectors
- Line conditioners
- Uninterruptible power supplies (UPS)

Surge Protectors

Surge protectors and power strips equipped with surge protection help prevent damage to your computer from voltage spikes that can occur during electrical storms or after power interruptions. Some surge protector manufacturers include warranty coverage for certain types of damage. Carefully read the device warranty when choosing a surge protector. A device with a higher joule rating offers more protection. Compare joule ratings to determine the relative effectiveness of different devices.

- ➔ **NOTICE:** Most surge protectors do not protect against power fluctuations or power interruptions caused by nearby lightning strikes. When lightning occurs in your area, disconnect the telephone line from the telephone wall jack and disconnect your computer from the electrical outlet.

Many surge protectors have a telephone jack for modem protection. See the surge protector documentation for modem connection instructions.

- ➔ **NOTICE:** Not all surge protectors offer network adapter protection. Disconnect the network cable from the network wall jack during electrical storms.

Line Conditioners

- ➔ **NOTICE:** Line conditioners do not protect against power interruptions.

Line conditioners are designed to maintain AC voltage at a fairly constant level.

Uninterruptible Power Supplies

- ➔ **NOTICE:** Loss of power while data is being saved to the hard drive may result in data loss or file damage.

NOTE: To ensure maximum battery operating time, connect only your computer to a UPS. Connect other devices, such as a printer, to a separate power strip that provides surge protection.

A UPS protects against power fluctuations and interruptions. UPS devices contain a battery that provides temporary power to connected devices when AC power is interrupted. The battery charges while AC power is available. See the UPS manufacturer documentation for information on battery operating time and to ensure that the device is approved by Underwriters Laboratories (UL).

Securing Your Computer

Chassis Intrusion Detection



CAUTION: Before you begin any of the procedures in this section, follow the safety instructions in the *Product Information Guide*.



CAUTION: To guard against electrical shock, always unplug your computer from the electrical outlet before opening the cover.



NOTICE: To prevent static damage to components inside your computer, discharge static electricity from your body before you touch any of your computer's electronic components. You can do so by touching an unpainted metal surface on the computer.

Removing the Chassis Intrusion Switch

- 1 Follow the procedures in "Before You Begin" on page 151.
- 2 Remove the computer cover (see "Removing the Computer Cover" on page 153).
- 3 Disconnect the chassis intrusion switch cable from the system board.
Note the routing of the chassis intrusion switch cable as you remove it from the chassis. Chassis hooks may hold the cable in place inside the chassis.
- 4 Slide the chassis intrusion switch out of its slot, and remove the switch and its attached cable from the computer.

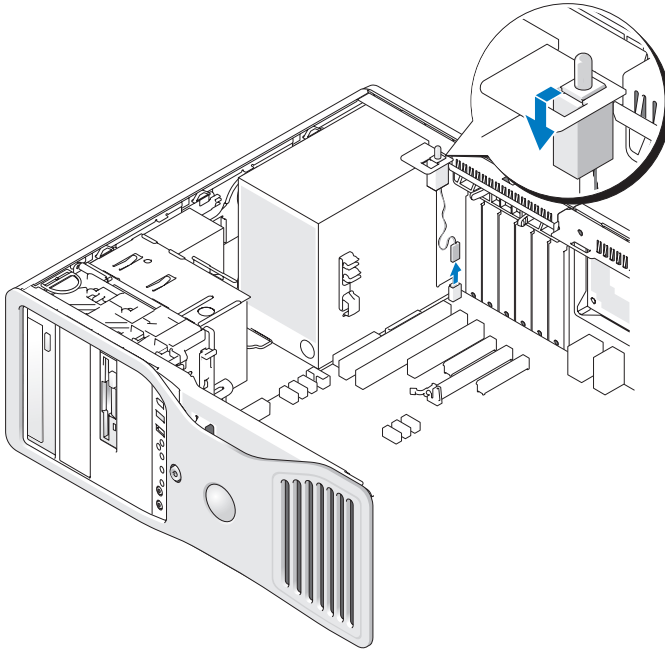

Replacing the Chassis Intrusion Switch

- 1 Gently slide the chassis intrusion switch into its slot and reconnect the cable to the system board.
 - 2 Replace the computer cover (see "Replacing the Computer Cover" on page 161).
- ➔ NOTICE:** To connect a network cable, first plug the cable into the network port or device and then plug it into the computer.
- 3 Connect your computer and devices to electrical outlets, and turn them on.

Resetting the Chassis Intrusion Detector

- 1 Turn on (or restart) your computer.
- 2 When the blue DELL™ logo appears, press <F2> immediately.

If you wait too long and the operating system logo appears, continue to wait until you see the Microsoft® Windows® desktop. Then shut down your computer (see "Turning Off Your Computer" on page 151) and try again.

- 3 Enter the system setup program (see "System Setup" on page 89).
- 4 Press the down-arrow key to move to the **Security** option.
- 5 Press <Enter> to access the menu.
- 6 Use the down-arrow key to select **Intrusion Alert**.
- 7 Use the left- and right-arrow keys to select **Reset**, and then choose **On**, **On-Silent**, or **Disabled**.



NOTE: The default setting is **On-Silent**.

- 8 Restart the computer and implement your changes.

Security Cable Lock

Use one of the following methods to secure your computer:

- Use a padlock alone or a padlock and looped security cable with the padlock ring.

A padlock alone prevents the computer from being opened.

A security cable looped around a stationary object is used in conjunction with a padlock to prevent unauthorized movement of the computer.

- Attach a commercially available antitheft device to the security cable slot on the back of the computer.



NOTE: Before you purchase an antitheft device, make sure that it works with the security cable slot on your computer.

Antitheft devices usually include a segment of metal-stranded cable with an attached locking device and key. The documentation that comes with the device contains instructions for installing it.

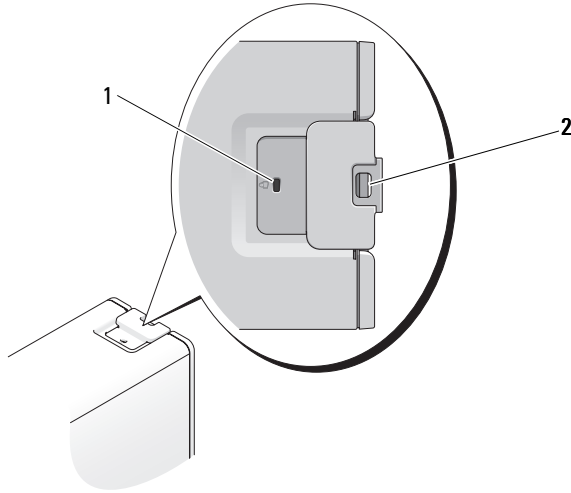

1 security cable slot

2 padlock ring

Passwords

About Passwords

 **NOTE:** Passwords are disabled when you receive your computer.

A primary (or system) password, an administrator password, and a hard drive password all prevent unauthorized access to your computer in different ways. The following table identifies types and features of passwords available on your computer.

Type of Password

Primary (or system)
Administrator

Features

- Protects the computer from unauthorized access
- Gives system administrators or service technicians access to computers for repair or reconfiguration
- Allows you to restrict access to system setup in the same way a primary password restricts access to the computer
- Can be used instead of the primary password
- Helps protect the data on your hard drive or external hard drive (if one is being used) from unauthorized access



NOTE: Some hard drives do not support hard drive passwords.



NOTICE: Passwords provide a high level of security for data in your computer or hard drive. However, they are not foolproof. If you require more security, obtain and use additional forms of protection, such as smart cards, data encryption programs, or PC Cards with encryption features.

When using passwords, observe the following guidelines:

- Choose passwords that you can remember, but not ones that are easy to guess. For example, do not use the names of family members or pets for passwords.
- It is recommended that you do not write down passwords. If you do write it down, however, ensure that the password is stored in a secure place.
- Do not share passwords with other people.
- Ensure that people are not watching you when you type your password(s).

If you forget any of your passwords, contact Dell (see "Contacting Dell" on page 295). For your protection, Dell technical support staff will ask you for proof of your identity to ensure that only an authorized person can use the computer.

Using a Primary (or System) Password



NOTICE: If you leave your computer running and unattended without having a system password assigned, or if you leave your computer unlocked so that someone can disable the password by changing a jumper setting, anyone can access the data stored on your hard drive.

Option Settings

You cannot change or enter a new system password if either of the following two options is displayed:

- **Set** — A system password is assigned.
- **Disabled** — The system password is disabled by a jumper setting on the system board.

You can only assign a system password when the following option is displayed:

- **Not Set** — No system password is assigned and the password jumper on the system board is in the enabled position (the default setting).

Assigning a System Password

To escape from the field without assigning a system password, press <Esc> at any time before you complete step 5.

- 1** Enter the system setup program (see "System Setup" on page 89) and verify whether an **Unlock Setup** field is present under **Security**.
- 2** If the **Unlock Setup** field is present:
 - a** Use the arrow keys to navigate to the **Unlock Setup** field.
 - b** Press <Enter> to access the field.
 - c** Type in the administrator password and press <Enter>.
- 3** Use the arrow keys to navigate to the **System Password** field, and then press <Enter>.
- 4** Type your new password into the **New Password** field.

You can use up to 15 characters. To erase a character when entering your password, press <Backspace> or the left-arrow key. The password is not case sensitive.

Certain key combinations are not valid. If you enter one of these combinations, the speaker emits a beep.

As you press each character key (or the spacebar for a blank space), a placeholder appears in the field.

- 5** Press <Enter>.

If the new system password is less than 15 characters, the whole field fills with placeholders.

- 6 To confirm your password, type it a second time in the **Confirm New Password** field and press <Enter>.
- 7 Press <Enter> at the prompt.
The system password setting changes to **Set**.
- 8 Exit the system setup program.
Password protection takes effect when you restart the computer.

Typing Your System Password

When you start or restart your computer, the following prompt appears on the screen:

```
Type the system password and press <Enter>.  
Enter password:
```

If you have assigned an administrator password, the computer accepts your administrator password as an alternate system password.

If you type a wrong or incomplete system password, the following message appears on the screen:

```
** Incorrect password. **
```

If you again type an incorrect or incomplete system password, the same message appears on the screen. The third and subsequent times you type an incorrect or incomplete system password, the computer displays the following message:

```
** Incorrect password. **  
Number of unsuccessful password attempts: 3  
System halted! Must power down.
```

Even after your computer is turned off and on, the previous message is displayed each time you type an incorrect or incomplete system password.



NOTE: You can use **Password Changes** in conjunction with **System Password** and **Admin Password** to further protect your computer from unauthorized changes.

Deleting or Changing an Existing System Password

To escape from the field without assigning a system password, press <Esc> at any time before you complete step 5.

- 1 Enter the system setup program (see "System Setup" on page 89) and verify whether an **Unlock Setup** field is present under **Security**.

- 2 If the **Unlock Setup** field is present:
 - a Use the arrow keys to navigate to the **Unlock Setup** field.
 - b Press <Enter> to access the field.
 - c Type in the administrator password and press <Enter>.
- 3 Use the arrow keys to navigate to the **System Password** field, and then press <Enter>.
- 4 Type your password into the **Old Password** field.
- 5 If you are changing an existing password, follow the instructions in "Assigning a System Password" on page 80, starting from step 4.
- 6 If you are deleting a password, press <Enter> in **New Password** field, leaving the field blank.
- 7 Press <Enter> a second time, in the **Confirm New Password** field, leaving the field blank.
- 8 Confirm that **Not Set** is displayed for the **System Password** setting.
If **Not Set** is displayed, the system password has been deleted. If **Not Set** is *not* displayed, then repeat step 3 through step 8.
- 9 Exit the system setup program.

Using an Administrator Password

Option Settings

You cannot change or enter a new administrator password if the following option is displayed:

- **Disabled** — The administrator password is disabled by a jumper setting on the system board.

You can only assign an administrator password when one of the following options is displayed:

- **Set** — An administrator password is assigned.
- **Not Set** — No administrator password is assigned and the password jumper on the system board is in the enabled position (the default setting).

Assigning an Administrator Password

The administrator password can be the same as the system password. To escape from the field without assigning a system password, press <Esc> at any time before you complete step 5.



NOTE: If the two passwords are different, the administrator password can be used as an alternate system password. However, the system password cannot be used in place of the administrator password.

- 1 Enter the system setup program (see "System Setup" on page 89) and verify whether an **Unlock Setup** field is present under **Security**.
- 2 If the **Unlock Setup** field is present:
 - a Use the arrow keys to navigate to the **Unlock Setup** field.
 - b Press <Enter> to access the field.
 - c Type in the administrator password and press <Enter>.
- 3 Use the arrow keys to navigate to the **Admin Password** field, and then press <Enter>.
- 4 Type your new password into the **New Password** field.

You can use up to 15 characters. To erase a character when entering your password, press <Backspace> or the left-arrow key. The password is not case sensitive.

Certain key combinations are not valid. If you enter one of these combinations, the speaker emits a beep.

As you press each character key (or the spacebar for a blank space), a placeholder appears in the field.
- 5 Press <Enter>.

If the new administrator password is less than 15 characters, the whole field fills with placeholders.
- 6 To confirm your password, type it a second time in the **Confirm New Password** field and press <Enter>.
- 7 Press <Enter> at the prompt.

The administrator password setting changes to **Set**.
- 8 Exit the system setup program.

A change to **Admin Password** becomes effective immediately (no need to restart the computer).

Operating Your Computer With an Administrator Password Enabled

When you enter the system setup program (see "System Setup" on page 89), the **Unlock Setup** option is displayed.

If you do not type the correct administrator password into the **Unlock Setup** field, the computer lets you view, but not modify, system setup options.



NOTE: You can use **Password Changes** in conjunction with **Admin Password** to protect the system password from unauthorized changes.

Deleting or Changing an Existing Administrator Password

To change an existing administrator password, you must know the administrator password. To escape from the field without assigning a system password, press <Esc> at any time before you complete step 5.

- 1 Enter the system setup program (see "System Setup" on page 89).
- 2 Use the arrow keys to navigate to the **Admin Password** field, and then press <Enter>.
- 3 Type your password into the **Old Password** field.
- 4 If you are changing an existing password, follow the instructions in "Assigning an Administrator Password" on page 83, starting from step 4.
- 5 If you are deleting a password, press <Enter> in **New Password** field, leaving the field blank.
- 6 Press <Enter> a second time, in the **Confirm New Password** field, leaving the field blank.
- 7 Confirm that **Not Set** is displayed for the **Admin Password** setting.
If **Not Set** is displayed, the administrator password has been deleted. If **Not Set** is *not* displayed, then repeat step 3 through step 8.
- 8 Exit system setup.

Disabling a Forgotten Password and Setting a New Password

To reset system and/or administrator passwords, see "Trusted Platform Module (TPM)" on page 85.

Trusted Platform Module (TPM)



NOTE: The TPM feature supports encryption only if the operating system supports TPM. For more information, see the TPM software documentation and the help files that came with the software.

TPM is a hardware-based security feature that can be used to create and manage computer-generated encryption keys. When combined with security software, the TPM enhances existing network and computer security by enabling features such as file protection capabilities and protected e-mail. The TPM feature is enabled through a system setup option.



NOTICE: To secure your TPM data and encryption keys, follow the backup procedures documented in the *Broadcom Secure Foundation Getting Started Guide*. In the event of these backups being incomplete, lost, or damaged, Dell will be unable to assist in the recovery of encrypted data.

Enabling the TPM Feature

1 Enable the TPM:

- a Restart the computer and press <F2> during the Power On Self Test to enter the system setup program.
- b Select **Security**→**TPM Security** and press <Enter>.
- c Under **TPM Security**, select **On** and press <Enter>.
- d Press <Esc> to exit the setup program.
- e If prompted, click **Save/Exit**.

2 Activate the TPM setup program:

- a Restart the computer and press <F2> during the Power On Self Test to enter the system setup program.
- b Select **Security**→**TPM Activation** and press <Enter>.
- c Under **TPM Activation**, select **Activate** and press <Enter>.



NOTE: You only need to activate the program once.

- d Once the process is complete, the computer either restarts automatically or prompts you to restart your computer.

Security Management Software

The security management software is designed to utilize four different features to help you secure your computer:

- Log-in management
- Pre-boot authentication (using a fingerprint reader, smart card, or password)
- Encryption
- Private information management

Activating the Security Management Software



NOTE: You must first enable the TPM in order for the security management software to have full functionality.

- 1 Enable the TPM feature (see "Enabling the TPM Feature" on page 85).
- 2 Load the security management software.

Using the Security Management Software

For information about how to use the software and the different security features, see the *Getting Started Guide* for the software:

Click **Start**→ **All Programs**→ **Wave EMBASSY Trust Suite**→ **Getting Started Guide**.

Computer Tracking Software

Computer tracking software may enable you to locate your computer if it is lost or stolen. The software is optional and may be purchased when you order your Dell™ computer, or you can contact your Dell sales representative for information about this security feature.



NOTE: Computer tracking software may not be available in certain countries.



NOTE: If you have computer tracking software and your computer is lost or stolen, you must contact the company that provides the tracking service to report the missing computer.

If Your Computer Is Lost or Stolen

- Call a law enforcement agency to report the lost or stolen computer. Include the Service Tag in your description of the computer. Ask that a case number be assigned and write down the number, along with the name, address, and phone number of the law enforcement agency. If possible, obtain the name of the investigating officer.



NOTE: If you know where the computer was lost or stolen, call a law enforcement agency in that area. If you do not know, call a law enforcement agency where you live.

- If the computer belongs to a company, notify the security office of the company.
- Contact Dell customer service to report the missing computer. Provide the computer Service Tag, the case number, and the name, address, and phone number of the law enforcement agency to which you reported the missing computer. If possible, give the name of the investigating officer.

The Dell customer service representative will log your report under the computer Service Tag and record the computer as missing or stolen. If someone calls Dell for technical assistance and gives your Service Tag, the computer is identified automatically as missing or stolen. The representative will attempt to get the phone number and address of the caller. Dell will then contact the law enforcement agency to which you reported the missing computer.

System Setup

Overview

Use System Setup as follows:

- To change the system configuration information after you add, change, or remove any hardware in your computer
- To set or change a user-selectable option such as the user password
- To read the current amount of memory or set the type of hard drive installed

Before you use System Setup, it is recommended that you write down the System Setup screen information for future reference.



NOTICE: Unless you are an expert computer user, do not change the settings for this program. Certain changes can make your computer work incorrectly.

Entering System Setup

- 1 Turn on (or restart) your computer.
- 2 When the blue DELL™ logo is displayed, you must watch for the F2 prompt to appear.
- 3 Once this F2 prompt appears, press <F2> immediately.



NOTE: The F2 prompt indicates that the keyboard has initialized. This prompt can appear very quickly, so you must watch for it to display, and then press <F2>. If you press <F2> before you are prompted, this keystroke will be lost.

- 4 If you wait too long and the operating system logo appears, continue to wait until you see the Microsoft® Windows® desktop. Then, shut down your computer and try again.

System Setup Options



NOTE: Depending on your computer and installed devices, the items listed in this section may not be present or may not appear exactly as listed.

System

System Info Displays the **Computer name**, **BIOS Version number**, **BIOS Date**, **Service Tag**, **Express Service Code**, and **Asset Tag**.

Processor Info Displays the following information for the processor installed in the system:

- **Processor Type**
 - **Processor Clock Speed**
 - **Processor Bus Speed**
 - **Processor L2 Cache Size**
 - **Processor ID number**
 - Family, Model, and Stepping
 - Microcode Version
 - whether the processor is **Hypertexting** or **Multi-core Capable**
 - if the processor supports **64-bit Technology**
-

Memory Info Displays the amount of **Installed Memory**, **Memory Speed**, **Memory Channel Mode**, and a description of the **Memory Technology**. This option also displays a table that describes the memory size, whether the memory module is **ECC** capable, single or dual rank, type, and organization.

PCI Info Displays the contents of each **PCI**, **PCI Express**, and **PCI-X** slot.

Date/Time Controls the system's internal calendar and clock.

Boot Sequence Determines the order in which the system searches for boot devices during system startup.

(**Diskette drive** default) **NOTE:** If you insert a boot device and restart the computer, this option appears in the system setup menu. To boot from a **USB** memory device, select the **USB** device and move it so it becomes the first device in the list.

Drives

Diskette Drive (Internal default)	Enables and disables the floppy drives and sets read permission for the internal floppy drive. Off disables all floppy drives. USB disables the internal diskette drive and enables a USB floppy drive, if the USB controller is enabled and a USB drive is connected. Internal enables the internal floppy drive. Read Only enables the internal drive controller and allows the internal floppy drive read-only permission. NOTE: Operating systems with USB support will recognize USB floppy drives regardless of this setting.
SATA 0 through 4 (On default)	Enables (On) or disables (Off) a SATA drive. Displays the Controller type (SATA), Port number the drive is using, Drive ID number, and Capacity. NOTE: SATA 4 can be enabled or disabled when SATA Operation is set to RAID Autodetect/AHCI . In other modes, this field might be non-functional. In this case, the text in the SATA 4 field reads as follows: This SATA port is disabled because the system has been configured for ATA mode.
SATA Operation (RAID Autodetect/ AHCI default)	Determines the integrated SATA controller's operating mode. RAID Autodetect/ AHCI – RAID if the drives are signed, otherwise AHCI. RAID Autodetect/ ATA – RAID if the drives are signed, otherwise ATA. RAID On – SATA is configured for RAID on every boot.
SMART Reporting (Off default)	Controls whether errors for integrated drives are reported during startup.

Onboard Devices

Integrated NIC (On default)	Enables or disables the integrated NIC controller. Settings are On, Off, On w/RPL, or On w/ PXE. When the On w/ PXE or the On w/RPL setting is active, if a boot routine is not available from the network server, the computer attempts to boot from the next device in the boot sequence list.
--	--

Integrated Audio (On default)	Enables (On) or disables (Off) the onboard audio controller. You can also select Auto to use the add-in Audio controller.
USB Controller (On default)	Enables or disables the internal USB controller. No Boot enables the controller but disables the ability to boot from a USB device. NOTE: Operating systems with USB support will recognize USB floppy drives regardless of the No Boot setting.
Front USB Ports (On default)	Enables or disables the front USB ports.
LPT Port Mode (PS/2 default)	Determines the mode of operation of the internal parallel port. Off disables the port. AT configures the port for AT compatibility. PS/2 configures the port for PS/2 compatibility. EPP configures the port for the EPP bidirectional protocol. ECP configures the port for the ECP bidirectional protocol. NOTE: If you set the LPT Port Mode to ECP , the LPT Port DMA appears in the option menu.
LPT Port Address	Determines the address that the built-in parallel port uses.
Serial Port #1 (Auto default)	Determines how the serial port operates. Off disables the port. Auto , the default setting, automatically configures a connector to a particular designation (COM1 or COM3).
Serial Port #2 (Auto default)	Determines how the serial port operates. Off disables the port. Auto , the default setting, automatically configures a connector to a particular designation (COM2 or COM4).
PS/2 Mouse Port (On default)	Enables or disables the integrated legacy PS/2-compatible mouse controller.

Video

Primary Video (PEG default)	This setting specifies which video controller is primary, PCI or PEG . PEG is the appropriate setting for a PCI Express graphics card or cards.
--	--

Performance

SpeedStep (Off default)	Enables Intel® SpeedStep® for all supported processors in the computer. This setting changes the processor power consumption and frequency. NOTE: This option may not be available on your computer.
VT for Direct I/O (Off default)	Specifies whether a virtual monitor (VMM) can use additional hardware capabilities provided by Intel Virtualization Technology for direct I/O.
Virtualization (Off default)	Specifies whether a virtual machine monitor (VMM) can utilize the additional hardware capabilities provided by Intel Virtualization technology.
Limit CPUID Value (Off default)	Limits the max value the processor standard CPUID function will support. Some operating systems won't complete installation when the max CPUID function supported is greater than 3.
HDD Acoustic Mode	Optimizes the hard drive's performance and acoustic levels. <ul style="list-style-type: none"> • Bypass - do nothing (needed for older drives) • Quiet - slower, but quieter • Suggested - allows the drive manufacturer to select mode • Performance - faster, but noisier
Snoop Filter	When enabled, the Snoop filter typically improves performance by reducing snoop traffic on the frontside bus in dual processor configurations.
ACL Prefetch	When enabled, the Adjacent Cache Line Prefetcher fetches both cache lines that comprise a cache line pair when it determines required data is not currently in its cache. When disabled, the processor will only fetch the cache line required by the processor.

HW Prefetch	Fetches an extra line of data into L2 from external memory.
FSB Optimization	Allows users to turn on/off optimization for high-bandwidth, frontside bus applications.

Security

Unlock Setup (Locked default)	When an administrator password is being used, allows the user access to modify system setup settings. Enter the administrator password at the prompt to unlock system setup. If the correct password is not entered here, the user can view but not modify system setup fields.
Admin Password (Not Set default)	Displays the current status of your system setup program's password security feature and allows you to verify and assign a new admin password.
System Password (Not Set default)	Displays the current status of the system's password security feature and allows a new system password to be assigned and verified.
SATA 0-n Password (Not Set default)	Displays the current status of the hard drive's password security feature and allows a new hard drive password to be assigned and verified.
Password Changes (Unlocked default)	Determines the interaction between the System password and the Admin password. Locked prevents a user without a valid Admin password from being able to modify the System password. Unlocked allows a user with a valid System password to modify the system password.
Chassis Intrusion (On-Silent default)	When enabled, this option alerts the user, during the next computer start-up, that the computer cover has been opened. The settings are On , On-Silent (default setting), and Off .
Intrusion Alert	Acknowledges and clears a chassis intrusion alert.

TPM Security (Off default)	Enables or disables the Trusted Platform Module security device.
Execute Disable (On default)	Enables or disables Execute Disable memory protection technology.
Computrace [®]	Activates or disables the BIOS module interface of the optional Computrace service from Absolute Software.

Power Management

AC Recovery (Off default)	Determines how the system responds when AC power is re-applied after a power loss. Off commands the system to stay off when the power is re-applied. You must press the front-panel power button before the system turns on. On commands the system to turn on when the power is re-applied. Last commands the system to return to the last power state the system was in just before it was turned off.
Auto Power On (Off default)	Sets the computer to automatically turn on. Off disables this feature. Everyday turns the computer on every day at the time set in Auto Power Time . Weekdays turns the computer on every day from Monday through Friday at the time set in Auto Power Time . NOTE: This feature does not work if you turn off your computer using a power strip or surge protector.
Auto Power Time	Sets time to automatically turn on the computer. Time is kept in the standard 12-hour format (<i>hours:minutes</i>). Change the startup time by pressing the right- or left-arrow key to increase or decrease the numbers, or type numbers in both the date and time fields.
Low Power Mode (Off default)	When Low Power Mode is selected, remote wakeup events will no longer power up the computer from Hibernate or Off via the onboard network controller.

Remote Wakeup (Off default)	<p>This option allows the system to power up when a Network Interface Controller (NIC) or Remote Wakeup-capable modem receives a wake up signal.</p> <p>On is the default setting. On w/ Boot to NIC will allow the computer to attempt to boot from a network prior to using the boot sequence.</p> <p>NOTE: Normally, the system can be powered up remotely from suspend mode, hibernate mode, or when powered off. When Low Power Mode (in the Power Management menu) is enabled, the system can only be powered up remotely from Suspend.</p>
Suspend Mode	<p>Sets the computer's suspend mode. The options are S1, a suspend state in which the computer is running in a low-power mode, and S3, a suspend state in which the power is reduced or turned off for many components, however, system memory remains active.</p>

Maintenance

Service Tag	Displays the service tag for your computer.
ASF Mode	<p>Controls ASF management.</p> <ul style="list-style-type: none"> • On = Full ASF 2.0 functionality (RMCP) • Alert Only - send ASF messages on event or error • Off - all ASF functionality disabled
SERR Message (On default)	Some graphics cards require that the SERR message be disabled.
Load Defaults	Restores system setup options to their factory defaults.
Event Log	Allows you to view the Event Log . Entries are marked R for Read and U for Unread . Mark All Entries Read puts an R to the left of all the entries. Clear Log clears the Event Log .

POST Behavior

Fast Boot (On default)	When enabled, this feature reduces computer startup time by bypassing some compatibility steps. Off does not skip any steps during computer startup. On starts the system more quickly.
Numlock Key (On default)	Determines the functionality of the numeric keys on the right side of your keyboard. Off commands the right keypad keys to function as arrows. On commands the right keypad keys to function as numbers.
OS Install (Off default)	Determines the maximum amount of system memory available to the operating system. When set to Off , all system memory is available to the operating system. When set to On , the maximum amount of memory available to the operating system is 256 MB. NOTE: Some operating systems will not complete installation with more than 2 GB of system memory.
POST Hotkeys	Determines whether the sign-on screen displays a message stating the keystroke sequence that is required to enter the Setup program or the Quickboot feature. Setup & Boot Menu displays both messages (F2=Setup and F12=Boot Menu). Setup displays the setup message only (F2=Setup). Boot Menu displays the Quickboot message only (F12=Boot Menu). None displays no message.
Keyboard Errors	When set to Report (enabled) and an error is detected during POST, the BIOS will display the error message and prompt you to press <F1> to continue or press <F2> to enter the system setup program. When set to Do Not Report (disabled) and an error is detected during POST, the BIOS will display the error message and continue booting the system.

Boot Menu

This feature allows you to change the boot sequence for devices.

Option Settings

- **Onboard or USB Floppy Drive** — The computer attempts to boot from the floppy drive. If the floppy disk in the drive is not bootable, if no floppy disk is in the drive, or if there is no floppy drive installed in the computer, the computer generates an error message.
- **Hard Drive** (listed by serial number when in AHCI mode) — The computer attempts to boot from the selected hard drive.



NOTE: In AHCI mode, all bootable hard drives are listed, not just the boot drive.

- **Onboard or USB CD-ROM Drive** — The computer attempts to boot from the CD-ROM drive. If no CD is in the drive, or if the CD has no operating system, the computer generates an error message.
- **USB Device** — Insert the memory device into a USB port and restart the computer. When **F12 = Boot Menu** appears in the upper-right corner of the screen, press <F12>. The BIOS detects the device and adds the USB option to the boot menu.



NOTE: To boot to a USB device, the device must be bootable. To make sure that your device is bootable, check the device documentation.

Selecting the Boot Device for the Current Boot

You can use this feature, for example, to restart your computer to a USB device such as a floppy drive, memory key, or CD-RW drive.



NOTE: If you are booting to a USB floppy drive, you must first set the Diskette Drive to **USB** in system setup (see "System Setup Options" on page 89).

- 1 If you are booting to a USB device, connect the USB device to a USB connector (see "About Your Computer" on page 19).
- 2 Turn on (or restart) your computer.
- 3 When **F2 = Setup**, **F12 = Boot Menu** appears in the upper-right corner of the screen, press <F12>.

If you wait too long and the operating system logo appears, continue to wait until you see the Microsoft Windows desktop. Then shut down your computer and try again.

A menu appears.

- 4 Use the up- and down-arrow keys to navigate to **Boot Device Menu**, then press <Enter> to select the option.
- 5 The **Boot Device Menu** appears, listing all available boot devices.
- 6 Use the up- and down-arrow keys to navigate to the device (that is to be used for the current boot only).
- 7 Press <Enter> to select the device.

For example, if you are booting to a USB memory key, highlight **USB Device** and press <Enter>.

 **NOTE:** To boot to a USB device, the device must be bootable. To make sure your device is bootable, check the device documentation.

Changing Boot Sequence for Future Boots

- 1 Enter the system setup program (see "System Setup" on page 89).
- 2 Use the arrow keys to highlight the **Boot Sequence** menu option and press <Enter> to access the menu.

 **NOTE:** Write down your current boot sequence in case you want to restore it.

- 3 Press the up- and down-arrow keys to move through the list of devices.
- 4 Press the spacebar to enable or disable a device.
- 5 Press <U> and <D> to move a selected device up or down the list.

Booting to a USB Device

 **NOTE:** To boot to a USB device, the device must be bootable. To ensure that your device is bootable, check the device documentation.

Memory Key

- 1 Insert the memory key into a USB port and restart the computer.
- 2 When **F12 = Boot Menu** appears in the upper-right corner of the screen, press <F12>.

The BIOS detects the device and adds the USB device option to the boot menu.

- 3 See "Selecting the Boot Device for the Current Boot" on page 98.

Floppy Drive

- 1** In system setup, set the **Diskette Drive** option to **USB**.
- 2** Save your changes and exit system setup.
- 3** Connect the USB floppy drive, insert bootable media, and re-boot the system.
- 4** See "Selecting the Boot Device for the Current Boot" on page 98.

Clearing Forgotten Passwords

CAUTION: Before you begin any of the procedures in this section, follow the safety instructions in the *Product Information Guide*.

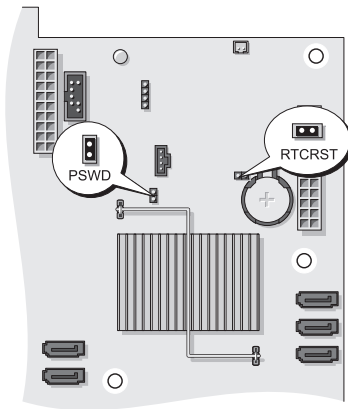

NOTICE: This process erases both the system and the administrator passwords.

- 1 Follow the procedures in "Before You Begin" on page 151.



Jumper	Setting	Description
PSWD		Password features are enabled (default setting).
		Password features are disabled.
RTCRST		The real-time clock has not been reset (default setting).
		The real-time clock is being reset.

jumpered
 unjumpered

- 2 Remove the computer cover (see "Removing the Computer Cover" on page 153).
 - 3 Locate the 2-pin password jumper (PSWD) on the system board, and remove the jumper plug; set the plug aside. For help locating the jumper, see "System Board Components" on page 28.
-  **NOTE:** When you receive your computer, the password jumper plug is on the password jumper.
- 4 Replace the computer cover (see "Replacing the Computer Cover" on page 161).
 - 5 Connect your computer and monitor to electrical outlets, and turn them on.
 - 6 After the Microsoft® Windows® desktop appears on your computer, shut down your computer (see "Turning Off Your Computer" on page 151).
 - 7 Turn off the monitor and disconnect it from the electrical outlet.
 - 8 Disconnect the computer power cable from the electrical outlet, and press the power button to ground the system board.
 - 9 Remove the computer cover (see "Removing the Computer Cover" on page 153).
 - 10 Locate the 2-pin password jumper on the system board and attach the jumper plug to its pins to re-enable the password feature. For more information see "System Board Components" on page 28.
 - 11 Replace the computer cover (see "Replacing the Computer Cover" on page 161).
-  **NOTICE:** To connect a network cable, first plug the cable into the network port or device and then plug it into the computer.
- 12 Connect your computer and devices to electrical outlets, and turn them on.
-  **NOTE:** This procedure enables the password feature. When you enter the system setup program (see "System Setup" on page 89), both system and administrator password options appear as **Not Set**—meaning that the password feature is enabled but no password is assigned.
- 13 Assign a new system and/or setup password. See "Passwords" on page 78.

Clearing CMOS Settings



CAUTION: Before you begin any of the procedures in this section, follow the safety instructions in the *Product Information Guide*.

- 1 Follow the procedures in "Before You Begin" on page 151.
 - 2 Remove the computer cover (see "Removing the Computer Cover" on page 153).
 - 3 Reset the current CMOS settings:
 - a Locate the password and CMOS jumpers (RTCRST) on the system board (see "System Board Components" on page 28).
 - b Remove the password jumper plug from its pins.
 - c Place the password jumper plug on the RTCRST pins and wait approximately 5 seconds.
 - d Remove the jumper plug from the RTCRST pins and place it back upon the password pins.
 - 4 Replace the computer cover (see "Replacing the Computer Cover" on page 161).
-  **NOTICE:** To connect a network cable, first plug the cable into the network port or device and then plug it into the computer.
- 5 Connect your computer and devices to electrical outlets, and turn them on.

Flashing the BIOS

The BIOS may require flashing when an update is available or when replacing the system board.

- 1 Turn on the computer.
- 2 Locate the BIOS update file for your computer at the Dell Support website at support.dell.com.
- 3 Click **Download Now** to download the file.
- 4 If the **Export Compliance Disclaimer** window appears, click **Yes, I Accept this Agreement**.
The **File Download** window appears.

- 5** Click **Save this program to disk**, and then click **OK**.
The **Save In** window appears.
- 6** Click the down arrow to view the **Save In** menu, select **Desktop**, and then click **Save**.
The file downloads to your desktop.
- 7** Click **Close** when the **Download Complete** window appears.
The file icon appears on your desktop and is titled the same as the downloaded BIOS update file.
- 8** Double-click the file icon on the desktop and follow the on-screen instructions.

Cleaning Your Computer

 **CAUTION:** Before you begin any of the procedures in this section, follow the safety instructions in the *Product Information Guide*.

Computer, Keyboard, and Monitor

 **CAUTION:** Before you clean your computer, disconnect the computer from the electrical outlet. Clean your computer with a soft cloth dampened with water. Do not use liquid or aerosol cleaners, which may contain flammable substances.

Use a can of compressed air to remove dust from between the keys on the keyboard.

Floppy Drive

 **NOTICE:** Do not attempt to clean drive heads with a swab. You might accidentally misalign the heads which prevents the drive from operating.

Clean your floppy drive using a commercially available cleaning kit. These kits contain pretreated floppy disks to remove contaminants that accumulate during normal operation.

CDs and DVDs

 **NOTICE:** Always use compressed air to clean the lens in the optical drive, and follow the instructions that come with the compressed-air product. Never touch the lens in the drive.

If you notice problems, such as skipping, with the playback quality of your CDs or DVDs, try cleaning the disks.

- 1 Hold the disk by its outer edge. You can also touch the inside edge of the center hole.

 **NOTICE:** To avoid damaging the surface, do not wipe in a circular motion around the disk.

- 2 With a soft, lint-free cloth, gently wipe the bottom of the disk (the unlabeled side) in a straight line from the center to the outer edge of the disk.

For stubborn dirt, try using water or a diluted solution of water and mild soap. You can also purchase commercial products that clean disks and provide some protection from dust, fingerprints, and scratches. Cleaning products for CDs are also safe to use on DVDs.

Troubleshooting

Solving Problems

Follow these tips when you troubleshoot your computer:

- If you added or removed a part before the problem started, review the installation procedures and ensure that the part is correctly installed.
- If a peripheral device does not work, ensure that the device is properly connected.
- If an error message appears on the screen, write down the exact message. This message may help support personnel diagnose and fix the problem(s).
- If an error message occurs in a program, see the program's documentation.



NOTE: The procedures in this document were written for the Windows default view, so they may not apply if you set your Dell™ computer to the Windows Classic view.

Battery Problems



CAUTION: There is a danger of a new battery exploding if it is incorrectly installed. Replace the battery only with the same or equivalent type recommended by the manufacturer. Discard used batteries according to the manufacturer's instructions.



CAUTION: Before you begin any of the procedures in this section, follow the safety instructions in the *Product Information Guide*.

REPLACE THE BATTERY — If you have to repeatedly reset time and date information after turning on the computer, or if an incorrect time or date displays during start-up, replace the battery. If the battery still does not work properly, contact Dell (see "Contacting Dell" on page 295).

Drive Problems



CAUTION: Before you begin any of the procedures in this section, follow the safety instructions in the *Product Information Guide*.

ENSURE THAT MICROSOFT® WINDOWS® RECOGNIZES THE DRIVE —

Windows XP:

- Click **Start** and click **My Computer**.

Windows Vista™:

- Click the Windows Vista Start button  and click **Computer**.

If the drive is not listed, perform a full scan with your antivirus software to check for and remove viruses. Viruses can sometimes prevent Windows from recognizing the drive.

TEST THE DRIVE —

- Insert another disc to eliminate the possibility that the original drive is defective.
- Insert a bootable floppy disk and restart the computer.

CLEAN THE DRIVE OR DISK — See "Cleaning Your Computer" on page 105.

CHECK THE CABLE CONNECTIONS

RUN THE HARDWARE TROUBLESHOOTER — See "Troubleshooting Software and Hardware Problems in the Microsoft® Windows® XP and Microsoft Windows Vista™ Operating Systems" on page 143.

RUN THE DELL DIAGNOSTICS — See "Dell Diagnostics" on page 136.

Optical drive problems



NOTE: High-speed optical drive vibration is normal and may cause noise, which does not indicate a defect in the drive or the media.



NOTE: Because of different regions worldwide and different disc formats, not all DVD titles work in all DVD drives.

ADJUST THE WINDOWS VOLUME CONTROL —

- Click the speaker icon in the lower-right corner of your screen.
- Ensure that the volume is turned up by clicking the sidebar and dragging it up.
- Ensure that the sound is not muted by clicking any boxes that are checked.

Problems writing to an optical drive

CLOSE OTHER PROGRAMS — The optical drive must receive a steady stream of data during the writing process. If the stream is interrupted, an error occurs. Try closing all programs before you write to the optical.

TURN OFF STANDBY MODE IN WINDOWS BEFORE WRITING TO A DISK — See "Power Management" on page 47 or search for the keyword *standby* in Windows Help and Support for information on power management modes.

Hard drive problems

RUN CHECK DISK —

Windows XP:

- 1 Click **Start** and click **My Computer**.
- 2 Right-click **Local Disk C:**.
- 3 Click **Properties**→**Tools**→**Check Now**.
- 4 Click **Scan for and attempt recovery of bad sectors and click Start**.

Windows Vista:

- 1 Click **Start**  and click **Computer**.
- 2 Right-click **Local Disk C:**.
- 3 Click **Properties**→**Tools**→**Check Now**.

The **User Account Control** window may appear. If you are an administrator on the computer, click **Continue**; otherwise, contact your administrator to continue the desired action.

- 4 Follow the instructions on the screen.

E-Mail and Internet Problems



CAUTION: Before you begin any of the procedures in this section, follow the safety instructions in the *Product Information Guide*.

CHECK THE MICROSOFT OUTLOOK® EXPRESS SECURITY SETTINGS — If you cannot open your e-mail attachments:

- 1 In Outlook Express, click **Tools**→**Options**→**Security**.
- 2 Click **Do not allow attachments** to remove the checkmark, as needed.

CHECK THE TELEPHONE LINE CONNECTION

CHECK THE TELEPHONE JACK

CONNECT THE MODEM DIRECTLY TO THE TELEPHONE WALL JACK

USE A DIFFERENT TELEPHONE LINE —

- Verify that the telephone line is connected to the jack on the modem (the jack has either a green label or a connector-shaped icon next to it).
- Ensure that you hear a click when you insert the telephone line connector into the modem.
- Disconnect the telephone line from the modem and connect it to a telephone, then listen for a dial tone.

- If you have other telephone devices sharing the line, such as an answering machine, fax machine, surge protector, or line splitter, bypass them and use the telephone to connect the modem directly to the telephone wall jack. If you are using a line that is 3 meters (10 feet) or more in length, try a shorter one.

RUN THE MODEM DIAGNOSTIC TOOL —

Windows XP:

- 1 Click **Start** → **All Programs** → **Modem Helper**.
- 2 Follow the instructions on the screen to identify and resolve modem problems. Modem Helper is not available on certain computers.

Windows Vista:

- 1 Click **Start**  → **All Programs** → **Modem Diagnostic Tool**.
- 2 Follow the instructions on the screen to identify and resolve modem problems. Modem diagnostics are not available on all computers.

VERIFY THAT THE MODEM IS COMMUNICATING WITH WINDOWS —

Windows XP:

- 1 Click **Start** → **Control Panel** → **Printers and Other Hardware** → **Phone and Modem Options** → **Modems**.
- 2 Click the COM port for your modem → **Properties** → **Diagnostics** → **Query Modem** to verify that the modem is communicating with Windows.
If all commands receive responses, the modem is operating properly.

Windows Vista:

- 1 Click **Start**  → **Control Panel** → **Hardware and Sound** → **Phone and Modem Options** → **Modems**.
- 2 Click the COM port for your modem → **Properties** → **Diagnostics** → **Query Modem** to verify that the modem is communicating with Windows.
If all commands receive responses, the modem is operating properly.

ENSURE THAT YOU ARE CONNECTED TO THE INTERNET — Ensure that you have subscribed to an Internet provider. With the Outlook Express e-mail program open, click **File**. If **Work Offline** has a checkmark next to it, click the checkmark to remove it and connect to the Internet. For help, contact your Internet service provider.

Error Messages



CAUTION: Before you begin any of the procedures in this section, follow the safety instructions in the *Product Information Guide*.

If the error message is not listed, see the documentation for the operating system or the program that was running when the message appeared.

A FILENAME CANNOT CONTAIN ANY OF THE FOLLOWING CHARACTERS: \ / : * ? " < > | — Do not use these characters in filenames.

A REQUIRED .DLL FILE WAS NOT FOUND — The program that you are trying to open is missing an essential file. To remove and then reinstall the program:

Windows XP:

- 1 Click **Start** → **Control Panel** → **Add or Remove Programs** → **Programs and Features**.
- 2 Select the program you want to remove.
- 3 Click **Uninstall**.
- 4 See the program documentation for installation instructions.

Windows Vista:

- 1 Click **Start**  → **Control Panel** → **Programs** → **Programs and Features**.
- 2 Select the program you want to remove.
- 3 Click **Uninstall**.
- 4 See the program documentation for installation instructions.

drive letter : \ IS NOT ACCESSIBLE. THE DEVICE IS NOT READY — The drive cannot read the disk. Insert a disk into the drive and try again.

INSERT BOOTABLE MEDIA — Insert a bootable floppy disk, CD, or DVD.

NON-SYSTEM DISK ERROR — Remove the floppy disk from the floppy drive and restart your computer.

NOT ENOUGH MEMORY OR RESOURCES. CLOSE SOME PROGRAMS AND TRY AGAIN — Close all windows and open the program that you want to use. In some cases, you may have to restart your computer to restore computer resources. If so, run the program that you want to use first.

OPERATING SYSTEM NOT FOUND — Contact Dell (see "Contacting Dell" on page 295).

IEEE 1394 Device Problems



CAUTION: Before you begin any of the procedures in this section, follow the safety instructions in the *Product Information Guide*.



NOTE: Your computer supports only IEEE 1394a standard.

ENSURE THAT THE CABLE FOR THE IEEE 1394 DEVICE IS PROPERLY INSERTED INTO THE DEVICE AND INTO THE CONNECTOR ON THE COMPUTER

ENSURE THAT THE IEEE 1394 DEVICE IS ENABLED IN SYSTEM SETUP — See "System Setup Options" on page 89.

ENSURE THAT THE IEEE 1394 DEVICE IS RECOGNIZED BY WINDOWS —

Windows XP:

- 1 Click **Start** and click **Control Panel**.
- 2 Under **Pick a Category**, click **Performance and Maintenance** → **System** → **System Properties** → **Hardware** → **Device Manager**.

Windows Vista:

- 1 Click **Start**  → **Control Panel** → **Hardware and Sound**.
- 2 Click **Device Manager**.

If your IEEE 1394 device is listed, Windows recognizes the device.

IF YOU HAVE PROBLEMS WITH A DELL IEEE 1394 DEVICE — Contact Dell (see "Contacting Dell" on page 295).

IF YOU HAVE PROBLEMS WITH AN IEEE 1394 DEVICE NOT PROVIDED BY DELL — Contact the IEEE 1394 device manufacturer.

Keyboard Problems



CAUTION: Before you begin any of the procedures in this section, follow the safety instructions in the *Product Information Guide*.

CHECK THE KEYBOARD CABLE —

- Ensure that the keyboard cable is firmly connected to the computer.
- Shut down the computer, reconnect the keyboard cable as shown on the setup diagram for your computer, and then restart the computer.
- Ensure that the cable is not damaged or frayed and check cable connectors for bent or broken pins. Straighten any bent pins.
- Remove any keyboard extension cables and connect the keyboard directly to the computer.

TEST THE KEYBOARD — Connect a properly working keyboard to the computer, then try using the keyboard.

RUN THE HARDWARE TROUBLESHOOTER — See "Troubleshooting Software and Hardware Problems in the Microsoft® Windows® XP and Microsoft Windows Vista™ Operating Systems" on page 143.

Lockups and Software Problems



CAUTION: Before you begin any of the procedures in this section, follow the safety instructions in the *Product Information Guide*.

The computer does not start up

CHECK THE DIAGNOSTIC LIGHTS — See "Diagnostic Lights" on page 121.

ENSURE THAT THE POWER CABLE IS FIRMLY CONNECTED TO THE COMPUTER AND TO THE ELECTRICAL OUTLET

The computer stops responding



NOTICE: You may lose data if you are unable to perform an operating system shutdown.

TURN THE COMPUTER OFF — If you are unable to get a response by pressing a key on your keyboard or moving your mouse, press and hold the power button for at least 8 to 10 seconds (until the computer turns off), and then restart your computer.

A program stops responding

END THE PROGRAM —

- 1 Press <Ctrl><Shift><Esc> simultaneously to access the Task Manager.
- 2 Click the **Applications** tab.
- 3 Click to select the program that is no longer responding.
- 4 Click **End Task**.

A program crashes repeatedly



NOTE: Most software includes installation instructions in its documentation or on a floppy disk, CD, or DVD.

CHECK THE SOFTWARE DOCUMENTATION — If necessary, uninstall and then reinstall the program.

A program is designed for an earlier Windows operating system

RUN THE PROGRAM COMPATIBILITY WIZARD —

Windows XP:

The Program Compatibility Wizard configures a program so that it runs in an environment similar to non-XP operating system environments.

- 1 Click **Start**→**All Programs**→**Accessories**→**Program Compatibility Wizard**→**Next**.
- 2 Follow the instructions on the screen.

Windows Vista:

The Program Compatibility Wizard configures a program so that it runs in an environment similar to non-Windows Vista operating system environments.

- 1 Click **Start**  → **Control Panel** → **Programs** → Use an older program with this version of Windows.
- 2 In the welcome screen, click **Next**.
- 3 Follow the instructions on the screen.

A solid blue screen appears

TURN THE COMPUTER OFF — If you are unable to get a response by pressing a key on your keyboard or moving your mouse, press and hold the power button for at least 8 to 10 seconds (until the computer turns off), and then restart your computer.

Other software problems

CHECK THE SOFTWARE DOCUMENTATION OR CONTACT THE SOFTWARE MANUFACTURER FOR TROUBLESHOOTING INFORMATION —

- Ensure that the program is compatible with the operating system installed on your computer.
- Ensure that your computer meets the minimum hardware requirements needed to run the software. See the software documentation for information.
- Ensure that the program is installed and configured properly.
- Verify that the device drivers do not conflict with the program.
- If necessary, uninstall and then reinstall the program.

BACK UP YOUR FILES IMMEDIATELY

USE A VIRUS-SCANNING PROGRAM TO CHECK THE HARD DRIVE, FLOPPY DISKS, CDs, OR DVDs

SAVE AND CLOSE ANY OPEN FILES OR PROGRAMS AND SHUT DOWN YOUR COMPUTER THROUGH THE START MENU

Memory Problems



CAUTION: Before you begin any of the procedures in this section, follow the safety instructions in the *Product Information Guide*.

IF YOU RECEIVE AN INSUFFICIENT MEMORY MESSAGE —

- Save and close any open files and exit any open programs you are not using to see if that resolves the problem.
- See the software documentation for minimum memory requirements. If necessary, install additional memory (see "Installing Memory" on page 190).

- Reseat the memory modules (see "Memory" on page 187) to ensure that your computer is successfully communicating with the memory.
- Run the Dell Diagnostics (see "Dell Diagnostics" on page 136).

IF YOU EXPERIENCE OTHER MEMORY PROBLEMS —

- Reseat the memory modules (see "Memory" on page 187) to ensure that your computer is successfully communicating with the memory.
- Ensure that you are following the memory installation guidelines (see "Installing Memory" on page 190).
- Ensure that the memory you are using is supported by your computer. For more information about the type of memory supported by your computer, see "Memory" on page 187.
- Run the Dell Diagnostics (see "Dell Diagnostics" on page 136).

Mouse Problems



CAUTION: Before you begin any of the procedures in this section, follow the safety instructions in the *Product Information Guide*.

CHECK THE MOUSE CABLE —

- Ensure that the cable is not damaged or frayed and check cable connectors for bent or broken pins. Straighten any bent pins.
- Remove any mouse extension cables, and connect the mouse directly to the computer.
- Verify that the mouse cable is connected as shown on the setup diagram for your computer.

RESTART THE COMPUTER —

- 1 Simultaneously press <Ctrl><Esc> to display the **Start** menu.
- 2 Press <u>, press the up- and down-arrow keys to highlight **Shut down or Turn Off**, and then press <Enter>.
- 3 After the computer turns off, reconnect the mouse cable as shown on the setup diagram.
- 4 Turn on the computer.

TEST THE MOUSE — Connect a properly working mouse to the computer, then try using the mouse.

CHECK THE MOUSE SETTINGS —

Windows XP:

- 1 Click **Start**→ **Control Panel**→ **Mouse**.
- 2 Adjust the settings as needed.

Windows Vista:

1 Click Start  → Control Panel → Hardware and Sound → Mouse.

2 Adjust the settings as needed.

REINSTALL THE MOUSE DRIVER — See "Drivers" on page 141.

RUN THE HARDWARE TROUBLESHOOTER — See "Troubleshooting Software and Hardware Problems in the Microsoft® Windows® XP and Microsoft Windows Vista™ Operating Systems" on page 143.

Network Problems



CAUTION: Before you begin any of the procedures in this section, follow the safety instructions in the *Product Information Guide*.

CHECK THE NETWORK CABLE CONNECTOR — Ensure that the network cable is firmly inserted into the network connector on the back of the computer and the network jack.

CHECK THE NETWORK LIGHTS ON THE BACK OF THE COMPUTER — If the link integrity light is off (see "Controls and Lights" on page 40), no network communication is occurring. Replace the network cable.

RESTART THE COMPUTER AND LOG ON TO THE NETWORK AGAIN

CHECK YOUR NETWORK SETTINGS — Contact your network administrator or the person who set up your network to verify that your network settings are correct and that the network is functioning.

RUN THE HARDWARE TROUBLESHOOTER — See "Troubleshooting Software and Hardware Problems in the Microsoft® Windows® XP and Microsoft Windows Vista™ Operating Systems" on page 143.

Power Problems



CAUTION: Before you begin any of the procedures in this section, follow the safety instructions in the *Product Information Guide*.

IF THE POWER LIGHT IS GREEN AND THE COMPUTER IS NOT RESPONDING — See "Diagnostic Lights" on page 121.

IF THE POWER LIGHT IS BLINKING GREEN — The computer is in standby mode. Press a key on the keyboard, move the mouse, or press the power button to resume normal operation.

IF THE POWER LIGHT IS OFF — The computer is either turned off or is not receiving power.

- Reseat the power cable in the power connector on the back of the computer and the electrical outlet.
- Bypass power strips, power extension cables, and other power protection devices to verify that the computer turns on properly.
- Ensure that any power strips being used are plugged into an electrical outlet and are turned on.
- Ensure that the electrical outlet is working by testing it with another device, such as a lamp.
- Ensure that the main power cable and front panel cable are securely connected to the system board (see "System Board Components" on page 28).

IF THE POWER LIGHT IS BLINKING AMBER — The computer is receiving electrical power, but an internal power problem may exist.

- Ensure that the voltage selection switch is set to match the AC power at your location (if applicable).
- Ensure that all components and cables are properly installed and securely connected to the system board (see "System Board Components" on page 28).

IF THE POWER LIGHT IS STEADY AMBER — A device may be malfunctioning or incorrectly installed.

- Ensure that the processor power cable is securely connected to the system board power connector (POWER2) (see "System Board Components" on page 28).
- Remove and then reinstall all memory modules (see "Memory" on page 187).

ELIMINATE INTERFERENCE — Some possible causes of interference are:

- Power, keyboard, and mouse extension cables
- Too many devices connected to the same power strip
- Multiple power strips connected to the same electrical outlet

Printer Problems



CAUTION: Before you begin any of the procedures in this section, follow the safety instructions in the *Product Information Guide*.



NOTE: If you need technical assistance for your printer, contact the printer's manufacturer.

CHECK THE PRINTER DOCUMENTATION — See the printer documentation for setup and troubleshooting information.

ENSURE THAT THE PRINTER IS TURNED ON

CHECK THE PRINTER CABLE CONNECTIONS —

- See the printer documentation for cable connection information.
- Ensure that the printer cables are securely connected to the printer and the computer.

TEST THE ELECTRICAL OUTLET — Ensure that the electrical outlet is working by testing it with another device, such as a lamp.

VERIFY THAT THE PRINTER IS RECOGNIZED BY WINDOWS —

Windows XP:

- 1 Click **Start** → **Control Panel** → **Printers and Other Hardware** → **View installed printers or fax printers**.
- 2 If the printer is listed, right-click the printer icon.
- 3 Click **Properties** → **Ports**. For a parallel printer, ensure that the **Print to the following port(s)**: setting is **LPT1 (Printer Port)**. For a USB printer, ensure that the **Print to the following port(s)**: setting is **USB**.

Windows Vista:

- 1 Click **Start**  → **Control Panel** → **Hardware and Sound** → **Printer**.
- 2 If the printer is listed, right-click the printer icon.
- 3 Click **Properties and click Ports**.
- 4 Adjust the settings, as needed.
- 5 Reinstall the printer driver.



NOTE: See the printer documentation for information on reinstalling the printer driver.

Scanner Problems



CAUTION: Before you begin any of the procedures in this section, follow the safety instructions in the *Product Information Guide*.



NOTE: If you need technical assistance for your scanner, contact the scanner's manufacturer.

CHECK THE SCANNER DOCUMENTATION — See the scanner documentation for setup and troubleshooting information.

UNLOCK THE SCANNER — Ensure that your scanner is unlocked (if the scanner has a locking tab or button).

RESTART THE COMPUTER AND TRY THE SCANNER AGAIN

CHECK THE CABLE CONNECTIONS —

- See the scanner documentation for information on cable connections.
- Ensure that the scanner cables are securely connected to the scanner and the computer.

VERIFY THAT THE SCANNER IS RECOGNIZED BY MICROSOFT WINDOWS —

Windows XP:

- 1 Click **Start** → **Control Panel** → **Printers and Other Hardware** → **Scanners and Cameras**.
- 2 If your scanner is listed, Windows recognizes the scanner.

Windows Vista:

- 1 Click **Start**  → **Control Panel** → **Hardware and Sound** → **Scanners and Cameras**.
- 2 If the scanner is listed, Windows recognizes the scanner.

REINSTALL THE SCANNER DRIVER — See the scanner documentation for instructions.

Sound Problems

 **CAUTION:** Before you begin any of the procedures in this section, follow the safety instructions in the *Product Information Guide*.

ADJUST THE WINDOWS VOLUME CONTROL — Click or double-click the speaker icon in the lower-right corner of your screen. Ensure that the volume is turned up and that the sound is not muted.

TEST THE ELECTRICAL OUTLET — Ensure that the electrical outlet is working by testing it with another device, such as a lamp.

ELIMINATE POSSIBLE INTERFERENCE — Turn off nearby fans, fluorescent lights, or halogen lamps to check for interference.

REINSTALL THE SOUND DRIVER — See "Drivers" on page 141.

RUN THE HARDWARE TROUBLESHOOTER — See "Troubleshooting Software and Hardware Problems in the Microsoft® Windows® XP and Microsoft Windows Vista™ Operating Systems" on page 143.





Troubleshooting Tools





Diagnostic Lights







 **CAUTION:** Before you begin any of the procedures in this section, follow the safety instructions in the *Product Information Guide*.

To help you troubleshoot a problem, your computer has four lights labeled "1," "2," "3," and "4" on the front. The lights can be "off" or green. When the computer starts normally, the lights flash. If the computer malfunctions, the pattern of the lights and also that of the power button help to identify the problem. These lights also indicate sleep states.

Diagnostic Light Codes Before POST

Diagnostic Lights	Power Light	Problem Description	Suggested Resolution
   	off	The computer is in a normal off condition or in Windows Hibernation mode.	<p>Press the power button to turn the computer on.</p> <p>If the computer does not turn on, ensure that the front-panel power light is on. If the power light is off, ensure that the computer is connected to a working electrical outlet and then press the power button.</p> <p>If the problem is still not resolved, contact Dell for technical assistance (see "Contacting Dell" on page 295).</p>

Diagnostic Lights	Power Light	Problem Description	Suggested Resolution
	blinking green	The computer is in a reduced power or "sleep" state.	<p>Use one of the appropriate methods to "wake up" the computer. See "Advanced Features" on page 45.</p> <p>If the problem is not resolved and you are trying to wake the computer with a USB mouse or keyboard, substitute the mouse or keyboard with a working PS/2 mouse or keyboard and then try to wake the computer.</p>
	green	None.	<p>The system hardware appears to be operating normally. Any issues seen may be related to the operating system or software.</p>
	amber	The BIOS is not executing.	<p>Ensure that the processor is seated correctly and restart the computer (see "Processor" on page 179).</p> <p>If the problem is still not resolved, contact Dell for technical assistance (see "Contacting Dell" on page 295).</p>
	blinking amber	A possible power supply or power cable failure has occurred.	<p>Perform the procedure in "Power Problems" on page 116.</p> <p>If the problem is still not resolved, contact Dell for technical assistance (see "Contacting Dell" on page 295).</p>



Diagnostic Lights	Power Light	Problem Description	Suggested Resolution
 (blinking)	amber	A possible system board failure has occurred.	Contact Dell for technical assistance (see "Contacting Dell" on page 295).
 (blinking)	amber	A possible system board failure has occurred.	Contact Dell for technical assistance (see "Contacting Dell" on page 295).
 (blinking)	amber	A possible system board failure has occurred.	Contact Dell for technical assistance (see "Contacting Dell" on page 295).
 (blinking)	amber	A possible system board failure has occurred.	Contact Dell for technical assistance (see "Contacting Dell" on page 295).
 (blinking)	amber	A processor mismatch exists.	See "Troubleshooting" on page 107 and then to "Processor" on page 179.
 (blinking)	amber	Power supply cables are not properly connected.	Verify that both power supply cables are plugged in to the motherboard.

Diagnostic Light Codes During POST



The power light displays a solid green for diagnostic light codes during POST.



Light Pattern	Problem Description	Suggested Resolution
	A possible processor failure has occurred.	Reinstall the processor (see "Processor" on page 179) and restart the computer.

Light Pattern	Problem Description	Suggested Resolution
	<p>A possible expansion card failure has occurred.</p>	<ol style="list-style-type: none"> <li data-bbox="689 240 958 411">1 Determine if a conflict exists by removing a card (not the graphics card) and then restarting the computer (see "Cards" on page 193). <li data-bbox="689 424 958 564">2 If the problem persists, reinstall the card that you removed, remove a different card, and then restart the computer. <li data-bbox="689 577 958 1011">3 Repeat this process for each card. If the computer starts normally, troubleshoot the last card removed from the computer for resource conflicts (see "Troubleshooting Software and Hardware Problems in the Microsoft® Windows® XP and Microsoft Windows Vista™ Operating Systems" on page 143). <li data-bbox="689 1024 958 1166">4 If the problem persists, contact Dell for technical assistance (see "Contacting Dell" on page 295).

Light Pattern	Problem Description	Suggested Resolution
	<p>A possible graphics card failure has occurred.</p>	<p>1 If the computer has a graphics card, remove the card, reinstall it, and then restart the computer (see "Cards" on page 193).</p> <p>2 If the problem still exists, install a graphics card that you know works and restart the computer.</p> <p>3 If the problem persists or the computer has integrated graphics, contact Dell for technical assistance (see "Contacting Dell" on page 295).</p>
	<p>A possible floppy or hard drive failure has occurred.</p>	<p>Reseat all power and data cables and restart the computer.</p>
	<p>A possible USB failure has occurred.</p>	<p>Reinstall all USB devices, check cable connections, and then restart the computer.</p>

Light Pattern	Problem Description	Suggested Resolution
	<p>No memory modules are detected.</p>	<ol style="list-style-type: none"> 1 Reseat the memory modules to ensure that your computer is successfully communicating with the memory (see "Memory" on page 187). 2 Restart the computer. 3 If the problem still exists, remove all the memory modules and install one memory module in memory module connector DIMM_1. 4 Restart the computer. A message appears stating that because your memory is not paired, the system will operate with reduced performance and reduced error-correction capability. 5 Press <F1> to boot to the operating system. 6 Run the Dell Diagnostics (see "Dell Diagnostics" on page 136). 7 If the memory module passes, shut down the computer (see "Turning Off Your Computer" on page 151), remove the memory module, and then repeat the process with the remaining memory modules until a memory error occurs during start-up or diagnostic testing.

Light Pattern	Problem Description	Suggested Resolution
		<p>If the first memory module tested is defective, repeat the process with the remaining modules to ensure that the remaining modules are not defective.</p> <p>8 When the defective memory module is identified, contact Dell for a replacement (see "Contacting Dell" on page 295).</p>
	<p>System board failure has occurred.</p>	<p>Contact Dell for technical assistance (see "Contacting Dell" on page 295).</p>
	<p>Memory modules are detected, but a memory configuration or compatibility error exists.</p>	<ul style="list-style-type: none"> • Ensure that no special memory module/memory connector placement requirements exist (see "Memory" on page 187). • Verify that the memory modules that you are installing are compatible with your computer (see "Memory" on page 187). • Reinstall the memory modules and restart the computer. • If the problem persists, contact Dell (see "Contacting Dell" on page 295).
	<p>Routine system activity preceding video initialization.</p>	<p>Watch your monitor for on-screen messages.</p>

Light Pattern	Problem Description	Suggested Resolution
	<p>A possible expansion card failure has occurred.</p>	<ol style="list-style-type: none"> 1 Determine if a conflict exists by removing a card (not a graphics card) and restarting the computer (see "Cards" on page 193). 2 If the problem persists, reinstall the card that you removed, remove a different card, and then restart the computer. 3 Repeat this process for each card. If the computer starts normally, troubleshoot the last card removed from the computer for resource conflicts (see "Troubleshooting Software and Hardware Problems in the Microsoft® Windows® XP and Microsoft Windows Vista™ Operating Systems" on page 143). 4 If the problem persists, contact Dell (see "Contacting Dell" on page 295).
	<p>Routine system activity preceding video initialization.</p>	<p>Watch your monitor for on-screen messages.</p>

Beep Codes

Your computer might emit a series of beeps during start-up if the monitor cannot display errors or problems. This series of beeps, called a beep code, identifies a problem. One possible beep code (code 1-3-1) consists of one beep, a burst of three beeps, and then one beep. This beep code tells you that the computer encountered a memory problem.

If your computer beeps during start-up:

- 1 Write down the beep code on the "Diagnostics Checklist" on page 294.
- 2 Run the Dell Diagnostics (see "Dell Diagnostics" on page 136) to identify a more serious cause.
- 3 Contact Dell for technical assistance (see "Contacting Dell" on page 295).

Code	Cause
1-1-2	Microprocessor register failure
1-1-3	NVRAM read/write failure
1-1-4	ROM BIOS checksum failure
1-2-1	Programmable interval timer failure
1-2-2	DMA initialization failure
1-2-3	DMA page register read/write failure
1-3	Video Memory Test failure
1-3-1 through 2-4-4	Memory not being properly identified or used
1-3-2	Memory problem
3-1-1	Slave DMA register failure
3-1-2	Master DMA register failure
3-1-3	Master interrupt mask register failure
3-1-4	Slave interrupt mask register failure
3-2-2	Interrupt vector loading failure
3-2-4	Keyboard Controller Test failure
3-3-1	NVRAM power loss

Code	Cause
3-3-2	Invalid NVRAM configuration
3-3-4	Video Memory Test failure
3-4-1	Screen initialization failure
3-4-2	Screen retrace failure
3-4-3	Search for video ROM failure
4-2-1	No timer tick
4-2-2	Shutdown failure
4-2-3	Gate A20 failure
4-2-4	Unexpected interrupt in protected mode
4-3-1	Memory failure above address 0FFFFh
4-3-3	Timer-chip counter 2 failure
4-3-4	Time-of-day clock stopped
4-4-1	Serial or parallel port test failure
4-4-2	Failure to decompress code to shadowed memory
4-4-3	Math-coprocessor test failure
4-4-4	Cache test failure

Error Messages

Fill out the "Diagnostics Checklist" on page 294 as you complete these checks.

 **CAUTION: Before you begin any of the procedures in this section, follow the safety instructions in the *Product Information Guide*.**

If the message is not listed, see the documentation for the operating system or the program that was running when the message appeared.

A FILENAME CANNOT CONTAIN ANY OF THE FOLLOWING CHARACTERS: \ / : * ? " < > | — Do not use these characters in filenames.

A REQUIRED .DLL FILE WAS NOT FOUND — The program that you are trying to open is missing an essential file. To remove and then reinstall the program:

- 1 Click the **Start** button, click **Control Panel**, and then click **Add or Remove Programs**.
- 2 Select the program you want to remove.
- 3 Click the **Change or Remove Program** icon.
- 4 See the program documentation for installation instructions.

ALERT! CPU FAN NOT DETECTED — Ensure that the cooling fan and airflow shroud are properly installed and working.

ALERT! PREVIOUS ATTEMPTS AT BOOTING THIS SYSTEM HAVE FAILED AT CHECKPOINT [*nnnn*]. FOR HELP IN RESOLVING THIS PROBLEM, PLEASE NOTE THIS CHECKPOINT AND CONTACT DELL TECHNICAL SUPPORT — Contact Dell and report the checkpoint code (*nnnn*) to the support technician (see "Contacting Dell" on page 295).

ALERT! PREVIOUS FAN FAILURES —

ALERT! PREVIOUS PROCESSOR THERMAL FAILURE —

ALERT! PREVIOUS SHUTDOWN DUE TO THERMAL EVENT —

Ensure that nothing is blocking the airflow vents and that all the fans are properly installed and operating correctly. Also, ensure that the processor heat-sink assembly is properly installed.

ALERT! PREVIOUS REBOOT WAS DUE TO VOLTAGE REGULATOR FAILURE — Contact Dell for assistance (see "Contacting Dell" on page 295).

ALERT! SYSTEM BATTERY VOLTAGE IS LOW — Replace the battery (see "Battery" on page 176).

ALERT! UNABLE TO INITIALIZE ALL INSTALLED MEMORY —

ALERT! UNCORRECTABLE MEMORY ERROR PREVIOUSLY DETECTED IN DIMM_X/Y —

See "Memory Problems" on page 114.

ATTACHMENT FAILED TO RESPOND — See "Drive Problems" on page 107.

BAD COMMAND OR FILE NAME — Ensure that you spelled the command correctly, put spaces in the proper place, and used the correct path name.

BAD ERROR-CORRECTION CODE (ECC) ON DISK READ — See "Drive Problems" on page 107.

CONTROLLER HAS FAILED — See "Drive Problems" on page 107.

DATA ERROR — See "Drive Problems" on page 107.

DECREASING AVAILABLE MEMORY — See "Lockups and Software Problems" on page 112.

DISKETTE DRIVE 0 SEEK FAILURE — See "Drive Problems" on page 107.

DISKETTE READ FAILURE — See "Drive Problems" on page 107.

DISKETTE SUBSYSTEM RESET FAILED — Run the Dell Diagnostics. See (see "Dell Diagnostics" on page 136).

DISKETTE WRITE PROTECTED — Slide the write-protect notch to the open position.

DRIVE NOT READY — Put a floppy disk in the drive.

GATE A20 FAILURE — See "Lockups and Software Problems" on page 112.

HARD-DISK CONFIGURATION ERROR —

HARD-DISK CONTROLLER FAILURE —

HARD-DISK DRIVE FAILURE —

HARD-DISK DRIVE FAILURE —

See "Drive Problems" on page 107.

INSERT BOOTABLE MEDIA — Insert a bootable floppy disk, CD, or other bootable media.

INVALID CONFIGURATION INFORMATION - PLEASE RUN SETUP PROGRAM — Enter the system setup program (see "System Setup" on page 89) and correct the computer configuration information.

KEYBOARD FAILURE — See "Keyboard Problems" on page 112.

MEMORY ADDRESS LINE FAILURE AT *address*, READ *value* EXPECTING *value* — See "Memory Problems" on page 114.

MEMORY ALLOCATION ERROR —

- 1 Turn off the computer, wait 30 seconds, and then restart the computer.
- 2 Try to run the program again.
- 3 If the error message appears again, see the software documentation for additional troubleshooting suggestions.

MEMORY DATA LINE FAILURE AT *address*, READ *value* EXPECTING *value* —

MEMORY DOUBLE WORD LOGIC FAILURE AT *address*, READ *value* EXPECTING *value* —

MEMORY ODD/EVEN LOGIC FAILURE AT *address*, READ *value* EXPECTING *value* —

MEMORY WRITE/READ FAILURE AT *address*, READ *value* EXPECTING *value* —

MEMORY SIZE IN CMOS INVALID —

See "Memory Problems" on page 114.

NO BOOT DEVICE AVAILABLE —

- If the floppy drive is your boot device, ensure that a bootable floppy disk is in the drive.
- If the hard drive is your boot device, ensure that the cables are connected and that the drive is installed properly and partitioned as a boot device.
- Enter system setup and ensure that the boot sequence information is correct (see "System Setup" on page 89).

NO BOOT SECTOR ON HARD-DISK DRIVE — Enter system setup and ensure that the computer configuration information for the hard drive is correct (see "System Setup" on page 89).

If the message continues to appear after you ensure that the information in system setup is correct, see your operating system documentation for reinstallation information.

NO TIMER TICK INTERRUPT — Run the Dell Diagnostics (see "Dell Diagnostics" on page 136).

NON-SYSTEM DISK OR DISK ERROR — Replace the floppy disk with one that has a bootable operating system or remove the floppy disk from drive A and restart the computer.

NOT A BOOT DISKETTE — Insert bootable media and restart your computer.

NOT ENOUGH MEMORY OR RESOURCES. CLOSE SOME PROGRAMS AND TRY AGAIN — Close all windows and open the program that you want to use. In some cases, you might have to restart your computer to restore computer resources. If so, run the program that you want to use first.

OPERATING SYSTEM NOT FOUND — Contact Dell (see "Contacting Dell" on page 295).

PLEASE CONNECT USB KEYBOARD/MOUSE TO USB PORTS ON THE BACK OF THE COMPUTER — Turn your computer off, connect the USB keyboard and/or mouse to the USB connectors on the back of the computer, and then restart your computer.

PLUG AND PLAY CONFIGURATION ERROR —

- 1 Turn your computer off, unplug it from the electrical outlet, and then remove all but one of the cards.
- 2 Plug in your computer and reboot it.
- 3 If the message reappears, the installed card might be malfunctioning. If the message does not reappear, turn off the computer and reinsert one of the other cards.
- 4 Repeat this process until you identify which card is malfunctioning.

READ FAULT —

REQUESTED SECTOR NOT FOUND —

RESET FAILED —

See "Drive Problems" on page 107.

SECTOR NOT FOUND —

- Run the Windows error-checking utility to check the file structure on the floppy disk or hard drive. See Windows Help for instructions.
- If a large number of sectors are defective, back up the data (if possible), and then reformat the floppy disk or hard drive.

SEEK ERROR — See "Drive Problems" on page 107.

SHUTDOWN FAILURE — Run the Dell Diagnostics. See (see "Dell Diagnostics" on page 136).

TIME-OF-DAY CLOCK STOPPED —

TIME-OF-DAY NOT SET —

Enter system setup and correct the date or time (see "System Setup" on page 89). If the problem persists, replace the battery (see "Battery" on page 176).

TIMER CHIP COUNTER 2 FAILED — Run the Dell Diagnostics. See (see "Dell Diagnostics" on page 136).

UNEXPECTED INTERRUPT IN PROTECTED MODE — Run the Dell Diagnostics (see "Dell Diagnostics" on page 136).

WARNING: DELL'S DISK MONITORING SYSTEM HAS DETECTED THAT DRIVE [0/1] ON THE IDE CONTROLLER IS OPERATING OUTSIDE OF NORMAL SPECIFICATIONS. IT IS ADVISABLE TO IMMEDIATELY BACK UP YOUR DATA AND REPLACE YOUR HARD DRIVE BY CALLING YOUR SUPPORT DESK OR DELL — If no replacement drive is immediately available and the drive is not the only bootable drive, enter system setup (see "System Setup" on page 89) and change the appropriate drive setting to **None**. Then remove the drive from the computer.

WRITE FAULT —

WRITE FAULT ON SELECTED DRIVE —

See "Drive Problems" on page 107.

<drive letter>\ is not accessible. The device is not ready — The floppy drive cannot read the disk. Insert a floppy disk into the drive and try again.

Dell Diagnostics



CAUTION: Before you begin any of the procedures in this section, follow the safety instructions in the *Product Information Guide*.

When to Use the Dell Diagnostics

If you experience a problem with your computer, perform the checks in "Lockups and Software Problems" on page 112 and run the Dell Diagnostics before you contact Dell for technical assistance.

It is recommended that you print these procedures before you begin.



NOTICE: The Dell Diagnostics works only on Dell™ computers.



NOTE: The *Drivers and Utilities* disc is optional and may not ship with your computer.

Enter system setup (see "System Setup" on page 89), review your computer's configuration information, and ensure that the device you want to test displays in system setup and is active.

Start the Dell Diagnostics from either your hard drive or from the *Drivers and Utilities* disc.

Starting the Dell Diagnostics From Your Hard Drive

- 1 Turn on (or restart) your computer.
- 2 When the DELL™ logo appears, press <F12> immediately.



NOTE: If you see a message stating that no diagnostics utility partition has been found, run the Dell Diagnostics from your *Drivers and Utilities* disc. See "Starting the Dell Diagnostics From the Drivers and Utilities Disc" on page 137.

If you wait too long and the operating system logo appears, continue to wait until you see the Microsoft® Windows® desktop. Then shut down your computer (see "Turning Off Your Computer" on page 151), and try again.

- 3 When the boot device list appears, highlight **Boot to Utility Partition** and press <Enter>.
- 4 When the Dell Diagnostics **Main Menu** appears (see "Dell Diagnostics Main Menu" on page 138), select the test that you want to run.

Starting the Dell Diagnostics From the Drivers and Utilities Disc

- 1 Insert the *Drivers and Utilities* disc.
- 2 Shut down and restart the computer.

When the DELL logo appears, press <F12> immediately.

If you wait too long and the Windows logo appears, continue to wait until you see the Windows desktop. Then shut down your computer and try again.



NOTE: The next steps change the boot sequence for one time only. On the next start-up, the computer boots according to the devices specified in the system setup program.

- 3 When the boot device list appears, highlight **Onboard or USB CD-ROM Drive** and press <Enter>.
- 4 Select the **Boot from CD-ROM** option from the menu that appears and press <Enter>.
- 5 Type 1 to start the menu and press <Enter> to proceed.

- 6 Select **Run the 32 Bit Dell Diagnostics** from the numbered list. If multiple versions are listed, select the version appropriate for your computer.
- 7 When the Dell Diagnostics **Main Menu** appears, select the test you want to run.

Dell Diagnostics Main Menu

- 1 After the Dell Diagnostics loads and the **Main Menu** screen appears, click the button for the option you want.

Option	Function
Express Test	Performs a quick test of devices. This test typically takes 10 to 20 minutes and requires no interaction on your part. Run Express Test first to increase the possibility of tracing the problem quickly.
Extended Test	Performs a thorough check of devices. This test typically takes 1 hour or more and requires you to answer questions periodically.
Custom Test	Tests a specific device. You can customize the tests you want to run.
Symptom Tree	Lists the most common symptoms encountered and allows you to select a test based on the symptom of the problem you are having.

- 2 If a problem is encountered during a test, a message appears with an error code and a description of the problem. Write down the error code and problem description and follow the instructions on the screen.

If you cannot resolve the error condition, contact Dell (see "Contacting Dell" on page 295).



NOTE: The Service Tag for your computer is located at the top of each test screen. If you contact Dell, technical support will ask for your Service Tag.

- 3 If you run a test from the **Custom Test** or **Symptom Tree** option, click the applicable tab described in the following table for more information.

Tab	Function
Results	Displays the results of the test and any error conditions encountered.
Errors	Displays error conditions encountered, error codes, and the problem description.
Help	Describes the test and may indicate requirements for running the test.
Configuration	<p>Displays your hardware configuration for the selected device.</p> <p>The Dell Diagnostics obtains configuration information for all devices from system setup, memory, and various internal tests, and it displays the information in the device list in the left pane of the screen. The device list may not display the names of all the components installed on your computer or all devices attached to your computer.</p>
Parameters	Allows you to customize the test by changing the test settings.

- 4** When the tests are completed, if you are running the Dell Diagnostics from the *Drivers and Utilities* disc, remove the disc.
- 5** Close the test screen to return to the **Main Menu** screen. To exit the Dell Diagnostics and restart the computer, close the **Main Menu** screen.

Reinstalling Software

Drivers

What Is a Driver?

A driver is a program that controls a device such as a printer, mouse, or keyboard. All devices require a driver program.

A driver acts like a translator between the device and any other programs that use the device. Each device has its own set of specialized commands that only its driver recognizes.

Dell ships your computer to you with required drivers already installed—no further installation or configuration is needed.

 **NOTICE:** The *Drivers and Utilities* disc may contain drivers for operating systems that are not on your computer. Ensure that you are installing software appropriate for your operating system.

Many drivers, such as the keyboard driver, come with your Microsoft Windows operating system. You may need to install drivers if you:

- Upgrade your operating system.
- Reinstall your operating system.
- Connect or install a new device.

Identifying Drivers

If you experience a problem with any device, identify whether the driver is the source of your problem and, if necessary, update the driver.

Microsoft® Windows® XP

- 1 Click Start→Control Panel.

- 2 Under **Pick a Category**, click **Performance and Maintenance**, and click **System**.
- 3 In the **System Properties** window, click the **Hardware** tab, and click **Device Manager**.

Microsoft Windows Vista™

- 1 Click the Windows Vista start button , and right-click **Computer**.
- 2 Click **Properties**→ **Device Manager**.



NOTE: The **User Account Control** window may appear. If you are an administrator on the computer, click **Continue**; otherwise, contact your administrator to continue.

Scroll down the list to see if any device has an exclamation point (a yellow circle with a [!]) on the device icon.

If an exclamation point is next to the device name, you may need to reinstall the driver or install a new driver (see "Reinstalling Drivers and Utilities" on page 142).

Reinstalling Drivers and Utilities



NOTICE: The Dell Support website at support.dell.com and your *Drivers and Utilities* disc provide approved drivers for Dell™ computers. If you install drivers obtained from other sources, your computer might not work correctly.

Using Windows Device Driver Rollback

If a problem occurs on your computer after you install or update a driver, use Windows Device Driver Rollback to replace the driver with the previously installed version.

Windows XP:

- 1 Click **Start**→ **My Computer**→ **Properties**→ **Hardware**→ **Device Manager**.
- 2 Right-click the device for which the new driver was installed and click **Properties**.
- 3 Click the **Drivers** tab→ **Roll Back Driver**.

Windows Vista:

- 1 Click the Windows Vista start button , and right-click **Computer**.
- 2 Click **Properties**→ **Device Manager**.



NOTE: The **User Account Control** window may appear. If you are an administrator on the computer, click **Continue**; otherwise, contact your administrator to enter the Device Manager.

- 3 Right-click the device for which the new driver was installed and click **Properties**.
- 4 Click the **Drivers** tab→ **Roll Back Driver**.

If Device Driver Rollback does not resolve the problem, then use System Restore (see "Restoring Your Operating System" on page 144) to return your computer to the operating state that existed before you installed the new driver.

Troubleshooting Software and Hardware Problems in the Microsoft® Windows® XP and Microsoft Windows Vista™ Operating Systems

If a device is either not detected during the operating system setup or is detected but incorrectly configured, you can use the Hardware Troubleshooter to resolve the incompatibility.

To start the Hardware Troubleshooter:

Windows XP:

- 1 Click **Start**→ **Help and Support**.
- 2 Type `hardware troubleshooter` in the search field and press <Enter> to start the search.
- 3 In the **Fix a Problem** section, click **Hardware Troubleshooter**.
- 4 In the **Hardware Troubleshooter** list, select the option that best describes the problem and click **Next** to follow the remaining troubleshooting steps.

Windows Vista:

- 1 Click the Windows Vista start button , and click **Help and Support**.
- 2 Type `hardware troubleshooter` in the search field and press <Enter> to start the search.
- 3 In the search results, select the option that best describes the problem and follow the remaining troubleshooting steps.

Restoring Your Operating System

You can restore your operating system in the following ways:

- System Restore returns your computer to an earlier operating state without affecting data files. Use System Restore as the first solution for restoring your operating system and preserving data files.
- Dell PC Restore by Symantec (available in Windows XP) and Dell Factory Image Restore (available in Windows Vista) returns your hard drive to the operating state it was in when you purchased the computer. Both permanently delete all data on the hard drive and remove any programs installed after you received the computer. Use Dell PC Restore or Dell Factory Image Restore only if System Restore did not resolve your operating system problem.
- If you received an *Operating System* disc with your computer, you can use it to restore your operating system. However, using the *Operating System* disc also deletes all data on the hard drive. Use the disc *only* if System Restore did not resolve your operating system problem.

Using Microsoft Windows System Restore

The Windows operating systems provide a System Restore option which allows you to return your computer to an earlier operating state (without affecting data files) if changes to the hardware, software, or other system settings have left the computer in an undesirable operating state. Any changes that System Restore makes to your computer are completely reversible.



NOTICE: Make regular backups of your data files. System Restore does not monitor your data files or recover them.



NOTE: The procedures in this document were written for the Windows default view, so they may not apply if you set your Dell™ computer to the Windows Classic view.

Starting System Restore



Windows XP:



NOTICE: Before you restore the computer to an earlier operating state, save and close any open files and exit any open programs. Do not alter, open, or delete any files or programs until the system restoration is complete.

- 1 Click **Start**→ **All Programs**→ **Accessories**→ **System Tools**→ **System Restore**.
- 2 Click either **Restore my computer to an earlier time** or **Create a restore point**.
- 3 Click **Next** and follow the remaining on-screen prompts.

Windows Vista:

- 1 Click **Start** .
- 2 In the Start Search box, type **System Restore** and press <Enter>.
 **NOTE:** The **User Account Control** window may appear. If you are an administrator on the computer, click **Continue**; otherwise, contact your administrator to continue the desired action.
- 3 Click **Next** and follow the remaining prompts on the screen.

In the event that System Restore did not resolve the issue, you may undo the last system restore.

Undoing the Last System Restore

-  **NOTICE:** Before you undo the last system restore, save and close all open files and exit any open programs. Do not alter, open, or delete any files or programs until the system restoration is complete.

Windows XP:

- 1 Click **Start**→ **All Programs**→ **Accessories**→ **System Tools**→ **System Restore**.
- 2 Click **Undo my last restoration** and click **Next**.

Windows Vista:

- 1 Click **Start** .
- 2 In the Start Search box, type **System Restore** and press <Enter>.
- 3 Click **Undo my last restoration** and click **Next**.

Enabling System Restore

-  **NOTE:** Windows Vista does not disable System Restore; regardless of low disk space. Therefore, the steps below apply only to Windows XP.

If you reinstall Windows XP with less than 200 MB of free hard-disk space available, System Restore is automatically disabled.

To see if System Restore is enabled:

- 1 Click **Start**→ **Control Panel**→ **Performance and Maintenance**→ **System**.
- 2 Click the **System Restore** tab and ensure that **Turn off System Restore** is unchecked.

Using Dell™ PC Restore and Dell Factory Image Restore



NOTICE: Using Dell PC Restore or Dell Factory Image Restore permanently deletes all data on the hard drive and removes any programs or drivers installed after you received your computer. If possible, back up the data before using these options. Use PC Restore or Dell Factory Image Restore only if System Restore did not resolve your operating system problem.



NOTE: Dell PC Restore by Symantec and Dell Factory Image Restore may not be available in certain countries or on certain computers.

Use Dell PC Restore (Windows XP) or Dell Factory Image Restore (Windows Vista) only as the last method to restore your operating system. These options restore your hard drive to the operating state it was in when you purchased the computer. Any programs or files added since you received your computer—including data files—are permanently deleted from the hard drive. Data files include documents, spreadsheets, e-mail messages, digital photos, music files, and so on. If possible, back up all data before using PC Restore or Factory Image Restore.

Windows XP: Dell PC Restore

Using PC Restore:

- 1 Turn on the computer.

During the boot process, a blue bar with **www.dell.com** appears at the top of the screen.

- 2 Immediately upon seeing the blue bar, press <Ctrl><F11>.

If you do not press <Ctrl><F11> in time, let the computer finish starting, and then restart the computer again.



NOTICE: If you do not want to proceed with PC Restore, click **Reboot**.

- 3 Click **Restore** and click **Confirm**.

The restore process takes approximately 6 to 10 minutes to complete.

- 4 When prompted, click **Finish** to reboot the computer.

 **NOTE:** Do not manually shut down the computer. Click **Finish** and let the computer completely reboot.

- 5 When prompted, click **Yes**.

The computer restarts. Because the computer is restored to its original operating state, the screens that appear, such as the End User License Agreement, are the same ones that appeared the first time the computer was turned on.

- 6 Click **Next**.

The **System Restore** screen appears and the computer restarts.

- 7 After the computer restarts, click **OK**.

Removing PC Restore:

 **NOTE:** Removing Dell PC Restore from the hard drive permanently deletes the PC Restore utility from your computer. After you have removed Dell PC Restore, you will not be able to use it to restore your computer operating system.

Dell PC Restore enables you to restore your hard drive to the operating state it was in when you purchased your computer. It is recommended that you *do not* remove PC Restore from your computer, even to gain additional hard-drive space. If you remove PC Restore from the hard drive, you cannot ever recall it, and you will never be able to use PC Restore to return your computer operating system to its original state.

- 1 Log on to the computer as a local administrator.
- 2 In Microsoft Windows Explorer, go to `c:\dell\utilities\DSR`.
- 3 Double-click the filename `DSRIRRemv2.exe`.

 **NOTE:** If you do not log on as a local administrator, a message appears stating that you that you must log on as administrator. Click **Quit**, and then log on as a local administrator.

 **NOTE:** If the partition for PC Restore does not exist on your computer hard drive, a message appears stating that the partition was not found. Click **Quit**; there is no partition to delete.

- 4 Click **OK** to remove the PC Restore partition on the hard drive.
- 5 Click **Yes** when a confirmation message appears.

The PC Restore partition is deleted and the newly available disk space is added to the free space allocation on the hard drive.

- 6 Right-click **Local Disk (C)** in Windows Explorer, click **Properties**, and verify that the additional disk space is available as indicated by the increased value for **Free Space**.
- 7 Click **Finish** to close the **PC Restore Removal** window and restart the computer.

Windows Vista: Dell Factory Image Restore

- 1 Turn on the computer. When the Dell logo appears, press <F8> several times to access the Vista Advanced Boot Options window.
- 2 Select **Repair Your Computer**.
The System Recovery Options window appears.
- 3 Select a keyboard layout and click **Next**.
- 4 To access the recovery options, log on as a local user. To access the command prompt, type `administrator` in the User name field, then click **OK**.
- 5 Click **Dell Factory Image Restore**.



NOTE: Depending upon your configuration, you may need to select **Dell Factory Tools**, then **Dell Factory Image Restore**.

The Dell Factory Image Restore welcome screen appears.

- 6 Click **Next**.

The Confirm Data Deletion screen appears.



NOTICE: If you do not want to proceed with Factory Image Restore, click **Cancel**.

- 7 Click the checkbox to confirm that you want to continue reformatting the hard drive and restoring the system software to the factory condition, then click **Next**.

The restore process begins and may take five or more minutes to complete. A message appears when the operating system and factory-installed applications have been restored to factory condition.

- 8 Click **Finish** to reboot the system.

Using the Operating System Disc

Before you Begin

If you are considering reinstalling the Windows operating system to correct a problem with a newly installed driver, first try using Windows Device Driver Rollback. See "Using Windows Device Driver Rollback" on page 142. If Device Driver Rollback does not resolve the problem, then use System Restore to return your operating system to the operating state it was in before you installed the new device driver. See "Using Microsoft Windows System Restore" on page 144.



NOTICE: Before performing the installation, back up all data files on your primary hard drive. For conventional hard drive configurations, the primary hard drive is the first drive detected by the computer.

To reinstall Windows, you need the following items:

- Dell™ *Operating System* disc
- Dell *Drivers and Utilities* disc



NOTE: The Dell *Drivers and Utilities* disc contains drivers that were installed during the assembly of the computer. Use the Dell *Drivers and Utilities* disc to load any required drivers. Depending on the region from which you ordered your computer, or whether you requested the disc, the Dell *Drivers and Utilities* disc and *Operating System* disc may not ship with your computer.

Reinstalling Windows XP or Windows Vista

The reinstallation process can take 1 to 2 hours to complete. After you reinstall the operating system, you must also reinstall the device drivers, virus protection program, and other software.



NOTICE: The *Operating System* disc provides options for reinstalling Windows XP. The options can overwrite files and possibly affect programs that are installed on your hard drive. Therefore, do not reinstall Windows XP unless a Dell technical support representative instructs you to do so.

- 1 Save and close any open files and exit any open programs.
- 2 Insert the *Operating System* disc.
- 3 Click **Exit** if the `Install Windows` message appears.
- 4 Restart the computer.

When the DELL logo appears, press <F12> immediately.

 **NOTE:** If you wait too long and the operating system logo appears, continue to wait until you see the Microsoft® Windows® desktop; then, shut down your computer and try again.

 **NOTE:** The next steps change the boot sequence for one time only. On the next start-up, the computer boots according to the devices specified in the system setup program.

- 5 When the boot device list appears, highlight **CD/DVD/CD-RW Drive** and press <Enter>.
- 6 Press any key to **Boot from CD-ROM**.
- 7 Follow the instructions on the screen to complete the installation.

Adding and Replacing Parts

Before You Begin

This chapter provides procedures for removing and installing the components in your computer. Unless otherwise noted, each procedure assumes that the following conditions exist:

- You have performed the steps in "Turning Off Your Computer" on page 151 and "Before Working Inside Your Computer" on page 152.
- You have read the safety information in the Dell™ *Product Information Guide*.
- A component can be replaced or—if purchased separately—installed by performing the removal procedure in reverse order.

Recommended Tools

The procedures in this document may require the following tools:

- Small flat-blade screwdriver
- Small Phillips screwdriver
- Small plastic scribe

Turning Off Your Computer



NOTICE: To avoid losing data, save and close all open files and exit all open programs before you turn off your computer.

- 1 Shut down the operating system:
 - a Save and close all open files and exit all open programs.
 - b *In the Microsoft® Windows® XP operating system, click Start→ Shut Down→ Shut down.*

In the Microsoft Windows Vista™ operating system, click the Windows Vista Start button , click the arrow in the lower-right corner of the Start menu as shown below, and then click **Shut Down**.



The computer turns off after the operating system shutdown process is complete.

- 2 Ensure that the computer and all attached devices are turned off. If your computer and attached devices did not automatically turn off when you shut down your operating system, press and hold the power button for about 4 seconds to turn them off.

Before Working Inside Your Computer

Use the following safety guidelines to help protect your computer from potential damage and to help to ensure your own personal safety.



CAUTION: Before you begin any of the procedures in this section, follow the safety instructions in the *Product Information Guide*.



CAUTION: Use proper weight-lifting precautions when picking up the computer.



NOTICE: Handle components and cards with care. Do not touch the components or contacts on a card. Hold a card by its edges or by its metal mounting bracket. Hold a component such as a processor by its edges, not by its pins.



NOTICE: Only a certified service technician should perform repairs on your computer. Damage due to servicing that is not authorized by Dell is not covered by your warranty.



NOTICE: When you disconnect a cable, pull on its connector or on its pull-tab, not on the cable itself. Some cables have connectors with locking tabs; if you are disconnecting this type of cable, press in on the locking tabs before you disconnect the cable. As you pull connectors apart, keep them evenly aligned to avoid bending any connector pins. Also, before you connect a cable, ensure that both connectors are correctly oriented and aligned.



NOTICE: To avoid damaging the computer, perform the following steps before you begin working inside the computer.

- 1 Ensure that the work surface is flat and clean to prevent the computer cover from being scratched.
- 2 Turn off your computer (see "Turning Off Your Computer" on page 151).

- ➔ **NOTICE:** To disconnect a network cable, first unplug the cable from your computer and then unplug the cable from the network device.
- 3 Disconnect all telephone or network cables from the computer.
- ➔ **NOTICE:** To avoid damaging the system board, you must remove the main battery before you service the computer.
- 4 Disconnect your computer and all attached devices from their electrical outlets.

Removing the Computer Cover and Front Panel

Removing the Computer Cover

- ⚠ **CAUTION:** Before you begin any of the procedures in this section, follow the safety instructions in the *Product Information Guide*.
- ⚠ **CAUTION:** To guard against electrical shock, always unplug your computer from the electrical outlet before removing the cover.
- ➔ **NOTICE:** To prevent static damage to components inside your computer, discharge static electricity from your body before you touch any of your computer's electronic components. You can do so by touching an unpainted metal surface on the computer.
- 1 Follow the procedures in "Before You Begin" on page 151.
- ➔ **NOTICE:** Opening the computer cover while the computer is running could result in a shutdown without warning and a loss of data in open programs. The computer cooling system cannot function properly while the cover is removed.
- 2 If you have installed a security cable, remove it from the security cable slot.
- ➔ **NOTICE:** Ensure that sufficient space exists to support the removed cover—at least 30 cm (1 ft) of desk top space.
- ➔ **NOTICE:** Ensure that you are working on a level, protected surface to avoid scratching either the computer or the surface on which it is resting.
- 3 Lay your computer on a flat surface with the cover facing up.
- 4 Pull back the cover latch release.
- 📎 **NOTE:** The computer in the following images is configured as a tower computer. See "Changing Between Tower and Desktop Modes" on page 30 for information regarding computer orientation.

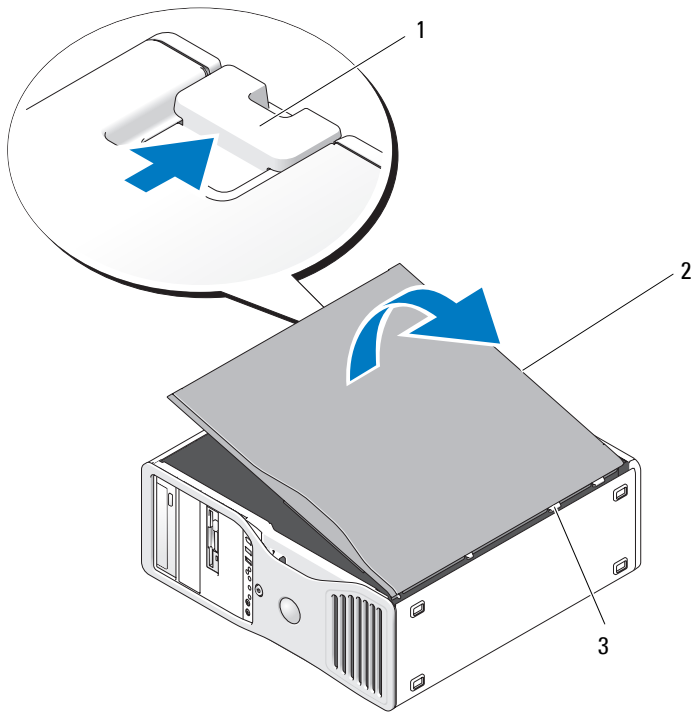

1 cover latch release

2 computer cover

3 cover hinges

- 5 Locate the three hinge tabs on the edge of the computer.
- 6 Grip the sides of the computer cover and pivot the cover up, using the hinges as leverage points.
- 7 Release the cover from the hinge tabs and set it aside in a secure location.



NOTICE: The computer cooling system cannot function properly while the computer cover is not installed. Do not attempt to boot the computer before replacing the computer cover.

Removing the Front Panel

 **CAUTION:** Before you begin any of the procedures in this section, follow the safety instructions in the *Product Information Guide*.

 **CAUTION:** To guard against electrical shock, always unplug your computer from the electrical outlet before removing the cover.

 **NOTICE:** To prevent static damage to components inside your computer, discharge static electricity from your body before you touch any of your computer's electronic components. You can do so by touching an unpainted metal surface on the computer.

- 1 Follow the procedures in "Before You Begin" on page 151.
- 2 Follow the procedures in "Removing the Computer Cover" on page 153.

 **NOTE:** The computer in the following images is configured as a tower computer. See "Changing Between Tower and Desktop Modes" on page 30 for information regarding computer orientation.

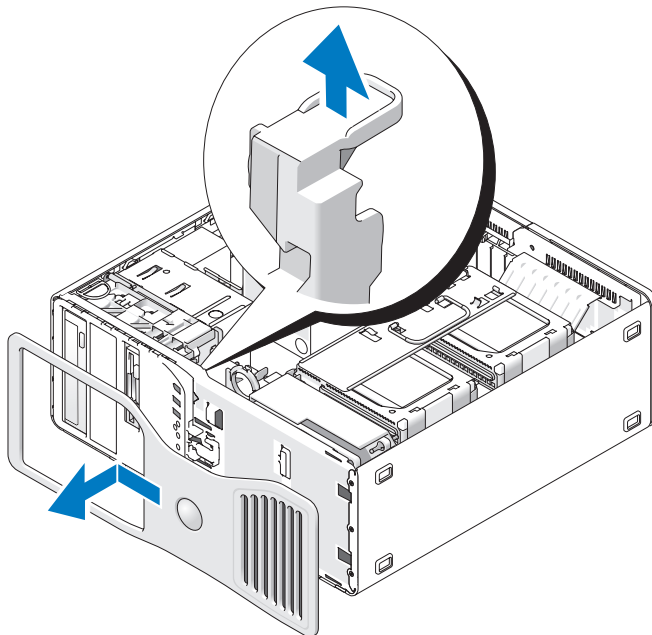

- 3 Lift the front-panel release lever.

- 4 Slide the front panel toward the top of the computer and then lift to remove the panel from the computer.

Rotating the Hard Drive Carrier Out of the Computer

- 1 Disconnect either side of the P3 power-cable bundle that is attached to the card retention mechanism: press the release latch on the P3 power-cable bundle connectors beside the power supply and pull the two connectors apart.

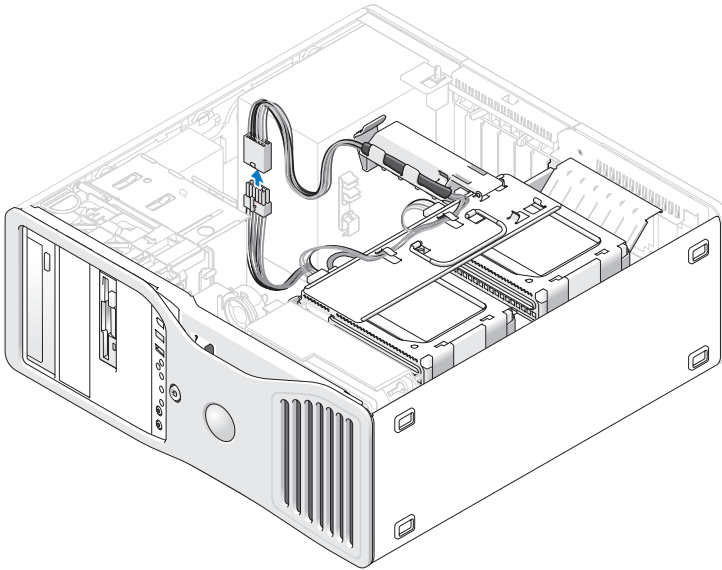

- 2 Press the card retention mechanism release-tab and rotate the card retention mechanism so that it rests against the rotatable hard-drive carrier.

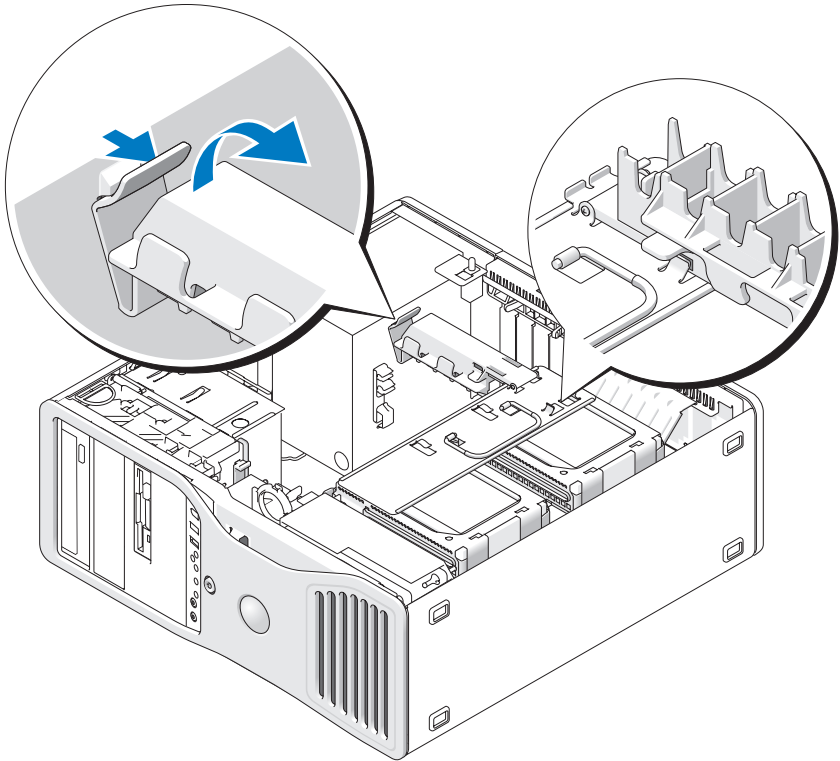

- 3** Press down against the card retention mechanism until it clicks into place, locked against the hard-drive carrier.

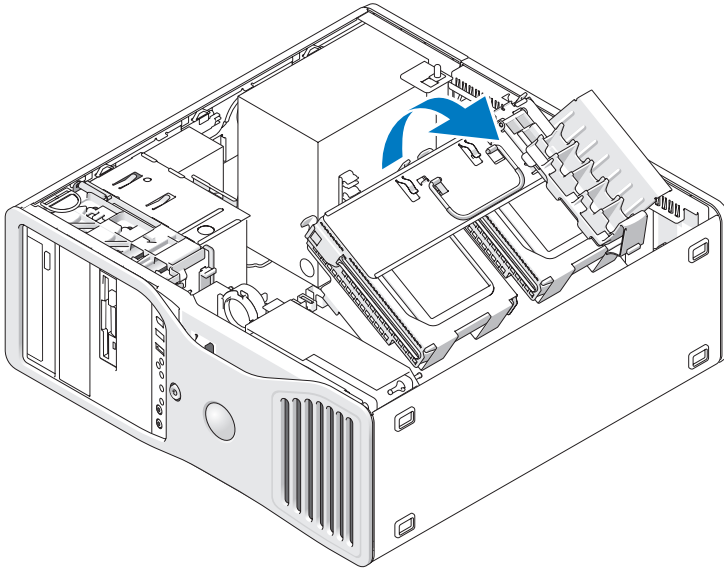

- 4 Grasp the handle on the hard-drive carrier and rotate the carrier out of the chassis so that it is at an angle of less than 180 degrees from its original position.

Replacing the Front Panel and Computer Cover



CAUTION: Before you begin any of the procedures in this section, follow the safety instructions in the *Product Information Guide*.



CAUTION: To guard against electrical shock, always unplug your computer from the electrical outlet before opening the cover.



NOTICE: To prevent static damage to components inside your computer, discharge static electricity from your body before you touch any of your computer's electronic components. You can do so by touching an unpainted metal surface on the computer.

Rotating the Hard-Drive Carrier Back into the Computer

- 1 Grasp the handle on the hard-drive carrier and rotate the carrier back into the chassis until the metal tabs on each side of the carrier are seated, securing the carrier.

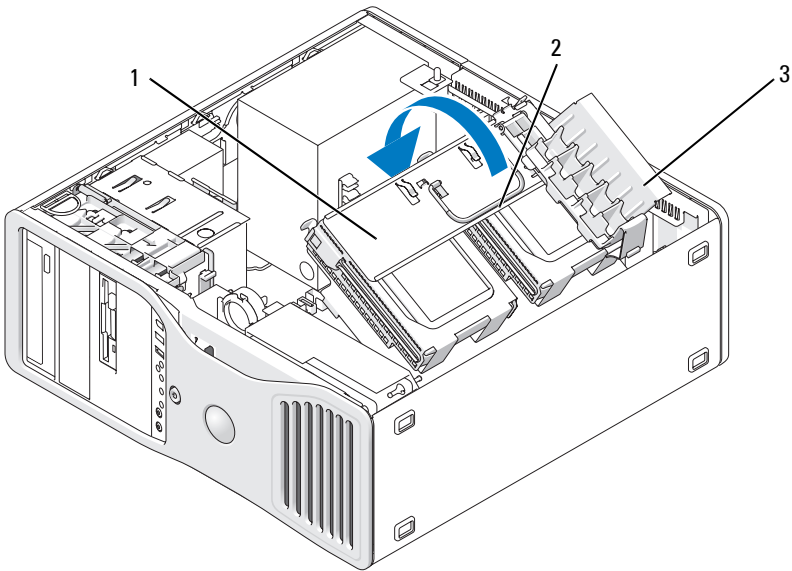

- 1 rotatable hard-drive carrier 2 handle
3 card-retention mechanism

- 2 Pull up on the card retention mechanism to release it from the hard-drive carrier.

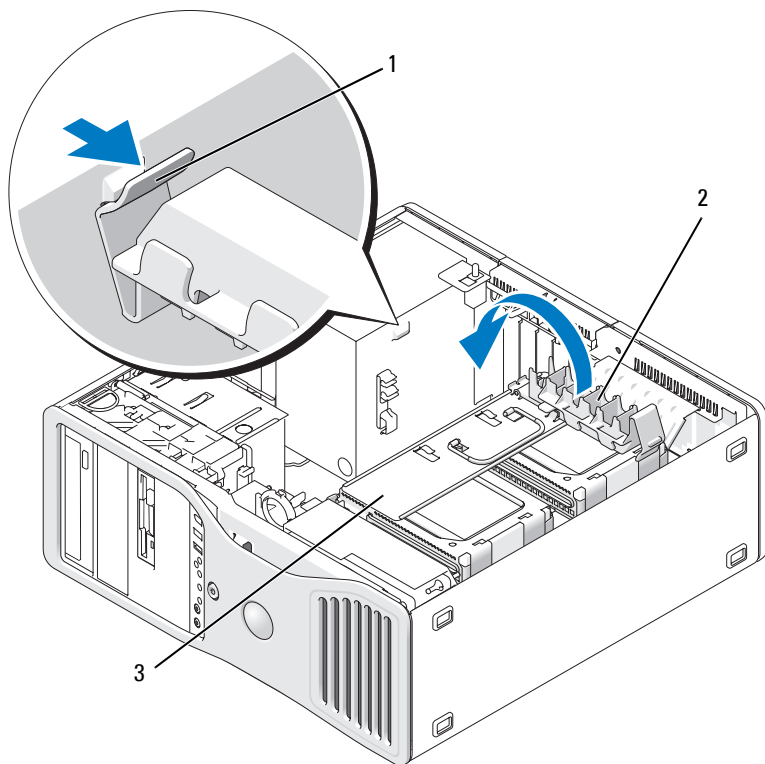

- 1 card-retention mechanism 2 card-retention mechanism tab
3 rotatable hard-drive carrier

- 3 Rotate the card retention mechanism back into its original position; push its tip so that its tab clicks into place.
- 4 Reconnect both sides of the P3 power-cable bundle that is attached to the card retention mechanism.

Replacing the Front Panel

- 1 Align the hooks on the front panel with the corresponding holes on the front of the computer.

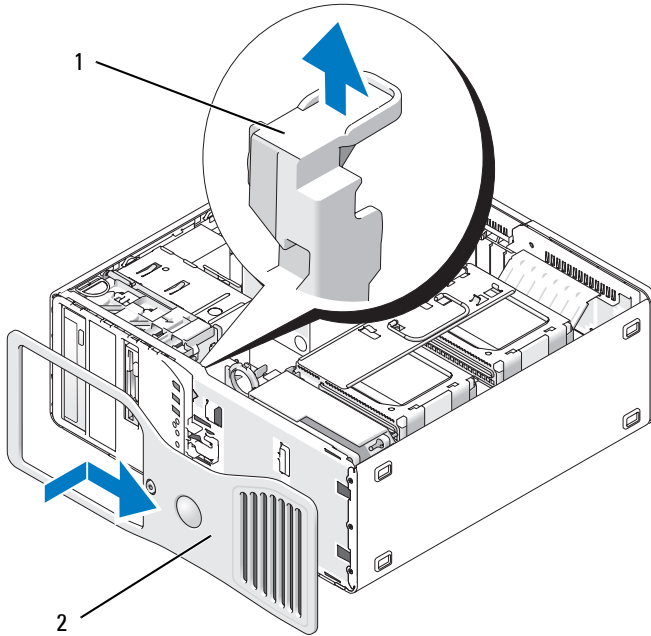

1 front-panel release lever 2 front panel

- 2 Pull the front-panel release lever, and slide the panel to the right to engage and secure the front panel.

Replacing the Computer Cover



NOTICE: The computer cooling system cannot function properly while the computer cover is not installed. Do not attempt to boot the computer before replacing the computer cover.

- 1 Ensure that all cables are connected, and fold cables out of the way. Gently pull the power cables toward you so that they do not get caught underneath the drives.
- 2 Ensure that no tools or extra parts are left inside the computer.
- 3 Replace the cover:

- a Align the computer cover with the tabs on the computer base.
- b Pivot the cover down and gently press the cover until it clicks into place.
- c Ensure that the cover is locked. If not, repeat all of step 3.

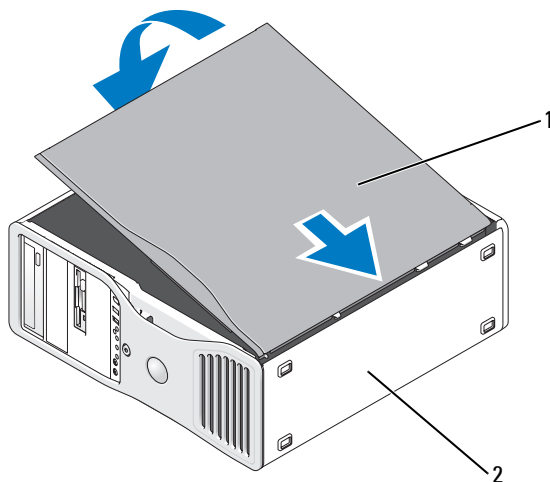

1 computer cover

2 computer base

- ➔ NOTICE:** To connect a network cable, first plug the cable into the network port or device and then plug it into the computer.
- 4 Connect your computer and devices to electrical outlets, and turn them on.
 - 5 After you open and close the cover, the chassis intrusion detector, if enabled, causes the following message to appear on the screen at the next computer start-up:
ALERT! Cover was previously removed.
 - 6 Reset the chassis intrusion detector by changing Intrusion Alert to Enabled or Enabled-Silent. See "Resetting the Chassis Intrusion Detector" on page 76.

- 7 If a setup password has been assigned by someone else, contact your network administrator for information on resetting the chassis intrusion detector.

I/O Panel



CAUTION: Before you begin any of the procedures in this section, follow the safety instructions in the *Product Information Guide*.



CAUTION: To guard against electrical shock, always unplug your computer from the electrical outlet before opening the cover.



NOTICE: To prevent static damage to components inside your computer, discharge static electricity from your body before you touch any of your computer's electronic components. You can do so by touching an unpainted metal surface on the computer.

I/O-Panel Components

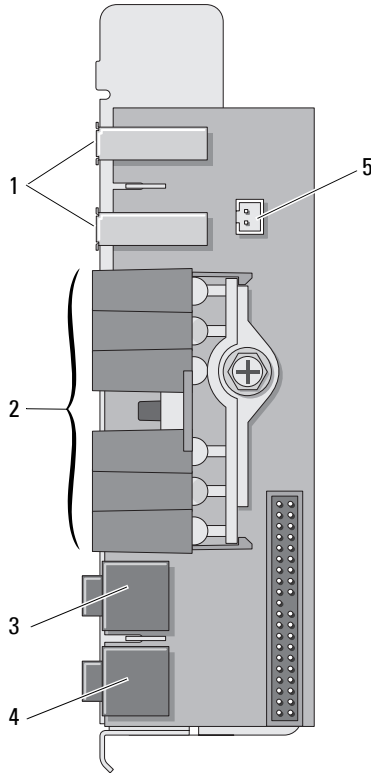

- 1 USB ports
- 2 diagnostic, hard-drive access, and network integrity lights
- 3 headphone connector
- 4 microphone connector
- 5 front-panel thermal diode connector

NOTE: The front-panel thermal diode cable must be installed in this connector at all times while your computer is running or thermal problems may result.

Removing the I/O Panel

- 1 Follow the procedures in "Before You Begin" on page 151.
- 2 Remove the computer cover (see "Removing the Computer Cover" on page 153).
- 3 Rotate the hard-drive carrier out of the computer (see "Rotating the Hard Drive Carrier Out of the Computer" on page 156).
- 4 Disconnect the card fan connector from the system board.

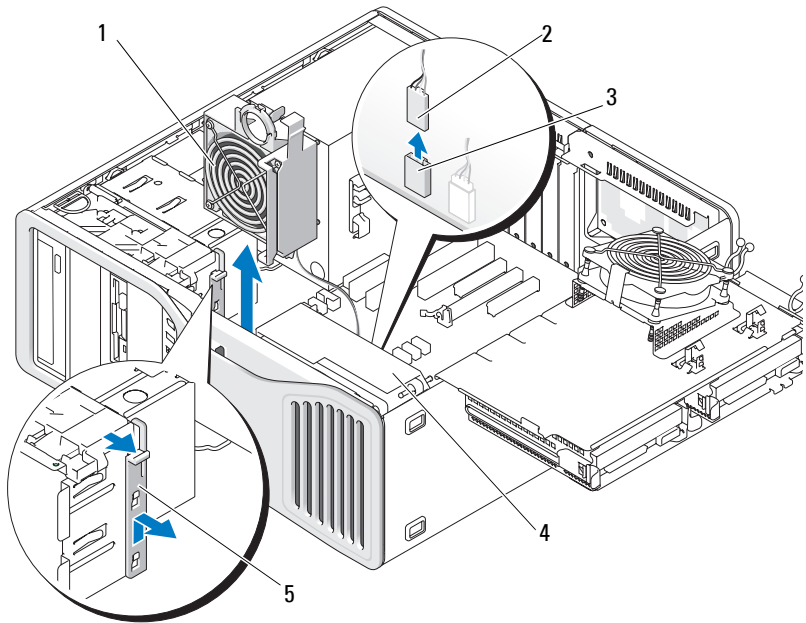

- | | | | |
|---|---|---|----------------|
| 1 | card fan | 2 | card fan cable |
| 3 | card fan connector (FAN_CCAG on system board) | 4 | front fan |
| 5 | full-length card retainer piece | | |
- 5 If the system is in tower mode, pull to remove the full-length card retainer piece beside the card fan.

- 6 Press the tab between the card fan and the front fan towards the card fan as you lift it up and out of the computer.
- ➔ **NOTICE:** Carefully note the routing of each cable before you disconnect it, so that you are sure to re-route cables correctly. An incorrectly routed or a disconnected cable could lead to computer problems.
- 7 Note the routing of each cable as you disconnect all cables attached to the I/O panel.

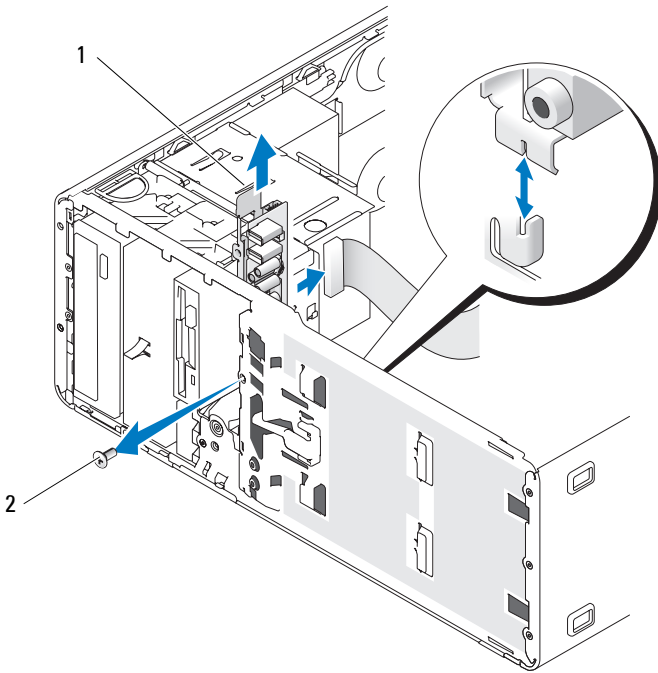

1 I/O panel

2 mounting screw

- 8 Remove the mounting screw from the I/O panel.
- 9 Remove the I/O panel from the computer.

Replacing the I/O Panel

➡ **NOTICE:** Ensure that you replace all cables originally attached to the I/O panel or you may experience computer problems.

- 1 Follow "Removing the I/O Panel" on page 165 in reverse order.

Power Supply

Power Supply DC Connector Pin Assignments

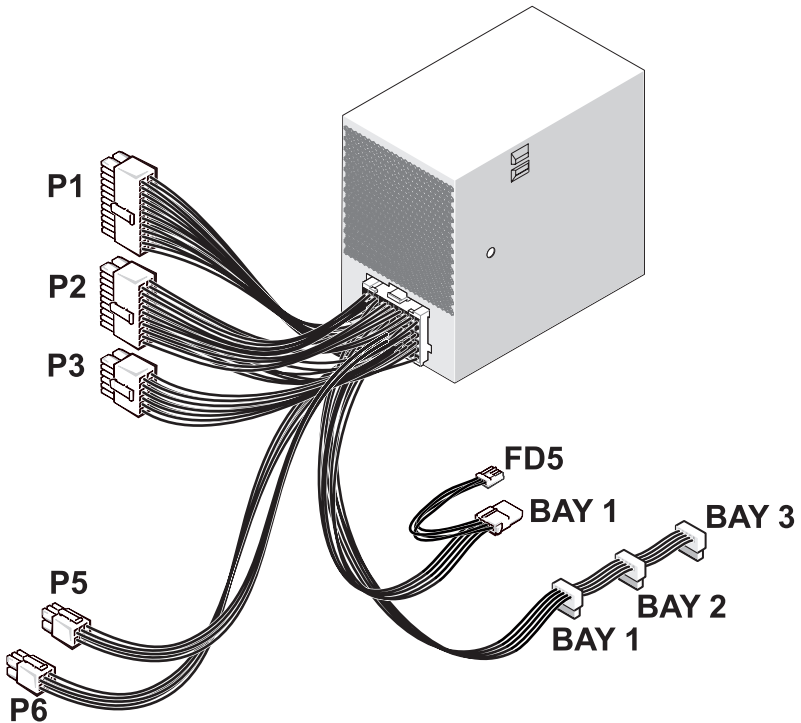

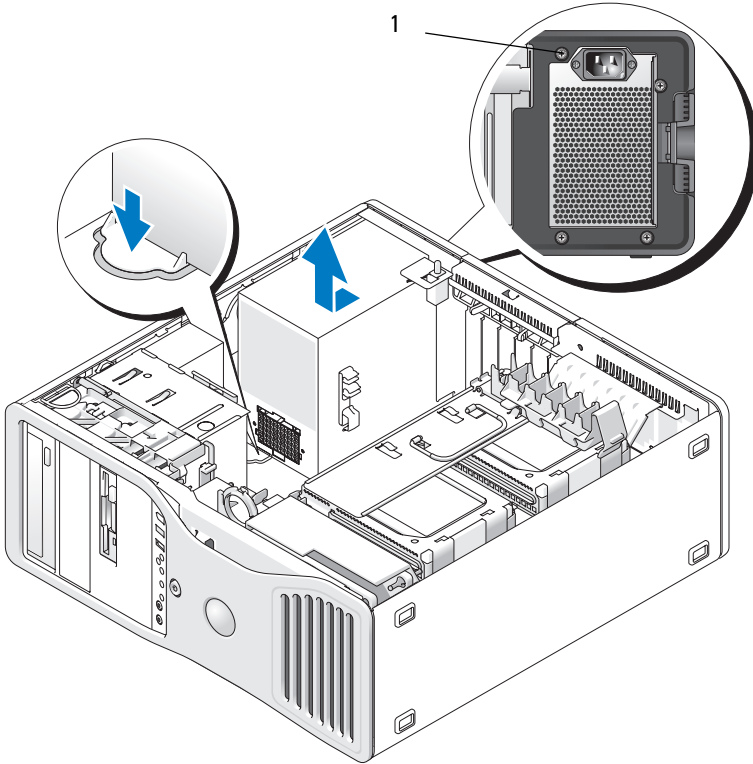

1 power supply screws (4)

DC Power Connectors P1

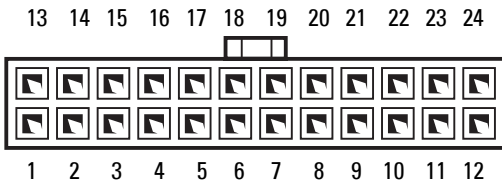

Pin Number	Signal name	18-AWG Wire
1	3.3 V	Orange
2	3.3 V	Orange
3	3.3 V	Orange
4	COM	Black
5	POK	Gray
6	5VSB	Purple
7	COM	Black
8	M12	Blue
9	12 VD	Yellow/ White
10	5 V	Red
11	5 V	Red
12	COM	Black
13	OPEN	
14	3.3 VSE	Orange
15	3.3 V	Orange
16	12 VD	Yellow/ White
17	PSON	Green
18	12 VD	Yellow/ White
19	COM	Black
20	COM	Black
21	FAN FAULT	Brown
22	5 V	Red
23	5 V	Red
24	COM	Black

DC Power Connectors P2

11 12 13 14 15 66 67 68 69 20

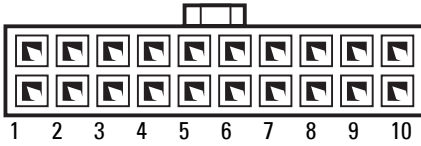

Pin Number	Signal Name	18-AWG Wire
1	12 VC	Blue/White
2	12 VC	Blue/White
3	COM	Black
4	COM	Black
5	12 VA	Yellow
6	12 VA	Yellow
7	COM	Black
8	COM	Black
9	12 VB	White
10	12 VB	White
11	12 VC	Blue/White
12	COM	Black
13	COM	Black
14	COM	Black
15	12 VA	Yellow
16	COM	Black
17	COM	Black
18	COM	Black
19	12 VB	White
20	OPEN	

DC Power Connector P3

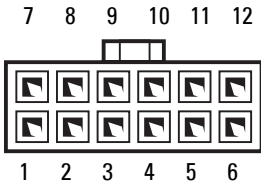

Pin Number	Signal name	18-AWG Wire
1	COM	Black
2	12 VC	Blue/White
3	12 VC	Blue/White
4	COM	Black
5	COM	Black
6	5 V	Red
7	5 V	Red
8	3.3 V	Orange
9	12 VC	Blue/White
10	COM	Black
11	COM	Black
12	5 V	Red

DC Power Connector P5

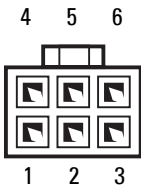

Pin Number	Signal name	18-AWG Wire
1	12 VD	Yellow/White
2	12 VD	Yellow/White
3	12 VD	Yellow/White
4	COM	Black
5	COM	Black
6	COM	Black

DC Power Connector P6



Pin Number	Signal name	18-AWG Wire
1	12 VE	Blue/Yellow
2	12 VE	Blue/Yellow
3	12 VE	Blue/Yellow
4	COM	Black
5	COM	Black
6	COM	Black

DC Power Connector FD5

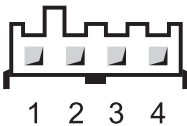

Pin Number	Signal name	18-AWG Wire
1	5 V	Red
2	COM	Black
3	COM	Black
4	12 VC	Blue/White

DC Power Connector Bay 1 (PATA)

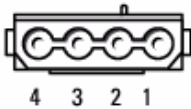

Pin Number	Signal name	18-AWG Wire
1	12 VC	Blue/White
2	COM	Black
3	COM	Black
4	5 V	Red

DC Power Connectors Bays 1, 2, and 3 (SATA)

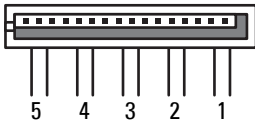

Pin Number	Signal name	18-AWG Wire
1	3.3 V	Orange
2	COM	Black
3	5V	Red
4	COM	Black
5	12 VC	Blue/White

Removing the Power Supply



CAUTION: Before performing any of the procedures in this section, follow the safety instructions in the *Product Information Guide*.



CAUTION: To guard against electrical shock, always unplug your computer from the electrical outlet before opening the cover.



NOTICE: To prevent static damage to components inside your computer, discharge static electricity from your body before you touch any of your computer's electronic components. You can do so by touching an unpainted metal surface on the computer.

- 1 Follow the procedures in "Before You Begin" on page 151.
- 2 Remove the computer cover. See "Removing the Computer Cover" on page 153.
- 3 Disconnect the cables from the power supply.
- 4 Remove the four screws that attach the power supply to the back of the computer chassis.

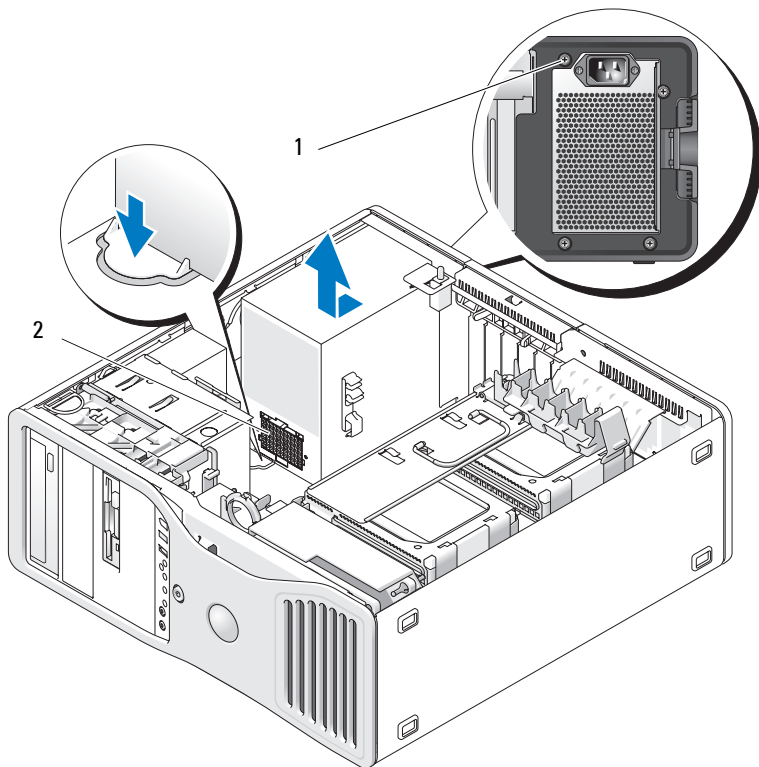





1 power supply screws (4) 2 power cable harness connector

- 5 Slide the power supply toward the front of the computer by approximately one inch.
- 6 Lift the power supply out of the computer.

Replacing the Power Supply

- 1 Slide the power supply into place.
 - 2 Replace the four screws that secure the power supply to the back of the computer chassis.
 - 3 Reconnect the DC power cables.
 - 4 On the desktop computer, reattach the power cables to the side of the hard drive.
 - 5 Run the cables underneath the tabs, and press the tabs to close them over the cables.
 - 6 Replace the computer cover (see "Replacing the Computer Cover" on page 161).
-  **NOTICE:** To connect a network cable, first plug the cable into the network port or device and then plug it into the computer.
- 7 Connect your computer and devices to electrical outlets, and turn them on.

Battery

-  **CAUTION:** Before you begin any of the procedures in this section, follow the safety instructions in the *Product Information Guide*.
-  **CAUTION:** To guard against electrical shock, always unplug your computer from the electrical outlet before opening the cover.
-  **CAUTION:** A new battery can explode if it is incorrectly installed. Replace the battery only with the same or equivalent type recommended by the manufacturer. Discard used batteries according to the manufacturer's instructions.
-  **NOTICE:** To prevent static damage to components inside your computer, discharge static electricity from your body before you touch any of your computer's electronic components. You can do so by touching an unpainted metal surface on the computer.

About the Battery

A coin-cell battery maintains computer configuration, date, and time information. The battery can last several years.

The battery may need replacing if you have repeatedly reset the time and date information after turning on the computer or if one of the following messages appear:

```
Time-of-day not set - please run SETUP program
```

or

```
Invalid configuration information -  
please run SETUP program
```

or

```
Strike the F1 key to continue,  
F2 to run the setup utility
```

To determine whether you need to replace the battery, re-enter the time and date in system setup and exit the program to save the information. Turn off your computer and disconnect it from the electrical outlet for a few hours; then reconnect the computer, turn it on, and enter the system setup program (see "System Setup" on page 89). If the date and time are not correct in system setup, replace the battery.

You can operate your computer without a battery; however, without a battery, the configuration information is erased if the computer is turned off or unplugged from the electrical outlet. In this case, you must enter the system setup program (see "System Setup" on page 89) and reset the configuration options.

Replacing the Battery

- 1 If you have not already done so, write down the configuration information found in system setup (see "System Setup" on page 89).
- 2 Follow the procedures in "Before You Begin" on page 151.
- 3 Remove the computer cover (see "Removing the Computer Cover" on page 153).
- 4 Locate the battery socket (see "System Board Components" on page 28).
- 5 If necessary, disconnect any cables that block access to the battery socket.

➔ **NOTICE:** If you pry the battery out of its socket with a blunt object, be careful not to touch the system board with the object. Ensure that the object is inserted between the battery and the socket before you attempt to pry out the battery. Otherwise, you may damage the system board by prying off the socket or by breaking circuit traces on the system board.

➔ **NOTICE:** To avoid damage to the battery connector, you must firmly support the connector while removing the battery.

- 6 Support the battery connector by pressing down firmly on the positive side of the connector.
- 7 While supporting the battery connector, press the battery tab away from the positive side of the connector and pry the battery up out of the securing tabs at the negative side of the connector.

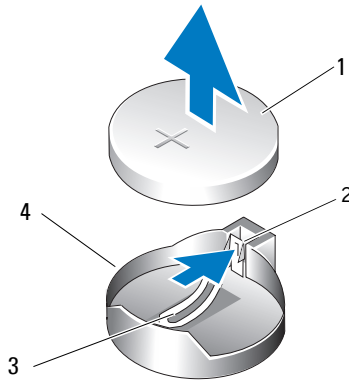

- | | |
|----------------------|--------------------------------------|
| 1 system battery | 2 positive side of battery connector |
| 3 battery socket tab | 4 battery socket |

➔ **NOTICE:** To avoid damage to the battery connector, you must firmly support the connector while replacing the battery.

- 8 Support the battery connector by pressing down firmly on the positive side of the connector.
- 9 Hold the battery with the "+" facing up, and slide it under the securing tabs at the positive side of the connector.
- 10 Press the battery straight down into the connector until it snaps into place.

- 11 Replace the computer cover (see "Replacing the Computer Cover" on page 161).
-  **NOTICE:** To connect a network cable, first plug the cable into the network device and then plug it into the computer.
- 12 Connect your computer and devices to electrical outlets, and turn them on.
- 13 Enter the system setup program (see "System Setup" on page 89) and restore the settings that you recorded in step 1.
- 14 Properly dispose of the old battery. For more information, see your *Product Information Guide*.

Processor



CAUTION: Before you begin any of the procedures in this section, follow the safety instructions in the *Product Information Guide*.



CAUTION: To guard against electrical shock, always unplug your computer from the electrical outlet before opening the cover.



NOTICE: To prevent static damage to components inside your computer, discharge static electricity from your body before you touch any of your computer's electronic components. You can do so by touching an unpainted metal surface on the computer.

Removing the Processor

- 1 Follow the procedures in "Before You Begin" on page 151.
- 2 Remove the computer cover (see "Removing the Computer Cover" on page 153).
- 3 Rotate the hard-drive carrier out of the computer (see "Rotating the Hard Drive Carrier Out of the Computer" on page 156).
- 4 Rotate the processor access door to its open position.

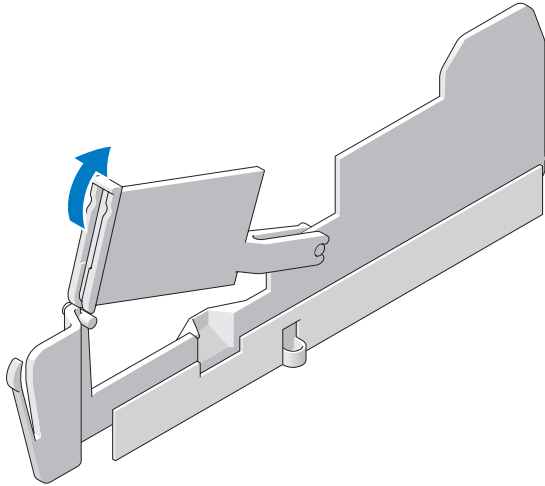

 **NOTE:** To loosen the four captive screws on the sides of the heat-sink assembly, you need a long Phillips screwdriver.

5 Loosen the four captive screws on the sides of the heat-sink assembly.

 **CAUTION:** The heat-sink assembly may become very hot during normal operation. Ensure that it has had sufficient time to cool before you touch it.

6 Lift to remove the heat-sink assembly from the computer.

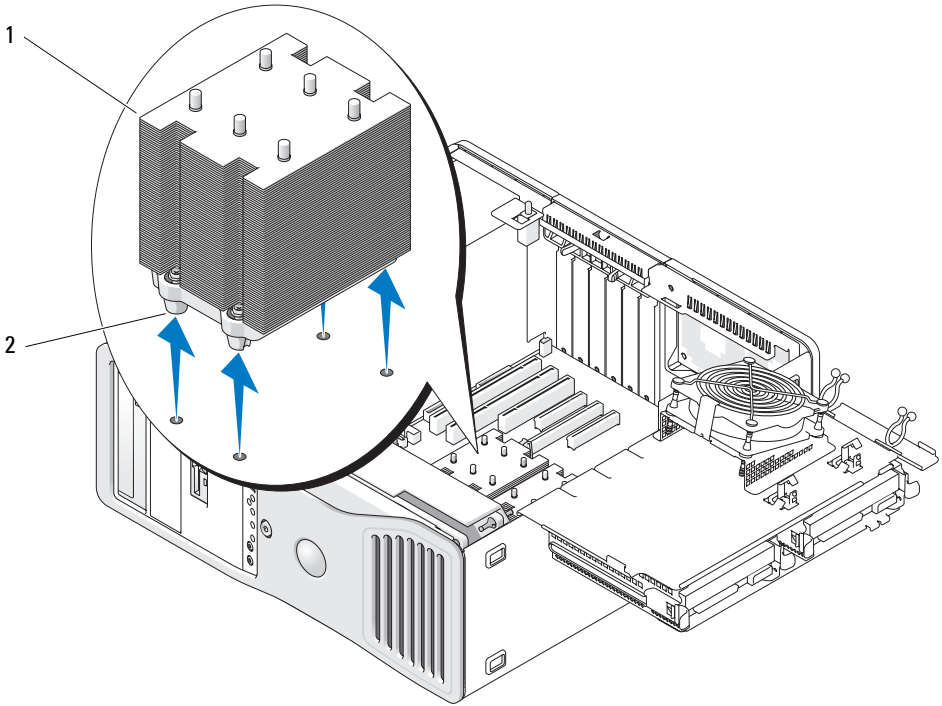

1 heat-sink assembly

2 captive screw housing (4)



NOTICE: If you are installing a processor upgrade kit from Dell, return the original heat-sink assembly and processor to Dell in the same package in which your replacement kit was sent. If you are not installing a processor upgrade kit from Dell, reuse the original heat-sink assembly when you install your new processor.

- 7 Open the processor cover by sliding the release lever from under the center cover latch on the socket. Then, pull the lever back to release the processor.

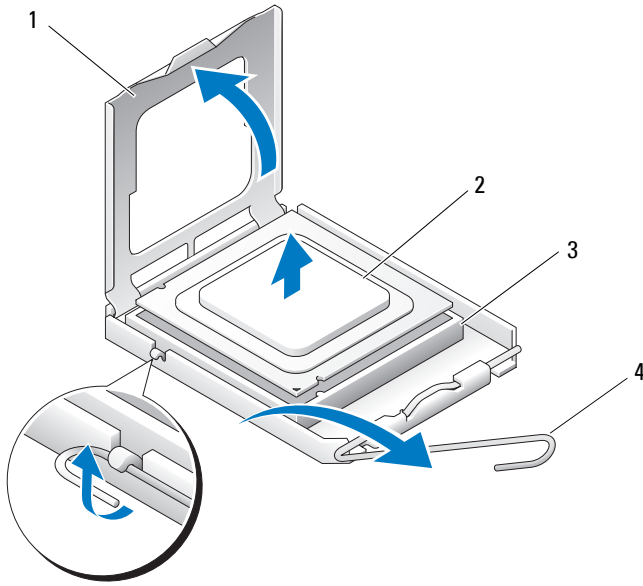

1 processor cover
3 socket

2 processor
4 release lever

➔ NOTICE: When replacing the processor, do not touch any of the pins inside the socket or allow any objects to fall on the pins in the socket.

- 8 Gently remove the processor from the socket.
- 9 If you are installing a new processor, leave the release lever extended in the release position so that the socket is ready for the new processor. See "Installing the Processor" on page 183.
Otherwise, continue with step 10.
- 10 Close the processor access door.
- 11 Ensure that all connectors are properly cabled and firmly seated.
- 12 Rotate the hard-drive carrier back into place (see "Rotating the Hard-Drive Carrier Back into the Computer" on page 159).
- 13 Replace the computer cover (see "Replacing the Computer Cover" on page 161).

Installing the Processor

- ➡ **NOTICE:** Ground yourself by touching an unpainted metal surface on the back of the computer.
- ➡ **NOTICE:** When replacing the processor, do not touch any of the pins inside the socket or allow any objects to fall on the pins in the socket.
 - 1 Follow the procedures in "Before You Begin" on page 151.
 - 2 Remove the computer cover (see "Removing the Computer Cover" on page 153).
 - 3 Rotate the hard-drive carrier out of the computer (see "Rotating the Hard Drive Carrier Out of the Computer" on page 156).
 - 4 Rotate the processor access door to its open position.
 - 5 If you are replacing a processor, remove the processor (see "Removing the Processor" on page 179).
 - 6 Unpack the new processor, being careful not to touch the underside of the processor.
- ➡ **NOTICE:** You must position the processor correctly in the socket to avoid permanent damage to the processor and the computer when you turn on the computer.
 - 7 Open the processor cover by sliding the release lever from under the center cover latch on the socket. Ensure that the release lever is fully extended.

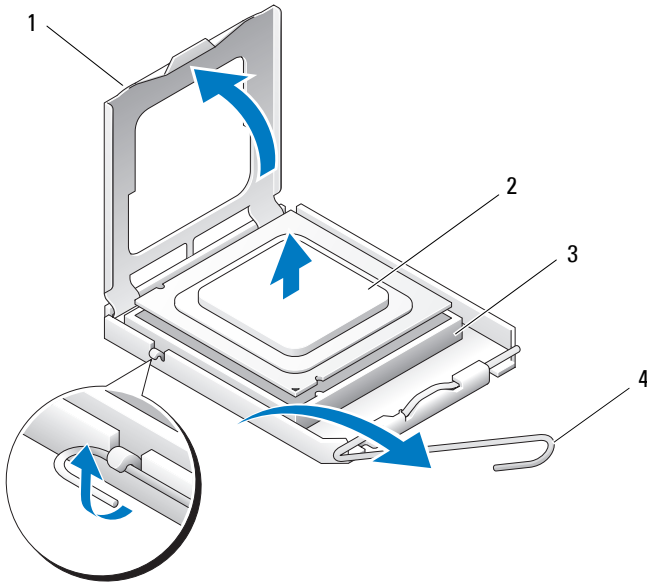

1 processor cover
3 socket

2 processor
4 release lever

- 8 Orient the front and rear alignment notches on the processor with the front and rear alignment notches on the socket.
- 9 Align the pin-1 corners of the processor and socket.

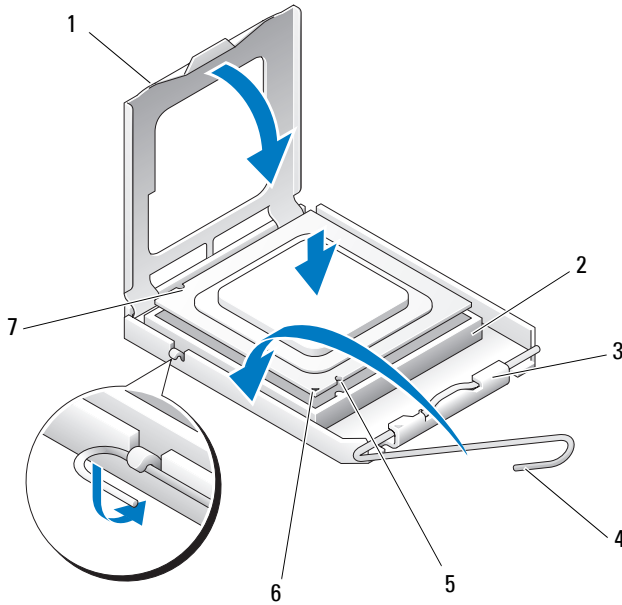

- | | | | |
|---|-----------------------|---|--------------------------------------|
| 1 | tab | 2 | processor socket |
| 3 | center cover latch | 4 | socket release lever |
| 5 | front alignment notch | 6 | socket and processor pin-1 indicator |
| 7 | rear alignment notch | | |

NOTICE: To avoid damage, ensure that the processor aligns properly with the socket, and do not use excessive force when you install the processor.

- 10** Set the processor lightly in the socket and ensure that the processor is positioned correctly.
- 11** When the processor is fully seated in the socket, close the processor cover.

Ensure that the tab on the processor cover is positioned underneath the center cover latch on the socket.

- 12** Pivot the socket release lever back toward the socket and snap it into place to secure the processor.

- ➔ **NOTICE:** If you are *not* installing a processor upgrade kit from Dell, reuse the original heat-sink assembly when you replace the processor.

If you installed a processor replacement kit from Dell, return the original heat-sink assembly and processor to Dell in the same package in which your replacement kit was sent.

13 Install the heat-sink assembly:

- a Place the heat-sink assembly back onto the heat-sink assembly bracket.
- b Rotate the heat-sink assembly down towards the computer base and tighten the four capture screws.

- ➔ **NOTICE:** Ensure that the heat-sink assembly is correctly seated and secure.

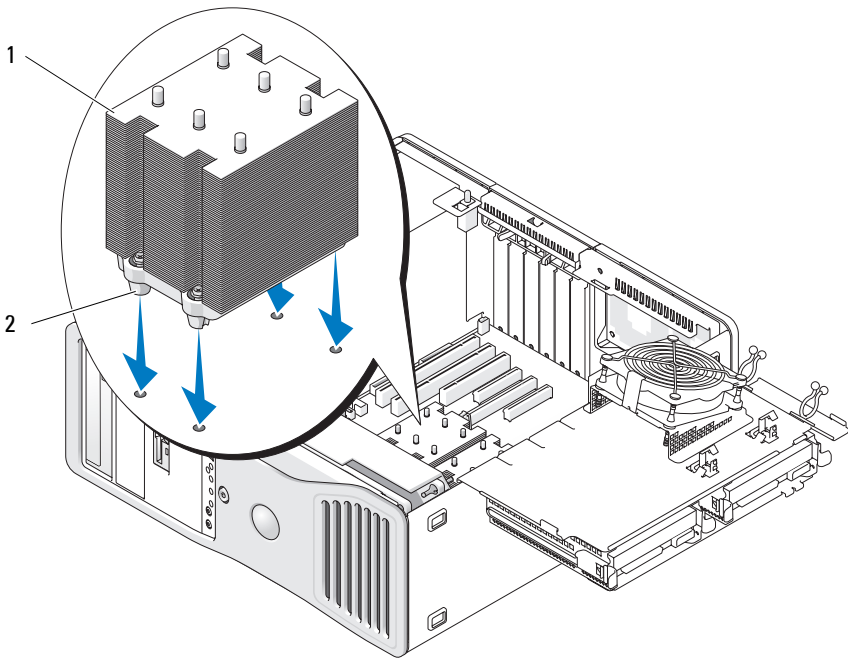

1 heat-sink assembly

2 captive screw housing (4)

14 Close the processor access door.

- 15 Ensure that all connectors are properly cabled and firmly seated.
 - 16 Rotate the hard-drive carrier back into place (see "Rotating the Hard-Drive Carrier Back into the Computer" on page 159).
 - 17 Replace the computer cover (see "Replacing the Computer Cover" on page 161).
-  **NOTICE:** To connect a network cable, first plug the cable into the network port or device and then plug it into the computer.
- 18 Connect the computer and devices to electrical outlets, and turn them on.

Memory

Your computer supports fully-buffered ECC DDR2 memory only. For more information on the type of memory supported by your computer, see "Specifications" on page 36.

 **NOTICE:** Before you install new memory modules, download the most recent BIOS for your computer from the Dell Support website at support.dell.com.

 **NOTE:** Memory purchased from Dell is covered under your computer warranty.

Fully Buffered DIMM (FBD) Memory Overview

For optimal performance, fully buffered DIMMs (FBDs) should be installed in matched sets of four. This enables quad-channel operation and provides the highest memory bandwidth. The sets of four must be matched in size, rank, and organization. This information can normally be found on the FBD label. For example, the label of each FBD in a set of four might read: *1G 2R x8*, in which *1G* represents the size of the memory module, *2R* represents the number of ranks, and *x8* represents the organization.

 **NOTICE:** Full-length heat spreaders (FLHS) are required for 667 MHz DIMMs.

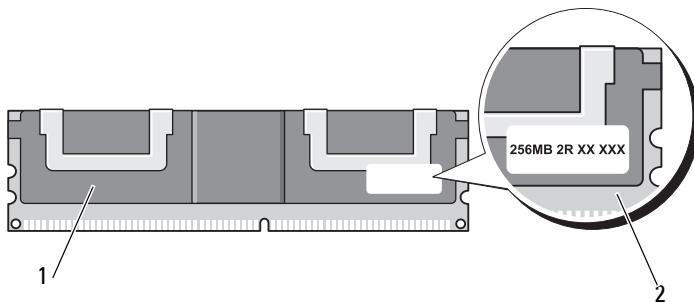

1 fully buffered DIMM

2 information label

Memory Installation

Fully buffered DDR2 memory modules can also be installed in pairs of two; in this case, the computer will continue to operate, but with a slight reduction in performance. The pairs must be matched in size, rank, and organization.

Install memory modules in order of their labels on the system board; matched sets of four should be installed first into DIMM slots 1-4 and then into DIMM slots 5-8 on the system board. Pairs of memory should be first installed into slots DIMM_1, and DIMM_2, then DIMM_3 and DIMM_4, and so on.



NOTICE: Do not install non-ECC or unbuffered memory modules. Doing so may cause the computer not to boot.



NOTE: DIMM slots 1-4 have white latches for easy identification. DIMM slot 5-8 have black latches.

Addressing Memory With 4-GB or Greater Configurations (32-bit Operating Systems Only)

This computer supports a maximum of 32 GB of memory when eight 4-GB DIMMs are installed. Current 32-bit operating systems, such as Microsoft® Windows® XP and Windows™ Vista, can use a maximum of 4 GB of address space; however, the amount of memory available to the operating system is

less than that installed. Certain components within the computer require address space in the 4-GB range. Any address space reserved for these components cannot be used by computer memory.

The following components require memory address space:

- System ROM
- APIC(s)
- Integrated PCI devices, such as network connectors and SCSI controllers
- PCI cards
- Graphics card
- PCI Express cards (if applicable)

At start-up, the BIOS identifies the components that require address space. The BIOS dynamically calculates the amount of reserved address space required. The BIOS then subtracts the reserved address space from 4 GB to determine the amount of usable space.

- If the total installed computer memory is less than the usable address space, all installed computer memory is available for use only by the operating system.
- If the total installed computer memory is equal to or greater than the usable address space, a portion of installed memory is not available for use by the operating system.

Removing Memory



CAUTION: Before you begin any of the procedures in this section, follow the safety instructions in the *Product Information Guide*.



NOTICE: If you remove your original memory modules from the computer during a memory upgrade, keep them separate from any new modules that you may have, even if you purchased the new modules from Dell. If possible, *do not* pair an original memory module with a new memory module. Otherwise, your computer may not start properly.



NOTICE: To prevent static damage to components inside your computer, discharge static electricity from your body before you touch any of your computer's electronic components. You can do so by touching an unpainted metal surface on the computer chassis



NOTE: Memory purchased from Dell is covered under your computer warranty.

- 1 Follow the procedures in "Before You Begin" on page 151.
- 2 Remove the computer cover (see "Removing the Computer Cover" on page 153).
- 3 Rotate the hard-drive carrier out of the computer (see "Rotating the Hard-Drive Carrier Back into the Computer" on page 159).

⚠ CAUTION: Fully-buffered memory modules may become very hot during normal operation. Ensure that memory modules have had sufficient time to cool before you touch them.

- 4 Press out the securing clip at each end of the memory module connector.

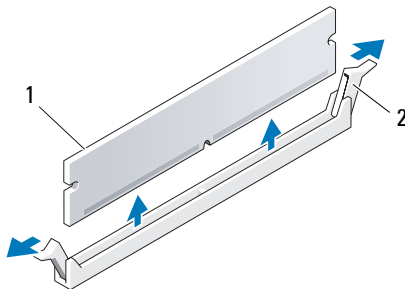

1 memory module

2 securing clip (2)

- 5 Grasp the module and pull up to lift the memory module from the memory riser card.
If a module is difficult to remove, gently ease it back and forth to remove it from the connector.
- 6 Rotate the hard-drive carrier back into place (see "Rotating the Hard-Drive Carrier Back into the Computer" on page 159).
- 7 Replace the computer cover (see "Replacing the Computer Cover" on page 161).

Installing Memory

⚠ CAUTION: Before you begin any of the procedures in this section, follow the safety instructions in the *Product Information Guide*.

➔ NOTICE: To prevent static damage to components inside your computer, discharge static electricity from your body before you touch any of your computer's electronic components. You can do so by touching an unpainted metal surface on the computer chassis.

1 Follow the procedures in "Before You Begin" on page 151.

➔ NOTICE: Before you install new memory modules, download the most recent BIOS for your computer from the Dell Support website at support.dell.com.

2 Remove the computer cover (see "Removing the Computer Cover" on page 153).

3 Rotate the hard-drive carrier out of the computer (see "Rotating the Hard Drive Carrier Out of the Computer" on page 156).

4 If you are replacing a memory module, see "Removing Memory" on page 189.

⚠ CAUTION: Fully-buffered memory modules may become very hot during normal operation. Ensure that memory modules have had sufficient time to cool before you touch them.

5 Press out the securing clip at each end of the memory module connector.

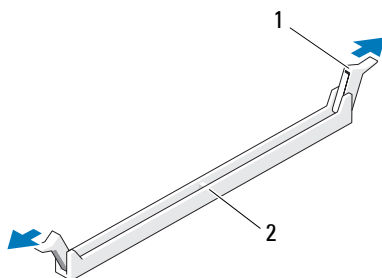

1 securing clips (2)

2 memory connector

➔ NOTICE: Full-length heat spreaders (FLHS) are required for 667 MHz DIMMs.

6 Align the notch on the bottom of the module with the crossbar in the connector.

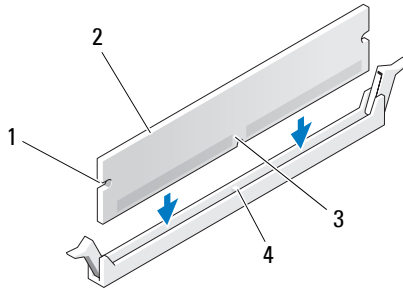

- | | | | |
|---|-------------|---|---------------|
| 1 | cutouts (2) | 2 | memory module |
| 3 | notch | 4 | crossbar |

➔ NOTICE: To avoid damage to the memory module, press the module straight down into the connector while you apply equal force to each end of the module.

- 7** Insert the module into the connector until the module snaps into position. If you insert the module correctly, the securing clips snap into the cutouts at each end of the module.

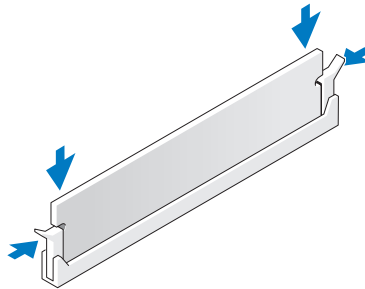

- 8** Rotate the hard-drive carrier back into place (see "Rotating the Hard-Drive Carrier Back into the Computer" on page 159).
- 9** Replace the computer cover (see "Replacing the Computer Cover" on page 161).
- 10** Connect your computer and devices to electrical outlets, and turn them on.

- 11 Press <F2> to enter the system setup program and check the values listed under **Memory Info**.

The computer should have changed the value of **Installed Memory** to reflect the newly installed memory. Verify the new total. If it is correct, skip to step 13.

- 12 If the memory total is incorrect, turn off and disconnect your computer and devices from their electrical outlets.

Return to step 1 of this procedure, but instead of installing new memory, check the installed memory modules to ensure that they are seated properly in their sockets.

- 13 When the **Installed Memory** total is correct, press <Esc> to exit system setup.

- 14 Run the Dell Diagnostics (see "Dell Diagnostics" on page 136) to verify that the memory modules are operating properly.

Cards



CAUTION: Before you begin any of the procedures in this section, follow the safety instructions in the *Product Information Guide*.



CAUTION: To guard against electrical shock, always unplug your computer from the electrical outlet before opening the cover.



NOTICE: To prevent static damage to components inside your computer, discharge static electricity from your body before you touch any of your computer's electronic components. You can do so by touching an unpainted metal surface on the computer.

Expansion Card Support

Your Dell™ computer provides the following slots for PCI and PCI Express cards:

- One PCI card slot
- One PCI Express x16 card slot
- Two PCI Express x8 card slots (wired as x4)
- Two PCI-X card slots

Desktop Mode: Slots 2-4 support full-length cards (1 PCI Express x16 slot, one PCI Express x8 slot, and one PCI slot), and slots 1, 5, and 6 support half-length cards (2 PCI-X slots, and 1 PCI Express x8 slot).

Tower Mode: Slots 2-5 support full-length cards (1 PCI-X slot, one PCI Express x8 slot, 1 PCI Express x16 slot, and one PCI slot), and slots 1 and 6 support half-length cards (1 PCI-X slot and 1 PCI Express x8 slot).

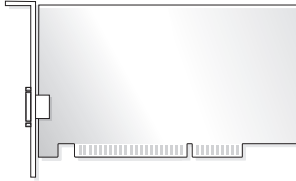

If you are installing or replacing a PCI, PCI Express, or PCI-X card, see "Installing an Expansion Card" on page 194. If you are removing but not replacing a PCI, PCI Express, or PCI-X card, see "Removing an Expansion Card" on page 201.

Before installing a card, see the documentation that came with the card for information on configuring the card, making internal connections, or otherwise customizing it for your computer. If you are replacing a card, uninstall the existing driver for the card.

Installing an Expansion Card

- 1 Follow the procedures in "Before You Begin" on page 151.
- 2 Remove the computer cover (see "Removing the Computer Cover" on page 153).
- 3 Rotate the hard-drive carrier out of the computer (see "Rotating the Hard Drive Carrier Out of the Computer" on page 156).
- 4 Press the release tabs on the card retention door towards each other and pivot the door open.
Because the door is captive, it will remain in the open position.

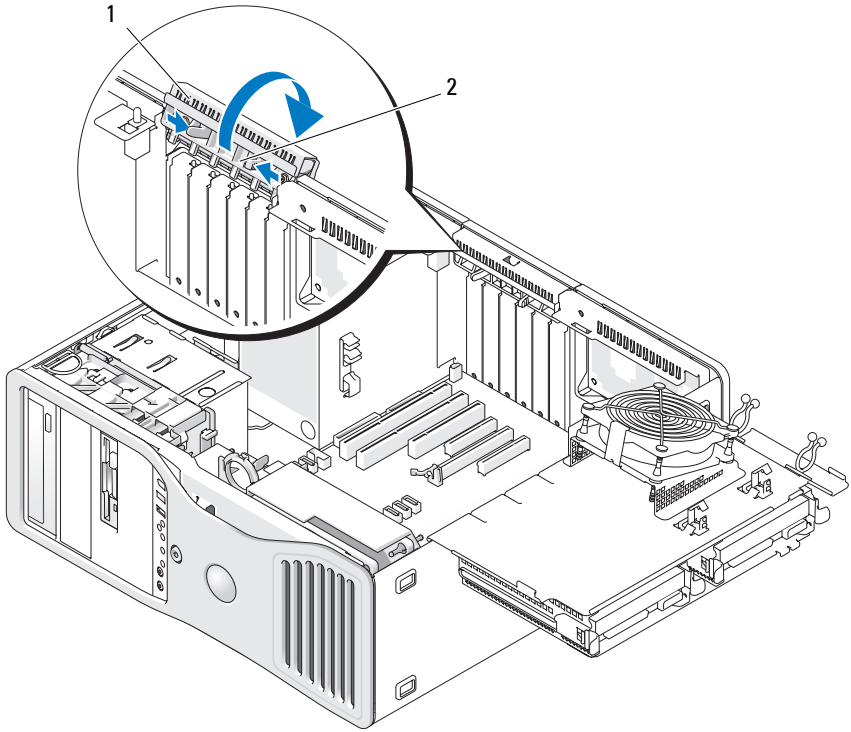

1 card retention door

2 release tab

- 5 If you are installing a new card, remove the filler bracket to create a card-slot opening. Then continue with step 7.

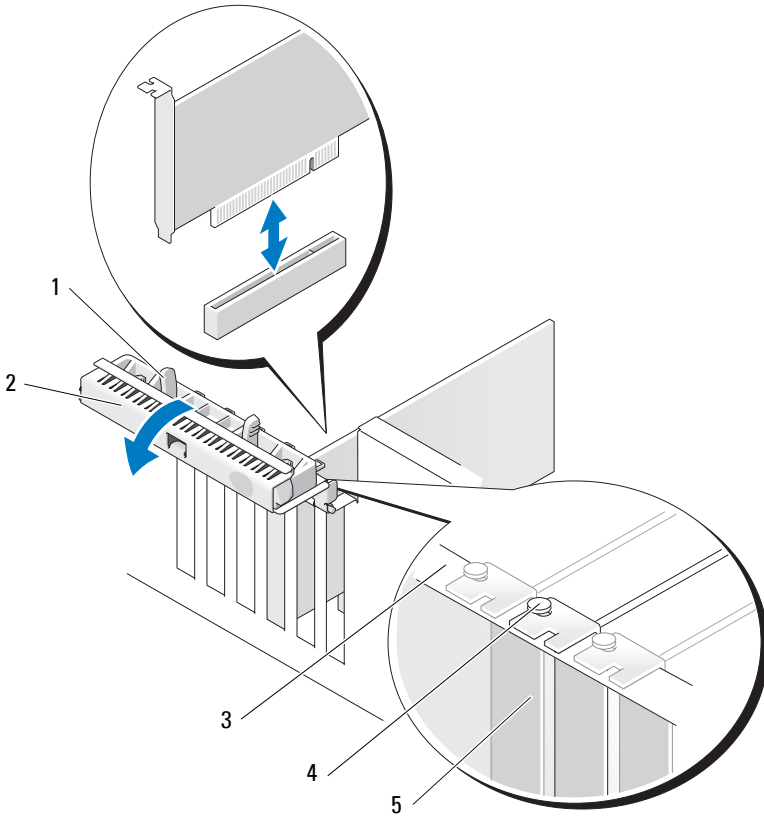

- 1 release tab
- 3 alignment bar

- 2 card retention door
- 4 alignment guide

- 5 filler bracket

NOTE: For extra security, remove the alignment guide (an upside-down screw) and screw it in right side up to secure a card.

➔ NOTICE: Ensure that you release the securing tab to unseat the card. If the card is not removed correctly, the system board may be damaged.

- 6 If you are replacing a card that is already installed in the computer, remove the card:
 - a If necessary, disconnect any cables connected to the card.
 - b If the card is full-length, press the release tab on the end of the alignment guides on the fan case.
 - c If the connector has a release tab, press the release tab as you grasp the card by its top corners, and ease it out of its connector.
- 7 Prepare the card for installation.

See the documentation that came with the card for information on configuring the card, making internal connections, or otherwise customizing it for your computer.



CAUTION: Some network adapters automatically start the computer when they are connected to a network. To guard against electrical shock, be sure to unplug your computer from its electrical outlet before installing any cards.

- 8 If the card is full-length, align it between the plastic card guides on the card fan case.
- 9 Position the card so that it is aligned with the slot and the securing tab (if present) is aligned with the securing slot.
- 10 Place the card in the connector and press down firmly. Ensure that the card is fully seated in the slot

If there is a release tab on the card slot, pull the release tab.

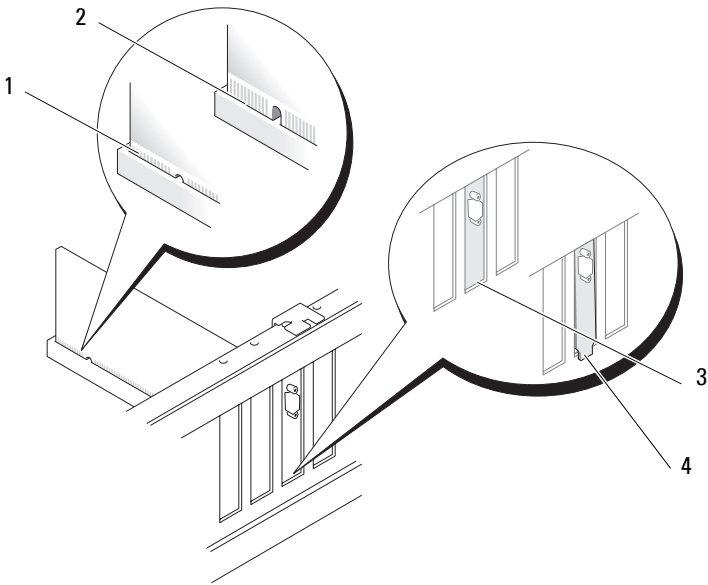

- 1 card fully seated
- 3 bracket within slot

- 2 card not fully seated
- 4 bracket caught outside of slot

11 Before you close the card retention door, ensure that:

- The tops of all cards and filler brackets are flush with the alignment bar.
- The notch in the top of the card or filler bracket fits around the alignment guide.



NOTE: For extra security, remove the alignment guide (an upside-down screw) and screw it in right side up to secure a card.

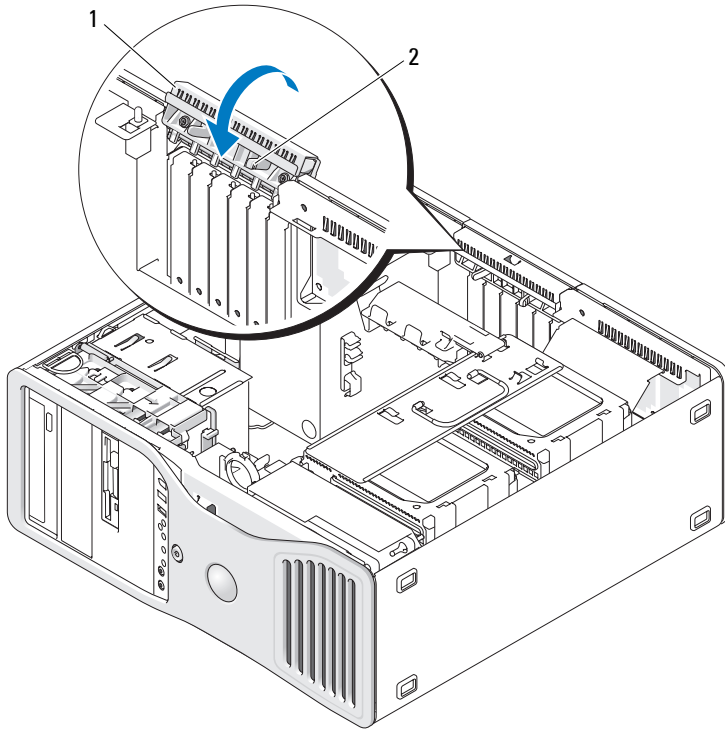

1 card retention door

2 release tab

12 Rotate the card retention door until it snaps into place.



NOTICE: Do not route card cables over or behind the cards. Cables routed over the cards can prevent the computer cover from closing properly or cause damage to the equipment.

13 Connect any cables that should be attached to the card.

See the documentation for the card for information about the card's cable connections.

14 If the card was installed in a slot close to the hard-drive carrier, check to see if there are any cables or other protrusions that might block the card retention mechanism from being lowered completely. If this is the case:

- a Pull up to free the card retention mechanism from the hard-drive carrier.
- b Find the removable card-retention device (if installed) located at the base of the card retention mechanism, beside the hard-drive carrier.
- c Grasp the removable card retention device between your thumb and forefinger and press the tip in as you pull to slide the removable device from the card-retention mechanism.

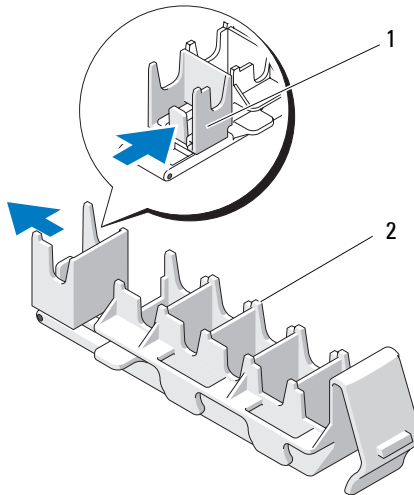

1 removable card-retention device 2 card-retention mechanism

- 15 Rotate the hard-drive carrier back into the computer (see "Rotating the Hard Drive Carrier Out of the Computer" on page 156).
- 16 Ensure that all connectors are properly cabled and firmly seated.
- ➡ **NOTICE:** To connect a network cable, first plug the cable into the network device and then plug the cable into the computer.
- 17 Replace the computer cover (see "Replacing the Computer Cover" on page 161), reconnect the computer and devices to electrical outlets, and then turn them on.
- 18 If you installed a sound card:

- a** Enter the system setup program (see "System Setup" on page 89), select **Integrated Audio**, and then change the setting to **Off**.
 - b** Connect external audio devices to the sound card's connectors. Do not connect external audio devices to the microphone, speaker/headphone, or line-in connectors on the back panel.
- 19** If you installed a network adapter card and want to disable the integrated network adapter:
 - a** Enter the system setup program (see "System Setup" on page 89), select **Integrated NIC**, and then change the setting to **Off**.
 - b** Connect the network cable to the network adapter cards connectors. Do not connect the network cable to the network connector on the back panel.
- 20** Install any drivers required for the card as described in the card documentation.

Removing an Expansion Card

- 1** Follow the procedures in "Before You Begin" on page 151.
- 2** Remove the computer cover (see "Removing the Computer Cover" on page 153).
- 3** Rotate the hard-drive carrier out of the computer (see "Rotating the Hard Drive Carrier Out of the Computer" on page 156).
- 4** Press the release tabs on the card retention door towards each other and pivot the door open.
Because the door is captive, it will remain in the open position.

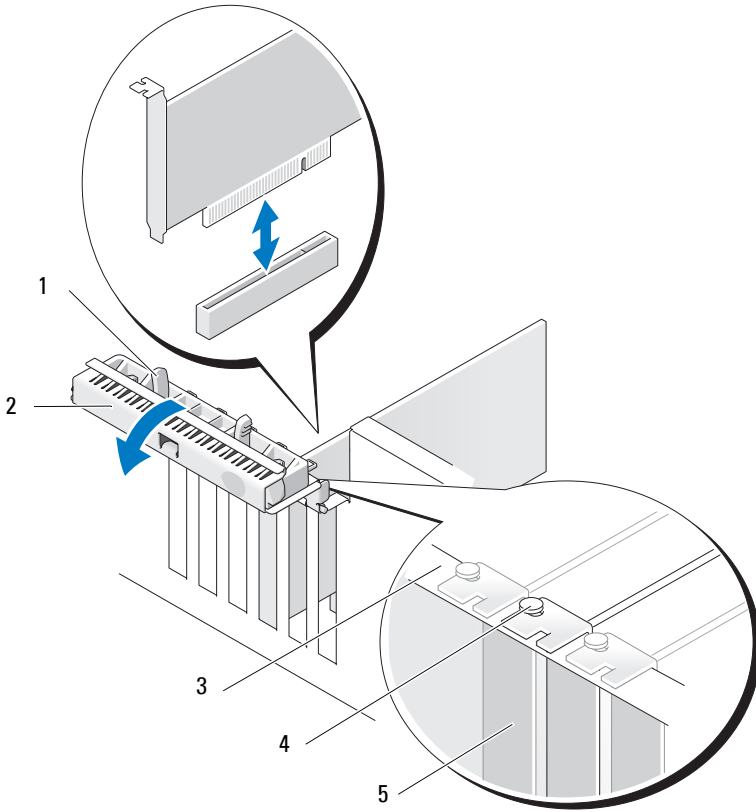

- 1 release tab
- 2 card retention door
- 3 alignment bar
- 4 alignment guide

NOTE: For extra security, remove the alignment guide (an upside-down screw) and screw it in right side up to secure a card.

- 5 filler bracket

5 Remove the card:

- a** If necessary, disconnect any cables connected to the card.

- b If the card is full-length, press the release tab on the end of the alignment guides on the fan case.
 - c If the connector has a release tab, press the release tab as you grasp the card by its top corners, and ease it out of its connector.
- 6 If you are removing the card permanently, install a filler bracket in the empty card-slot opening.



NOTE: Installing filler brackets over empty card-slot openings is necessary to maintain FCC certification of the computer. The brackets also keep dust and dirt out of your computer.

- 7 Before you close the card retention door, ensure that:
- The tops of all cards and filler brackets are flush with the alignment bar.
 - The notch in the top of each card or filler bracket fits around the alignment guide.



NOTE: For extra security, remove the alignment guide (an upside-down screw) and screw it in right side up to secure a card.

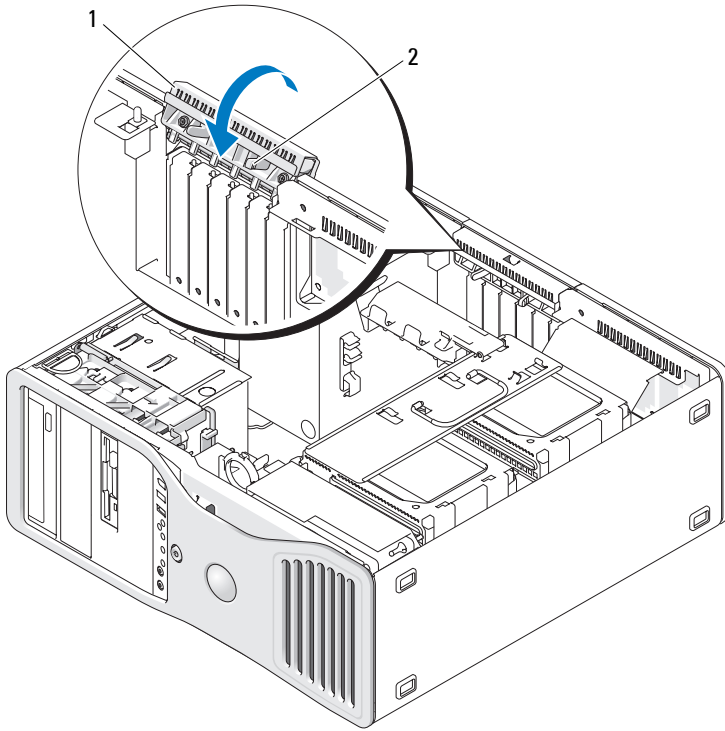

1 card retention door

2 release tab

8 Rotate the card retention door until it snaps into place.



NOTICE: Do not route card cables over or behind the cards. Cables routed over the cards can prevent the computer cover from closing properly or cause damage to the equipment.

9 Connect any cables that should be attached to the card.

See the documentation for the card for information about the card's cable connections.

10 Ensure that all connectors are properly cabled and firmly seated.

- 11 Rotate the hard-drive carrier back into place (see "Rotating the Hard Drive Carrier Out of the Computer" on page 156).
- ➡ **NOTICE:** To connect a network cable, first plug the cable into the network device and then plug the cable into the computer.
- 12 Replace the computer cover (see "Replacing the Computer Cover" on page 161), reconnect the computer and devices to electrical outlets, and then turn them on.
- 13 Uninstall the driver for the removed card. See the documentation that came with the card for special instructions.
- 14 If you removed a sound card:
 - a Enter the system setup program (see "System Setup" on page 89), select **Integrated Audio**, and then change the setting to **On**.
 - b Connect external audio devices to the audio connectors on the back panel of the computer.
- 15 If you removed a network adapter card:
 - a Enter the system setup program (see "System Setup" on page 89), select **Integrated NIC**, and then change the setting to **On**.
- 16 Connect the network cable to the network connector on the back panel of the computer.

Drives

Tower Computer Drives

Possible fully-populated computer configurations:

- Three serial ATA (SATA) or serial-attached SCSI (SAS) hard drives and up to two optical drives
- Up to two (SAS or SATA) hard drives with up to two optical drives and one floppy drive or one Media Card Reader

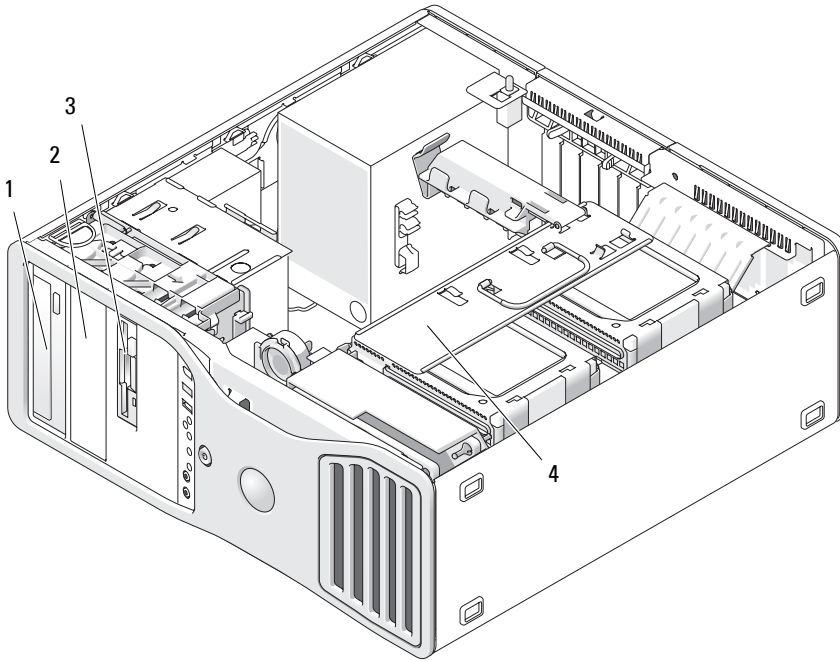

- | | | | |
|---|---|---|---|
| 1 | upper 5.25-inch drive bay (holds an optical drive) | 2 | lower 5.25-inch drive bay (holds optional optical drive) |
| 3 | FlexBay (holds optional third hard drive, floppy drive, or Media Card Reader) | 4 | rotatable hard-drive carrier (holds two SAS or SATA drives) |

Desktop Computer Drives

Possible fully-populated computer configurations:

- Up to three SATA hard drives or two (internal) SAS and one SATA hard drive, one optical drive, and one floppy drive or Media Card Reader
- Up to two hard drives, up to two optical drives, and one floppy drive or one Media Card Reader

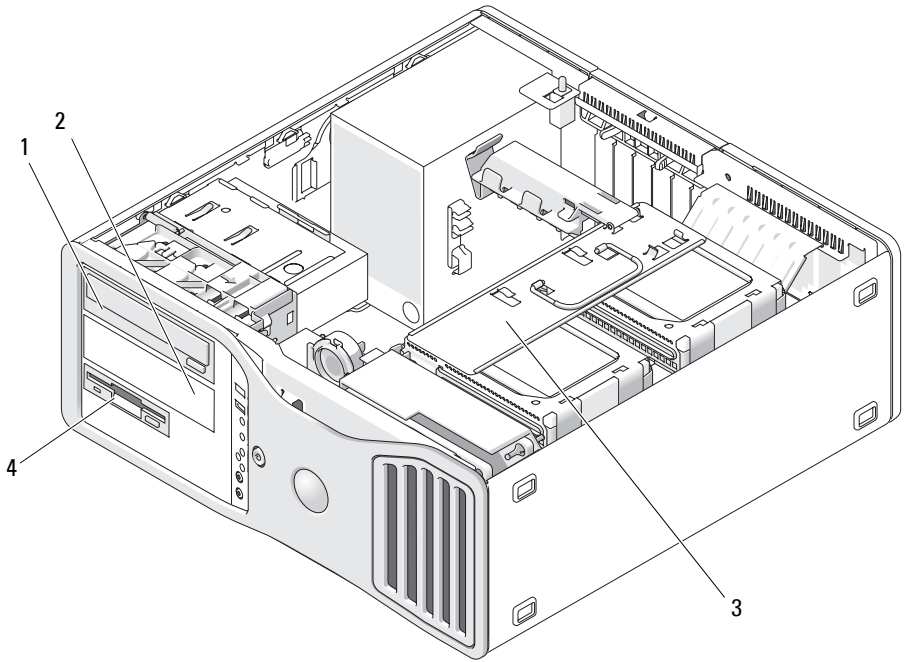

- | | | | |
|---|---|---|---|
| 1 | upper 5.25-inch drive bay (holds an optical drive) | 2 | lower 5.25-inch drive bay (holds optional optical drive or SATA hard drive) |
| 3 | rotatable hard-drive carrier (holds two SAS or SATA drives) | 4 | FlexBay (holds optional floppy drive or Media Card Reader) |

About the Metal Shields Present in Some Drive Configurations

In certain computer configurations, metal shields are present in the drive bays of your computer. If metal shields are present in your computer configuration, they are essential and must be installed in the appropriate bays at all times.



NOTICE: If metal shields are present in your computer configuration, they must be installed at all times while your computer is in use or your computer may not function properly.

Desktop Orientation

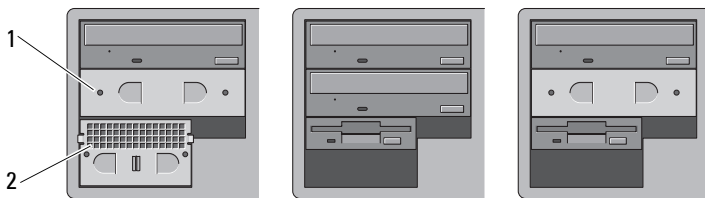

Tower Orientation

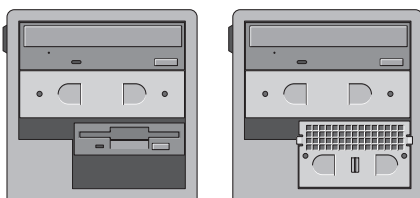

1 5.25-inch metal shield

2 vented metal insert

Note the three scenarios in which a metal shield may be removed and not immediately replaced:

- If the FlexBay held a third hard-drive (in the tower configuration only) or was empty (in either configuration) with a vented metal shield in front of it and you install a floppy drive or Media Card Reader in that bay, a shield is not needed in that bay.
- If the FlexBay held a Media Card Reader or floppy drive (in the tower configuration only) and you install a hard drive in its place, a vented metal shield must be installed in front of the hard drive in the FlexBay.
- If a metal shield is installed in the 5.25-inch drive bay and you install an optical drive in its place, a shield is not needed in that bay.

In either of the above situations, the metal shield should be kept in case it is needed later.

If you remove a floppy drive, a Media Card Reader, or an optical drive from your computer, you will need to install a metal shield in its place. If a metal shield is not installed in any of these cases, your computer may not function properly. Contact Dell if you need an extra shield (see "Contacting Dell" on page 295).

General Drive Installation Guidelines



NOTICE: If metal shields are present in your computer configuration, they must be installed at all times while your computer is in use or your computer may not function properly.

When you install a drive, you connect two cables—a DC power cable from the power supply and a data cable—to the back of the drive. The other end of the data cable will connect to either an expansion card or to the system board. Most connectors are keyed for correct insertion; that is, a notch or a missing pin on one connector matches a tab or a filled-in hole on the other connector.

Power Cable Connectors

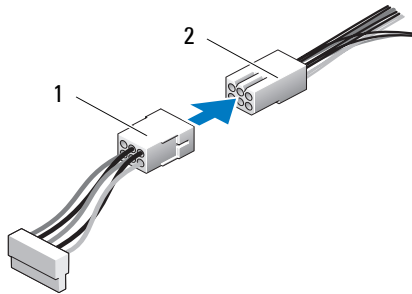

1 power cable

2 power input connector

When connecting a data cable, hold the cable by the connector at each end and press firmly into the connector. When disconnecting a data cable, hold the cable by the connector at each end and pull until the connector detaches.

SATA Data Cable Connectors

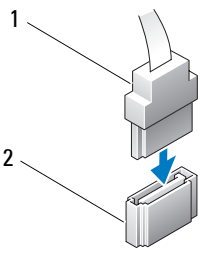

- 1 SATA data cable
- 3 SATA drive

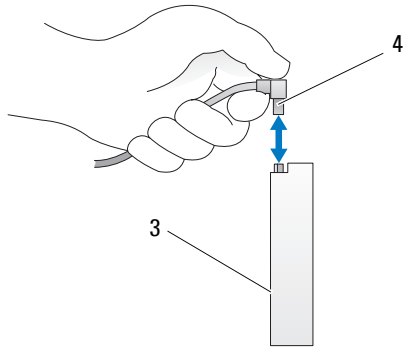

- 2 SATA connector on system board
- SATA data cable

SAS Data Cable Connectors

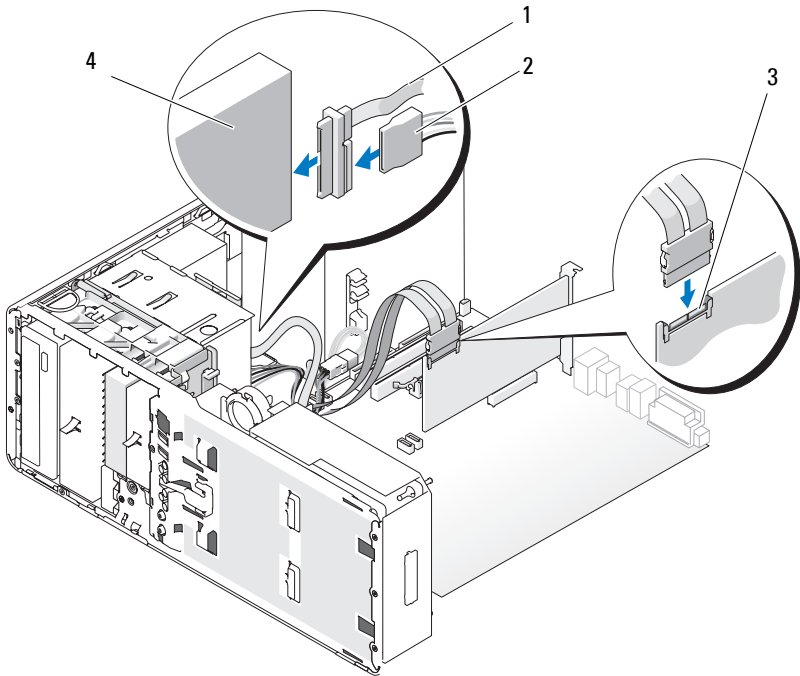

- 1 SAS data cable
- 3 SAS connector

- 2 power cable
- 4 SAS drive

Controller Card Data Cable Connectors

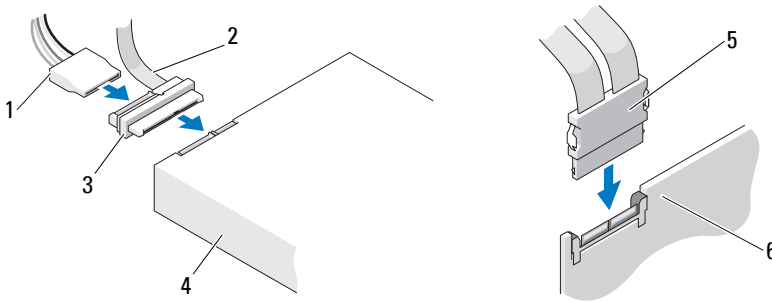

- 1 power connector
- 2 SAS data connector
- 3 interposer
- 4 SAS drive
- 5 SAS connector
- 6 optional PCI Express SAS controller card

Hard Drive

NOTICE: It is recommended that you only use SAS cables purchased from Dell. Cables purchased elsewhere are not guaranteed to work with Dell computers.

Removing a Hard Drive from the Rotatable Carrier (Tower or Desktop Computer)

- CAUTION:** Before you begin any of the procedures in this section, follow the safety instructions in the *Product Information Guide*.
- CAUTION:** To guard against electrical shock, always unplug your computer from the electrical outlet before opening the cover.
- NOTICE:** To prevent static damage to components inside your computer, discharge static electricity from your body before you touch any of your computer's electronic components. You can do so by touching an unpainted metal surface on the computer.
- NOTICE:** To avoid damage to the hard drive, do not set it on a hard surface. Instead, set the drive on a surface, such as a foam pad, that will sufficiently cushion it.

- 1 If you are replacing a hard drive that contains data that you want to keep, back up your files before you begin this procedure.
- 2 Follow the procedures in "Before You Begin" on page 151.

3 Remove the computer cover (see "Removing the Computer Cover" on page 153).

➔ NOTICE: *If only one hard drive is to be installed, it should be connected to the SATA0 connector on the system board.*

4 Disconnect the hard drive power cable from the hard drive that you are removing.

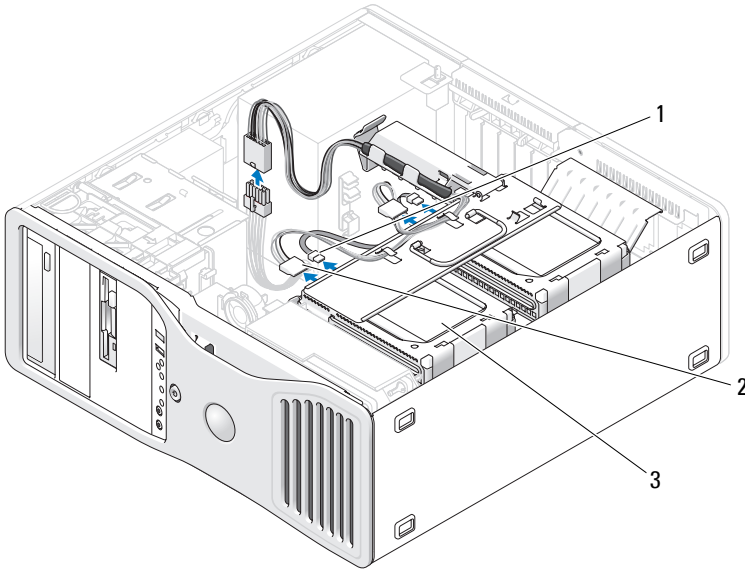

1 data connector

2 power connector

3 hard drive

5 Disconnect the data cable from the hard drive that you are removing.

Do not disconnect the data cable for an uninstalled hard drive from the system board.

6 Rotate the hard-drive carrier out of the computer (see "Rotating the Hard-Drive Carrier Back into the Computer" on page 159).

7 Press the blue tabs on each side of the hard-drive bracket toward each other and slide the drive up and out of the hard-drive bay.

If you are going to install a replacement drive, see "Installing a Hard Drive into the Rotatable Carrier (Tower or Desktop Computer)" on page 215.

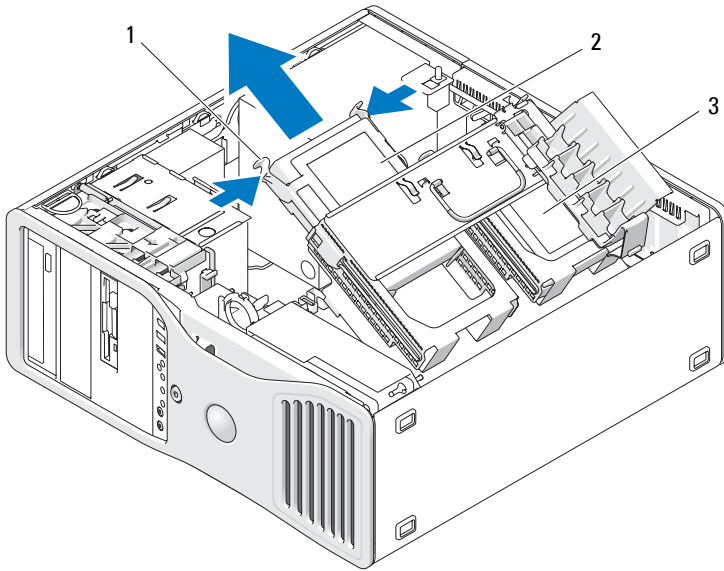

- 1 blue tabs (2)
- 2 hard drive in primary hard-drive bay
- 3 secondary hard drive bay

- 8 Ensure that all connectors are properly cabled and firmly seated.
- 9 Rotate the hard-drive carrier back into place (see "Rotating the Hard-Drive Carrier Back into the Computer" on page 159).
- 10 Replace the computer cover (see "Replacing the Computer Cover" on page 161).
- ➔ **NOTICE:** To connect a network cable, first plug the cable into the network port or device and then plug it into the computer.
- 11 Connect the computer and devices to electrical outlets, and turn them on.

Installing a Hard Drive into the Rotatable Carrier (Tower or Desktop Computer)



CAUTION: Before you begin any of the procedures in this section, follow the safety instructions in the *Product Information Guide*.



CAUTION: To guard against electrical shock, always unplug your computer from the electrical outlet before opening the cover.



NOTICE: To prevent static damage to components inside your computer, discharge static electricity from your body before you touch any of your computer's electronic components. You can do so by touching an unpainted metal surface on the computer.



NOTICE: To avoid damage to the hard drive, do not set it on a hard surface. Instead, set the drive on a surface, such as a foam pad, that will sufficiently cushion it.

- 1 If you are replacing a hard drive that contains data that you want to keep, back up your files before you begin this procedure.
- 2 Unpack the replacement hard drive, and prepare it for installation.
- 3 Check the documentation for the hard drive to verify that the drive is configured for your computer.
- 4 Follow the procedures in "Before You Begin" on page 151.
- 5 Remove the computer cover (see "Removing the Computer Cover" on page 153).
- 6 Rotate the hard-drive carrier out of the computer (see "Rotating the Hard Drive Carrier Out of the Computer" on page 156).
- 7 If you are replacing a hard drive, remove the drive that you are replacing (see "Removing a Hard Drive from the Rotatable Carrier (Tower or Desktop Computer)" on page 212).

If there is a hard-drive bracket in the empty hard-drive bay, remove the bracket by pressing its tabs toward it each other and pulling it up and out of the drive bay.

- 8 If a *replacement* hard drive does not have the hard-drive bracket attached, remove the bracket from the old drive.

Flex the hard-drive bracket open and align the side holes in the new hard drive with the plastic pins on the bracket; release the tension upon the bracket so that the hard drive is securely fastened.

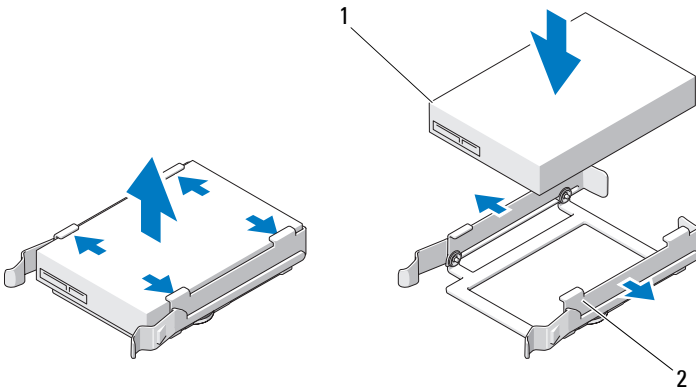

1 drive

2 hard-drive bracket

➔ NOTICE: SAS drives and SATA drives cannot be mixed in the rotatable hard-drive carrier. The drives in the hard-drive carrier must both be either SATA or SAS hard drives.

- 9 Slide the hard drive into the hard-drive bay until it clicks securely into place.
- 10 Connect a power cable to the hard drive.
- 11 If you are installing a SATA hard drive, connect the data cable to the hard drive.

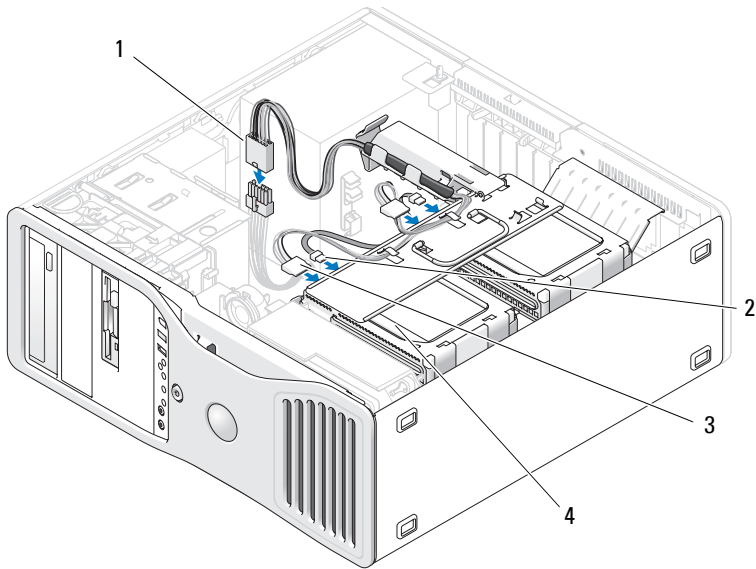

- | | | | |
|---|------------------------|---|-----------------|
| 1 | P3 power connector | 2 | SATA data cable |
| 3 | hard-drive power cable | 4 | hard drive |

➔ **NOTICE:** *If only one hard drive is to be installed, it should be connected to the SATA0 connector on the system board.*

12 Ensure that all connectors are properly cabled and firmly seated.

13 Rotate the hard-drive carrier back into place (see "Rotating the Hard-Drive Carrier Back into the Computer" on page 159).

14 Replace the computer cover (see "Replacing the Computer Cover" on page 161).

➔ **NOTICE:** To connect a network cable, first plug the cable into the network port or device and then plug it into the computer.

15 Connect the computer and devices to electrical outlets, and turn them on. See the documentation that came with the drive for instructions on installing any software required for drive operation.

 **NOTICE:** In a mixed configuration of two SAS drives and one SATA drive, the SATA drive must be the boot (primary) drive and must go in the FlexBay.

16 If the drive you just installed is the primary drive, insert bootable media into drive A.

17 Enter the system setup program (see "System Setup" on page 89), and update the appropriate **Drive** option.

18 Exit the system setup program and reboot the computer.

19 Partition and logically format your drive before you proceed to the next step.

See the documentation for your operating system for instructions.

20 Test the hard drive. See "Dell Diagnostics" on page 136 for instructions.

21 If the drive you just installed is the primary drive, install your operating system on the hard drive.

Removing an Optional Third Hard Drive (Tower Computer Only)



CAUTION: Before you begin any of the procedures in this section, follow the safety instructions in the *Product Information Guide*.



CAUTION: To guard against electrical shock, always unplug your computer from the electrical outlet before opening the cover.



NOTICE: To prevent static damage to components inside your computer, discharge static electricity from your body before you touch any of your computer's electronic components. You can do so by touching an unpainted metal surface on the computer.



NOTICE: To avoid damage to the hard drive, do not set it on a hard surface. Instead, set the drive on a surface, such as a foam pad, that will sufficiently cushion it.

1 If you are replacing a hard drive that contains data that you want to keep, back up your files before you begin this procedure.

2 Follow the procedures in "Before You Begin" on page 151.

3 Remove the computer cover (see "Removing the Computer Cover" on page 153).

4 Remove the drive panel (see "Removing the Drive Panel" on page 233).

➔ NOTICE: If metal shields are present in your computer configuration, they must be installed at all times while your computer is in use or your computer may not function properly.

- 5 If metal shields are present in your computer (see "About the Metal Shields Present in Some Drive Configurations" on page 207) slide the sliding-plate lever to the right and hold it in place as you pull to remove the vented metal insert from the FlexBay.
- 6 Disconnect the power cable from the back of the hard drive.

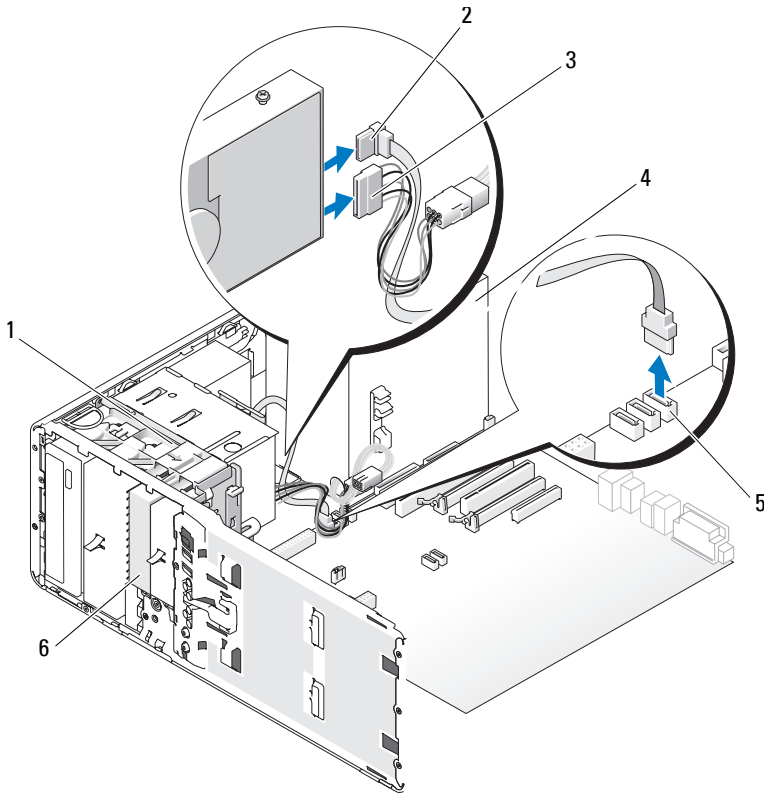

- | | | | |
|---|--------------------------------|---|-------------------------------------|
| 1 | sliding-plate lever | 2 | SATA data cable |
| 3 | power cable | 4 | power supply |
| 5 | SATA connector on system board | 6 | optional SATA hard drive in FlexBay |

- 7 Disconnect the data cable from the back of the hard drive and from the connector on the system board.

If it is connected to a card and you will not be reinstalling the drive, route the data cable to the side.

- 8 Slide the sliding-plate lever to the right to release the shoulder screw and slide the drive out of the FlexBay.

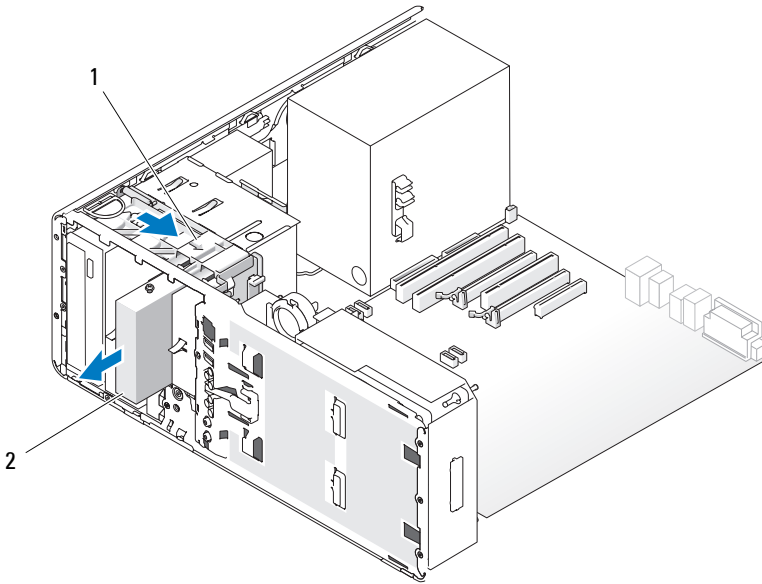

- | | | | |
|---|---------------------|---|--------------------------------------|
| 1 | sliding-plate lever | 2 | optional third hard drive in FlexBay |
|---|---------------------|---|--------------------------------------|

- 9 Set the drive aside in a secure location.



NOTICE: If metal shields are present in your computer configuration, they must be installed at all times while your computer is in use or your computer may not function properly.

- 10 If you are not installing another drive in the drive bay, and

If metal shields are present in your computer (see "About the Metal Shields Present in Some Drive Configurations" on page 207), reinstall the vented metal insert over the FlexBay and the empty space beneath it.

- a Insert the metal insert's two upper screws and its two lower screws into the corresponding slots inside the FlexBay.
- b Push the vented metal insert until it clicks into place and its metal tabs rest flush against the chassis surface.

Install a drive-panel insert (see "Replacing a Drive-Panel Insert" on page 236).

- 11 Reinstall the drive panel (see "Replacing the Drive Panel" on page 237).

- 12 Ensure that all connectors are properly cabled and firmly seated.

- 13 Replace the computer cover (see "Replacing the Computer Cover" on page 161).



NOTICE: To connect a network cable, first plug the cable into the network port or device and then plug it into the computer.

- 14 Connect the computer and devices to electrical outlets, and turn them on.

Installing an Optional Third Hard Drive (Tower Computer Only)



CAUTION: Before you begin any of the procedures in this section, follow the safety instructions in the *Product Information Guide*.



CAUTION: To guard against electrical shock, always unplug your computer from the electrical outlet before opening the cover.



NOTICE: To prevent static damage to components inside your computer, discharge static electricity from your body before you touch any of your computer's electronic components. You can do so by touching an unpainted metal surface on the computer.



NOTICE: To avoid damage to the hard drive, do not set it on a hard surface. Instead, set the drive on a surface, such as a foam pad, that will sufficiently cushion it.

- 1 If you are installing a new drive, unpack the drive and prepare it for installation.

Check the documentation for the drive to verify that it is configured for your computer.



NOTE: The screws installed in the following step must be installed in the front four screw holes in order for the drive to be installed.

- 2 Install 4 screws in the front four holes on the sides of the drive, if they are not already installed.

Otherwise, verify that the screws are installed in the front 4 holes.

- 3 Follow the procedures in "Before You Begin" on page 151.
- 4 Remove the computer cover (see "Removing the Computer Cover" on page 153).
- 5 Remove the drive panel (see "Removing the Drive Panel" on page 233).



NOTICE: If metal shields are present in your computer configuration, they must be installed at all times while your computer is in use or your computer may not function properly.

- 6 If the FlexBay is not populated and metal shields are present in your computer (see "About the Metal Shields Present in Some Drive Configurations" on page 207 for more information), slide the sliding-plate lever to the right and hold it in place as you pull to remove the vented metal insert from the FlexBay.
- 7 If you already have a *floppy drive* or *Media Card Reader* installed in the FlexBay, remove it (see "Removing a Floppy Drive (Tower Computer)" on page 240 or "Removing a Media Card Reader (Tower Computer)" on page 254).
- 8 If you already have a *hard drive* installed in the FlexBay, remove the hard drive (see "Removing an Optional Third Hard Drive (Tower Computer Only)" on page 218).
- 9 Gently slide the drive into place in the FlexBay; the drive clicks through two notches before it is securely installed.

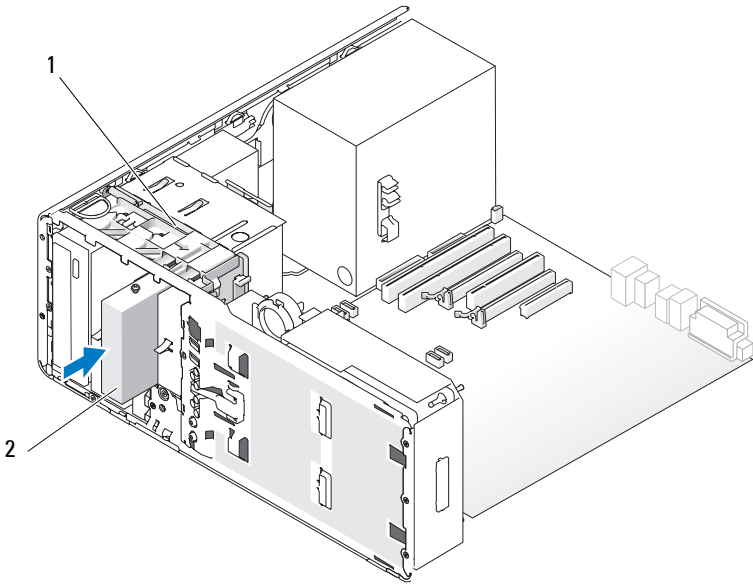

- 1 sliding-plate lever 2 optional third hard drive in FlexBay

- 10** Connect a power cable to the back of the hard drive.
- 11** Connect a data cable to the back of the hard drive and, if it is a SATA drive, connect the other end to the SATA_2 connector on the system board.

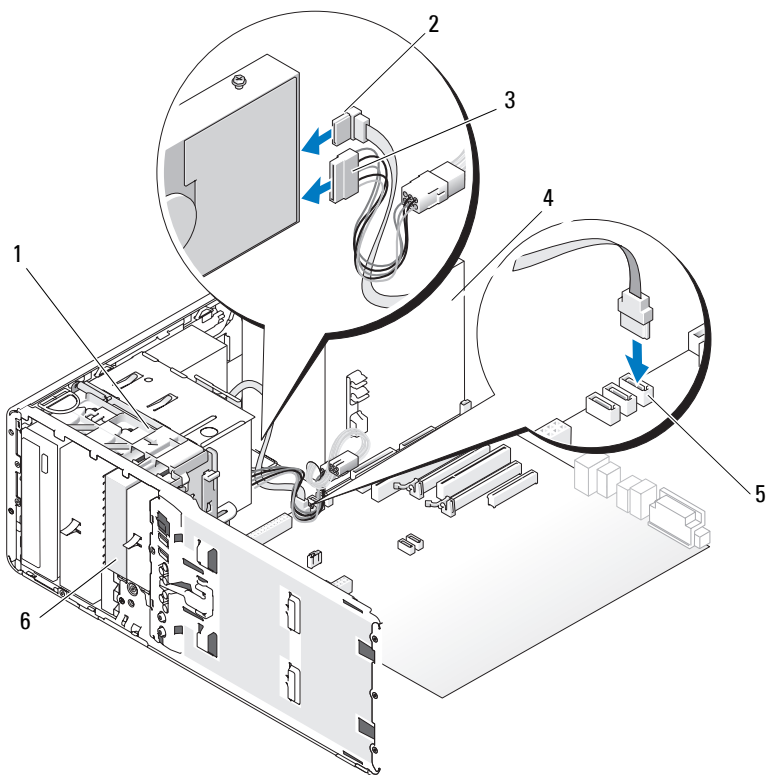

- | | | | |
|---|--------------------------------|---|---|
| 1 | sliding-plate lever | 2 | SATA data cable |
| 3 | power cable | 4 | power supply |
| 5 | SATA connector on system board | 6 | optional SATA hard drive in FlexBay board |



NOTICE: If metal shields are present in your computer configuration, they must be installed at all times while your computer is in use or your computer may not function properly.

- 12** If metal shields are present in your computer, install the vented metal insert over the FlexBay and the empty space beneath it (see "About the Metal Shields Present in Some Drive Configurations" on page 207 for more information):

- a Insert the metal insert's two upper screws and its two lower screws into the corresponding slots inside the FlexBay.
 - b Push the vented metal insert until it clicks into place and its metal tabs rest flush against the chassis surface.
- 13 Reinstall the drive panel (see "Replacing the Drive Panel" on page 237).
- 14 Ensure that all connectors are properly cabled and firmly seated.
- 15 Replace the computer cover (see "Replacing the Computer Cover" on page 161).
-  **NOTICE:** To connect a network cable, first plug the cable into the network port or device and then plug it into the computer.
- 16 Connect the computer and devices to electrical outlets, and turn them on. See the documentation that came with the drive for instructions on installing any software required for drive operation.
- 17 If the drive you just installed is the primary drive, insert bootable media into drive A.
- 18 Turn on the computer.
- 19 Enter the system setup program (see "System Setup" on page 89) and update the appropriate **Drive** option.
- 20 Exit the system setup program, and reboot the computer.
- 21 Partition and logically format your drive before you proceed to the next step.
See the documentation for your operating system for instructions.
- 22 Test the hard drive. See "Dell Diagnostics" on page 136 for instructions.
- 23 If the drive you just installed is the primary drive, install your operating system on the hard drive.

Removing an Optional SATA Third Hard Drive (Desktop Computer Only)



CAUTION: Before you begin any of the procedures in this section, follow the safety instructions located in the *Product Information Guide*.



CAUTION: To guard against electrical shock, always unplug your computer from the electrical outlet before removing the cover.

- 1 Follow the procedures in "Before You Begin" on page 151.

- 2 Remove the computer cover (see "Removing the Computer Cover and Front Panel" on page 153).
- 3 Remove the drive panel (see "Removing the Drive Panel" on page 233).
- 4 Pull the desktop drive retention insert out by the handle and set it aside in a safe place.

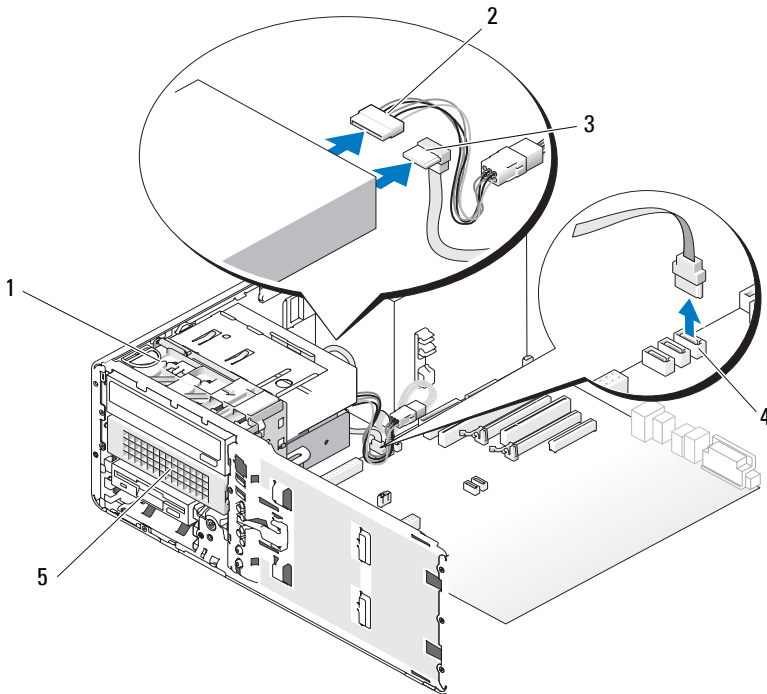

- | | | | |
|---|--|---|--------------------------------|
| 1 | desktop drive retention insert | 2 | power cable |
| 3 | SATA data cable | 4 | SATA connector on system board |
| 5 | optional third SATA hard drive in hard-drive carrier | | |

- 5 Disconnect the power cable from the back of the hard drive.

- 6 Disconnect the data cable from the back of the hard drive and from the connector on the system board.
- 7 Slide the hard-drive carrier out of the 5.25-inch drive bay.

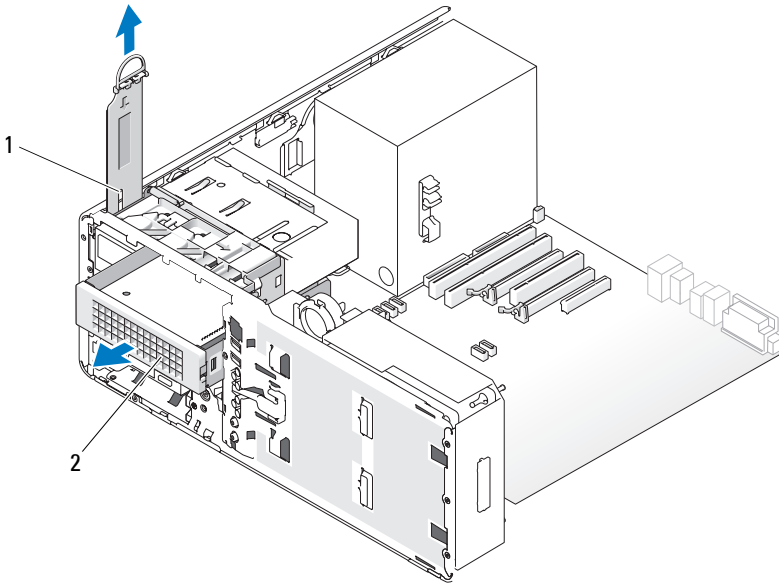

- 1 desktop drive retention insert 2 optional third SATA hard drive in hard-drive carrier

- 8 Press the blue tabs on each side of the hard-drive bracket toward each other and slide the drive out of the hard-drive carrier.
- 9 Set the drive and carrier aside in a secure location.
- 10 Ensure that all connectors are properly cabled and firmly seated.
- 11 **NOTICE:** If metal shields are present in your computer configuration, they must be installed at all times while your computer is in use or your computer may not function properly.
- 11 If you are not installing another drive in the drive bay, install a drive-panel insert (see "Replacing a Drive-Panel Insert" on page 236).

Then, if metal shields are present in your computer (see "About the Metal Shields Present in Some Drive Configurations" on page 207), install the 5.25-inch metal shield in its place: align its screws in the metal rails and push the shield back until it clicks into place.

- 12 If you are installing another drive in the optical drive bay, see the appropriate procedure.
 - 13 Replace the desktop drive retention insert and fold down its handle.
 - 14 Reinstall the drive panel (see "Replacing the Drive Panel" on page 237).
 - 15 Replace the computer cover (see "Replacing the Computer Cover" on page 161).
-  **NOTICE:** To connect a network cable, first plug the cable into the network port or device and then plug it into the computer.
- 16 Connect the computer and devices to electrical outlets, and turn them on.

Installing an Optional Third SATA Hard Drive (Desktop Only)



CAUTION: Before you begin any of the procedures in this section, follow the safety instructions located in the *Product Information Guide*.



CAUTION: To guard against electrical shock, always unplug your computer from the electrical outlet before removing the cover.



NOTICE: In order to install a third SATA hard drive in one of the 5.25-inch drive bays, it must be installed in the provided hard-drive carrier, then installed into the lower 5.25-inch drive bay.

- 1 If you are installing a new drive, unpack the drive and prepare it for installation.
Check the documentation for the drive to verify that it is configured for your computer.
- 2 Follow the procedures in "Before You Begin" on page 151.
- 3 Remove the computer cover (see "Removing the Computer Cover" on page 153).
- 4 Remove the drive panel (see "Removing the Drive Panel" on page 233).
- 5 Pull the desktop drive retention insert out by the handle and set it aside in a safe place.

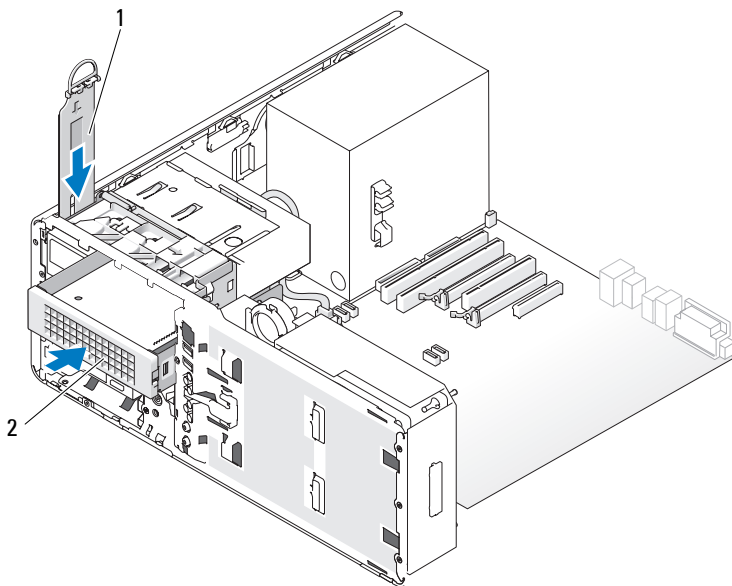

1 desktop drive-retention insert

2 optional third SATA hard drive in hard-drive carrier

- 6 If another device is installed in the optical drive bay, remove that device (see "Removing an Optical Drive (Desktop Computer)" on page 274).

NOTICE: If metal shields are present in your computer configuration, they must be installed at all times while your computer is in use or your computer may not function properly.

- 7 If the optical drive bay is unpopulated and metal shields are present in your computer (see "About the Metal Shields Present in Some Drive Configurations" on page 207), pull to remove the 5.25-inch metal shield.

Then, remove the drive-panel insert from a 5.25-inch drive bay (see "Removing a Drive-Panel Insert" on page 235).

- 8 Flex the hard-drive bracket open and align the side holes in the hard drive with the plastic pins on the bracket; release the tension upon the bracket so that the hard drive is securely fastened.

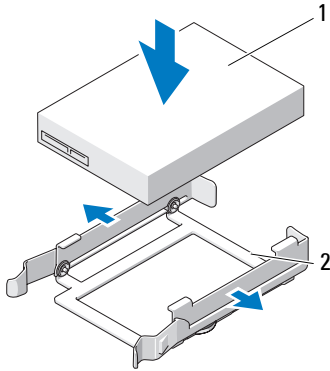

1 hard drive

2 hard-drive bracket

- 9 Slide the hard drive in the hard-drive bracket into the hard-drive carrier.

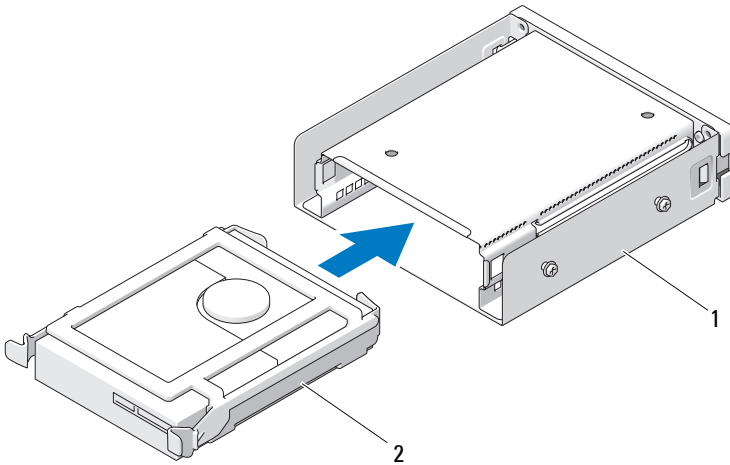

1 hard-drive carrier

2 SATA hard drive in hard-drive bracket

- 10 Slide the hard-drive carrier into the 5.25-inch drive bay until it is securely seated.

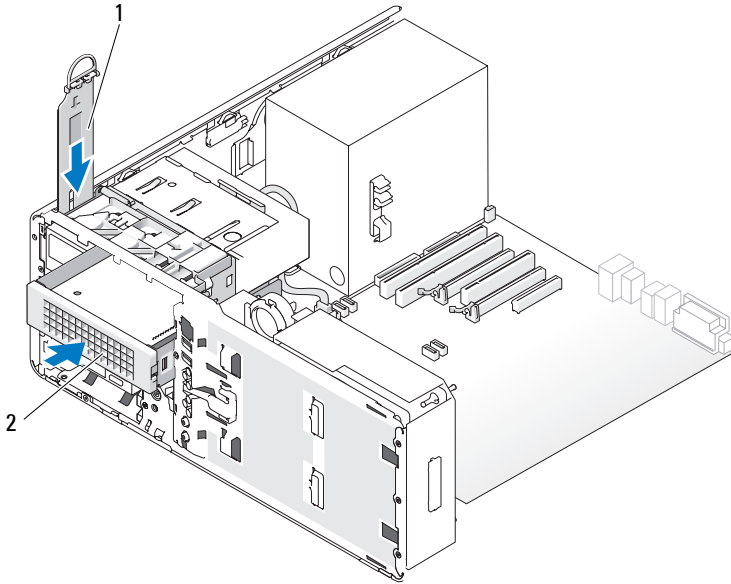

1 desktop drive-retention insert

2 optional third SATA hard drive in hard-drive carrier

11 Replace the desktop drive retention insert and fold down its handle.

12 Connect a power cable to the hard drive.

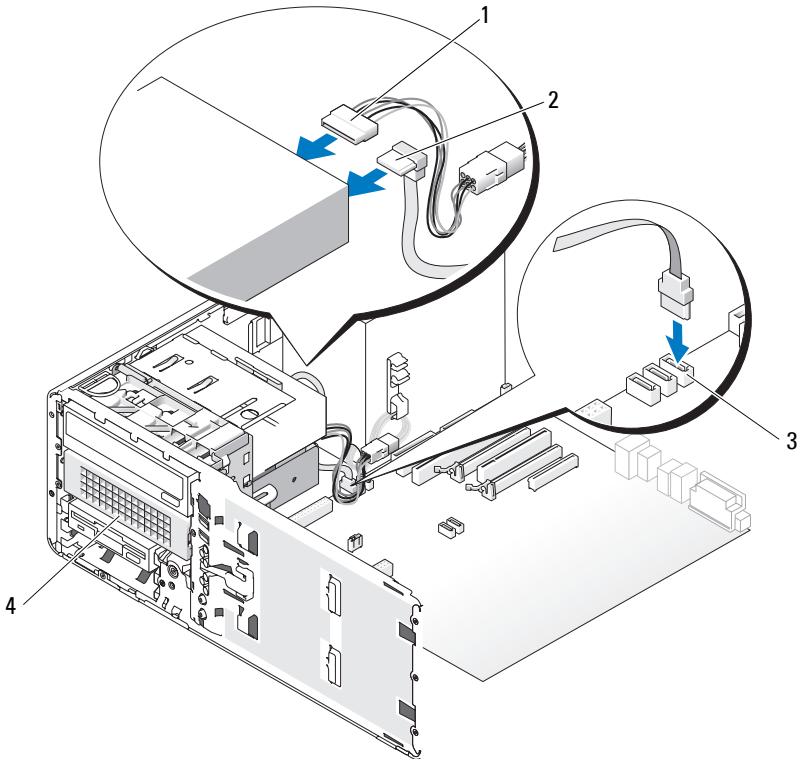



- | | | | |
|---|--------------------------------|---|--|
| 1 | power cable | 2 | SATA data cable |
| 3 | SATA connector on system board | 4 | optional third SATA hard drive in hard-drive carrier |

- 13** Connect the data cable to the back of the drive and to the connector on the system board.
- 14** Ensure that all connectors are properly cabled and firmly seated.
- 15** Reinstall the drive panel (see "Replacing the Drive Panel" on page 237).
- 16** Replace the computer cover (see "Replacing the Computer Cover" on page 161).

-  **NOTICE:** To connect a network cable, first plug the cable into the network port or device and then plug it into the computer.
- 17 Connect the computer and devices to electrical outlets, and turn them on. See the documentation that came with the drive for instructions on installing any software required for drive operation.
 - 18 If the drive you just installed is the primary drive, insert bootable media into drive A.
 - 19 Turn on the computer.
 - 20 Enter the system setup program (see "System Setup" on page 89) and update the appropriate **Drive** option.
 - 21 Exit system setup, and reboot the computer.
 - 22 Partition and logically format your drive before you proceed to the next step.
 - 23 See the documentation for your operating system for instructions.

Drive Panels

-  **CAUTION:** Before you begin any of the procedures in this section, follow the safety instructions located in the *Product Information Guide*.
-  **CAUTION:** To guard against electrical shock, always unplug your computer from the electrical outlet before removing the cover.

Removing the Drive Panel

- 1 Follow the procedures in "Before You Begin" on page 151.
- 2 Remove the front panel (see "Removing the Front Panel" on page 155).
- 3 Grasp the sliding plate lever and push it towards the base of the computer until the drive panel snaps open.

Tower Orientation

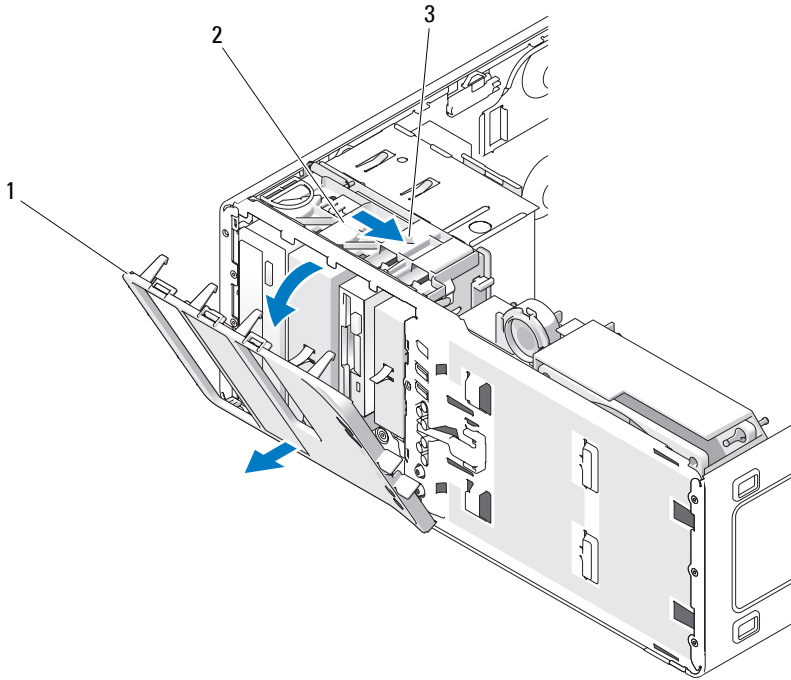

1 drive panel

2 sliding plate

3 sliding plate lever

Desktop Orientation

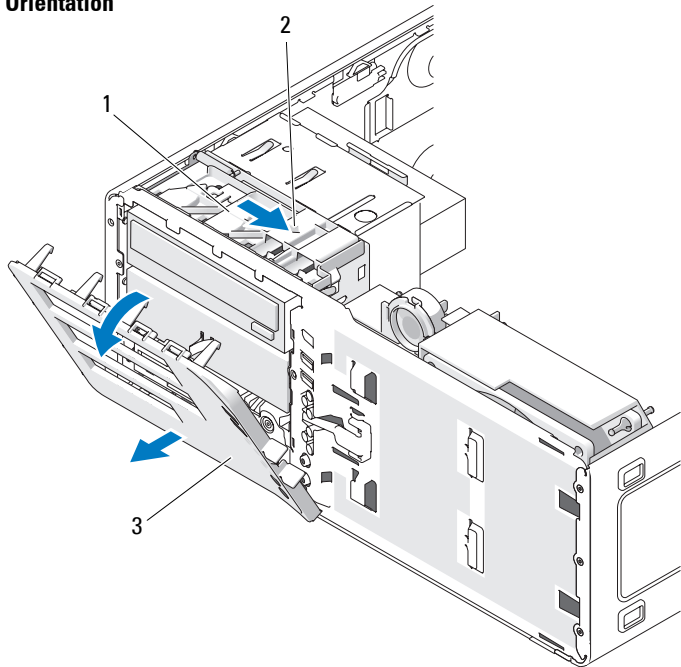

- 1 sliding plate
- 3 drive panel

- 2 sliding plate lever

- 4 Pivot the drive panel outward and lift it from its side hinges.
- 5 Set the drive panel aside in a secure location.

Removing a Drive-Panel Insert

➡ NOTICE: Drive-panel inserts may contain screws on the inside. You can attach the screws to new drives that do not have any screws.

- 1 Follow the procedures in "Before You Begin" on page 151.
- 2 Remove the computer cover (see "Removing the Computer Cover" on page 153).
- 3 Remove the drive panel (see "Removing the Drive Panel" on page 233).

➔ NOTICE: To avoid breaking the drive-panel insert tab, do not pull the insert more than approximately 1 cm (½ inch) away from the drive panel before sliding the tab out of the slot.

- 4 Pinch the drive-panel insert release tabs and rotate the insert just enough to free the release tabs.

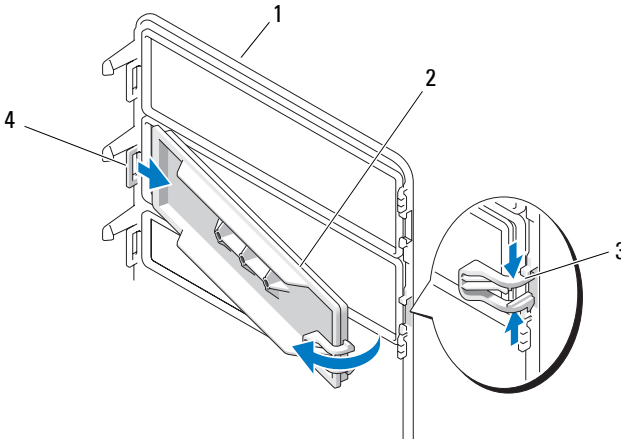

- | | |
|---------------------------------------|--------------------------------------|
| 1 drive panel | 2 drive-panel insert |
| 3 drive-panel insert release tabs (2) | 4 drive-panel insert tab in tab slot |

- 5 Slide the drive-panel insert tab out from the tab slot
- 6 Set the drive-panel insert aside in a secure location.

Replacing a Drive-Panel Insert

- 1 Slide the drive-panel insert tab into the drive-panel slot.

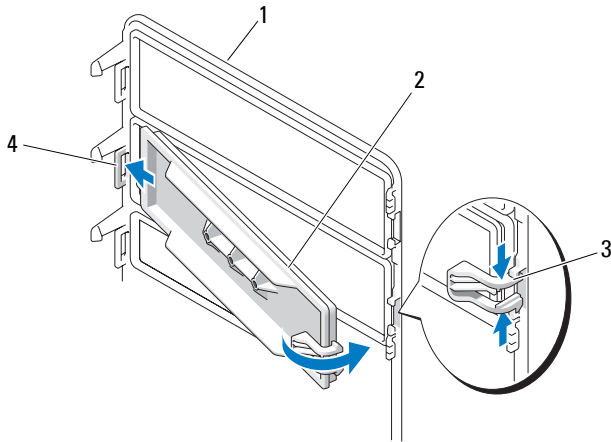

- | | | | |
|---|-------------------------------------|---|------------------------------------|
| 1 | drive panel | 2 | drive-panel insert |
| 3 | drive-panel insert release tabs (2) | 4 | drive-panel insert tab in tab slot |

- 2 Pinch the drive-panel insert release tabs together and rotate the drive-panel insert into place.
- 3 Ensure that the drive-panel insert is correctly seated in the drive panel.

Replacing the Drive Panel

- 1 Follow the procedures in "Before You Begin" on page 151.

Tower Orientation

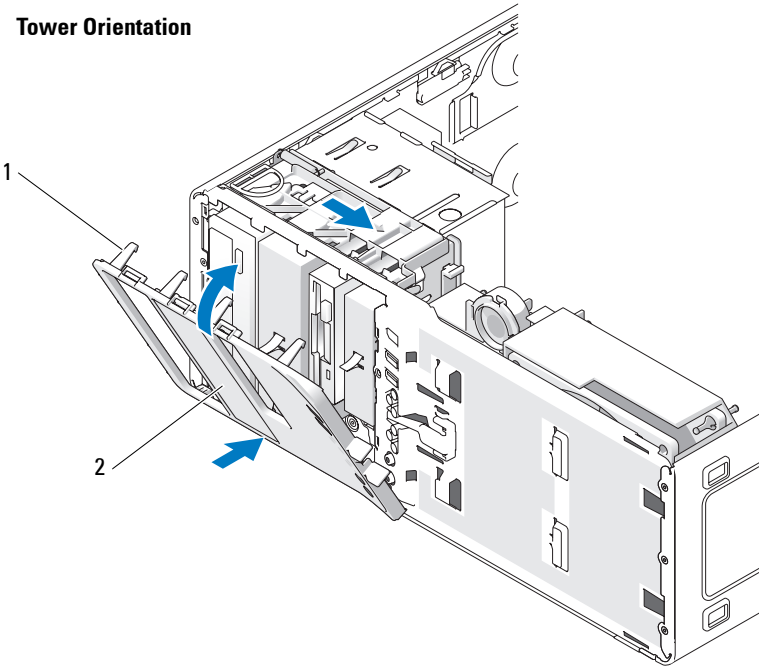

1 drive-panel tabs

2 drive panel

Desktop Orientation

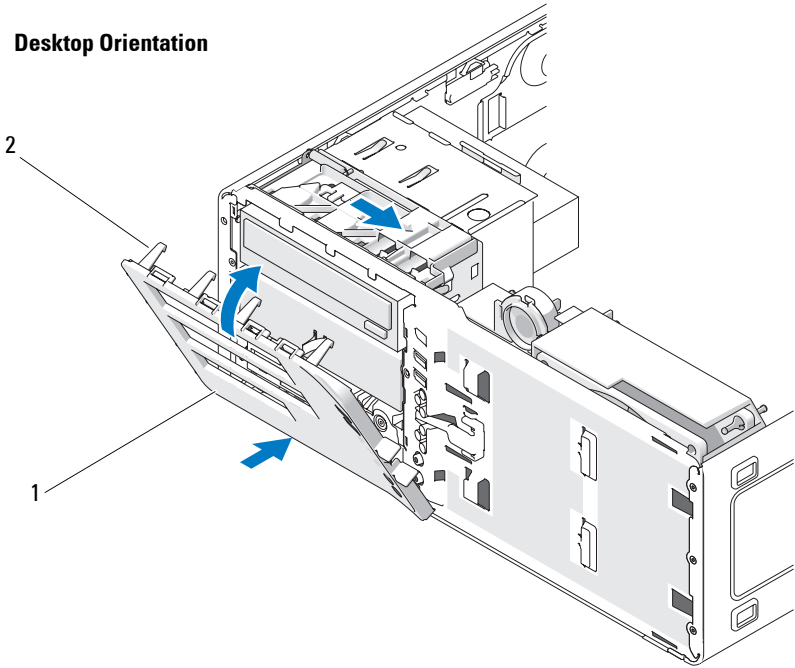

1 drive panel

2 drive-panel tabs

- 2 Align the drive panel tabs with the side-door hinges.
- 3 Rotate the drive panel toward the computer until it snaps into place on the drive panel.
- 4 Replace the front panel (see "Replacing the Front Panel" on page 160).
- 5 Replace the computer cover (see "Replacing the Computer Cover" on page 161).

Floppy Drive



CAUTION: Before you begin any of the procedures in this section, follow the safety instructions in the *Product Information Guide*.



CAUTION: To guard against electrical shock, always unplug your computer from the electrical outlet before opening the cover.



NOTICE: To prevent static damage to components inside your computer, discharge static electricity from your body before you touch any of your computer's electronic components. You can do so by touching an unpainted metal surface on the computer.



NOTE: If you are adding a floppy drive to your *tower* computer, see "Installing a Floppy Drive (Tower Computer)" on page 243.



NOTE: If you are adding a floppy drive to your *desktop* computer, see "Installing a Floppy Drive (Desktop Computer)" on page 250.

Removing a Floppy Drive (Tower Computer)

- 1 Follow the procedures in "Before You Begin" on page 151.
- 2 Remove the computer cover (see "Removing the Computer Cover" on page 153).
- 3 Remove the drive panel (see "Removing the Drive Panel" on page 233).
- 4 Disconnect the power and data cables from the back of the floppy drive.
- 5 Disconnect the other end of the drive cable from the system board connector labeled "DSKT." To locate system board connectors, see "System Board Components" on page 28.

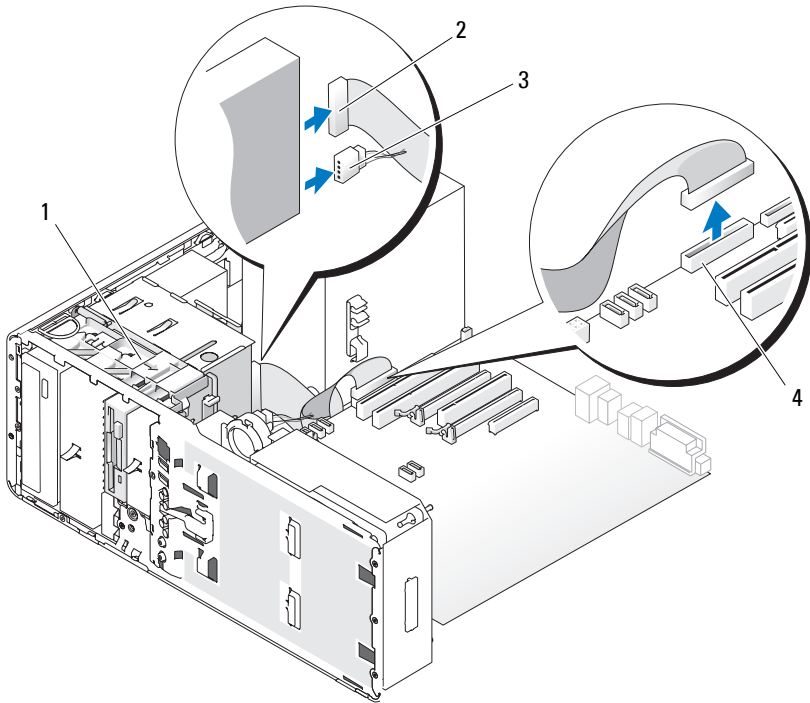

1 sliding-plate lever

2 data cable

3 power cable

4 floppy-drive connector (DSKT on system board)

- 6** Slide the sliding-plate lever to the right to release the shoulder screw and slide the drive out of the FlexBay.

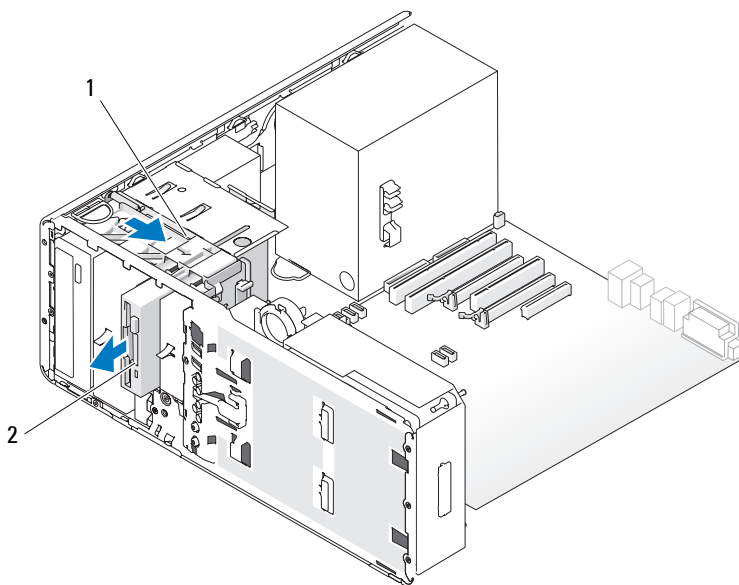

1 sliding-plate lever

2 floppy drive



NOTICE: If metal shields are present in your computer configuration, they must be installed at all times while your computer is in use or your computer may not function properly.



- 7 If you are not installing another drive in the FlexBay and metal shields are present in your computer (see "About the Metal Shields Present in Some Drive Configurations" on page 207), install the vented metal insert over the FlexBay and the empty space beneath it:
 - a Insert the metal insert's two upper screws and its two lower screws into the corresponding slots inside the FlexBay.
 - b Push the vented metal insert until it clicks into place and its metal tabs rest flush against the chassis surface.

Install a drive-panel insert (see "Replacing a Drive-Panel Insert" on page 236).

- 8 If you are installing another drive in the FlexBay, see the appropriate installation procedure in this section.

- 9 Reinstall the drive panel (see "Replacing the Drive Panel" on page 237).
 - 10 Ensure that all connectors are properly cabled and firmly seated.
 - 11 Replace the computer cover (see "Replacing the Computer Cover" on page 161).
-  **NOTICE:** To connect a network cable, first plug the cable into the network port or device and then plug it into the computer.
- 12 Connect the computer and devices to electrical outlets, and turn them on.

Installing a Floppy Drive (Tower Computer)

-  **NOTICE:** In a tower configuration with 3 hard drives, a floppy drive is not supported, since the third hard drive is installed in the FlexBay.
- 1 Follow the procedures in "Before You Begin" on page 151.
 - 2 Remove the computer cover (see "Removing the Computer Cover" on page 153).
 - 3 Remove the drive panel (see "Removing the Drive Panel" on page 233).
 - 4 If another device is installed in the FlexBay, remove that device (see the appropriate removal instructions in this section).
-  **NOTICE:** If metal shields are present in your computer configuration, they must be installed at all times while your computer is in use or your computer may not function properly.
- 5 If metal shields are present in your computer (see "About the Metal Shields Present in Some Drive Configurations" on page 207) and the FlexBay is not populated, slide the sliding-plate lever to the right and hold it in place as you pull to remove the vented metal insert from the FlexBay.
 - 6 Remove the FlexBay drive-panel insert (see "Removing a Drive-Panel Insert" on page 235).
 - 7 If no screws are attached to the drive, remove the shoulder screws from the inside of the drive panel and attach the screws to the new drive.

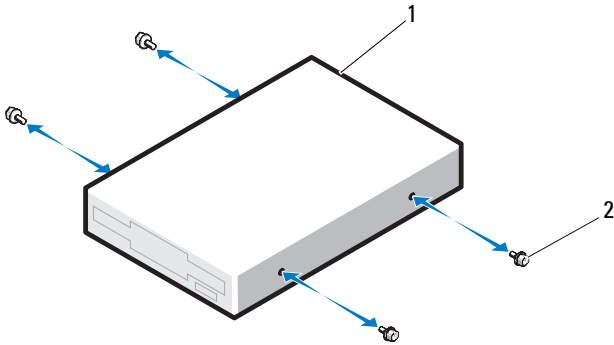

1 floppy drive 2 screws (4)

- 8** Gently slide the drive into the FlexBay until you hear a click or feel the drive securely installed.

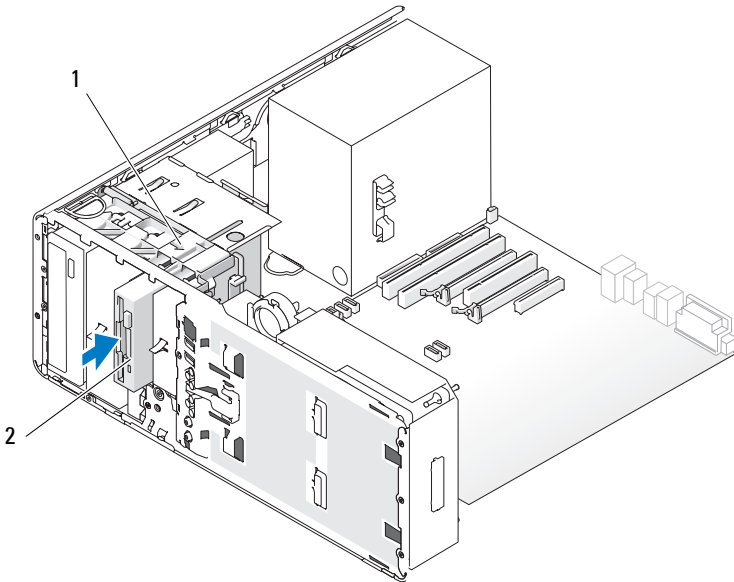

- 1 sliding-plate lever 2 floppy drive

- 9** Attach the power and data cables to the floppy drive.
- 10** Connect the other end of the data cable to the system board connector labeled "DSKT." To locate the system board connector, see "System Board Components" on page 28.

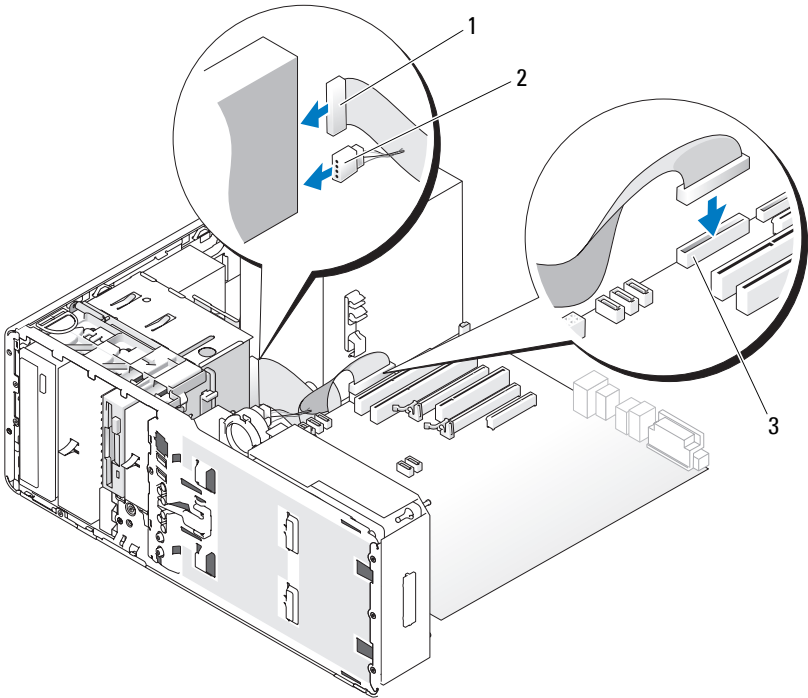

- 1 data cable 2 power cable
- 3 floppy-drive system board connector (DSKT on system board)

- 11** Check all cable connections, and fold cables out of the way to allow for airflow between the fan and cooling vents.

- 12 Reinstall the drive panel (see "Replacing the Drive Panel" on page 237).
- 13 Ensure that all connectors are properly cabled and firmly seated.
- 14 Replace the computer cover (see "Replacing the Computer Cover" on page 161).
-  **NOTICE:** To connect a network cable, first plug the cable in to the network port or device and then plug it in to the computer.
- 15 Connect your computer and devices to their electrical outlets, and turn them on.
See the documentation that came with the drive for instructions on installing any software required for drive operation.
- 16 Enter the system setup program (see "System Setup" on page 89) and select the appropriate **Diskette Drive** option.
- 17 Verify that your computer works correctly by running the Dell Diagnostics. See "Dell Diagnostics" on page 136.

Removing a Floppy Drive (Desktop Computer)

- 1 Follow the procedures in "Before You Begin" on page 151.
- 2 Remove the computer cover (see "Removing the Computer Cover" on page 153).
- 3 Remove the drive panel (see "Removing the Drive Panel" on page 233).
- 4 Disconnect the power and data cables from the back of the floppy drive.
- 5 Disconnect the other end of the drive cable from the system board connector labeled "DSKT." To locate system board connectors, see "System Board Components" on page 28.

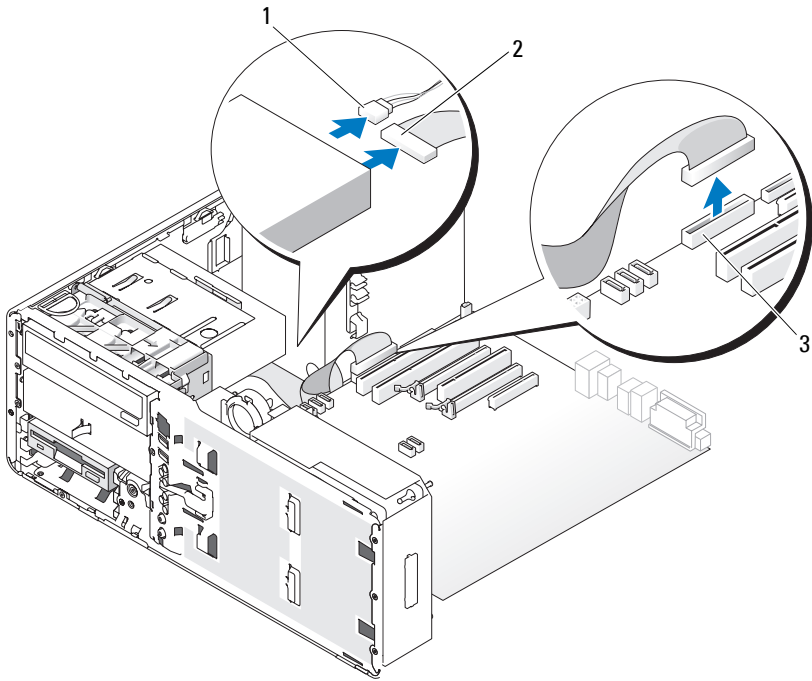

- 1 power cable
- 2 data cable
- 3 floppy-drive connector (DSKT on system board)

6 Pull the desktop drive retention insert by the handle and set it aside in a safe place.

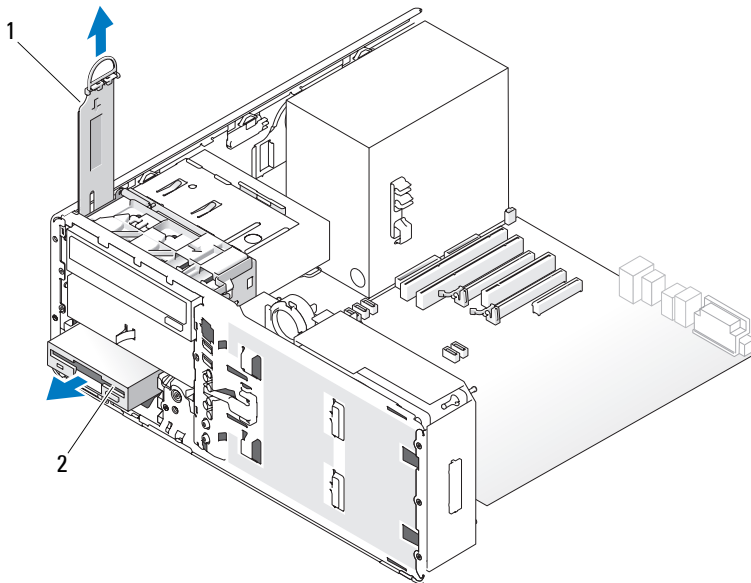

1 drive retention insert

2 floppy drive

- 7 Remove the floppy drive from the FlexBay.
- 8 If you are not installing another drive in the FlexBay, and metal shields are present in your computer (see "About the Metal Shields Present in Some Drive Configurations" on page 207), install the vented metal insert over the FlexBay and the empty space beneath it:
 - a Holding the metal insert at an angle, insert its two upper screws into the slot that runs along the inside of the FlexBay.
 - b Rotate the bottom of the vented metal insert down and insert its two bottom screws into the slot in the open area beneath the FlexBay.
 - c Push the vented metal insert until it clicks into place and its metal tabs rest flush against the chassis surface.

Then, install a drive-panel insert (see "Replacing a Drive-Panel Insert" on page 236).

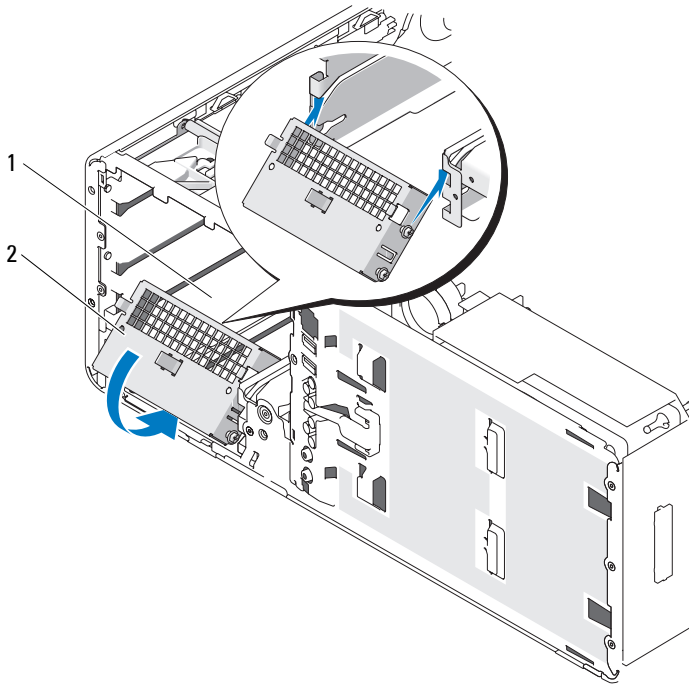

1 FlexBay

2 vented metal insert

- 9 If you are installing another drive in the FlexBay, see the appropriate installation instructions in this section.
- 10 Replace the desktop drive retention insert and fold down its handle.
- 11 Reinstall the drive panel (see "Replacing the Drive Panel" on page 237).
- 12 Ensure that all connectors are properly cabled and firmly seated.
- 13 Replace the computer cover (see "Replacing the Computer Cover" on page 161).
-  **NOTICE:** To connect a network cable, first plug the cable into the network port or device and then plug it into the computer.
- 14 Connect the computer and devices to electrical outlets, and turn them on.

Installing a Floppy Drive (Desktop Computer)

- 1 Follow the procedures in "Before You Begin" on page 151.
- 2 Remove the computer cover (see "Removing the Computer Cover" on page 153).
- 3 Remove the drive panel (see "Removing the Drive Panel" on page 233).
- 4 Pull the desktop drive retention insert by the handle and set it aside in a safe place.

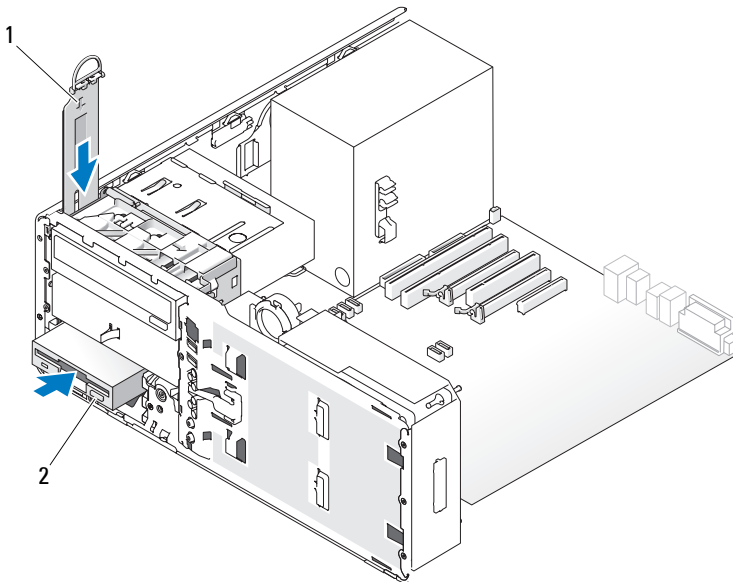

1 drive retention insert

2 floppy drive

- 5 If another device is installed in the FlexBay, remove that device (see the appropriate removal instructions in this section).



NOTICE: If metal shields are present in your computer configuration, they must be installed at all times while your computer is in use or your computer may not function properly.

- 6** If the FlexBay is not populated and metal shields are present in your computer (see "About the Metal Shields Present in Some Drive Configurations" on page 207), remove the vented metal insert:
- a** Pull the vented metal insert forward until its surface is flush with that of the surrounding chassis.
 - b** Rotate the bottom of the metal insert up towards you, disengaging its lower screws from the surrounding metal.
 - c** Lift the metal insert from the computer, disengaging its top screws and metal tabs from the surrounding metal.

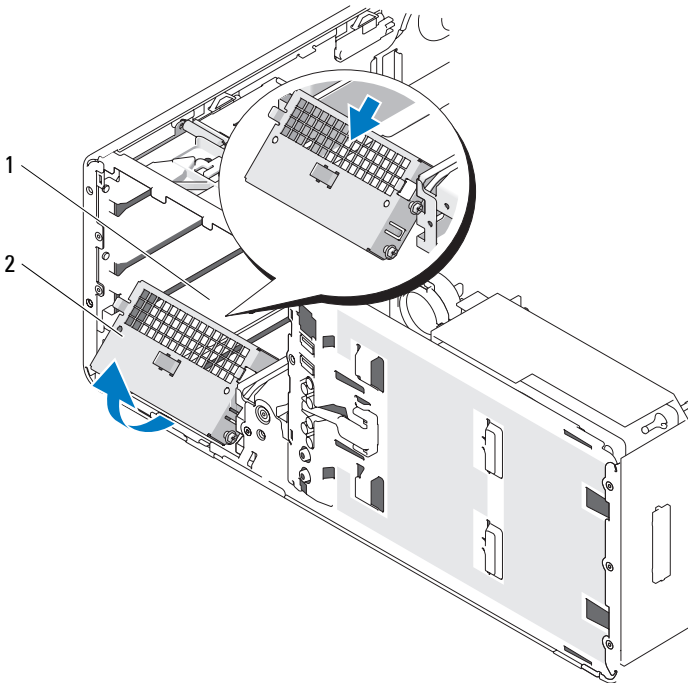

1 FlexBay

2 vented metal insert

- 7** Remove the FlexBay drive-panel insert (see "Removing a Drive-Panel Insert" on page 235).

- 8 If no screws are attached to the drive, remove the shoulder screws from the inside of the drive panel and attach the screws to the new drive.

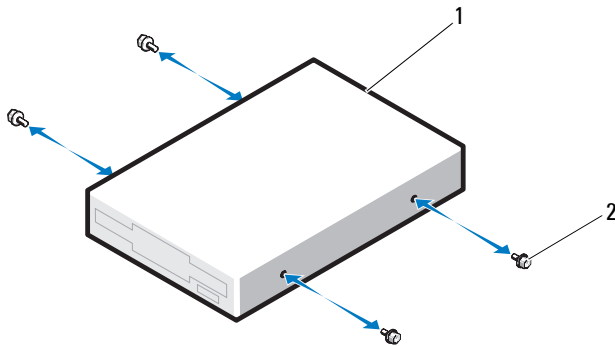

1 drive

2 screws

- 9 Gently slide the drive into the FlexBay until you hear a click or feel the drive securely installed.
- 10 Attach the power and data cables to the floppy drive.
- 11 Connect the other end of the data cable to the system board connector labeled "DSKT." To locate the system board connector, see "System Board Components" on page 28.

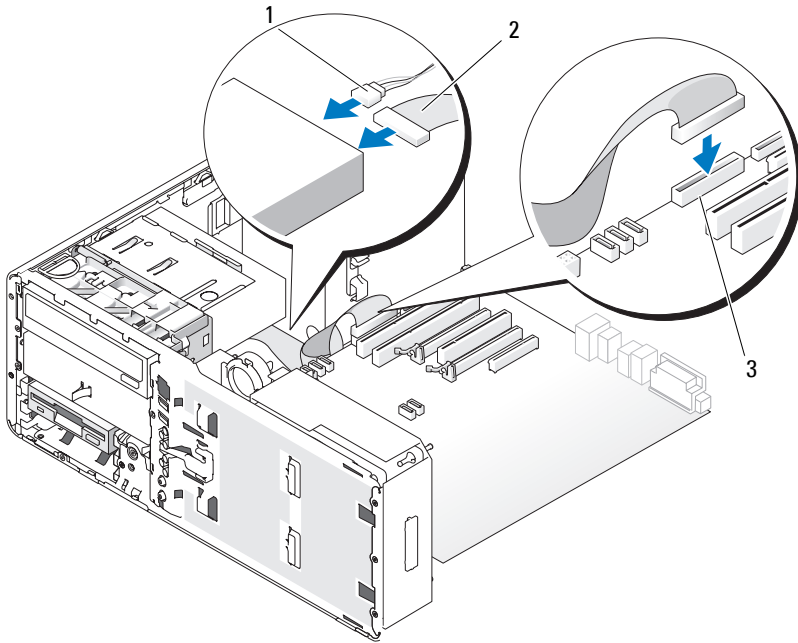

- | | | | |
|---|---|---|------------|
| 1 | power cable | 2 | data cable |
| 3 | floppy-drive connector (DSKT on system board) | | |

- 12 Replace the desktop drive retainer insert and fold the handle down.
 - 13 Check all cable connections, and fold cables out of the way to allow for airflow between the fan and cooling vents.
 - 14 Reinstall the drive panel (see "Replacing the Drive Panel" on page 237).
 - 15 Ensure that all connectors are properly cabled and firmly seated.
 - 16 Replace the computer cover (see "Replacing the Computer Cover" on page 161).
- ➡ NOTICE:** To connect a network cable, first plug the cable in to the network port or device and then plug it in to the computer.

- 17 Connect your computer and devices to their electrical outlets, and turn them on.
See the documentation that came with the drive for instructions on installing any software required for drive operation.
- 18 Enter the system setup program (see "System Setup" on page 89) and select the appropriate **Diskette Drive** option.
- 19 Verify that your computer works correctly by running the Dell Diagnostics. See "Dell Diagnostics" on page 136 for instructions.

Media Card Reader



CAUTION: Before you begin any of the procedures in this section, follow the safety instructions in the *Product Information Guide*.



CAUTION: To guard against electrical shock, always unplug your computer from the electrical outlet before opening the cover.



NOTICE: To prevent static damage to components inside your computer, discharge static electricity from your body before you touch any of your computer's electronic components. You can do so by touching an unpainted metal surface on the computer.



NOTE: If you are adding a Media Card Reader to your *tower* computer, see "Installing a Media Card Reader (Tower Computer)" on page 257.



NOTE: If you are adding a Media Card Reader to your *desktop* computer, see "Installing a Media Card Reader (Desktop Computer)" on page 264.

Removing a Media Card Reader (Tower Computer)

- 1 Follow the procedures in "Before You Begin" on page 151.
- 2 Remove the computer cover (see "Removing the Computer Cover" on page 153).
- 3 Remove the drive panel (see "Removing the Drive Panel" on page 233).
- 4 Disconnect the interface cable from the back of the Media Card Reader.
- 5 Disconnect the other end of the interface cable from the system board connector labeled "USB." To locate the system board connector, see "System Board Components" on page 28.

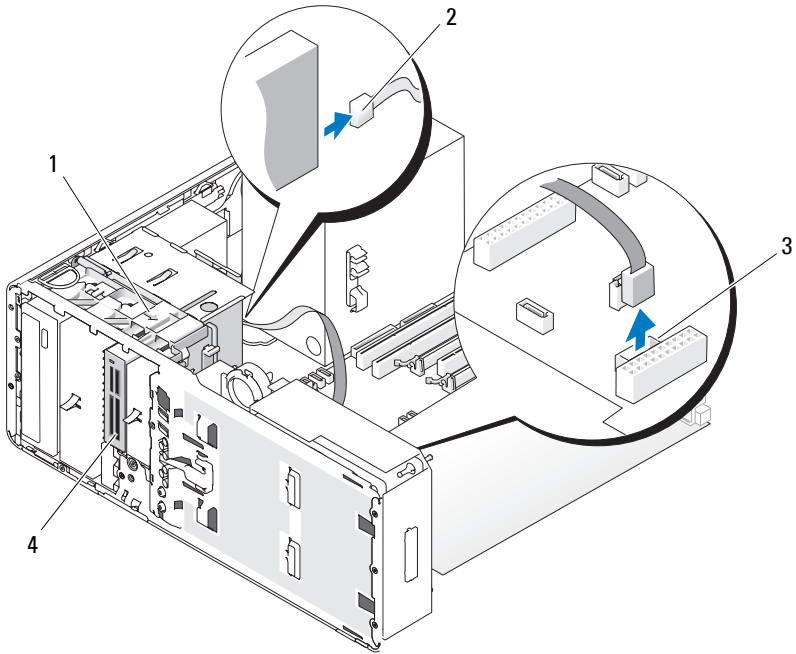

- | | | | |
|---|--|---|-------------------|
| 1 | sliding-plate lever | 2 | interface cable |
| 3 | Media Card Reader connector
(USB on system board) | 4 | Media Card Reader |

- 6** Slide the sliding-plate lever to the right to release the shoulder screw and slide the reader out of the FlexBay.

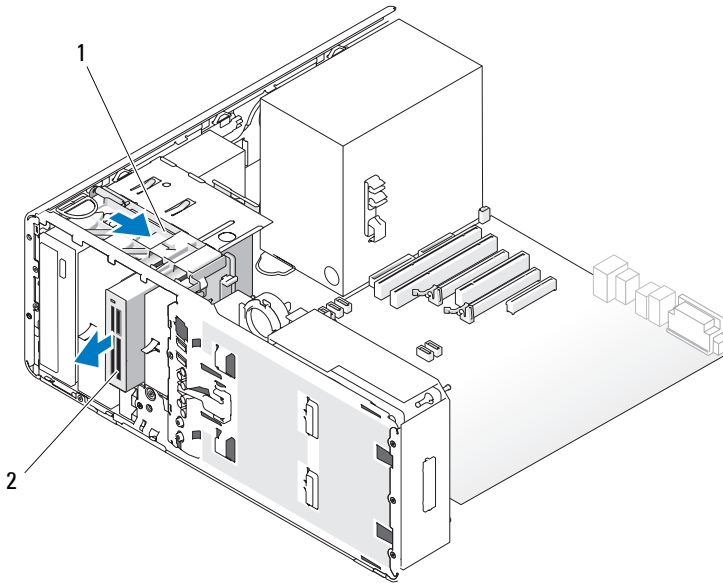

1 sliding-plate lever

2 Media Card Reader





NOTICE: If metal shields are present in your computer configuration, they must be installed at all times while your computer is in use or your computer may not function properly.

- 7 If you are not installing another drive in the drive bay and metal shields are present in your computer (see "About the Metal Shields Present in Some Drive Configurations" on page 207), reinstall the vented metal insert over the FlexBay and the empty space beneath it:
 - a Insert the metal insert's two upper screws and its two lower screws into the corresponding slots inside the FlexBay.
 - b Push the vented metal insert until it clicks into place and its metal tabs rest flush against the chassis surface.

Then, install a drive-panel insert (see "Replacing a Drive-Panel Insert" on page 236).

- 8 If you are installing another drive in the FlexBay, see the appropriate installation instructions in this section.
 - 9 Reinstall the drive panel (see "Replacing the Drive Panel" on page 237).
 - 10 Ensure that all connectors are properly cabled and firmly seated.
 - 11 Replace the computer cover (see "Replacing the Computer Cover" on page 161).
-  **NOTICE:** To connect a network cable, first plug the cable into the network port or device and then plug it into the computer.
- 12 Connect the computer and devices to electrical outlets, and turn them on.

Installing a Media Card Reader (Tower Computer)

-  **NOTICE:** In a tower configuration with 3 hard drives, a Media Card Reader is not supported, since the third hard drive must be installed in the FlexBay.
- 1 Follow the procedures in "Before You Begin" on page 151.
 - 2 Remove the computer cover (see "Removing the Computer Cover" on page 153).
 - 3 Remove the drive panel (see "Removing the Drive Panel" on page 233).
 - 4 If another device is installed in the FlexBay, remove that device (see the appropriate removal instructions in this section).
-  **NOTICE:** If metal shields are present in your computer configuration, they must be installed at all times while your computer is in use or your computer may not function properly.
- 5 If metal shields are present in your computer (see "About the Metal Shields Present in Some Drive Configurations" on page 207) and the FlexBay is not populated, slide the sliding-plate lever to the right and hold it in place as you pull to remove the vented metal insert from the FlexBay.
 - 6 Remove the FlexBay drive-panel insert (see "Removing a Drive-Panel Insert" on page 235).
 - 7 If no screws are attached to the Media Card Reader check the inside of the drive-panel insert for screws and attach them to the new Media Card Reader.

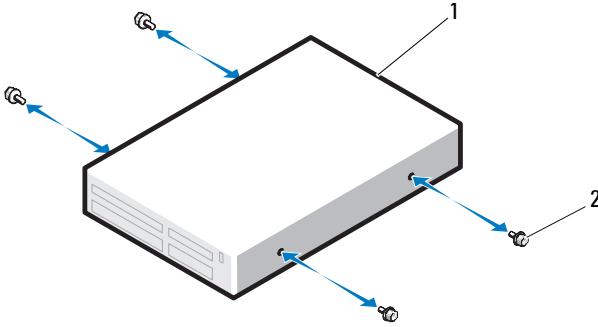

1 Media Card Reader 2 screws

- 8 Gently slide the reader into the FlexBay until you hear a click or feel the reader securely installed.

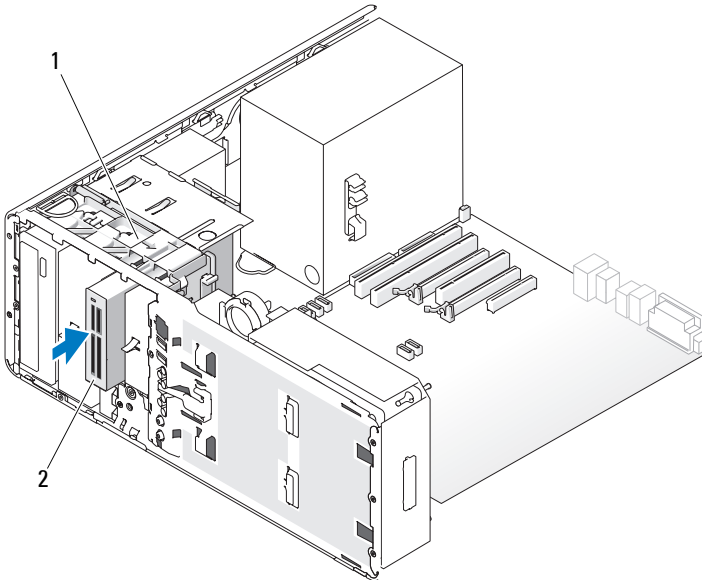

1 sliding-plate lever 2 Media Card Reader

- 9 Attach the interface cable to the Media Card Reader.
- 10 Connect the other end of the interface cable to the system board connector labeled "USB." To locate system board connectors, see "System Board Components" on page 28.

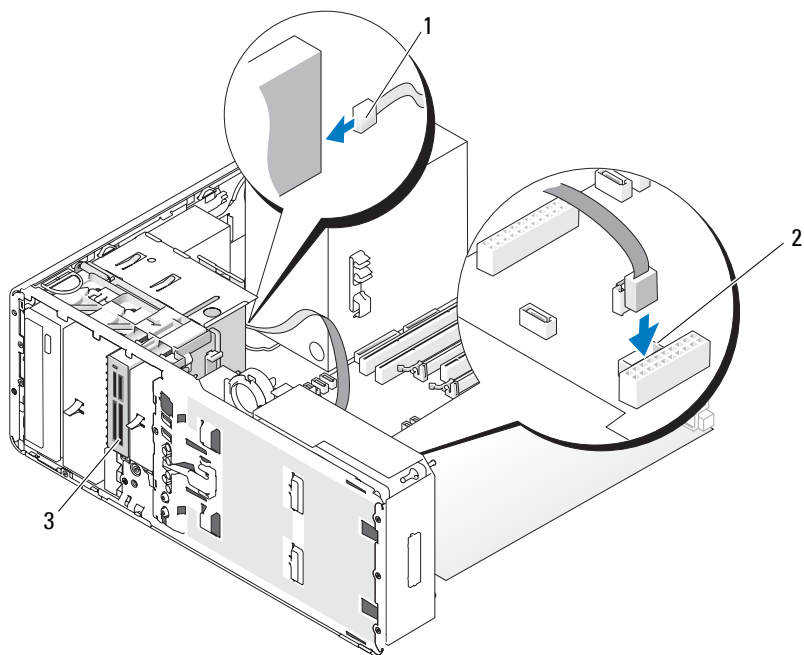

- | | | | |
|---|-------------------|---|--|
| 1 | interface cable | 2 | Media Card Reader connector
(USB on system board) |
| 3 | Media Card Reader | | |

- 11 Check all cable connections, and fold cables out of the way to allow for airflow between the fan and cooling vents.
- 12 Reinstall the drive panel (see "Replacing the Drive Panel" on page 237).
- 13 Ensure that all connectors are properly cabled and firmly seated.
- 14 Replace the computer cover (see "Replacing the Computer Cover" on page 161).

 **NOTICE:** To connect a network cable, first plug the cable in to the network port or device and then plug it in to the computer.

- 15 Connect your computer and devices to their electrical outlets, and turn them on.

See the documentation that came with the drive for instructions on installing any software required for drive operation.

- 16 Enter the system setup program (see "System Setup" on page 89) and select the appropriate **USB for Flexbay** option.
- 17 Verify that your computer works correctly by running the Dell Diagnostics. See "Dell Diagnostics" on page 136 for instructions.

Removing a Media Card Reader (Desktop Computer)

- 1 Follow the procedures in "Before You Begin" on page 151.
- 2 Remove the computer cover (see "Removing the Computer Cover" on page 153).
- 3 Remove the drive panel (see "Removing the Drive Panel" on page 233).
- 4 Disconnect the interface cable from the back of the Media Card Reader.
- 5 Disconnect the other end of the interface cable from the system board connector labeled "USB." To locate the system board connector, see "System Board Components" on page 28.

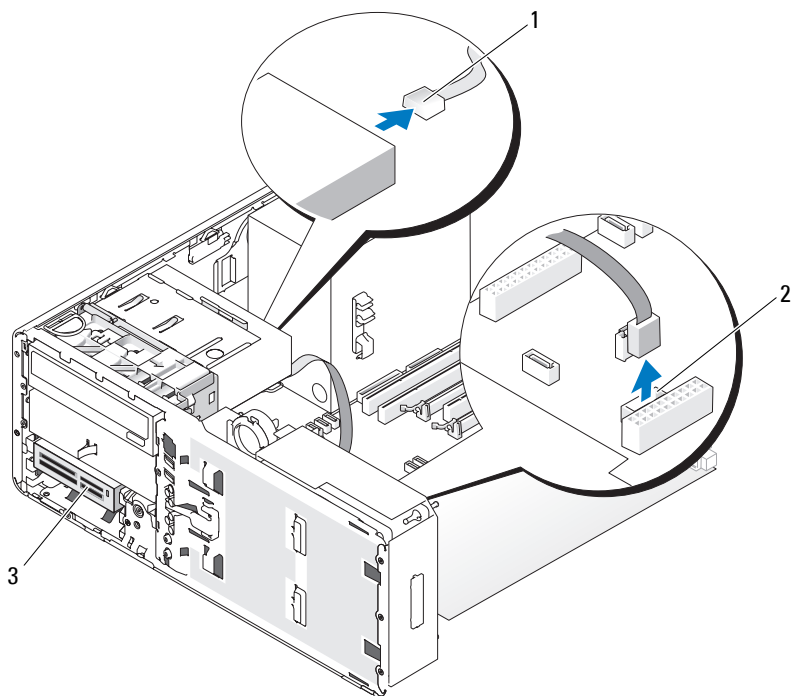

1 interface cable

2 Media Card Reader connector
(USB on system board)

3 Media Card Reader

- 6 Pull the desktop drive retention insert out by the handle and set it aside in a safe place.

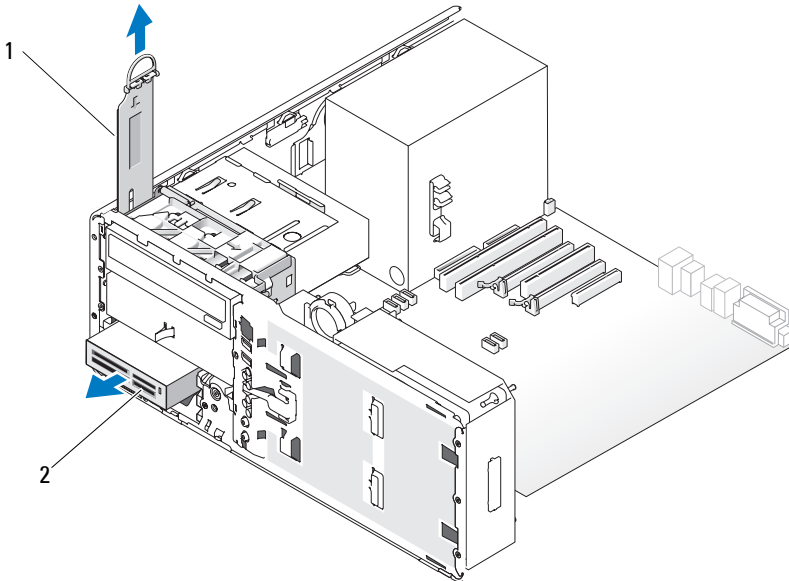

1 drive retention insert

2 Media Card Reader

- 7 Remove the Media Card Reader.
- 8 If you are not installing another drive in the FlexBay and metal shields are present in your computer (see "About the Metal Shields Present in Some Drive Configurations" on page 207), install the vented metal insert over the FlexBay and the empty space beneath it:
 - a Holding the metal insert at an angle, insert its two upper screws into the slot that runs along the inside of the FlexBay.
 - b Rotate the bottom of the vented metal insert down and insert its two bottom screws into the slot in the open area beneath the FlexBay.
 - c Push the vented metal insert until it clicks into place and its metal tabs rest flush against the chassis surface.

Then, install a drive-panel insert (see "Replacing a Drive-Panel Insert" on page 236).

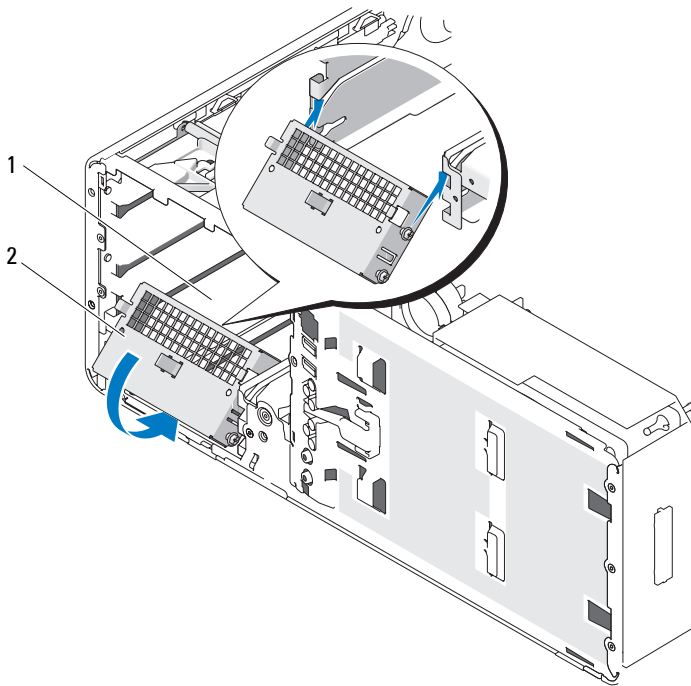

1 FlexBay

2 vented metal insert

- 9 If you are installing another drive in the FlexBay, see the appropriate installation instructions in this section.
- 10 Replace the desktop retention insert and fold down its handle.
- 11 Reinstall the drive panel (see "Replacing the Drive Panel" on page 237).
- 12 Ensure that all connectors are properly cabled and firmly seated.
- 13 Replace the computer cover (see "Replacing the Computer Cover" on page 161).
- ➡ **NOTICE:** To connect a network cable, first plug the cable into the network port or device and then plug it into the computer.
- 14 Connect the computer and devices to electrical outlets, and turn them on.

Installing a Media Card Reader (Desktop Computer)

- 1 Follow the procedures in "Before You Begin" on page 151.
- 2 Remove the computer cover (see "Removing the Computer Cover" on page 153).
- 3 Remove the drive panel (see "Removing the Drive Panel" on page 233).
- 4 Pull the desktop drive retention insert out by the handle and set it aside in a safe place.

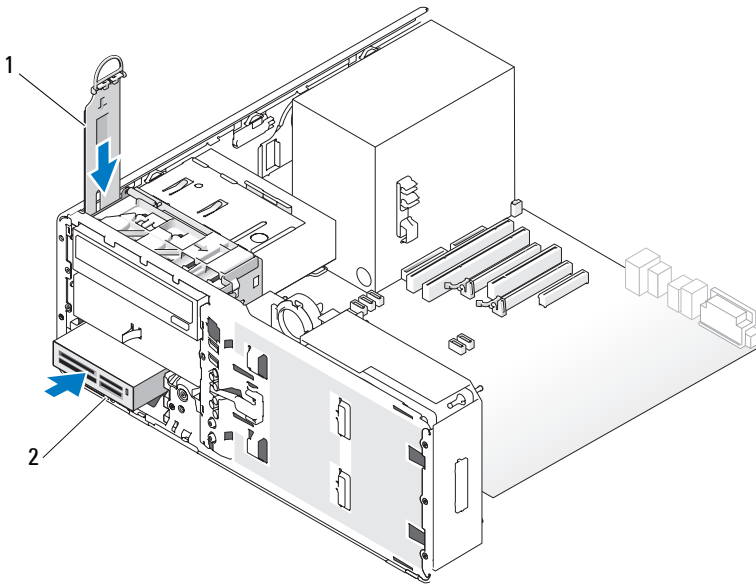

1 drive retention insert

2 Media Card Reader

- 5 If another device is installed in the FlexBay, remove that device (see the appropriate removal instructions in this section).



NOTICE: If metal shields are present in your computer configuration, they must be installed at all times while your computer is in use or your computer may not function properly.

- 6** If the FlexBay is not populated and metal shields are present in your computer (see "About the Metal Shields Present in Some Drive Configurations" on page 207), remove the vented metal insert from the FlexBay:
- a** Pull the vented metal insert forward until its surface is flush with that of the surrounding chassis.
 - b** Rotate the bottom of the metal insert up towards you, disengaging its lower screws from the surrounding metal.
 - c** Lift the metal insert from the computer, disengaging its top screws and metal tabs from the surrounding metal.

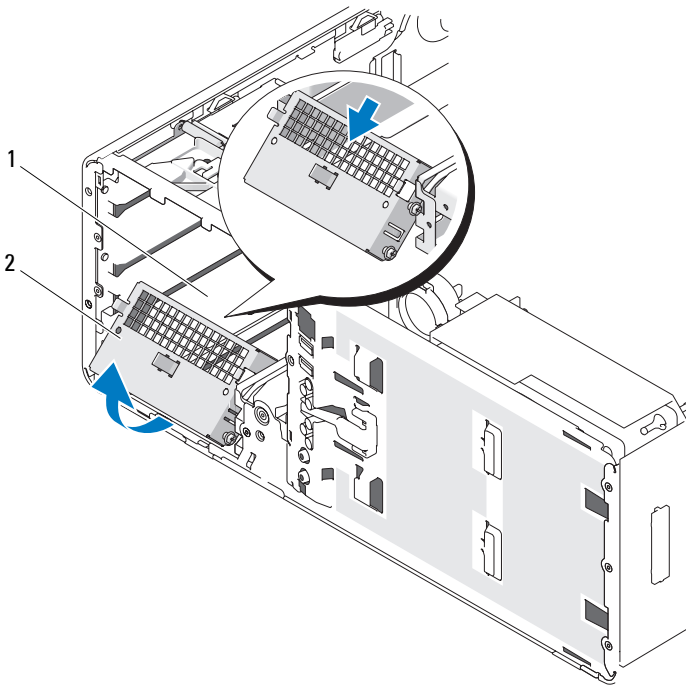

1 FlexBay

2 vented metal insert

- 7** Remove the FlexBay drive-panel insert (see "Removing a Drive-Panel Insert" on page 235).

- 8 If no screws are attached to the reader, remove the shoulder screws from the inside of the drive panel and attach them to the new Media Card Reader.

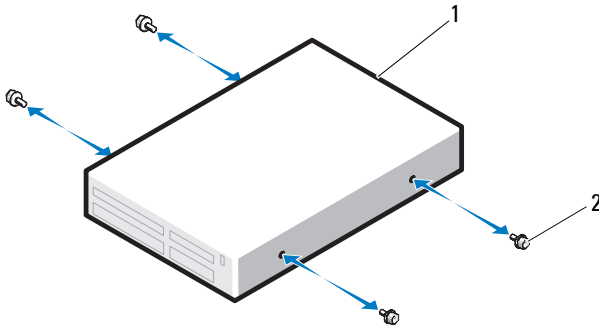

1 drive

2 screws

- 9 Gently slide the reader into place until you hear a click or feel the drive securely installed.
- 10 Attach the interface cable to the Media Card Reader.
- 11 Connect the other end of the interface cable to the system board connector labeled "USB." To locate the system board connector, see "System Board Components" on page 28.

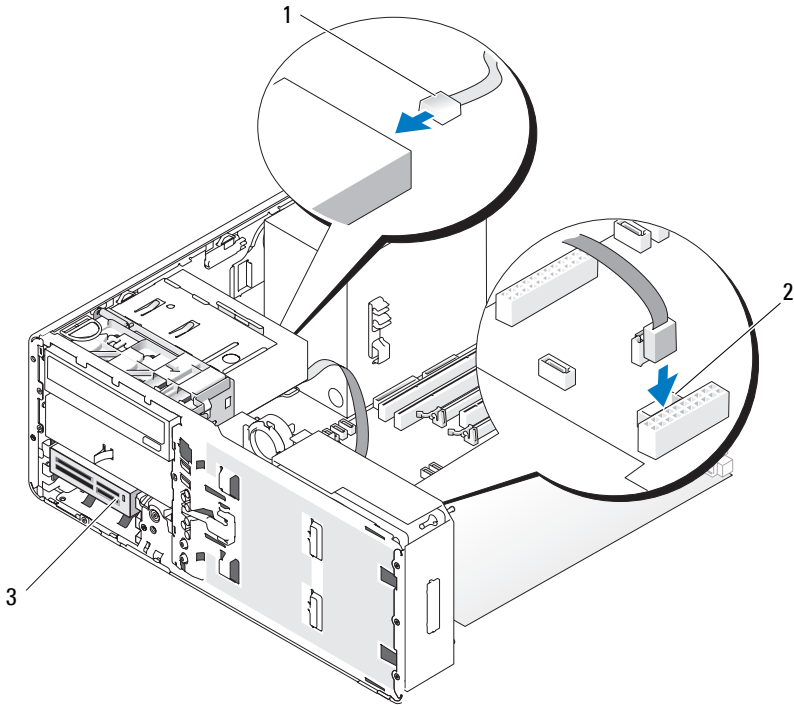

1 interface cable

2 Media Card Reader connector
(USB on system board)

3 Media Card Reader

- 12 Replace the desktop drive retention insert and fold the handle down.
- 13 Check all cable connections, and fold cables out of the way to allow for airflow between the fan and cooling vents.
- 14 Reinstall the drive panel (see "Replacing the Drive Panel" on page 237).
- 15 Ensure that all connectors are properly cabled and firmly seated.
- 16 Replace the computer cover (see "Replacing the Computer Cover" on page 161).

➔ NOTICE: To connect a network cable, first plug the cable in to the network port or device and then plug it in to the computer.

- 17 Connect your computer and devices to their electrical outlets, and turn them on.
See the documentation that came with the drive for instructions on installing any software required for drive operation.
- 18 Enter the system setup program (see "System Setup" on page 89) and select the appropriate **USB for Flexbay** option.
- 19 Verify that your computer works correctly by running the Dell Diagnostics. See "Dell Diagnostics" on page 136 for instructions.

Optical Drive



CAUTION: Before you begin any of the procedures in this section, follow the safety instructions in the *Product Information Guide*.



CAUTION: To guard against electrical shock, always unplug your computer from the electrical outlet before opening the cover.



NOTICE: To prevent static damage to components inside your computer, discharge static electricity from your body before you touch any of your computer's electronic components. You can do so by touching an unpainted metal surface on the computer.

Removing an Optical Drive (Tower Computer)

- 1 Follow the procedures in "Dell Diagnostics" on page 136.
- 2 Remove the computer cover (see "Removing the Computer Cover" on page 153).
- 3 Remove the drive panel (see "Removing the Drive Panel" on page 233).
- 4 Disconnect the power and data cables from the back of the drive.
- 5 If you are uninstalling a SATA optical drive and not replacing it, disconnect the SATA data cable from the system board.

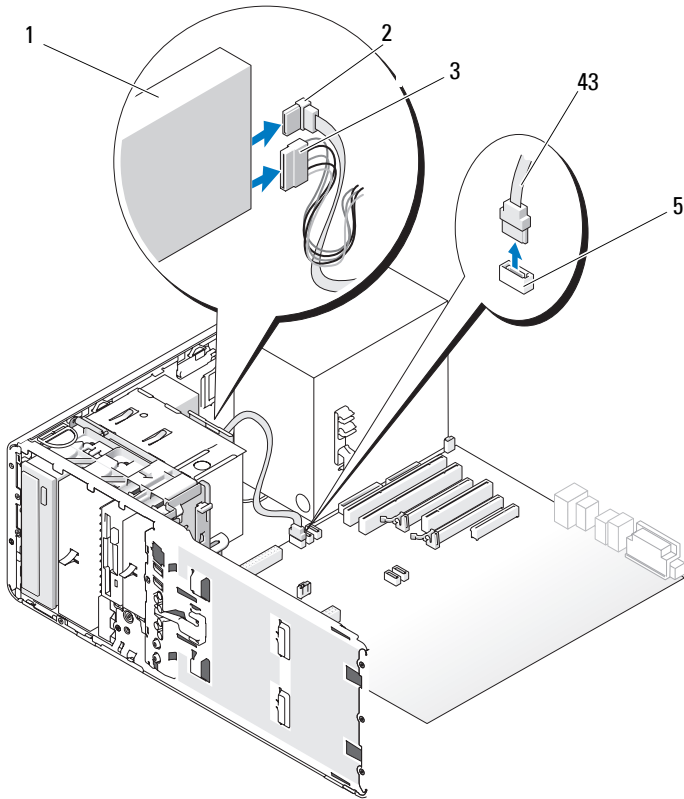

- | | | | |
|---|--------------------------------|---|-----------------|
| 1 | optical drive | 2 | SATA data cable |
| 3 | power cable | 4 | SATA data cable |
| 5 | SATA connector on system board | | |

- 6** Slide the sliding-plate lever to the right to release the shoulder screw and slide the drive out to remove it from the drive bay.

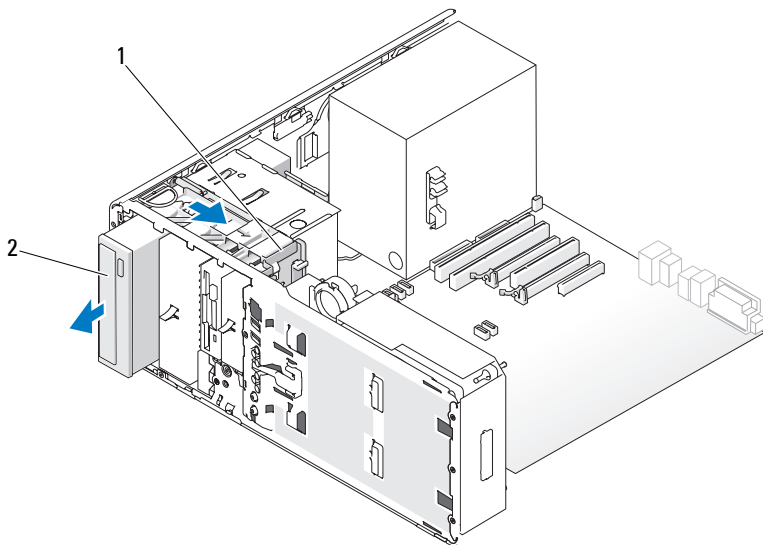

1 sliding-plate lever

2 optical drive



NOTICE: If metal shields are present in your computer configuration, they must be installed at all times while your computer is in use or your computer may not function properly.

- 7 If you are not installing another drive in the optical drive bay and metal shields are present in your computer (see "About the Metal Shields Present in Some Drive Configurations" on page 207):
 - a Install the 5.25-inch metal shield in its place; align its screws in the metal rails and push the shield back until it clicks into place.

 **NOTE:** A metal shield for the optical drive bay can be ordered from Dell. See "Contacting Dell" on page 295.
 - b Install a drive-panel insert over its drive bay (see "Replacing a Drive-Panel Insert" on page 236).
- 8 If you are installing another drive in the optical drive bay, see "Installing an Optical Drive (Tower Computer)" on page 271.
- 9 Reinstall the drive panel (see "Replacing the Drive Panel" on page 237).

- 10 Ensure that all connectors are properly cabled and firmly seated.
- 11 Replace the computer cover (see "Replacing the Computer Cover" on page 161).
-  **NOTICE:** To connect a network cable, first plug the cable into the network port or device and then plug it into the computer.
- 12 Connect the computer and devices to electrical outlets, and turn them on.

Installing an Optical Drive (Tower Computer)

- 1 Follow the procedures in "Before You Begin" on page 151.
- 2 If you are installing a new drive, unpack the drive and prepare it for installation.
Check the documentation that accompanied the drive to verify that the drive is configured for your computer.
- 3 Remove the computer cover (see "Removing the Computer Cover" on page 153).
- 4 Remove the drive panel (see "Removing the Drive Panel" on page 233).
- 5 If another device is installed in the optical drive bay, remove that device (see "Removing an Optical Drive (Tower Computer)" on page 268).
-  **NOTICE:** If metal shields are present in your computer configuration, they must be installed at all times while your computer is in use or your computer may not function properly.
- 6 If the optical drive bay is unpopulated and metal shields are present in your computer (see "About the Metal Shields Present in Some Drive Configurations" on page 207), slide the sliding plate lever to the right and hold it in place as you pull to remove the 5.25-inch metal shield.
- 7 Remove the drive-panel insert (see "Removing a Drive-Panel Insert" on page 235).
- 8 If no screws are attached to the drive, check the inside of the drive panel for shoulder screws and attach them to the new drive.

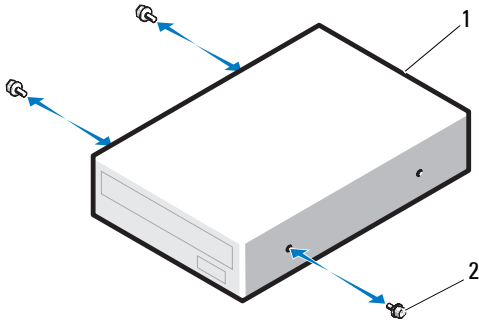

1 optical drive 2 screws

- 9** Gently slide the drive into place until you hear a click or feel the drive securely installed.

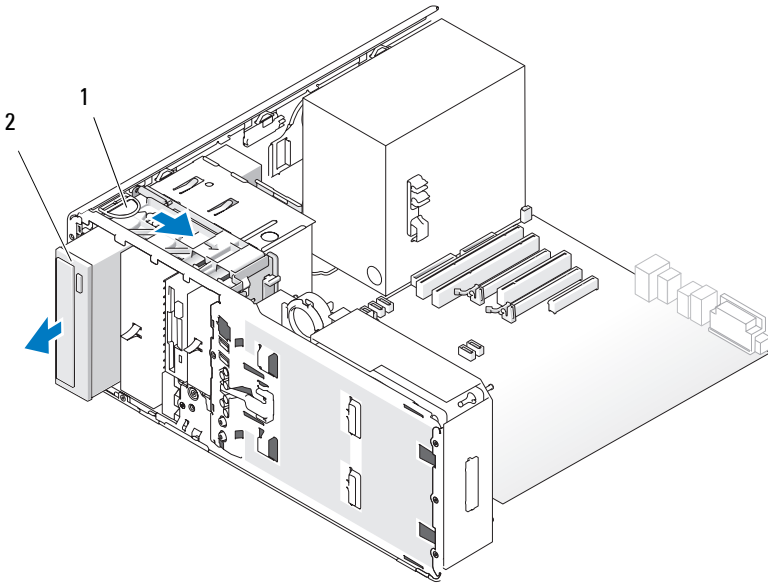

1 drive retention insert 2 optical drive

10 Attach the power and data cables to the optical drive.

If you are installing a SATA drive, connect the other end of the data cable to a SATA connector on the system board.

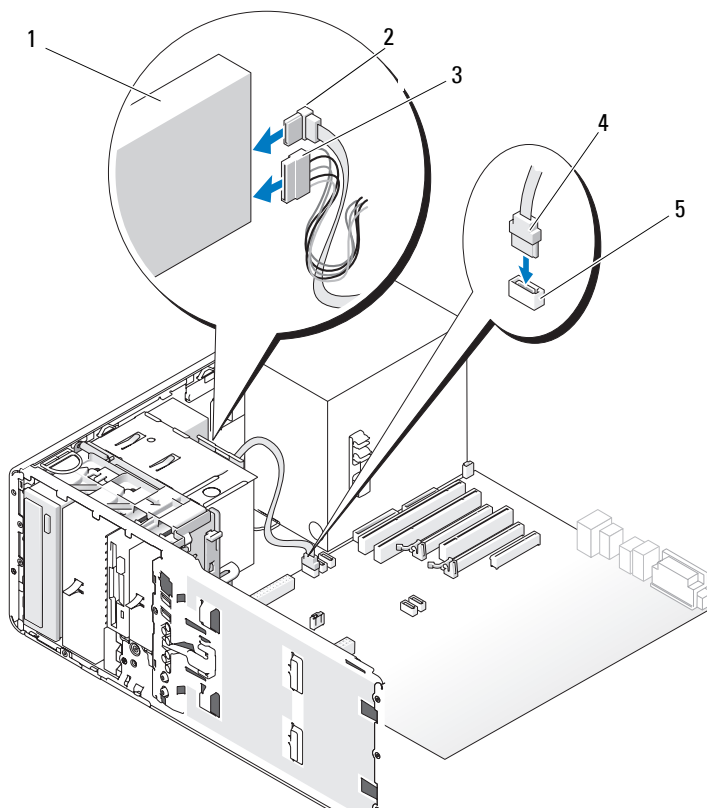

- | | | | |
|---|--------------------------------|---|-----------------|
| 1 | optical drive | 2 | SATA data cable |
| 3 | power cable | 4 | SATA data cable |
| 5 | SATA connector on system board | | |

11 Check all cable connections, and fold cables out of the way to allow for airflow between the fan and cooling vents.

12 Reinstall the drive panel (see "Replacing the Drive Panel" on page 237).

- 13 Ensure that all connectors are properly cabled and firmly seated.
- 14 Replace the computer cover (see "Replacing the Computer Cover" on page 161).
-  **NOTICE:** To connect a network cable, first plug the cable in to the network port or device and then plug it in to the computer.
- 15 Connect your computer and devices to their electrical outlets, and turn them on.

See the documentation that came with the drive for instructions on installing any software required for drive operation.
- 16 Enter the system setup program (see "System Setup" on page 89) and select the appropriate **Drive** option.
- 17 Verify that your computer works correctly by running the Dell Diagnostics. See "Dell Diagnostics" on page 136 for instructions.

Removing an Optical Drive (Desktop Computer)

- 1 Follow the procedures in "Before You Begin" on page 151.
- 2 Remove the computer cover (see "Removing the Computer Cover" on page 153).
- 3 Remove the drive panel (see "Removing the Drive Panel" on page 233).
- 4 Disconnect the power and data cables from the back of the drive.
- 5 If you are uninstalling a SATA optical drive and not replacing it, disconnect the SATA data cable from the system board.

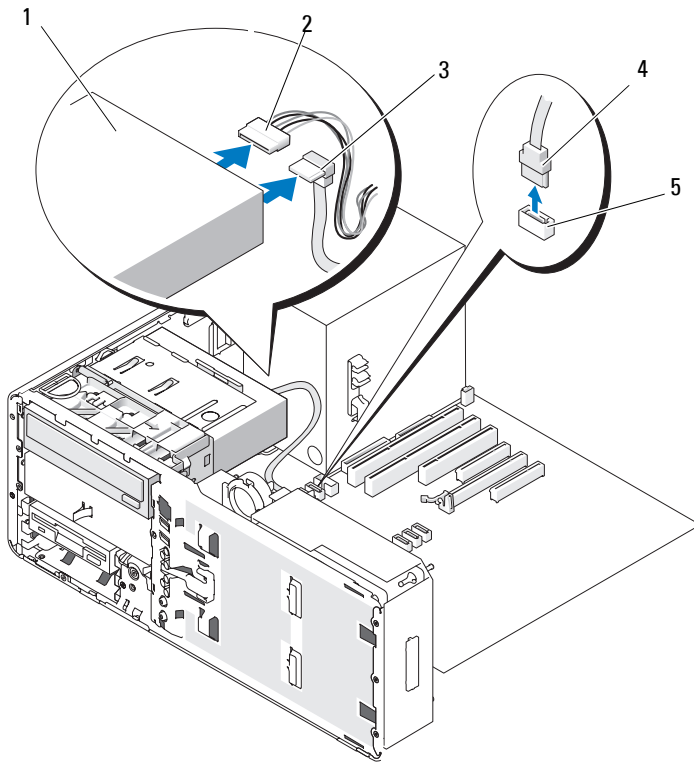

- | | | | |
|---|--------------------------------|---|-----------------|
| 1 | optical drive | 2 | power cable |
| 3 | SATA data cable | 4 | SATA data cable |
| 5 | SATA connector on system board | | |

- 6** Pull the desktop drive retention insert out by the handle and set it aside in a safe place.

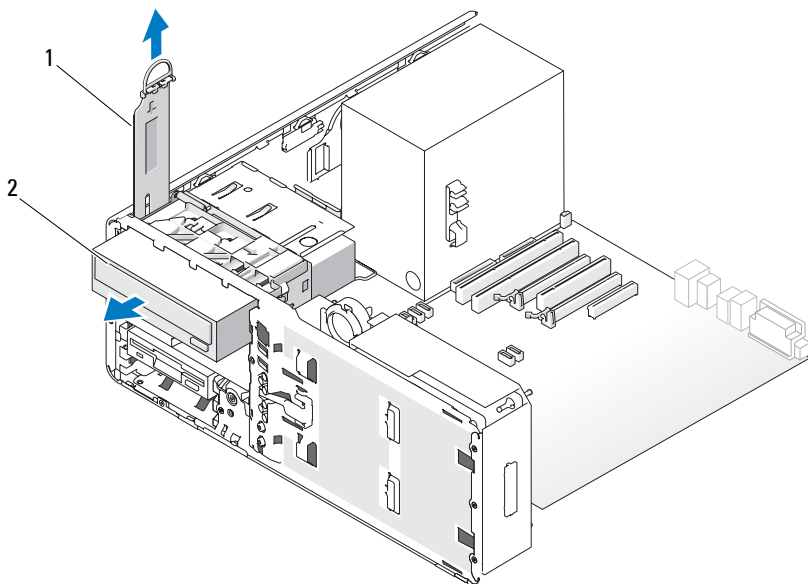

1 drive retention insert 2 optical drive

7 Remove the optical drive from the drive bay.



NOTICE: If metal shields are present in your computer configuration, they must be installed at all times while your computer is in use or your computer may not function properly.

8 If you are not installing another drive in the optical drive bay and metal shields are present in your computer (see "About the Metal Shields Present in Some Drive Configurations" on page 207):

a Install the 5.25-inch metal shield in its place; align its screws in the metal rails and push the shield back until it clicks into place.



NOTE: A metal shield for the optical drive bay can be ordered from Dell. See "Contacting Dell" on page 295.

b Install a drive-panel insert over its drive bay (see "Replacing a Drive-Panel Insert" on page 236).

- 9 If you are installing another drive in the optical drive bay, see the "Installing an Optical Drive (Desktop Computer)" on page 277.
 - 10 Replace the desktop drive retention insert and fold down its handle.
 - 11 Reinstall the drive panel (see "Replacing the Drive Panel" on page 237).
 - 12 Ensure that all connectors are properly cabled and firmly seated.
 - 13 Replace the computer cover (see "Replacing the Computer Cover" on page 161).
-  **NOTICE:** To connect a network cable, first plug the cable into the network port or device and then plug it into the computer.
- 14 Connect the computer and devices to electrical outlets, and turn them on.

Installing an Optical Drive (Desktop Computer)

- 1 Follow the procedures in "Before You Begin" on page 151.
- 2 If you are installing a new drive, unpack the drive and prepare it for installation.

Check the documentation that accompanied the drive to verify that the drive is configured for your computer.
- 3 Remove the computer cover (see "Removing the Computer Cover" on page 153).
- 4 Remove the drive panel (see "Removing the Drive Panel" on page 233).
- 5 Pull the desktop drive retention insert out by the handle and set it aside in a safe place.

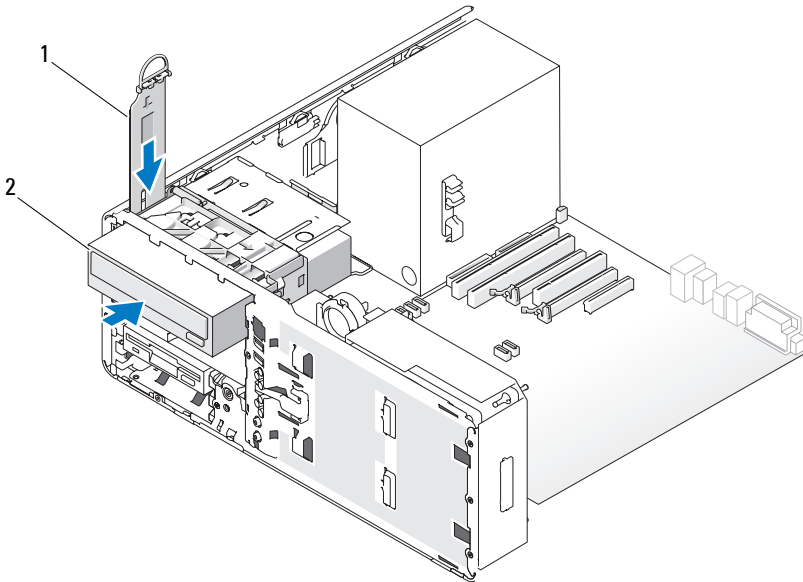

1 drive retention insert 2 optical drive

- 6 If another device is installed in the optical drive bay, remove that device (see "Removing an Optical Drive (Desktop Computer)" on page 274).

NOTICE: If metal shields are present in your computer configuration, they must be installed at all times while your computer is in use or your computer may not function properly.

- 7 If the optical drive bay is unpopulated and metal shields are present in your computer (see "About the Metal Shields Present in Some Drive Configurations" on page 207), pull to remove the 5.25-inch metal shield.
- 8 Remove the drive-panel insert (see "Removing a Drive-Panel Insert" on page 235).
- 9 If no screws are attached to the drive, remove the shoulder screws from the inside of the drive panel and attach the screws to the new drive.

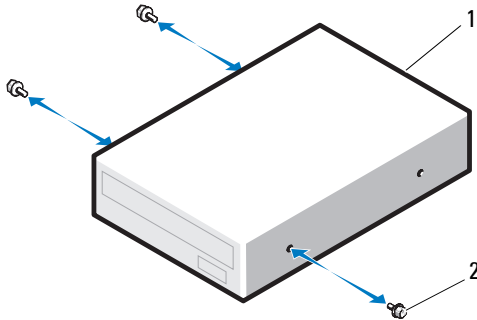

1 optical drive 2 screws

10 Gently slide the drive into place until you hear a click or feel the drive securely installed.

➔ NOTICE: Do not attach a SATA optical drive to an HDD connector on the system board or it will not function. Attach SATA optical drives to the connectors labeled SATA on the system board.

11 Attach the power and data cables to the optical drive.

If you are installing a SATA drive, connect the other end of the data cable to a SATA connector on the system board.

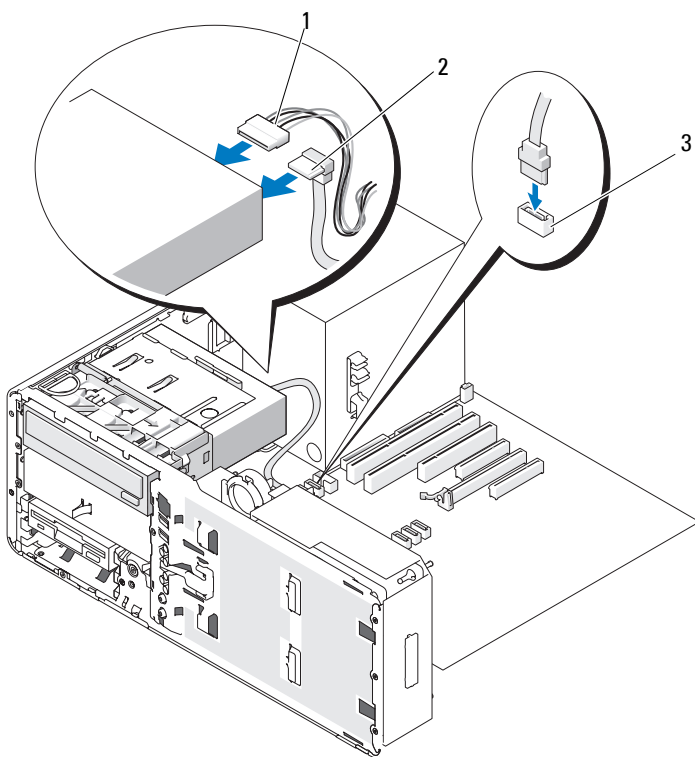

- 1 power cable
- 2 SATA data cable
- 3 SATA data connector on system board

- 12** Replace the desktop drive retention insert and fold down its handle.
- 13** Check all cable connections, and fold cables out of the way to allow for airflow between the fan and cooling vents.
- 14** Reinstall the drive panel (see "Replacing the Drive Panel" on page 237).
- 15** Ensure that all connectors are properly cabled and firmly seated.

16 Replace the computer cover (see "Replacing the Computer Cover" on page 161).

 **NOTICE:** To connect a network cable, first plug the cable in to the network port or device and then plug it in to the computer.

17 Connect your computer and devices to their electrical outlets, and turn them on.

See the documentation that came with the drive for instructions on installing any software required for drive operation.

18 Enter the system setup program (see "System Setup" on page 89) and select the appropriate **Drive** option.

19 Verify that your computer works correctly by running the Dell Diagnostics. See "Dell Diagnostics" on page 136 for instructions.

System Board

 **CAUTION:** Before you begin any of the procedures in this section, follow the safety instructions in the *Product Information Guide*.

 **CAUTION:** To guard against electrical shock, always unplug your computer from the electrical outlet before opening the cover.

 **NOTICE:** To prevent static damage to components inside your computer, discharge static electricity from your body before you touch any of your computer's electronic components. You can do so by touching an unpainted metal surface on the computer.

Removing the System Board

1 Follow the procedures in "Before You Begin" on page 151.

2 Remove the computer cover (see "Removing the Computer Cover" on page 153).

3 Rotate the hard-drive carrier out of the computer (see "Rotating the Hard Drive Carrier Out of the Computer" on page 156).

4 Remove the processor access door assembly:

a Remove the green screw that attaches the processor access door assembly to the system board and to the computer chassis.

b Lift to remove the processor access door assembly from the computer.

- 5 Use a long Phillips screwdriver to loosen the four captive screws on the sides of the heat-sink assembly.

CAUTION: The heat-sink assembly may become very hot during normal operation. Ensure that it has had sufficient time to cool before you touch it.

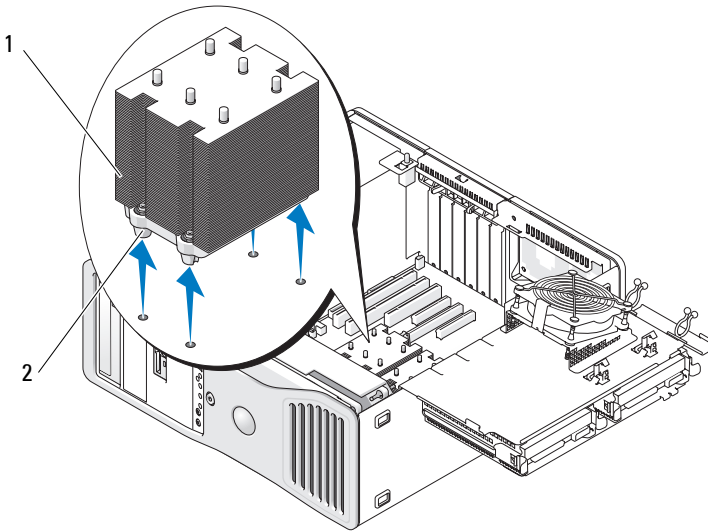

- 1 heat sink assembly 2 captive screw housing (4)

- 6 Lift to remove the heat-sink assembly from the computer.
- 7 Disconnect the optional speaker connector (if installed) from the system board.
- 8 Disconnect the card fan from the system board connector labeled FAN_CCAG (see "System Board Components" on page 28.)

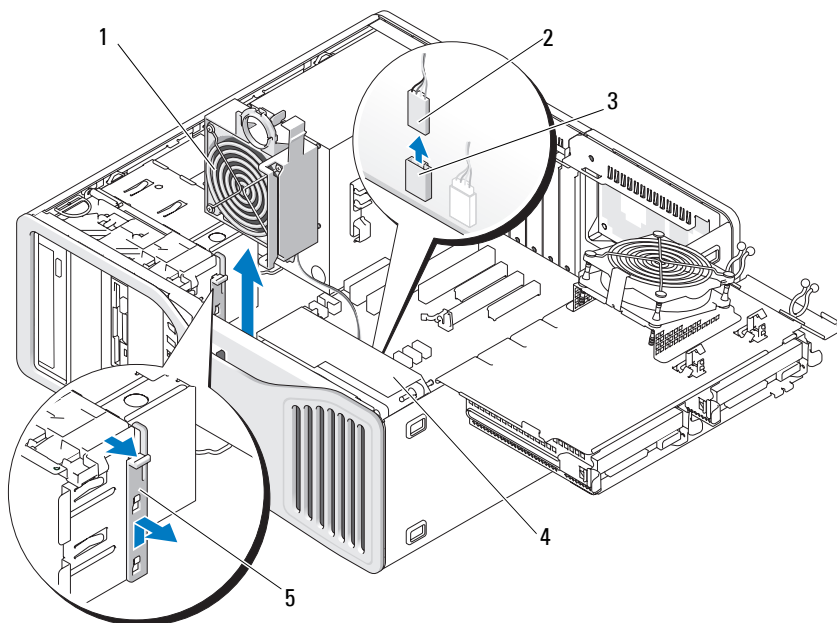

- | | | | |
|---|--|---|----------------|
| 1 | card fan | 2 | card fan cable |
| 3 | card fan system-board connector (FAN_CCAG) | 4 | front fan |
| 5 | full-length card retainer piece | | |

- 9 Disconnect the front fan from the connector labeled FAN_FRONT on the system board (see "System Board Components" on page 28.)
- 10 If the system is in tower mode, pull to remove the full-length card retainer piece beside the card fan.
- 11 Disconnect the Power1 and Power2 connectors from the system board (see "System Board Components" on page 28).
- 12 Remove the cables from the cable guide on the front fan.
- 13 Press the tab between the card fan and the front fan towards the card fan as you lift it up and out of the computer.
- 14 Unscrew the fan case and lift to remove it from the computer.

- 15 Remove any components that restrict access to the system board.
- 16 Disconnect all cables from the system board.
- 17 Before you remove the existing system board, visually compare the replacement system board to the existing system board to make sure that you have the correct part.
- 18 Remove the nine system board screws.

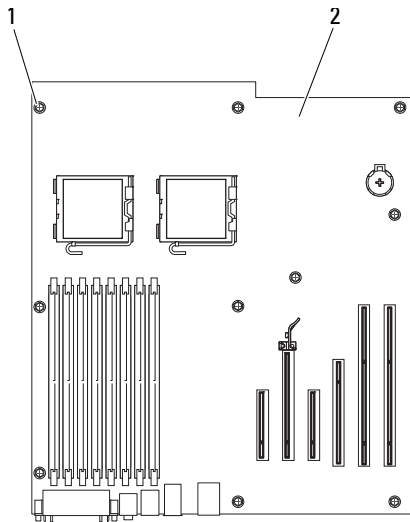

1 screws (9) 2 system board

- 19 Lift the system board from the computer.
- 20 Place the system board that you just removed next to the replacement system board.

Replacing the System Board

- 1 Transfer components from the existing system board to the replacement system board:
 - a Remove the memory modules and install them on the replacement board (see "Memory" on page 187 for more information).



CAUTION: The processor package and heat-sink assembly can get hot. To avoid burns, ensure that the package and assembly have had sufficient time to cool before you touch them.

b Remove the processor from the existing system board and transfer the processor to the replacement system board. See "Processor" on page 179 for more information.

- 2 Set the jumpers on the replacement system board so that they are identical to the ones on the existing board (see "System Board Components" on page 28.)



NOTE: Some components and connectors on the replacement system board may be in different locations than the corresponding connectors on the existing system board.

- 3 Orient the replacement board by aligning the screw holes in the board with the corresponding holes in the computer chassis.
- 4 Screw in the 9 screws that attach the system board.
- 5 Replace the heat sink assembly and tighten the four captive screws to secure it to the system board.
- 6 Replace any components and cables that you removed from the system board.
- 7 Reconnect all cables to their connectors at the back of the computer.
- 8 Replace the computer cover (see "Replacing the Computer Cover" on page 161).



NOTICE: To connect a network cable, first plug the cable into the network port or device and then plug it into the computer.

- 9 Connect your computer and devices to electrical outlets, and turn them on.

Getting Help

Obtaining Assistance

 **CAUTION:** If you need to remove the computer cover, first disconnect the computer power and modem cables from all electrical outlets.

If you experience a problem with your computer, you can complete the following steps to diagnose and troubleshoot the problem:

- 1 See "Troubleshooting" on page 107 for information and procedures that pertain to the problem your computer is experiencing.
- 2 See "Dell Diagnostics" on page 136 for procedures on how to run Dell Diagnostics.
- 3 Fill out the "Diagnostics Checklist" on page 294.
- 4 Use Dell's extensive suite of online services available at Dell Support (support.dell.com) for help with installation and troubleshooting procedures. See "Online Services" on page 290 for a more extensive list of Dell Support online.
- 5 If the preceding steps have not resolved the problem, see "Contacting Dell" on page 295.

 **NOTE:** Call Dell Support from a telephone near or at the computer so that the support staff can assist you with any necessary procedures.

 **NOTE:** Dell's Express Service Code system may not be available in all countries.

When prompted by Dell's automated telephone system, enter your Express Service Code to route the call directly to the proper support personnel. If you do not have an Express Service Code, open the **Dell Accessories** folder, double-click the **Express Service Code** icon, and follow the directions.

For instructions on using the Dell Support, see "Technical Support and Customer Service" on page 290.



NOTE: Some of the following services are not always available in all locations outside the continental U.S. Call your local Dell representative for information on availability.

Technical Support and Customer Service

Dell's support service is available to answer your questions about Dell™ hardware. Our support staff uses computer-based diagnostics to provide fast, accurate answers.

To contact Dell's support service, see "Before You Call" on page 292, and then see the contact information for your region or go to support.dell.com.

Online Services

You can learn about Dell products and services on the following websites:

www.dell.com

www.dell.com/ap (Asian/Pacific countries only)

www.dell.com/jp (Japan only)

www.euro.dell.com (Europe only)

www.dell.com/la (Latin American and Caribbean countries)

www.dell.ca (Canada only)

You can access Dell Support through the following websites and e-mail addresses:

- Dell Support websites
support.dell.com
support.jp.dell.com (Japan only)
support.euro.dell.com (Europe only)
- Dell Support e-mail addresses
mobile_support@us.dell.com
support@us.dell.com
la-techsupport@dell.com (Latin America and Caribbean countries only)
apsupport@dell.com (Asian/Pacific countries only)

- Dell Marketing and Sales e-mail addresses
apmarketing@dell.com (Asian/Pacific countries only)
sales_canada@dell.com (Canada only)
- Anonymous file transfer protocol (FTP)
ftp.dell.com
Log in as user: anonymous, and use your e-mail address as your password.

AutoTech Service

Dell's automated support service—AutoTech—provides recorded answers to the questions most frequently asked by Dell customers about their portable and desktop computers.

When you call AutoTech, use your touch-tone telephone to select the subjects that correspond to your questions. For the telephone number to call for your region, see "Contacting Dell" on page 295.

Automated Order-Status Service

To check on the status of any Dell products that you have ordered, you can go to support.dell.com, or you can call the automated order-status service. A recording prompts you for the information needed to locate and report on your order. For the telephone number to call for your region, see "Contacting Dell" on page 295.

Problems With Your Order

If you have a problem with your order, such as missing parts, wrong parts, or incorrect billing, contact Dell for customer assistance. Have your invoice or packing slip handy when you call. For the telephone number to call for your region, see "Contacting Dell" on page 295.

Product Information

If you need information about additional products available from Dell, or if you would like to place an order, visit the Dell website at www.dell.com. For the telephone number to call for your region or to speak to a sales specialist, see "Contacting Dell" on page 295.

Returning Items for Warranty Repair or Credit

Prepare all items being returned, whether for repair or credit, as follows:

- 1 Call Dell to obtain a Return Material Authorization Number, and write it clearly and prominently on the outside of the box.
For the telephone number to call for your region, see "Contacting Dell" on page 295.
- 2 Include a copy of the invoice and a letter describing the reason for the return.
- 3 Include a copy of the Diagnostics Checklist (see "Diagnostics Checklist" on page 294), indicating the tests that you have run and any error messages reported by the Dell Diagnostics (see "Dell Diagnostics" on page 136).
- 4 Include any accessories that belong with the item(s) being returned (power cables, software floppy disks, guides, and so on) if the return is for credit.
- 5 Pack the equipment to be returned in the original (or equivalent) packing materials.

You are responsible for paying shipping expenses. You are also responsible for insuring any product returned, and you assume the risk of loss during shipment to Dell. Collect On Delivery (C.O.D.) packages are not accepted.

Returns that are missing any of the preceding requirements will be refused at Dell's receiving dock and returned to you.

Before You Call



NOTE: Have your Express Service Code ready when you call. The code helps Dell's automated-support telephone system direct your call more efficiently. You may also be asked for your Service Tag (located on the back or bottom of your computer).

Remember to fill out the Diagnostics Checklist (see "Diagnostics Checklist" on page 294). If possible, turn on your computer before you call Dell for assistance and call from a telephone at or near the computer. You may be asked to type some commands at the keyboard, relay detailed information during operations, or try other troubleshooting steps possible only at the computer itself. Ensure that the computer documentation is available.



CAUTION: Before working inside your computer, follow the safety instructions in your *Product Information Guide*.

Diagnostics Checklist

Name:

Date:

Address:

Phone number:

Service Tag (bar code on the back or bottom of the computer):

Express Service Code:

Return Material Authorization Number (if provided by Dell support technician):

Operating system and version:

Devices:

Expansion cards:

Are you connected to a network? Yes No

Network, version, and network adapter:

Programs and versions:

See your operating system documentation to determine the contents of the system's start-up files. If the computer is connected to a printer, print each file. Otherwise, record the contents of each file before calling Dell.

Error message, beep code, or diagnostic code:

Description of problem and troubleshooting procedures you performed:

Contacting Dell

For customers in the United States, call 800.WWW.DELL (800.999.3355).



NOTE: If you do not have an active Internet connection, you can find contact information on your purchase invoice, packing slip, bill, or Dell product catalog.

Dell provides several online and telephone-based support and service options. Availability varies by country and product, and some services may not be available in your area. To contact Dell for sales, technical support, or customer service issues:

- 1 Visit support.dell.com.
- 2 Verify your country or region in the **Choose A Country/Region** drop-down menu at the bottom of the page.
- 3 Click **Contact Us** on the left side of the page.
- 4 Select the appropriate service or support link based on your need.
- 5 Choose the method of contacting Dell that is convenient for you.

Appendix

FCC Notice (U.S. Only)

FCC Class B

This equipment generates, uses, and can radiate radio frequency energy and, if not installed and used in accordance with the manufacturer's instruction manual, may cause interference with radio and television reception. This equipment has been tested and found to comply with the limits for a Class B digital device pursuant to Part 15 of the FCC Rules.

This device complies with Part 15 of the FCC Rules. Operation is subject to the following two conditions:

- 1 This device may not cause harmful interference.
- 2 This device must accept any interference received, including interference that may cause undesired operation.



NOTICE: The FCC regulations provide that changes or modifications not expressly approved by Dell Inc. could void your authority to operate this equipment.

These limits are designed to provide reasonable protection against harmful interference in a residential installation. However, there is no guarantee that interference will not occur in a particular installation. If this equipment does cause harmful interference with radio or television reception, which can be determined by turning the equipment off and on, you are encouraged to try to correct the interference by one or more of the following measures:

- Reorient the receiving antenna.
- Relocate the system with respect to the receiver.
- Move the system away from the receiver.
- Plug the system into a different outlet so that the system and the receiver are on different branch circuits.

If necessary, consult a representative of Dell Inc. or an experienced radio/television technician for additional suggestions.

The following information is provided on the device or devices covered in this document in compliance with the FCC regulations:

- Product name: Dell™ Precision™ T5400
- Model number: DCTA
- Company name:
Dell Inc.
Worldwide Regulatory Compliance & Environmental Affairs
One Dell Way
Round Rock, TX 78682 USA
512-338-4400



NOTE: For further regulatory information, see your *Product Information Guide*.

Glossary

Terms in this Glossary are provided for informational purposes only and may or may not describe features included with your particular computer.

A

AC — alternating current — The form of electricity that powers your computer when you plug the AC adapter power cable in to an electrical outlet.

ACPI — advanced configuration and power interface — A power management specification that enables Microsoft® Windows® operating systems to put a computer in standby or hibernate mode to conserve the amount of electrical power allocated to each device attached to the computer.

AGP — accelerated graphics port — A dedicated graphics port that allows system memory to be used for video-related tasks. AGP delivers a smooth, true-color video image because of the faster interface between the video circuitry and the computer memory.

AHCI — Advanced Host Controller Interface — An interface for a SATA hard drive Host Controller which allows the storage driver to enable technologies such as Native Command Queuing (NCQ) and hot plug.

ALS — ambient light sensor — A feature that helps to control display brightness.

antivirus software — A program designed to identify, quarantine, and/or delete viruses from your computer.

ASF — alert standards format — A standard to define a mechanism for reporting hardware and software alerts to a management console. ASF is designed to be platform- and operating system-independent.

B

battery life span — The length of time (years) during which a portable computer battery is able to be depleted and recharged.

battery operating time — The length of time (minutes or hours) that a portable computer battery powers the computer.

BIOS — basic input/output system — A program (or utility) that serves as an interface between the computer hardware and the operating system. Unless you

understand what effect these settings have on the computer, do not change them. Also referred to as *system setup*.

bit — The smallest unit of data interpreted by your computer.

Blu-ray Disc™ (BD) — An optical storage technology offering storage capacity of up to 50 GB, full 1080p video resolution (HDTV required), and as many as 7.1 channels of native, uncompressed surround sound.

Bluetooth® wireless technology — A wireless technology standard for short-range (9 m [29 feet]) networking devices that allows for enabled devices to automatically recognize each other.

boot sequence — Specifies the order of the devices from which the computer attempts to boot.

bootable media — A CD, DVD, or floppy disk that you can use to start your computer. In case your hard drive is damaged or your computer has a virus, ensure that you always have a bootable CD, DVD, or floppy disk available. Your *Drivers and Utilities* media is an example of bootable media.

bps — bits per second — The standard unit for measuring data transmission speed.

BTU — British thermal unit — A measurement of heat output.

bus — A communication pathway between the components in your computer.

bus speed — The speed, given in MHz, that indicates how fast a bus can transfer information.

byte — The basic data unit used by your computer. A byte is usually equal to 8 bits.

C

C — Celsius — A temperature measurement scale where 0° is the freezing point and 100° is the boiling point of water.

cache — A special high-speed storage mechanism which can be either a reserved section of main memory or an independent high-speed storage device. The cache enhances the efficiency of many processor operations.

L1 cache — Primary cache stored inside the processor.

L2 cache — Secondary cache which can either be external to the processor or incorporated into the processor architecture.

carnet — An international customs document that facilitates temporary imports into foreign countries. Also known as a *merchandise passport*.

CD-R — CD recordable — A recordable version of a CD. Data can be recorded only once onto a CD-R. Once recorded, the data cannot be erased or written over.

CD-RW — CD rewritable — A rewritable version of a CD. Data can be written to a CD-RW disc, and then erased and written over (rewritten).

CD-RW drive — A drive that can read CDs and write to CD-RW (rewritable CDs) and CD-R (recordable CDs) discs. You can write to CD-RW discs multiple times, but you can write to CD-R discs only once.

CD-RW/DVD drive — A drive, sometimes referred to as a combo drive, that can read CDs and DVDs and write to CD-RW (rewritable CDs) and CD-R (recordable CDs) discs. You can write to CD-RW discs multiple times, but you can write to CD-R discs only once.

clock speed — The speed, given in MHz, that indicates how fast computer components that are connected to the system bus operate.

CMOS — A type of electronic circuit. Computers use a small amount of battery-powered CMOS memory to hold date, time, and system setup options.

COA — Certificate of Authenticity — The Windows alpha-numeric code located on a sticker on your computer. Also referred to as the *Product Key* or *Product ID*.

Control Panel — A Windows utility that allows you to modify operating system and hardware settings, such as display settings.

controller — A chip that controls the transfer of data between the processor and memory or between the processor and devices.

CRIMM — continuity rambus in-line memory module — A special module that has no memory chips and is used to fill unused RIMM slots.

cursor — The marker on a display or screen that shows where the next keyboard, touch pad, or mouse action will occur. It often is a blinking solid line, an underline character, or a small arrow.

D

DDR SDRAM — double-data-rate SDRAM — A type of SDRAM that doubles the data burst cycle, improving system performance.

DDR2 SDRAM — double-data-rate 2 SDRAM — A type of DDR SDRAM that uses a 4-bit prefetch and other architectural changes to boost memory speed to over 400 MHz.

device — Hardware such as a disk drive, printer, or keyboard that is installed in or connected to your computer.

device driver — See *driver*.

DIMM — dual in-line memory module — A circuit board with memory chips that connects to a memory module on the system board.

DIN connector — A round, six-pin connector that conforms to DIN (Deutsche Industrie-Norm) standards; it is typically used to connect PS/2 keyboard or mouse cable connectors.

disk striping — A technique for spreading data over multiple disk drives. Disk striping can speed up operations that retrieve data from disk storage. Computers that use disk striping generally allow the user to select the data unit size or stripe width.

DMA — direct memory access — A channel that allows certain types of data transfer between RAM and a device to bypass the processor.

docking device — provides port replication, cable management, and security features to adapt your notebook to a desktop workspace.

DMTF — Distributed Management Task Force — A consortium of hardware and software companies who develop management standards for distributed desktop, network, enterprise, and Internet environments.

domain — A group of computers, programs, and devices on a network that are administered as a unit with common rules and procedures for use by a specific group of users. A user logs on to the domain to gain access to the resources.

DRAM — dynamic random-access memory — Memory that stores information in integrated circuits containing capacitors.

driver — Software that allows the operating system to control a device such as a printer. Many devices do not work properly if the correct driver is not installed in the computer.

DSL — Digital Subscriber Line — A technology that provides a constant, high-speed Internet connection through an analog telephone line.

dual-core — A technology in which two physical computational units exist inside a single processor package, thereby increasing computing efficiency and multi-tasking ability.

dual display mode — A display setting that allows you to use a second monitor as an extension of your display. Also referred to as *extended display mode*.

DVD-R — DVD recordable — A recordable version of a DVD. Data can be recorded only once onto a DVD-R. Once recorded, the data cannot be erased or written over.

DVD+RW — DVD rewritable — A rewritable version of a DVD. Data can be written to a DVD+RW disc, and then erased and written over (rewritten). (DVD+RW technology is different from DVD-RW technology.)

DVD+RW drive — drive that can read DVDs and most CD media and write to DVD+RW (rewritable DVDs) discs.

DVI — digital video interface — A standard for digital transmission between a computer and a digital video display.

E

ECC — error checking and correction — A type of memory that includes special circuitry for testing the accuracy of data as it passes in and out of memory.

ECP — extended capabilities port — A parallel connector design that provides improved bidirectional data transmission. Similar to EPP, ECP uses direct memory access to transfer data and often improves performance.

EIDE — enhanced integrated device electronics — An improved version of the IDE interface for hard drives and CD drives.

EMI — electromagnetic interference — Electrical interference caused by electromagnetic radiation.

ENERGY STAR® — Environmental Protection Agency requirements that decrease the overall consumption of electricity.

EPP — enhanced parallel port — A parallel connector design that provides bidirectional data transmission.

ESD — electrostatic discharge — A rapid discharge of static electricity. ESD can damage integrated circuits found in computer and communications equipment.

expansion card — A circuit board that installs in an expansion slot on the system board in some computers, expanding the capabilities of the computer. Examples include video, modem, and sound cards.

expansion slot — A connector on the system board (in some computers) where you insert an expansion card, connecting it to the system bus.

ExpressCard — A removable I/O card adhering to the PCMCIA standard. Modems and network adapters are common types of ExpressCards. ExpressCards support both the PCI Express and USB 2.0 standard.

Express Service Code — A numeric code located on a sticker on your Dell™ computer. Use the Express Service Code when contacting Dell for assistance. Express Service Code service may not be available in some countries.

extended display mode — A display setting that allows you to use a second monitor as an extension of your display. Also referred to as *dual display mode*.

extended PC Card — A PC Card that extends beyond the edge of the PC Card slot when installed.

F

Fahrenheit — A temperature measurement scale where 32° is the freezing point and 212° is the boiling point of water.

FBD — fully-buffered DIMM — A DIMM with DDR2 DRAM chips and an Advanced Memory Buffer (AMB) that speeds communication between the DDR2 SDRAM chips and the system.

FCC — Federal Communications Commission — A U.S. agency responsible for enforcing communications-related regulations that state how much radiation computers and other electronic equipment can emit.

fingerprint reader — A strip sensor that uses your unique fingerprint to authenticate your user identity to help secure your computer.

folder — A term used to describe space on a disk or drive where files are organized and grouped. Files in a folder can be viewed and ordered in various ways, such as alphabetically, by date, and by size.

format — The process that prepares a drive or disk for file storage. When a drive or disk is formatted, the existing information on it is lost.

FSB — front side bus — The data path and physical interface between the processor and RAM.

FTP — file transfer protocol — A standard Internet protocol used to exchange files between computers connected to the Internet.

G

G — gravity — A measurement of weight and force.

GB — gigabyte — A measurement of data storage that equals 1024 MB (1,073,741,824 bytes). When used to refer to hard drive storage, the term is often rounded to 1,000,000,000 bytes.

GHz — gigahertz — A measurement of frequency that equals one thousand million Hz, or one thousand MHz. The speeds for computer processors, buses, and interfaces are often measured in GHz.

graphics mode — A video mode that can be defined as x horizontal pixels by y vertical pixels by z colors. Graphics modes can display an unlimited variety of shapes and fonts.

GUI — graphical user interface — Software that interacts with the user by means of menus, windows, and icons. Most programs that operate on the Windows operating systems are GUIs.

H

hard drive — A drive that reads and writes data on a hard disk. The terms hard drive and hard disk are often used interchangeably.

heat sink — A metal plate on some processors that helps dissipate heat.

hibernate mode — A power management mode that saves everything in memory to a reserved space on the hard drive and then turns off the computer. When you restart the computer, the memory information that was saved to the hard drive is automatically restored.

HTTP — hypertext transfer protocol — A protocol for exchanging files between computers connected to the Internet.

Hyper-Threading — Hyper-Threading is an Intel technology that can enhance overall computer performance by allowing one physical processor to function as two logical processors, capable of performing certain tasks simultaneously.

Hz — hertz — A unit of frequency measurement that equals 1 cycle per second. Computers and electronic devices are often measured in kilohertz (kHz), megahertz (MHz), gigahertz (GHz), or terahertz (THz).

I

IC — integrated circuit — A semiconductor wafer, or chip, on which thousands or millions of tiny electronic components are fabricated for use in computer, audio, and video equipment.

IDE — integrated device electronics — An interface for mass storage devices in which the controller is integrated into the hard drive or CD drive.

IEEE 1394 — Institute of Electrical and Electronics Engineers, Inc. — A high-performance serial bus used to connect IEEE 1394-compatible devices, such as digital cameras and DVD players, to the computer.

infrared sensor — A port that allows you to transfer data between the computer and infrared-compatible devices without using a cable connection.

integrated — Usually refers to components that are physically located on the computer's system board. Also referred to as *built-in*.

I/O — input/output — An operation or device that enters and extracts data from your computer. Keyboards and printers are I/O devices.

I/O address — An address in RAM that is associated with a specific device (such as a serial connector, parallel connector, or expansion slot) and allows the processor to communicate with that device.

IrDA — Infrared Data Association — The organization that creates international standards for infrared communications.

IRQ — interrupt request — An electronic pathway assigned to a specific device so that the device can communicate with the processor. Each device connection must be

assigned an **IRQ**. Although two devices can share the same **IRQ** assignment, you cannot operate both devices simultaneously.

ISP — Internet service provider — A company that allows you to access its host server to connect directly to the Internet, send and receive e-mail, and access websites. The ISP typically provides you with a software package, user name, and access phone numbers for a fee.

K

Kb — kilobit — A unit of data that equals 1024 bits. A measurement of the capacity of memory integrated circuits.

KB — kilobyte — A unit of data that equals 1024 bytes but is often referred to as 1000 bytes.

key combination — A command requiring you to press multiple keys at the same time.

kHz — kilohertz — A measurement of frequency that equals 1000 Hz.

L

LAN — local area network — A computer network covering a small area. A LAN usually is confined to a building or a few nearby buildings. A LAN can be connected to another LAN over any distance through telephone lines and radio waves to form a wide area network (WAN).

LCD — liquid crystal display — The technology used by portable computer and flat-panel displays.

LED — light-emitting diode — An electronic component that emits light to indicate the status of the computer.

local bus — A data bus that provides a fast throughput for devices to the processor.

LPT — line print terminal — The designation for a parallel connection to a printer or other parallel device.

M

Mb — megabit — A measurement of memory chip capacity that equals 1024 Kb.

Mbps — megabits per second — One million bits per second. This measurement is typically used for transmission speeds for networks and modems.

MB — megabyte — A measurement of data storage that equals 1,048,576 bytes. 1 MB

equals 1024 KB. When used to refer to hard drive storage, the term is often rounded to 1,000,000 bytes.

MB/sec — megabytes per second — One million bytes per second. This measurement is typically used for data transfer ratings.

media bay — A bay that supports devices such as optical drives, a second battery, or a Dell TravelLite™ module.

memory — A temporary data storage area inside your computer. Because the data in memory is not permanent, it is recommended that you frequently save your files while you are working on them, and always save your files before you shut down the computer. Your computer can contain several different forms of memory, such as RAM, ROM, and video memory. Frequently, the word memory is used as a synonym for RAM.

memory address — A specific location where data is temporarily stored in RAM.

memory mapping — The process by which the computer assigns memory addresses to physical locations at start-up. Devices and software can then identify information that the processor can access.

memory module — A small circuit board containing memory chips, which connects to the system board.

MHz — megahertz — A measure of frequency that equals 1 million cycles per second. The speeds for computer processors, buses, and interfaces are often measured in MHz.

Mini PCI — A standard for integrated peripheral devices with an emphasis on communications such as modems and NICs. A Mini PCI card is a small external card that is functionally equivalent to a standard PCI expansion card.

Mini-Card — A small card designed for integrated peripherals, such as communication NICs. The Mini-Card is functionally equivalent to a standard PCI expansion card.

modem — A device that allows your computer to communicate with other computers over analog telephone lines. Three types of modems include: external, PC Card, and internal. You typically use your modem to connect to the Internet and exchange e-mail.

module bay — See *media bay*.

MP — megapixel — A measure of image resolution used for digital cameras.

ms — millisecond — A measure of time that equals one thousandth of a second. Access times of storage devices are often measured in ms.

N

network adapter — A chip that provides network capabilities. A computer may include a network adapter on its system board, or it may contain a PC Card with an adapter on it. A network adapter is also referred to as a *NIC* (network interface controller).

NIC — See *network adapter*.

notification area — The section of the Windows taskbar that contains icons for providing quick access to programs and computer functions, such as the clock, volume control, and print status. Also referred to as *system tray*.

ns — nanosecond — A measure of time that equals one billionth of a second.

NVRAM — nonvolatile random access memory — A type of memory that stores data when the computer is turned off or loses its external power source. NVRAM is used for maintaining computer configuration information such as date, time, and other system setup options that you can set.

O

optical drive — A drive that uses optical technology to read or write data from CDs, DVDs, or DVD+RWs. Example of optical drives include CD drives, DVD drives, CD-RW drives, and CD-RW/DVD combo drives.

P

parallel connector — An I/O port often used to connect a parallel printer to your computer. Also referred to as an *LPT port*.

partition — A physical storage area on a hard drive that is assigned to one or more logical storage areas known as logical drives. Each partition can contain multiple logical drives.

PC Card — A removable I/O card adhering to the PCMCIA standard. Modems and network adapters are common types of PC Cards.

PCI — peripheral component interconnect — PCI is a local bus that supports 32- and 64-bit data paths, providing a high-speed data path between the processor and devices such as video, drives, and networks.

PCI Express — A modification to the PCI interface that boosts the data transfer rate between the processor and the devices attached to it. PCI Express can transfer data at speeds from 250 MB/sec to 4 GB/sec. If the PCI Express chip set and the device are capable of different speeds, they will operate at the slower speed.

PCMCIA — Personal Computer Memory Card International Association — The organization that establishes standards for PC Cards.

PIO — programmed input/output — A method of transferring data between two devices through the processor as part of the data path.

pixel — A single point on a display screen. Pixels are arranged in rows and columns to create an image. A video resolution, such as 800 x 600, is expressed as the number of pixels across by the number of pixels up and down.

Plug-and-Play — The ability of the computer to automatically configure devices. Plug and Play provides automatic installation, configuration, and compatibility with existing hardware if the BIOS, operating system, and all devices are Plug and Play compliant.

POST — power-on self-test — Diagnostics programs, loaded automatically by the BIOS, that perform basic tests on the major computer components, such as memory, hard drives, and video. If no problems are detected during POST, the computer continues the start-up.

processor — A computer chip that interprets and executes program instructions. Sometimes the processor is referred to as the CPU (central processing unit).

PS/2 — personal system/2 — A type of connector for attaching a PS/2-compatible keyboard, mouse, or keypad.

PXE — pre-boot execution environment — A WfM (Wired for Management) standard that allows networked computers that do not have an operating system to be configured and started remotely.

R

RAID — redundant array of independent disks — A method of providing data redundancy. Some common implementations of RAID include RAID 0, RAID 1, RAID 5, RAID 10, and RAID 50.

RAM — random-access memory — The primary temporary storage area for program instructions and data. Any information stored in RAM is lost when you shut down your computer.

readme file — A text file included with a software package or hardware product. Typically, readme files provide installation information and describe new product enhancements or corrections that have not yet been documented.

read-only — Data and/or files you can view but cannot edit or delete. A file can have read-only status if:

- It resides on a physically write-protected floppy disk, CD, or DVD.

- It is located on a network in a directory and the system administrator has assigned rights only to specific individuals.

refresh rate — The frequency, measured in Hz, at which your screen's horizontal lines are recharged (sometimes also referred to as its *vertical frequency*). The higher the refresh rate, the less video flicker can be seen by the human eye.

resolution — The sharpness and clarity of an image produced by a printer or displayed on a monitor. The higher the resolution, the sharper the image.

RFI — radio frequency interference — Interference that is generated at typical radio frequencies, in the range of 10 kHz to 100,000 MHz. Radio frequencies are at the lower end of the electromagnetic frequency spectrum and are more likely to have interference than the higher frequency radiations, such as infrared and light.

ROM — read-only memory — Memory that stores data and programs that cannot be deleted or written to by the computer. ROM, unlike RAM, retains its contents after you shut down your computer. Some programs essential to the operation of your computer reside in ROM.

RPM — revolutions per minute — The number of rotations that occur per minute. Hard drive speed is often measured in rpm.

RTC — real time clock — Battery-powered clock on the system board that keeps the date and time after you shut down the computer.

RTCST — real-time clock reset — A jumper on the system board of some computers that can often be used for troubleshooting problems.

S

SAS — serial attached SCSI — A faster, serial version of the SCSI interface (as opposed to the original SCSI parallel architecture).

SATA — serial ATA — A faster, serial version of the ATA (IDE) interface.

ScanDisk — A Microsoft utility that checks files, folders, and the hard disk's surface for errors. ScanDisk often runs when you restart the computer after it has stopped responding.

SCSI — small computer system interface — A high-speed interface used to connect devices to a computer, such as hard drives, CD drives, printers, and scanners. The SCSI can connect many devices using a single controller. Each device is accessed by an individual identification number on the SCSI controller bus.

SDRAM — synchronous dynamic random-access memory — A type of DRAM that is synchronized with the optimal clock speed of the processor.

serial connector — An I/O port often used to connect devices such as a handheld

digital device or digital camera to your computer.

Service Tag — A bar code label on your computer that identifies your computer when you access Dell Support at support.dell.com or when you call Dell for customer service or technical support.

setup program — A program that is used to install and configure hardware and software. The **setup.exe** or **install.exe** program comes with most Windows software packages. *Setup program* differs from *system setup*.

shortcut — An icon that provides quick access to frequently used programs, files, folders, and drives. When you place a shortcut on your Windows desktop and double-click the icon, you can open its corresponding folder or file without having to find it first. Shortcut icons do not change the location of files. If you delete a shortcut, the original file is not affected. Also, you can rename a shortcut icon.

SIM — Subscriber Identity Module — A SIM card contains a microchip that encrypts voice and data transmissions. SIM cards can be used in phones or portable computers.

smart card — A card that is embedded with a processor and a memory chip. Smart cards can be used to authenticate a user on computers equipped for smart cards.

S/PDIF — Sony/Philips Digital Interface — An audio transfer file format that allows the transfer of audio from one file to another without converting it to and from an analog format, which could degrade the quality of the file.

standby mode — A power management mode that shuts down all unnecessary computer operations to save energy.

Strike Zone™ — Reinforced area of the platform base that protects the hard drive by acting as a dampening device when a computer experiences resonating shock or is dropped (whether the computer is on or off).

surge protectors — Prevent voltage spikes, such as those that may occur during an electrical storm, from entering the computer through the electrical outlet. Surge protectors do not protect against lightning strikes or against brownouts, which occur when the voltage drops more than 20 percent below the normal AC-line voltage level.

Network connections cannot be protected by surge protectors. Always disconnect the network cable from the network connector during electrical storms.

SVGA — super-video graphics array — A video standard for video cards and controllers. Typical SVGA resolutions are 800 x 600 and 1024 x 768.

The number of colors and resolution that a program displays depends on the capabilities of the monitor, the video controller and its drivers, and the amount of video memory installed in the computer.

S-video TV-out — A connector used to attach a TV or digital audio device to the computer.

SXGA — super-extended graphics array — A video standard for video cards and controllers that supports resolutions up to 1280 x 1024.

SXGA+ — super-extended graphics array plus — A video standard for video cards and controllers that supports resolutions up to 1400 x 1050.

system board — The main circuit board in your computer. Also known as the *motherboard*.

system setup — A utility that serves as an interface between the computer hardware and the operating system. System setup allows you to configure user-selectable options in the BIOS, such as date and time or system password. Unless you understand what effect the settings have on the computer, do not change the settings for this program.

T

TAPI — telephony application programming interface — Enables Windows programs to operate with a wide variety of telephony devices, including voice, data, fax, and video.

text editor — A program used to create and edit files that contain only text; for example, Windows Notepad uses a text editor. Text editors do not usually provide word wrap or formatting functionality (the option to underline, change fonts, and so on).

TPM — trusted platform module — A hardware-based security feature that when combined with security software enhances network and computer security by enabling features such as file and e-mail protection.

travel module — A plastic device designed to fit inside the module bay of a portable computer to reduce the weight of the computer.

U

UAC — user account control — Microsoft Windows Vista™ security feature that, when enabled, provides an added layer of security between user accounts and access to operating system settings.

UMA — unified memory allocation — System memory dynamically allocated to video.

UPS — uninterruptible power supply — A backup power source used when the electrical power fails or drops to an unacceptable voltage level. A UPS keeps a computer running for a limited amount of time when there is no electrical power. UPS systems typically provide surge suppression and may also provide voltage regulation. Small UPS systems provide battery power for a few minutes to enable you to shut

down your computer.

USB — universal serial bus — A hardware interface for a low-speed device such as a USB-compatible keyboard, mouse, joystick, scanner, set of speakers, printer, broadband devices (DSL and cable modems), imaging devices, or storage devices. Devices are plugged directly in to a 4-pin socket on your computer or in to a multi-port hub that plugs in to your computer. USB devices can be connected and disconnected while the computer is turned on, and they can also be daisy-chained together.

UTP — unshielded twisted pair — Describes a type of cable used in most telephone networks and some computer networks. Pairs of unshielded wires are twisted to protect against electromagnetic interference, rather than relying on a metal sheath around each pair of wires to protect against interference.

UXGA — ultra extended graphics array — A video standard for video cards and controllers that supports resolutions up to 1600 x 1200.

V

video controller — The circuitry on a video card or on the system board (in computers with an integrated video controller) that provides the video capabilities—in combination with the monitor—for your computer.

video memory — Memory that consists of memory chips dedicated to video functions. Video memory is usually faster than system memory. The amount of video memory installed primarily influences the number of colors that a program can display.

video mode — A mode that describes how text and graphics are displayed on a monitor. Graphics-based software, such as Windows operating systems, displays in video modes that can be defined as x horizontal pixels by y vertical pixels by z colors. Character-based software, such as text editors, displays in video modes that can be defined as x columns by y rows of characters.

video resolution — See *resolution*.

virus — A program that is designed to inconvenience you or to destroy data stored on your computer. A virus program moves from one computer to another through an infected disk, software downloaded from the Internet, or e-mail attachments. When an infected program starts, its embedded virus also starts.

A common type of virus is a boot virus, which is stored in the boot sectors of a floppy disk. If the floppy disk is left in the drive when the computer is shut down and then turned on, the computer is infected when it reads the boot sectors of the floppy disk expecting to find the operating system. If the computer is infected, the boot virus may replicate itself onto all the floppy disks that are read or written in that computer until the virus is eradicated.

V — volt — The measurement of electric potential or electromotive force. One V appears across a resistance of 1 ohm when a current of 1 ampere flows through that resistance.

W

W — watt — The measurement of electrical power. One W is 1 ampere of current flowing at 1 volt.

WHr — watt-hour — A unit of measure commonly used to indicate the approximate capacity of a battery. For example, a 66-WHr battery can supply 66 W of power for 1 hour or 33 W for 2 hours.

wallpaper — The background pattern or picture on the Windows desktop. Change your wallpaper through the Windows Control Panel. You can also scan in your favorite picture and make it wallpaper.

WLAN — wireless local area network. A series of interconnected computers that communicate with each other over the air waves using access points or wireless routers to provide Internet access.

write-protected — Files or media that cannot be changed. Use write-protection when you want to protect data from being changed or destroyed. To write-protect a 3.5-inch floppy disk, slide its write-protect tab to the open position.

WWAN — wireless wide area network. A wireless high-speed data network using cellular technology and covering a much larger geographic area than WLAN.

WXGA — wide-aspect extended graphics array — A video standard for video cards and controllers that supports resolutions up to 1280 x 800.

X

XGA — extended graphics array — A video standard for video cards and controllers that supports resolutions up to 1024 x 768.

Z

ZIF — zero insertion force — A type of socket or connector that allows a computer chip to be installed or removed with no stress applied to either the chip or its socket.

Zip — A popular data compression format. Files that have been compressed with the Zip format are called Zip files and usually have a filename extension of **.zip**. A special kind of zipped file is a self-extracting file, which has a filename extension of **.exe**. You can unzip a self-extracting file by double-clicking it.

Zip drive — A high-capacity floppy drive developed by Iomega Corporation that uses 3.5-inch removable disks called Zip disks. Zip disks are slightly larger than regular floppy disks, about twice as thick, and hold up to 100 MB of data.

