

lenovo

ThinkServer TD230
Installation and User Guide



ThinkThink**ThinkServer**Think

Machine Types: 1027, 1029, 1039, and 1040



ThinkServer TD230 Installation and User Guide

Machine Types: 1027, 1029, 1039, and 1040

Note:

Before using this information and the product it supports, be sure to read and understand the following:

- The *Important Notices* that came with your product
- The *Safety Information* and the *Warranty and Support Information* on the *ThinkServer Documentation DVD* that came with your product
- Appendix B “Notices” on page 129

Third Edition (February 2011)

© Copyright Lenovo 2010, 2011.

LENOVO products, data, computer software, and services have been developed exclusively at private expense and are sold to governmental entities as commercial items as defined by 48 C.F.R. 2.101 with limited and restricted rights to use, reproduction and disclosure.

LIMITED AND RESTRICTED RIGHTS NOTICE: If products, data, computer software, or services are delivered pursuant a General Services Administration “GSA” contract, use, reproduction, or disclosure is subject to restrictions set forth in Contract No. GS-35F-05925.

Contents

Safety information	v	Installing or removing the ThinkServer TD230 SATA RAID 5 Upgrade	58
Chapter 1. General information.	1	Installing or removing the ThinkServer 9240-8i RAID 5 Upgrade Key	60
Introduction	1	Installing or removing the ThinkServer Remote Management Module 3	62
Notices and statements in the document	1	Installing, removing, or replacing hardware devices	69
Related documentation	2	Removing or installing the ThinkServer 9240-8i RAID 0/1 Adapter	69
Chapter 2. Server setup road map	3	Removing or installing the heat sink and fan assembly	71
Chapter 3. Product overview	5	Removing or installing a front fan	77
What is included with your server	5	Removing or installing the rear fan	82
Features and specifications.	5	Removing or installing the microprocessor	86
Software programs	7	Replacing the system board battery	89
EasyStartup	7	Completing the parts replacement	90
EasyManage.	7	Installing the server cover	91
Reliability, availability, and serviceability.	7	Connecting the cables	91
Chapter 4. Locating parts, controls, LEDs, and connectors	9	Turning on the server	91
Front view	9	Updating the server configuration	91
Rear view.	12	Turning off the server	92
Hot-swap hard disk drive status LEDs	13	Connecting external devices	92
LEDs for the Ethernet connectors	13	Chapter 6. Configuring the server	95
Locating server components	14	Using the Setup Utility program	95
Locating parts on the system board	15	Starting the Setup Utility program	95
Locating diagnostic LEDs on the system board	16	Introduction of the BIOS items.	96
Jumper block settings.	17	Using passwords	101
Locating connectors on the hot-swap hard disk drive backplanes.	18	RAID controllers	102
Chapter 5. Installing, removing, or replacing hardware	21	Using the ThinkServer EasyStartup program	103
Guidelines	21	Before you use the EasyStartup DVD	104
Basic guidelines	21	Setup and configuration	104
System reliability guidelines.	22	Configuring RAID	105
Handling static-sensitive devices	22	Typical operating system installation	105
Working inside the server with the power on	23	Configuring the onboard SATA software RAID	106
Removing the server cover	23	RAID information	106
Removing and reinstalling the front bezel	25	Starting the Intel Embedded Server RAID Technology II program	106
Locking or unlocking the hard disk drive side door.	26	Creating a RAID volume	106
Installing, removing, or replacing optional hardware devices	29	Initializing the RAID volume	107
Installing or removing a memory module.	29	Deleting the RAID volume	108
Removing or installing internal drives	32	Rebuilding the RAID volume	108
Installing or removing a PCI card.	53	Checking the RAID 1 volume consistency	108
Installing or removing the Ethernet card	56	Configuring the Gigabit Ethernet controller.	109
		Updating the firmware.	109
		Using the EasyUpdate Firmware Updater program	109

Installing the ThinkServer EasyManage program	110
Chapter 7. Troubleshooting.	111
Troubleshooting tables	111
DVD drive problems	111
General problems	112
Hard disk drive problems	112
Intermittent problems	112
Keyboard, mouse, or pointing-device problems	113
Memory problems	113
Microprocessor problems	114
Monitor problems	115
Optional-device problems	116
Power problems	117
Serial port problems	118
Software problems	119
Universal Serial Bus (USB) port problems	120
Solving power problems	120
Solving Ethernet controller problems	120
Solving undetermined problems	121
Event logs	122
System event log	122
Diagnostic programs and messages	122
Diagnostic LEDs on the front panel and the system board	123

Appendix A. Getting help and technical assistance 125

Before you call	125
Using the documentation	125
Getting help and information from the World Wide Web	125
Lenovo Support Web site	126
Calling for service	126
Using other services	127
Purchasing additional services	127
Lenovo product service information for Taiwan	127

Appendix B. Notices 129

Trademarks	130
Important notes	130
Product recycling and disposal	130
Particulate contamination	131
Turkish statement of compliance	132
Battery return program	132
German Ordinance for Work gloss statement	133
Electronic emission notices	134
Federal Communications Commission (FCC) Statement	134

Index. 137

Safety information

Before installing this product, read the Safety Information.

قبل تركيب هذا المنتج، يجب قراءة الملاحظات الأمنية

Antes de instalar este produto, leia as Informações de Segurança.

Prije instalacije ovog produkta obavezno pročitajte Sigurnosne Upute.

Před instalací tohoto produktu si přečtěte příručku bezpečnostních instrukcí.

Læs sikkerhedsforskrifterne, før du installerer dette produkt.

Lees voordat u dit product installeert eerst de veiligheidsvoorschriften.

Ennen kuin asennat tämän tuotteen, lue turvaohjeet kohdasta Safety Information.

Avant d'installer ce produit, lisez les consignes de sécurité.

Vor der Installation dieses Produkts die Sicherheitshinweise lesen.

Πριν εγκαταστήσετε το προϊόν αυτό, διαβάστε τις πληροφορίες ασφάλειας (safety information).

לפני שתתקינו מוצר זה, קראו את הוראות הבטיחות.

A termék telepítése előtt olvassa el a Biztonsági előírásokat!

Prima di installare questo prodotto, leggere le Informazioni sulla Sicurezza.

製品の設置の前に、安全情報をお読みください。

본 제품을 설치하기 전에 안전 정보를 읽으십시오.

Пред да се инсталира овој продукт, прочитајте информацијата за безбедност.

Les sikkerhetsinformasjonen (Safety Information) før du installerer dette produktet.

Przed zainstalowaniem tego produktu, należy zapoznać się z książką "Informacje dotyczące bezpieczeństwa" (Safety Information).

Antes de instalar este produto, leia as Informações sobre Segurança.

Перед установкой продукта прочтите инструкции по технике безопасности.

Pred inštaláciou tohto zariadenia si pečítajte Bezpečnostné predpisy.

Pred namestitvijo tega proizvoda preberite Varnostne informacije.

Antes de instalar este producto, lea la información de seguridad.

Läs säkerhetsinformationen innan du installerar den här produkten.

在安装本产品之前，请仔细阅读 Safety Information（安全信息）。

安裝本產品之前，請先閱讀「安全資訊」。

Important: Each caution and danger statement in this document is labeled with a number. This number is used to cross reference an English-language caution or danger statement with translated versions of the caution or danger statement in the *Safety Information* manual. For example, if a caution statement is labeled “Statement 1,” translations for this caution statement are in the *Safety Information* manual under “Statement 1.”

Be sure to read and understand all caution and danger statements in this document before you perform the procedures. Read and understand any additional safety information that comes with the server or an optional device before you install, remove, or replace the device.

Statement 1



DANGER

Electrical current from power, telephone, and communication cables is hazardous.

To avoid a shock hazard:

- **Do not connect or disconnect any cables or perform installation, maintenance, or reconfiguration of this product during an electrical storm.**
- **Connect all power cords to a properly wired and grounded electrical outlet.**
- **Connect to properly wired outlets any equipment that will be attached to this product.**
- **When possible, use one hand only to connect or disconnect signal cables.**
- **Never turn on any equipment when there is evidence of fire, water, or structural damage.**
- **Disconnect the attached power cords, telecommunications systems, networks, and modems before you open the device covers, unless instructed otherwise in the installation and configuration procedures.**
- **Connect and disconnect cables as described in the following table when installing, moving, or opening covers on this product or attached devices.**

To Connect:

1. Turn everything OFF.
2. First, attach all cables to devices.
3. Attach signal cables to connectors.
4. Attach power cords to outlet.
5. Turn device ON.

To Disconnect:

1. Turn everything OFF.
2. First, remove power cords from outlet.
3. Remove signal cables from connectors.
4. Remove all cables from devices.

Statement 2



CAUTION:

When replacing the lithium battery, use only the battery recommended by the manufacturer. If your system has a module containing a lithium battery, replace it only with the same module type made by the same manufacturer. The battery contains lithium and can explode if not properly used, handled, or disposed of. *Do not:*

- Throw or immerse into water
- Heat to more than 100°C (212°F)
- Repair or disassemble

Dispose of the battery as required by local ordinances or regulations.

Statement 3



CAUTION:

When laser products (such as CD-ROMs, DVD drives, fiber optic devices, or transmitters) are installed, note the following:

- Do not remove the covers. Removing the covers of the laser product could result in exposure to hazardous laser radiation. There are no serviceable parts inside the device.
- Use of controls or adjustments or performance of procedures other than those specified herein might result in hazardous radiation exposure.



DANGER

Some laser products contain an embedded Class 3A or Class 3B laser diode. Note the following.

Laser radiation when open. Do not stare into the beam, do not view directly with optical instruments, and avoid direct exposure to the beam.

Statement 4

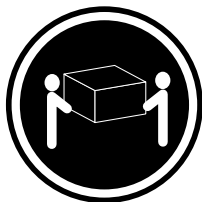

≥ 18 kg (39.7 lb)



≥ 32 kg (70.5 lb)

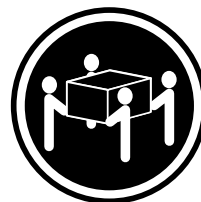

≥ 55 kg (121.2 lb)

CAUTION:

Use safe practices when lifting.

Statement 5



CAUTION:

The power control button on the device and the power switch on the power supply do not turn off the electrical current supplied to the device. The device also might have more than one power cord. To remove all electrical current from the device, ensure that all power cords are disconnected from the power source.

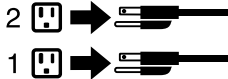

Statement 8



CAUTION:

Never remove the cover on a power supply or any part that has the following label attached.



Hazardous voltage, current, and energy levels are present inside any component that has this label attached. There are no serviceable parts inside these components. If you suspect a problem with one of these parts, contact a service technician.

Statement 11



CAUTION:

The following label indicates sharp edges, corners, or joints nearby.



Statement 12



CAUTION:

The following label indicates a hot surface nearby.



Statement 13



 **DANGER**

Overloading a branch circuit is potentially a fire hazard and a shock hazard under certain conditions. To avoid these hazards, ensure that your system electrical requirements do not exceed branch circuit protection requirements. Refer to the information that is provided with your device for electrical specifications.

Statement 15



CAUTION:

Make sure that the rack is secured properly to avoid tipping when the server unit is extended.

Statement 17



CAUTION:

The following label indicates moving parts nearby.



Statement 26



CAUTION:

Do not place any object on top of rack-mounted devices.



Chapter 1. General information

This chapter provides some general information about your server.

This chapter contains the following topics:

- “Introduction” on page 1
- “Notices and statements in the document” on page 1
- “Related documentation” on page 2

Introduction

This *Installation and User Guide* is for your Lenovo® ThinkServer® TD230 server (machine types 1027, 1029, 1039, and 1040). This document contains the following information:

- Setting up and cabling the server
- Starting and configuring the server
- Installing options and replacing customer replaceable units (CRUs)
- Solving problems

The server comes with the *ThinkServer EasyStartup* DVD to help you configure the hardware, install device drivers, and install the operating system.

The server comes with a limited warranty. For information about the terms of the warranty and getting service and assistance, see the *Warranty and Support Information* on the *ThinkServer Documentation DVD* that comes with your server.

To obtain the most up-to-date information about the server and other Lenovo products, go to:
<http://www.lenovo.com/thinkserver>

Record information about the server in the following table. You will need these information when you register the server with Lenovo.

Product name	ThinkServer TD230
Machine type	1027, 1029, 1039, or 1040
Model number	_____
Serial number	_____

The model number and serial number are on labels on the top or on the bottom of the server.

Notices and statements in the document

The caution and danger statements that appear in this document are also in the multilingual *Safety Information*. Each caution and danger statement in this document is labeled with a number. This number is used to cross reference an English-language caution or danger statement with translated versions of the caution or danger statement in the *Safety Information*. See “Related documentation” on page 2 for detailed information about how to get the various documentation for your server.

The following notices and statements are used in this document:

- **Note:** These notices provide important tips, guidance, or advice.
- **Important:** These notices provide information or advice that might help you avoid problems or inconvenient situations.
- **Attention:** These notices indicate potential damage to programs, devices, or data. An attention notice is placed just before the instruction or situation in which damage could occur.
- **Caution:** These statements indicate situations that can be potentially hazardous to you. A caution statement is placed just before the description of a potentially hazardous procedure step or situation.
- **Danger:** These statements indicate situations that can be potentially lethal or extremely hazardous to you. A danger statement is placed just before the description of a potentially lethal or extremely hazardous procedure step or situation.

Related documentation

The Lenovo *ThinkServer Documentation DVD*, which comes with your server, contains documentation for the server in Portable Document Format (PDF). To view the documentation on the *ThinkServer Documentation DVD*, you need to have the Adobe Reader 5.0 program or later installed, or the xpdf, which comes with Linux® operating systems.

The following table provides information about the general descriptions of the various documentation provided with your server and how to obtain all these documentation.

Table 1. Related documentation for the server

Documentation	Description	Location
Hardware Maintenance Manual	This document provides diagnostic information, parts listing, replacement procedures for all CRUs, and replacement procedures for other field replaceable units (FRUs) replaced by trained service personnel.	This document is in English and posted on the Lenovo Support Web site at http://www.lenovo.com/support .
Important Notices	This document includes safety and legal notices that you are expected to read before using the server.	This document is printed out and provided in server packaging.
Read Me First	This document directs you to the <i>ThinkServer Documentation DVD</i> for complete warranty and support information.	This document is printed out and provided in server packaging.
Safety Information	This document includes translations of all safety statements used in the ThinkServer documentation.	Available on the <i>ThinkServer Documentation DVD</i>
Warranty and Support Information	This document includes the warranty statement and information about how to contact Lenovo Support.	Available on the <i>ThinkServer Documentation DVD</i>
ThinkServer Remote Management User Guide	If you have installed a ThinkServer Remote Management Module 3 in the server, use this user guide to help you do the related configurations.	Available on the <i>ThinkServer Documentation DVD</i>
ThinkServer MegaRAID SAS Software User Guide	If you have installed a ThinkServer 9240-8i RAID 0/1 Adapter in the server, use this user guide to help you configure RAID using the ThinkServer 9240-8i RAID 0/1 Adapter.	Available on the <i>ThinkServer Documentation DVD</i>
Note: You can obtain all the documentation in PDF for your server from the Lenovo Support Web site at http://www.lenovo.com/support .		

Chapter 2. Server setup road map

This chapter provides a general road map to guide you through setting up your server.

The server setup procedure varies depending on the configuration of the server when it was delivered. In some cases, the server is fully configured and you just need to connect the server to the network and an electrical outlet, and then you can turn on the server. In other cases, the server needs to have hardware features installed, requires hardware and firmware configuration, and requires the operating system to be installed.

Table 2. Server setup road map

Task	Where to find the information
Unpack	"What is included with your server" on page 5
Install hardware	Chapter 5 "Installing, removing, or replacing hardware" on page 21
Connect the Ethernet cable and power cord	"Rear view" on page 12
Turn on the server to verify operation	"Turning on the server" on page 91
Review the BIOS settings and customize as needed	"Starting the Setup Utility program" on page 95
Configure RAID	"RAID controllers" on page 102
Check for firmware updates	"Using the EasyUpdate Firmware Updater program" on page 109
Install operating system and basic drivers	"Using the ThinkServer EasyStartup program" on page 103
Install any additional drivers needed for added features	Refer to the instructions that came with the hardware option.
Configure Ethernet settings in the operating system	See the operating system help. This step is not required if the operating system was installed using the ThinkServer EasyStartup program.
Install remote management applications	"Installing the ThinkServer EasyManage program" on page 110
Install applications	Refer to the documentation that comes with the applications that you want to install.

Chapter 3. Product overview

This chapter provides information about the server package, features, specifications, and software programs.

What is included with your server

The ThinkServer TD230 server package includes the server, a power cord, documentation, the *ThinkServer Documentation DVD*, and software media.

Features and specifications

The following table provides information about the features and specifications of the server. Depending on the server model, some features might not be available, or some specifications might not apply. For information about your specific model, use the Setup Utility program. See “Using the Setup Utility program” on page 95.

Table 3. Features and specifications

<p>Microprocessor(s): Supports up to two Intel® Xeon® dual-core, quad-core, or hex-core microprocessors (internal cache size varies by model type) For the specific type and speed information about the microprocessor, use the Setup Utility program. See “Using the Setup Utility program” on page 95. For a list of supported microprocessors, go to http://www.lenovo.com/thinkserver and click Options under the Products tab.</p> <p>Large system-memory capacity:</p> <ul style="list-style-type: none"> • Supports up to eight memory modules • Minimum system memory: 2 GB • Maximum system memory: 32 GB (each memory slot with one 4 GB memory module installed) • Memory slots: Eight dual inline memory module (DIMM) slots • Types: 1333 MHz, DDR3 registered SDRAM DIMMs • Features: <ul style="list-style-type: none"> – Error Checking and Correcting (ECC) – Mirroring – Demand Scrub and Patrol Scrub • Supports 2 GB and 4 GB registered DIMMs • Numbers of DIMMs supported: <ul style="list-style-type: none"> – One, two, or four DIMMs if one microprocessor installed – Two, four, six, or eight DIMMs if two microprocessors installed <p>Integrated video controller: The server comes with an onboard high-performance graphics controller that supports high resolutions and includes many performance-enhancing features for the operating-system environment.</p> <ul style="list-style-type: none"> • 64 MB memory, 32 MB for video memory cache 	<p>Optical drive:</p> <ul style="list-style-type: none"> • SATA DVD/RW <p>Hard disk drive expansion bays (depending on model type):</p> <p>Supports up to four 3.5-inch Serial Advanced Technology Attachment (SATA) or SAS hot-swap hard disk drives Supports up to five 3.5-inch SATA non-hot-swap hard disk drives</p> <p>Large data-storage capacity and hot-swap capability</p> <p>Some server models support up to four 3.5-inch hot-swap hard disk drives. With the hot-swap feature, you can add, remove, or replace hard disk drives without turning off the server.</p> <p>Expansion slots (depending on model type):</p> <ul style="list-style-type: none"> • One Peripheral Component Interconnect (PCI) card slot • One PCI Express x4 card slot • Three PCI Express x8 card slots • One remote management module 3 connector <p>Power supply:</p> <p>625-watt power supply</p> <p>System fans:</p> <ul style="list-style-type: none"> • Two front system fans (system fan 2 for microprocessor 1 area and system fan 1 for microprocessor 2 area) • One rear system fan <p>RAID controllers:</p> <p>The server supports the onboard SATA software RAID and an installed SAS RAID card (ThinkServer 9240-8i RAID 0/1 Adapter), which are required for you to use the hot-swap SATA or SAS hard disk drives and to create the RAID configurations.</p> <ul style="list-style-type: none"> • Onboard ICH10R SATA controller • ThinkServer 9240-8i RAID 0/1 Adapter
---	---

Table 3. Features and specifications (continued)

<p>Integrated functions:</p> <ul style="list-style-type: none"> • Ethernet controllers (The server comes with two integrated Gigabit Ethernet controllers, which support connection to 10 Mbps, 100 Mbps, or 1000 Mbps network. For more information, see “Configuring the Gigabit Ethernet controller” on page 109.) • One serial port • One Video Graphics Array (VGA) monitor connector • Six Universal Serial Bus (USB) connectors (two front and four rear) • Two RJ-45 Ethernet connectors on the rear panel • Eight diagnostic LEDs <p>Intelligent Platform Management Interface (IPMI) 2.0</p> <p>The command-line interface provides direct access to server management functions through the IPMI 2.0 protocol. Use the command-line interface to issue commands to control the server power, view system information, and identify the server. You can also save one or more commands as a text file and run the file as a script.</p> <p>ThinkServer RMM3 System Management Card (Optional)</p>	<p>Size:</p> <ul style="list-style-type: none"> • Height: 470 mm (18.5 inches) • Width: 210 mm (8.27 inches) • Depth: 510 mm (20.1 inches) • Maximum weight with package: 26.2 kg (57.76 lb) when fully configured • Maximum weight without package: 22.3 kg (49.2 lb) when fully configured <p>Electrical input</p> <ul style="list-style-type: none"> • Input voltage: <ul style="list-style-type: none"> – Low range: <ul style="list-style-type: none"> Minimum: 100 V ac Maximum: 127 V ac Input frequency range: 50 to 60 Hz – High range: <ul style="list-style-type: none"> Minimum: 200 V ac Maximum: 240 V ac Input frequency range: 50 to 60 Hz
--	---

Software programs

Lenovo provides software to help get your server up and running.

EasyStartup

The ThinkServer EasyStartup program simplifies the process of configuring RAID and installing supported Microsoft® Windows® and Linux operating systems and device drivers on your server. The EasyStartup program is provided with your server on the *ThinkServer EasyStartup* DVD. The DVD is self-starting (bootable). The user guide for the EasyStartup program is on the DVD and can be accessed directly from the program interface. For additional information, see “Using the ThinkServer EasyStartup program” on page 103.

EasyManage

The ThinkServer EasyManage Agent enables this server to be managed by the centralized console of an EasyManage Core Server over the network. The ThinkServer EasyManage Agent is supported on 32-bit and 64-bit Windows, Red Hat, and SUSE operating systems.

Reliability, availability, and serviceability

Reliability, availability, and serviceability (hereafter referred to as RAS) are three important server design features. The RAS features help you to ensure the integrity of the data stored on the server, the availability of the server when you need it, and the ease with which you can diagnose and correct problems.

The server has the following RAS features:

- Advanced Configuration and Power Interface (ACPI)
- Advanced Desktop Management Interface (DMI)
- Automatic memory downsizing on error detection

- Automatic restart on non-maskable interrupt (NMI)
- Availability of microcode level
- Built-in, menu-driven setup, system configuration, and RAID configuration
- Built-in monitoring for fan, temperature, and voltage
- Cooling fans with speed-sensing capability
- ECC DDR3 SDRAM with Serial Presence Detect (SPD)
- Error codes and messages to help you identify problems
- Generating error logs for the power-on self-test (POST) failures
- Hot-swap SAS hard disk drives
- Integrated Ethernet controllers
- Intelligent Platform Management Interface (IPMI) 2.0
- Power-on self-test (POST)
- Standby voltage for system-management features and monitoring
- System-error light-emitting diode (LED) on the front panel
- Vital product data (VPD), including the serial number information and replacement part numbers, stored in the nonvolatile memory for easier remote maintenance

Chapter 4. Locating parts, controls, LEDs, and connectors

This chapter provides information to help you locate your server parts, controls, light-emitting diodes (LEDs), and connectors.

Front view

Figure 1 “Front view of the server” on page 9 shows the LEDs and parts on the front of the server.

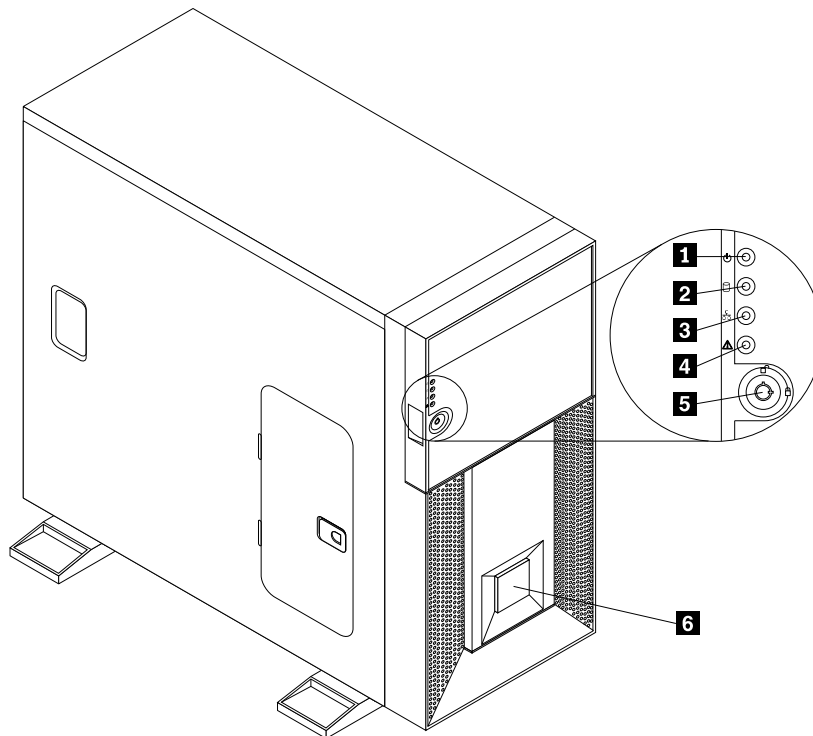

Figure 1. Front view of the server

- | | |
|-------------------------------------|----------------------------|
| 1 Power LED | 4 System status LED |
| 2 Hard disk drive status LED | 5 Front door lock |
| 3 Ethernet status LED | 6 Logo plate |

You can open the front door with the key to locate controls, LEDs, connectors, and other parts on the front panel.

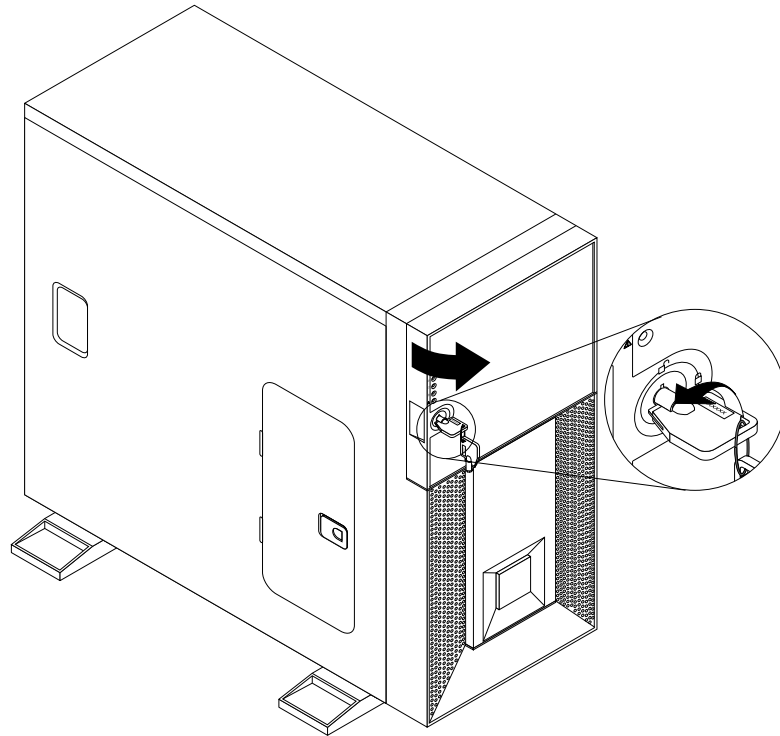

Figure 2. Opening the front door

Figure 3 “Front view of the server (with the front door open)” on page 11 shows the controls, LEDs, connectors, and other parts on the front panel after you open the front door.

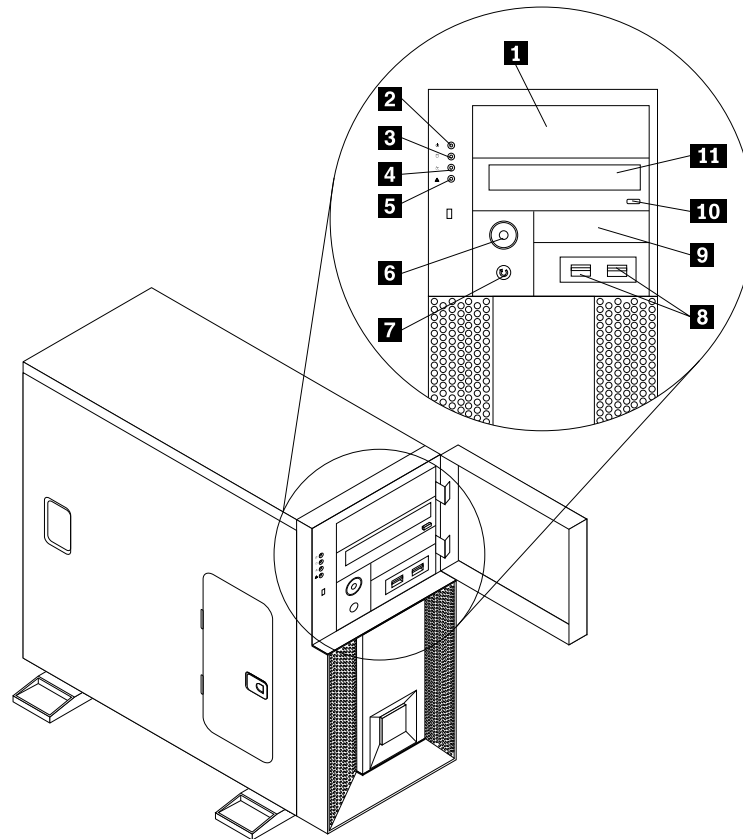

Figure 3. Front view of the server (with the front door open)

- 1** 5.25-inch drive bay
- 2** Power LED
- 3** Hard disk drive status LED
- 4** Ethernet status LED
- 5** System status LED
- 6** Power button
- 7** Reset button
- 8** USB connectors (2)
- 9** 3.5-inch drive bay
- 10** Optical drive eject/close button
- 11** Optical drive

The following table describes the various meanings of the status LEDs on the front panel of your server.

Table 4. Meanings of the status LEDs on the front panel

LED	State	Color	Description
Power LED	On	Green	The server is on.
	Blinking	Green	The server is in sleep mode.
	Off	Off	The server is off.
Hard disk drive status LED	Off	Off	The hard disk drive is not active.
	Blinking	Red	The hard disk drive is active and data is being transferred.

Table 4. Meanings of the status LEDs on the front panel (continued)

LED	State	Color	Description
Ethernet status LED	On	Green	The server is linked to a local area network (LAN).
	Blinking	Green	The LAN is active and data is being transferred.
	Off	Off	The server is not linked to a LAN.
System status LED	On	Amber	The system has error(s) and alarm(s).
	On	Green	The system is booted and ready.

Rear view

Figure 4 “Rear view of the server” on page 12 shows the locations of the connectors and parts on the rear of the server.

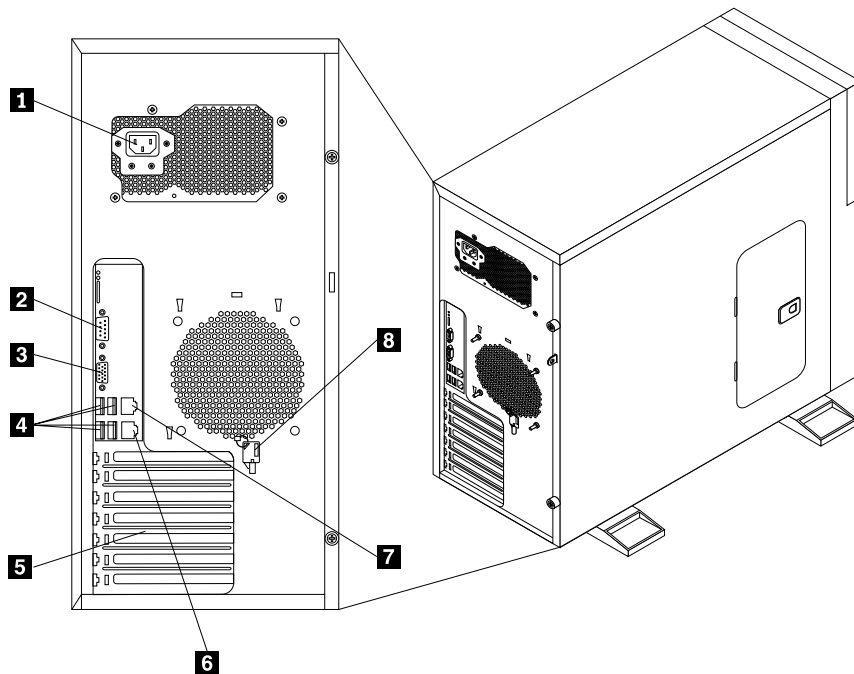

Figure 4. Rear view of the server

- | | |
|--------------------------------|---|
| 1 Power cord connector | 5 PCI card zone |
| 2 Serial port | 6 Ethernet connector 2 |
| 3 VGA monitor connector | 7 Ethernet connector 1 |
| 4 USB connectors (4) | 8 Front door key (cut the plastic clip to get the key) |

Connector	Description
Ethernet connector	Used to attach an Ethernet cable for a LAN.
Power cord connector	Used to connect the power cord.
Serial port	Used to attach a device that uses a 9-pin serial port.

Connector	Description
USB connector	Used to attach a device that uses a USB connector, such as a USB printer, a USB keyboard, or a USB mouse. If the USB connectors on your server are not enough for you to connect all your USB devices, you can purchase a USB hub, which you can use to connect additional USB devices.
VGA monitor connector	Used to attach a VGA monitor or other devices that use a VGA monitor connector.

Hot-swap hard disk drive status LEDs

For server models with hot-swap hard disk drives, each hot-swap hard disk drive also has two status LEDs on the front.

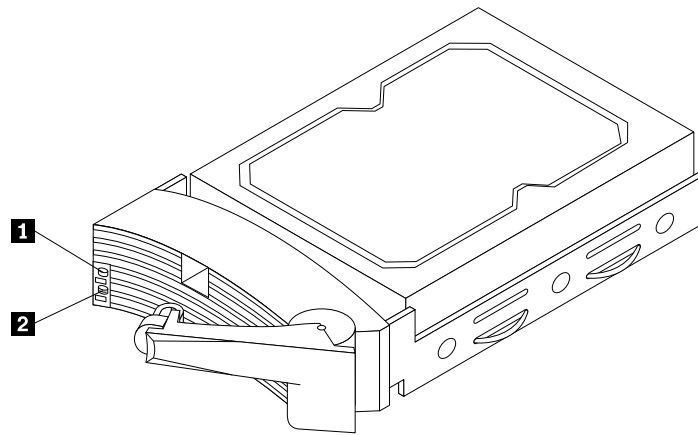

Figure 5. Hot-swap hard disk drive status LEDs

Table 5. Hot-swap hard disk drive status LEDs

Hot-swap hard disk drive status LED	State	Description
1 Hot-swap hard disk drive present LED	On	The hot-swap hard disk drive is present.
	Off	The hot-swap hard disk drive is not present.
2 Hot-swap hard disk drive activity LED	On	The hot-swap hard disk drive is active.
	Off	The hot-swap hard disk drive is not active.

LEDs for the Ethernet connectors

The Ethernet 1 and Ethernet 2 connectors have two status LEDs that indicate the LAN connection and activity of the connection.

Table 6. Ethernet LEDs

LED	State	Color	Description
RJ-45 Linkage and Activity (left)	On	Green	10/100/1000 Mb linked
	Blinking	Green	10/100/1000 Mb activity
	Off	Off	No LAN connection.

Table 6. Ethernet LEDs (continued)

LED	State	Color	Description
RJ-45 Linkage and Activity (right)	On	Amber	1000 Mb linked and active
	On	Green	100 Mb linked and active
	Off	Off	10 Mb mode or no LAN connection.

Locating server components

Figure 6 “Server component locations (side view without the server cover)” on page 14 shows the locations of the major components in your server. To remove the server cover and gain access to the inside of the server, see “Removing the server cover” on page 23.

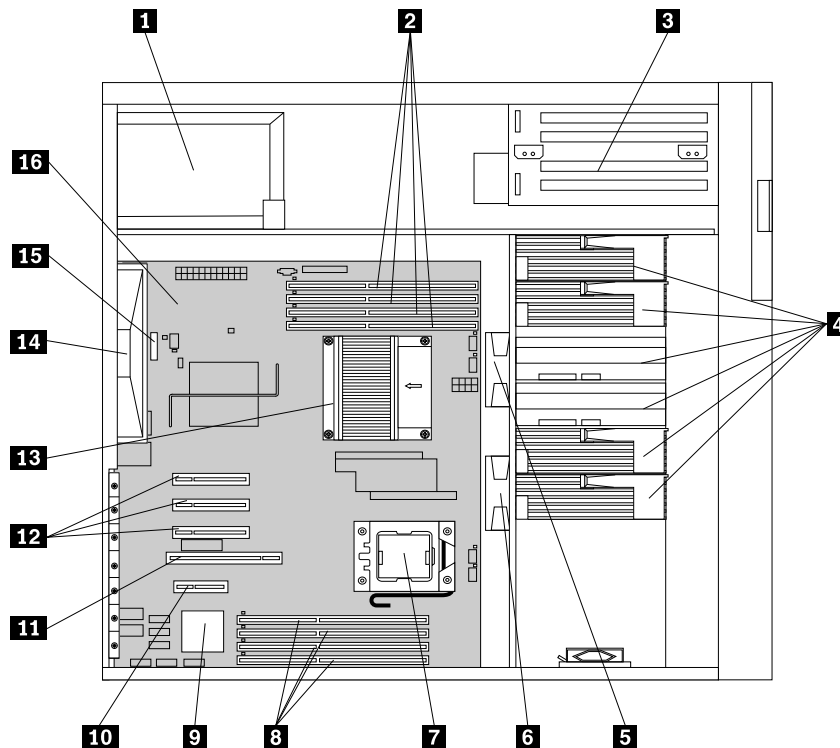

Figure 6. Server component locations (side view without the server cover)

- | | |
|---|--|
| 1 Power supply assembly | 9 Onboard ICH10R SATA RAID controller |
| 2 Memory slots for microprocessor 1 (some slots might with installed memory modules) | 10 PCI Express x4 slot |
| 3 Optical drive | 11 PCI card slot |
| 4 Hard disk drive zone* | 12 PCI Express x8 slots (3) |
| 5 System fan 2 | 13 Heat sink and fan assembly (microprocessor 1 underneath) |
| 6 System fan 1 | 14 Rear fan (system fan 3) |
| 7 Microprocessor 2 socket (the second microprocessor is optional) | 15 System board battery |

8 Memory slots for microprocessor 2 (some slots might with installed memory modules)

16 System board

Note: * denotes that this illustration only shows the server models with four hot-swap hard disk drives. There are also server models that support up to five non-hot-swap hard disk drives.

Locating parts on the system board

Figure 7 “Locating major parts on the system board” on page 15 shows the locations of the major parts on the system board.

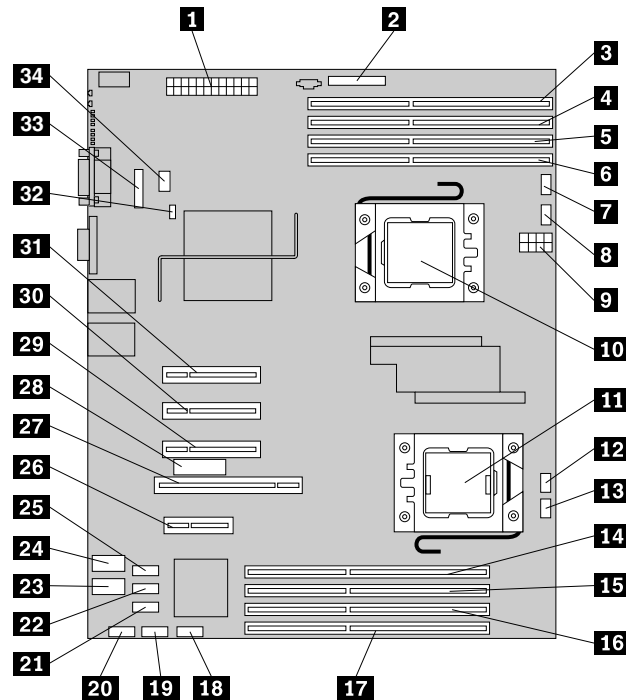

Figure 7. Locating major parts on the system board

1 Main power connector

2 Front panel connector

3 Memory slot - microprocessor 1 DIMM channel B1 (CPU1 DIMM CHB1)

4 Memory slot (CPU1 DIMM CHB2)

5 Memory slot (CPU1 DIMM CHA1)

6 Memory slot (CPU1 DIMM CHA2)

7 System fan 2 connector

8 Microprocessor 1 heat sink and fan assembly connector

9 Microprocessor power connector

10 Microprocessor 1

11 Microprocessor 2 socket (the second microprocessor is optional)

18 SATA connector 0

19 SATA connector 1

20 SATA connector 2

21 SATA connector 3

22 SATA connector 4

23 Internal dual-port USB 2.0 connector (ports 0-1)

24 Internal dual-port USB 2.0 connector (ports 2-3)

25 SATA connector 5

26 PCI Express x4 slot

27 PCI card slot

28 Remote management module 3 (RMM3) connector

- 12** Microprocessor 2 heat sink and fan assembly connector
- 13** System fan 1 connector
- 14** Memory slot (CPU2 DIMM CHD2)
- 15** Memory slot (CPU2 DIMM CHD1)
- 16** Memory slot (CPU2 DIMM CHE2)
- 17** Memory slot (CPU2 DIMM CHE1)
- 29** PCI Express x8 slot
- 30** PCI Express x8 slot
- 31** PCI Express x8 slot
- 32** SATA key connector for the ThinkServer TD230 SATA RAID 5 Upgrade (see “Installing or removing the ThinkServer TD230 SATA RAID 5 Upgrade” on page 58)
- 33** System board battery
- 34** System fan 3 connector

Locating diagnostic LEDs on the system board

There are several diagnostic LEDs on the system board to help you diagnose specific problems. Figure 8 “Diagnostic LEDs on the system board” on page 16 shows the locations of the diagnostic LEDs on the system board.

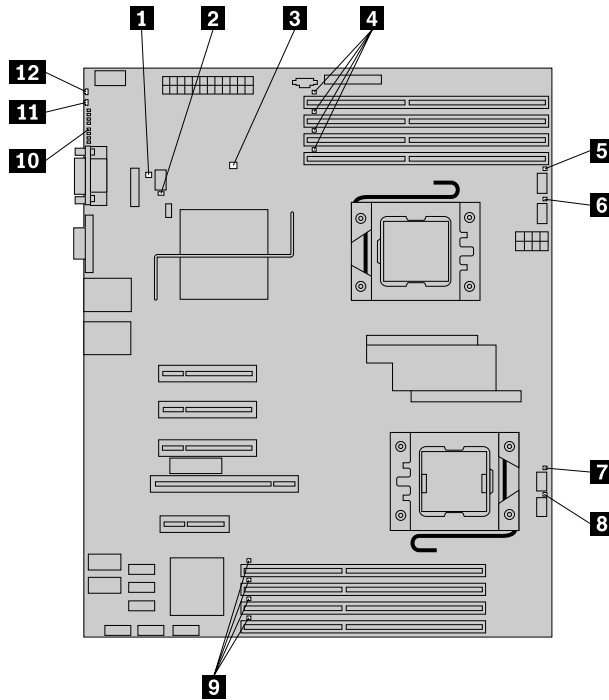

Figure 8. Diagnostic LEDs on the system board

- 1** Hard disk drive LED
- 2** System fan 3 fault LED
- 3** 5 VSB LED
- 4** DIMM fault LEDs (4)
- 5** System fan 2 fault LED
- 6** Microprocessor 1 heat sink fan fault LED
- 7** Microprocessor 2 heat sink fan fault LED
- 8** System fan 1 fault LED
- 9** DIMM fault LEDs (4)
- 10** Post-code diagnostic LEDs
- 11** Status LED
- 12** System ID LED

Jumper block settings

There are several jumper blocks on the system board that can be used to configure, recover, or enable/disable specific features of the server system board. Figure 9 “Jumper blocks on the system board” on page 17 shows the status of the jumper blocks on the system board.

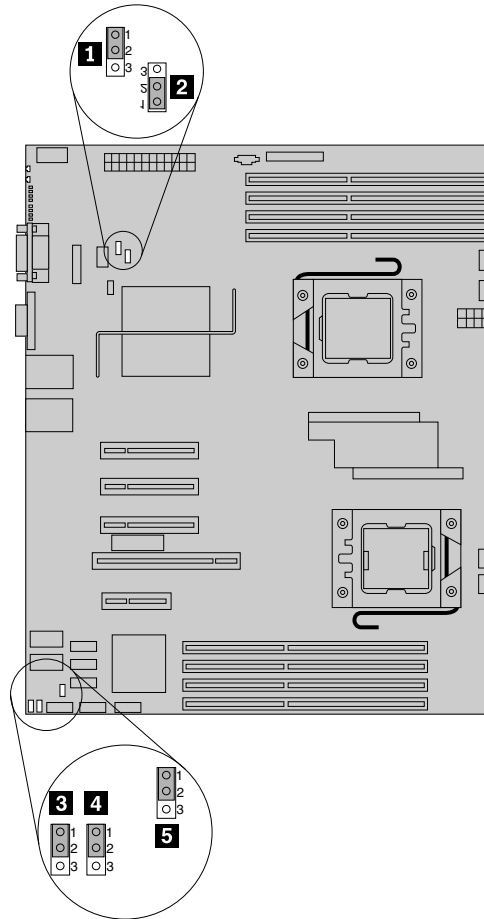

Figure 9. Jumper blocks on the system board

Table 7. Jumper block settings

Jumper block	Pin position	Description
1 J8B5: ME Force Update	Pins 1-2	These pins should have a jumper in place for normal system operation (default).
	Pins 2-3	ME force update model.
2 J8C1: BMC force update	Pins 1-2	BMC Firmware Force Update Mode – Disabled (default)
	Pins 2-3	BMC Firmware Force Update Mode – Enabled
3 J1A1: BIOS recovery	Pins 1-2	These pins should have a jumper in place for normal system operation (default).
	Pins 2-3	The main system BIOS will not boot with these pins jumpered. The system will boot from a bootable recovery media with a recovery BIOS image.

Table 7. Jumper block settings (continued)

Jumper block	Pin position	Description
4 J2D2: CMOS clear	Pins 1-2	These pins should have a jumper in place for normal system operation (default).
	Pins 2-3	If these pins are jumpered, the CMOS settings will be cleared on the next reset. These pins should not be jumpered for normal operation.
5 J2D1: Password clear	Pins 1-2	These pins should have a jumper in place for normal system operation (default).
	Pins 2-3	If these pins are jumpered, administrator and user passwords will be cleared on the next reset. These pins should not be jumpered for normal operation.

Note: Before clearing the CMOS, turn off the server and disconnect the power cord. Move the jumper from pins 1-2 to pins 2-3. Wait more than five minutes; then, move the jumper back to the normal position (pins 1-2 is short circuited) to clear CMOS.

Locating connectors on the hot-swap hard disk drive backplanes

There are two hot-swap hard disk drive backplanes installed in the server model with hot-swap hard disk drives. Figure 10 “Connector locations on the hot-swap hard disk drive backplanes” on page 19 shows the connector locations on the hot-swap hard disk drive backplanes.

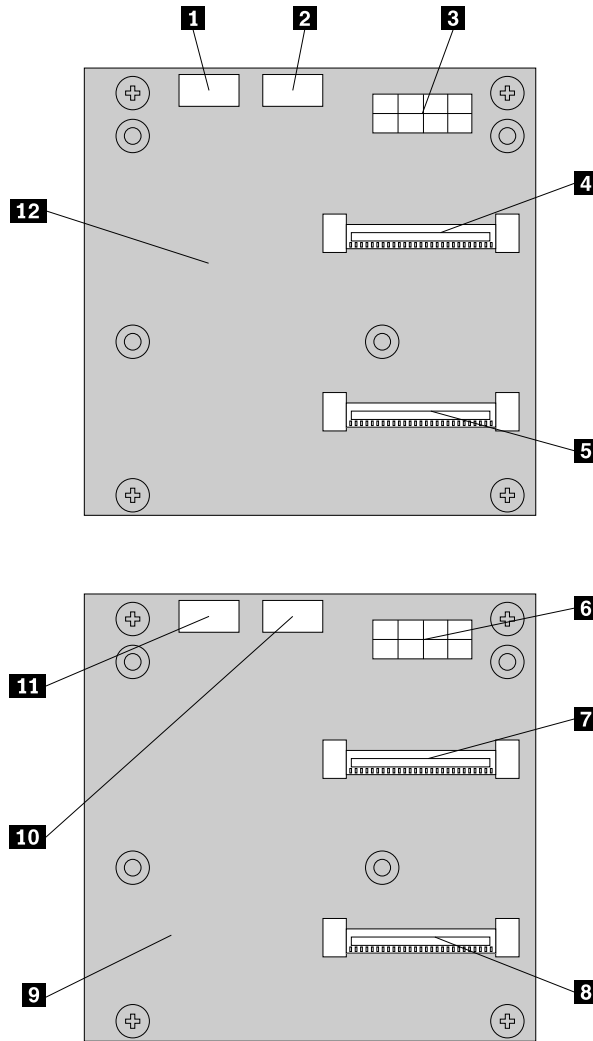

Figure 10. Connector locations on the hot-swap hard disk drive backplanes

- | | |
|---|---|
| 1 SATA/SAS signal connector 2 | 7 Hot-swap hard disk drive 1 connector |
| 2 SATA/SAS signal connector 3 | 8 Hot-swap hard disk drive 0 connector |
| 3 Power connector | 9 First hot-swap hard disk drive backplane |
| 4 Hot-swap hard disk drive 3 connector | 10 SATA/SAS signal connector 1 |
| 5 Hot-swap hard disk drive 2 connector | 11 SATA/SAS signal connector 0 |
| 6 Power connector | 12 Second hot-swap hard disk drive backplane |

Chapter 5. Installing, removing, or replacing hardware

This chapter provides instructions on how to install, remove, or replace hardware for your server.

This chapter contains the following topics:

- “Guidelines” on page 21
- “Removing the server cover” on page 23
- “Removing and reinstalling the front bezel” on page 25
- “Installing, removing, or replacing optional hardware devices” on page 29
- “Installing, removing, or replacing hardware devices” on page 69
- “Completing the parts replacement” on page 90

Guidelines

This section provides some guidelines that you should read and understand before using your server.

Basic guidelines

Before you use the server, be sure to read and understand the following guidelines:

- Be sure to read and understand the *Safety Information* and the *Warranty and Support Information* on the *ThinkServer Documentation DVD* that comes with your product, and “Guidelines” on page 21. These information will help you work safely. To obtain a copy of the publications, go to: <http://www.lenovo.com/support>
- When you install your new server, take the opportunity to download and apply the most recent firmware updates. This step will help to ensure that any known issues are addressed and that your server is ready to function at maximum levels of performance. To download firmware updates for your server, do the following:
 1. Go to <http://www.lenovo.com/support>.
 2. Click **Download & Drivers** → **ThinkServer** and then follow the instructions on the Web page to download firmware updates for your server.
- Before you install optional hardware devices, make sure that the server is working correctly. If an operating system is installed, turn on the server and make sure that the operating system starts. If no operating system is installed, make sure that a "19990305" error code is displayed, indicating that an operating system was not found but the server is working correctly. If the server is not working correctly, refer to the chapter Chapter 7 “Troubleshooting” on page 111 for detailed diagnostic information.
- Observe good housekeeping in the area where you are working. Put removed covers and other parts in a safe place.
- If you must turn on the server while the server cover is removed, make sure that no one is near the server and that no tools or other objects have been left inside the server.
- Do not attempt to lift an object that you think is too heavy for you. If you have to lift a heavy object, observe the following precautions:
 - Make sure that you can stand safely without slipping.
 - Distribute the weight of the object equally between your feet.
 - Use a slow lifting force. Never move suddenly or twist when you lift a heavy object.
 - To avoid straining the muscles in your back, lift by standing or by pushing up with your leg muscles.

- Make sure that you have an adequate number of properly grounded electrical outlets for the server, monitor, and other devices.
- Back up all important data before you make changes to drives.
- Have a small flat-blade screwdriver available.
- To view the error LEDs on the system board and internal components, leave the server connected to power.
- You do not have to turn off the server to install or replace hot-swap fans, redundant hot-swap ac power supplies, or hot-plug USB devices. However, you must turn off the server before performing any steps that involve installing, removing, or replacing adapter cables or non-hot-swap optional devices or components.
- After completing any installation, removal, or replacement procedure, reinstall all safety shields, guards, labels, and ground wires.
- For a list of supported optional devices for the server, go to <http://www.lenovo.com/thinkserver>.
- When working inside the server, you might find some tasks easier if you lay the server on its side. You might need to first pivot the foot stands inward and then lay the computer on its side.

System reliability guidelines

To help ensure proper cooling and system reliability, make sure that you follow these guidelines:

- Every drive bay has an internal drive installed or an Electro Magnetic Compatibility (EMC) shield installed.
- If the server has redundant power, every power supply bay has a power supply assembly installed.
- Leave adequate space around the server to make sure that the server cooling system works well.
- Properly route the cables. For some options, such as PCI cards, follow the cabling instructions that come with the options.
- Make sure that you replace a failed fan within 48 hours.
- When replacing a hot-swap drive, install the new hot-swap drive within two minutes of removal.
- Do not remove any air duct or air baffles while the server is running. Operating the server without the air duct or air baffles might cause the microprocessor to overheat.
- The second microprocessor socket always contains either a microprocessor socket cover or a microprocessor and heat sink.

Handling static-sensitive devices

Attention:

Do not open the static-protective package containing the new part until the defective part has been removed from the server and you are ready to install the new part. Static electricity, although harmless to you, can seriously damage server components and parts.

When you handle server parts and components, take these precautions to avoid static-electricity damage:

- Limit your movement. Movement can cause static electricity to build up around you.
- Wear an electrostatic-discharge wrist strap, if one is available.
- Always carefully handle the parts and other components (such as PCI cards, memory modules, system boards, and microprocessors) by its edges or its frame. Do not touch solder joints, pins, or exposed circuitry.
- Prevent others from touching the parts and other computer components.
- Before you replace a new part, touch the static-protective package containing the new part to a metal expansion-slot cover or other unpainted metal surface on the server for at least two seconds. This reduces static electricity from the package and your body.

- Remove the new part from the static-protective package and directly install it in the server without placing it on any other surface. If it is hard for you to do this in your specific situation, place the static-protective package of the new part on a smooth, level surface, and then place the new part on the static-protective package.
- Do not place the part on the server cover or other metal surface.
- Take additional care when handling devices during cold weather. Heating reduces indoor humidity and increases static electricity.

Working inside the server with the power on

Attention:

Static electricity that is released to internal server components when the server is turned on might cause the server to halt, which might result in the loss of data. To avoid this potential problem, always use an electrostatic-discharge wrist strap or other grounding system when you work inside the server with the power on.

The server supports hot-swap devices and is designed to operate safely while it is turned on and the cover is removed. Follow these guidelines when you work inside the server with the power on:

- Avoid wearing loose-fitting clothing on your forearms. Button long-sleeved shirts before working inside the server; do not wear cuff links while you are working inside the server.
- Do not allow your necktie or scarf to hang inside the server.
- Remove jewelry, such as bracelets, necklaces, rings, and loose-fitting wrist watches.
- Remove items from your shirt pocket, such as pens and pencils. These items might fall into the server as you lean over it.
- Avoid dropping any metallic objects into the server, such as paper clips, hairpins, and screws.

Removing the server cover

Attention:

Do not open your server or attempt any repair before reading and understanding the *Safety Information* and the *Warranty and Support Information* on the *ThinkServer Documentation DVD* that came with your product, and “Guidelines” on page 21. To obtain a copy of the publications, go to:
<http://www.lenovo.com/support>

This section provides instructions on how to remove the server cover.

Attention: For proper cooling and airflow, install the server cover before turning on the server. Operating the server for more than 30 minutes with the server cover removed might damage server components.

To remove the server cover, do the following:

1. Remove all media from the drives. Then, turn off all attached devices and the server.
2. Disconnect all power cords from electrical outlets.
3. Disconnect the power cord, Input/Output (I/O) cables, and all other cables that are connected to the server.
4. Remove any locking device that secures the server cover, such as a padlock.

5. Loosen the two thumbscrews attached on the rear of the server cover and then slide the server cover to the rear.

Notes:

- a. The two thumbscrews are securely installed and you need to use a tool, for example a screw driver, to loosen the thumbscrews.
- b. The two thumbscrews are integrated parts of the server cover and they cannot be removed from the server cover.

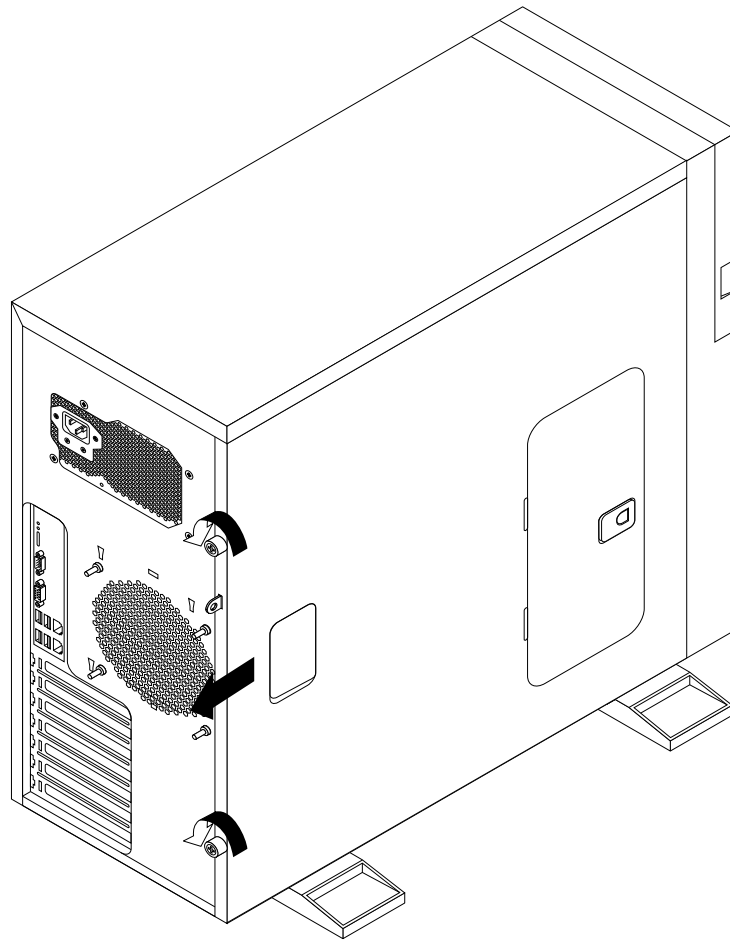

Figure 11. Sliding the server cover to the rear

6. Pivot the server cover outward to completely remove it.

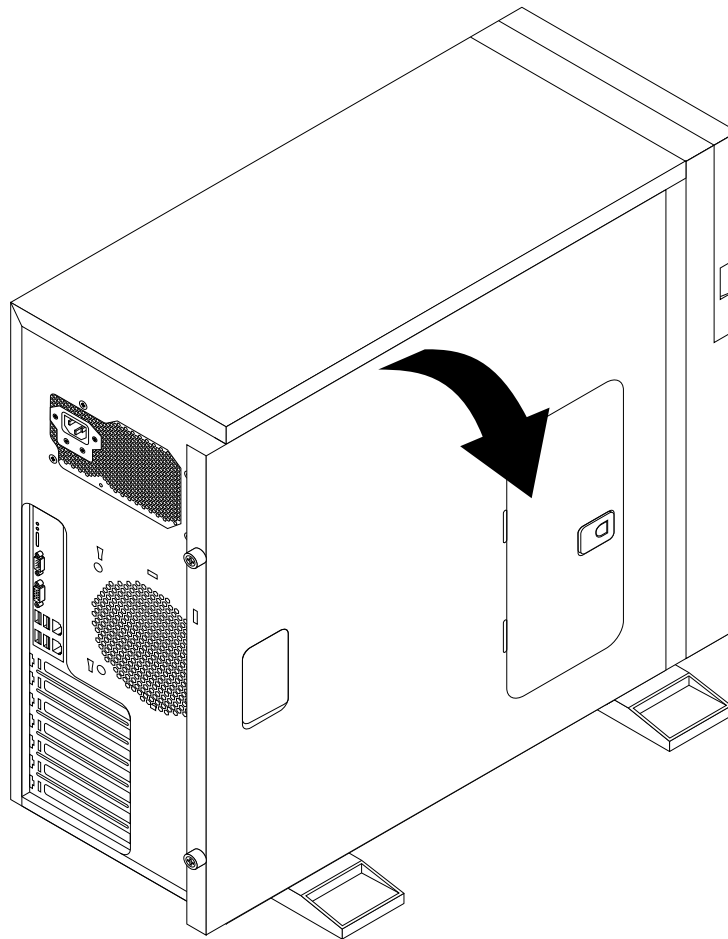

Figure 12. Removing the server cover

To reinstall the server cover, see “Installing the server cover” on page 91.

Removing and reinstalling the front bezel

Attention:

Do not open your server or attempt any repair before reading and understanding the *Safety Information* and the *Warranty and Support Information* on the *ThinkServer Documentation DVD* that came with your product, and “Guidelines” on page 21. To obtain a copy of the publications, go to:
<http://www.lenovo.com/support>

This section provides instructions on how to remove and reinstall the front bezel.

To remove and reinstall the front bezel, do the following:

1. Remove all media from the drives and turn off all attached devices and the server. Then, disconnect all power cords from electrical outlets and disconnect all cables that are connected to the server.
2. Remove the server cover. See “Removing the server cover” on page 23.

3. Remove the front bezel by releasing the three plastic tabs **1** on the left side and pulling the front bezel outward.

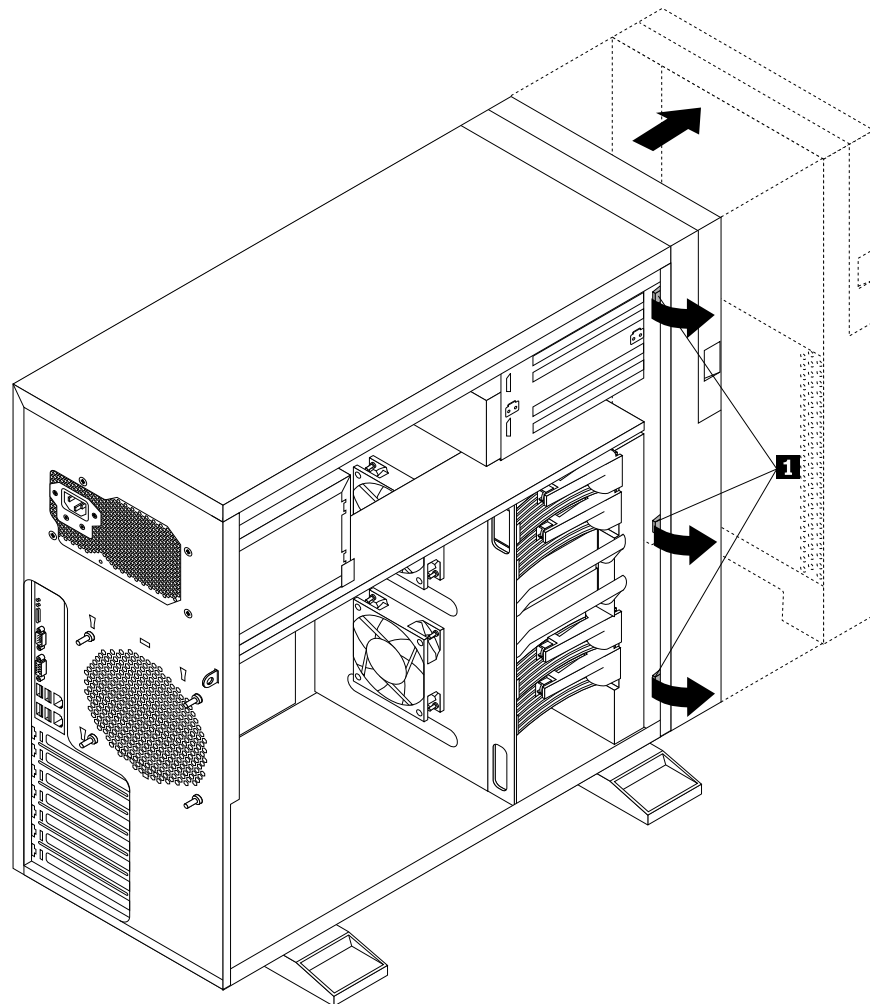

Figure 13. Removing the front bezel

4. To reinstall the front bezel, align the other three plastic tabs on the right side of the front bezel with the corresponding holes in the chassis, then pivot the front bezel inward until it snaps into position on the left side.
5. Go to “Completing the parts replacement” on page 90.

Locking or unlocking the hard disk drive side door

Attention:

Do not open your server or attempt any repair before reading and understanding the *Safety Information* and the *Warranty and Support Information* on the *ThinkServer Documentation DVD* that came with your product, and “Guidelines” on page 21. To obtain a copy of the publications, go to:
<http://www.lenovo.com/support>

This section provides instructions on how to lock or unlock the hard disk drive side door.

The hard disk drive side door of the server is unlocked when shipped from the factory. You can open the side door to view the hot-swap hard disk drive LED status, install a new hard disk drive, and remove or replace a failing hard disk drive. However, you can also lock the hard disk drive side door to ensure that all the hard disk drives cannot be accessed unless you remove the server cover. If you do so, you must turn off the server, disconnect all power cords, and remove the server cover when you want to replace any hard disk drives, including the hot-swap hard disk drives.

To lock or unlock the hard disk drive side door, do the following:

1. Press the blue button **1** to open the side door.

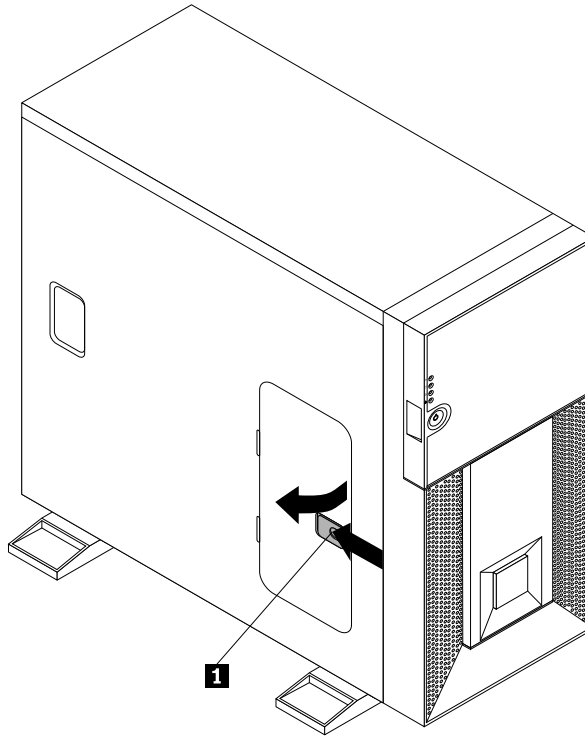

Figure 14. Opening the side door

2. Rotate the plastic latch of the side door to the closed position. Then, close the side door until it snaps into position. The side door is locked and cannot be opened when you press the blue button.

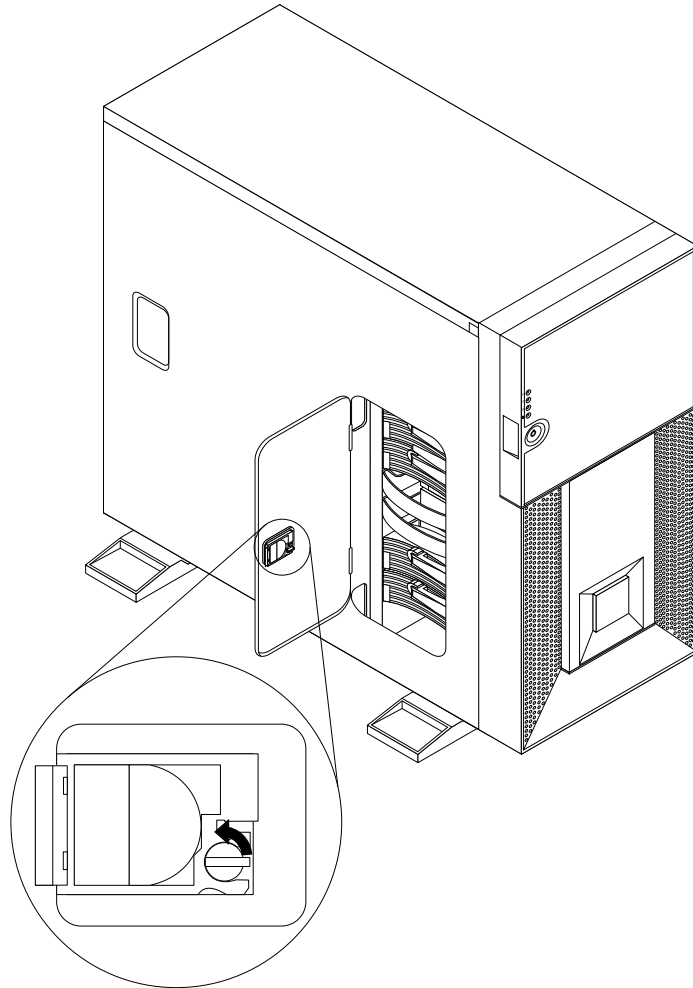

Figure 15. Locking the side door

3. To unlock the side door, remove the server cover. See “Removing the server cover” on page 23. Then, rotate the plastic latch of the side door to the open position. Reinstall the server cover. See “Installing the server cover” on page 91. The side door is unlocked and you can open the side door by pressing the blue button on it, as shown in Figure 14 “Opening the side door” on page 27.

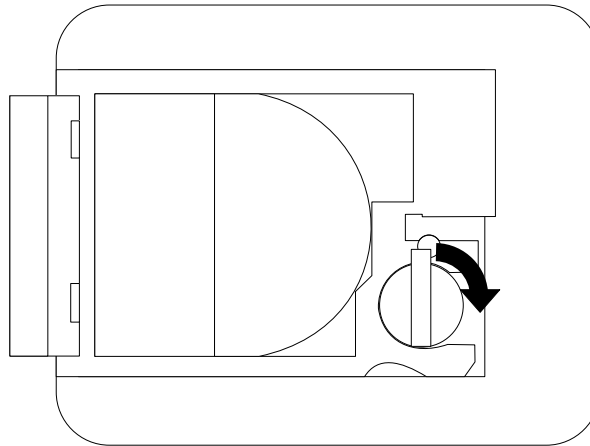

Figure 16. Unlocking the side door

Installing, removing, or replacing optional hardware devices

This section provides instructions on how to install, remove, or replace optional hardware devices for your server. You can expand the capabilities of your server by adding memory modules, PCI cards, or drives, and maintain your server by replacing the failing optional hardware devices. If you are replacing an optional hardware device, perform the removal procedure and then perform the installation procedure for the optional hardware device that you want to replace.

Installing or removing a memory module

This section provides instructions on how to install or remove a memory module. For a list of the supported memory modules for your server, go to <http://www.lenovo.com/thinkserver>. On the ThinkServer systems page, click **Products** → **Options** → **ThinkServer Memory**.

Memory module installation rules

Your server has eight memory slots for installing or replacing DDR3 SDRAM DIMMs that provide up to a maximum of 64 GB of system memory.

The following table provides information about the memory module installation rules that you should consider when installing a memory module. The “X” mark indicates the suggested memory slot(s) into which the memory module(s) should be installed in different situations. The number, for example 1, 2, or 3, indicates the installation sequence. See “Locating parts on the system board” on page 15 to identify the various memory slots.

Note: All memory module types and capacities must be consistent.

Table 8. Memory module installation rules

CPU	DIMM	CPU1 DIMM CHA2	CPU1 DIMM CHA1	CPU1 DIMM CHB2	CPU1 DIMM CHB1	CPU2 DIMM CHD2	CPU2 DIMM CHD1	CPU2 DIMM CHE2	CPU2 DIMM CHE1
CPU 1	One DIMM		X						
	Two DIMMs*		X, 1		X, 2				
	Four DIMMs	X, 3	X, 1	X, 4	X, 2				
CPU 1 and CPU 2	Two DIMMs		X, 1				X, 2		
	Four DIMMs*		X, 1		X, 3		X, 2		X, 4
	Six DIMMs	X, 5	X, 1		X, 3	X, 6	X, 2		X, 4
	Eight DIMMs	X, 5	X, 1	X, 7	X, 3	X, 6	X, 2	X, 8	X, 4

Note: * denotes the Channel Mirroring Mode. This mode requires that you install the DIMMs in pair.

Installing a memory module

Attention:

Do not open your server or attempt any repair before reading and understanding the *Safety Information* and the *Warranty and Support Information* on the *ThinkServer Documentation DVD* that came with your product, and “Guidelines” on page 21. To obtain a copy of the publications, go to:
<http://www.lenovo.com/support>

This section provides instructions on how to install a memory module.

To install a memory module, do the following:

1. Remove all media from the drives and turn off all attached devices and the server. Then, disconnect all power cords from electrical outlets and disconnect all cables that are connected to the server.
2. Remove the server cover. See “Removing the server cover” on page 23.
3. Locate the appropriate memory slot on the system board into which you will install the memory module. To optimize system performance, follow the related memory module installation rules and install the memory module into a memory slot starting with the memory module farthest from the microprocessor. See “Memory module installation rules” on page 29.

4. Open the retaining clips of the memory slot into which you want to install the memory module.

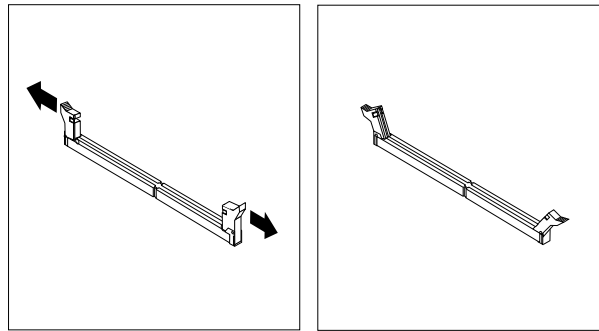

Figure 17. Opening the retaining clips of the memory slot

5. Touch the static-protective package that contains the new memory module to any unpainted metal surface on the outside of the server. Then, remove the new memory module from the package.
6. Position the new memory module over the memory slot. Make sure that the notch **1** on the new memory module is aligned with the key **2** in the memory slot. Then, press the new memory module straight down into the memory slot until the retaining clips close and the new memory module snaps into position.

Note: If there is a gap between the memory module and the retaining clips, the memory module has not been correctly installed. Open the retaining clips, remove the memory module, and then reinstall it into the slot.

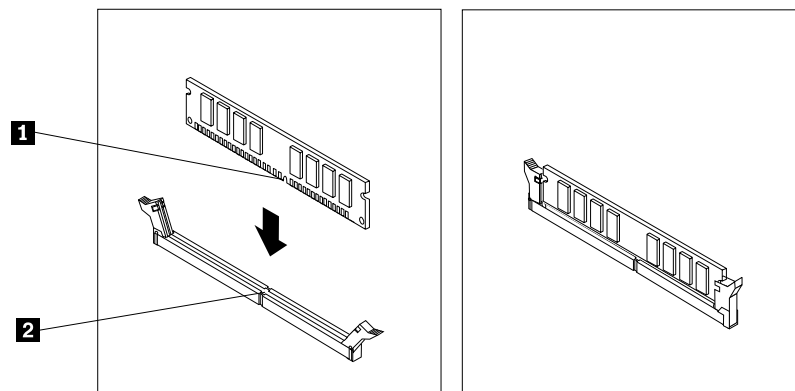

Figure 18. Installing the memory module

What to do next:

- To work with another piece of hardware, go to the appropriate section.
- To complete the installation or replacement, go to “Completing the parts replacement” on page 90.

Removing a memory module

Attention:

Do not open your server or attempt any repair before reading and understanding the *Safety Information* and the *Warranty and Support Information* on the *ThinkServer Documentation DVD* that came with your product, and “Guidelines” on page 21. To obtain a copy of the publications, go to:
<http://www.lenovo.com/support>

This section provides instructions on how to remove a memory module.

To remove a memory module, do the following:

1. Remove all media from the drives and turn off all attached devices and the server. Then, disconnect all power cords from electrical outlets and disconnect all cables that are connected to the server.
2. Remove the server cover. See “Removing the server cover” on page 23.
3. Locate the memory slot with the memory module that you want to remove. See “Locating parts on the system board” on page 15 for the locations of the memory slots.
4. Carefully open the retaining clips on each end of the memory slot and then grasp the memory module straight up by its edges.

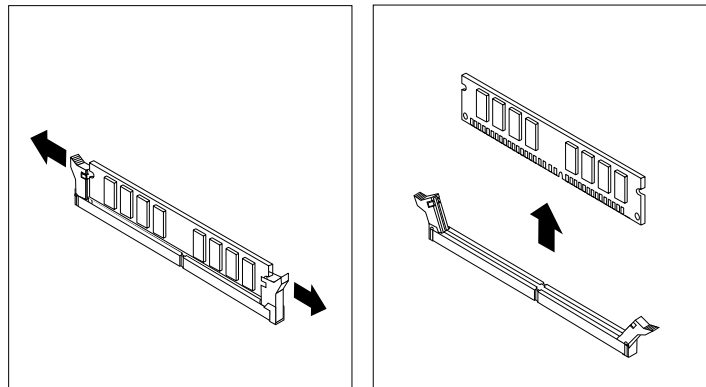

Figure 19. Removing the memory module

5. If you are instructed to return the failing memory module, follow all packaging instructions, and use any packaging materials for shipping that are supplied to you.

What to do next:

- To work with another piece of hardware, go to the appropriate section.
- To complete the removal procedure, go to “Completing the parts replacement” on page 90.

Removing or installing internal drives

This section provides instructions on how to remove or install internal drives for the server. See “Features and specifications” on page 5 for information about the types of internal drives that the server supports and see “Locating server components” on page 14 for the locations of the drive bays in the server.

When installing an internal drive, be sure to consider the following information:

- Make sure that you have all the cables and other equipment specified in the documentation that came with the drive.
- Note the type and size of the drive and select the appropriate drive bay to install the drive.
- Check the instructions that came with the drive to see whether you have to set any switches or jumpers on the drive. If you are installing a SAS device, be sure to set the SAS ID for that device.
- The EMI integrity and cooling of the server are protected by having all drive bays and PCI card slots covered or occupied. When you install a drive or a PCI card, save the EMC shield or filler panel from the drive bay or save the PCI card slot cover in the event that you later remove the device. An unoccupied drive bay or PCI card slot without cover, shield, filler, or any other protection might impact the EMI integrity and cooling of the server, which might result in overheating or component damage.

- For a list of the supported hard disk drives for your server, go to <http://www.lenovo.com/thinkserver>. On the ThinkServer systems page, click **Products** → **Options** → **ThinkServer Hard Drives**.

Removing the optical drive

Attention:

Do not open your server or attempt any repair before reading and understanding the *Safety Information* and the *Warranty and Support Information* on the *ThinkServer Documentation DVD* that came with your product, and “Guidelines” on page 21. To obtain a copy of the publications, go to:
<http://www.lenovo.com/support>

This section provides instructions on how to remove the optical drive.

To remove the optical drive, do the following:

1. Remove all media from the drives and turn off all attached devices and the server. Then, disconnect all power cords from electrical outlets and disconnect all cables that are connected to the server.
2. Remove the server cover. See “Removing the server cover” on page 23.
3. Remove the front bezel. See “Removing and reinstalling the front bezel” on page 25.
4. Disconnect the signal cable and the power cable from the rear of the optical drive.

5. Press the optical drive retainers **1** on both sides of the optical drive and slide the optical drive out of the front of the server.

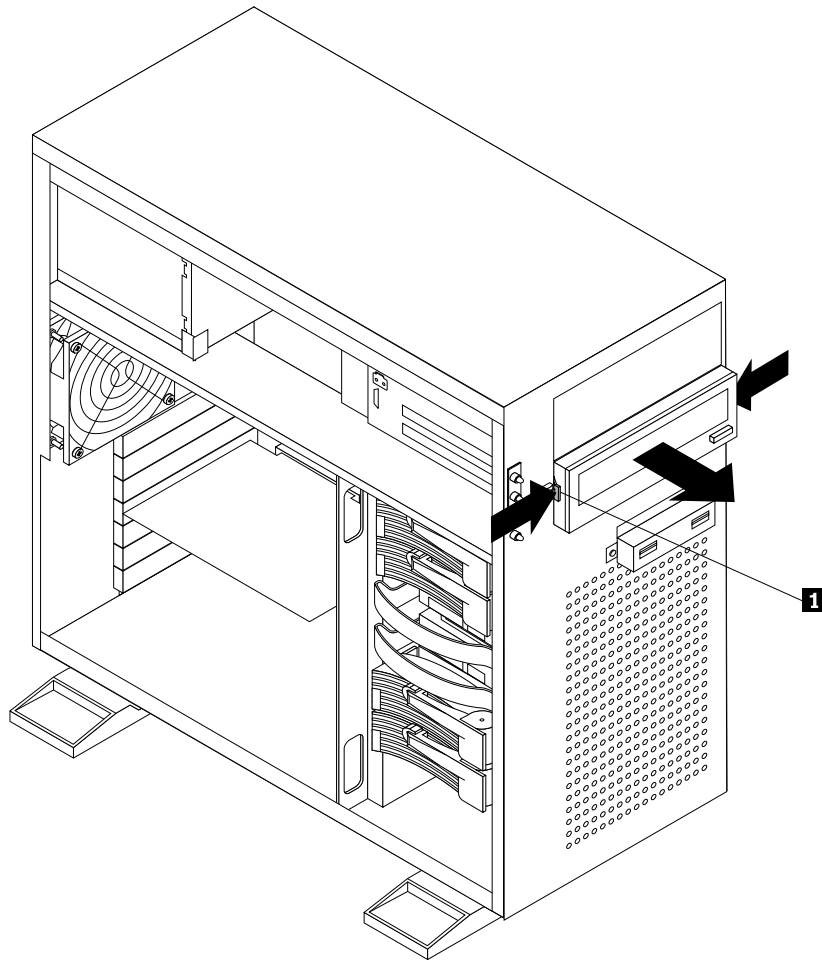

Figure 20. Removing the optical drive

6. Remove the optical drive retainers from both sides of the old optical drive and save them to use when you install a new optical drive.

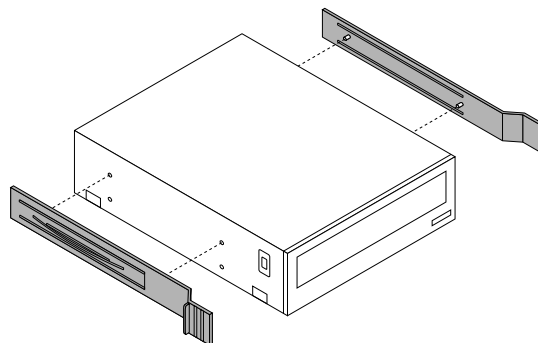

Figure 21. Removing the optical drive retainers

7. If you are instructed to return the removed optical drive to the manufacturer, follow all packaging instructions and use any packaging materials that are supplied to you for shipping.

What to do next:

- To work with another piece of hardware, go to the appropriate section.
- To complete the removal procedure, go to “Completing the parts replacement” on page 90.

Installing the optical drive

Attention:

Do not open your server or attempt any repair before reading and understanding the *Safety Information* and the *Warranty and Support Information* on the *ThinkServer Documentation DVD* that came with your product, and “Guidelines” on page 21. To obtain a copy of the publications, go to:
<http://www.lenovo.com/support>

This section provides instructions on how to install the optical drive.

To install the optical drive, do the following:

1. If you are replacing the optical drive, make sure that:
 - You have all the cables and other equipment that is specified in the documentation that comes with the new optical drive.
 - You have checked the instructions that come with the new optical drive to determine whether you must set any switches or jumpers in the optical drive.
 - You have removed the optical drive retainers from both sides of the old optical drive and have them available for installation on the new optical drive.

Note: If you are installing a laser device (such as a drive), observe the following safety precautions.

Statement 3



CAUTION:

When laser products (such as CD-ROMs, DVD drives, fiber optic devices, or transmitters) are installed, note the following:

- **Do not remove the covers. Removing the covers of the laser product could result in exposure to hazardous laser radiation. There are no serviceable parts inside the device.**
- **Use of controls or adjustments or performance of procedures other than those specified herein might result in hazardous radiation exposure.**



DANGER

Some laser products contain an embedded Class 3A or Class 3B laser diode. Note the following.

Laser radiation when open. Do not stare into the beam, do not view directly with optical instruments, and avoid direct exposure to the beam.

2. Remove all media from the drives and turn off all attached devices and the server. Then, disconnect all power cords from electrical outlets and disconnect all cables that are connected to the server.
3. Remove the server cover. See “Removing the server cover” on page 23.
4. Remove the front bezel. See “Removing and reinstalling the front bezel” on page 25.

5. Touch the static-protective package that contains the new optical drive to any unpainted metal surface on the server. Then, remove the new optical drive from the package and place it on a static-protective surface.
6. Install the optical drive retainers on both sides of the new optical drive.

Note: Note the orientation of the optical drive retainers and the corresponding holes in both sides of the optical drive when installing the retainers.

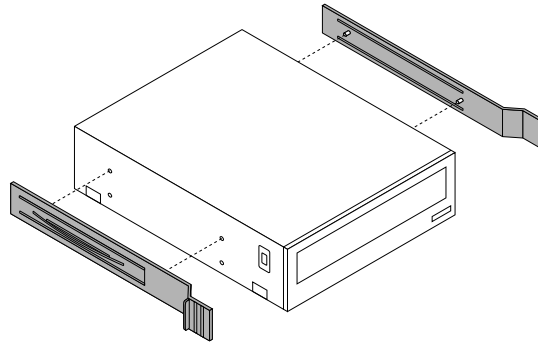

Figure 22. Installing the optical drive retainers

- Slide the new optical drive into the drive bay until it snaps into position.

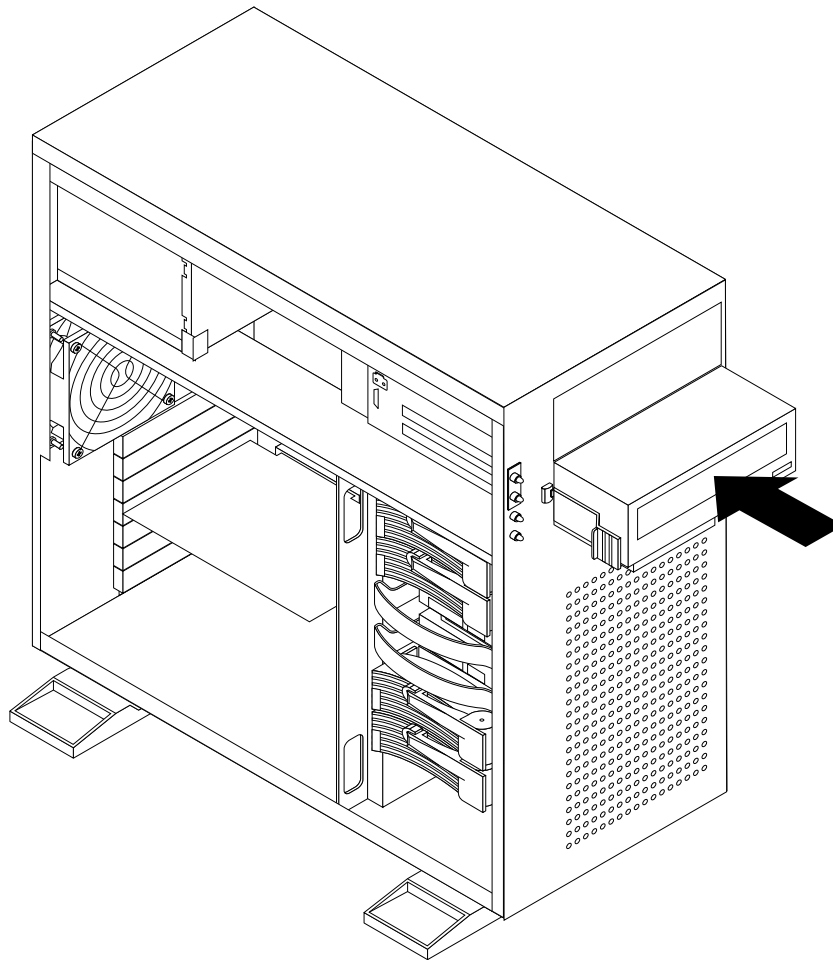

Figure 23. Installing the optical drive

- Connect one end of the signal cable **2** to the rear of the new optical drive and the other end to an available SATA connector (SATA connector 5 recommended) on the system board. See “Locating parts on the system board” on page 15. Then, locate an available five-wire power connector **1** and connect it to the rear of the new optical drive.

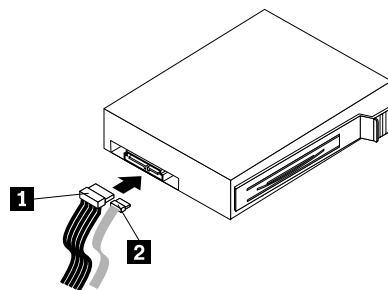

Figure 24. Connecting the optical drive cables

What to do next:

- To work with another piece of hardware, go to the appropriate section.
- To complete the installation, go to “Completing the parts replacement” on page 90.

Removing a hot-swap hard disk drive

Attention:

Do not open your server or attempt any repair before reading and understanding the *Safety Information* and the *Warranty and Support Information* on the *ThinkServer Documentation DVD* that came with your product, and “Guidelines” on page 21. To obtain a copy of the publications, go to:
<http://www.lenovo.com/support>

This section provides instructions on how to remove a hot-swap hard disk drive. This section applies only to server models that have hot-swap hard disk drives installed.

Attention: To maintain proper system cooling, do not operate the server for more than 10 minutes without either a drive or a filler panel installed in each drive bay.

To remove a hot-swap hard disk drive, do the following:

Note: You do not have to turn off the server when removing a hot-swap hard disk drive. However, if you have locked the side door, you must turn off the server, disconnect all power cords, and remove the server cover when you want to remove, install, or replace any hard disk drives. See “Locking or unlocking the hard disk drive side door” on page 26 and “Removing the server cover” on page 23.

1. Press the blue button **1** to open the side door.

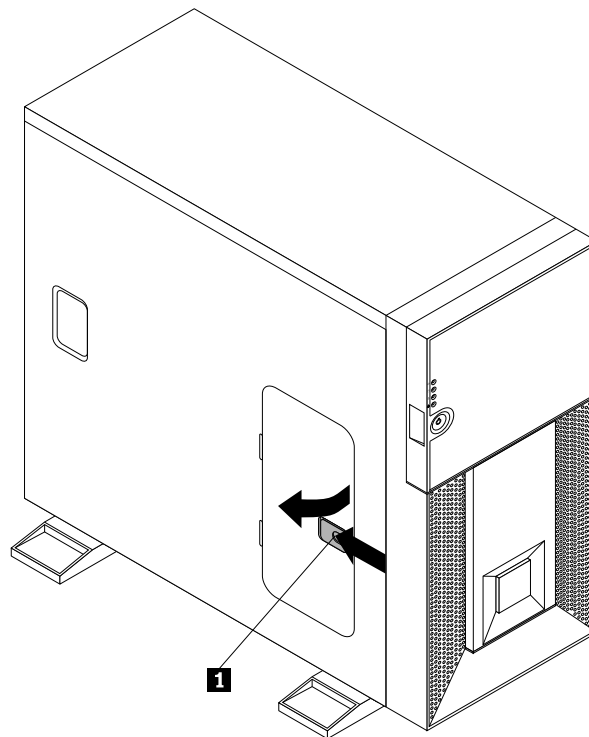

Figure 25. Opening the side door

2. Locate the hot-swap hard disk drive you want to remove. Then, press the blue release button **1** and rotate the handle of the hard disk drive bracket to the open position.

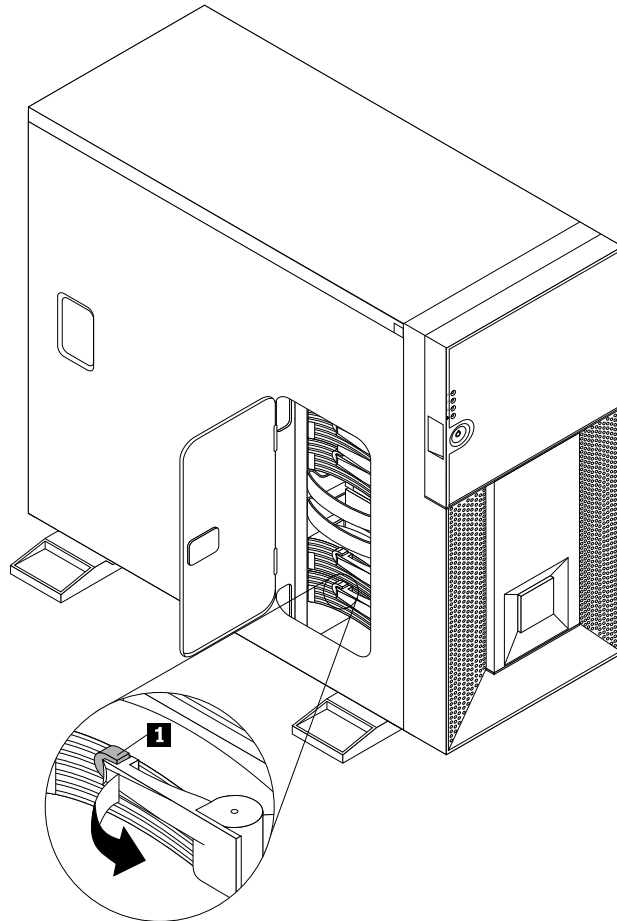

Figure 26. Opening the handle of the hot-swap hard disk drive bracket

3. Grasp the handle **1** and pull the hard disk drive bracket with the hard disk drive out of the drive bay.

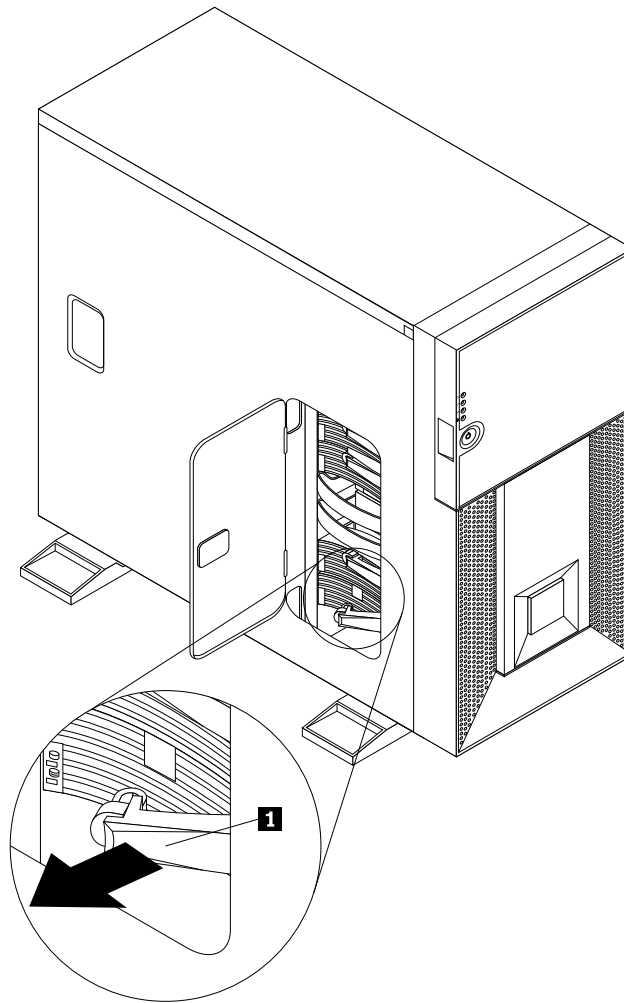

Figure 27. Removing the hot-swap hard disk drive bracket with the hard disk drive

4. Remove the four screws that secure the hard disk drive and then remove the hard disk drive from the bracket.

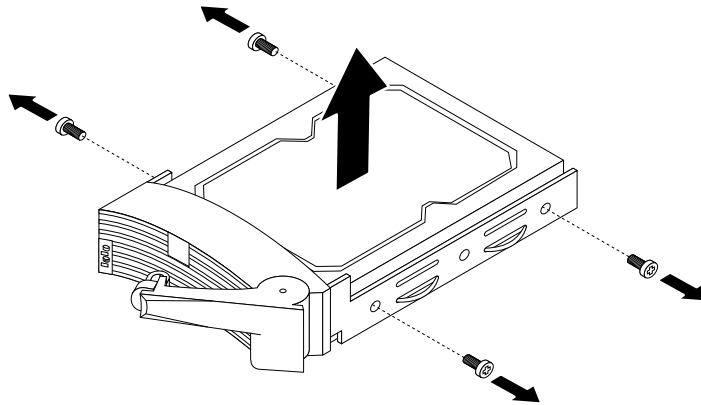

Figure 28. Removing the hot-swap hard disk drive

5. If you are instructed to return the removed hot-swap hard disk drive to the manufacturer, follow all packaging instructions and use any packaging materials that are supplied to you for shipping.

What to do next:

- To work with another piece of hardware, go to the appropriate section.
- To complete the removal procedure, go to “Completing the parts replacement” on page 90.

Installing a hot-swap hard disk drive

Attention:
Do not open your server or attempt any repair before reading and understanding the *Safety Information* and the *Warranty and Support Information* on the *ThinkServer Documentation DVD* that came with your product, and “Guidelines” on page 21. To obtain a copy of the publications, go to:
<http://www.lenovo.com/support>

This section provides instructions on how to install a hot-swap hard disk drive. This section applies only to server models that support hot-swap hard disk drives.

Attention: To maintain proper system cooling, do not operate the server for more than 10 minutes without either a drive or a filler panel installed in each drive bay.

To install a hot-swap hard disk drive, do the following:

Notes:

1. You do not have to turn off the server for the installation of a hot-swap hard disk drive. However, if you have locked the side door, you must turn off the server, disconnect all power cords, and remove the server cover when you want to remove, install, or replace any hard disk drives. See “Locking or unlocking the hard disk drive side door” on page 26 and “Removing the server cover” on page 23.
2. The cables come with the hard disk drive option kit will not be used if you are installing a hot-swap hard disk drive.

1. Press the blue button **1** to open the side door.

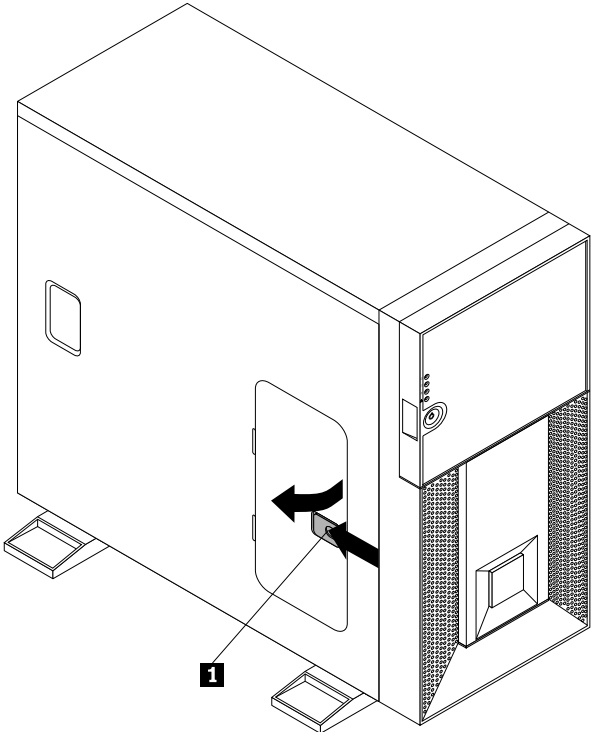

Figure 29. Opening the side door

2. Locate a hot-swap hard disk drive bay that you want to install the drive. Then, press the blue release button **1** and rotate the handle of the hard disk drive bracket to the open position.

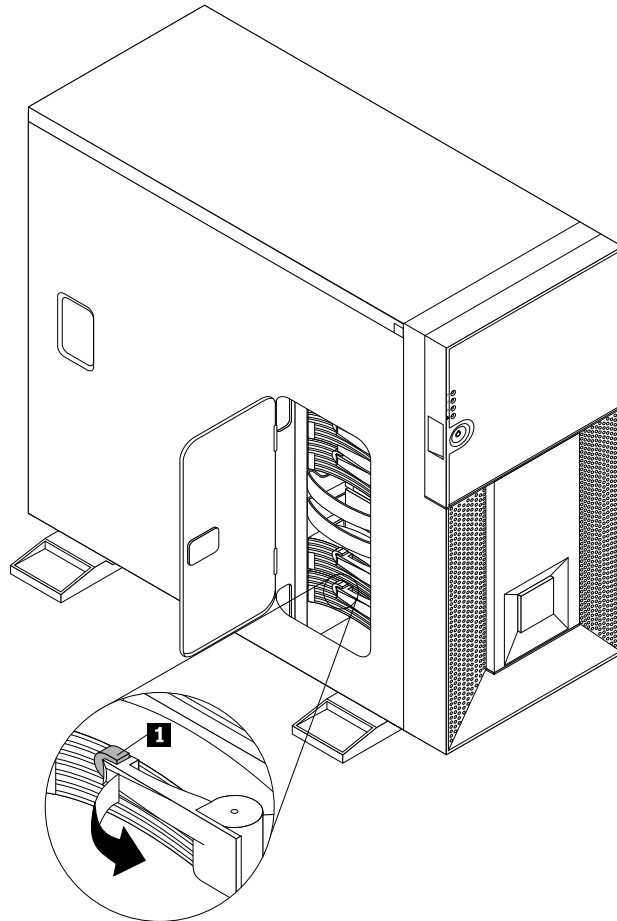

Figure 30. Opening the handle of the hot-swap hard disk drive bracket

3. Grasp the handle **1** and pull the hard disk drive bracket out of the drive bay.

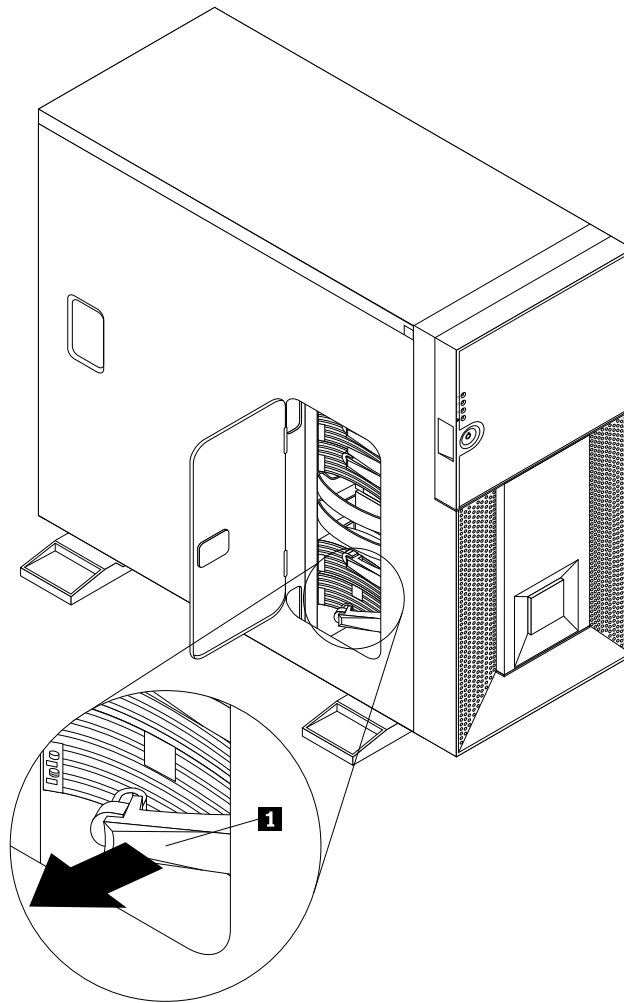

Figure 31. Removing the hot-swap hard disk drive bracket

4. Remove the plastic drive bay filler and save it for future use.

Note: The EMI integrity and cooling of the server are protected by having all drive bays and PCI card slots covered or occupied. When you install a drive or PCI card, save the EMC shield or drive bay filler from the drive bay or save the PCI card slot cover in the event that you later remove the device. An unoccupied drive bay or PCI card slot without cover, shield, filler, or any other protection might impact the EMI integrity and cooling of the server, which might result in overheating or component damage.

5. Touch the static-protective package that contains the new hard disk drive to any unpainted metal surface on the server. Then, remove the hard disk drive from the package.

6. Align the screw holes in both sides of the hard disk drive with the corresponding holes in the hard disk drive bracket. Then, install the four screws to secure the hard disk drive in the bracket.

Note: Carefully install the hard disk drive without touching the circuit board on the bottom of the hard disk drive.

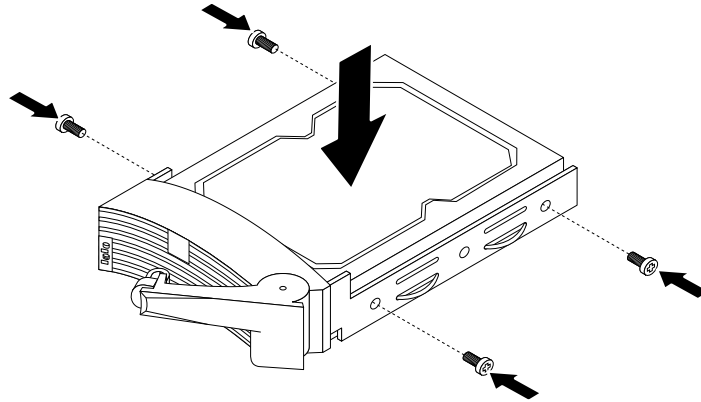

Figure 32. Installing the hard disk drive into the bracket

7. Keep the handle of the hot-swap hard disk drive bracket fully open and then slide the bracket with the hard disk drive into the drive bay until it cannot be pushed in anymore.

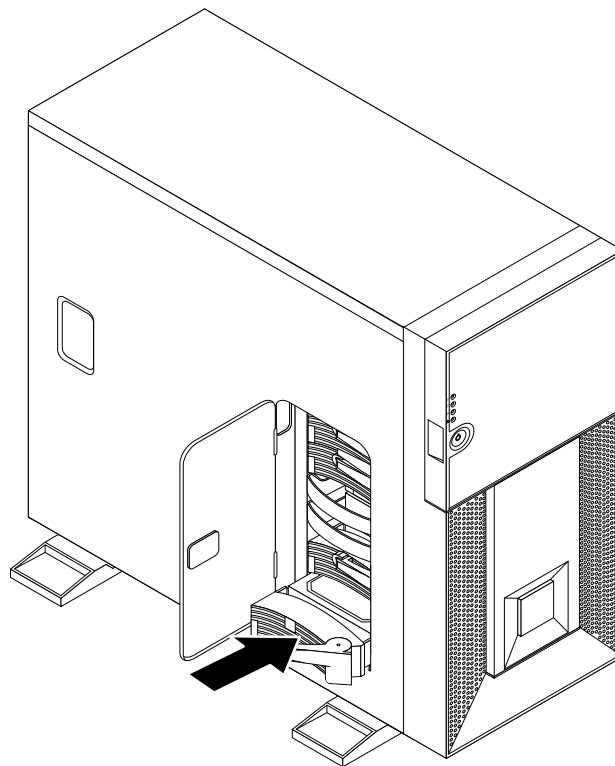

Figure 33. Sliding the hot-swap hard disk drive bracket with the hard disk drive into the bay

8. Press the handle **1** to rotate it to the closed position until the blue release button snaps into place and the bracket with the hard disk drive is securely locked in the drive bay.

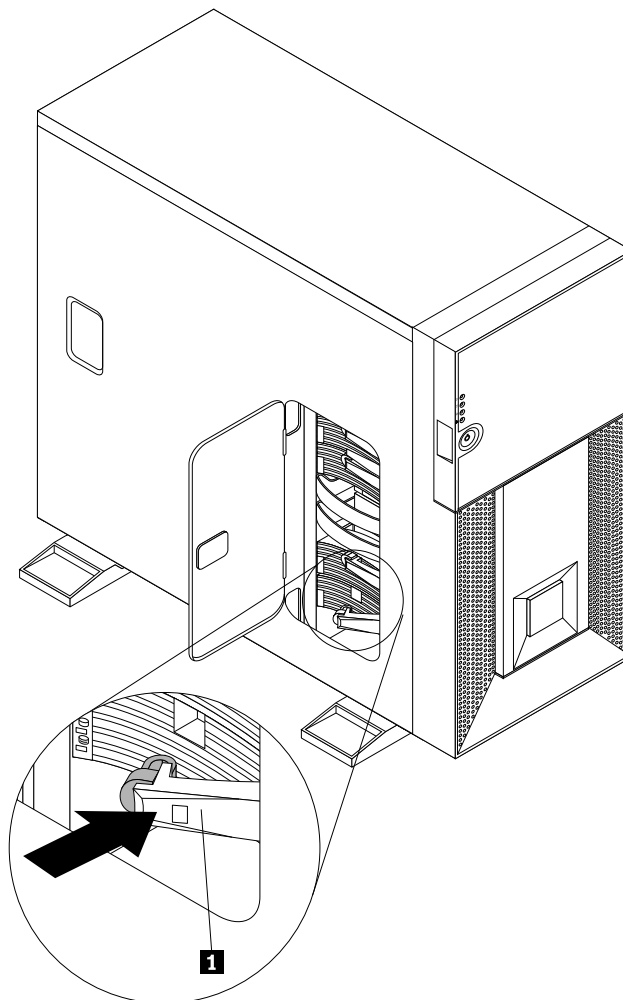

Figure 34. Locking the hot-swap hard disk drive in the drive bay

9. Check the hard disk drive status LEDs to make sure that the hard disk drive is operating correctly. You might have to restart the server for the newly installed drive to be recognized. If the amber hard disk drive status LED is lit continuously, this indicates that the hard disk drive is faulty and must be replaced; if the green hard disk drive status LED is blinking, this indicates that the hard disk drive is operating correctly.

Note: If the server is configured for RAID operation using a RAID controller, you might have to reconfigure the disk arrays after you replace hard disk drives.

What to do next:

- To work with another piece of hardware, go to the appropriate section.
- To complete the installation, go to “Completing the parts replacement” on page 90.

Removing a non-hot-swap hard disk drive

Attention:

Do not open your server or attempt any repair before reading and understanding the *Safety Information* and the *Warranty and Support Information* on the *ThinkServer Documentation DVD* that came with your product, and “Guidelines” on page 21. To obtain a copy of the publications, go to:
<http://www.lenovo.com/support>

This section provides instructions on how to remove a non-hot-swap hard disk drive. This section applies only to server models that have non-hot-swap hard disk drives installed.

Attention: To maintain proper system cooling, do not operate the server for more than 10 minutes without either a drive or a filler panel installed in each drive bay.

To remove a non-hot-swap hard disk drive, do the following:

1. Remove all media from the drives and turn off all attached devices and the server. Then, disconnect all power cords from electrical outlets and disconnect all cables that are connected to the server.
2. Press the blue button **1** to open the side door.

Note: If you have locked the side door, you must turn off the server, disconnect all power cords, and remove the server cover when you want to remove, install, or replace any hard disk drives. See “Locking or unlocking the hard disk drive side door” on page 26 and “Removing the server cover” on page 23.

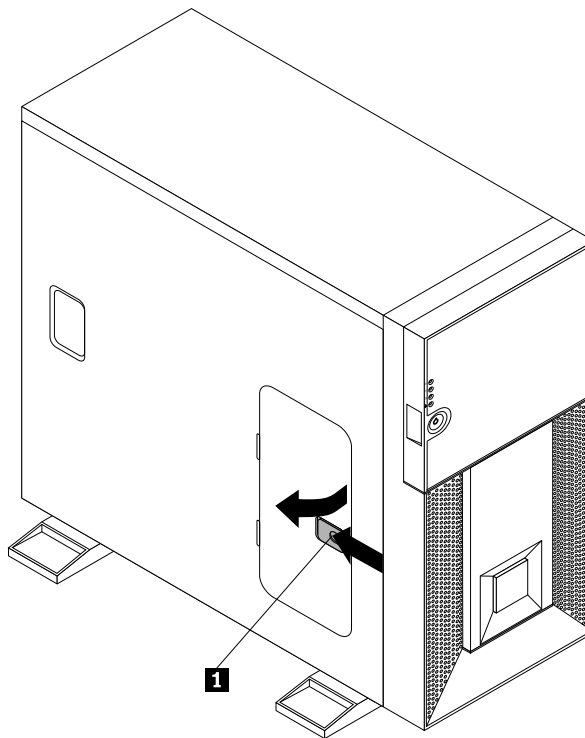

Figure 35. Opening the side door

3. Locate the non-hot-swap hard disk drive you want to remove and disconnect the power cable and the signal cable from the hard disk drive. Then, pull the handle of the hard disk drive bracket to slide the bracket with the hard disk drive out of the drive bay.

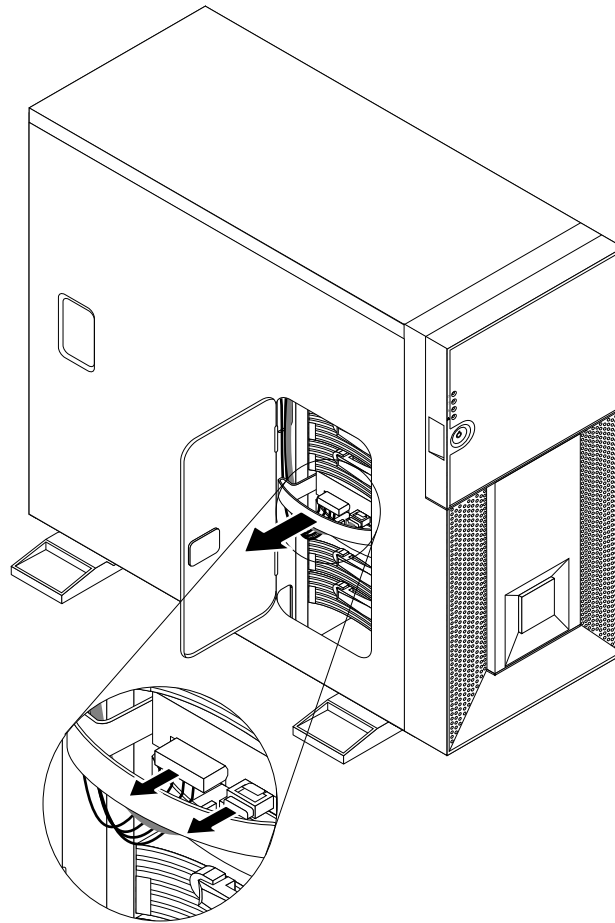

Figure 36. Disconnecting cables and sliding the non-hot-swap hard disk drive out

4. Depending on the non-hot-swap hard disk drive is secured in the bracket by screws or plastic retainers, do one of the following:

- If the non-hot-swap hard disk drive is secured in the bracket by screws, remove the four screws and then remove the hard disk drive from the bracket.

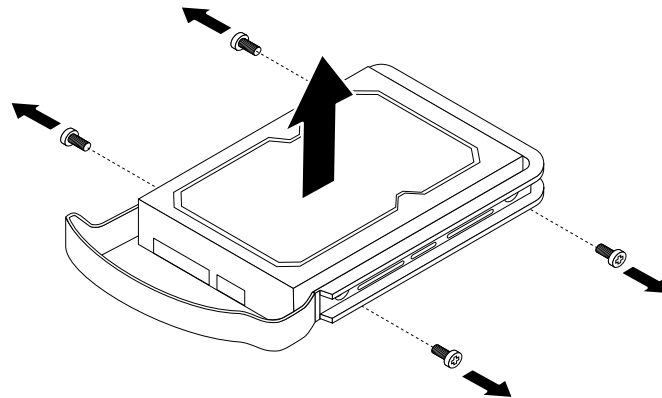

Figure 37. Removing the screws that secure the hard disk drive

- If the non-hot-swap hard disk drive is secured in the bracket by retainers, remove the retainers on both sides and then remove the hard disk drive from the bracket.

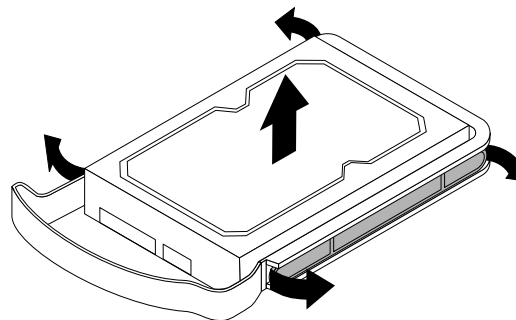

Figure 38. Removing the retainers that secure the hard disk drive

5. If you are instructed to return the removed non-hot-swap hard disk drive to the manufacturer, follow all packaging instructions and use any packaging materials that are supplied to you for shipping.

What to do next:

- To work with another piece of hardware, go to the appropriate section.
- To complete the removal procedure, go to “Completing the parts replacement” on page 90.

Installing a non-hot-swap hard disk drive

Attention:
 Do not open your server or attempt any repair before reading and understanding the *Safety Information* and the *Warranty and Support Information* on the *ThinkServer Documentation DVD* that came with your product, and “Guidelines” on page 21. To obtain a copy of the publications, go to:
<http://www.lenovo.com/support>

This section provides instructions on how to install a non-hot-swap hard disk drive. This section applies only to server models that support non-hot-swap hard disk drives.

Attention: To maintain proper system cooling, do not operate the server for more than 10 minutes without either a drive or a filler panel installed in each drive bay.

To install a non-hot-swap hard disk drive, do the following:

1. Remove all media from the drives and turn off all attached devices and the server. Then, disconnect all power cords from electrical outlets and disconnect all cables that are connected to the server.
2. Press the blue button **1** to open the side door.

Note: If you have locked the side door, you must turn off the server, disconnect all power cords, and remove the server cover when you want to remove, install, or replace any hard disk drives. See “Locking or unlocking the hard disk drive side door” on page 26 and “Removing the server cover” on page 23.

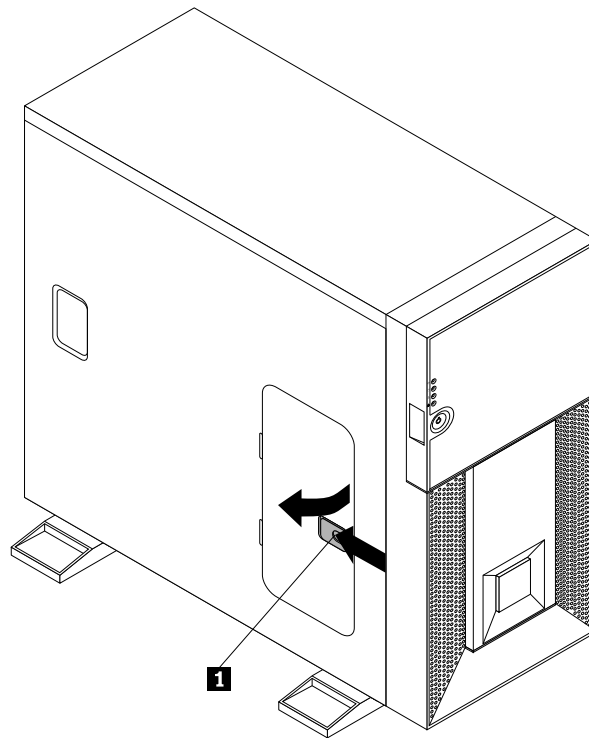

Figure 39. Opening the side door

3. Locate a non-hot-swap hard disk drive bay that you want to install the drive. Then, pull the handle of the hard disk drive bracket to slide the bracket out of the drive bay.

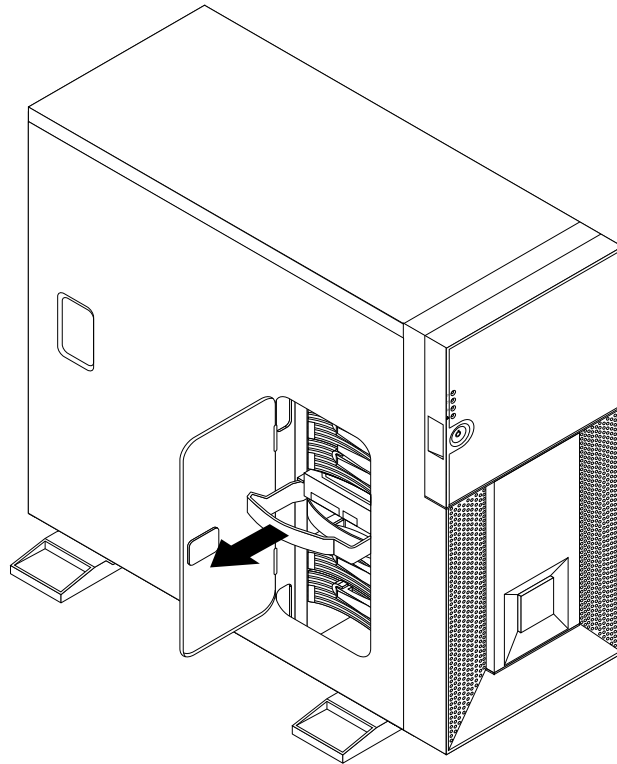

Figure 40. Sliding the non-hot-swap hard disk drive bracket out

4. Remove the plastic drive bay filler and save it for future use.

Note: The EMI integrity and cooling of the server are protected by having all drive bays and PCI card slots covered or occupied. When you install a drive or PCI card, save the EMC shield or drive bay filler from the drive bay or save the PCI card slot cover in the event that you later remove the device. An unoccupied drive bay or PCI card slot without cover, shield, filler, or any other protection might impact the EMI integrity and cooling of the server, which might result in overheating or component damage.

5. Touch the static-protective package that contains the new hard disk drive to any unpainted metal surface on the server. Then, remove the hard disk drive from the package.
6. Depending on you will secure the hard disk drive in the bracket by screws or plastic retainers, do one of the following:

Note: Carefully install the hard disk drive without touching the circuit board on the bottom of the hard disk drive.

- If you want to secure the hard disk drive in the bracket by screws, align the screw holes in both sides of the hard disk drive with the corresponding holes in the bracket. Then, install the four screws to secure the hard disk drive in the bracket.

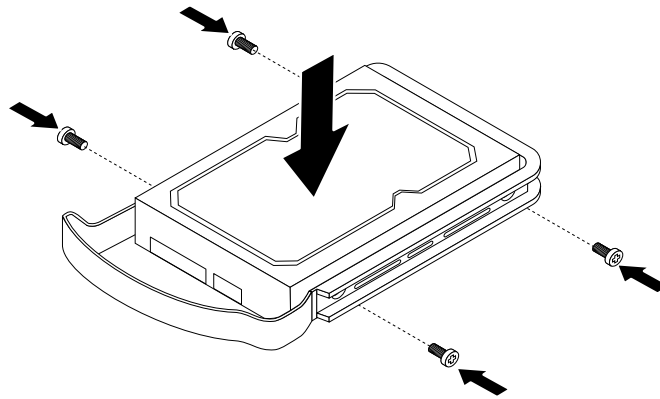

Figure 41. Securing the hard disk drive in the bracket by screws

- If you want to secure the hard disk drive in the bracket by retainers, align the holes in both sides of the hard disk drive with the corresponding holes in the bracket. Then, carefully install the retainers **1** on both sides to secure the hard disk drive in the bracket.

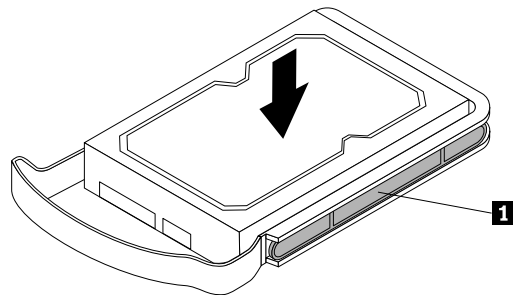

Figure 42. Securing the hard disk drive in the bracket by retainers

7. Push the hard disk drive to slide the bracket with the hard disk drive into the drive bay until it snaps into position.

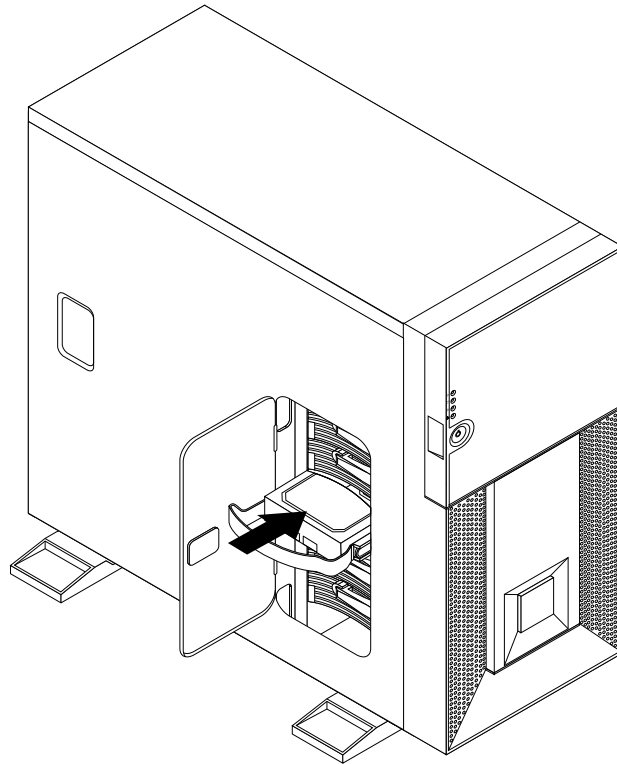

Figure 43. Sliding the non-hot-swap hard disk drive into the bay

8. Locate an available five-wire power connector and an available signal cable connector. Then, connect the power cable and the signal cable to the hard disk drive.

What to do next:

- To work with another piece of hardware, go to the appropriate section.
- To complete the installation, go to “Completing the parts replacement” on page 90. Then, you might need to check the hard disk drive status LEDs to make sure that the hard disk drive is operating correctly. Restart the server for the newly installed drive to be recognized. If the amber hard disk drive status LED is lit continuously, this indicates that the hard disk drive is faulty and must be replaced; if the green hard disk drive status LED is blinking, this indicates that the hard disk drive is operating correctly.

Note: If the server is configured for RAID operation using a RAID controller, you might have to reconfigure the disk arrays after you replace hard disk drives.

Installing or removing a PCI card

This section provides instructions on how to install or remove a PCI card.

The EMI integrity and cooling of the server are protected by having all drive bays and PCI card slots covered or occupied. When you install a drive or PCI card, save the EMC shield or drive bay filler from the drive bay or save the PCI card slot cover in the event that you later remove the device. An unoccupied drive bay or PCI card slot without cover, shield, filler, or any other protection might impact the EMI integrity and cooling of the server, which might result in overheating or component damage.

Note: The PCI cards are extremely sensitive to electrostatic discharge. Make sure that you read and understand “Handling static-sensitive devices” on page 22 first and carefully perform the operation.

Installing a PCI card

Attention:

Do not open your server or attempt any repair before reading and understanding the *Safety Information* and the *Warranty and Support Information* on the *ThinkServer Documentation DVD* that came with your product, and “Guidelines” on page 21. To obtain a copy of the publications, go to:
<http://www.lenovo.com/support>

This section provides instructions on how to install a PCI card.

To install a PCI card, do the following:

Note: Use any documentation that came with the PCI card and follow those instructions in addition to the instructions in this section.

1. Remove all media from the drives and turn off all attached devices and the server. Then, disconnect all power cords from electrical outlets and disconnect all cables that are connected to the server.
2. Remove the server cover. See “Removing the server cover” on page 23.
3. Lay the server on its side for easier operation.
4. Locate an appropriate PCI card slot on the system board. See “Locating parts on the system board” on page 15 to identify the types of PCI card slots for your server.
5. Remove the PCI card slot bracket by removing the screw that secures the bracket and then lift the bracket out of the chassis. Save the PCI card slot bracket in the event that you later remove the PCI card and need the bracket to cover the place.
6. Touch the static-protective package that contains the new PCI card to any unpainted surface on the outside of the server. Then, remove the new PCI card from the package.

Note: Carefully handle the PCI card by its edges.

7. Position the new PCI card on the PCI card slot which you have removed the slot bracket in step 5 on page 54. Then, press the PCI card straight down until it is securely seated into the slot. Install the screw to secure the PCI card in place.

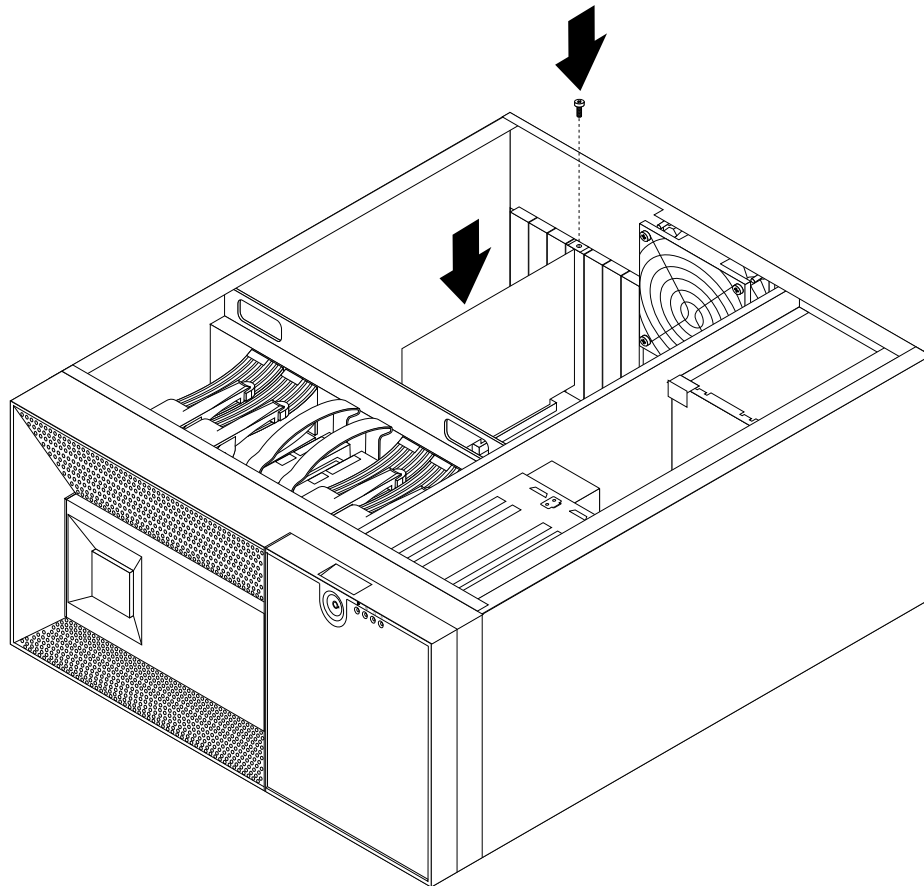

Figure 44. Installing a PCI card

8. Depending on the type of the PCI card, you might need to connect any required cables to the PCI card.

What to do next:

- To work with another piece of hardware, go to the appropriate section.
- To complete the installation, go to “Completing the parts replacement” on page 90.

Removing a PCI card

Attention:
Do not open your server or attempt any repair before reading and understanding the *Safety Information* and the *Warranty and Support Information* on the *ThinkServer Documentation DVD* that came with your product, and “Guidelines” on page 21. To obtain a copy of the publications, go to:
<http://www.lenovo.com/support>

This section provides instructions on how to remove a PCI card.

To remove a PCI card, do the following:

Note: Use any documentation that came with the PCI card and follow those instructions in addition to the instructions in this section.

1. Remove all media from the drives and turn off all attached devices and the server. Then, disconnect all power cords from electrical outlets and disconnect all cables that are connected to the server.
2. Remove the server cover. See “Removing the server cover” on page 23.
3. Lay the server on its side for easier operation.
4. Locate the PCI card you want to remove. Then, depending on the type of the PCI card, you might need to disconnect any cables from the PCI card or the system board.
5. Remove the screw that secures the PCI card. Then, grasp the PCI card by the edges and carefully pull it out of the PCI card slot. If necessary, alternate moving each side of the PCI card a small and equal amount until it is completely removed from the slot.

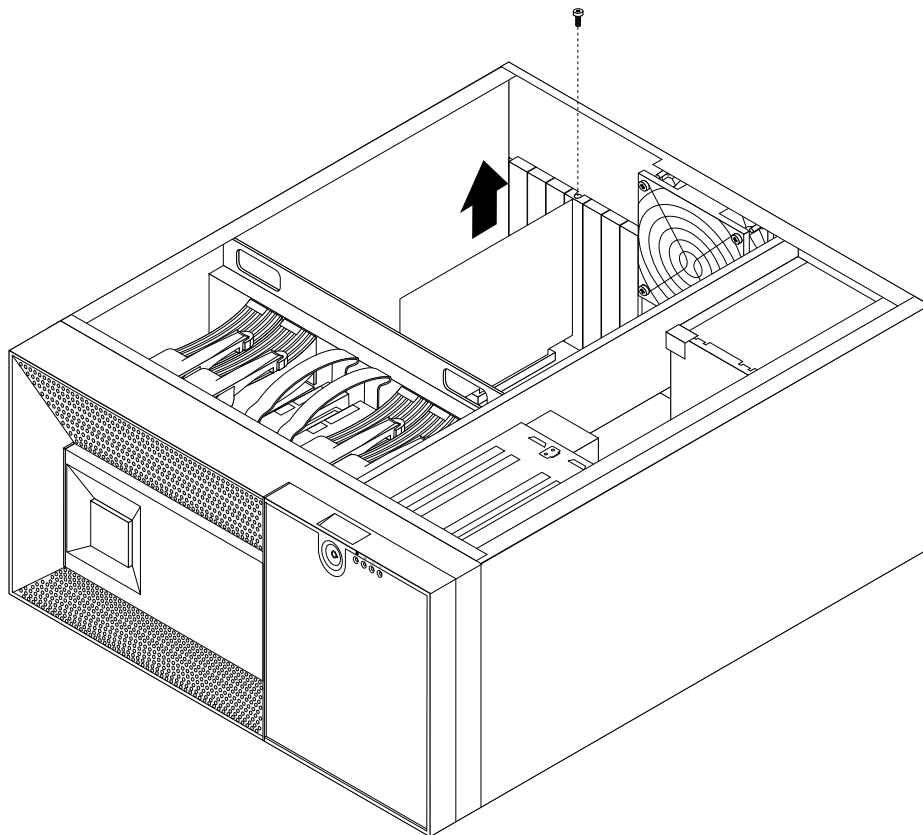

Figure 45. Removing a PCI card

If you are instructed to return the removed PCI card to the manufacturer, follow all packaging instructions and use any packaging materials that are supplied to you for shipping.

What to do next:

- To work with another piece of hardware, go to the appropriate section.
- To complete the removal procedure, go to “Completing the parts replacement” on page 90.

Installing or removing the Ethernet card

This section provides instructions on how to install or remove the Ethernet card.

Installing the Ethernet card

Attention:

Do not open your server or attempt any repair before reading and understanding the *Safety Information* and the *Warranty and Support Information* on the *ThinkServer Documentation DVD* that came with your product, and “Guidelines” on page 21. To obtain a copy of the publications, go to:
<http://www.lenovo.com/support>

This section provides instructions on how to install the Ethernet card and how to install the Ethernet card driver on Windows operating systems. Use any documentation that came with the Ethernet card and follow those instructions in addition to the instructions in this section.

To install the Ethernet card, do the following:

1. Remove all media from the drives and turn off all attached devices and the server. Then, disconnect all power cords from electrical outlets and disconnect all cables that are connected to the server.
2. Remove the server cover. See “Removing the server cover” on page 23.
3. Lay the server on its side for easier operation.
4. Touch the static-protective package that contains the Ethernet card to any unpainted surface on the outside of the server. Then, remove the Ethernet card from the package.
5. The Ethernet card is a kind of PCI card. See “Installing a PCI card” on page 54 and follow those instructions to install the Ethernet card.

What to do next:

- To work with another piece of hardware, go to the appropriate section.
- To complete the installation, go to “Completing the parts replacement” on page 90.

On Linux operating systems, you do not need to install any device driver for the Ethernet card; on Windows operating systems, you need to install the device driver for the Ethernet card. To install the device driver on Windows operating systems, do the following:

1. Save any open documents and exit all applications.
2. Insert the *ThinkServer EasyStartup* DVD that came with your server into the DVD drive.

Note: You do not need to use the driver disc that came with the Ethernet card.

3. Right-click My Computer and select **Properties**. The System Properties window opens.
4. On the **Hardware** tab, click the **Device Manager** button. The Device Manager window opens.
5. Expand the **Network adapters** and then right-click one of the Ethernet cards (PRO/1000PT or the yellow question mark).
6. Select **Update Driver...** The Hardware Update Wizard program opens.
7. Select **Install the software automatically (Recommended)** and click **Next** to continue.
8. Follow the instructions on the screen.

Removing the Ethernet card

Attention:

Do not open your server or attempt any repair before reading and understanding the *Safety Information* and the *Warranty and Support Information* on the *ThinkServer Documentation DVD* that came with your product, and “Guidelines” on page 21. To obtain a copy of the publications, go to:
<http://www.lenovo.com/support>

This section provides instructions on how to remove the Ethernet card. Use any documentation that came with the Ethernet card and follow those instructions in addition to the instructions in this section.

To remove the Ethernet card, do the following:

1. Remove all media from the drives and turn off all attached devices and the server. Then, disconnect all power cords from electrical outlets and disconnect all cables that are connected to the server.
2. Remove the server cover. See “Removing the server cover” on page 23.
3. Lay the server on its side for easier operation.
4. The Ethernet card is a kind of PCI card. See “Removing a PCI card” on page 55 and follow those instructions to remove the Ethernet card.
5. If you are instructed to return the removed Ethernet card to the manufacturer, follow all packaging instructions and use any packaging materials that are supplied to you for shipping.

What to do next:

- To work with another piece of hardware, go to the appropriate section.
- To complete the removal procedure, go to “Completing the parts replacement” on page 90.

Installing or removing the ThinkServer TD230 SATA RAID 5 Upgrade

This section provides instructions on how to install or remove the ThinkServer TD230 SATA RAID 5 Upgrade (hereafter called the RAID 5 key). The RAID 5 key is an activation key, which you can install on the system board to enable the RAID 5 configuration function of the onboard SATA RAID for your server.

Installing the RAID 5 key

Attention:

Do not open your server or attempt any repair before reading and understanding the *Safety Information* and the *Warranty and Support Information* on the *ThinkServer Documentation DVD* that came with your product, and “Guidelines” on page 21. To obtain a copy of the publications, go to:
<http://www.lenovo.com/support>

This section provides instructions on how to install the RAID 5 key.

To install the RAID 5 key, do the following:

Attention: Electrostatic discharge (ESD) can damage the RAID 5 key. Always ground yourself and use a ground strap before touching the option. Perform the following procedure at an ESD-safe workstation.

1. Remove all media from the drives and turn off all attached devices and the server. Then, disconnect all power cords from electrical outlets and disconnect all cables that are connected to the server.
2. Remove the server cover. See “Removing the server cover” on page 23.
3. Lay the server on its side for easier operation.
4. Touch the static-protective package that contains the RAID 5 key to any unpainted surface on the outside of the server. Then, remove the RAID 5 key from the package.

5. Locate the SATA key connector on the system board. See “Locating parts on the system board” on page 15. Then, install the RAID 5 key into the SATA key connector.

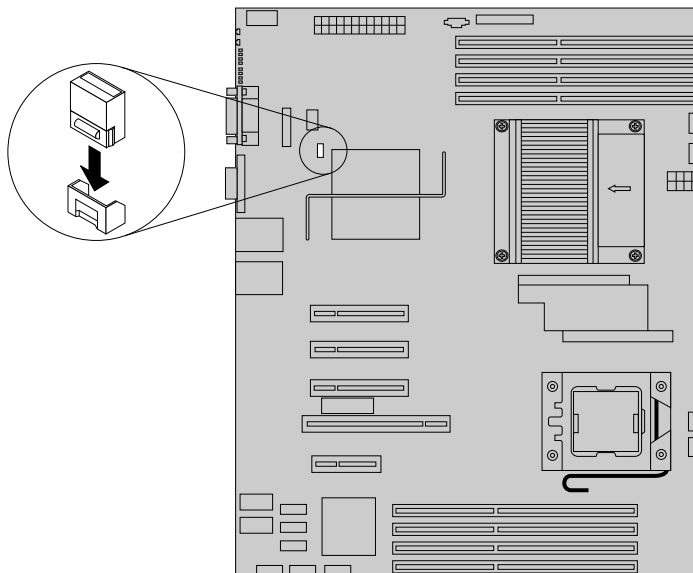

Figure 46. Installing the RAID 5 key

What to do next:

- To work with another piece of hardware, go to the appropriate section.
- To complete the installation, go to “Completing the parts replacement” on page 90. Then, refer to Chapter 6 “Configuring the server” on page 95 for information about RAID configuration.

Removing the RAID 5 key

Attention:

Do not open your server or attempt any repair before reading and understanding the *Safety Information* and the *Warranty and Support Information* on the *ThinkServer Documentation DVD* that came with your product, and “Guidelines” on page 21. To obtain a copy of the publications, go to:
<http://www.lenovo.com/support>

This section provides instructions on how to remove the RAID 5 key from the system board. If you remove the RAID 5 key, the RAID 5 configuration function of the onboard SATA RAID becomes unavailable. However, the RAID 5 configuration function of the ThinkServer 9240-8i RAID 0/1 Adapter is still available if you have installed the ThinkServer 9240-8i RAID 5 Upgrade Key on the adapter. See “Installing the 9240-8i RAID 5 key” on page 60.

To remove the RAID 5 key, do the following:

Attention: Electrostatic discharge (ESD) can damage the RAID 5 key. Always ground yourself and use a ground strap before touching the option. Perform the following procedure at an ESD-safe workstation.

1. Remove all media from the drives and turn off all attached devices and the server. Then, disconnect all power cords from electrical outlets and disconnect all cables that are connected to the server.
2. Remove the server cover. See “Removing the server cover” on page 23.
3. Lay the server on its side for easier operation.

4. Remove the RAID 5 key from the SATA key connector on the system board. See “Locating parts on the system board” on page 15.

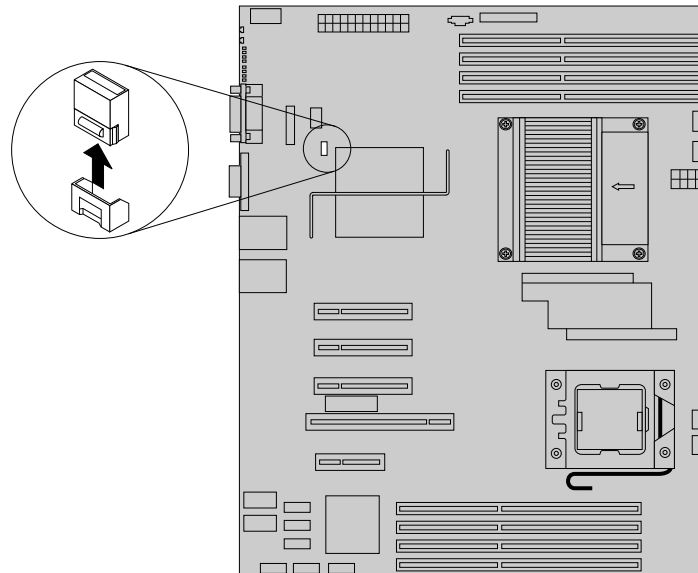

Figure 47. Removing the RAID 5 key

5. If you are instructed to return the removed RAID 5 key to the manufacturer, follow all packaging instructions and use any packaging materials that are supplied to you for shipping.

What to do next:

- To work with another piece of hardware, go to the appropriate section.
- To complete the removal procedure, go to “Completing the parts replacement” on page 90.

Installing or removing the ThinkServer 9240-8i RAID 5 Upgrade Key

This section provides instructions on how to install or remove the ThinkServer 9240-8i RAID 5 Upgrade Key (hereafter called the 9240-8i RAID 5 key). If your server has a ThinkServer 9240-8i RAID 0/1 Adapter installed and you want to enable the RAID 5 configuration function for this adapter, you need to install the 9240-8i RAID 5 key on the adapter.

Installing the 9240-8i RAID 5 key

Attention:

Do not open your server or attempt any repair before reading and understanding the *Safety Information* and the *Warranty and Support Information* on the *ThinkServer Documentation DVD* that came with your product, and “Guidelines” on page 21. To obtain a copy of the publications, go to:
<http://www.lenovo.com/support>

This section provides instructions on how to install the 9240-8i RAID 5 key.

To install the 9240-8i RAID 5 key, do the following:

Attention: Electrostatic discharge (ESD) can damage the 9240-8i RAID 5 key. Always ground yourself and use a ground strap before touching the option. Perform the following procedure at an ESD-safe workstation.

1. Remove all media from the drives and turn off all attached devices and the server. Then, disconnect all power cords from electrical outlets and disconnect all cables that are connected to the server.

2. Remove the server cover. See “Removing the server cover” on page 23.
3. Lay the server on its side for easier operation.
4. Touch the static-protective package that contains the 9240-8i RAID 5 key to any unpainted surface on the outside of the server. Then, remove the 9240-8i RAID 5 key from the package.
5. Install the 9240-8i RAID 5 key to the ThinkServer 9240-8i RAID 0/1 Adapter, as shown:

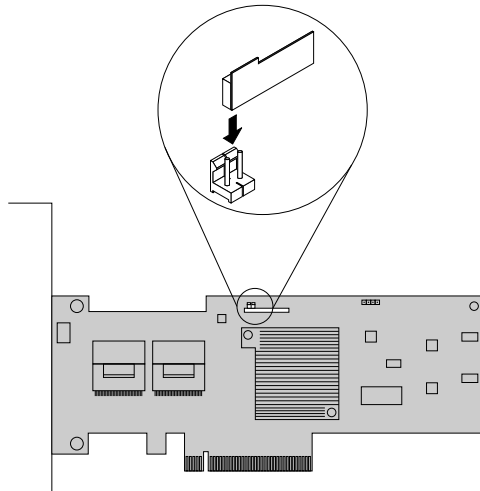

Figure 48. Installing the 9240-8i RAID 5 key

What to do next:

- To work with another piece of hardware, go to the appropriate section.
- To complete the installation, go to “Completing the parts replacement” on page 90. Then, refer to Chapter 6 “Configuring the server” on page 95 for information about RAID configuration.

Removing the 9240-8i RAID 5 key

Attention:

Do not open your server or attempt any repair before reading and understanding the *Safety Information* and the *Warranty and Support Information* on the *ThinkServer Documentation DVD* that came with your product, and “Guidelines” on page 21. To obtain a copy of the publications, go to:
<http://www.lenovo.com/support>

This section provides instructions on how to remove the 9240-8i RAID 5 key from the ThinkServer 9240-8i RAID 0/1 Adapter. If you remove the 9240-8i RAID 5 key, the RAID 5 configuration function of the ThinkServer 9240-8i RAID 0/1 Adapter becomes unavailable. However, the RAID 5 configuration function of the onboard SATA RAID is still available if you have installed the RAID 5 Key on the system board. See “Installing the RAID 5 key” on page 58.

To remove the 9240-8i RAID 5 key, do the following:

Attention: Electrostatic discharge (ESD) can damage the 9240-8i RAID 5 key. Always ground yourself and use a ground strap before touching the option. Perform the following procedure at an ESD-safe workstation.

1. Remove all media from the drives and turn off all attached devices and the server. Then, disconnect all power cords from electrical outlets and disconnect all cables that are connected to the server.
2. Remove the server cover. See “Removing the server cover” on page 23.
3. Lay the server on its side for easier operation.

4. Remove the ThinkServer 9240-8i RAID 0/1 Adapter. See “Removing the RAID card” on page 69 and follow those instructions to remove the ThinkServer 9240-8i RAID 0/1 Adapter.
5. Remove the 9240-8i RAID 5 key from the ThinkServer 9240-8i RAID 0/1 Adapter.

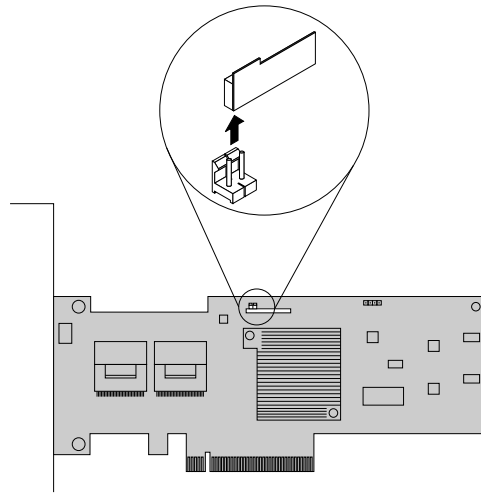

Figure 49. Removing the 9240-8i RAID 5 key

6. If you are instructed to return the removed 9240-8i RAID 5 key to the manufacturer, follow all packaging instructions and use any packaging materials that are supplied to you for shipping.

What to do next:

- To work with another piece of hardware, go to the appropriate section.
- To complete the removal procedure, go to “Completing the parts replacement” on page 90.

Installing or removing the ThinkServer Remote Management Module 3

This section provides product information about the ThinkServer Remote Management Module 3 (hereafter called the RMM3) and instructions on how to install or remove the RMM3 option.

About the RMM3

The RMM3 is a 1.23-inch x 2.30-inch printed circuit board.

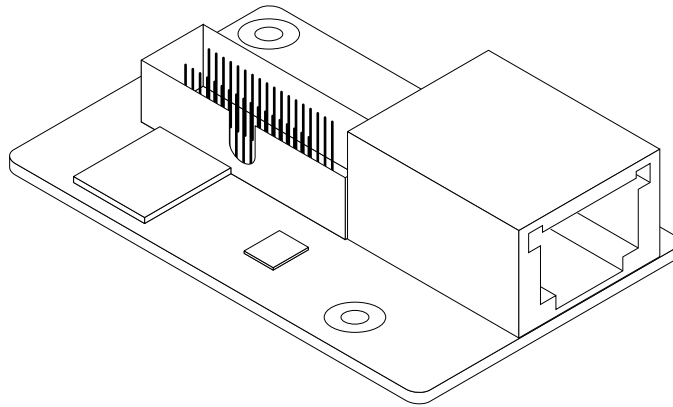

Figure 50. RMM3

The RMM3 is a kind of add-on card which offers convenient, remote KVM (keyboard, video, and mouse) access and control through the LAN or Internet. It captures, digitizes, and compresses videos and transmits the videos with keyboard and mouse signals to and from a remote computer. You can use the RMM3 to gain location-independent remote access to respond to critical incidents and to undertake necessary maintenance. In addition, the RMM3 offers integrated remote power management using intelligent platform management interface (IPMI). Therefore, working as an integrated solution in your server, the RMM3 provides an increased level of manageability over the basic server management available to the system board.

The RMM3 option package contains the following items:

- A ThinkServer Remote Management Module 3 option
- A plastic bag containing a slot bracket, a ribbon cable, three screws, and three plastic standoffs

Installing the RMM3

Attention:

Do not open your server or attempt any repair before reading and understanding the *Safety Information* and the *Warranty and Support Information* on the *ThinkServer Documentation DVD* that came with your product, and “Guidelines” on page 21. To obtain a copy of the publications, go to:

<http://www.lenovo.com/support>

This section provides instructions on how to install the RMM3 in your server. You can get an increased level of manageability over the basic server management available to the system board by installing the RMM3 option. See “About the RMM3” on page 63 for the product information.

To install the RMM3, do the following:

Attention: Electrostatic discharge (ESD) can damage the RMM3. Always ground yourself and use a ground strap before touching the option. Perform the following procedure at an ESD-safe workstation.

1. Remove all media from the drives and turn off all attached devices and the server. Then, disconnect all power cords from electrical outlets and disconnect all cables that are connected to the server. Wait three to five minutes to let the server cool before removing the server cover.
2. Remove the server cover. See “Removing the server cover” on page 23.
3. Lay the server on its side for easier operation.

4. Locate the RMM3 connector on the system board. See “Locating parts on the system board” on page 15.
5. Remove the corresponding PCI card slot bracket by removing the screw that secures the bracket. Save the PCI card slot bracket in the event that you later remove the RMM3 and need the bracket to cover the place.

Note: Carefully place the removed screw aside. You will need the screw when installing the RMM3.

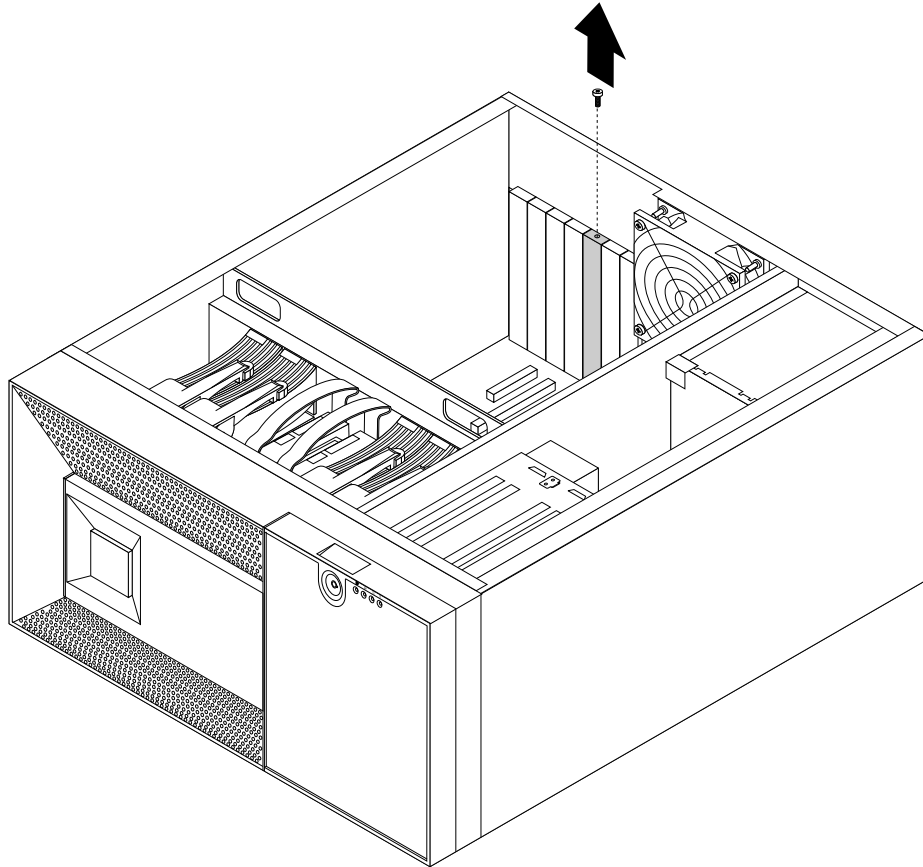

Figure 51. Removing the PCI card slot bracket for the RMM3 connector

6. Touch the static-protective package that contains the RMM3 to any unpainted surface on the outside of the server. Then, remove the RMM3 from the package.
7. Make a note of the Media Access Controller (MAC) address of the RMM3. This information is on a label attached to the RMM3 and might be used later for several software configurations. Keeping a record at this moment might eliminate the needs to reopen the server cover later.

8. Attach the RMM3 to the slot bracket that came with the option package so that the two screw holes in the slot bracket are aligned with the corresponding holes in the RMM3. Then, install the two screws that came with the option package to secure the RMM3 to the slot bracket.

Notes:

- a. There are three screws in the option package and you only need to use two of them to secure the RMM3 to the slot bracket. The extra one is a backup screw.
- b. For easier operation, you might need to attach a plastic standoff that came with the option package to each screw before installing the screw.

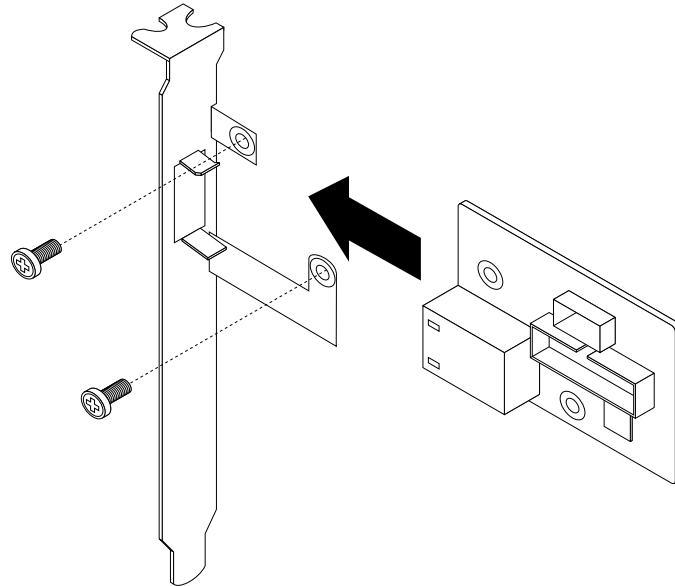

Figure 52. Installing the RMM3 on the slot bracket

9. Insert the slot bracket with RMM3 into the position for the PCI card slot bracket you have removed. Then, secure the slot bracket with RMM3 in place by installing the screw that you have removed in step 5 on page 64.

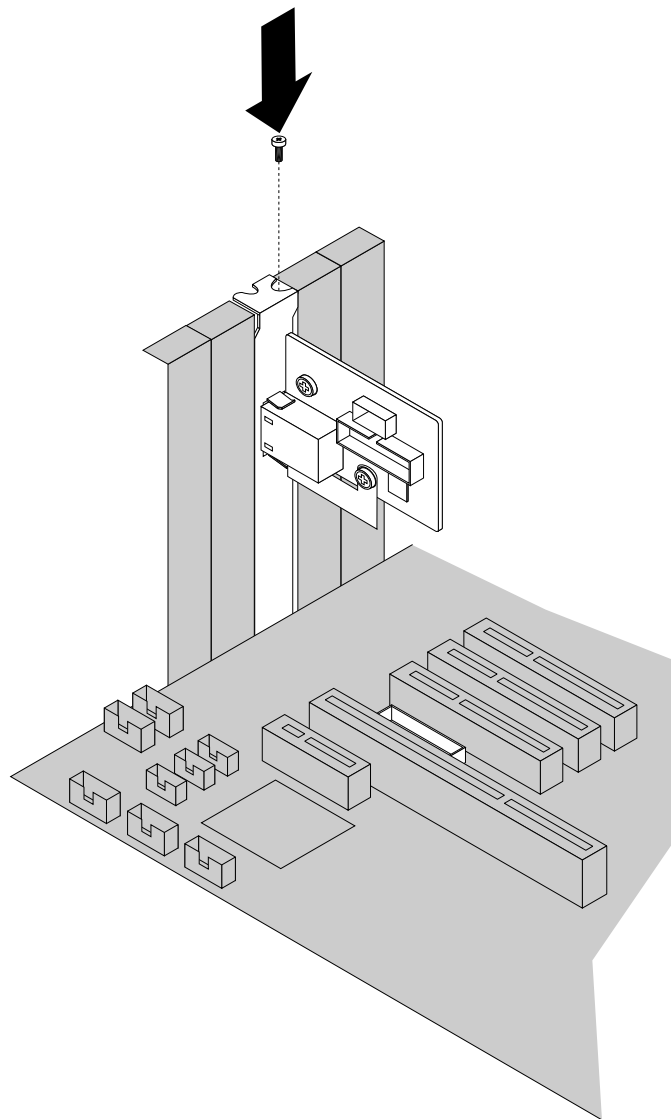

Figure 53. Installing the slot bracket with RMM3

10. Remove the ribbon cable from the option package. Connect one end of the ribbon cable to the RMM3 connector on the system board. See “Locating parts on the system board” on page 15. Then, connect the other end of the ribbon cable to the connector on the RMM3.

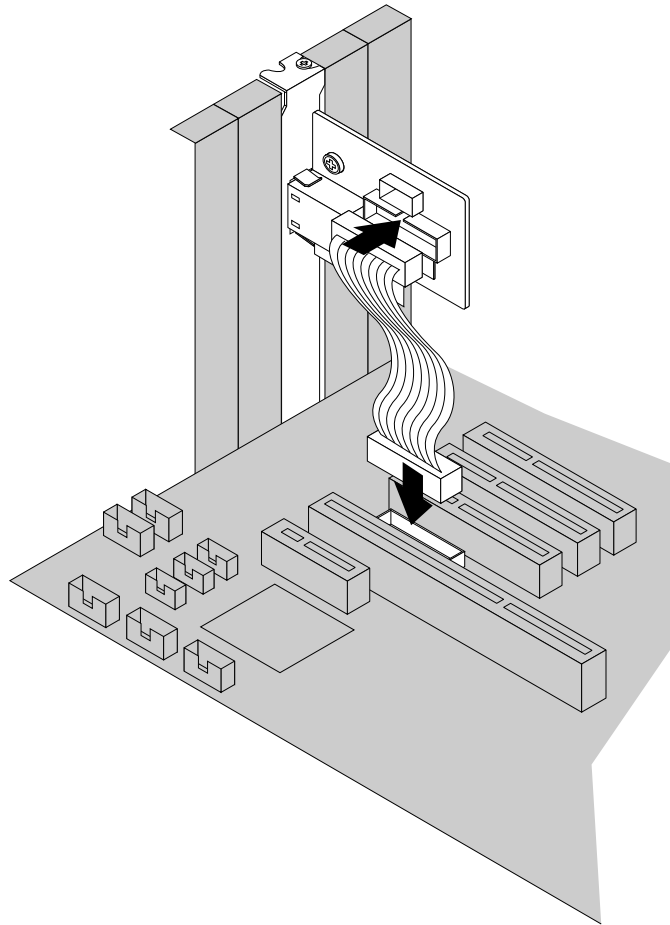

Figure 54. Connecting the ribbon cable

What to do next:

- To work with another piece of hardware, go to the appropriate section.
- To complete the installation, go to “Completing the parts replacement” on page 90. After installing the RMM3 and restarting the server, connect a network cable to the RMM3 network interface controller, then configure the RMM3 by referring to the *ThinkServer Remote Management User Guide* on the *ThinkServer Documentation DVD* that came with your product.

Removing the RMM3

Attention:

Do not open your server or attempt any repair before reading and understanding the *Safety Information* and the *Warranty and Support Information* on the *ThinkServer Documentation DVD* that came with your product, and “Guidelines” on page 21. To obtain a copy of the publications, go to:
<http://www.lenovo.com/support>

This section provides instructions on how to remove the RMM3. If you have installed a RMM3 option in your server, you can perform the following procedure when you want to remove this option.

To remove the RMM3, do the following:

1. Remove all media from the drives and turn off all attached devices and the server. Then, disconnect all power cords from electrical outlets and disconnect all cables that are connected to the server. Wait three to five minutes to let the server cool before removing the server cover.
2. Remove the server cover. See “Removing the server cover” on page 23.
3. Lay the server on its side for easier operation.
4. Locate the RMM3 in your server. Then, disconnect the ribbon cable from the RMM3 connector on the system board. See “Locating parts on the system board” on page 15. Remove the screw that secures the slot bracket with RMM3. Then, carefully lift the slot bracket with RMM3 out of the server.

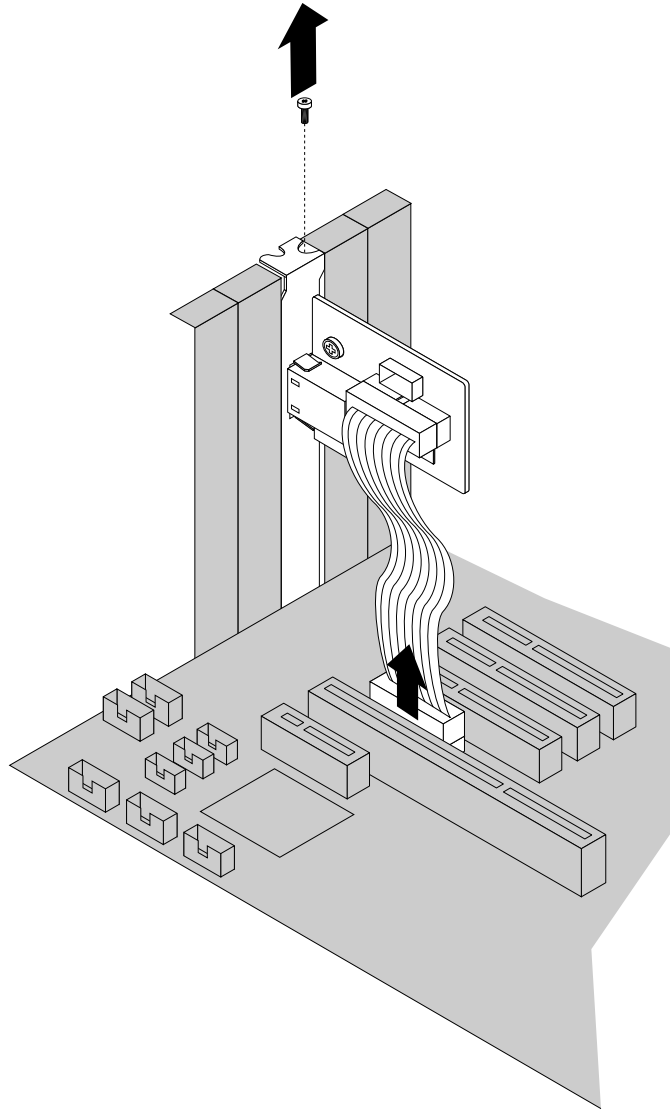

Figure 55. Disconnecting the ribbon cable and removing the slot bracket with RMM3

5. Put the removed RMM3 kit (slot bracket with RMM3 and ribbon cable) into its original package. If necessary, disconnect the ribbon cable from the RMM3.
6. If you are instructed to return the removed RMM3 kit to the manufacturer, follow all packaging instructions and use any packaging materials that are supplied to you for shipping.

What to do next:

- To work with another piece of hardware, go to the appropriate section.
- To complete the removal procedure, go to “Completing the parts replacement” on page 90.

Installing, removing, or replacing hardware devices

This section provides instructions on how to install, remove, or replace hardware devices for your server. You can maintain your server by replacing the failing hardware devices. If you are replacing a hardware device, perform the removal procedure and then perform the installation procedure for the hardware device that you want to replace.

Removing or installing the ThinkServer 9240-8i RAID 0/1 Adapter

This section provides instructions on how to remove or install the ThinkServer 9240-8i RAID 0/1 Adapter (hereafter called the RAID card).

Note: This section only applies to server models with hot-swap hard disk drives.

Removing the RAID card

Attention:

Do not open your server or attempt any repair before reading and understanding the *Safety Information* and the *Warranty and Support Information* on the *ThinkServer Documentation DVD* that came with your product, and “Guidelines” on page 21. To obtain a copy of the publications, go to:
<http://www.lenovo.com/support>

This section provides instructions on how to remove the RAID card. If you remove the RAID card, you cannot configure RAID using the RAID card and you will lose all the current RAID configuration based on the RAID card.

Note: This section only applies to server models with hot-swap hard disk drives.

To remove the RAID card, do the following:

1. Remove all media from the drives and turn off all attached devices and the server. Then, disconnect all power cords from electrical outlets and disconnect all cables that are connected to the server.
2. Remove the server cover. See “Removing the server cover” on page 23.
3. Lay the server on its side for easier operation.
4. Locate the RAID card. The RAID card is installed into one of the PCI Express x8 slots on the system board (callout **31** in Figure 7 “Locating major parts on the system board” on page 15). See “Locating parts on the system board” on page 15.
5. Remove any parts and disconnect any cables that might prevent your access to the RAID card.
6. Disconnect the mini SAS signal cable from the RAID card.
7. The RAID card is a kind of PCI card. See “Removing a PCI card” on page 55 and follow those instructions to remove the RAID card.

Note: Depending on your RAID card, if necessary, remove the 9240-8i RAID 5 key from the RAID card.

8. If you are instructed to return the removed RAID card to the manufacturer, follow all packaging instructions and use any packaging materials that are supplied to you for shipping.

What to do next:

- To work with another piece of hardware, go to the appropriate section.
- To complete the removal procedure, go to “Completing the parts replacement” on page 90.

Installing the RAID card

Attention:

Do not open your server or attempt any repair before reading and understanding the *Safety Information* and the *Warranty and Support Information* on the *ThinkServer Documentation DVD* that came with your product, and “Guidelines” on page 21. To obtain a copy of the publications, go to:
<http://www.lenovo.com/support>

This section provides instructions on how to install the RAID card.

Note: This section only applies to server models with hot-swap hard disk drives.

To install the RAID card, do the following:

1. Remove all media from the drives and turn off all attached devices and the server. Then, disconnect all power cords from electrical outlets and disconnect all cables that are connected to the server.
2. Remove the server cover. See “Removing the server cover” on page 23.
3. Lay the server on its side for easier operation.
4. The RAID card should be installed into the appropriate PCI Express x8 slot on the system board (callout **31** in Figure 7 “Locating major parts on the system board” on page 15). See “Locating parts on the system board” on page 15.
5. Touch the static-protective package that contains the RAID card to any unpainted surface on the outside of the server. Then, remove the RAID card from the package.
6. Depending on your RAID card, you might need to install the 9240-8i RAID 5 key on the RAID card. See “Installing the 9240-8i RAID 5 key” on page 60 and follow those instructions to install the 9240-8i RAID 5 key.
7. Connect the mini SAS signal cable to the mini SAS signal cable connector 0 on the RAID card. See Figure 56 “Connecting the mini SAS signal cables” on page 71.

Note: The mini SAS signal cable length is 880 mm (34.65 inches).

8. The RAID card is a kind of PCI card. See “Installing a PCI card” on page 54 and follow those instructions to install the RAID card. Take caution when handling the mini SAS signal cable to avoid damaging the mini SAS signal cable connector.

- Connect the mini SAS signal cables (port 0 to port 3) to the corresponding SATA/SAS signal connectors (connector 0 to connector 3) on the hot-swap hard disk drive backplanes. See “Locating connectors on the hot-swap hard disk drive backplanes” on page 18.

Note: Each mini SAS signal cable might have a label attached. The number on the label indicates the port number.

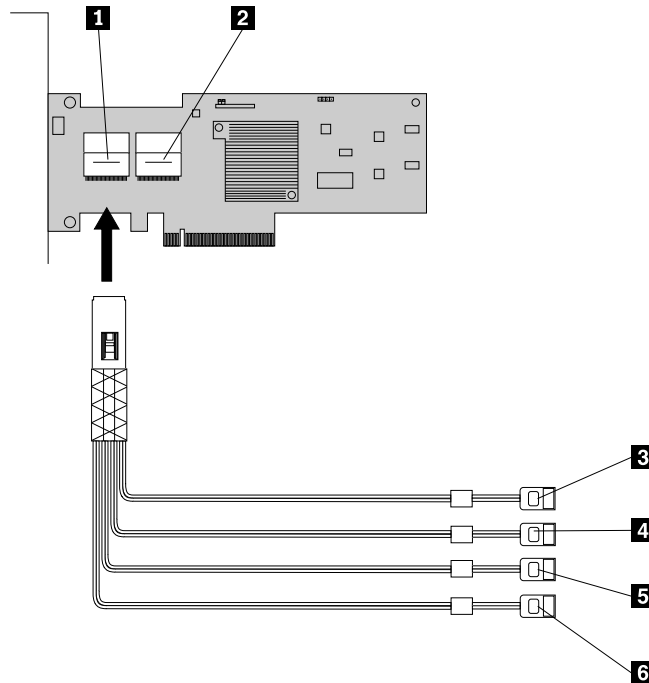

Figure 56. Connecting the mini SAS signal cables

- | | |
|--|---|
| 1 Mini SAS signal cable connector 0 | 4 Mini SAS signal cable - port 1 |
| 2 Mini SAS signal cable connector 1 | 5 Mini SAS signal cable - port 2 |
| 3 Mini SAS signal cable - port 0 | 6 Mini SAS signal cable - port 3 |

What to do next:

- To work with another piece of hardware, go to the appropriate section.
- To complete the installation, go to “Completing the parts replacement” on page 90. Then, refer to Chapter 6 “Configuring the server” on page 95 for information about RAID configuration.

Removing or installing the heat sink and fan assembly

This section provides instructions on how to remove or install the heat sink and fan assembly.

Removing the heat sink and fan assembly

Attention:
Do not open your server or attempt any repair before reading and understanding the *Safety Information* and the *Warranty and Support Information* on the *ThinkServer Documentation DVD* that came with your product, and “Guidelines” on page 21. To obtain a copy of the publications, go to:
<http://www.lenovo.com/support>

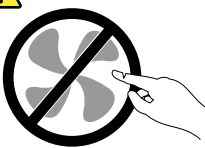

This section provides instructions on how to remove the heat sink and fan assembly.

 **DANGER**

Hazardous moving parts. Keep fingers and other body parts away.

CAUTION:

  **The heat sink and fan assembly might be very hot. Turn off the server and wait three to five minutes to let the server cool before removing the server cover.**

To remove the heat sink and fan assembly, do the following:

1. Remove all media from the drives and turn off all attached devices and the server. Then, disconnect all power cords from electrical outlets and disconnect all cables that are connected to the server.
2. Remove the server cover. See “Removing the server cover” on page 23.
3. Locate the heat sink and fan assembly. See “Locating server components” on page 14.

Note: If a second microprocessor is installed in the server, there will also be a heat sink and fan assembly installed above the second microprocessor.

4. Lay the server on its side for easier operation.
5. Depending on which heat sink and fan assembly you are removing, do one of the following:

- If you are removing the heat sink and fan assembly for microprocessor 1, disconnect the heat sink and fan assembly cable from the system fan 2 connector on the system board. See “Locating parts on the system board” on page 15. Then, remove the four screws **1** that secure the heat sink and fan assembly.

Note: Carefully remove the four screws from the system board to avoid any possible damage. The four screws are integrated parts of the heat sink and fan assembly and they cannot be removed from the heat sink and fan assembly.

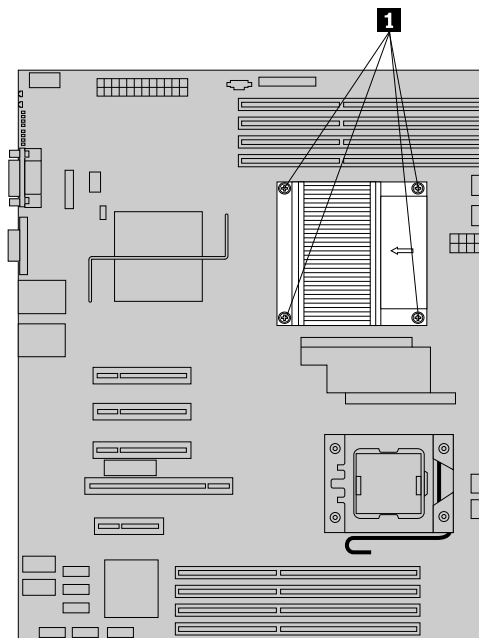

Figure 57. Screws that secure the heat sink and fan assembly for microprocessor 1

- If you have installed a second microprocessor and you are removing the heat sink and fan assembly for microprocessor 2, disconnect the heat sink and fan assembly cable from the system fan 1 connector on the system board. See “Locating parts on the system board” on page 15. Then, remove the four screws **1** that secure the heat sink and fan assembly.

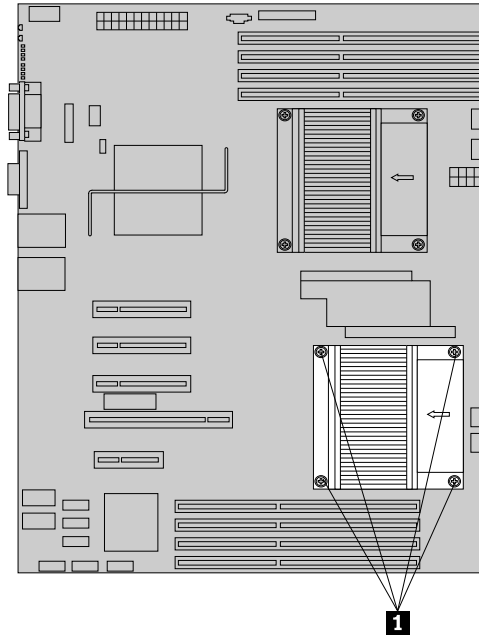

Figure 58. Screws that secure the heat sink and fan assembly for microprocessor 2

6. Lift the heat sink and fan assembly off the system board.

Notes:

- a. You might have to gently twist the heat sink and fan assembly to free it from the microprocessor.
- b. When handling the heat sink and fan assembly, do not touch the thermal grease **1** on the bottom of it.

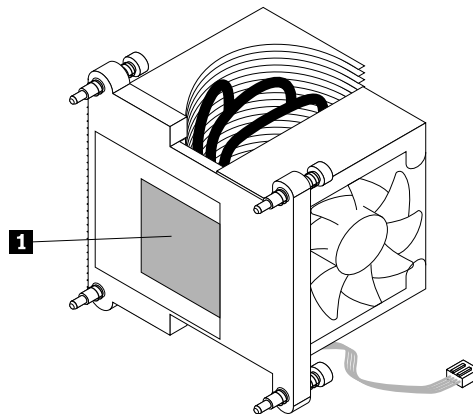

Figure 59. Heat sink and fan assembly

7. If you are instructed to return the removed heat sink and fan assembly to the manufacturer, follow all packaging instructions and use any packaging materials that are supplied to you for shipping.

What to do next:

- To work with another piece of hardware, go to the appropriate section.
- To install the heat sink and fan assembly, see “Installing the heat sink and fan assembly” on page 75.

Installing the heat sink and fan assembly**Attention:**

Do not open your server or attempt any repair before reading and understanding the *Safety Information* and the *Warranty and Support Information* on the *ThinkServer Documentation DVD* that came with your product, and “Guidelines” on page 21. To obtain a copy of the publications, go to:
<http://www.lenovo.com/support>

This section provides instructions on how to install the heat sink and fan assembly.

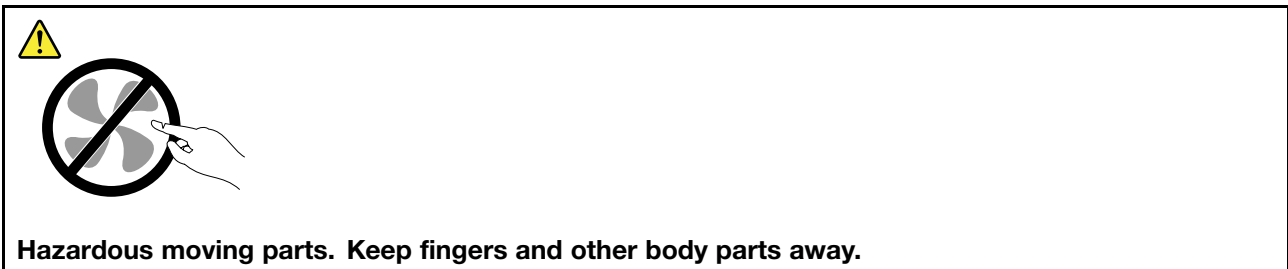
**CAUTION:**

The heat sink and microprocessor might be very hot. Turn off the server and wait three to five minutes to let the server cool before removing the server cover.

To install the heat sink and fan assembly, do the following:

1. Remove all media from the drives and turn off all attached devices and the server. Then, disconnect all power cords from electrical outlets and disconnect all cables that are connected to the server.
2. Remove the server cover. See “Removing the server cover” on page 23.
3. Lay the server on its side for easier operation.

4. Touch the static-protective package that contains the heat sink and fan assembly to any unpainted surface on the outside of the server. Then, remove the heat sink and fan assembly from the package.

Note: When handling the heat sink and fan assembly, do not touch the thermal grease **1** on the bottom of it.

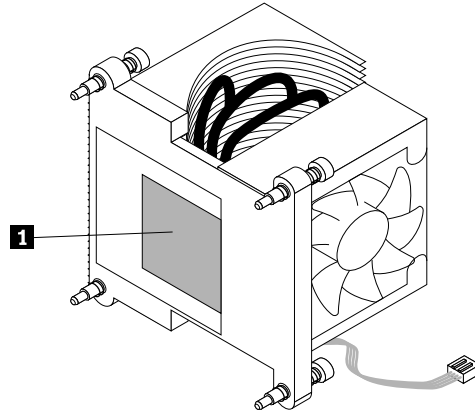
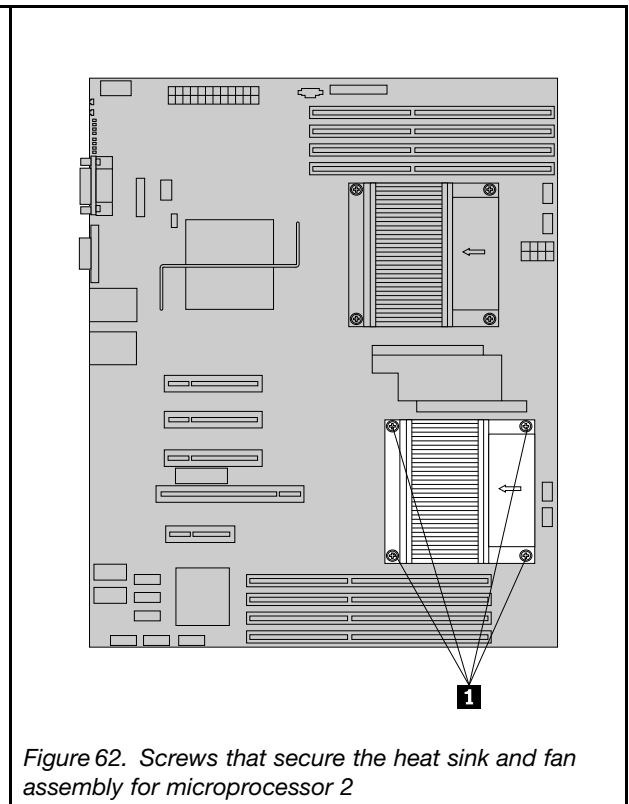
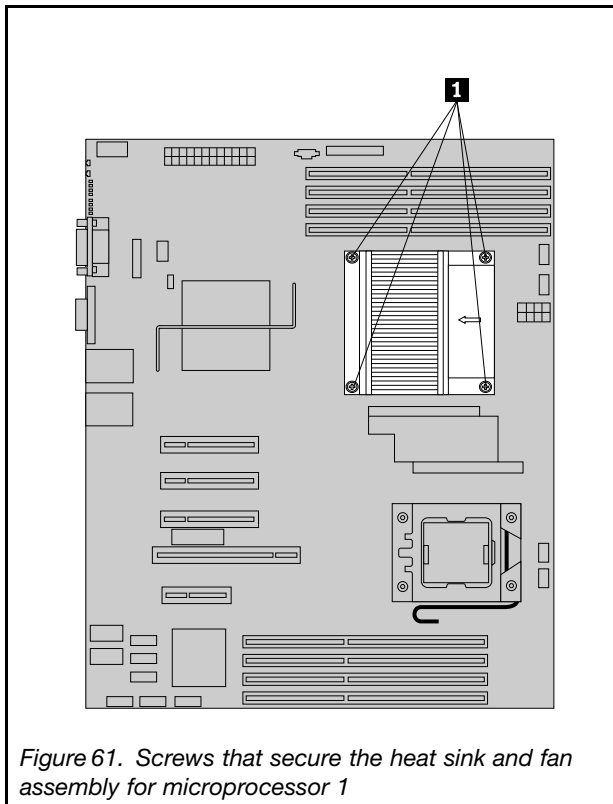

Figure 60. Heat sink and fan assembly

- Place the heat sink and fan assembly on the system board so that the four screws on the heat sink and fan assembly are aligned with the corresponding mounting studs on the system board. Make sure that you properly place the heat sink and fan assembly so that you can easily connect the heat sink and fan assembly cable to the system fan 2 connector (if the heat sink and fan assembly is for microprocessor 1) or the system fan 1 connector (if the heat sink and fan assembly is for microprocessor 2) on the system board. See “Locating parts on the system board” on page 15.

Note: Note the orientation of the heat sink and fan assembly by referring to the arrow label on the top of the heat sink and fan assembly. The arrow, which indicates air flow, should point to the rear of the chassis.



- Alternate tightening each screw a small and equal amount until the heat sink and fan assembly is secured to the system board. Do not over-tighten the screws.
- Connect the heat sink and fan assembly cable to the system fan 2 connector (if the heat sink and fan assembly is for microprocessor 1) or the system fan 1 connector (if the heat sink and fan assembly is for microprocessor 2) on the system board. See “Locating parts on the system board” on page 15.

What to do next:

- To work with another piece of hardware, go to the appropriate section.
- To complete the installation, go to “Completing the parts replacement” on page 90.

Removing or installing a front fan

This section provides instructions on how to remove or install a front fan.

Removing a front fan

Attention:

Do not open your server or attempt any repair before reading and understanding the *Safety Information* and the *Warranty and Support Information* on the *ThinkServer Documentation DVD* that came with your product, and “Guidelines” on page 21. To obtain a copy of the publications, go to:
<http://www.lenovo.com/support>

This section provides instructions on how to remove a front fan.



Hazardous moving parts. Keep fingers and other body parts away.

To remove a front fan, do the following:

1. Remove all media from the drives and turn off all attached devices and the server. Then, disconnect all power cords from electrical outlets and disconnect all cables that are connected to the server.
2. Remove the server cover. See “Removing the server cover” on page 23.
3. Locate the front fan that you want to remove. See “Locating server components” on page 14.

Note: If two microprocessors are installed in your server, there are two front fans, one for microprocessor 1 and the other for microprocessor 2.

4. Disconnect the front fan cable from the front fan connector on the system board. See “Locating parts on the system board” on page 15.
5. Remove the hard disk drives. See “Removing a hot-swap hard disk drive” on page 38 or “Removing a non-hot-swap hard disk drive” on page 47.

6. The front fan is attached to the chassis by four rubber mounts **1**. Remove the front fan by cutting the rubber mounts and gently pulling the front fan out of the chassis.

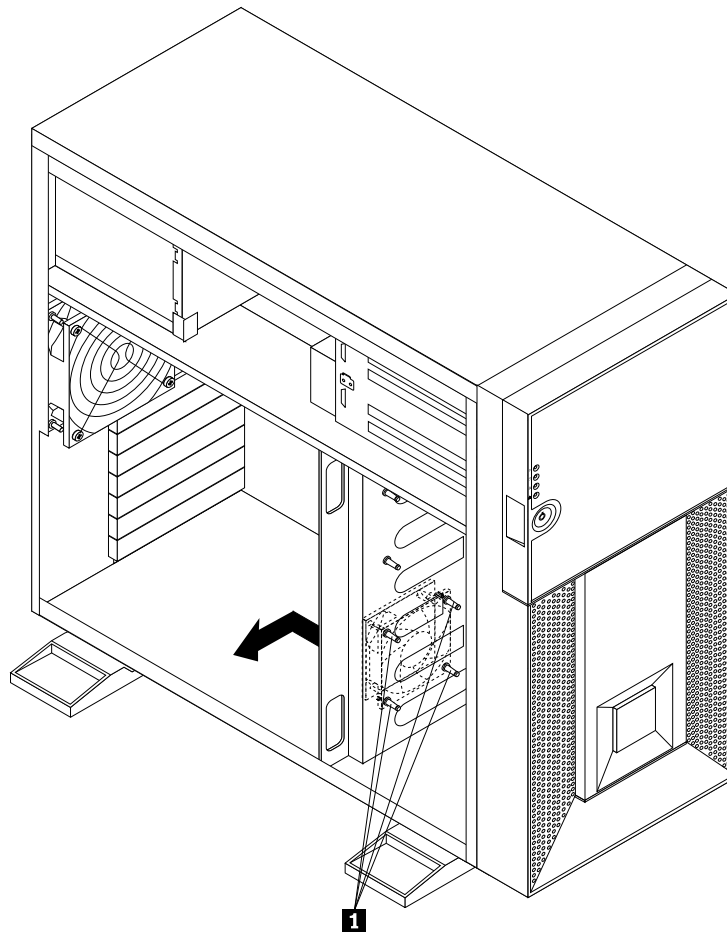

Figure 63. Removing the front fan

7. Reinstall all hard disk drives. See “Installing a hot-swap hard disk drive” on page 41 or “Installing a non-hot-swap hard disk drive” on page 49.
8. If you are instructed to return the removed front fan to the manufacturer, follow all packaging instructions and use any packaging materials that are supplied to you for shipping.

What to do next:

- To work with another piece of hardware, go to the appropriate section.
- To complete the removal procedure, go to “Completing the parts replacement” on page 90.

Installing a front fan

Attention:

Do not open your server or attempt any repair before reading and understanding the *Safety Information* and the *Warranty and Support Information* on the *ThinkServer Documentation DVD* that came with your product, and “Guidelines” on page 21. To obtain a copy of the publications, go to:
<http://www.lenovo.com/support>

This section provides instructions on how to install a front fan.

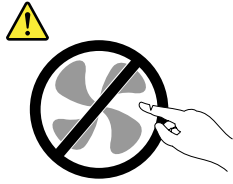

Hazardous moving parts. Keep fingers and other body parts away.

To install a front fan, do the following:

1. Remove all media from the drives and turn off all attached devices and the server. Then, disconnect all power cords from electrical outlets and disconnect all cables that are connected to the server.
2. Remove the server cover. See “Removing the server cover” on page 23.
3. Remove the hard disk drives. See “Removing a hot-swap hard disk drive” on page 38 or “Removing a non-hot-swap hard disk drive” on page 47.

4. Install the front fan by aligning the four rubber mounts with the corresponding holes in the chassis, and then push the rubber mounts through the holes.

Notes:

- a. The new front fan will have four new rubber mounts attached.
- b. If two microprocessors are installed in your server, you can install two front fans, one for microprocessor 1 and the other for microprocessor 2.
- c. You might also need to pull the rubber mounts through the holes from the other side to secure the front fan in place.

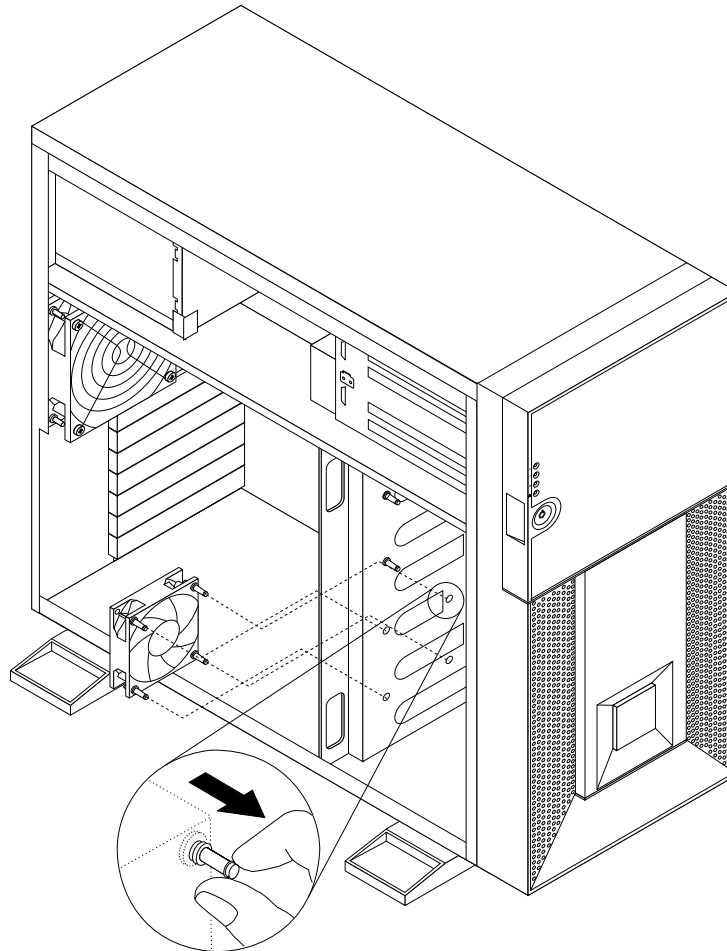

Figure 64. Installing the front fan

5. Connect the front fan cable to the corresponding front fan connector on the system board. See “Locating parts on the system board” on page 15.
6. Reinstall all hard disk drives. See “Installing a hot-swap hard disk drive” on page 41 or “Installing a non-hot-swap hard disk drive” on page 49.

What to do next:

- To work with another piece of hardware, go to the appropriate section.
- To complete the installation, go to “Completing the parts replacement” on page 90.

Removing or installing the rear fan

This section provides instructions on how to remove or install the rear fan.

Removing the rear fan

Attention:

Do not open your server or attempt any repair before reading and understanding the *Safety Information* and the *Warranty and Support Information* on the *ThinkServer Documentation DVD* that came with your product, and “Guidelines” on page 21. To obtain a copy of the publications, go to:
<http://www.lenovo.com/support>

This section provides instructions on how to remove the rear fan.



Hazardous moving parts. Keep fingers and other body parts away.

To remove the rear fan, do the following:

1. Remove all media from the drives and turn off all attached devices and the server. Then, disconnect all power cords from electrical outlets and disconnect all cables that are connected to the server.
2. Remove the server cover. See “Removing the server cover” on page 23.
3. Locate the rear fan. See “Locating server components” on page 14.
4. Disconnect the rear fan cable from the system fan 3 connector on the system board. See “Locating parts on the system board” on page 15.

5. The rear fan is attached to the chassis by four rubber mounts. Remove the rear fan by cutting the rubber mounts and gently pulling the rear fan out of the chassis.

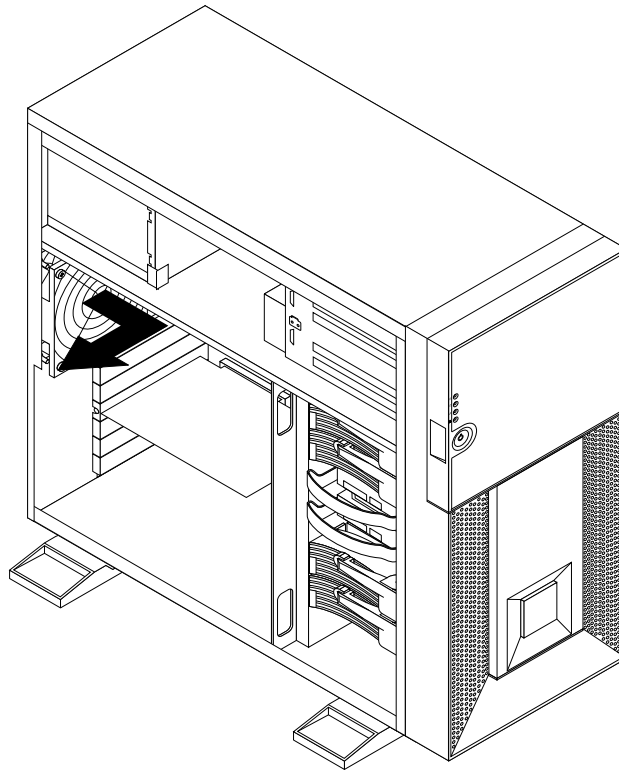

Figure 65. Removing the rear fan

6. If you are instructed to return the removed rear fan to the manufacturer, follow all packaging instructions and use any packaging materials that are supplied to you for shipping.

What to do next:

- To work with another piece of hardware, go to the appropriate section.
- To install the rear fan, see “Installing the rear fan” on page 83.

Installing the rear fan

Attention:

Do not open your server or attempt any repair before reading and understanding the *Safety Information* and the *Warranty and Support Information* on the *ThinkServer Documentation DVD* that came with your product, and “Guidelines” on page 21. To obtain a copy of the publications, go to:
<http://www.lenovo.com/support>

This section provides instructions on how to install the rear fan.

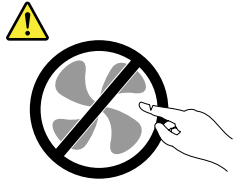

Hazardous moving parts. Keep fingers and other body parts away.

To install the rear fan, do the following:

1. Remove all media from the drives and turn off all attached devices and the server. Then, disconnect all power cords from electrical outlets and disconnect all cables that are connected to the server.
2. Remove the server cover. See “Removing the server cover” on page 23.

3. Place the rear fan on the chassis so that the four rubber mounts are aligned with the corresponding holes in the chassis. Then, push the rubber mounts through the holes.

Notes:

- a. The new rear fan will have four new rubber mounts attached.
- b. You might also need to pull the rubber mounts through the holes from the other side of the chassis to secure the rear fan in place.

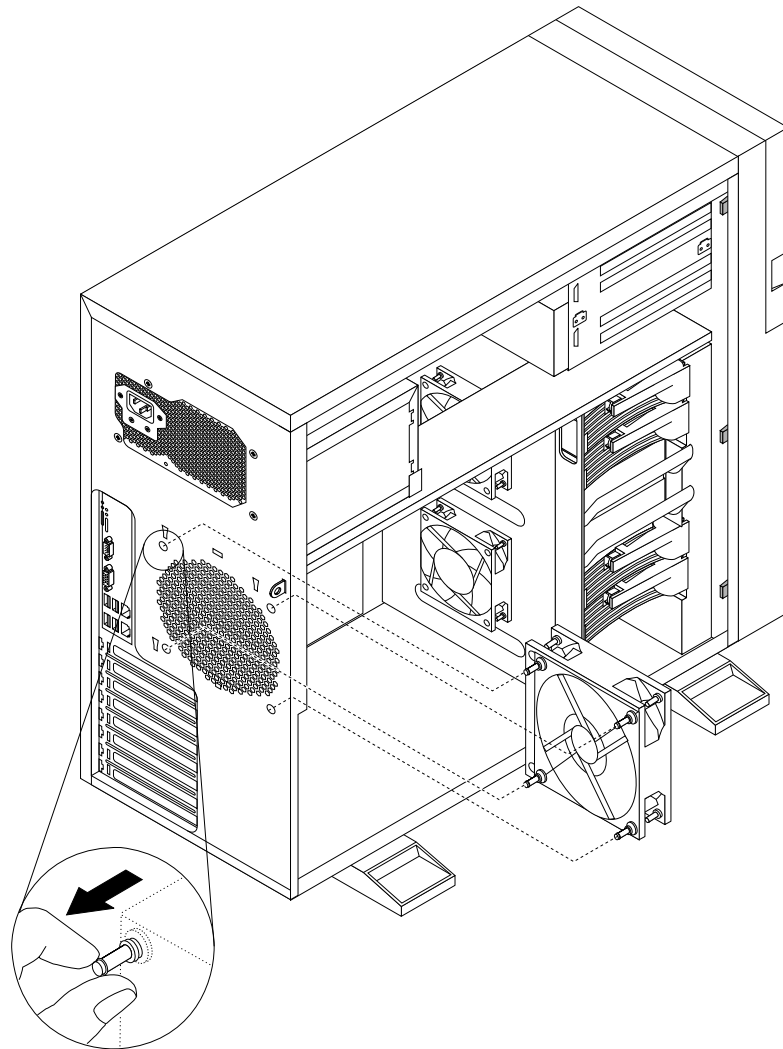

Figure 66. Installing the rear fan

4. Connect the rear fan cable to the system fan 3 connector on the system board. See “Locating parts on the system board” on page 15.

What to do next:

- To work with another piece of hardware, go to the appropriate section.
- To complete the installation, go to “Completing the parts replacement” on page 90.

Removing or installing the microprocessor

This section provides instructions on how to remove or install the microprocessor.

Removing the microprocessor

Attention:

Do not open your server or attempt any repair before reading and understanding the *Safety Information* and the *Warranty and Support Information* on the *ThinkServer Documentation DVD* that came with your product, and “Guidelines” on page 21. To obtain a copy of the publications, go to:
<http://www.lenovo.com/support>

This section provides instructions on how to remove the microprocessor.

CAUTION:



The heat sink and microprocessor might be very hot. Turn off the server and wait three to five minutes to let the server cool before removing the server cover.

To remove the microprocessor, do the following:

1. Remove all media from the drives and turn off all attached devices and the server. Then, disconnect all power cords from electrical outlets and disconnect all cables that are connected to the server.
2. Remove the server cover. See “Removing the server cover” on page 23.
3. Lay the server on its side for easier operation.
4. Remove the heat sink and fan assembly. See “Removing the heat sink and fan assembly” on page 71.
5. Lift the small handle and open the retainer to access the microprocessor. Then, carefully lift the microprocessor straight up and out of the socket, and place it on a static-protective surface.

Note: Touch only the edges of the microprocessor.

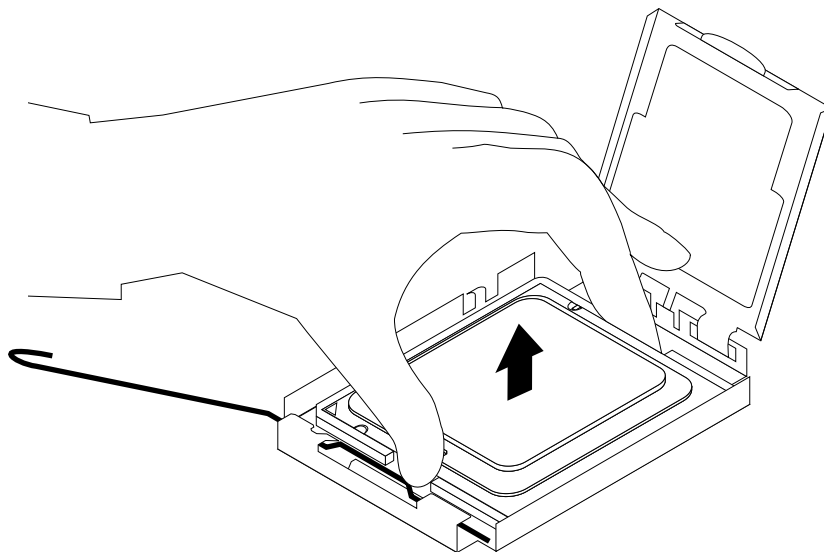

Figure 67. Removing the microprocessor

6. If you are instructed to return the microprocessor to the manufacturer, follow all packaging instructions and use any packaging materials that are supplied to you for shipping.

What to do next:

- To work with another piece of hardware, go to the appropriate section.
- To complete the removal procedure, go to “Completing the parts replacement” on page 90.

Installing the microprocessor

Attention:

Do not open your server or attempt any repair before reading and understanding the *Safety Information* and the *Warranty and Support Information* on the *ThinkServer Documentation DVD* that came with your product, and “Guidelines” on page 21. To obtain a copy of the publications, go to:
<http://www.lenovo.com/support>

This section provides instructions on how to install the microprocessor.

CAUTION:



The heat sink and microprocessor might be very hot. Turn off the server and wait three to five minutes to let the server cool before removing the server cover.

For optimal performance, follow these microprocessor installation rules:

1. When two microprocessors are installed, both must have the same core voltage and core speed.
2. When only one microprocessor is installed, it must be in the microprocessor 1 socket. The other socket must be empty.
3. Always install the microprocessor first into the microprocessor 1 socket, and then install another microprocessor into the microprocessor 2 socket if you want to install two microprocessors.

To install the microprocessor, do the following:

1. Remove all media from the drives and turn off all attached devices and the server. Then, disconnect all power cords from electrical outlets and disconnect all cables that are connected to the server.
2. Remove the server cover. See “Removing the server cover” on page 23.
3. Lay the server on its side for easier operation.
4. Remove the heat sink and fan assembly if necessary. See “Removing the heat sink and fan assembly” on page 71.
5. Press down and gently push the small handle a little bit outward on the microprocessor socket to lift the handle to the open position.

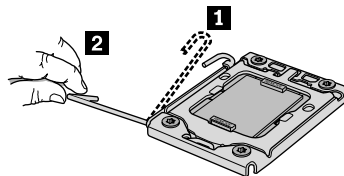

Figure 68. Lifting the handle

6. Slightly press the retainer of the microprocessor socket to open it.

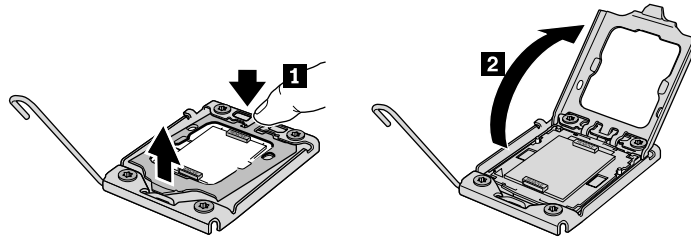

Figure 69. Opening the retainer

7. Remove the protective cover from the microprocessor socket. To avoid damaging the pins in the microprocessor socket, do not touch the pins while removing the cover.

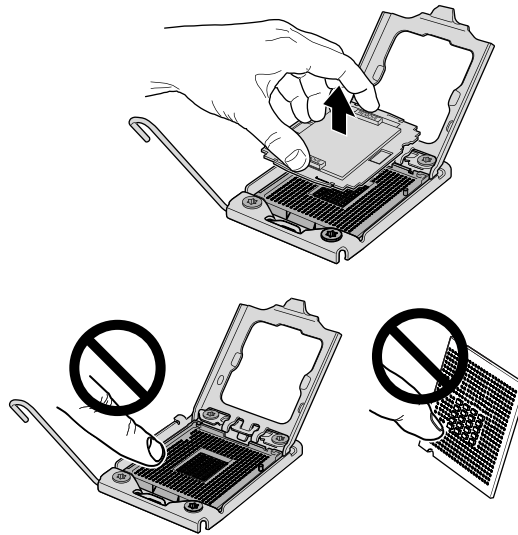

Figure 70. Removing the microprocessor socket cover

8. Remove the new microprocessor from the protective cover that protects the gold contacts on the bottom of the new microprocessor.



9. Hold the new microprocessor by the edges and align the notches **1** on it with the tabs **2** in the microprocessor socket. Then, install the microprocessor into the socket.

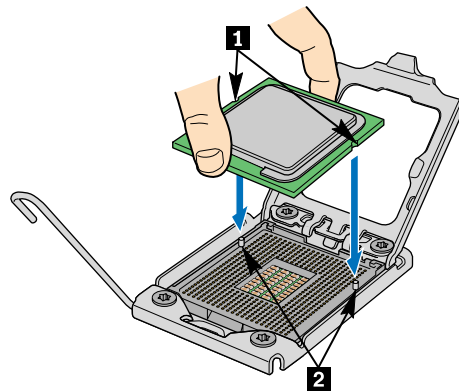

Figure 71. Installing the microprocessor

What to do next:

- To work with another piece of hardware, go to the appropriate section.
- To complete the installation, go to “Completing the parts replacement” on page 90.

Replacing the system board battery

Attention:

Do not open your server or attempt any repair before reading and understanding the *Safety Information* and the *Warranty and Support Information* on the *ThinkServer Documentation DVD* that came with your product, and “Guidelines” on page 21. To obtain a copy of the publications, go to:
<http://www.lenovo.com/support>

This section provides instructions on how to replace the system board battery.

Your server has a special type of memory that maintains the date, time, and configuration information for built-in features. The system board battery keeps this information active when you turn off the server.

The system board battery normally requires no charging or maintenance throughout its life; however, no battery lasts forever. If the system board battery fails, the date, time, and configuration information, including passwords, are lost. An error message is displayed when you turn on the server.

Be sure to consider the following information when you replace the battery in the server:

- You must replace the battery with a lithium battery of the same type from the same manufacturer.
- To avoid possible danger, be sure to read and understand the following safety statement.
- After you replace the system board battery, you must reset passwords, system date and time, and reconfigure the server.

Statement 2



CAUTION:

When replacing the lithium battery, use only Part Number 33F8354 or an equivalent type battery

recommended by the manufacturer. If your system has a module containing a lithium battery, replace it only with the same module type made by the same manufacturer. The battery contains lithium and can explode if not properly used, handled, or disposed of. **Do not:**

- Throw or immerse into water
- Heat to more than 100° C (212° F)
- Repair or disassemble

To replace the system board battery, do the following:

1. Remove all media from the drives and turn off all attached devices and the server. Then, disconnect all power cords from electrical outlets and disconnect all cables that are connected to the server.
2. Remove the server cover. See “Removing the server cover” on page 23.
3. Lay the server on its side for easier operation.
4. Locate the system board battery. See “Locating parts on the system board” on page 15.
5. Note the orientation of the system board battery and remove it from the socket.

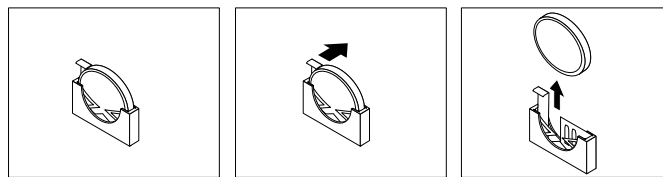

Figure 72. Removing the system board battery

6. Follow any special handling and installation instructions that came with the new system board battery and install the new system board battery into its socket. Make sure that the battery clip securely holds the battery.

Note: Note the orientation of the system board battery when you install it into the socket.

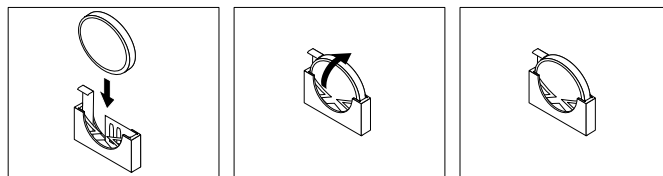

Figure 73. Installing the system board battery

7. Dispose of the failing battery as required by local ordinances or regulations.

What to do next:

- To work with another piece of hardware, go to the appropriate section.
- To complete the installation, go to “Completing the parts replacement” on page 90. After you replace the system board battery, you must reset passwords, system date and time, and reconfigure the server. See Chapter 6 “Configuring the server” on page 95.

Completing the parts replacement

This section provides instructions to help you complete the parts replacement and turn on your server.

To complete the parts replacement, you must reinstall the server cover, reconnect all the cables and, for some devices, run the Setup Utility program to do further setup.

Installing the server cover

This section provides instructions on how to install the server cover.

Attention: For proper cooling and airflow, install the server cover before turning on the server. Operating the server for extended periods of time (more than 30 minutes) with the cover removed might damage server components.

To install the server cover, do the following:

1. Make sure that all cables, cards, and other components are installed and seated correctly and that you have not left loose tools or parts inside the server. Also, make sure that all internal cables are correctly routed.
2. Position the server cover on the chassis so that the rail guides on the bottom of the server cover engage the rails. Then, slide the server cover to the front of the server until it snaps into position and is closed. Then, tighten the two thumbscrews to secure the server cover.

Note: Although the server cover is secured by two thumbscrews, for safety consideration, be sure to use a tool, for example a screw driver, to tighten the thumbscrews and always make sure that the thumbscrews are securely installed. Also, do not over-tighten the thumbscrews.

3. Lock the server cover if you have a server cover lock, such as a padlock.

Connecting the cables

Attention: To prevent damage to equipment, connect the power cords last.

If the server cables and connector panel have color-coded connections, match the color of the cable end with the color of the connector. For example, match a blue cable end with a blue panel connector, a red cable end with a red connector, and so on. See “Rear view” on page 12 for an illustration of the I/O connectors on the rear of the server.

Turning on the server

When the server is connected to an ac power source but is not turned on, the operating system does not run, and all core logic except for the service processor (the integrated management module) is shut down; however, the server can respond to requests to the service processor, such as a remote request to turn on the server.

After the server is connected to an ac power source, you can turn on the server by pressing the power button.

Updating the server configuration

When you turn on the server for the first time after you add or remove a device, you might receive a message to notify you that the configuration has been changed. The Setup Utility program starts automatically so that you can save the new configuration settings. For more information, see Chapter 6 “Configuring the server” on page 95.

Some optional devices have device drivers that you must install. For information about installing device drivers, see the documentation that comes with each device.

The server comes with at least one microprocessor. If more than one microprocessor is installed, the server can operate as a symmetric multiprocessing (SMP) server. You might have to upgrade the operating system to support SMP. For more information, see the operating-system documentation.

If the server has an optional RAID controller and you have installed or removed a hard disk drive, see the documentation that comes with the RAID controller for information about reconfiguring the disk arrays.

Turning off the server

When you turn off the server and leave it connected to an ac power source, the server can respond to requests to the service processor, such as a remote request to turn on the server. To remove all power from the server, you must disconnect the power cord from the server.

Some operating systems require an orderly shutdown before you turn off the server. See your operating-system documentation for information about shutting down the operating system.

Statement 5



CAUTION:

The power control button on the device and the power switch on the power supply do not turn off the electrical current supplied to the device. The device also might have more than one power cord. To remove all electrical current from the device, ensure that all power cords are disconnected from the power source.

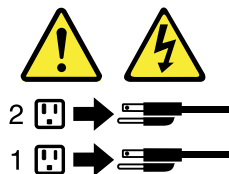

The server can be turned off in any of the following ways:

- You can turn off the server from the operating system, if your operating system supports this feature. After an orderly shutdown of the operating system, the server will turn off automatically.
- You can press the power button to start an orderly shutdown of the operating system and turn off the server, if your operating system supports this feature.
- If the operating system stops functioning, you can press and hold the power button for more than four seconds to turn off the server.
- The server can be turned off by the Shutdown on LAN feature.
- The integrated management module (IMM) can turn off the server as an automatic response to a critical system failure.

Connecting external devices

If you install a supported optional adapter, you can attach external devices to the server.

To attach an external device, do the following:

Note: If you are attaching an external device, see the documentation that comes with the device for information about cabling.

1. Read and understand the *Safety Information* on the *ThinkServer Documentation DVD* that comes with your product, and “Guidelines” on page 21. To obtain a copy of the publications, go to:
<http://www.lenovo.com/support>
2. Turn off the server and all attached devices.

3. Follow the instructions that come with the device to prepare it for installation and to connect it to the server.

Chapter 6. Configuring the server

The following configuration programs come with the server:

- **Setup Utility program**
The Setup Utility program is part of the server firmware. You can use the Setup Utility program to view your server configuration, change the startup device sequence, set the date and time, and set passwords. For information about using this program, see “Using the Setup Utility program” on page 95.
- **Ethernet controller configuration**
For information about configuring the Ethernet controller, see “Configuring the Gigabit Ethernet controller” on page 109.
- **INTEL ESRT2 SATA software RAID Configuration Utility program**
Use the INTEL ESRT2 SATA software RAID Configuration Utility program to configure the onboard SATA controller with software RAID capabilities and the devices that are attached to it. For information about using this program, see “Configuring the onboard SATA software RAID” on page 106.
- **ThinkServer 9240-8i SAS RAID controller Configuration Utility program**
Use the Configuration Utility program for 9240-8i SAS RAID controller to configure the 9240-8i SAS RAID controller with RAID capabilities and the devices that are attached to it. For information about using this program, see the *MegaRAID SAS Software User Guide* on the *ThinkServer Documentation DVD* that came with your server.

The following table lists the different server configurations and the applications that are available for configuring and managing RAID arrays.

Table 9. Server configurations and applications for configuring and managing RAID arrays

Server configuration	RAID array configuration (before operating system is installed)	RAID array management (after operating system is installed)
INTEL ESRT2 SATA software RAID	INTEL ESRT2 Configuration Utility program (press Ctrl+E to start)	INTEL RAID Storage Manager (WebConsole)
ThinkServer 9240-8i RAID 0/1 Adapter	MegaRAID WebBIOS Configuration Utility (press Ctrl+H to start)	MegaRAID Storage Manager (MSM)

Using the Setup Utility program

Use the Setup Utility program to perform the following tasks:

- View configuration information
- View and change assignments for devices and I/O ports
- Set the date and time
- Set the startup characteristics of the server and the order of startup devices
- Set and change settings for advanced hardware features
- View, set, and change settings for power-management features
- View and clear error logs
- Resolve configuration conflicts

Starting the Setup Utility program

To start the Setup Utility program, do the following:

1. After the server is connected to a working electrical outlet, the power button becomes active. Turn on the server by pressing the power button and the POST runs automatically. You will then see the logo screen. The POST is a set of tests and procedures that are performed each time you turn on your server.
2. Press F2 as soon as you see the logo screen. The Setup Utility program opens. If you have set an administrator password, you must type the administrator password to access the full Setup Utility program menu. If you do not type the correct administrator password, a limited Setup Utility program menu is available.

Note: You can also press Esc as soon as you see the logo screen to review the POST process and information.

3. The Setup Utility program menu lists various items about the system configuration settings. Select the settings to view or change.

When working with the Setup Utility program, you must use the keyboard. The keys used to perform various tasks are displayed at the bottom of each screen.

Notes:

1. Use the default setting for any item you are not familiar with. Do not change the value of unfamiliar items or items that are not mentioned in this manual to avoid any unexpected problems. If you cannot turn on the server because of incorrect BIOS settings, refer to “Jumper block settings” on page 17 and use the jumpers to clear CMOS and recover to the factory default settings.
2. If you have changed any hardware (except the hard disk drives) in the server, you must reflash the BIOS, the BMC firmware, and the FRU/SDR.

Introduction of the BIOS items

The following tables list all the main menus and items in the Setup Utility program. Some items might vary because of the BIOS updates.

Notes:

1. Use the default setting for any item you are not familiar with. Do not change the value of unfamiliar items or items that are not mentioned in this manual to avoid any unexpected problems. If you cannot turn on the server because of incorrect BIOS settings, refer to “Jumper block settings” on page 17 and use the jumpers to clear CMOS and recover to the factory default settings.
2. After updating the BIOS, all the BIOS settings become the default settings of the updated BIOS version. You need to check and reconfigure the BIOS settings for your specific needs.

Table 10. The Setup Utility program main menu

Item	Description
Main	Set the basic BIOS parameters. See Table 11 “Items under the Main menu” on page 97.
Advanced	Set the advanced BIOS parameters. See Table 12 “Items under the Advanced menu” on page 97.
Security	Set the security parameters. See Table 21 “Items under the Security menu” on page 100.
Server Management	Set the server system management parameters. See Table 22 “Items under the Server Management menu” on page 100.
Boot Options	Set the boot parameters. See Table 23 “Items under the Boot Options menu” on page 101.

Table 10. The Setup Utility program main menu (continued)

Item	Description
Boot Manager	From the current detected boot devices, select the first boot device for system initialization.
Error Manager	View the system error information.
Exit	Exit the Setup Utility program.

Table 11. Items under the **Main** menu

Item	Option	Description
Quiet Boot	Disabled / [Enabled]	Enable or disable the feature to show OEM Logo during the POST.
Post Error Pause	[Disabled] / Enabled	Pause or not when boot error occurs.
System Time	HH:MM:SS	Set system time.
System Date	MM/DD/YYYY	Set system date.
Note: The settings in [] are the default settings in the Setup Utility program.		

Table 12. Items under the **Advanced** menu

Item	Description
Processor Configuration	Enter the submenu to see all the options. See Table 13 “Submenus under the Processor Configuration ” on page 98.
Memory Configuration	Enter the submenu to see all the options. See Table 14 “Submenus under the Memory Configuration ” on page 98.
Mass Storage Controller Configuration	Enter the submenu to see all the options. See Table 16 “Submenus under the Mass Storage Controller Configuration ” on page 99.
Serial Port Configuration	Enter the submenu to see all the options. See Table 17 “Submenus under the Serial Port Configuration ” on page 99.
USB Configuration	Enter the submenu to see all the options. See Table 18 “Submenus under the USB Configuration ” on page 99.
PCI Configuration	Enter the submenu to see all the options. See Table 19 “Submenus under the PCI Configuration ” on page 100.
System Acoustic and Performance Configuration	Enter the submenu to see all the options. See Table 20 “Submenus under the System Acoustic and Performance Configuration ” on page 100.
Note: Do not change any unfamiliar item value under the Advanced menu.	

Table 13. Submenus under the **Processor Configuration**

Item	Option	Description
Enhanced Intel SpeedStep™ Tech	Disabled / [Enabled]	Enable or disable the SpeedStep technology.
Intel Hyper-Threading Tech	Disabled / [Enabled]	Enable or disable the hyper-thread technology. (Whether your server supports this feature or not is depending on the type of the installed microprocessor.)
Core Multi-Processing	Disabled / [Enabled]	Enable or disable the multi-core processing function.
Execute Disable Bit	Disabled / [Enabled]	Enabling the Execute-Disable Bit Capability can prevent the executive code of some malicious software from using the data page.
Intel® Virtualization Technology	[Disabled] / Enabled	Enable or disable the Intel Virtualization Tech. This technology can provide additional capacity for hardware computing. If you set this feature to Enabled , you have to turn off the server and disconnect the power cord from electrical outlet, and then reconnect the power cord and turn on the server to make this feature take effect.
Intel VT for Directed I/O	[Disabled] / Enabled	Enable or disable the Intel Virtualization Tech for I/O devices.
Hardware Prefetcher	Disabled / [Enabled]	Enable or disable the prefetch function of the microprocessor. This setting might impact system performance.
Adjacent Cache Line Prefetch	Disabled / [Enabled]	Enable or disable the adjacent cache line prefetch. This setting might impact system performance.
Direct Cache Access (DCA)	Disabled / [Enabled]	Enable or disable the direct distribution of I/O data to the cache of microprocessor to improve the I/O capability.
Notes:		
1. The settings in [] are the default settings in the Setup Utility program.		
2. The above options might vary depending on the type of the installed microprocessor.		

Table 14. Submenus under the **Memory Configuration**

Item	Description
Total Memory	View the total memory capacity.
Effective Memory	View the effective memory capacity.
Current Configuration	Current configuration is the most effective mode.
Current Memory Speed	View the memory speed information.
Memory RAS and Performance Configuration	Enter the submenu to see all the options. See Table 15 “Submenus under the Memory RAS and Performance Configuration ” on page 99.

Table 15. Submenus under the **Memory RAS and Performance Configuration**

Item	Option	Description
Select Memory RAS Configuration		Select the RAS configuration for installed memory modules.
NUMA Optimized	Disabled / [Enabled]	Whether the BIOS contains the ACPI configuration form required by NUMA OS.
Note: The settings in [] are the default settings in the Setup Utility program.		

Table 16. Submenus under the **Mass Storage Controller Configuration**

Item	Option	Description
Onboard SATA Controller	Disabled / [Enabled]	Enable or disable the integrated SATA controller.
SATA Mode	[Enhanced] / Compatibility / AHCI / SW RAID	To select the SATA mode.
Note: The settings in [] are the default settings in the Setup Utility program.		

Table 17. Submenus under the **Serial Port Configuration**

Item	Option	Description
Serial A Enable	Disabled / [Enabled]	Enable or disable the serial port 1 I/O.
Address	[3F8] / 2F8 / 3E8 / 2E8	Select the serial port 1 I/O address.
IRQ	3 / [4]	Select the serial port 1 I/O interruption.
Serial B Enable	Disabled / [Enabled]	Enable or disable the serial port 2 I/O.
Address	3F8 / [2F8] / 3E8 / 2E8	Select the serial port 2 I/O address.
IRQ	[3] / 4	Select the serial port 2 I/O interruption.
Note: The settings in [] are the default settings in the Setup Utility program.		

Table 18. Submenus under the **USB Configuration**

Item	Option	Description
USB Controller	[Enabled] / Disabled	Enable or disable the USB function.
Legacy USB Support	Disabled / [Enabled] / Auto	Enable or disable the support on legacy USB devices.
Port 60/64 Emulation	[Enabled] / Disabled	Enable or disable the I/O port. This function is for the operating system that does not support on legacy USB devices.
Make USB Devices Non-Bootable	[Disabled] / Enabled	Set the USB device as non-bootable device.
Device Reset Timeout	10 sec / [20 sec] / 30 sec / 40 sec	Set the device reset timeout.
USB 2.0 Controller	[Enabled] / Disabled	Enable or disable the USB 2.0 support.
Note: The settings in [] are the default settings in the Setup Utility program.		

Table 19. Submenus under the **PCI Configuration**

Item	Option
Maximize Memory below 4 GB	[Disabled] / Enabled
Memory Mapped I/O above 4 GB	[Disabled] / Enabled
Onboard Video	[Disabled] / Enabled
Dual Monitor Video	[Disabled] / Enabled (If enable this option, the system can support the add-in graphics card.)
Onboard NIC1 ROM	[Enabled] / Disabled
Onboard NIC2 ROM	[Enabled] / Disabled
Onboard iSCSI ROM	[Disabled] / Enabled
Note: The settings in [] are the default settings in the Setup Utility program.	

Table 20. Submenus under the **System Acoustic and Performance Configuration**

Item	Option	Description
Set Throttling Mode	[Auto] / [OLTT] / CLTT	Set the throttling mode.
Altitude	300 m or less / [301 m-900 m] / 901 m-1500 m / Higher than 1500 m	Set the altitude.
Set Fan Profile	[Performance] / Acoustic	Select the priority for the system fan control method.
Note: The settings in [] are the default settings in the Setup Utility program.		

Table 21. Items under the **Security** menu

Item	Option	Description
Set Administrator Password		Set or change the administrator password. The password can be any combination of up to 7 (1 to 7) alphabetic and numeric characters.
Set User Password		Set or change the user password. The password can be any combination of up to 7 (1 to 7) alphabetic and numeric characters.
Front Panel Lockout	[Disabled] / Enabled	If this option is set to Enabled , the power button and reset button on the front panel will be locked.
Note: The settings in [] are the default settings in the Setup Utility program.		

Table 22. Items under the **Server Management** menu

Item	Option	Description
Assert NMI on SERR	[Enabled] / Disabled	
Assert NMI on PERR	[Enabled] / Disabled	
Resume on AC Power Loss	[Stays Off] / Last state / Reset	If the power is interrupted when the server is on, after the power resumes, the server will restart automatically, or keep the off state, or resume to the last state.
Clear System Event Log	[Disabled] / Enabled	

Table 22. Items under the **Server Management** menu (continued)

Item	Option	Description
FRB-2 Enable	[Enabled] / Disabled	
OS Boot Watchdog Timer	[Disabled] / Enabled	
OS Boot Watchdog Timer Policy	[Power Off]	Default. Cannot be modified.
OS Boot Watchdog Timer Timeout	[10 minutes]	Default. Cannot be modified.
Plug & Play BMC Detection	[Disabled] / Enabled	
ACPI 1.0 Support	[Disabled] / Enabled	
Console Redirection	[Disabled] / Serial Port A / Serial Port B	
System Information		View the system information.
BMC LAN Configuration	Baseboard LAN configuration	Use this option to configure the Baseboard LAN.
	Intel (R) RMM3 LAN configuration	Use this option to configure the RMM3 LAN.
	User configuration	Use this option to configure the user ID and password.
Note: The settings in [] are the default settings in the Setup Utility program.		

Table 23. Items under the **Boot Options** menu

Item	Option
System Boot Timeout	[0]
Boot Option #1	Use this option to set the first boot device.
Boot Option #2	Use this option to set the second boot device.
Boot Option #3	Use this option to set the third boot device.
Boot Option #4	Use this option to set the fourth boot device.
Network Device Order	Use this option to set the network device boot sequence.
Delete Boot Option	Delete boot options.
EFI Optimized Boot	[Disabled] / Enabled
Boot Option Retry	[Disabled] / Enabled
Note: The settings in [] are the default settings in the Setup Utility program.	

Exiting the Setup Utility program

After you finish viewing or changing settings, press Esc to return to the Setup Utility program main menu. You might have to press Esc several times. Then, you can do one of the following:

- If you want to save the new settings and exit the Setup Utility program, press F10. Otherwise, your changes will not be saved.
- If you do not want to save the new settings, select **Exit → Discard Changes and Exit**.
- If you want to return to the default settings, press F9 or select **Exit → Load Default Values**.

Using passwords

By using the Setup Utility program, you can set a password to prevent unauthorized access to your server and data. The following options are available to help you set an administrator password or a user password:

- **Set Administrator Password**
- **Set User Password**

You do not have to set a password to use your server. However, using a password improves computing security. If you decide to set a password, read the following sections.

Password considerations

A password can be any combination of up to 7 (1 to 7) alphabetic and numeric characters. For security reasons, it is recommended to use a strong password that cannot be easily compromised. To set a strong password, use the following guidelines:

Note: The Setup Utility program passwords are not case sensitive.

- Contain at least one alphabetic character and one numeric character
- Not be your name or your user name
- Not be a common word or a common name
- Be significantly different from your previous passwords

Setting, changing, or deleting a password

This section provides instructions on how to set, change, or delete a password.

To set, change, or delete a password, do the following:

1. Start the Setup Utility program. See “Starting the Setup Utility program” on page 95.
2. From the Setup Utility program main menu, select **Security → Set Administrator Password** or **Set User Password**. For information about the administrator password and user password, see Table 21 “Items under the **Security** menu” on page 100.
3. Follow the instructions on the screen to set, change, or delete a password.

Note: A password can be any combination of up to 7 (1 to 7) alphabetic and numeric characters. For more information, see “Password considerations” on page 102.

RAID controllers

The following table lists the various utilities available to configure RAID controllers before an operating system is installed.

Table 24. RAID utilities

RAID configuration utility	Description	Location	Where to find more information
EasyStartup RAID configuration utility	<ul style="list-style-type: none"> • For use with all factory-supported RAID controllers • Automatically detects hardware and lists all supported RAID configurations • Configures one disk array per controller using all drives currently attached to the controller • Created a RAID response file that can be used to configure RAID controllers on similarly configured Lenovo servers. 	EasyStartup DVD	“Using the ThinkServer EasyStartup program” on page 103
INTEL ESRT2 SATA software RAID Configuration Utility program	INTEL ESRT2 SATA software RAID	Press Ctrl+E to start	“Configuring the onboard SATA software RAID” on page 106
ThinkServer MegaRAID WebBIOS Configuration Utility	ThinkServer 9240-8i RAID 0/1 Adapter	Press Ctrl+H to start	Refer to the <i>MegaRAID SAS Software User Guide</i> on the <i>ThinkServer Documentation DVD</i> that came with your server or download the publication from the Lenovo Support Web site at http://www.lenovo.com/support . And you can find and install the MegaCLI program and the MegaRAID Storage Manager program in the <i>ThinkServer EasyStartup DVD</i> that came with your server. Insert the DVD into the optical drive and the files are in the \Tools And Utilities directory.

Using the ThinkServer EasyStartup program

The *ThinkServer EasyStartup* DVD simplifies the process of configuring your RAID controllers and installing an operating system. The program works in conjunction with your Windows or Linux operating-system installation disc to automate the process of installing the operating systems and associated device drivers.

If you did not receive an *ThinkServer EasyStartup* DVD with your server, you can download an image from the Lenovo Support Web site at <http://www.lenovo.com/support>.

The EasyStartup program has the following features:

- Self-booting DVD

- Easy-to-use, language-selectable interface
- Integrated help system
- Automatic hardware detection
- RAID configuration utility
- Device drivers provided based on the server model and detected devices
- Selectable partition size and file system
- Support for multiple operating systems
- Installs the operating system and device drivers in an unattended mode to save time
- Creates a reusable response file that can be used with similarly configured Lenovo servers to make future installations even faster.

Before you use the EasyStartup DVD

Functionality and supported operating systems can vary with different versions of the EasyStartup program. To learn more about the version you have, do the following:

1. Insert the *ThinkServer EasyStartup* DVD and restart the server.
2. Advance to the Home screen.
3. Click **Compatibility notes**. The compatibility notes feature provides detailed information about the RAID controllers, operating systems, and server configurations supported by that version of the EasyStartup program.
4. Click **User Guide**. The User Guide provides an overview of the various functions provided by that version of the EasyStartup program.

Before using the EasyStartup program to install an operating system, make sure any external storage devices and fiber channels are configured correctly.

Setup and configuration

When you start the *ThinkServer EasyStartup* DVD, you will be prompted for the following:

- Select the language in which you want to view the program.
- Select the language of the keyboard you will be using with the program.

Note: The following language keyboards are supported: English, French, German, Spanish, Japanese, Turkish, Italian, and Dutch. Your *ThinkServer EasyStartup* DVD might be English only. In this case, the keyboard layout should be English.

You will then see one or more reminders about configuring storage devices, and then you will be presented with the Lenovo License Agreement. Read the license agreement carefully. You must agree with terms in order to continue.

After agreeing to the license agreement, you will be given the following choices:

- Continue to the main program interface
- Use a shortcut to install an operating system based a response file that you previously created using the EasyStartup program
- Use a shortcut to configure RAID controllers based on a RAID response file that you previously created using the EasyStartup program

If you continue to the main program interface, you will have the following selectable options:

- **Compatibility notes:** This selection provides information about the RAID controllers, operating systems, and server configurations supported by that version of the EasyStartup program.
- **User Guide:** This selection provides information about the features provided by that version of the EasyStartup program.
- **Hardware list:** This selection displays a list of hardware devices detected by the EasyStartup program.
- **Configure RAID:** This selection enables you to view the current RAID configuration for each installed RAID controller and make changes if needed.
- **Install operating system:** This selection displays a series of choices and prompts to collect information required for installation, prepares the hard disk for installation, and then initiates the installation process using the user-provided operating-system installation CD or DVD.
- **About:** This selection displays version information and legal notices.

Configuring RAID

The RAID configuration feature that is part of the EasyStartup program enables you to view and change RAID settings for supported RAID controllers. Through this feature, you have the ability to configure each installed controller. The program automatically detects the number of discs currently attached to the controller, determines the possible RAID configurations that can be configured, and prompts you through the steps to configure one or more disk arrays with or without hot-spare hard disk drives. As you configure each controller you will be given the option to save the RAID configuration settings to a RAID response file, which you can use on other similarly configured Lenovo servers. This method satisfies most users' needs.

Typical operating system installation

When you select **Install operating system**, you will be prompted for information required for the installation. The prompts vary depending on the operating system selected. This section describes the tasks associated with a typical Windows operating system installation. Each task must be completed in order before moving to the next task.

Note: Ensure that your RAID controller is correctly configured before you select an operating system to install.

- **Select operating system:** This task enables you to select the operating system that you will be installing.
- **Select disk:** This task enables you to select the disk where you want to install the operating system.

Note: The disk that you select must be set as the boot disk in the Setup Utility program.

- **Partitions options:** This task enables you to choose whether you want to repartition the selected drive or use an existing partition.
- **Partition settings:** This task enables you to choose the file system type and define the partition size.
- **Installation settings:** This task prompts you for user and system settings, the operating system product key, and the administrator password.
- **Network settings:** This task prompts you for domain and workgroup settings, Ethernet controller type, IP address settings, DNS settings, and WINS address settings.
- **Install applications:** This task enables you to run custom commands or scripts at the end of the installation process and install the ThinkServer EasyManage program to help you manage your servers.
- **Install Windows components:** This task enables you to install optional Windows components such as IIS, ASP.NET, and SNMP.
- **Confirm settings:** This task enables you to review all of the information you provided.
- **Save response file:** This task gives you the option of saving the information on a diskette or USB device as a response file for future installations on similarly configured Lenovo servers.

- **Start installation:** This task starts the actual installation process. First, the disk is prepared using the disk and partition information you specified. Then you are prompted to insert the operating system disk, and the operating system is installed using the information that you specified.

Configuring the onboard SATA software RAID

This chapter provides instructions on how to configure the onboard SATA software RAID by using the INTEL ESRT2 Configuration Utility program.

RAID information

During system startup, the SATA RAID BIOS is initialized and the BIOS version of the RAID adapter, the current RAID status, and the configuration of the array will be displayed on the screen. The status of the array will be one of the following:

1. **Online**
This status indicates the normal operation of the RAID array.
2. **Degrade**
This status indicates that more than one hard disk drive is faulty or disconnected from mirror volume and you have to replace the faulty hard disk drives and recover the data through the **Rebuild** function.
3. **Offline**
This status indicates that the RAID array is failed and unable to be restored by rebuilding. You have to create the array again.

Starting the Intel Embedded Server RAID Technology II program

To start the Intel Embedded Server RAID Technology II program, do the following:

1. During the POST, when you see the message “Press <Ctrl> <E> to enter Embedded RAID II Configuration Utility”, press Ctrl+E to enter the main menu for the SATA RAID configuration program.
2. Follow the instructions on the screen to configure the SATA RAID. When working with this program, you must use the keyboard. The keys used to perform various tasks are displayed at the bottom of each screen.

The main menu of the SATA RAID configuration program includes the following items:

- The **Configure** item is for configuring the RAID volume, including creating a new volume, deleting a volume, adding a volume, and setting the RAID volume boot sequence.
- The **Initialize** item is for initializing the RAID volume.
- The **Objects** item is for selecting Adapter, Logical drive, or Physical Drive and doing related settings.
- The **Rebuild** item is for rebuilding the RAID volume.
- The **Check Consistency** item is for consistency check.

Creating a RAID volume

This section provides instructions on how to create a RAID volume by using the Intel Embedded Server RAID Technology II program.

There are three methods to create a RAID volume:

- **Easy Configuration:** Using all hard disk drives to create a RAID array. You can set the stripe size by using this method, however, you cannot select the capacity of the array.
- **New Configuration:** If you use this method to create a RAID array, the existing RAID array will be deleted. You can select both the stripe size and the array capacity for the new RAID array.

- View/Add Configuration: Viewing the current RAID array, adding a new RAID array, or reconfiguring the current RAID array.

Note: If you use the Easy Configuration to create a new RAID volume, the current RAID volume will be deleted. If you want to create a new RAID volume without deleting the current data, use the View/Add Configuration.

To create a RAID volume by using the Easy Configuration option, do the following:

1. Select **Management → Configure** from the main menu and press Enter. The **Configuration Menu** opens.
2. Select **Easy Configuration**.
3. Press the space key to select physical drives. The free physical drives will be shown as **READY**. After you select one, it will be shown as **ONLIN A[array number]-[hard disk drive number]**. For example, **ONLIN A1-3** denotes the number 3 hard disk drive in array 1.
4. After you finish selecting the physical drives, press Enter or F10. The array selection window opens. Press the space key to select the array.
5. Press F10, the **Virtual Drive(s) Configured** window opens. The following table is an example about the information on this window.

Virtual Drive(s) Configured					
VD	RAID	Size	#Stripes	StripSz	Status
0	0	73664 MB	1	64 KB	ONLINE

6. Select **RAID** on the **Virtual Drive(s) Configured** window and press Enter. The RAID array selection menu opens.
7. Select the RAID array you want to create and press Enter.
8. Set the stripe size for the new array. Then, select **ACCEPT** and press Enter.

Note: If you are creating a RAID volume by using the New Configuration option, you can also set the volume capacity.

9. Follow the instructions on the screen to finish all settings. Then, press Esc to exit the program. When prompted, select **Yes** and press Enter to save the configuration.
10. Press Esc to go back to the main menu. Then, initialize the RAID volume you have created. See “Initializing the RAID volume” on page 107.

Initializing the RAID volume

This section provides instructions on how to initialize the RAID volume you have created. After you create a new RAID volume, it is recommended that you initialize the created RAID volume. However, initializing the RAID volume will delete the data on the selected RAID volume.

To initialize the RAID volume you have created, do the following:

1. Do one of the following:
 - Select **Management → Initialize** from the main menu and then use the space key to select the desired RAID volume. Press F10 to start initializing the RAID volume.
 - Select **Objects → Logical Drive** from the main menu and then select the desired RAID volume. Press F10 to start initializing the RAID volume.
2. When prompted, select **Yes** and press Enter to continue the initialization.
3. When you finish initializing the RAID volume, press Esc to go back to the main menu.

During the process of the initialization, you can press Esc for the following options:

- Stop - stop the current process
- Continue - continue the current process
- Abort - exit the current process

Deleting the RAID volume

This section provides instructions on how to delete the RAID volume.

To delete the RAID volume, do the following:

1. Select **Management** → **Configure** from the main menu and press Enter. The **Configuration Menu** opens.
2. Select **Clear Configuration**.
3. Follow the instructions on the screen to select the RAID volume.
4. Select **Yes** and press Enter to delete the RAID volume.

Rebuilding the RAID volume

When there is a failing hard disk drive in the volume, you need to replace the hard disk drive. You can restore the RAID volume through the rebuilding function.

To rebuild the RAID volume, do the following:

1. Do one of the following:
 - Select **Management** → **Rebuild** from the main menu. The hard disk drive selection window opens. The failing hard disk drive will be marked as **FAIL**.
 - Select **Objects** → **Physical Drive** from the main menu.
2. Use the space key to select the hard disk drive that needs to be rebuilt.
3. Press F10. When prompted, select **Yes** to start rebuilding. The hard disk drive status will be shown as **REBUILD**.
4. After finish rebuilding, press any key to continue other operations you want to do.

Checking the RAID 1 volume consistency

Checking the consistency of the RAID volume helps you find the problem about inconsistency volume data and then automatically restore this problem. This function only applies to RAID 1.

The controller can only report the inconsistency or report and fix the inconsistency. From the main menu, select **Objects** → **Adapter** → **Chkconstate** to set the controller.

To check the consistency of the RAID 1 volume, do the following:

1. Select **Management** → **Check Consistency** from the main menu and press Enter. The **Check Consistency** menu opens.
2. Use the space key to select the desired RAID volume.

Note: Only the RAID 1 volume can be selected. If you select other RAID volume, for example RAID 0, a message will be displayed, showing this volume cannot be selected.

3. Press F10. When prompted, select **Yes** to start checking the consistency.

Configuring the Gigabit Ethernet controller

The Ethernet controllers are integrated on the system board. They provides an interface for connecting to a 10 Mbps, 100 Mbps, or 1 Gbps network and provides full-duplex (FDX) capability, which enables simultaneous transmission and reception of data on the network. If the Ethernet ports in the server supports auto-negotiation, the controllers detect the data-transfer rate (10BASE-T, 100BASE-TX, or 1000BASE-T) and duplex mode (full-duplex or half-duplex) of the network and automatically operates at that rate and mode.

You do not have to set any jumpers or configure the controllers. However, you must install a device driver to enable the operating system to address the controllers.

Updating the firmware

The firmware in the server is periodically updated and is available for download on the Lenovo Support Web site. Go to <http://www.lenovo.com/support> to check for the latest level of firmware, such as the BIOS ROM file, BMC FW and RAID FW files.

When you replace a device in the server, you might have to either update the server with the latest version of the firmware that is stored in memory on the device or restore the pre-existing firmware from a diskette or CD image.

- The BIOS ROM file is stored in flash on the system board.
- The Ethernet firmware is stored in EEPROM on the Ethernet controller.
- The onboard SATA software RAID firmware is integrated into the BIOS ROM on the system board.
- The SAS RAID card firmware is stored in ROM on the SAS RAID card.

The Ethernet firmware is downloadable at <http://www.lenovo.com/support>.

Using the EasyUpdate Firmware Updater program

ThinkServer EasyUpdate Firmware Updater is a software application that enables you to maintain your system firmware up to date and helps you avoid unnecessary outages. Firmware Updater updates the server system and adapter firmware.

To update your system, do the following:

1. Go to <http://www.lenovo.com/support>.
2. Click **Download & Drivers** → **ThinkServer** and then follow the instructions on the Web page to download the ISO image for the EasyUpdate Firmware Updater program.
3. Burn the ISO image to a disc.
4. Set the optical drive as the first boot device and insert the disc into the optical drive. The server will proceed directly to the User Interface Application's introductory screen.
5. Read the messages and instructions displayed on the introductory screen. Then, click **Next** to proceed to the list of firmware updates available on the optical media.
6. Click **Apply** to begin the updates (click **Cancel** if you want to abort the updates and exit). All updates will run to completion, with each updater's native user interface kept visible to the user. When the User Interface Application regains control, you will see the results screen.

Before distributing the firmware update to other servers, ensure that your server can restart successfully without encountering hardware problems.

Notes:

1. If you have changed any hardware (except the hard disk drives) in the server, you must reflash the BIOS, the BMC firmware, and the FRU/SDR.
2. After updating the BIOS, all the BIOS settings become the default settings of the updated BIOS version. You need to check and reconfigure the BIOS settings for your specific needs.

Installing the ThinkServer EasyManage program

To install the ThinkServer EasyManage Agent, you must already have a core server running the ThinkServer EasyManage Core Server program. The ThinkServer EasyManage Agent must be installed from that core server. Refer to the ThinkServer EasyManage Core Server documentation about Agent deployment for instructions on the various ways to deploy the ThinkServer EasyManage Agent to your new server.

Also, the ThinkServer EasyStartup program provides an option to install the ThinkServer EasyManage Agent as part of the operating system installation process.

Chapter 7. Troubleshooting

This chapter describes the diagnostic tools that are available to help you solve problems that might occur in the server.

If you cannot diagnose and correct a problem by using the information in this chapter, see Appendix A “Getting help and technical assistance” on page 125 for more information.

Troubleshooting tables

Use the troubleshooting tables to find solutions to problems that have identifiable symptoms.

If you have just added new software or a new optional device and the server is not working, complete the following steps before you use the troubleshooting tables:

1. Check the operator information panel.
2. Remove the software or device that you just added.
3. Reinstall the new software or new device.

DVD drive problems

- Follow the suggested actions in the order in which they are listed in the Action column until the problem is solved.
- See the parts listing in the *Hardware Maintenance Manual* to determine which components are customer replaceable units (CRUs) and which components are field replaceable units (FRUs).
- If an action step is preceded by “(Trained service technician only),” that step must be performed only by a trained service technician.

Symptom	Action
The DVD drive is not recognized.	<ol style="list-style-type: none">1. Make sure that:<ul style="list-style-type: none">• The SATA channel to which the DVD drive is attached (primary or secondary) is enabled in the Setup Utility program.• All cables and jumpers are installed correctly.• The signal cable and connector are not damaged and the connector pins are not bent.• The correct device driver is installed for the DVD drive.2. Reseat the following components:<ol style="list-style-type: none">a. DVD driveb. DVD drive cables3. Replace the following components one at a time, in the order shown, restarting the server each time:<ol style="list-style-type: none">a. DVD driveb. DVD drive and cablesc. (Trained service technician only) System board
A DVD is not working correctly.	<ol style="list-style-type: none">1. Clean the DVD.2. Reseat the DVD drive.3. Replace the DVD drive.

Symptom	Action
The DVD drive tray is not working.	<ol style="list-style-type: none"> 1. Make sure that the server is turned on. 2. Insert the end of a straightened paper clip into the manual tray-release opening. 3. Reseat the DVD drive. 4. Replace the DVD drive.

General problems

- Follow the suggested actions in the order in which they are listed in the Action column until the problem is solved.
- See the parts listing in the *Hardware Maintenance Manual* to determine which components are customer replaceable units (CRUs) and which components are field replaceable units (FRUs).
- If an action step is preceded by “(Trained service technician only),” that step must be performed only by a trained service technician.

Symptom	Action
A cover lock is broken, an LED is not working, or a similar problem has occurred.	If the part is a CRU, replace it. If the part is a FRU, the part must be replaced by a trained service technician.

Hard disk drive problems

- Follow the suggested actions in the order in which they are listed in the Action column until the problem is solved.
- See the parts listing in the *Hardware Maintenance Manual* to determine which components are customer replaceable units (CRUs) and which components are field replaceable units (FRUs).
- If an action step is preceded by “(Trained service technician only),” that step must be performed only by a trained service technician.

Symptom	Action
Not all drives are recognized by the hard disk drive diagnostic tests.	Remove the drive that is indicated by the diagnostic tests; then, run the hard disk drive diagnostic tests again. If the remaining drives are recognized, replace the drive that you removed with a new one.
The server stops responding during the hard disk drive diagnostic test.	Remove the hard disk drive that was being tested when the server stopped responding, and run the diagnostic test again. If the hard disk drive diagnostic test runs successfully, replace the drive that you removed with a new one.
A hard disk drive was not detected while the operating system was being started.	Reseat all hard disk drives and cables; then, run the hard disk drive diagnostic tests again.

Intermittent problems

- Follow the suggested actions in the order in which they are listed in the Action column until the problem is solved.
- See the parts listing in the *Hardware Maintenance Manual* to determine which components are customer replaceable units (CRUs) and which components are field replaceable units (FRUs).
- If an action step is preceded by “(Trained service technician only),” that step must be performed only by a trained service technician.

Symptom	Action
A problem occurs only occasionally and is difficult to diagnose.	<ol style="list-style-type: none"> 1. Make sure that: <ul style="list-style-type: none"> • All cables and cords are connected securely to the rear of the server and attached devices. • When the server is turned on, air is flowing from the fan grille. If there is no airflow, the fan is not working. This can cause the server to overheat and shut down. 2. Check the system-event log (see “Event logs” on page 122). 3. See “Solving undetermined problems” on page 121.

Keyboard, mouse, or pointing-device problems

- Follow the suggested actions in the order in which they are listed in the Action column until the problem is solved.
- See the parts listing in the *Hardware Maintenance Manual* to determine which components are customer replaceable units (CRUs) and which components are field replaceable units (FRUs).
- If an action step is preceded by “(Trained service technician only),” that step must be performed only by a trained service technician.

Symptom	Action
All or some keys on the keyboard do not work.	<ol style="list-style-type: none"> 1. Make sure that: <ul style="list-style-type: none"> • The keyboard cable is securely connected. • The server and the monitor are turned on. 2. The keyboard is compatible with the server. Refer to the Web site at http://www.lenovo.com/thinkserver. 3. If you are using a USB keyboard and it is connected to a USB hub, disconnect the keyboard from the hub and connect it directly to the server. 4. Replace the following components one at a time, in the order shown, restarting the server each time: <ol style="list-style-type: none"> a. Keyboard b. (Trained service technician only) System board
The mouse or pointing device does not work.	<ol style="list-style-type: none"> 1. Make sure that: <ul style="list-style-type: none"> • The mouse or pointing device is compatible with the server. Refer to the Web site at http://www.lenovo.com/thinkserver. • The mouse or pointing-device cable is securely connected to the server. • The mouse or pointing-device device drivers are installed correctly. • The server and the monitor are turned on. • The mouse is enabled in the Setup Utility program. 2. If you are using a USB mouse or pointing device and it is connected to a USB hub, disconnect the mouse or pointing device from the hub and connect it directly to the server. 3. Replace the following components one at a time, in the order shown, restarting the server each time: <ol style="list-style-type: none"> a. Mouse or pointing device b. (Trained service technician only) System board

Memory problems

- Follow the suggested actions in the order in which they are listed in the Action column until the problem is solved.

- See the parts listing in the *Hardware Maintenance Manual* to determine which components are customer replaceable units (CRUs) and which components are field replaceable units (FRUs).
- If an action step is preceded by “(Trained service technician only),” that step must be performed only by a trained service technician.

Symptom	Action
<p>The amount of system memory that is displayed is less than the amount of installed physical memory.</p>	<ol style="list-style-type: none"> 1. Make sure that: <ul style="list-style-type: none"> • No error LEDs are lit on the operator information panel or on the DIMM. • Memory mirroring does not account for the discrepancy. • The memory modules are seated correctly. • You have installed the correct type of memory. • If you changed the memory, you updated the memory configuration in the Setup Utility program. • All banks of memory are enabled. The server might have automatically disabled a memory bank when it detected a problem, or a memory bank might have been manually disabled. 2. Check the POST event log for DIMM error messages: <ul style="list-style-type: none"> • If a DIMM was disabled by a systems-management interrupt (SMI), replace the DIMM. • If a DIMM was disabled by the user or by POST, run the Setup Utility program and enable the DIMM. 3. Make sure that there is no memory mismatch when the server is at the minimum memory configuration. 4. Add one pair of DIMMs at a time, making sure that the DIMMs in each pair are matching. 5. Reseat the DIMMs. 6. Replace the DIMMs in step 5 on page 114, one at a time, in the order shown, restarting the server each time.
<p>Multiple rows of DIMMs in a branch are identified as failing.</p>	<ol style="list-style-type: none"> 1. Reseat the DIMMs; then, restart the server. 2. Replace the lowest-numbered DIMMs with identical known good DIMMs; then, restart the server. Repeat as necessary. If the failures continue after all identified pairs are replaced, go to step 4 on page 114. 3. Return the removed DIMMs, one pair at a time, to their original connectors, restarting the server after each pair, until a pair fails. Replace each DIMM in the failed pair with an identical known good DIMM, restarting the server after you reinstall each DIMM. Replace the failed DIMM. Repeat step 3 on page 114 until you have tested all removed DIMMs. 4. (Trained service technician only) Replace the system board.

Microprocessor problems

- Follow the suggested actions in the order in which they are listed in the Action column until the problem is solved.
- See the parts listing in the *Hardware Maintenance Manual* to determine which components are customer replaceable units (CRUs) and which components are field replaceable units (FRUs).
- If an action step is preceded by “(Trained service technician only),” that step must be performed only by a trained service technician.

Symptom	Action
The server emits a continuous beep during the POST, indicating that the startup (boot) microprocessor is not working correctly.	<ol style="list-style-type: none"> 1. Make sure that the server supports all the microprocessors and that the microprocessors match in speed and cache size. 2. (Trained service technician only) Reseat microprocessor 1. 3. (Trained service technician only) If there is no indication of which microprocessor has failed, isolate the error by testing with one microprocessor at a time. 4. Replace the following components one at a time, in the order shown, restarting the server each time: <ol style="list-style-type: none"> a. (Trained service technician only) Microprocessor 2 b. VRM 2 c. (Trained service technician only) System board 5. (Trained service technician only) If multiple error codes indicate a microprocessor error, reverse the locations of two microprocessors to determine whether the error is associated with a microprocessor or with a microprocessor socket. <ul style="list-style-type: none"> • If the error is associated with a microprocessor, replace the microprocessor. • If the error is associated with a VRM, replace the VRM. • If the error is associated with a microprocessor socket, replace the system board.

Monitor problems

Some monitors have their own self-tests. If you suspect a problem with your monitor, see the documentation that comes with the monitor for instructions for testing and adjusting the monitor.

- Follow the suggested actions in the order in which they are listed in the Action column until the problem is solved.
- See the parts listing in the *Hardware Maintenance Manual* to determine which components are customer replaceable units (CRUs) and which components are field replaceable units (FRUs).
- If an action step is preceded by “(Trained service technician only),” that step must be performed only by a trained service technician.

Symptom	Action
Testing the monitor	<ol style="list-style-type: none"> 1. Make sure that the monitor cables are firmly connected. 2. Try using a different monitor on the server, or try using the monitor that is being tested on a different server. 3. Run the diagnostic programs. If the monitor passes the diagnostic programs, the problem might be a video device driver. 4. (Trained service technician only) Replace the system board.
The screen is blank.	<ol style="list-style-type: none"> 1. If the server is attached to a KVM switch, bypass the KVM switch to eliminate it as a possible cause of the problem: connect the monitor cable directly to the correct connector on the rear of the server. 2. Make sure that: <ul style="list-style-type: none"> • The server is turned on. If there is no power to the server, see “Power problems” on page 117. • The monitor cables are connected correctly. • The monitor is turned on and the brightness and contrast controls are adjusted correctly. • No POST errors are generated when the server is turned on. 3. Make sure that the correct server is controlling the monitor, if applicable. 4. See “Solving undetermined problems” on page 121.

Symptom	Action
The monitor has screen jitter, or the screen image is wavy, unreadable, rolling, or distorted.	<ol style="list-style-type: none"> If the monitor self-tests show that the monitor is working correctly, consider the location of the monitor. Magnetic fields around other devices (such as transformers, appliances, fluorescent lights, and other monitors) can cause screen jitter or wavy, unreadable, rolling, or distorted screen images. If this happens, turn off the monitor. Attention: Moving a color monitor while it is turned on might cause screen discoloration. Move the device and the monitor at least 305 mm (12 inches) apart, and turn on the monitor. To prevent diskette drive read/write errors, make sure that the distance between the monitor and any external diskette drive is at least 76 mm (3 inches). Reseat the monitor. Replace the following components one at a time, in the order shown, restarting the server each time: <ol style="list-style-type: none"> Monitor (Trained service technician only) System board
Wrong characters appear on the screen.	<ol style="list-style-type: none"> If the wrong language is displayed, update the server firmware with the correct language (see “Updating the firmware” on page 109). Reseat the monitor. Replace the following components one at a time, in the order shown, restarting the server each time: <ol style="list-style-type: none"> Monitor (Trained service technician only) System board

Optional-device problems

- Follow the suggested actions in the order in which they are listed in the Action column until the problem is solved.
- See the parts listing in the *Hardware Maintenance Manual* to determine which components are customer replaceable units (CRUs) and which components are field replaceable units (FRUs).
- If an action step is preceded by “(Trained service technician only),” that step must be performed only by a trained service technician.

Symptom	Action
A Lenovo optional device that was just installed does not work.	<ol style="list-style-type: none"> Make sure that: <ul style="list-style-type: none"> The device is designed for the server. For a list of the supported options for your server, go to http://www.lenovo.com/thinkserver. On the ThinkServer systems page, click Products → Options. You followed the installation instructions that came with the device and the device is installed correctly. You have not loosened any other installed devices or cables. You updated the configuration information in the Setup Utility program. Whenever memory or any other device is changed, you must update the configuration. Reseat the device that you just installed. Replace the device that you just installed.

Symptom	Action
A Lenovo optional device that used to work does not work now.	<ol style="list-style-type: none"> 1. Make sure that all of the hardware and cable connections for the device are secure. 2. If the device comes with test instructions, use those instructions to test the device. 3. If the failing device is an SCSI device, make sure that: <ul style="list-style-type: none"> • The cables for all external SCSI devices are connected correctly. • The last device in each SCSI chain, or the end of the SCSI cable, is terminated correctly. • Any external SCSI device is turned on. You must turn on an external SCSI device before you turn on the server. 4. Reseat the failing device. 5. Replace the failing device.

Power problems

- Follow the suggested actions in the order in which they are listed in the Action column until the problem is solved.
- See the parts listing in the *Hardware Maintenance Manual* to determine which components are customer replaceable units (CRUs) and which components are field replaceable units (FRUs).
- If an action step is preceded by “(Trained service technician only),” that step must be performed only by a trained service technician.

Symptom	Action
<p>The power-control button does not work (the server does not start).</p> <p>Note: The power-control button will not function until 3 minutes after the server has been connected to ac power.</p>	<ol style="list-style-type: none"> 1. Make sure that the power-control button is working correctly: <ol style="list-style-type: none"> a. Disconnect the server power cords. b. Reconnect the power cords. c. (Trained service technician only) Reseat the operator information panel cables, and then repeat step a. on page 118 and step b. on page 118. If the server starts, reseat the operator information panel. If the problem remains, replace the operator information panel. 2. Make sure that: <ul style="list-style-type: none"> • The power cords are correctly connected to the server and to a working electrical outlet. • The type of memory that is installed is correct. • The DIMM is fully seated. • The LEDs on the power supply do not indicate a problem. • The microprocessors are installed in the correct sequence. 3. Reseat the following components: <ol style="list-style-type: none"> a. DIMMs b. (Trained service technician only) Power switch connector c. (Trained service technician only) Power backplane 4. Replace the following components one at a time, in the order shown, restarting the server each time: <ol style="list-style-type: none"> a. DIMMs b. (Trained service technician only) Power switch connector c. (Trained service technician only) Power backplane d. (Trained service technician only) System board 5. If you just installed an optional device, remove it, and restart the server. If the server now starts, you might have installed more devices than the power supply supports. 6. See “Solving undetermined problems” on page 121.
<p>The server does not turn off.</p>	<ol style="list-style-type: none"> 1. Determine whether you are using an Advanced Configuration and Power Interface (ACPI) or a non-ACPI operating system. If you are using a non-ACPI operating system, do the following: <ol style="list-style-type: none"> a. Press Ctrl+Alt+Delete. b. Turn off the server by pressing the power-control button for 5 seconds. c. Restart the server. d. If the server fails the POST and the power-control button does not work, disconnect the power cord for 20 seconds; then, reconnect the power cord and restart the server. 2. If the problem remains or if you are using an ACPI-aware operating system, suspect the system board.
<p>The server unexpectedly shuts down, and the LEDs on the operator information panel are not lit.</p>	<p>See “Solving undetermined problems” on page 121.</p>

Serial port problems

- Follow the suggested actions in the order in which they are listed in the Action column until the problem is solved.

- See the parts listing in the *Hardware Maintenance Manual* to determine which components are customer replaceable units (CRUs) and which components are field replaceable units (FRUs).
- If an action step is preceded by “(Trained service technician only),” that step must be performed only by a trained service technician.

Symptom	Action
The number of serial ports that are identified by the operating system is less than the number of installed serial ports.	<ol style="list-style-type: none"> 1. Make sure that: <ul style="list-style-type: none"> • Each port is assigned a unique address in the Setup Utility program and none of the serial ports is disabled. • The serial port adapter (if one is present) is seated correctly. 2. Reseat the serial port adapter. 3. Replace the serial port adapter.
A serial device does not work.	<ol style="list-style-type: none"> 1. Make sure that: <ul style="list-style-type: none"> • The device is compatible with the server. • The serial port is enabled and is assigned a unique address. • The device is connected to the correct connector. 2. Reseat the following components: <ol style="list-style-type: none"> a. Failing serial device b. Serial cable 3. Replace the following components one at a time, in the order shown, restarting the server each time: <ol style="list-style-type: none"> a. Failing serial device b. Serial cable c. (Trained service technician only) System board

Software problems

- Follow the suggested actions in the order in which they are listed in the Action column until the problem is solved.
- See the parts listing in the *Hardware Maintenance Manual* to determine which components are customer replaceable units (CRUs) and which components are field replaceable units (FRUs).
- If an action step is preceded by “(Trained service technician only),” that step must be performed only by a trained service technician.

Symptom	Action
You suspect a software problem.	<ol style="list-style-type: none"> 1. To determine whether the problem is caused by the software, make sure that: <ul style="list-style-type: none"> • The server has the minimum memory that is needed to use the software. For memory requirements, see the information that comes with the software. If you have just installed an adapter or memory, the server might have a memory-address conflict. • The software is designed to operate on the server. • Other software works on the server. • The software works on another server. 2. If you receive any error messages while you use the software, see the information that comes with the software for a description of the messages and suggested solutions to the problem. 3. Contact the software vendor.

Universal Serial Bus (USB) port problems

- Follow the suggested actions in the order in which they are listed in the Action column until the problem is solved.
- See the parts listing in the *Hardware Maintenance Manual* to determine which components are customer replaceable units (CRUs) and which components are field replaceable units (FRUs).
- If an action step is preceded by “(Trained service technician only),” that step must be performed only by a trained service technician.

Symptom	Action
A USB device does not work.	<ol style="list-style-type: none">1. Make sure that:<ul style="list-style-type: none">• The correct USB device driver is installed.• The operating system supports USB devices.• A standard PS/2 keyboard or mouse is not connected to the server. If it is, a USB keyboard or mouse will not work during the POST.2. Make sure that the USB configuration optional devices are set correctly in the Setup Utility program.3. If you are using a USB hub, disconnect the USB device from the hub and connect it directly to the server.

Solving power problems

Power problems can be difficult to solve. For example, a short circuit can exist anywhere on any of the power distribution buses. Usually, a short circuit will cause the power subsystem to shut down because of an overcurrent condition. To diagnose a power problem, use the following general procedure:

1. Turn off the server and disconnect all ac power cords.
2. Check for loose cables in the power subsystem. Also check for short circuits, for example, if a loose screw is causing a short circuit on a circuit board.
3. Remove the adapters and disconnect the cables and power cords to all internal and external devices until the server is at the minimum configuration that is required for the server to start (see “Solving undetermined problems” on page 121 for the minimum configuration).
4. Reconnect all ac power cords and turn on the server. If the server starts successfully, replace the adapters and devices one at a time until the problem is isolated.

If the server does not start from the minimum configuration, replace the components in the minimum configuration one at a time until the problem is isolated.

Solving Ethernet controller problems

The method that you use to test the Ethernet controller depends on which operating system you are using. See the operating-system documentation for information about Ethernet controllers, and see the Ethernet controller device-driver readme file.

Try the following procedures:

- Make sure that the correct device drivers, which come with the server, are installed and that they are at the latest level.
- Make sure that the Ethernet cable is installed correctly.
 - The cable must be securely attached at all connections. If the cable is attached but the problem remains, try a different cable.
 - If the Ethernet controller is set to operate at 100 Mbps, you must use Category 5 cabling.

- If you directly connect two servers (without a hub), or if you are not using a hub with X ports, use a crossover cable. To determine whether a hub has an X port, check the port label. If the label contains an X, the hub has an X port.
- Determine whether the hub supports auto-negotiation. If it does not, try configuring the integrated Ethernet controller manually to match the speed and duplex mode of the hub.
- Check the Ethernet controller LEDs on the rear panel of the server. These LEDs indicate whether there is a problem with the connector, cable, or hub.
 - The Ethernet link status LED is lit when the Ethernet controller receives a link pulse from the hub. If the LED is off, there might be a defective connector or cable or a problem with the hub.
 - The Ethernet transmit/receive activity LED is lit when the Ethernet controller sends or receives data over the Ethernet network. If the Ethernet transmit/receive activity LED is off, make sure that the hub and network are operating and that the correct device drivers are installed.
- Check the LAN activity LEDs on the rear of the server. The LAN activity LED is lit when data is active on the Ethernet network. If the LAN activity LED is off, make sure that the hub and network are operating and that the correct device drivers are installed.
- Check for operating-system-specific causes of the problem.
- Make sure that the device drivers on the client and server are using the same protocol.

If the Ethernet controller still cannot connect to the network but the hardware appears to be working, the network administrator must investigate other possible causes of the error.

Solving undetermined problems

If the diagnostic tests did not diagnose the failure or if the server is inoperative, use the information in this section.

If you suspect that a software problem is causing failures (continuous or intermittent), see “Software problems” on page 119.

Damaged data in CMOS memory or damaged firmware can cause undetermined problems. To reset the CMOS data, use the password switch 2 (SW4) to override the power-on password and clear the CMOS memory; see “Locating parts on the system board” on page 15.

Check the LEDs on all the power supplies. If the LEDs indicate that the power supplies are working correctly, do the following:

1. Turn off the server.
2. Make sure that the server is cabled correctly.
3. Remove or disconnect the following devices, one at a time, until you find the failure. Turn on the server and reconfigure it each time.
 - Any external devices
 - Surge-suppressor device (on the server)
 - Modem, printer, mouse, and non-Lenovo devices
 - Each adapter
 - Hard disk drives
 - Memory modules: the minimum configuration requirement is 1 GB DIMM per microprocessor (2 GB in a two-microprocessor configuration)

The following minimum configuration is required for the server to start:

- One microprocessor
 - One 2 GB DIMM
 - One power supply
 - Power cord
 - Server RAID SAS adapter
 - System board assembly
4. Turn on the server. If the problem remains, suspect the following components in the following order:
 - a. Power supply

- b. Power-supply cage
- c. Memory
- d. Microprocessor
- e. System board

If the problem is solved when you remove an adapter from the server but the problem recurs when you reinstall the same adapter, suspect the adapter; if the problem recurs when you replace the adapter with a different one, suspect the system board or extender card.

If you suspect a networking problem and the server passes all the system tests, suspect a network cabling problem that is external to the server.

Event logs

Error codes and messages are displayed in the following types of event logs:

- **POST event log:** This log contains the three most recent error codes and messages that were generated during the POST.
- **System-event log:** This log contains all the POST and system management interrupt (SMI) events.

System event log

The BMC implements the system event log (SEL) as specified in the Intelligent Platform Management Interface Specification, Version 2.0. The SEL is accessible regardless of the system power state via the BMC's in-band and out-of-band interfaces.

Diagnostic programs and messages

Whenever possible, the BIOS outputs the current boot progress codes on the video screen. Progress codes are 32-bit quantities plus optional data. The 32-bit numbers include class, subclass, and operation information. The class and subclass fields point to the type of hardware being initialized. The operation field represents the specific initialization activity. Based on the data bit availability to display progress codes, a progress code can be customized to fit the data width. The higher the data bit, the higher the granularity of information that can be sent on the progress port. The progress codes may be reported by the system BIOS or option ROMs.

The response has three types:

- **Minor:** The message displays on the screen or on the Error Manager screen, and an error is logged to the SEL. The system continues booting in a degraded state. The user may want to replace the erroneous unit. The POST Error Pause option setting in the BIOS setup does not have any effect on this error.
- **Major:** The message displays on the Error Manager screen, and an error is logged to the SEL. The POST Error Pause option setting in the BIOS setup determines whether the system pauses to the Error Manager for this type of error so that the user can take immediate corrective action or the system continues booting.

Note: For 0048 (Password check failed), the system will halt, and then after the next reset/reboot displays the error code on the Error Manager screen.

- **Fatal:** The system halts during the POST at a blank screen with the text "Unrecoverable fatal error found. System will not boot until the error is resolved" and "Press <F2> to enter setup." The POST Error Pause option setting in the BIOS setup does not have any effect with this class of error. When you press F2 on the keyboard, the error message is displayed on the Error Manager screen, and an error is logged to the SEL with the error code. The system cannot boot unless the error is resolved. The user must replace the faulty part and restart the system.

Diagnostic LEDs on the front panel and the system board

Identifying the diagnostic LEDs on the front panel and the system board is a very important method for diagnosing server problems. See “Front view” on page 9 and “Locating diagnostic LEDs on the system board” on page 16 for detailed information.

Appendix A. Getting help and technical assistance

If you need help, service, or technical assistance or just want more information about Lenovo products, you will find a wide variety of sources available from Lenovo to assist you. This section contains information about where to go for additional information about Lenovo and Lenovo products, what to do if you experience a problem with your system, and whom to call for service, if it is necessary.

Before you call

Before you call, make sure that you have taken these steps to try to solve the problem yourself:

- Check all cables to make sure that they are connected.
- Check the power switches to make sure that the system and any optional devices are turned on.
- Use the troubleshooting information in your system documentation, and use the diagnostic tools that come with your system. For the information about diagnostic tools, see Chapter 7 “Troubleshooting” on page 111.
- Go to <http://www.lenovo.com/support> to check for technical information, hints, tips, and new device drivers or to submit a request for information.

You can solve many problems without outside assistance by using the information available on the Lenovo Support site or by following the troubleshooting procedures that Lenovo provides in the documentation that is provided with your Lenovo product. The documentation that comes with Lenovo systems also describes the diagnostic tests that you can perform. Most systems, operating systems, and programs come with documentation that contains troubleshooting procedures and explanations of error messages and error codes. If you suspect a software problem, see the documentation for the operating system or program.

Using the documentation

Information about your Lenovo system and preinstalled software, if any, or optional device is available in the documentation that comes with the product. That documentation can include printed documents, online documents, readme files, and help files. Most of the documentation for your server is on the *ThinkServer Documentation DVD* provided with your server. See the troubleshooting information in your system documentation for instructions for using the diagnostic programs. The troubleshooting information or the diagnostic programs might tell you that you need additional or updated device drivers or other software. Lenovo maintains pages on the World Wide Web where you can get the latest technical information and download device drivers and updates. To access these pages, go to <http://www.lenovo.com/support> and follow the instructions.

Getting help and information from the World Wide Web

On the World Wide Web, the Lenovo Web site has up-to-date information about Lenovo systems, optional devices, services, and support. For general information about Lenovo products or to purchase Lenovo products, go to <http://www.lenovo.com>. For support on Lenovo products, go to: <http://www.lenovo.com/support>

Lenovo Support Web site

Technical support information is available at:
<http://www.lenovo.com/support>

This portal is updated with the latest information about the following subjects:

Downloads and Drivers	Download drivers, flash BIOS, and update your software.
Warranty	Check your warranty status and upgrade your warranty.
Technical Support	Click Need Help? for self-help tips to help diagnose a problem.
ThinkVantage	Learn more about ThinkVantage software to improve productivity and reduce cost.
Lenovo Forums	Search the community knowledge base for your computer to share and discover information with other users.
User Guides & Manuals	Read or print any publications related to your product.

Calling for service

During the warranty period, you can get help and information by telephone through the Customer Support Center.

These services are available during the warranty period:

- **Problem determination** - Trained personnel are available to assist you with determining a hardware problem and deciding what action is necessary to fix the problem.
- **Hardware repair** - If the problem is caused by hardware under warranty, trained service personnel are available to provide the applicable level of service.
- **Engineering Change management** - There might be changes that are required after a product has been sold. Lenovo or your reseller will make selected Engineering Changes (ECs) available that apply to your hardware.

These items are not covered by the warranty:

- Replacement or use of parts not manufactured for or by Lenovo or non-warranted Lenovo parts
- Identification of software problem sources
- Configuration of the BIOS as part of an installation or upgrade
- Changes, modifications, or upgrades to device drivers
- Installation and maintenance of network operating systems (NOS)
- Installation and maintenance of application programs

Refer to the safety and warranty information that is provided with your computer for a complete explanation of warranty terms. You must retain your proof of purchase to obtain warranty service.

For a list of service and support phone numbers for your country or region, go to <http://www.lenovo.com/support> and click **Support phone list** or refer to the safety and warranty information provided with your computer.

Note: Phone numbers are subject to change without notice. If the number for your country or region is not provided, contact your Lenovo reseller or Lenovo marketing representative.

If possible, be at your computer when you call. Have the following information available:

- Machine type and model
- Serial numbers of our hardware products
- Description of the problem
- Exact wording of any error messages
- Hardware and software configuration information

Using other services

If you travel with a Lenovo notebook computer or relocate your computer to a country where your desktop, notebook, or server machine type is sold, your computer might be eligible for International Warranty Service, which automatically entitles you to obtain warranty service throughout the warranty period. Service will be performed by service providers authorized to perform warranty service.

Service methods and procedures vary by country, and some services might not be available in all countries. International Warranty Service is delivered through the method of service (such as depot, carry-in, or on-site service) that is provided in the servicing country. Service centers in certain countries might not be able to service all models of a particular machine type. In some countries, fees and restrictions might apply at the time of service.

To determine whether your computer is eligible for International Warranty Service and to view a list of the countries where service is available, go to <http://www.lenovo.com/support>, click **Warranty**, and follow the instructions on the screen.

For technical assistance with the installation of, or questions related to, Service Packs for your preinstalled Microsoft Windows product, refer to the Microsoft Product Support Services Web site at <http://www.support.microsoft.com/directory/>, or you can contact the Customer Support Center. Some fees might apply.

Purchasing additional services

During and after the warranty period, you can purchase additional services, such as support for hardware, operating systems, and application programs; network setup and configuration; upgraded or extended hardware repair services; and custom installations. Service availability and service name might vary by country or region. For more information about these services, go to the Lenovo Web site at <http://www.lenovo.com/>.

Lenovo product service information for Taiwan

台灣 Lenovo 產品服務資訊如下：
荷蘭商聯想股份有限公司台灣分公司
台北市信義區信義路五段七號十九樓之一
服務電話：0800-000-702

Appendix B. Notices

Lenovo may not offer the products, services, or features discussed in this document in all countries. Consult your local Lenovo representative for information on the products and services currently available in your area. Any reference to a Lenovo product, program, or service is not intended to state or imply that only that Lenovo product, program, or service may be used. Any functionally equivalent product, program, or service that does not infringe any Lenovo intellectual property right may be used instead. However, it is the user's responsibility to evaluate and verify the operation of any other product, program, or service.

Lenovo may have patents or pending patent applications covering subject matter described in this document. The furnishing of this document does not give you any license to these patents. You can send license inquiries, in writing, to:

*Lenovo (United States), Inc.
1009 Think Place - Building One
Morrisville, NC 27560
U.S.A.
Attention: Lenovo Director of Licensing*

LENOVO PROVIDES THIS PUBLICATION "AS IS" WITHOUT WARRANTY OF ANY KIND, EITHER EXPRESS OR IMPLIED, INCLUDING, BUT NOT LIMITED TO, THE IMPLIED WARRANTIES OF NON-INFRINGEMENT, MERCHANTABILITY OR FITNESS FOR A PARTICULAR PURPOSE. Some jurisdictions do not allow disclaimer of express or implied warranties in certain transactions, therefore, this statement may not apply to you.

This information could include technical inaccuracies or typographical errors. Changes are periodically made to the information herein; these changes will be incorporated in new editions of the publication. Lenovo may make improvements and/or changes in the product(s) and/or the program(s) described in this publication at any time without notice.

The products described in this document are not intended for use in implantation or other life support applications where malfunction may result in injury or death to persons. The information contained in this document does not affect or change Lenovo product specifications or warranties. Nothing in this document shall operate as an express or implied license or indemnity under the intellectual property rights of Lenovo or third parties. All information contained in this document was obtained in specific environments and is presented as an illustration. The result obtained in other operating environments may vary.

Lenovo may use or distribute any of the information you supply in any way it believes appropriate without incurring any obligation to you.

Any references in this publication to non-Lenovo Web sites are provided for convenience only and do not in any manner serve as an endorsement of those Web sites. The materials at those Web sites are not part of the materials for this Lenovo product, and use of those Web sites is at your own risk.

Any performance data contained herein was determined in a controlled environment. Therefore, the result obtained in other operating environments may vary significantly. Some measurements may have been made on development-level systems and there is no guarantee that these measurements will be the same on generally available systems. Furthermore, some measurements may have been estimated through extrapolation. Actual results may vary. Users of this document should verify the applicable data for their specific environment.

Trademarks

Lenovo, the Lenovo logo, and ThinkServer are trademarks of Lenovo in the United States, other countries, or both.

Intel and Intel Xeon are trademarks of Intel Corporation in the United States, other countries, or both.

Microsoft and Windows are trademarks of the Microsoft group of companies.

Linux is a trademark of Linus Torvalds in the United States, other countries, or both.

Red Hat and all Red Hat-based trademarks and logos are trademarks or registered trademarks of Red Hat, Inc., in the United States and other countries.

Other company, product, or service names may be trademarks or service marks of others.

Important notes

Processor speed indicates the internal clock speed of the microprocessor; other factors also affect application performance.

CD or DVD drive speed is the variable read rate. Actual speeds vary and are often less than the possible maximum.

When referring to processor storage, real and virtual storage, or channel volume, KB stands for 1024 bytes, MB stands for 1,048,576 bytes, and GB stands for 1,073,741,824 bytes.

When referring to hard disk drive capacity or communications volume, MB stands for 1,000,000 bytes, and GB stands for 1,000,000,000 bytes. Total user-accessible capacity can vary depending on operating environments.

Maximum internal hard disk drive capacities assume the replacement of any standard hard disk drives and population of all hard disk drive bays with the largest currently supported drives that are available from Lenovo.

Maximum memory might require replacement of the standard memory with an optional memory module.

Lenovo makes no representation or warranties regarding non-Lenovo products and services, including but not limited to the implied warranties of merchantability and fitness for a particular purpose. These products are offered and warranted solely by third parties.

Some software might differ from its retail version (if available) and might not include user manuals or all program functionality.

Product recycling and disposal

This unit must be recycled or discarded according to applicable local and national regulations. Lenovo encourages owners of information technology (IT) equipment to responsibly recycle their equipment when it is no longer needed. Lenovo offers a variety of programs and services to assist equipment owners in recycling their IT products. Information on Lenovo product recycling offerings can be found on Lenovo's Internet site at <http://www.lenovo.com/lenovo/environment/recycling>.

Esta unidad debe reciclarse o desecharse de acuerdo con lo establecido en la normativa nacional o local aplicable. Lenovo recomienda a los propietarios de equipos de tecnología de la información (TI) que reciclen

responsablemente sus equipos cuando éstos ya no les sean útiles. Lenovo dispone de una serie de programas y servicios de devolución de productos, a fin de ayudar a los propietarios de equipos a reciclar sus productos de TI. Se puede encontrar información sobre las ofertas de reciclado de productos de Lenovo en el sitio web de Lenovo

<http://www.lenovo.com/lenovo/environment/recycling>.

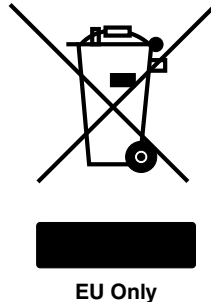

Notice: This mark applies only to countries within the European Union (EU) and Norway.

This appliance is labeled in accordance with European Directive 2002/96/EC concerning waste electrical and electronic equipment (WEEE). The Directive determines the framework for the return and recycling of used appliances as applicable throughout the European Union. This label is applied to various products to indicate that the product is not to be thrown away, but rather reclaimed upon end of life per this Directive.

注意: このマークは EU 諸国およびノルウェーにおいてのみ適用されます。

この機器には、EU 諸国に対する廃電気電子機器指令 2002/96/EC(WEEE) のラベルが貼られています。この指令は、EU 諸国に適用する使用済み機器の回収とリサイクルの骨子を定めています。このラベルは、使用済みになった時に指令に従って適正な処理をする必要があることを知らせるために種々の製品に貼られています。

Remarque : Cette marque s'applique uniquement aux pays de l'Union Européenne et à la Norvège.

L'étiquette du système respecte la Directive européenne 2002/96/EC en matière de Déchets des Equipements Electriques et Electroniques (DEEE), qui détermine les dispositions de retour et de recyclage applicables aux systèmes utilisés à travers l'Union européenne. Conformément à la directive, ladite étiquette précise que le produit sur lequel elle est apposée ne doit pas être jeté mais être récupéré en fin de vie.

In accordance with the European WEEE Directive, electrical and electronic equipment (EEE) is to be collected separately and to be reused, recycled, or recovered at end of life. Users of EEE with the WEEE marking per Annex IV of the WEEE Directive, as shown above, must not dispose of end of life EEE as unsorted municipal waste, but use the collection framework available to customers for the return, recycling, and recovery of WEEE. Customer participation is important to minimize any potential effects of EEE on the environment and human health due to the potential presence of hazardous substances in EEE. For proper collection and treatment, contact your local Lenovo representative.

Particulate contamination

Attention: Airborne particulates (including metal flakes or particles) and reactive gases acting alone or in combination with other environmental factors such as humidity or temperature might pose a risk to the server that is described in this document. Risks that are posed by the presence of excessive particulate levels or concentrations of harmful gases include damage that might cause the server to malfunction or cease functioning altogether. This specification sets forth limits for particulates and gases that are intended to avoid such damage. The limits must not be viewed or used as definitive limits, because numerous other factors, such as temperature or moisture content of the air, can influence the impact of particulates or environmental corrosives and gaseous contaminant transfer. In the absence of specific limits that are

set forth in this document, you must implement practices that maintain particulate and gas levels that are consistent with the protection of human health and safety. If Lenovo determines that the levels of particulates or gases in your environment have caused damage to the server, Lenovo may condition provision of repair or replacement of servers or parts on implementation of appropriate remedial measures to mitigate such environmental contamination. Implementation of such remedial measures is a customer responsibility.

Table 25. Limits for particulates and gases

Contaminant	Limits
Particulate	<ul style="list-style-type: none"> The room air must be continuously filtered with 40% atmospheric dust spot efficiency (MERV 9) according to ASHRAE Standard 52.2¹. Air that enters a data center must be filtered to 99.97% efficiency or greater, using high-efficiency particulate air (HEPA) filters that meet MIL-STD-282. The deliquescent relative humidity of the particulate contamination must be more than 60%². The room must be free of conductive contamination such as zinc whiskers.
Gaseous	<ul style="list-style-type: none"> Copper: Class G1 as per ANSI/ISA 71.04-1985³ Silver: Corrosion rate of less than 300 Å in 30 days
<p>¹ ASHRAE 52.2-2008 - <i>Method of Testing General Ventilation Air-Cleaning Devices for Removal Efficiency by Particle Size</i>. Atlanta: American Society of Heating, Refrigerating and Air-Conditioning Engineers, Inc.</p> <p>² The deliquescent relative humidity of particulate contamination is the relative humidity at which the dust absorbs enough water to become wet and promote ionic conduction.</p> <p>³ ANSI/ISA-71.04-1985. <i>Environmental conditions for process measurement and control systems: Airborne contaminants</i>. Instrument Society of America, Research Triangle Park, North Carolina, U.S.A.</p>	

Turkish statement of compliance

The Lenovo product meets the requirements of the Republic of Turkey Directive on the Restriction of the Use of Certain Hazardous Substances in Electrical and Electronic Equipment (EEE).

Türkiye EEE Yönetmeliğine Uygunluk Beyanı

Bu Lenovo ürünü, T.C. Çevre ve Orman Bakanlığı'nın "Elektrik ve Elektronik Eşyalarda Bazı Zararlı Maddelerin Kullanımının Sınırlanırılmasına Dair Yönetmelik (EEE)" direktiflerine uygundur.

EEE Yönetmeliğine Uygundur.

Battery return program

This product may contain a lithium or lithium ion battery. Consult your user manual or service manual for specific battery information. The battery must be recycled or disposed of properly. Recycling facilities may not be available in your area. For information on disposal or batteries outside the United States, go to <http://www.lenovo.com/lenovo/environment> or contact your local waste disposal facility.



US & Canada Only

For Taiwan: Please recycle batteries.



廢電池請回收

For the European Union:

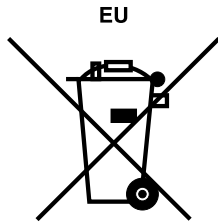

Notice: This mark applies only to countries within the European Union (EU).

Batteries or packaging for batteries are labeled in accordance with European Directive 2006/66/EC concerning batteries and accumulators and waste batteries and accumulators. The Directive determines the framework for the return and recycling of used batteries and accumulators as applicable throughout the European Union. This label is applied to various batteries to indicate that the battery is not to be thrown away, but rather reclaimed upon end of life per this Directive.

Les batteries ou emballages pour batteries sont étiquetés conformément aux directives européennes 2006/66/EC, norme relative aux batteries et accumulateurs en usage et aux batteries et accumulateurs usés. Les directives déterminent la marche à suivre en vigueur dans l'Union Européenne pour le retour et le recyclage des batteries et accumulateurs usés. Cette étiquette est appliquée sur diverses batteries pour indiquer que la batterie ne doit pas être mise au rebut mais plutôt récupérée en fin de cycle de vie selon cette norme.

In accordance with the European Directive 2006/66/EC, batteries and accumulators are labeled to indicate that they are to be collected separately and recycled at end of life. The label on the battery may also include a chemical symbol for the metal concerned in the battery (Pb for lead, Hg for mercury, and Cd for cadmium). Users of batteries and accumulators must not dispose of batteries and accumulators as unsorted municipal waste, but use the collection framework available to customers for the return, recycling, and treatment of batteries and accumulators. Customer participation is important to minimize any potential effects of batteries and accumulators on the environment and human health due to the potential presence of hazardous substances. For proper collection and treatment, go to <http://www.lenovo.com/lenovo/environment>.

For California:

Perchlorate material - special handling may apply. See <http://www.dtsc.ca.gov/hazardouswaste/perchlorate/>.

The foregoing notice is provided in accordance with California Code of Regulations Title 22, Division 4.5 Chapter 33. Best Management Practices for Perchlorate Materials. This product/part may include a lithium manganese dioxide battery which contains a perchlorate substance.

German Ordinance for Work gloss statement

The product is not suitable for use with visual display work place devices according to clause 2 of the German Ordinance for Work with Visual Display Units.

Das Produkt ist nicht für den Einsatz an Bildschirmarbeitsplätzen im Sinne § 2 der Bildschirmarbeitsverordnung geeignet.

Electronic emission notices

The following information applies to Lenovo ThinkServer TD230 server machine types 1027, 1029, 1039, and 1040.

Federal Communications Commission (FCC) Statement

This equipment has been tested and found to comply with the limits for a Class A digital device, pursuant to Part 15 of the FCC Rules. These limits are designed to provide reasonable protection against harmful interference when the equipment is operated in a commercial environment. This equipment generates, uses, and can radiate radio frequency energy and, if not installed and used in accordance with the instruction manual, may cause harmful interference to radio communications. Operation of this equipment in a residential area is likely to cause harmful interference in which case the user will be required to correct the interference at his own expense.

Properly shielded and grounded cables and connectors must be used in order to meet FCC emission limits. Lenovo is not responsible for any radio or television interference caused by using other than specified or recommended cables and connectors or by unauthorized changes or modifications to this equipment. Unauthorized changes or modifications could void the user's authority to operate the equipment.

This device complies with Part 15 of the FCC Rules. Operation is subject to the following two conditions: (1) this device may not cause harmful interference, and (2) this device must accept any interference received, including interference that may cause undesired operation.

Industry Canada Class A emission compliance statement

This Class A digital apparatus complies with Canadian ICES-003.

Cet appareil numérique de la classe A est conforme à la norme NMB-003 du Canada.

United Kingdom telecommunications safety requirement

Notice to Customers

This apparatus is approved under approval number NS/G/1234/J/100003 for indirect connection to public telecommunication systems in the United Kingdom.

European Union - Compliance to the Electromagnetic Compatibility Directive

This product is in conformity with the protection requirements of EU Council Directive 2004/108/EC on the approximation of the laws of the Member States relating to electromagnetic compatibility. Lenovo cannot accept responsibility for any failure to satisfy the protection requirements resulting from a non-recommended modification of the product, including the installation of option cards from other manufacturers.

This product has been tested and found to comply with the limits for Class A Information Technology Equipment according to European Standard EN 55022. The limits for Class A equipment were derived for commercial and industrial environments to provide reasonable protection against interference with licensed communication equipment.



Warning: This is a Class A product. In a domestic environment this product may cause radio interference in which case the user may be required to take adequate measures.

German Class A compliance statement

Deutschsprachiger EU Hinweis:

Hinweis für Geräte der Klasse A EU-Richtlinie zur Elektromagnetischen Verträglichkeit

Dieses Produkt entspricht den Schutzanforderungen der EU-Richtlinie 2004/108/EG (früher 89/336/EWG) zur Angleichung der Rechtsvorschriften über die elektromagnetische Verträglichkeit in den EU-Mitgliedsstaaten und hält die Grenzwerte der EN 55022 Klasse A ein.

Um dieses sicherzustellen, sind die Geräte wie in den Handbüchern beschrieben zu installieren und zu betreiben. Des Weiteren dürfen auch nur von der Lenovo empfohlene Kabel angeschlossen werden. Lenovo übernimmt keine Verantwortung für die Einhaltung der Schutzanforderungen, wenn das Produkt ohne Zustimmung der Lenovo verändert bzw. wenn Erweiterungskomponenten von Fremdherstellern ohne Empfehlung der Lenovo gesteckt/eingebaut werden.

Deutschland:

Einhaltung des Gesetzes über die elektromagnetische Verträglichkeit von Betriebsmitteln

Dieses Produkt entspricht dem „Gesetz über die elektromagnetische Verträglichkeit von Betriebsmitteln“ EMVG (früher „Gesetz über die elektromagnetische Verträglichkeit von Geräten“). Dies ist die Umsetzung der EU-Richtlinie 2004/108/EG (früher 89/336/EWG) in der Bundesrepublik Deutschland.

Zulassungsbescheinigung laut dem Deutschen Gesetz über die elektromagnetische Verträglichkeit von Betriebsmitteln, EMVG vom 20. Juli 2007 (früher Gesetz über die elektromagnetische Verträglichkeit von Geräten), bzw. der EMV EG Richtlinie 2004/108/EC (früher 89/336/EWG), für Geräte der Klasse A.

Dieses Gerät ist berechtigt, in Übereinstimmung mit dem Deutschen EMVG das EG-Konformitätszeichen - CE - zu führen. Verantwortlich für die Konformitätserklärung nach Paragraf 5 des EMVG ist die Lenovo (Deutschland) GmbH, Gropiusplatz 10, D-70563 Stuttgart.

Informationen in Hinsicht EMVG Paragraf 4 Abs. (1) 4:

Das Gerät erfüllt die Schutzanforderungen nach EN 55024 und EN 55022 Klasse A.

Nach der EN 55022: „Dies ist eine Einrichtung der Klasse A. Diese Einrichtung kann im Wohnbereich Funkstörungen verursachen; in diesem Fall kann vom Betreiber verlangt werden, angemessene Maßnahmen durchzuführen und dafür aufzukommen.“

Nach dem EMVG: „Geräte dürfen an Orten, für die sie nicht ausreichend entstört sind, nur mit besonderer Genehmigung des Bundesministers für Post und Telekommunikation oder des Bundesamtes für Post und Telekommunikation betrieben werden. Die Genehmigung wird erteilt, wenn keine elektromagnetischen Störungen zu erwarten sind.“ (Auszug aus dem EMVG, Paragraph 3, Abs. 4). Dieses Genehmigungsverfahren ist nach Paragraph 9 EMVG in Verbindung mit der entsprechenden Kostenverordnung (Amtsblatt 14/93) kostenpflichtig.

Anmerkung: Um die Einhaltung des EMVG sicherzustellen sind die Geräte, wie in den Handbüchern angegeben, zu installieren und zu betreiben.

Korea Class A compliance statement

사용자 안내문(A급 기기)
업무용 방송통신기기

이 기기는 업무용(A급)으로 전자파적합등록을 한 기기이오니 판매자 또는 사용자는 이 점을 주의하시기 바라며,가정외의 지역에서 사용하는 것을 목적으로 합니다.

Japan VCCI Class A compliance statement

この装置は、クラスA情報技術装置です。この装置を家庭環境で使用すると電波妨害を引き起こすことがあります。この場合には使用者が適切な対策を講ずるよう要求されることがあります。 VCCI-A

Japan compliance statement for products which connect to the power mains with rated current less than or equal to 20 A per phase

日本の定格電流が 20A/相 以下の機器に対する高調波電流規制
高調波電流規格 JIS C 61000-3-2 適合品

China Class A compliance statement

声明
此为A级产品。在生活环境中，该产品可能会造成无线电干扰。在这种情况下，可能需要用户对干扰采取切实可行的措施。

Taiwan Class A compliance statement

警告使用者
此為甲類資訊技術設備，於居住環境中使用時，可能會造成射頻擾動，在此種情況下，使用者會被要求採取某些適當的對策。

Lenovo product service information for Taiwan

台灣 Lenovo 產品服務資訊如下：
荷蘭商聯想股份有限公司台灣分公司
台北市信義區信義路五段七號十九樓之一
服務電話：0800-000-702

Index

9240-8i RAID 5 key
installing 60
removing 61

A

assistance, getting 125
attention notices 1
availability 7

B

backplane
locating connectors 18
basic guidelines 21
bays 6

C

cables
rear connectors 91
caution statements 1
configuration 91
Ethernet controller 109
minimum 121
updating server 95
Configuration Utility program
9240-8i SAS RAID controller 95
connector
cables 91
connector description 12
connectors
rear of the server 12
considerations, password 102
contamination, particulate and gaseous 132
controller
Ethernet, configuring 109
controller, configuring Ethernet 109
CRU
completing the installation 90
completing the replacement 90

D

danger statements 1
data rate, Ethernet 109
devices, handling static-sensitive 22
diagnostic
LEDs 123
programs, messages 122
DIMM
installing 30
problems 113
removing 31
display problems 115

drive bays, internal 32
drives
hot-swap, removing 38
non-hot-swap, removing 47
DVD
drive problems 111
error symptoms 111

E

EasyStartup
using 103
error symptoms
CD-ROM drive, DVD-ROM drive 111
general 112
hard disk drive 112
intermittent 112
keyboard, non-USB 113
memory 113
microprocessor 114
monitor 115
mouse, non-USB 113
optional devices 116
pointing device, non-USB 113
power 117
serial port 118
software 119
USB port 120
Ethernet
controller
configuring 109
controller, troubleshooting 120
high performance modes 109
integrated on system board 109
modes 109
Ethernet card
installing 57
removing 57
Ethernet connector 12
Ethernet controller, configuring 109
event logs 122
exiting, Setup Utility program 101
expansion bays 6

F

features 5
firmware, updating 109
front bezel
removing, reinstalling 25
front fan
installing 79
removing 78
front, controls and indicators 9

G

- gaseous contamination 132
- general problems 112
- getting help 125
- gigabit Ethernet controller, configuring 109
- gloss statement (Germany) 133

H

- hard disk drive
 - problems 112
- hard disk drives
 - hot-swap SAS or SATA, installing 41
 - hot-swap SAS or SATA, removing 38
 - non-hot-swap SAS or SATA, installing 49
 - non-hot-swap SAS or SATA, removing 47
- heat sink and fan assembly
 - installing 75
 - removing 71
- help, getting 125
- hot-swap drives, SAS or SATA
 - removing 38
- hot-swap hard disk drive
 - backplanes 19
- hot-swap hard disk drive, SAS or SATA
 - installing 41

I

- important notices 1
- installation order
 - memory module 29
- installation rules
 - memory module 29
- installing
 - 9240-8i RAID 5 key 60
 - DIMM 30
 - Ethernet card 57
 - front fan 79
 - heat sink and fan assembly 75
 - hot-swap SAS or SATA hard disk drive 41
 - internal drives 32
 - memory module 30
 - microprocessor 87
 - non-hot-swap SAS or SATA hard disk drive 49
 - optical drive 35
 - PCI card 54
 - RAID 5 key 58
 - RAID card 70
 - rear fan 83
 - RMM3 63
 - server cover 91
- integrated functions 7
- intermittent problems 112
- internal drives
 - installing 32
 - removing 32

K

- keyboard problems 113

L

- LEDs
 - rear of the server 12
- LEDs and controls
 - on the front of the server 9
- locating connectors
 - backplane 18
- logs
 - system event message 122

M

- memory module
 - installation order 29
 - installation rules 29
 - installing 30
 - removing 31
- memory modules
 - specifications 6
- memory problems 113
- microprocessor
 - installing 87
 - problems 114
 - removing 86
 - specifications 6
- minimum configuration 121
- modes, Ethernet 109
- monitor problems 115
- mouse problems 113

N

- non-hot-swap drives, SAS or SATA
 - removing 47
- non-hot-swap hard disk drive, SAS or SATA
 - installing 49
- non-hot-swap SAS or SATA hard disk drive
 - installing 49
- note 1
- notes, important 130
- notices 129
- notices and statements 1

O

- optical drive
 - installing 35
 - removing 33
- optional device problems 116
- optional optical drive
 - specifications 6

P

- particulate contamination 132

- parts replacement, completing 90
- password
 - considerations 102
 - setting, changing, deleting 102
- PCI card
 - installing 54
 - removing 55
- power
 - problems 117, 120
- power cord connector 12
- power supply 6
- problems
 - CD-ROM, DVD-ROM drive 111
 - DIMM 113
 - Ethernet controller 120
 - general 112
 - hard disk drive 112
 - intermittent 112
 - memory 113
 - microprocessor 114
 - monitor 115
 - mouse 113
 - optional devices 116
 - power 117, 120
 - serial port 118
 - software 119
 - undetermined 121
 - USB port 120

R

- RAID 5 key
 - installing 58
 - removing 59
- RAID card
 - installing 70
 - removing 69
- RAS features 7
- rear fan
 - installing 83
 - removing 82
- rear view 12
- related documentation 2
- reliability 7
- removing
 - 9240-8i RAID 5 key 61
 - DIMM 31
 - Ethernet card 57
 - front fan 78
 - heat sink and fan assembly 71
 - hot-swap hard disk drive 38
 - hot-swap SAS or SATA hard disk drives 38
 - internal drives 32
 - memory module 31
 - microprocessor 86
 - non-hot-swap hard disk drive 47
 - non-hot-swap SAS or SATA hard disk drives 47
 - optical drive 33
 - PCI card 55
 - RAID 5 key 59

- RAID card 69
- rear fan 82
- RMM3 67
- server cover 23
- removing, reinstalling
 - front bezel 25
- replacing
 - system board battery 89
- RMM3
 - installing 63
 - removing 67

S

- SAS or SATA hot-swap hard disk drive
 - installing 41
- SAS or SATA hot-swap hard disk drives
 - removing 38
- SAS or SATA non-hot-swap hard disk drives
 - removing 47
- serial
 - port problems 118
- serial port 12
- server
 - turn off 92
 - turn on 91
- server components
 - locating parts 14
- server configuration, updating 95
- server cover
 - installing 91
 - removing 23
- server cover, reinstalling 90
- serviceability 7
- Setup Utility program
 - starting 95
 - using 95
- Setup Utility program, exiting 101
- size 7
- software problems 119
- specifications 5
- starting
 - Setup Utility program 95
- statements and notices 1
- static-sensitive devices, handling 22
- support, Web site 125
- system
 - event log 122
- system board
 - connectors 15
 - diagnostic LEDs 16
 - jumper blocks 17
 - locating parts 15
 - locations 15
- system board battery
 - replacing 89
- system fans 6
- system reliability guidelines 22
- system-event log 122

T

- the POST
 - event log 122
- ThinkServer Documentation DVD 2
- ThinkServer Remote Management Module 3 63
- ThinkServer Web address 1
- trademarks 130
- troubleshooting tables 111
- turn off
 - server 92
- turn on
 - server 91
- TÜV gloss statement 133

U

- undetermined problems 121
- Universal Serial Bus (USB) problems 120
- updating
 - server configuration 95
- updating firmware 109
- updating the server configuration 91
- USB
 - port problems 120
- USB connector 13
- using
 - EasyStartup 103
 - passwords 101
 - Setup Utility program 95

V

- VGA monitor connector 13
- video
 - problems 115
- video controller, integrated
 - specifications 6

W

- Web site
 - compatible options 29
 - Lenovo support 21
 - publication ordering 125
 - support 125
- working inside the server with the power on 23

lenovo[®]