

ASUS[®]

TS700-E7 / RS8

Pedestal/5U Rackmount Server

User Manual



E7331
First Edition
May 2012

Copyright © 2012 ASUSTeK COMPUTER INC. All Rights Reserved.

No part of this manual, including the products and software described in it, may be reproduced, transmitted, transcribed, stored in a retrieval system, or translated into any language in any form or by any means, except documentation kept by the purchaser for backup purposes, without the express written permission of ASUSTeK COMPUTER INC. ("ASUS").

Product warranty or service will not be extended if: (1) the product is repaired, modified or altered, unless such repair, modification of alteration is authorized in writing by ASUS; or (2) the serial number of the product is defaced or missing.

ASUS PROVIDES THIS MANUAL "AS IS" WITHOUT WARRANTY OF ANY KIND, EITHER EXPRESS OR IMPLIED, INCLUDING BUT NOT LIMITED TO THE IMPLIED WARRANTIES OR CONDITIONS OF MERCHANTABILITY OR FITNESS FOR A PARTICULAR PURPOSE. IN NO EVENT SHALL ASUS, ITS DIRECTORS, OFFICERS, EMPLOYEES OR AGENTS BE LIABLE FOR ANY INDIRECT, SPECIAL, INCIDENTAL, OR CONSEQUENTIAL DAMAGES (INCLUDING DAMAGES FOR LOSS OF PROFITS, LOSS OF BUSINESS, LOSS OF USE OR DATA, INTERRUPTION OF BUSINESS AND THE LIKE), EVEN IF ASUS HAS BEEN ADVISED OF THE POSSIBILITY OF SUCH DAMAGES ARISING FROM ANY DEFECT OR ERROR IN THIS MANUAL OR PRODUCT.

SPECIFICATIONS AND INFORMATION CONTAINED IN THIS MANUAL ARE FURNISHED FOR INFORMATIONAL USE ONLY, AND ARE SUBJECT TO CHANGE AT ANY TIME WITHOUT NOTICE, AND SHOULD NOT BE CONSTRUED AS A COMMITMENT BY ASUS. ASUS ASSUMES NO RESPONSIBILITY OR LIABILITY FOR ANY ERRORS OR INACCURACIES THAT MAY APPEAR IN THIS MANUAL, INCLUDING THE PRODUCTS AND SOFTWARE DESCRIBED IN IT.

Products and corporate names appearing in this manual may or may not be registered trademarks or copyrights of their respective companies, and are used only for identification or explanation and to the owners' benefit, without intent to infringe.

Contents

Safety information.....	vii
About this guide.....	viii
TS700-E7/RS8 specifications summary	x
Chapter 1: Product introduction	1-1
1.1 Package contents.....	1-1
1.2 Serial number label.....	1-2
1.3 Front panel features.....	1-3
1.4 Rear panel features.....	1-4
1.5 Internal features.....	1-5
1.6 LED information.....	1-6
1.6.1 Front panel LEDs.....	1-6
1.6.2 Rear panel LEDs.....	1-7
Chapter 2: Hardware setup	2-1
2.1 Chassis cover.....	2-1
2.1.1 Removing the side cover.....	2-1
2.1.2 Reinstalling the side cover	2-2
2.2 Central Processing Unit (CPU)	2-3
2.2.1 Installing the CPU	2-3
2.2.2 Installing the CPU heatsink and fan connector	2-8
2.3 System memory	2-9
2.3.1 Overview	2-9
2.3.2 Memory Configurations.....	2-10
2.3.3 Installing a DIMM on a single clip DIMM socket.....	2-12
2.4 Front panel assembly	2-13
2.4.1 Removing the front panel assembly.....	2-13
2.4.2 Reinstalling the front panel assembly	2-14
2.5 5.25-inch drives.....	2-14
2.6 SATA/SAS hard disk drives.....	2-15
2.6.1 Installing the HDD module cage.....	2-15
2.6.2 Removing the HDD module cage.....	2-16
2.6.3 Installing a hot-swap SATA/SAS hard disk drive.....	2-17
2.6.4 Removing and reinstalling the backplane	2-19
2.7 Expansion cards	2-20
2.7.1 Installing an expansion card.....	2-20
2.7.2 Installing an ASUS PIKE RAID card.....	2-21
2.7.3 Installing ASMB6 management board.....	2-22
2.7.5 Configuring an expansion card	2-23

2.8	Cable connections	2-24
2.8.1	Motherboard connections.....	2-24
2.8.2	SATA/SAS backplane connections	2-25
2.9	Removable components	2-27
2.9.1	System fan	2-27
2.9.2	Chassis footpads.....	2-29
2.9.3	Redundant power supply module.....	2-29
2.9.4	Fan Duct.....	2-31
Chapter 3:	Installation options	3-1
3.1	Preparing the system for rack mounting	3-1
	Removing the footpads	3-1
	Removing the top cover	3-1
3.2	Attaching the inner rail to the server	3-2
3.3	Attaching the rails to the rack	3-2
3.4	Mounting the server to the rack	3-3
Chapter 4:	Motherboard info	4-1
4.1	Motherboard layout	4-1
4.2	Jumpers	4-3
4.3	Internal connectors	4-7
Chapter 5:	BIOS setup	5-1
5.1	Managing and updating your BIOS	5-1
5.1.1	ASUS CrashFree BIOS 3.....	5-1
5.1.2	ASUS EZ Flash 2.....	5-3
5.1.3	BUPDATER.....	5-4
5.2	BIOS setup program	5-6
5.2.1	BIOS menu screen.....	5-7
5.2.2	Menu bar	5-7
5.2.3	Menu items.....	5-8
5.2.4	Submenu items	5-8
5.2.5	Navigation keys.....	5-8
5.2.6	General help.....	5-8
5.2.7	Configuration fields	5-8
5.2.8	Pop-up window.....	5-8
5.2.9	Scroll bar	5-8
5.3	Main menu	5-9
5.3.1	System Date [Day xx/xx/xxxx].....	5-9
5.3.2	System Time [xx:xx:xx].....	5-9

5.4	Advanced menu	5-10
5.4.1	CPU Configuration	5-10
5.4.2	CPU Power Management Configuration	5-13
5.4.3	Chipset Configuration.....	5-15
5.4.4	PCH SATA Configuration	5-21
5.4.5	PCH SCU Configuration.....	5-23
5.4.6	PCI Subsystem Settings	5-23
5.4.7	Onboard LAN Configuration.....	5-27
5.4.8	Intel TXT(LT-SX) Configuration	5-28
5.4.9	USB Configuration	5-29
5.4.10	Trusted Computing.....	5-30
5.4.11	ACPI Settings.....	5-31
5.4.12	WHEA Configuration	5-32
5.4.13	APM setting.....	5-32
5.4.14	Serial Port Console Redirection	5-33
5.4.15	ME Subsystem	5-36
5.4.16	Legacy Devices Configuration	5-36
5.4.17	Runtime Error Logging	5-37
5.5	Server Mgmt menu.....	5-38
5.5.1	System Event Log.....	5-39
5.5.2	BMC network configuration.....	5-40
5.6	Event Logs menu	5-41
5.6.1	Change Smbios Event Log Settings	5-41
5.7	Boot menu	5-43
5.8	Monitor menu	5-45
5.9	Security menu	5-46
5.10	Tool menu	5-48
	ASUS EZ Flash 2 Utility	5-48
5.11	Exit menu	5-49
Chapter 6:	RAID configuration	6-1
6.1	Setting up RAID.....	6-1
6.1.2	Installing hard disk drives.....	6-2
6.1.3	Setting the RAID item in BIOS	6-2
6.1.4	RAID configuration utilities	6-3
6.2	LSI Software RAID Configuration Utility	6-3
6.2.1	Creating a RAID set	6-5
6.2.2	Adding or viewing a RAID configuration.....	6-10
6.2.3	Initializing the virtual drives	6-12
6.2.4	Rebuilding failed drives.....	6-16

6.2.5	Checking the drives for data consistency.....	6-18
6.2.6	Deleting a RAID configuration.....	6-21
6.2.7	Selecting the boot drive from a RAID set.....	6-22
6.2.8	Enabling WriteCache	6-23
6.3	Intel® Rapid Storage Technology enterprise SCU/SATA	
	Option ROM Utility	6-24
6.3.1	Creating a RAID set.....	6-26
6.3.2	Creating a Recovery set.....	6-27
6.3.3	Deleting a RAID set.....	6-29
6.3.4	Resetting disks to Non-RAID	6-30
6.3.5	Exiting the Intel® Rapid Storage Technology utility.....	6-31
6.3.6	Rebuilding the RAID.....	6-31
6.3.7	Setting the Boot array in the BIOS Setup Utility.....	6-33
6.4	Intel® Rapid Storage Technology enterprise Utility (Windows)	6-34
6.4.1	Creating a RAID set.....	6-35
6.4.2	Change Volume Type.....	6-37
6.4.3	Delete volume	6-39
6.4.4	Preferences.....	6-40
Chapter 7:	Driver installation	7-1
7.1	RAID driver installation	7-1
7.1.1	Creating a RAID driver disk.....	7-1
7.1.2	Installing the RAID controller driver.....	7-4
7.2	Intel® chipset device software installation.....	7-15
7.3	Intel® Network Connections Software installation	7-18
7.4	VGA driver installation	7-21
7.5	Intel® C600 Series Chipset SCU SATA RAID Driver.....	7-24
7.6	Microsoft .NET Framework 3.5 SP1.....	7-25
7.7	Intel® Rapid Storage Technology enterprise 3.0 installation	7-26
7.8	Intel® I350 Gigabit Adapters Driver installation	7-29
7.9	Management applications and utilities installation	7-33
7.9.1	Running the support DVD	7-33
7.9.2	Drivers menu.....	7-33
7.9.3	Utilities menu.....	7-34
7.9.4	Make disk menu.....	7-34
7.9.5	Contact information.....	7-34
Appendices		A-1
Notices		A-1
ASUS contact information.....		A-3

Safety information

Electrical safety

- To prevent electrical shock hazard, disconnect the power cable from the electrical outlet before relocating the system.
- When adding or removing devices to or from the system, ensure that the power cables for the devices are unplugged before the signal cables are connected. If possible, disconnect all power cables from the existing system before you add a device.
- Before connecting or removing signal cables from the motherboard, ensure that all power cables are unplugged.
- Seek professional assistance before using an adapter or extension cord. These devices could interrupt the grounding circuit.
- Ensure that your power supply is set to the correct voltage in your area. If you are not sure about the voltage of the electrical outlet you are using, contact your local power company.
- If the power supply is broken, do not try to fix it by yourself. Contact a qualified service technician or your retailer.

Operation safety

- Before installing the motherboard and adding devices on it, carefully read all the manuals that came with the package.
- Before using the product, ensure all cables are correctly connected and the power cables are not damaged. If you detect any damage, contact your dealer immediately.
- To avoid short circuits, keep paper clips, screws, and staples away from connectors, slots, sockets and circuitry.
- Avoid dust, humidity, and temperature extremes. Do not place the product in any area where it may become wet.
- Place the product on a stable surface.
- If you encounter technical problems with the product, contact a qualified service technician or your retailer.

About this guide

This user guide contains the information you need when installing and configuring the motherboard.

How this guide is organized

1. Chapter 1: Product introduction

This chapter describes the general features of the server, including sections on front panel and rear panel specifications.

2. Chapter 2: Hardware setup

This chapter lists the hardware setup procedures that you have to perform when installing or removing system components.

3. Chapter 3: Installation options

This chapter describes how to install optional components into the barebone server.

4. Chapter 4: Motherboard information

This chapter gives information about the motherboard that comes with the server. This chapter includes the motherboard layout, jumper settings, and connector locations.

5. Chapter 5: BIOS information

This chapter tells how to change system settings through the BIOS Setup menus and describes the BIOS parameters.

6. Chapter 6: RAID configuration

This chapter tells how to change system settings through the BIOS Setup menus. Detailed descriptions of the BIOS parameters are also provided.

7. Chapter 7: Driver installation

This chapter provides instructions for installing the necessary drivers for different system components.

Where to find more information

Refer to the following sources for additional information and for product and software updates.

1. ASUS Server Web-based Management (ASWM) user guide

This manual tells how to set up and use the proprietary ASUS server management utility.

2. ASUS websites

The ASUS websites worldwide provide updated information for all ASUS hardware and software products. Refer to the ASUS contact information.

Conventions used in this guide

To ensure that you perform certain tasks properly, take note of the following symbols used throughout this manual.



DANGER/WARNING: Information to prevent injury to yourself when trying to complete a task.



CAUTION: Information to prevent damage to the components when trying to complete a task.



IMPORTANT: Instructions that you **MUST** follow to complete a task.



NOTE: Tips and additional information to help you complete a task.

Typography

Bold text

Indicates a menu or an item to select.

Italics

Used to emphasize a word or a phrase.

<Key>

Keys enclosed in the less-than and greater-than sign means that you must press the enclosed key.

Example: <Enter> means that you must press the Enter or Return key.

<Key1> + <Key2> + <Key3>

If you must press two or more keys simultaneously, the key names are linked with a plus sign (+).

TS700-E7/RS8 specifications summary

CPU		2 x LGA2011 socket for Intel® Xeon® E5-2600 Series processors QPI 6.4 / 7.2 / 8.0 GT/s
Chipset		Intel® C602-A
Memory	Total Slots	16 (4-channel per CPU, 8 DIMMs per CPU)
	Capacity	Maximum up to 512GB (RDIMM)
	Memory Type	DDR3 1066/1333/1600 RDIMM DDR3 1066/1333 UDIMM (ECC/non-ECC) DDR3 1066/1333 LR-DIMM
	Memory Size	2GB, 4GB, 8GB, 16GB* (RDIMM) 2GB, 4GB, 8GB* (UDIMM) 8GB, 16GB, 32GB* (LRDIMM)
Expansion Slots	Total PCI/PCI-X/PCI-E Slots	6
	Slot Type	- Slot 1: PCIe x16 (X16 Gen3 link, Auto switch to X8 link if PCIe2 is occupied, MIO supported, White, from CPU 1) - Slot 2: PCIe x16 (X16 Gen3 link, Auto switch to X8 link if PCIe1 is occupied, White, from CPU 1) - Slot 3: PCIe x16 (X16 Gen3 link, Black, from CPU 2) - Slot 4: PCIe x16 (X16 Gen3 link, White, from CPU 1) - Slot 5: PCIe x16 (X16 Gen3 link, Black, from CPU 2) - Slot 6: PCIe x16 (X8 Gen3 link, Black, from CPU 2)
	Additional Slot	1 x PIKE slot for Storage Enhancement
Storage	SATA Controller	Intel® C602-A: <AHCI> 2 SATA 6Gb/s ports 4 SATA 3Gb/s ports Intel® RSTe (for Windows only) (Support software RAID 0, 1, 10 & 5) LSI® MegaRAID (for Linux/Windows) (Support software RAID 0, 1, 10)

(continued on the next page)

TS700-E7/RS8 specifications summary

Storage	SATA Controller	<SCU> 4 SATA 3Gb/s ports Intel® RSTe (for Windows only) (Support software RAID 0, 1, 10 & 5 for all SATA ports)
	SAS Controller	Optional: ASUS PIKE 2008 8-port SAS 6G RAID card ASUS PIKE 2008/IMR 8-port SAS 6G RAID card ASUS PIKE 2108 8-port SAS 6G HW RAID card
HDD Bays	I = internal A or S = hot-swappable	8 x Hot-swap 3.5" HDD Bays
VGA		Aspeed AST2300 16MB
Onboard I/O		5 x RJ-45 ports (One for ASMB6-iKVM) 4 x USB 2.0 ports (Front * 2, Rear * 2) 1 x Internal A Type USB Port 1 x VGA port 1 x PS/2 keyboard port 1 x PS/2 mouse port
OS Support		Windows® Server 2008 R2 Windows® Server 2008 R2 Enterprise Windows® Server 2008 Enterprise 32/64 bit Window 7 (Ultimate SP1) 32/64-bit RedHat® Enterprise Linux AS5.6/6.0 32/64-bit SuSE® Linux Enterprise Server 11.2 32/64-bit CentOS 5.6 32/64-bit VMWare ESX4.1/ESXi4.1
Anti-virus Software		Optional anti-virus CD Pack
Management Solution	Out of Band Remote Management	Default 1 x ASMB6-iKVM for KVM-over-Internet
	Software	ASWM Enterprise 2.0®
Dimension (HH x WW x DD)		445mm x 217.5mm x 545mm

(continued on the next page)

TS700-E7/RS8 specifications summary

Net Weight Kg (CPU, DRAM & HDD not included)	20 Kg
Power Supply	1+1 Redundant 800W 80PLUS Gold Power Supply (following different configuration by region) or 1+1 Redundant 620W Power Supply (for Taiwan only)
Power Supply Rating Output	800W: 100-127 / 200-240 Vac, 9.9A / 4.79A, 47-63 Hz, Class 1 620W (for Taiwan only): 100-240 Vac, 10A, 50-60 Hz, Class 1
Environment	Operating temperature: 10°C ~ 35°C Non operating temperature: -40°C ~ 70°C Non operating humidity: 20% ~ 90% (Non condensing)



Specifications are subject to change without notice.

Product introduction

1

1.1 Package contents

Model Name	TS700-E7/RS8
Chassis	ASUS T50A Pedestal 5U Rackmount Chassis
Motherboard	ASUS Z9PE-D16 Server Board
Component	1 x 620W (for Taiwan only) or 800W Redundant Power Supply Module 8 x hot-swap HDD trays 2 x SAS/SATA2 Backplane with four data cables 1 x Front I/O Board 4 x System Fans (Front: 3 x 80mm x 38mm; Rear: 1 x 120mm x 38mm)
Accessories	1 x TS700-E7/RS8 User's Guide 1 x ASUS ASWM Enterprise User's Guide 1 x TS700-E7/RS8 Support CD (including ASWM*) 1 x Bag of Screws 1 x ASMB6 Series DVD 1 x ASUS ASWM Enterprise* User's Guide 1 x ASMB6 User's Guide 2 x AC Power Cable
Optional Items	2 CPU Heatsinks DVD-ROM / DVD-RW 620W (for Taiwan only) or 800W Redundant Power Supply Module ASUS TS700-E7/RS8 Rackmount Rail Kit ASUS PIKE RAID Card

*ASUS System Web-based Management

If any of the above items is damaged or missing, contact your retailer.



1.2 Serial number label

For faster and quicker troubleshooting solutions from the ASUS Technical Support team, provide the product's serial number containing 12 characters such as xxS0xxxxxxx as shown in the figure below.

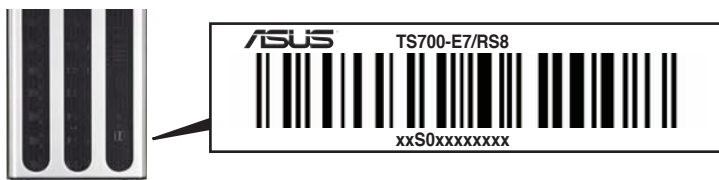

1.3 Front panel features

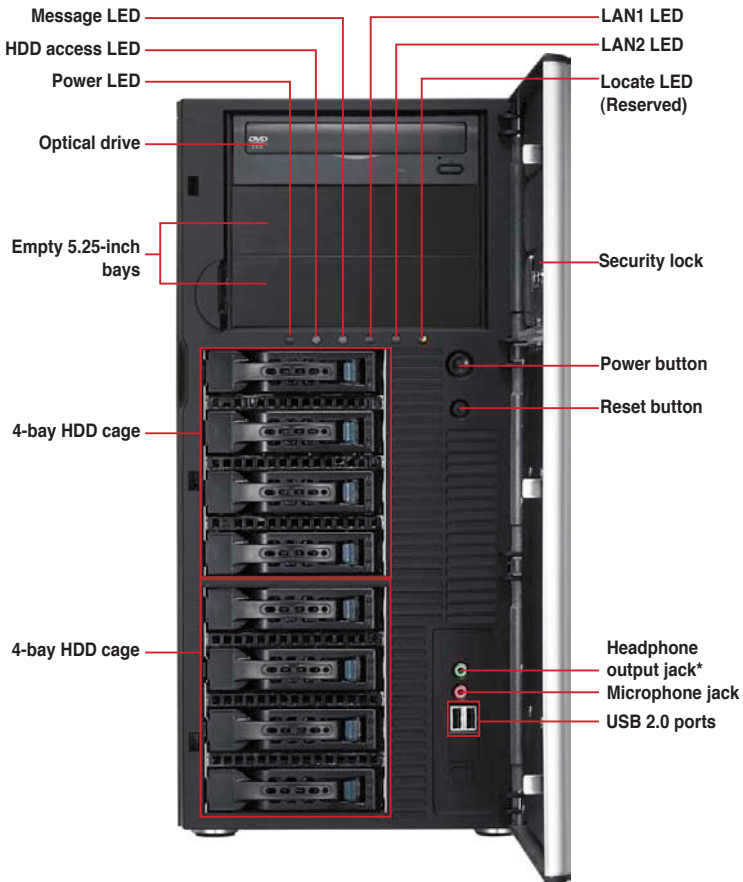

*The audio jacks function only with an optional MIO audio card.



Refer to section 1.6.1 Front panel LEDs for the LED descriptions.

1.4 Rear panel features

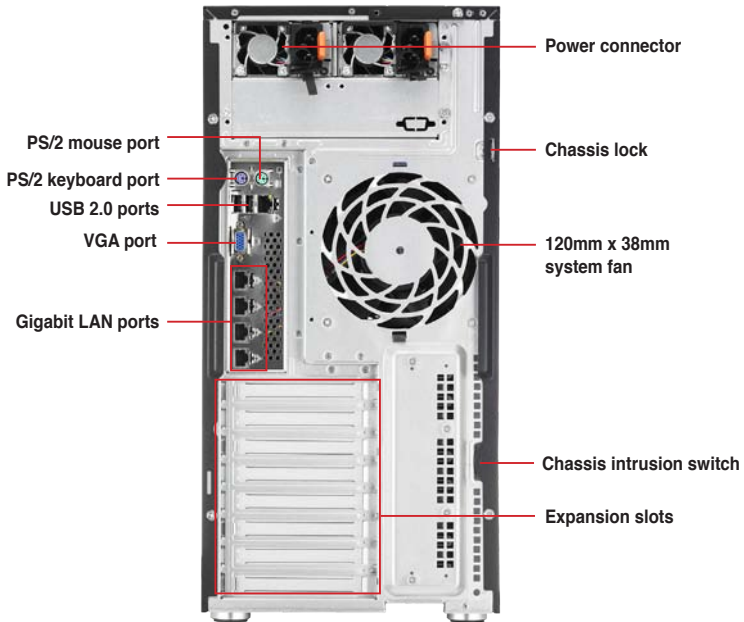

1.5 Internal features

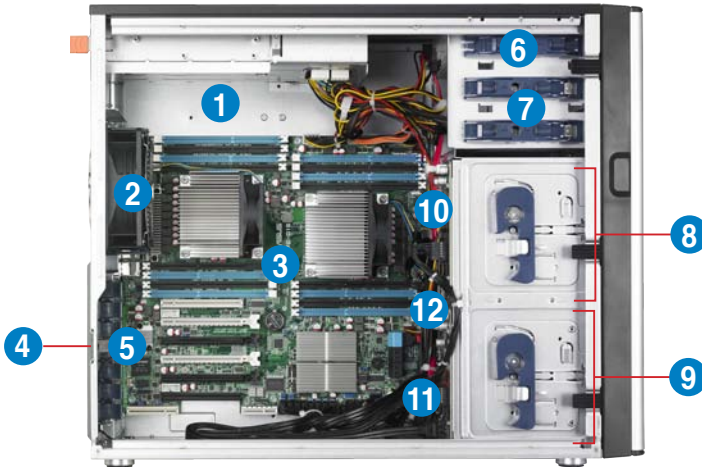

1. 620W (for Taiwan only) or 800w Redundant Power Supply (the second set is an optional item)
2. 120mm x 38mm system fan
3. ASUS Z9PE-D16 Server Board
4. Chassis intrusion switch
5. Expansion card locks
6. Optical drive
7. 2 x 5.25-inch drive bays
8. 4-bay HDD module (first set)
9. 4-bay HDD module (second set)
10. SATA/SAS backplane board (first set, hidden)
11. SATA/SAS backplane board (second set, hidden)
12. 80mm x 38mm system fan



Turn off the system power and detach the power supply before removing or replacing any system component.







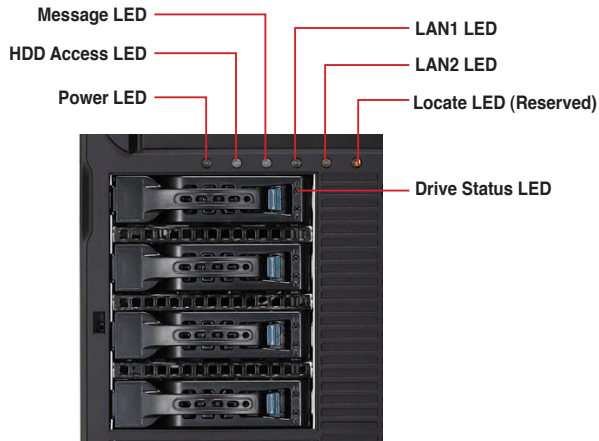

The barebone server does not include a floppy disk drive and an optical disc drive. Connect a USB floppy disk drive or a USB ODD to any of the USB ports on the front or rear panel if you need to use a floppy disk or a optical disc.

1.6 LED information

1.6.1 Front panel LEDs



LED	Icon	Display status	Description
Power LED		ON	System power ON
HDD Access LED		OFF	No activity
		Blinking	Read/write data into the HDD.
Message LED		OFF	System is normal; no incoming event
		Lighting up	A hardware temperature overheat is detected. Use ASWM to check the abnormal status.
Drive status LED		Green	Bridge board connected to backplane Installed HDD is in good condition
		Red	HDD failure
		Green/Red Blinking	HDD rebuilding using the RAID card
LAN LEDs		OFF	
		Blinking	LAN accessing
		ON	
Locate LED		ON	Locates a specific server



The Power, HDD Access, LAN and Message LEDs are visible even if the system front bezel is closed.

1.6.2 Rear panel LEDs

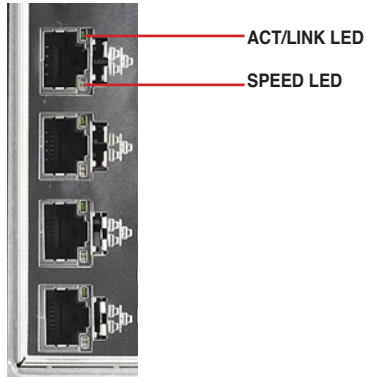

ACT/LINK LED		SPEED LED	
Status	Description	Status	Description
OFF	No link	OFF	10 Mbps connection
GREEN	Linked	ORANGE	100 Mbps connection
BLINKING	Data activity	GREEN	1 Gbps connection

Hardware setup

2

2.1 Chassis cover

2.1.1 Removing the side cover



- Ensure that you unplug the power cord before removing the side cover.
- Take extra care when removing the side cover. Keep your fingers from components inside the chassis that can cause injury, such as the CPU fan, rear fan, and other sharp-edged parts.

To remove the side cover:

1. Remove the two screws that secure the side cover.

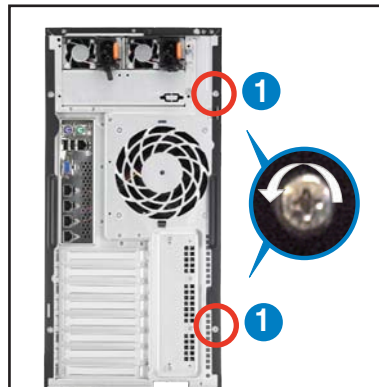

2. Slide the side cover for about half an inch toward the rear until it is disengaged from the chassis.
3. Carefully lift the side cover and set it aside.

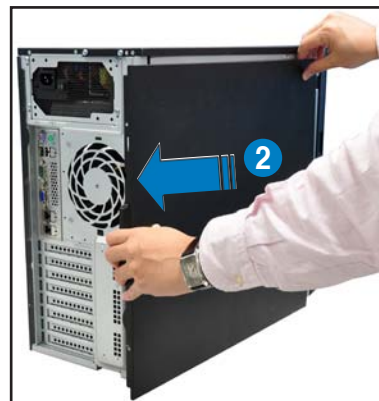

2.1.2 Reinstalling the side cover

To reinstall the side cover:

1. Match and insert the lower sliding edge of the side cover to the corresponding chassis edge.



2. Slide the side cover toward the front panel until it snaps in place.
3. Drive in the two screws you removed earlier to secure the side cover.



2.2 Central Processing Unit (CPU)

The motherboard comes with a surface mount LGA2011 socket designed for the Intel® Xeon E5-2600 family processor.



- Upon purchase of the motherboard, ensure that the PnP cap is on the socket and the socket contacts are not bent. Contact your retailer immediately if the PnP cap is missing, or if you see any damage to the PnP cap/socket contacts/motherboard components. ASUS shoulders the repair cost only if the damage is shipment/transit-related.
- Keep the cap after installing the motherboard. ASUS will process Return Merchandise Authorization (RMA) requests only if the motherboard comes with the cap on the LGA 2011 Socket.
- The product warranty does not cover damage to the socket contacts resulting from incorrect CPU installation/removal, or misplacement/loss/incorrect removal of the PnP cap.

2.2.1 Installing the CPU

To install a CPU:

1. Locate the CPU socket on the motherboard.

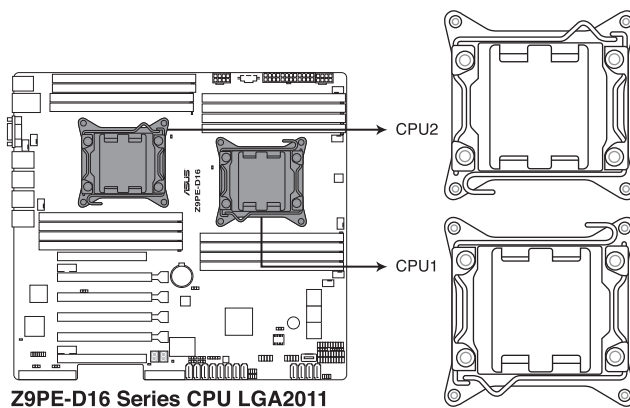

Before installing the CPU, ensure that the socket box is facing towards you and the load lever is on your left.

2. Press the left load lever with your thumb (A), then move it to the left (B) until it is released from the retention tab.



To prevent damage to the socket pins, do not remove the PnP cap unless you are installing a CPU.

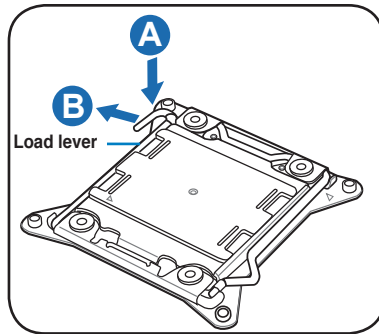

3. Slightly lift the load lever in the direction of the arrow.

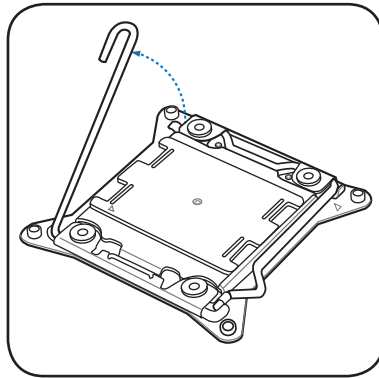

4. Press the right load lever with your thumb (C), then move it to the right (D) until it is released from the retention tab. Lift the load lever in the direction of the arrow (E).

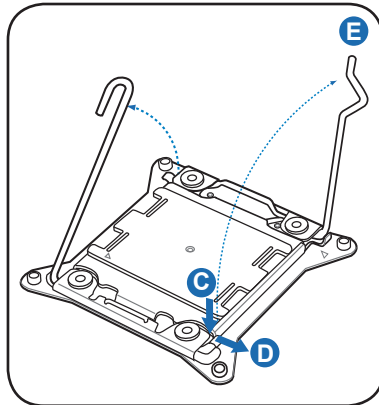

5. Push the left load lever (F) to lift the load plate (G).

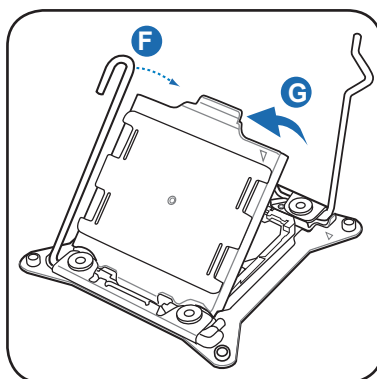

6. Position the CPU over the socket, ensuring that the triangle mark is on the top-right corner of the socket.

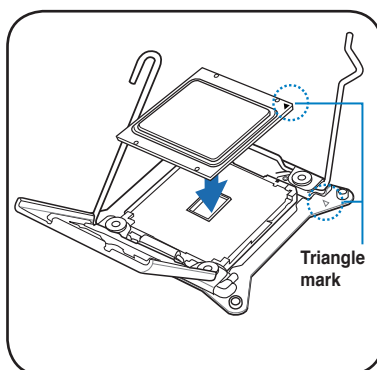

The CPU fits in only one correct orientation. DO NOT force the CPU into the socket to prevent bending the connectors on the socket and damaging the CPU!

7. Remove the PnP cap (H) from the CPU socket and close the load plate (I).

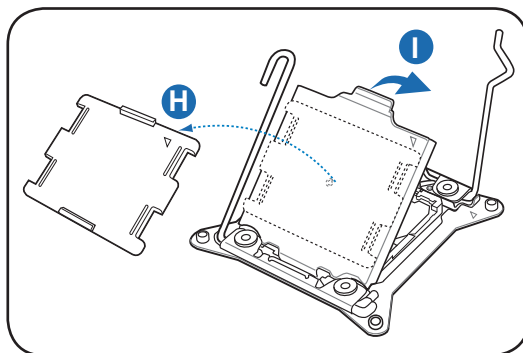

8. Push down the right load lever (J), ensuring that the edge of the load plate is fixed by the lever (K).

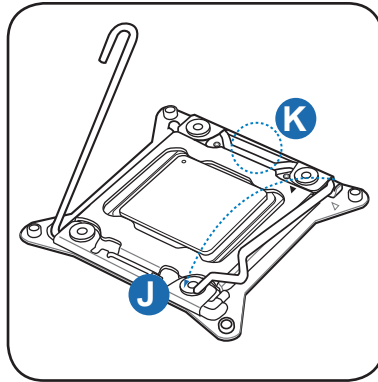

9. Insert the right load lever under the retention tab.

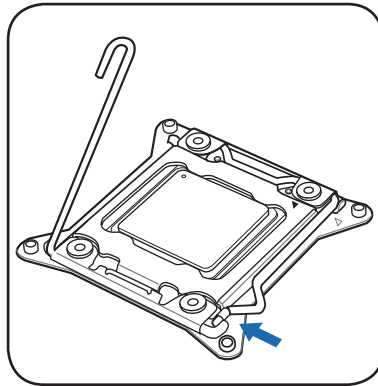

10. Push down the left load lever (L), and then insert the lever under the retention tab (M).

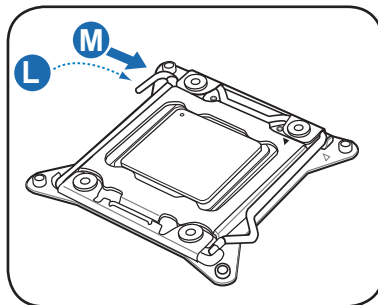

- Apply some Thermal Interface Material to the exposed area of the CPU that the heatsink will be in contact with, ensuring that it is spread in an even thin layer.



Some heatsinks come with pre-applied thermal paste. If so, skip this step.

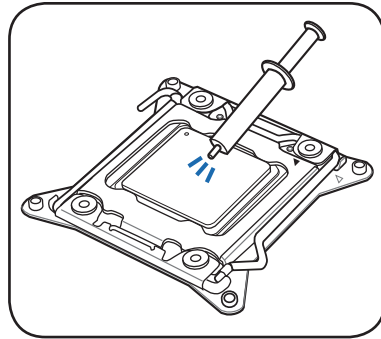

The Thermal Interface Material is toxic and inedible. DO NOT eat it. If it gets into your eyes or touches your skin, wash it off immediately, and seek professional medical help if irritation occurs.

- Connect the CPU fan cable to the connector on the motherboard labeled CPU_FAN1 / CPU_FAN2.

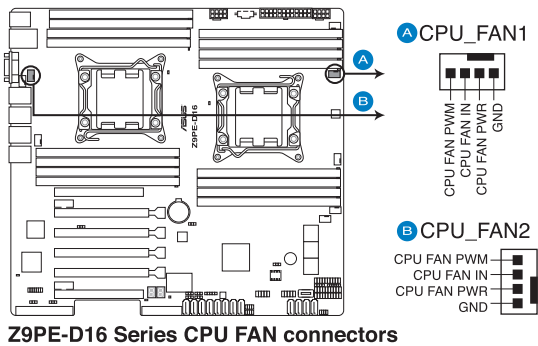

DO NOT forget to connect the CPU fan connector! Hardware monitoring errors can occur if you fail to plug this connector.

2.2.2 Installing the CPU heatsink and fan connector

To install the CPU heatsink and fan connector:

1. Place the CPU heatsink and fan on top of the installed CPU, ensuring that the four screws match the holes on the support plate, and the arrow on the fan faces the rear panel of the server chassis.



2. Twist each of the four screws with a Philips (cross) screwdriver just enough to attach the CPU heatsink and fan to the motherboard. When the four screws are attached, tighten them one by one to completely secure the CPU heatsink and fan.



3. Connect the CPU heatsink and fan cable to the connector on the motherboard.



Do not forget to connect the CPU heatsink and fan connector. Hardware monitoring errors can occur if you fail to plug this connector.

2.3 System memory

2.3.1 Overview

The motherboard comes with eight (per CPU) Double Data Rate 3 (DDR3) Dual Inline Memory Modules (DIMM) sockets.

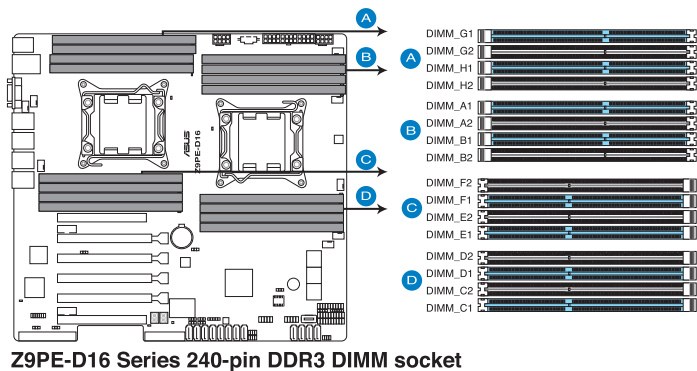

2.3.2 Memory Configurations

You may install 2GB, 4GB, 8GB, and 16GB RDIMMs or 2GB, 4GB and 8GB* with ECC/Non-ECC UDIMMs or 8GB, 16GB and 32GB* LR-DIMMs into the DIMM sockets using the memory configurations in this section.



-
- Always install DIMMs with the same CAS latency. For optimum compatibility, we recommend that you obtain memory modules from the same vendor. Refer to the Qualified Vendors List on the ASUS web site.
 - **You may install varying memory sizes in Channel A, Channel B and Channel C.** The system maps the total size of the lower-sized channel for the dual-channel or triple-channel configuration. Any excess memory from the higher-sized channel is then mapped for single-channel operation.
 - **Due to the memory address limitation on 32-bit Windows OS, when you install 4GB or more memory on the motherboard, the actual usable memory for the OS can be about 3GB or less.** For effective use of memory, we recommend that you do any of the following:
 - Use a maximum of 3GB system memory if you are using a 32-bit Windows OS.
 - **Install a 64-bit Windows OS when you want to install 4GB or more on the motherboard.** For more details, refer to the Microsoft® support site at <http://support.microsoft.com/kb/929605/en-us>.
 - **This motherboard does not support DIMMs made up of 256 Mb (32MB) chips or less (Memory chip capacity counts in Megabit, 8 Megabit/Mb = 1 Megabyte/MB).**
-

Memory population table

CPU1 Configuration								
	A2	A1	B2	B1	C2	C1	D2	D1
1 DIMM		✓						
2 DIMMs		✓		✓				
4 DIMMs		✓		✓		✓		✓
8 DIMMs	✓	✓	✓	✓	✓	✓	✓	✓

CPU1 + CPU2 Configuration																
	A2	A1	B2	B1	C2	C1	D2	D1	E2	E1	F2	F1	G2	G1	H2	H1
1 DIMM		✓														
2 DIMMs		✓								✓						
4 DIMMs		✓		✓						✓		✓				
8 DIMMs		✓		✓		✓		✓		✓		✓		✓		✓
12 DIMMs	✓	✓	✓	✓		✓		✓	✓	✓	✓	✓		✓		✓
16 DIMMs	✓	✓	✓	✓	✓	✓	✓	✓	✓	✓	✓	✓	✓	✓	✓	✓

2.3.3 Installing a DIMM on a single clip DIMM socket

1. Unlock a DIMM socket by pressing the retaining clip outward.
2. Align a DIMM on the socket such that the notch on the DIMM matches the DIMM slot key on the socket.

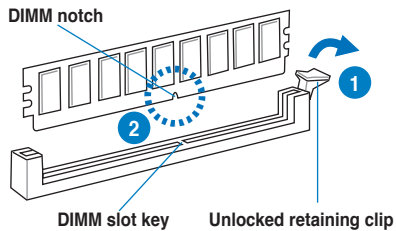

A DIMM is keyed with a notch so that it fits in only one direction. **DO NOT** force a DIMM into a socket in the wrong direction to avoid damaging the DIMM.

3. Hold the DIMM by both of its ends, then insert the DIMM vertically into the socket. Apply force to both ends of the DIMM simultaneously until the retaining clip snaps back into place, and the DIMM cannot be pushed in any further to ensure proper sitting of the DIMM.

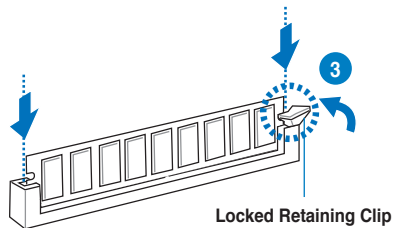

Always insert the DIMM into the socket **VERTICALLY** to prevent DIMM notch damage.



To install two or more DIMMs, refer to the user guide bundled in the motherboard package.

Refer to the user guide for qualified vendor lists of the memory modules.

Removing a DIMM from a single clip DIMM socket

1. Press the retaining clip outward to unlock the DIMM.
2. Remove the DIMM from the socket.

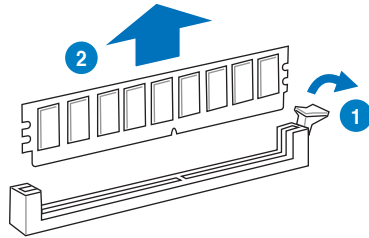

Support the DIMM lightly with your fingers when pressing the retaining clips. The DIMM might get damaged when it flips out with extra force.

2.4 Front panel assembly

Before you can install a 5.25-inch drive, you should first remove the front panel assembly (front bezel and front panel cover).

2.4.1 Removing the front panel assembly

To remove the front panel assembly

1. Locate the three hooked tabs on the chassis side rail.
2. Shift the hooked tabs and take off the front bezel.

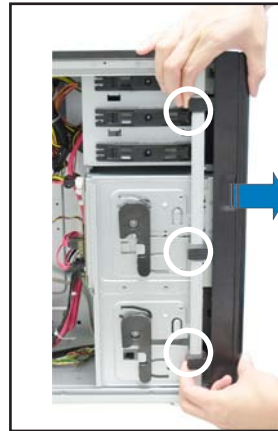

2.4.2 Reinstalling the front panel assembly

To reinstall the front panel assembly:

1. Hook the other side of the front panel assembly to the chassis.
2. Swing the front panel assembly and snap it back into place.



2.5 5.25-inch drives



Ensure to unplug the power cable before installing or removing any system components. Failure to do so may cause damage to the motherboard and other system components!

The system comes with three 5.25-inch drive bays located on the upper front part of the chassis. An optical drive that comes standard/optional with the system package occupies the uppermost bay (labeled 1). The lower bays (labeled 2 and 3) are available for additional 5.25-inch optical, zip, or floppy disk drives.

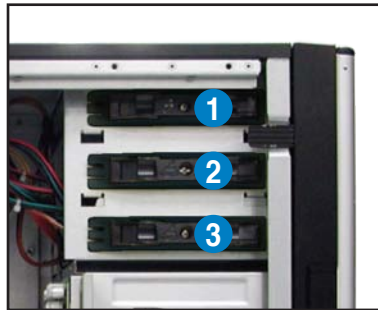

You must remove the front panel assembly before installing a 5.25-inch drive.

Installing a 5.25-inch drive

1. Unscrew and remove the metal cover of the bay where you want to install the 5.25-inch drive, and take off the plastic cover on the front bezel at the same position.
2. Insert the drive into the bay and slide the bay lock to the right until it clicks in place.
3. Connect the SATA cable to the SATA connector on the back of the drive.
4. Connect a power plug from the power supply to the power connector on the back of the drive.

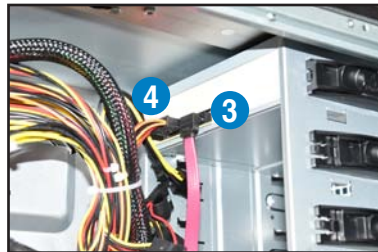

2.6 SATA/SAS hard disk drives

The hard disk drive module cage on the front panel, including externally removable trays for mounting either SATA or SAS hard disk drives, allows you to access the drive trays by simply opening the front bezel.



An HDD module cage comes with a SATA or SAS backplane. Take note of the type of HDD module cage you purchase before buying hard disks.

2.6.1 Installing the HDD module cage

1. Examine the chassis and ensure the bay space is free of wires and other obstructions.
2. Level the HDD module cage latch counterclockwise.
3. Insert the HDD module cage into the bay.



4. When the HDD module cage is completely inserted, the cage latch will be pushed back clockwise.



5. Lock the cage latch properly.
6. Connect the appropriate cables to the SATA/SAS backplane on the HDD module cage.



2.6.2 Removing the HDD module cage

1. Disconnect all the cables from the SATA/SAS backplane on the HDD module cage.
2. Level the HDD module cage latch counterclockwise. The HDD module cage will be pushed out of the chassis.



3. Completely pull out the HDD module cage.



2.6.3 Installing a hot-swap SATA/SAS hard disk drive

1. Release a drive tray by pushing the spring lock to the right, and then pulling the tray lever outward. The drive tray ejects slightly after you pull out the lever.



2. Firmly hold the tray lever and pull the drive tray out of the bay.



3. Take note of the drive tray holes. Each side has three holes to fit different types of hard disk drives. Use two screws on each side to secure the hard disk drive.



4. Place a SATAII/SAS hard disk drive on the tray, and then secure it with four screws.



5. Carefully insert the drive tray and push it all the way to the depth of the bay until just a small fraction of the tray edge protrudes.



When installed, the SATAII/SAS connector on the drive connects to the SATAII/SAS interface on the backplane.

6. Push the tray lever until it clicks, and secures the drive tray in place. The drive tray is correctly placed when its front edge aligns with the bay edge.
7. Repeat steps 1 to 6 if you wish to install a second SATAII/SAS drive.

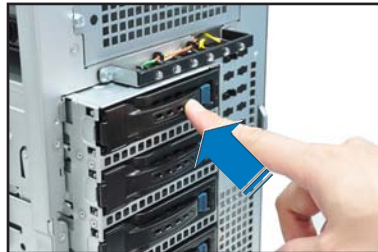

2.6.4 Removing and reinstalling the backplane



DO NOT remove the backplane unless necessary!

1. Remove all hot-swap HDD trays from the chassis.
2. Disconnect all cables from the SATA/SAS backplane.
3. Loosen the four screws on the backplane.

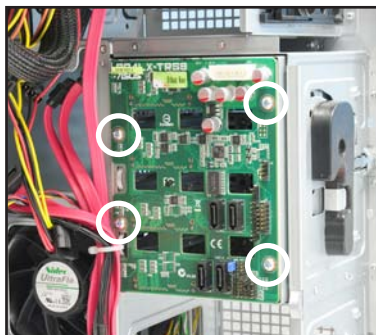

4. Firmly hold the backplane, lift it up and remove it from the module.
5. Follow the previous instructions in reverse to reinstall the backplane



2.7 Expansion cards

The system is designed with an expansion card lock on the rear panel for you to install or remove an expansion card in less steps.



Ensure to unplug the power cord before installing or removing expansion cards. Failure to do so may cause severe damage to the motherboard and other system components!

2.7.1 Installing an expansion card

1. Before installing the expansion card, read the documentation that came with it and make the necessary hardware settings for the card.
2. Lay the system on its side on a flat, stable surface.

3. Push down the expansion card lock latch (step a) and lift up the expansion card lock (step b), as shown in the right figure.

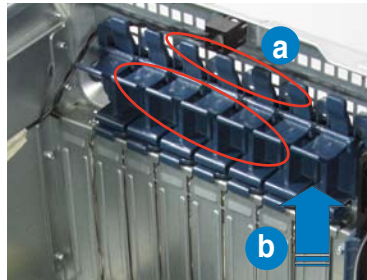

4. Remove the metal slot cover opposite the slot where you wish to install an expansion card.



5. Align the card's golden fingers with the slot, and then press firmly until the card is completely seated on the slot.

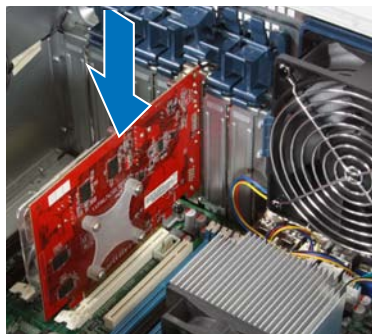

6. Push the expansion card lock back to its original position. A light click indicates that the card is locked in place.



When installing a graphics card on a PCIe slot, the PCIe slot right beside it does not function.

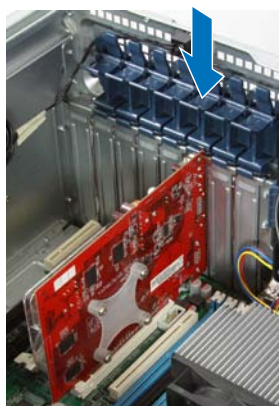

2.7.2 Installing an ASUS PIKE RAID card

Follow the steps below to install an optional ASUS PIKE RAID card on your motherboard.

1. Locate the PIKE RAID card slot on the motherboard.



2. Align the golden fingers of the PIKE RAID card with the PIKE RAID card slot.

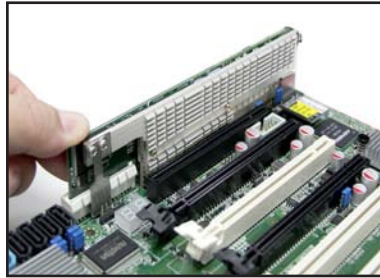

3. Insert the PIKE RAID card into the PIKE RAID card slot. Ensure it is completely seated on the PIKE RAID card slot.

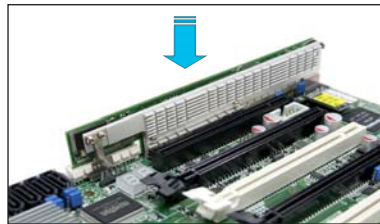

2.7.3 Installing ASMB6 management board

Follow the steps below to install an optional ASMB6 management board on your motherboard.

1. Locate the ASMB6 header on the motherboard.

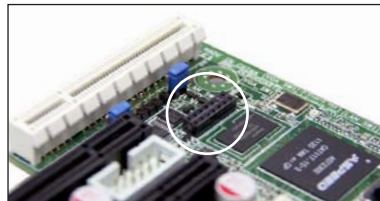

2. Orient and press the ASMB6 management card in place.

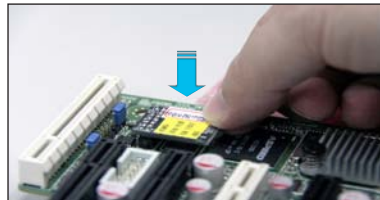

2.7.5 Configuring an expansion card

After installing the expansion card, configure it by adjusting the software settings.

1. Turn on the system and change the necessary BIOS settings, if any. See Chapter 5 for information on BIOS setup.
2. Assign an IRQ to the card. Refer to the following tables.
3. Install the software drivers for the expansion card.

Standard Interrupt assignments

IRQ	Priority	Standard function
0	1	System Timer
1	2	Keyboard Controller
2	-	Programmable Interrupt
3*	11	Communications Port (COM2)
4*	12	Communications Port (COM1)
5*	13	--
6	14	Floppy Disk Controller
7*	15	--
8	3	System CMOS/Real Time Clock
9*	4	ACPI Mode when used
10*	5	IRQ Holder for PCI Steering
11*	6	IRQ Holder for PCI Steering
12*	7	PS/2 Compatible Mouse Port
13	8	Numeric Data Processor
14*	9	Primary IDE Channel
15*	10	Secondary IDE Channel

* These IRQs are usually available for ISA or PCI devices.

2.8 Cable connections



- The bundled system cables are pre-connected before shipment. You do not need to disconnect these cables unless you will remove pre-installed components to install additional devices.
- Refer to Chapter 4 for detailed information on the connectors.

2.8.1 Motherboard connections

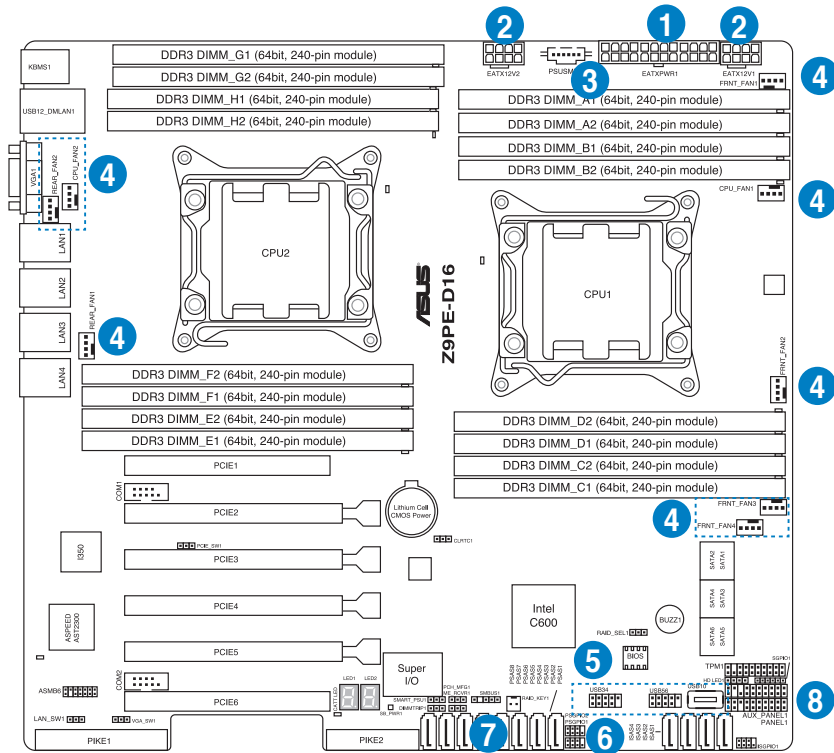

Standard cables connected to the motherboard

1. 24-pin EATX power connector (from power supply to motherboard)
2. 8-pin 12V power connector (from power supply to motherboard)
3. Power supply SMBus connector (from power supply to motherboard)
4. System fan connectors (from system fan to motherboard)
5. USB connectors (from motherboard to front I/O board)
6. Serial General Purpose Input/Output connectors
7. SAS connectors (for ASUS PIKE only; from motherboard to SATA/SAS backplane)
8. Auxiliary panel connector (from motherboard to front I/O board)

2.8.2 SATA/SAS backplane connections

A SATA/SAS backplane comes pre-installed in the TS700-E7/RS8. The SATA/SAS backplane has four 22-pin SATA/SAS connectors to support Serial ATA hard disk drives and SAS hard disk drives. The backplane design incorporates a hot swap feature to allow easy connection or removal of SATA/SAS hard disks. The LEDs on the backplane connect to the front panel LEDs to indicate HDD status. See section 1.6.1 LED information for details.

Front side

The front side of the SATA/SAS backplane faces the front panel when installed. This side includes four SATA/SAS connectors for the hot swap drive trays.

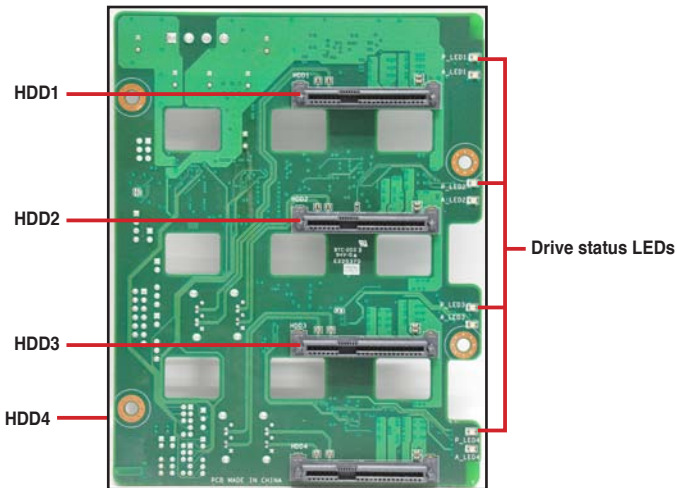

Each SATA/SAS connector is labeled (HDD1, HDD2, HDD3, HDD4) so you can easily determine their counterpart connectors at the back side of the backplane. Refer to the table for reference.



HDD Device	Front side connector	Back side connector
HDD 1	HDD1	CON1
HDD 2	HDD2	CON2
HDD 3	HDD3	CON3
HDD 4	HDD4	CON4

Back side

The back side of the SATA/SAS backplane faces the rear panel when installed. This side includes the power connectors and SATA/SAS interfaces for the motherboard Serial ATA connectors or the SAS card.

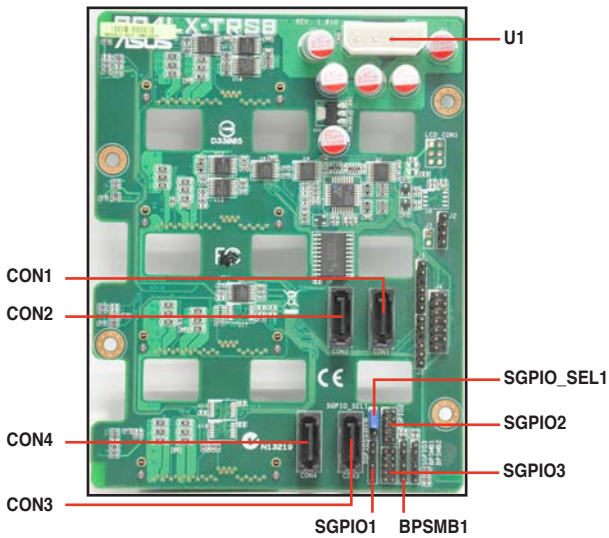

Connectors	Description
SGPIO1	Connects to SATA SGPIO1 connector on the motherboard
SGPIO2	Connects to SAS PSGPIO1 connector on the motherboard
SGPIO3	Connects to SAS PSGPIO2 connector on the motherboard
BPSMB1	Connects to Front panel SMB connector on the motherboard
U1	Connects to 4-pin plug of the power supply
CON1/CON2/ CON3/CON4	Connects to SATA/SAS connectors on the motherboard



Move the SGPIO_SEL1 jumper on the SATA/SAS backplane to 2–3 when installing the PIKE RAID card.

2.9 Removable components

You may need to remove previously installed system components when installing or removing system devices, or when you need to replace defective components. This section tells how to remove the following components:

1. System fans (front and rear)
2. Chassis footpads
3. Redundant power supply module

2.9.1 System fan

Removing the front system fan

To remove the front system fan:

1. Remove the two screws that secure the right side cover.

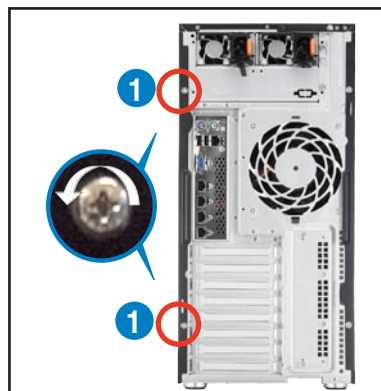

2. Locate the front system fan near the 5.25-inch drive bays.
3. Squeeze the front system fan latches (step a) and pull out the front system fan (step b), as shown in the right figure.
4. Follow the previous instructions in reverse to reinstall the front system fan.

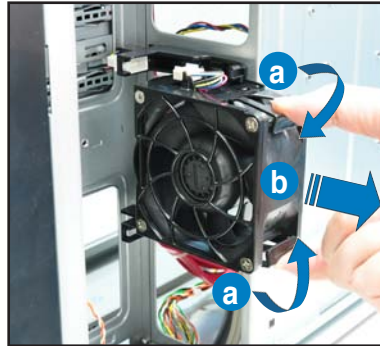

Removing the rear system fan

To remove the rear system fan:

1. Unplug the system fan cable from the REAR_FAN1 connector on the motherboard.
2. Shift the two hooked tabs leftward and rightward respectively, then carefully remove the system fan.
3. Follow the previous instructions in reverse to reinstall the rear system fan.



2.9.2 Chassis footpads

The barebone server system is shipped with four footpads attached to the bottom of the chassis for stability. You need to remove these footpads if you wish to install the system to a rack (Refer to Chapter 3: Installation options of this user guide, and to the “Rackmount Kit” user guide for instructions)

To remove the footpads:

1. Lay the system chassis on its side.
2. Remove the footpad by rotating it counterclockwise with a Philips (cross) screwdriver.
3. Repeat step 1 and 2 to remove the other three footpads.

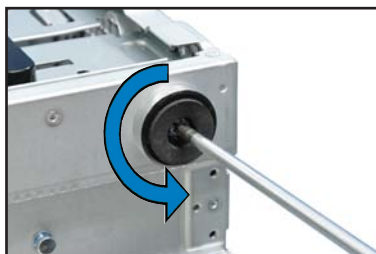

2.9.3 Redundant power supply module

The system is compatible with the 620W (for Taiwan only) and 800W redundant power supply module.



You **MUST** disconnect all power cable plugs from the motherboard and other installed devices before removing the power supply unit.

To install the redundant power supply module:

1. Remove the redundant power supply dummy cover.



800W redundant power supply

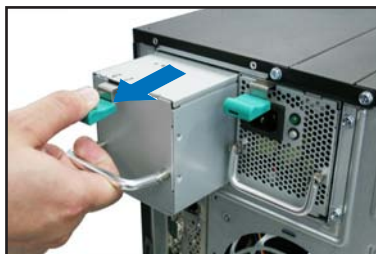

620W redundant power supply (for Taiwan only)

2. Take out the second redundant power supply module from its package. Slide it into the chassis.



620W redundant power supply (for Taiwan only)

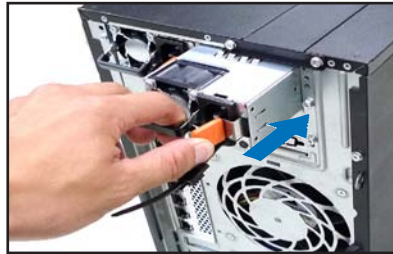

800W redundant power supply

3. Firmly pull the lever to slide the power supply module into the chassis.

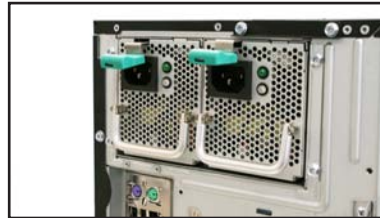

620W redundant power supply (for Taiwan only)



800W redundant power supply (for Taiwan only)

2.9.4 Fan Duct

This server system comes with a motherboard fan duct to enable better air flow inside the motherboard while the system is running.

To install the fan duct on the motherboard, refer to the illustration below.

Installation

1. Orient the fan duct as shown, aligning the three (3) screw holes with the designated screw holes on the motherboard.



Ensure that no cables or components are obstructing the fan duct.

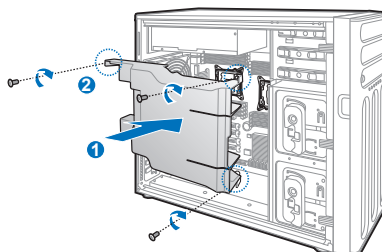

2. Secure the fan duct with three screws.

Removal

1. Remove the three (3) screws that secure the fan duct to the motherboard.
2. Carefully pull-out the fan duct out of the chassis.

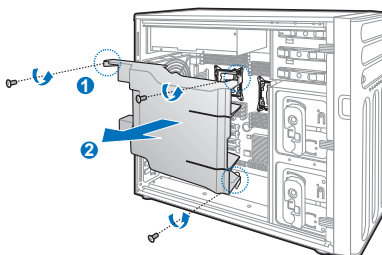

Installation options

3

3.1 Preparing the system for rack mounting



- The items required for the optional configurations described in this chapter are not included in the standard barebone system package. These items are purchased separately.
- We recommend that you allot at least 1U space above the server system to ensure optimal thermal performance.

Removing the footpads



Refer to section 2.9.2 Chassis footpads for instructions on removing the footpads.

Removing the top cover

Unscrew and slide the top cover toward the rear panel, and then lift it up from the chassis.



3.2 Attaching the inner rail to the server

1. Slide out the inner rail from the rackmount rail kit.
2. Align the screw holes on the inner rail and the chassis top, and then secure the inner rail to the chassis top with screws.

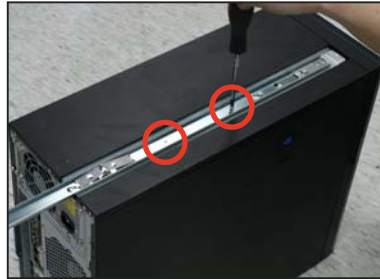

3. Repeat the previous steps to secure the other inner rail to the bottom of the chassis with screws.

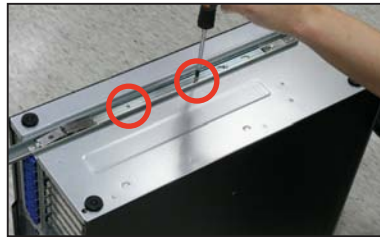

3.3 Attaching the rails to the rack

To attach the rails to the rack:

1. Select one unit of space (1U) on the rack where you wish to install the server.

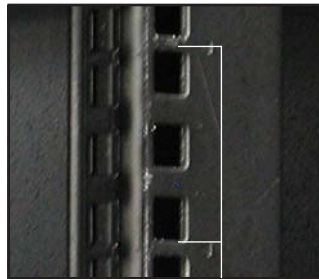

1U space

2. Loosen the two screws on the rack rails.

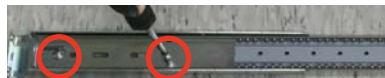

3. Align the front end holes of a rack rail pair to the 1U space.

4. Drive in two screws on the outer holes to secure the front end.

5. Find the rear 1U space that corresponds to the front 1U space where you attached the rail.

6. Drive in two screws on the outer holes to secure the rear end.

7. From the rack front, find the corresponding 1U space for the second rail pair.

8. Repeat steps 3–6 to attach the second rail pair.



3.4 Mounting the server to the rack

To mount the server to the rack:

1. Align the server rails with the rack rails.

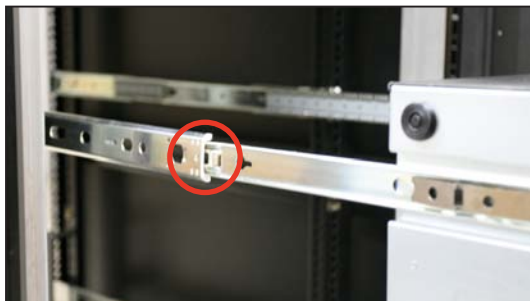

2. Push the server all the way into the rack.



Motherboard info

4

4.1 Motherboard layout

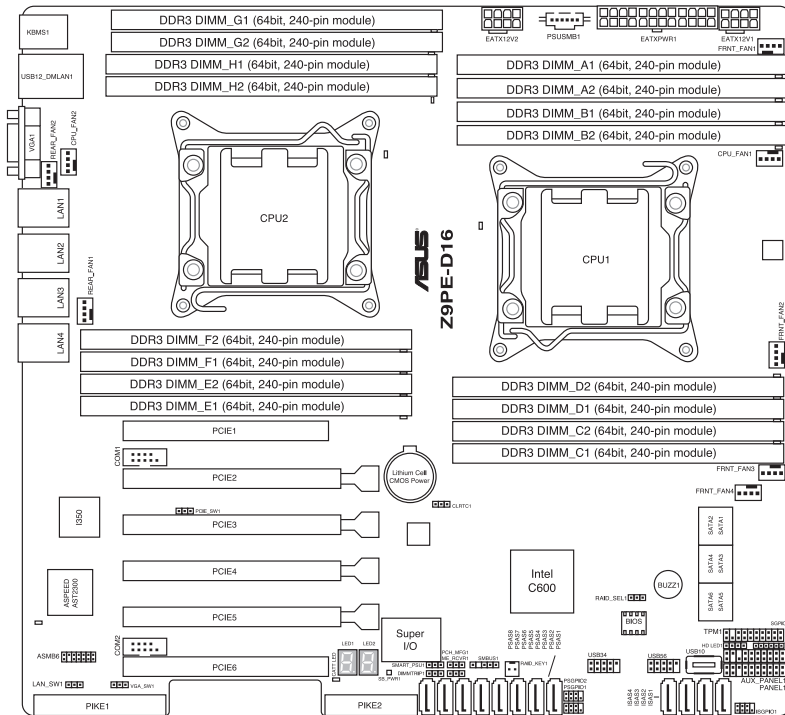

Layout contents

Jumpers	Page
1. Clear RTC RAM (CLRTC1)	4-3
2. VGA controller setting (3-pin VGA_SW1)	4-4
3. LAN controller setting (3-pin LAN_SW1)	4-4
4. LSI MegaRAID or Intel RSTe selection jumper (3-pin RAID_SEL1)	4-5
5. ME firmware force recovery setting (3-pin ME_RCVR1)	4-5
6. DDR3 thermal event setting (3-pin DIMMTRIP1)	4-6
7. PMBus 1.2 PSU select jumper (3-pin SMART_PSU1)	4-6

Internal connectors	Page
1. Serial ATA 6.0 / 3.0 Gb/s connectors (7-pin SATA6G_1-2 [Blue]) (7-pin SATA3G_3-6 [Black])	4-7
2. SATA connector --- ISAS connectors	4-7
3. USB connectors (10-1 pin USB34, USB56; A-Type USB10)	4-8
4. Hard disk activity LED connector (4-pin HDLED1)	4-8
5. SAS connectors --- PSAS connectors	4-9
6. CPU, front and rear fan connectors (4-pin CPU_FAN1-2, FRNT_FAN1-4, REAR_FAN1-2)	4-9
7. Serial General Purpose Input/Output connectors (8-1 pin PSGPIO 1/2, ISGPIO1/2, SGPIO1)	4-10
8. Serial port connectors (10-1 pin COM1/2)	4-10
9. TPM connector (20-pin TPM)	4-11
10. 24-pin EATXPWR1, 8-pin EATX12V1/EATX12V2, PSUSMB1)	4-12
11. System panel connector (20-1 pin PANEL1)	4-13
12. Auxiliary panel connector (20-2 pin AUX_PANEL1)	4-14

4.2 Jumpers

1. Clear RTC RAM (CLRRTC1)

This jumper allows you to clear the Real Time Clock (RTC) RAM in CMOS. You can clear the CMOS memory of date, time, and system setup parameters by erasing the CMOS RTC RAM data. The onboard button cell battery powers the RAM data in CMOS, which include system setup information such as system passwords.

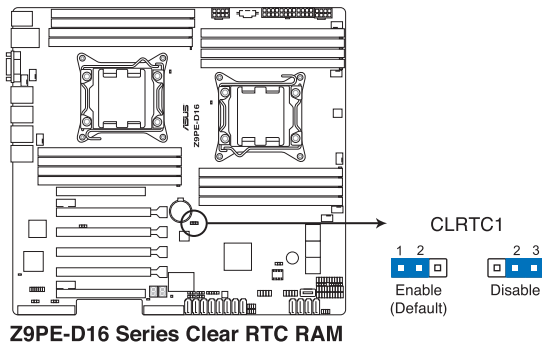

Z9PE-D16 Series Clear RTC RAM

To erase the RTC RAM:

1. Turn OFF the computer and unplug the power cord.
2. Move the jumper cap from pins 1–2 (default) to pins 2–3. Keep the cap on pins 2–3 for about 5–10 seconds, then move the cap back to pins 1–2.
3. Plug the power cord and turn ON the computer.
4. Hold down the key during the boot process and enter BIOS setup to re-enter data.



Except when clearing the RTC RAM, never remove the cap on CLRRTC jumper default position. Removing the cap will cause system boot failure!



If the steps above do not help, remove the onboard battery and move the jumper again to clear the CMOS RTC RAM data. After the CMOS clearance, reinstall the battery.

2. VGA controller setting (3-pin VGA_SW1)

This jumper allows you to enable or disable the onboard VGA controller. Set to pins 1–2 to activate the VGA feature.

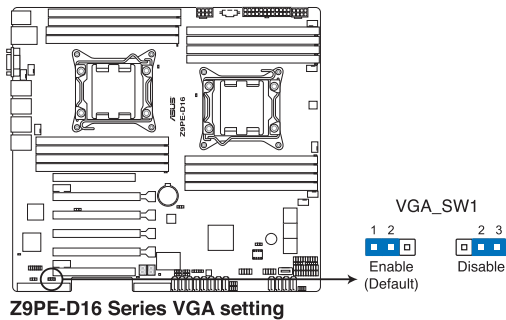

3. LAN controller setting (3-pin LAN_SW1)

These jumpers allow you to enable or disable the onboard Intel® I350 Gigabit LAN controllers. Set to pins 1-2 to activate the Gigabit LAN feature.

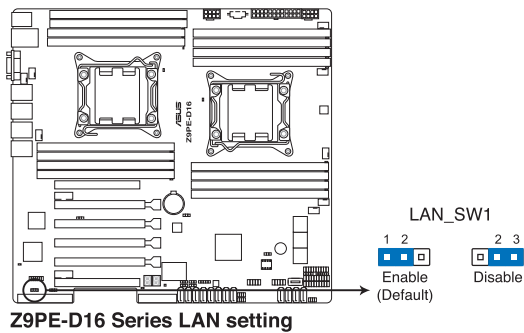

4. LSI MegaRAID or Intel RSTe selection jumper (3-pin RAID_SEL1)

This jumper allows you to select the PCH SATA RAID mode to use LSI MegaRAID software or Intel® Rapid Storage Technology enterprise 3.0 RAID. Place the jumper caps over pins 1–2 if you want to use the LSI MegaRAID software RAID Utility (default); otherwise, place the jumper caps to pins 2–3 to use the Intel® Rapid Storage Technology Enterprise Option ROM Utility.

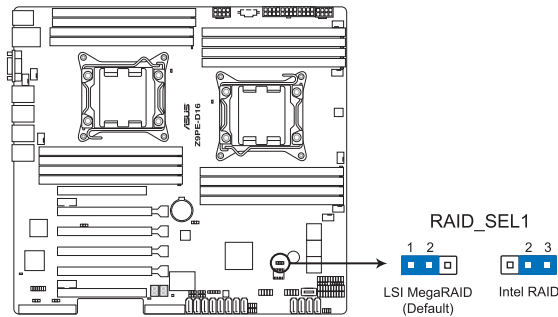

Z9PE-D16 Series RAID setting

5. ME firmware force recovery setting (3-pin ME_RCVR1)

This jumper allows you to force Intel Management Engine (ME) boot from recovery mode when ME become corrupted.

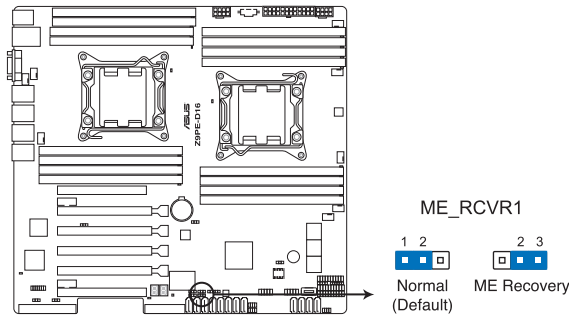

Z9PE-D16 Series ME recovery setting

6. DDR3 thermal event setting (3-pin DIMMTRIP1)

This jumper allows you to enable/disable DDR3 DIMM thermal sensing event pin.

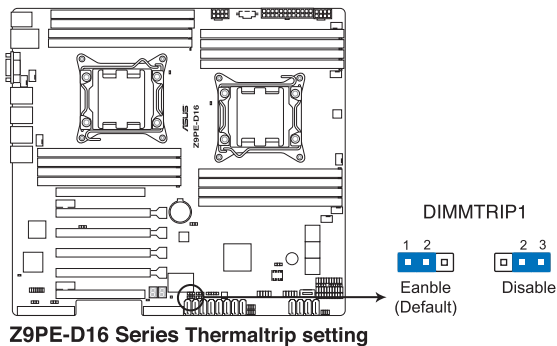

7. PMBus 1.2 PSU select jumper (3-pin SMART_PSU1)

This jumper allows you to select PSU PMBus version, Set to pins 1-2 for PMBus, set to pins 2-3 for Others.

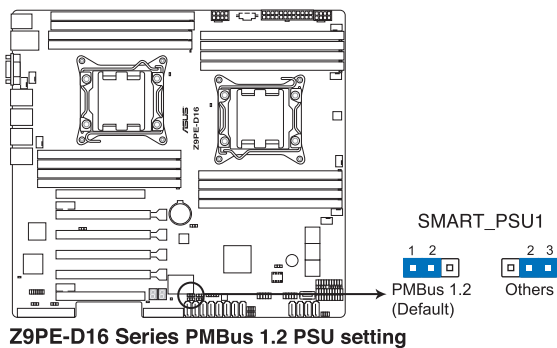

4.3 Internal connectors

1. Serial ATA 6.0/3.0 Gb/s connectors

(7-pin SATA6G_1-2 [Blue], and 7-pin SATA3G_3-6 [Black])

Supported by the Intel® 602 Chipset, these connectors are for the Serial ATA signal cables for Serial ATA hard disk drives that allows up to 6Gb/s of data transfer rate.

If you installed Serial ATA hard disk drives, you can create a RAID 0, RAID 1, RAID 10, or RAID 5 configuration.

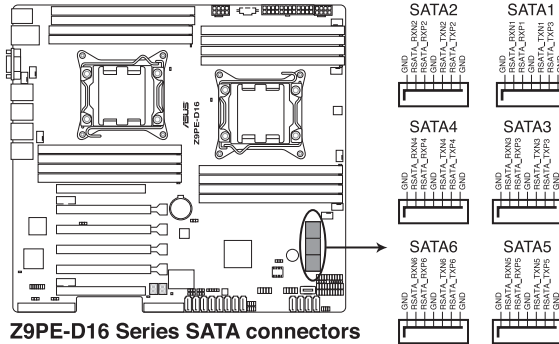

Z9PE-D16 Series SATA connectors

2. SATA connector -- ISAS connectors

Supported by the Intel® C602 PCH. ISAS 1-4 connectors can connect to serial ATA 3Gb/s hard disk drives.

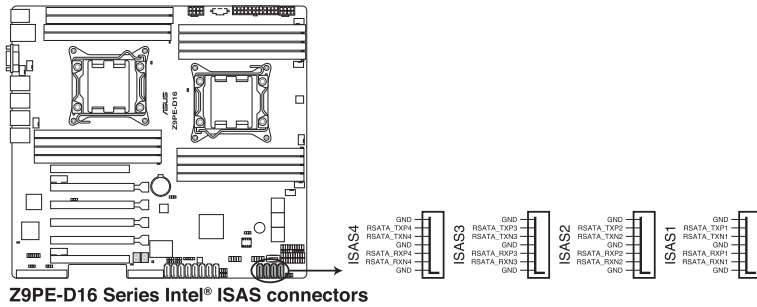

Z9PE-D16 Series Intel® ISAS connectors



The actual data transfer rate depends on the speed of SATA hard disks installed.

3. USB connectors (10-1 pin USB34, USB56; A-Type USB10)

These connectors are for USB 2.0 ports. Connect the USB module cables to connectors USB34 and USB56, then install the modules to a slot opening at the back of the system chassis. These USB connectors comply with USB 2.0 specification that supports up to 480 Mbps connection speed.

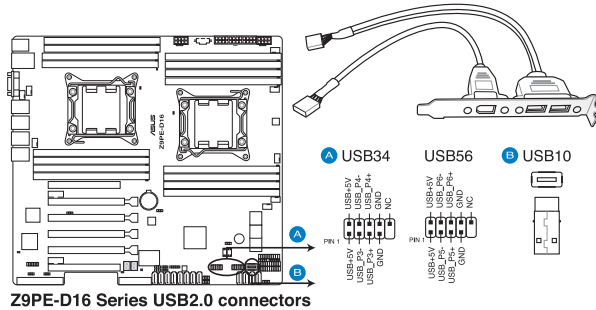

4. Hard disk activity LED connector (4-pin HDLED1)

This LED connector is for the storage add-on card cable connected to the SATA or SAS add-on card. The read or write activities of any device connected to the SATA or SAS add-on card causes the front panel LED to light up.

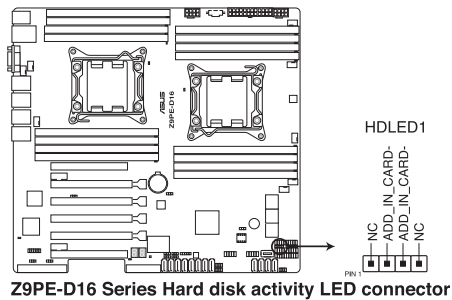

5. SAS connector -- PSAS connectors

SAS connector - PSAS connectors are for the SAS signal cables for SAS hard disk drives that allows up to 6Gb/s of data transfer rate.

If you installed SAS hard disk drives, you can create a RAID 0, RAID 1, RAID 10, or RAID 5 configuration.

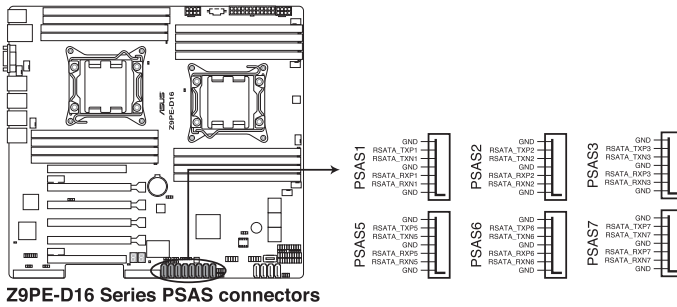

The actual data transfer rate depends on the speed of SAS hard disks installed.

6. CPU, front and rear fan connectors

(4-pin CPU_FAN1-2, FRNT_FAN1-4, REAR_FAN1-2)

The fan connectors support cooling fans. Connect the fan cables to the fan connectors on the motherboard, ensuring that the black wire of each cable matches the ground pin of the connector.

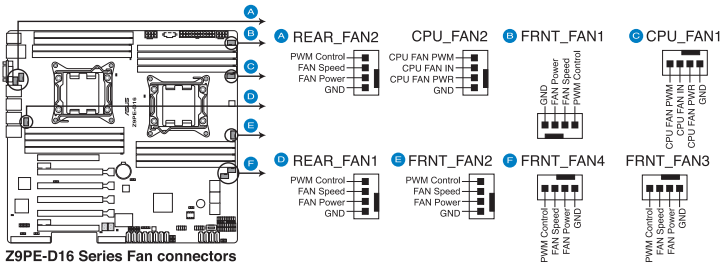

- DO NOT forget to connect the fan cables to the fan connectors. Insufficient air flow inside the system may damage the motherboard components.
- These are not jumpers! DO NOT place jumper caps on the fan connectors!
- All fans feature the ASUS Fan Speed Control technology.

7. Serial General Purpose Input/Output connectors (8-1 pin PSGPIO 1/2, ISGPIO1, SGPIO1)

The SGPIO 1 connectors are used for the Intel Rapid Storage Technology Enterprise SGPIO interface that controls the LED pattern generation, device information and general purpose data.

The PSGPIO 1/2 connectors are used for PIKE card.

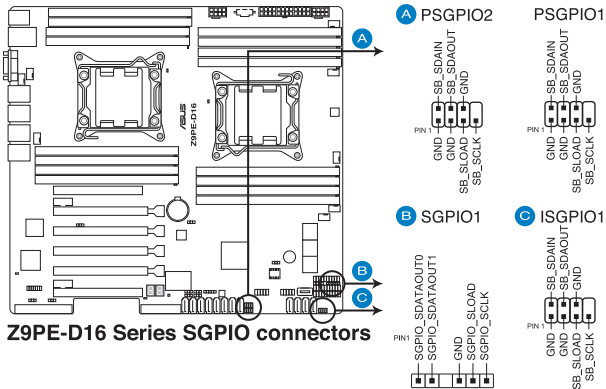

8. Serial port connectors (10-1 pin COM1/COM2)

These connectors are for the serial (COM) ports. Connect the serial port module cable to one of these connectors, then install the module to a slot opening at the back of the system chassis.

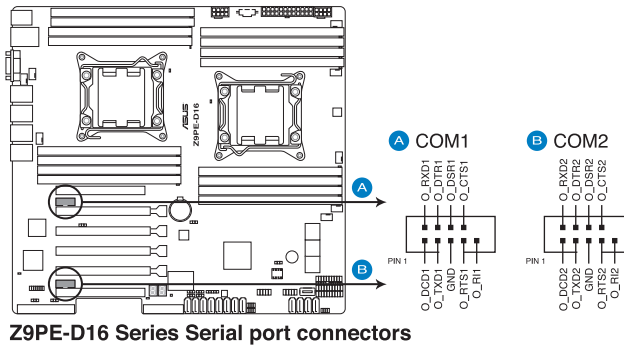

9. TPM connector (20-pin TPM)

This connector supports a Trusted Platform Module (TPM) system, which can securely store keys, digital certificates, passwords, and data. A TPM system also helps enhance network security, protects digital identities, and ensures platform integrity.

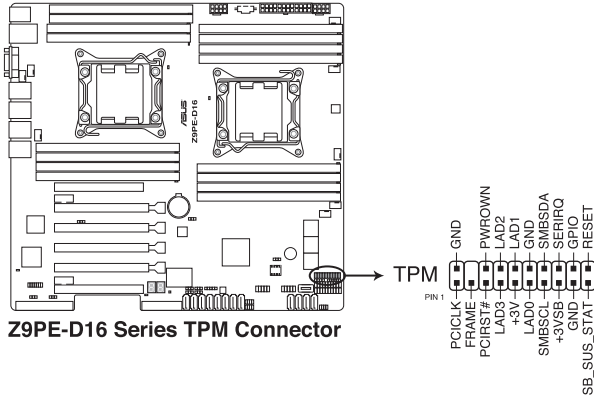

Z9PE-D16 Series TPM Connector

10. EATX power connectors

(24-pin EATXPWR1, 8-pin EATX12V1/EATX12V2, PSUSMB1)

These connectors are for an EATX power supply plugs. The power supply plugs are designed to fit these connectors in only one orientation. Find the proper orientation and push down firmly until the connectors completely fit.

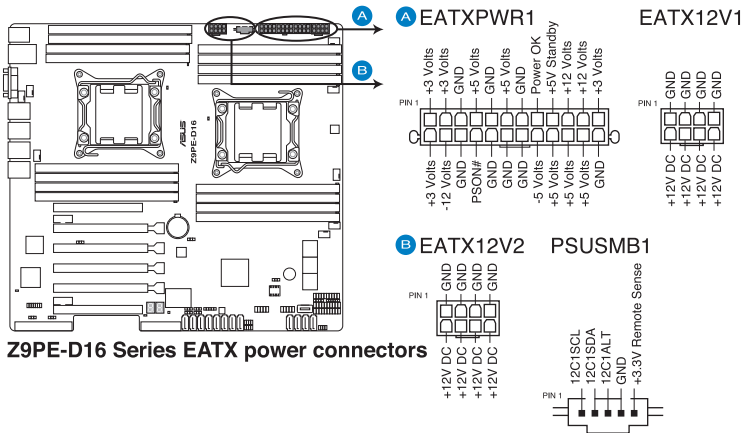

- **DO NOT** forget to connect the 24+8+8-pin power plugs; otherwise, the system will not boot up.
- Use of a PSU with a higher power output is recommended when configuring a system with more power-consuming devices. The system may become unstable or may not boot up if the power is inadequate.
- This motherboard supports EATX2.0 PSU or later version.
- Ensure that your power supply unit (PSU) can provide at least the minimum power required by your system.

11. System panel connector (20-pin PANEL1)

This connector supports several chassis-mounted functions.

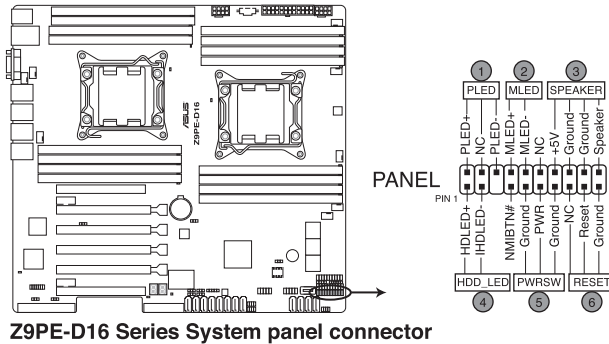

(1) System power LED (3-pin PLED)

This 3-pin connector is for the system power LED. Connect the chassis power LED cable to this connector. The system power LED lights up when you turn on the system power, and blinks when the system is in sleep mode.

(2) Message LED (2-pin MLED)

This 2-pin connector is for the message LED cable that connects to the front message LED. The message LED is controlled by Hardware monitor to indicate an abnormal event occurrence.

(3) System warning speaker (4-pin SPEAKER)

This 4-pin connector is for the chassis-mounted system warning speaker. The speaker allows you to hear system beeps and warnings.

(4) Hard disk drive activity LED (2-pin HDDLED)

This 2-pin connector is for the HDD Activity LED. Connect the HDD Activity LED cable to this connector. The HDD LED lights up or flashes when data is read from or written to the HDD.

(5) Power button/soft-off button (2-pin PWRSW)

This connector is for the system power button. Pressing the power button turns the system on or puts the system in sleep or soft-off mode depending on the BIOS settings. Pressing the power switch for more than four seconds while the system is ON turns the system OFF.

(6) Reset button (2-pin RESET)

This 2-pin connector is for the chassis-mounted reset button for system reboot without turning off the system power.

12. Auxiliary panel connector (20-2 pin AUX_PANEL1)

This connector is for additional front panel features including front panel SMB, locator LED and switch, chassis intrusion, and LAN LEDs.

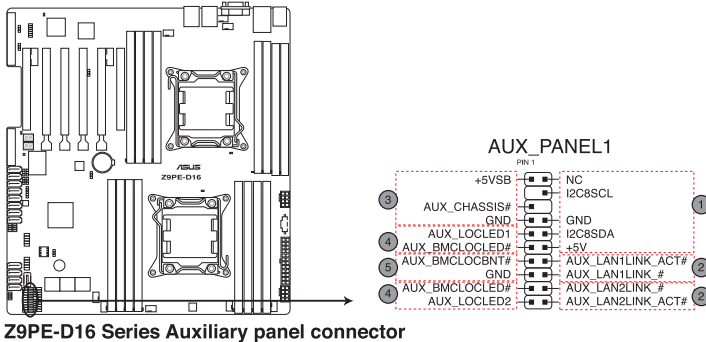

Z9PE-D16 Series Auxiliary panel connector

(1) Front panel SMB (6-1 pin FPSMB)

These leads connect the front panel SMBus cable.

(2) LAN activity LED (2-pin LAN13_LED, LAN24_LED)

These leads are for Gigabit LAN activity LEDs on the front panel.

(3) Chassis intrusion (4-1 pin CHASSIS)

These leads are for the intrusion detection feature for chassis with intrusion sensor or microswitch. When you remove any chassis component, the sensor triggers and sends a high-level signal to these leads to record a chassis intrusion event. The default setting is short CASEOPEN and GND pin by jumper cap to disable the function.

(4) Locator LED (2-pin LOCATORLED1 and 2-pin LOCATORLED2)

These leads are for the locator LED1 and LED2 on the front panel. Connect the Locator LED cables to these 2-pin connector. The LEDs will light up when the Locator button is pressed.

(5) Locator Button/Switch (2-pin LOCATORBTN)

These leads are for the locator button on the front panel. This button queries the state of the system locator.

BIOS setup

5

5.1 Managing and updating your BIOS

Use the following utilities to manage and update the motherboard's Basic Input/Output (BIOS) settings:

1. **ASUS CrashFree BIOS 3:** This utility allows you to recover the BIOS using a bootable USB flash disk drive when the BIOS file fails or gets corrupted.
2. **ASUS EZ Flash 2:** This utility allows you to update the BIOS using a USB flash disk.
3. **BUPDATER:** This utility allows you to update the BIOS in DOS mode using a bootable USB flash disk drive.)



Save a copy of the original motherboard BIOS file to a bootable USB flash disk drive in case you need to restore the BIOS in the future. Copy the original motherboard BIOS using the BUPDATER utility.

5.1.1 ASUS CrashFree BIOS 3

ASUS CrashFree BIOS 3 is an auto recovery tool that allows you to restore the BIOS file when it fails or gets corrupted during the updating process. You can update a corrupted BIOS file using a USB flash drive that contains the BIOS file.



Prepare a USB flash drive containing the BIOS file before using this utility.

Recovering the BIOS from a USB flash drive

To recover the BIOS from a USB flash drive:

1. Insert the USB flash drive containing the BIOS file to the system's USB port. The utility will automatically recover the BIOS. It resets the system when the BIOS recovery is finished.



DO NOT shut down or reset the system while recovering the BIOS! Doing so would cause system boot failure!



The recovered BIOS may not be the latest BIOS version for this motherboard. Visit the ASUS website at www.asus.com to download the latest BIOS file.

5.1.2 ASUS EZ Flash 2

ASUS EZ Flash 2 allows you to update the BIOS without having to use a bootable floppy disk or an OS-based utility.



Before you start using this utility, download the latest BIOS from the ASUS website at www.asus.com

To update the BIOS using EZ Flash 2:

1. Insert the USB flash disk that contains the latest BIOS file to the system's USB port.
2. Enter the BIOS setup program. Go to the Tool menu to select **ASUS EZ Flash Utility**. Press <Enter>.

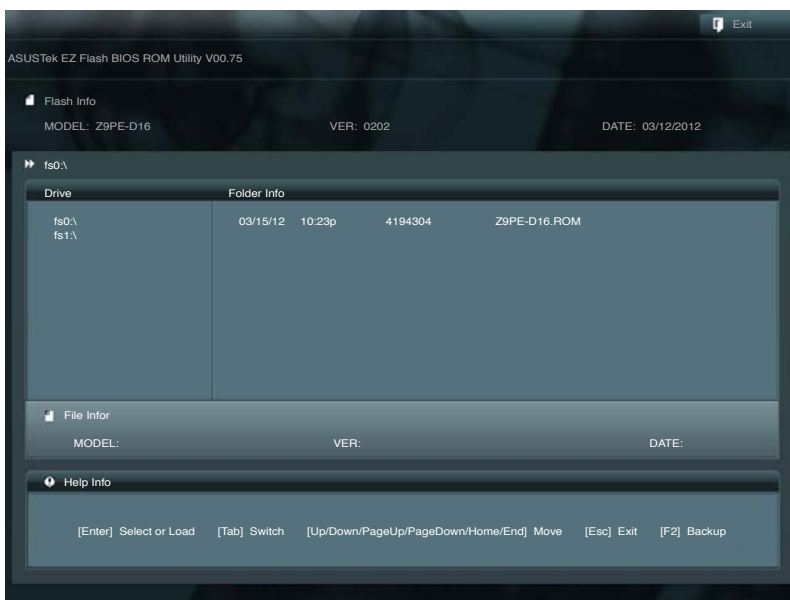

3. Press <Tab> to switch to the Drive field.
4. Press the Up/Down arrow keys to find the USB flash disk that contains the latest BIOS, and then press <Enter>.
5. Press <Tab> to switch to the Folder Info field.
6. Press the Up/Down arrow keys to find the BIOS file, and then press <Enter> to perform the BIOS update process. Reboot the system when the update process is done.



This function can support devices such as a USB flash disk with FAT 32/16 format and single partition only.

DO NOT shut down or reset the system while updating the BIOS to prevent system boot failure!



Ensure to load the BIOS default settings to ensure system compatibility and stability. Press <F5> and select **Yes** to load the BIOS default settings.

5.1.3 BUPDATER



The succeeding BIOS screens are for reference only. The actual BIOS screen displays may not be the same as shown.

BUPDATER allows you to update the BIOS file in the DOS environment using a bootable USB flash disk drive containing the BIOS file.

Updating the BIOS file

To update the BIOS file using the BUPDATER utility:

1. Visit the ASUS website at www.asus.com and download the latest BIOS file for the motherboard. Save the BIOS file to a bootable USB flash disk drive.
2. Copy the BUPDATER utility (BUPDATER.exe) from the ASUS support website at support.asus.com to the bootable USB flash disk drive.
3. Boot the system in DOS mode, then at the prompt, type:

BUPDATER /i[filename].ROM

where [filename] is the latest or the original BIOS file on the bootable USB flash disk drive, then press <Enter>.

```
A:\>BUPDATER /i[file name].ROM
```

- The utility verifies the file, then starts updating the BIOS file.

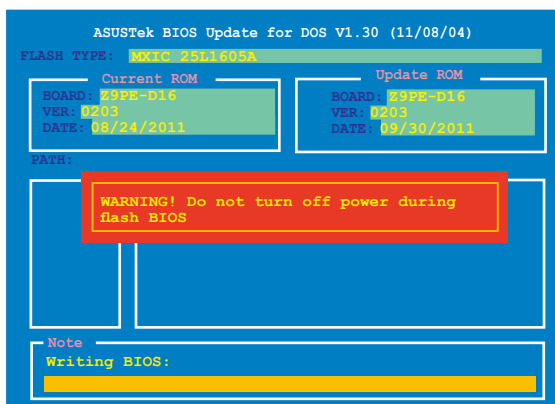

DO NOT shut down or reset the system while updating the BIOS to prevent system boot failure!

- The utility returns to the DOS prompt after the BIOS update process is completed. Reboot the system from the hard disk drive.

```
The BIOS update is finished! Please restart your system.  
c:\>
```

5.2 BIOS setup program

Use the BIOS Setup to update the BIOS or configure its parameters. The BIOS screen include navigation keys and brief onscreen help to guide you in using the BIOS Setup program.

Entering BIOS at startup

To enter BIOS Setup at startup:

- Press <Delete> during the Power-On Self Test (POST). If you do not press <Delete>, POST continues with its routines.

Entering BIOS Setup after POST

To enter BIOS Setup after POST:

- Press <Ctrl>+<Alt>+<Delete> simultaneously.
- Press the reset button on the system chassis.
- Press the power button to turn the system off then back on. Do this option only if you failed to enter BIOS Setup using the first two options.



-
- The default BIOS settings for this motherboard apply for most conditions to ensure optimum performance. If the system becomes unstable after changing any BIOS settings, load the default settings to ensure system compatibility and stability. Press <F5> and select Yes to load the BIOS default settings.
 - The BIOS setup screens shown in this section are for reference purposes only, and may not exactly match what you see on your screen.
 - Visit the ASUS website at www.asus.com to download the latest BIOS file for this motherboard.
-

5.2.1 BIOS menu screen

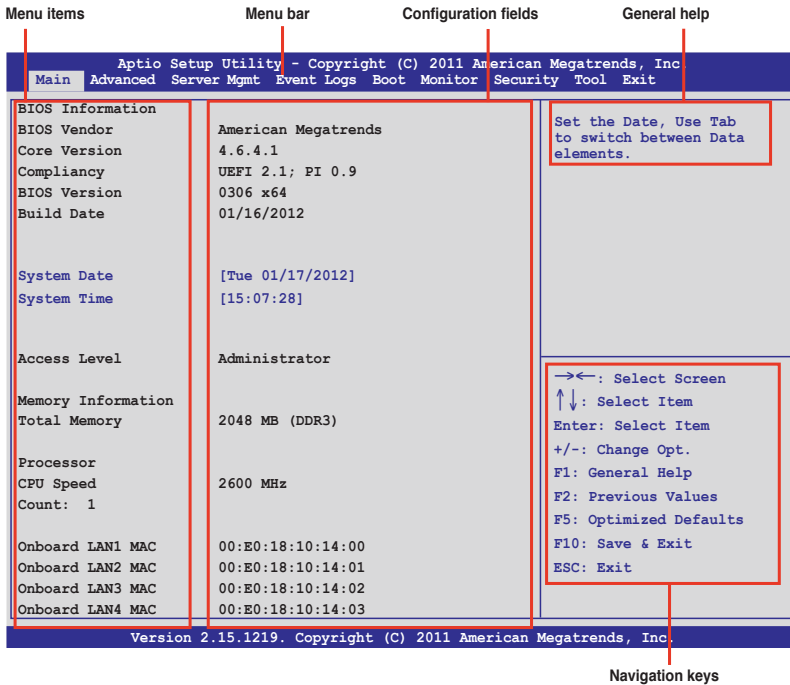

5.2.2 Menu bar

The menu bar on top of the screen has the following main items:

Main	For changing the basic system configuration
Advanced	For changing the advanced system settings
Server Mgmt	For changing the Server Mgmt settings
Event Logs	For changing the event log settings
Monitor	For displaying the system temperature, power status, and changing the fan settings
Security	For changing the security settings
Boot	For changing the system boot configuration
Tool	For configuring options for special functions
Exit	For selecting the exit options

To select an item on the menu bar, press the right or left arrow key on the keyboard until the desired item is highlighted.

5.2.3 Menu items

The highlighted item on the menu bar displays the specific items for that menu. For example, selecting Main shows the Main menu items.

The other items (Event Logs, Advanced, Monitor, Boot, Tool, and Exit) on the menu bar have their respective menu items.

5.2.4 Submenu items

A solid triangle before each item on any menu screen means that the item has a submenu. To display the submenu, select the item then press <Enter>.

5.2.5 Navigation keys

At the bottom right corner of a menu screen are the navigation keys for the BIOS setup program. Use the navigation keys to select items in the menu and change the settings.

5.2.6 General help

At the top right corner of the menu screen is a brief description of the selected item.

5.2.7 Configuration fields

These fields show the values for the menu items. If an item is user-configurable, you can change the value of the field opposite the item. You cannot select an item that is not user-configurable.

A configurable field is enclosed in brackets, and is highlighted when selected. To change the value of a field, select it and press <Enter> to display a list of options.

5.2.8 Pop-up window

Select a menu item and press <Enter> to display a pop-up window with the configuration options for that item.

5.2.9 Scroll bar

A scroll bar appears on the right side of a menu screen when there are items that do not fit on the screen. Press the Up/Down arrow keys or <Page Up> /<Page Down> keys to display the other items on the screen.

5.3 Main menu

When you enter the BIOS Setup program, the Main menu screen appears. The Main menu provides you with an overview of the basic system information, and allows you to set the system date, time, language, and security settings.

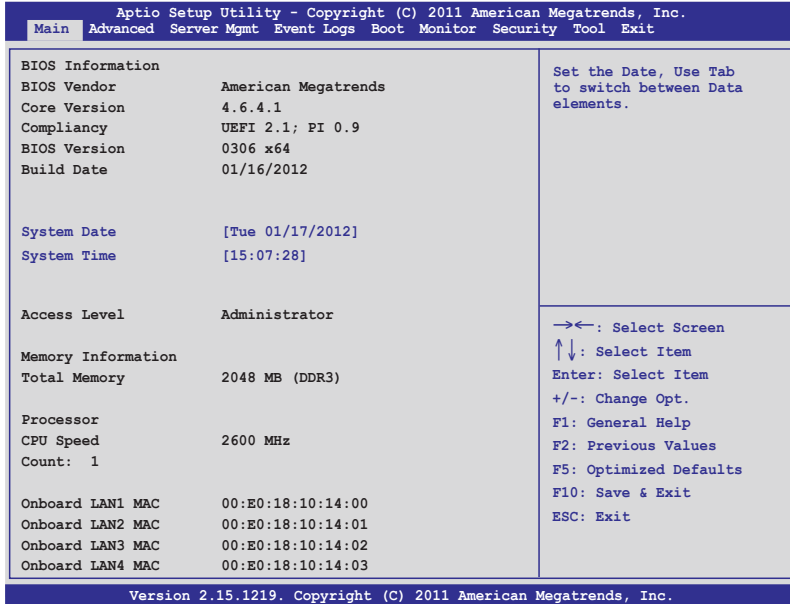

5.3.1 System Date [Day xx/xx/xxxx]

Allows you to set the system date.

5.3.2 System Time [xx:xx:xx]

Allows you to set the system time.

5.4 Advanced menu

The Advanced menu items allow you to change the settings for the CPU and other system devices.



Be cautious when changing the settings of the Advanced menu items. Incorrect field values can cause the system to malfunction.

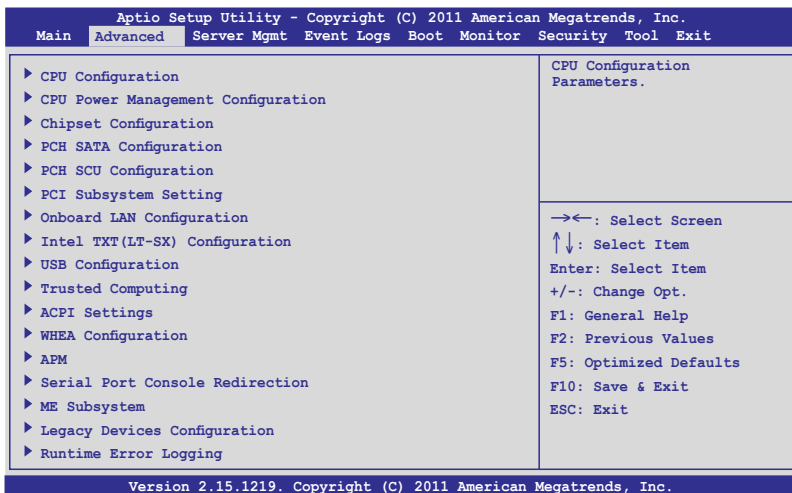

5.4.1 CPU Configuration

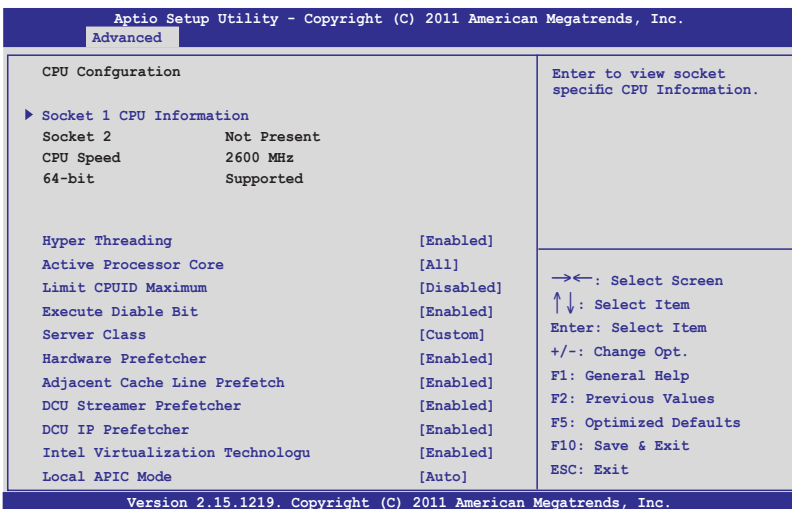

Socket 1 CPU Information

Enter to view the socket's specific CPU Information.

The screenshot shows the 'Advanced' tab of the Aptio Setup Utility. The title bar reads 'Aptio Setup Utility - Copyright (C) 2011 American Megatrends, Inc.' and the current tab is 'Advanced'. The main content area is divided into two columns. The left column, titled 'Socket 1 CPU Information', lists various CPU specifications: Genuine Intel(R) CPU @ 2.60GHz, CPU Signature 206d5, Microcode Patch 512, Max CPU Speed 2600 MHz, Min CPU Speed 1200 MHz, Processor Cores 8, Intel HT Technology Supported, Intel VT-X Technology Supported, L1 Data Cache 32 kB x8, L1 Code Cache 32 kB x8, L2 Cache 256 kB x8, and L3 Cache 20480 kB. The right column contains the instruction 'Enter to view socket specific CPU Information.' and a list of navigation keys: →←: Select Screen, ↑↓: Select Item, Enter: Select Item, +/-: Change Opt., F1: General Help, F2: Previous Values, F5: Optimized Defaults, F10: Save & Exit, and ESC: Exit. At the bottom of the window, the version number 'Version 2.15.1219. Copyright (C) 2011 American Megatrends, Inc.' is displayed.

Socket 1 CPU Information	
Genuine Intel(R) CPU @ 2.60GHz	
CPU Signature	206d5
Microcode Patch	512
Max CPU Speed	2600 MHz
Min CPU Speed	1200 MHz
Processor Cores	8
Intel HT Technology	Supported
Intel VT-X Technology	Supported
L1 Data Cache	32 kB x8
L1 Code Cache	32 kB x8
L2 Cache	256 kB x8
L3 Cache	20480 kB

Enter to view socket specific CPU Information.

→←: Select Screen
↑↓: Select Item
Enter: Select Item
+/-: Change Opt.
F1: General Help
F2: Previous Values
F5: Optimized Defaults
F10: Save & Exit
ESC: Exit

Version 2.15.1219. Copyright (C) 2011 American Megatrends, Inc.

Hyper Threading [Enabled]

Allows you to enable or disable the Intel® Hyper-Threading Technology function. When disabled, only one thread per activated core is enabled.

Configuration options: [Disabled] [Enabled]

Active Processor Cores [All]

Configuration options: [All] [1] [2] [3] [4] [5] [6] [7]

Limit CPUID Maximum [Disabled]

Setting this item to [Enabled] allows legacy operating system to boot even without support for CPUs with extended CPUID functions.

Configuration options: [Disabled] [Enabled]

Execute Disable Bit [Enabled]

XD can prevent certain classes of malicious buffer overflow attacks when combined with a supporting OS (Windows Server 2003 SP1, Windows XP SP2, SuSE Linux 9.2, Redhat Enterprise 3 Update 3).

Configuration options: [Disabled] [Enabled]

Server Class [Custom]

Allows you to use Intel® recommended prefetch settings.

Configuration options: [Enterprise] [High Performance(HPC)] [Custom]

Hardware Prefetcher [Enabled]

Allows you to turn on/off the mid level cache(L2) streamer prefetcher. Configuration options: [Disabled] [Enabled]

Adjacent Cache Line Prefetch [Enabled]

Allows you to turn on/off prefetching of adjacent cache lines.

Configuration options: [Disabled] [Enabled]

DCU Streamer Prefetcher [Enabled]

Allows you to enable or disable prefetcher of next L1 data line.

Configuration options: [Disabled] [Enabled]

DCU IP Prefetcher [Enabled]

Allows you to enable or disable prefetch of next L1 line based upon sequential load history. Configuration options: [Disabled] [Enabled]

Intel® Virtualization Technology [Enabled]

When this item is enabled, a VMM can utilize the additional hardware capabilities provided by Vanderpool Technology. Configuration options: [Disabled] [Enabled]

Local APIC Mode [Disabled]

Select the Local APIC mode. If Auto, use x2APIC if required. Otherwise, use xAPIC mode. xAPIC will disable CPUs with APIC IDs greater than 254. Some OS do not support x2APIC mode. Configuration options: [Disabled] [Enabled]

5.4.2 CPU Power Management Configuration

Aptio Setup Utility - Copyright (C) 2011 American Megatrends, Inc.	
Main Advanced Server Mgmt Event Logs Boot Monitor Security Tool Exit	
CPU Power Management Configuration	
Power Technology	[Custom]
EIST	[Enabled]
Turbo Mode	[Enabled]
P-STATE Coordination	[HW_ALL]
CPU C3 Report	[Disabled]
CPU C6 Report	[Enabled]
CPU C7 Report	[Disabled]
Package C State limit	[C6]
Energy Performance	[Balanced Performance]
Factory long duration power limit	115 Watts
Long duration power limit	0
Factory long duration maintained	1000 ms
Long duration power limit	0
Recommended short duration power limit	1.2 * Long Duration
Short duration power limit	0
This item allows you to enabled power management features.	
→←: Select Screen ↑↓: Select Item Enter: Select Item +/-: Change Opt. F1: General Help F2: Previous Values F5: Optimized Defaults F10: Save & Exit ESC: Exit	
Version 2.15.1219. Copyright (C) 2011 American Megatrends, Inc.	

Power Technology [Custom]

Allows you to enable power management features.

Configuration options: [Disabled] [Energy Efficient] [Custom]

EIST [Enabled]

Allows you to enable/disable Intel® SpeedStep.

Configuration options: [Disabled] [Enabled]

Turbo Mode [Enabled]

Configuration options: [Disabled] [Enabled]

P-STATE Coordination [HW_ALL]

Allows you to change P-STATE Coordination type.

Configuration options: [HW_ALL] [SW_ALL] [SW_ANY]

CPU C3 Report [Disabled]

Allows you to enable/disable CPU C3(ACPI C2) report.

Configuration options: [Disabled] [Enabled]

CPU C6 Report [Enabled]

Allows you to enable/disable CPU C6(ACPI C3) report.

Configuration options: [Disabled] [Enabled]

CPU C7 Report [Disabled]

Allows you to enable/disable CPU C7(ACPI C3) report.

Configuration options: [Disabled] [Enabled]

Package C State limit [C6]

Allows you to set the package C State limit.

Configuration options: [C0] [C2] [C6] [C7] [No Limit]

Energy Performance [Balanced Performance]

Allows you to manage the system performance and power saving efficiency.

Windows 2008 and later operating systems override this value according to this power plan.

Configuration options: [Performance] [Balanced Performance] [Balanced Energy] [Energy Efficient]

Factory long duration power limit **115 Watts**

Long duration power limit **0**

Allows you to set the long duration power limit in watts. Use the number keys to set the value.

Factory long duration maintained **1000 ms**

Long duration power limit **0**

Allows you to set the time window that the long duration power is maintained. Use the number keys to set the value.

Recommended short duration power limitation Duration **1.2 * Long**

Short duration power limit **0**

Allows you to set the short duration power limit in watts. Use the number keys to set the value.

5.4.3 Chipset Configuration

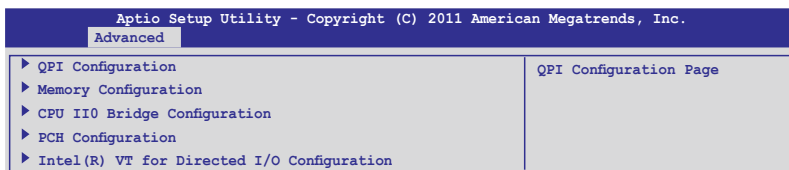

QPI Configuration

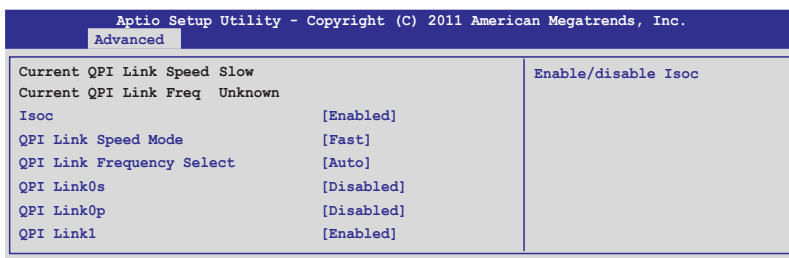

Isoc [Enabled]

Configuration options: [Disabled] [Enabled]

QPI Link Speed Mode [Fast]

Allows you to select the QPI link speed.

Configuration options: [Slow] [Fast]

QPI Link Frequency Select [Auto]

Allows you to select the QPI link frequency. Configuration options: [Auto] [6.4 GT/s] [7.2 GT/s (Fast Mode Only)] [8.0 GT/s (Fast Mode Only)]

QPI Link0s [Disabled]

Configuration options: [Disabled] [Enabled]

QPI Link0p [Disabled]

Configuration options: [Disabled] [Enabled]

QPI Link1 [Enabled]

Configuration options: [Disabled] [Enabled]

Memory Configuration

Aptio Setup Utility - Copyright (C) 2011 American Megatrends, Inc.

Advanced

Compatibility RID	[Enabled]	▲	Support for compatibility Revision ID (CRID) functionality mentioned in Sandy Bridge BIOS spec.
Memory Configuration			
Total Memory	2048 MB (DDR3)		
Current Memory Mode	Independent		
Currently Memory Speed	1333 MHz	▼	
Mirroring	Supported		
Sparing Not Possible			
Memory Mode	[Independent]		
DDR Speed	[Auto]		
Channel Interleaving	[Auto]		
Rank Interleaving	[Auto]		
Patrol Scrub	[Disabled]		
Demand Scrub	[Enabled]		
Data Scrambling	[Enabled]		
Device Tagging	[Disabled]		
Thermal Throtting	[CLTT]		
OLTT Peak BW %	50		
Enable High Temp	[Disabled]		
Allow 2x Refresh	[Enabled]		
Altitude	[300 M]		
Memory HOT Sensor support	[Enabled]		
▶ DIMM Information			

→←: Select Screen
↑↓: Select Item
Enter: Select Item
+/-: Change Opt.
F1: General Help
F2: Previous Values
F5: Optimized Defaults
F10: Save & Exit
ESC: Exit

Version 2.15.1219. Copyright (C) 2011 American Megatrends, Inc.

Compatibility RID [Enabled]

Allows you to enable/disable the compatibility revision ID (CRID) functionality mentioned in Sandybridge BIOS specification.

Configuration options: [Enabled] [Disabled]

Memory Mode [Independent]

Allows you to select the mode for memory initialization. Configuration options: [Independent] [Mirroring] [Lock Step] [Sparing]

DDR Speed [Auto]

Allows you to force DDR speed. Configuration options: [Auto] [Force DDR3 800] [Force DDR3 1066] [Force DDR3 1333] [Force DDR3 1600] [Force DDR3 1866]

Channel Interleaving [Auto]

Allows you to select different channel interleaving setting.

Configuration options: [Auto] [1 Way] [2 Way] [3 Way] [4 Way]

Rank Interleaving [Auto]

Allows you to select different rank interleaving setting.

Configuration options: [Auto] [1 Way] [2 Way] [4 Way] [8 Way]

Patrol Scrub [Disabled]

Allows you to enable/disable Patrol Scrub.

Configuration options: [Disabled] [Enabled]

Demand Scrub [Enabled]

Allows you to enable/disable the demand scrubbing feature.

Configuration options: [Enabled] [Disabled]

Data Scrambling [Enabled]

Allows you to enable/disable data scrambling.

Configuration options: [Enabled] [Disabled]

Device Tagging [Disabled]

Allows you to enable/disable device tagging.

Configuration options: [Enabled] [Disabled]

Thermal Throttling [CLTT]

Configuration options: [Disabled] [OLTT] [CLTT]

Enable High Temp [Disabled]

Configuration options: [Disabled] [Enabled]

Allow 2x Refresh [Enabled]

Configuration options: [Disabled] [Enabled]

Altitude [300 M]

Configuration options: [Auto] [300 M] [900 M] [1500 M] [3000 M]

Memory Hot sensor support [Enabled]

Configuration options: [Disabled] [Enabled]

DIMM Information

Aptio Setup Utility - Copyright (C) 2011 American Megatrends, Inc.	
Advanced	
CPU1 DIMM Information	
Node 0 Ch0 Dimm A1	Present 2048 MB (DDR3)
Node 0 Ch0 Dimm A2	Not Present
Node 0 Ch1 Dimm B1	Not Present
Node 0 Ch1 Dimm B2	Not Present
Node 0 Ch2 Dimm C1	Not Present
Node 0 Ch2 Dimm C2	Not Present
Node 0 Ch3 Dimm D1	Not Present
Node 0 Ch3 Dimm D2	Not Present
CPU2 DIMM Information	

CPU I/O Bridge Configuration

Aptio Setup Utility - Copyright (C) 2011 American Megatrends, Inc.		
Advanced		
Intel(R) I/OAT	[Disabled]	Enables/Disables Intel(R) I/O Acceleration Technology (I/OAT).
DCA Support	[Enabled]	
VGA Priority	[Offboard]	
TargetVGA	VGA From CPU 0	
		→←: Select Screen ↑↓: Select Item Enter: Select Item +/-: Change Opt. F1: General Help F2: Previous Values F5: Optimized Defaults F10: Save & Exit ESC: Exit

Version 2.15.1219. Copyright (C) 2011 American Megatrends, Inc.

Intel(R) I/OAT [Disabled]

Allows you to enable/disable Intel® I/O acceleration technology.

Configuration options: [Disabled] [Enabled]

DCA Support [Enabled]

Allows you to enable/disable the direct cache access support.

Configuration options: [Disabled] [Enabled]

VGA Priority [offboard]

Allows you to prioritize between the onboard and the 1st offboard video device.

Configuration options: [Onboard] [Offboard]

PCH Configuration

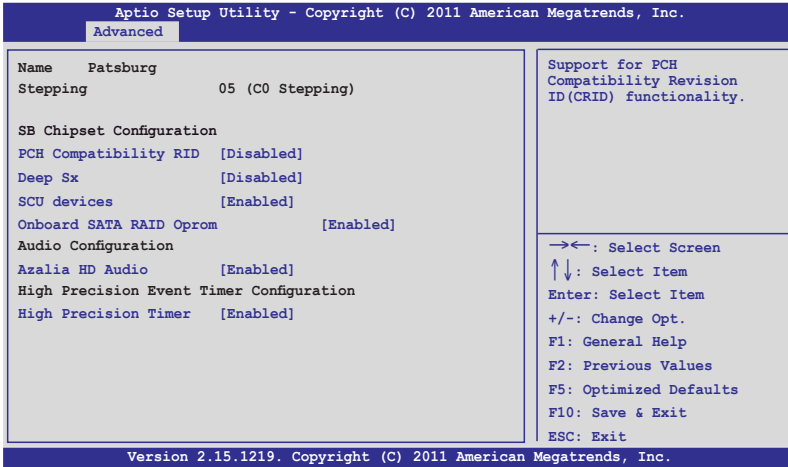

PCH Compatibility RID [Disabled]

Support for PCH compatibility.

Configuration options: [Disabled] [Enabled]

Deep Sx [Disabled]

Configuration options: [Disabled] [Enabled in S5] [Enabled in S4 and S5]



Mobile platforms support deep S4/S5 in DC only and desktop platforms support deep S4/S5 in AC only.

SCU devices [Enabled]

Allows you to enable/disable the Patsburg SCU devices.

Configuration options: [Enabled] [Disabled]

Onboard SATA RAID OproM [Enabled]

Allows you to enable/disable the onboard SATA RAID option rom if Launch Storage OproM is enabled. Configuration options: [Disabled] [Enabled]

Audio Configuration

Azalia HD Audio [Enabled]

Allows you to enable/disable the Azalia HD Audio.

Configuration options: [Disabled] [Enabled]

High Precision Event Timer Configuration

High Precision Timer [Enabled]

Allows you to enable/disable the High Precision Event Timer.

Configuration options: [Disabled] [Enabled]

Intel(R) VT for Directed I/O Configuration

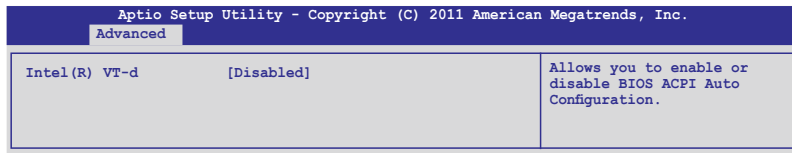

Intel(R) VT-d [Disabled]

Allows you to enable/disable Intel® VT-d.

Configuration options: [Enabled] [Disabled]



The following item appears only when you set Intel(R) VT-d to [Enabled].

Coherency Support [Disabled]

Allows you to enable/disable VT-d Engine Coherency support.

Configuration options: [Disabled] [Enabled]

ATS Support [Disabled]

Allows you to enable/disable the VT-d Engine address translation services (ATS) support. Configuration options: [Disabled] [Enabled]

5.4.4 PCH SATA Configuration

Aptio Setup Utility - Copyright (C) 2011 American Megatrends, Inc.

Advanced

SATA Port1	Not Present	(1) IDE Mode. (2) AHCI Mode. (3) RAID Mode.
SATA Port2	ASUS DWR ATAPI	
SATA Port3	WDC WD800JD (80.0GB)	
SATA Port4	Not Present	
SATA Port5	Not Present	
SATA Port6	Not Present	
SATA Mode	[AHCI Mode]	→←: Select Screen ↑↓: Select Item Enter: Select Item +/-: Change Opt. F1: General Help F2: Previous Values F5: Optimized Defaults F10: Save & Exit ESC: Exit
SATA Controller 1	[Enhanced]	
SATA Controller 2	[Enhanced]	
S.M.A.R.T. Status Check	[Enabled]	
Port 1 Staggered Spin-up	[Disabled]	
Port 2 Staggered Spin-up	[Disabled]	
Port 3 Staggered Spin-up	[Disabled]	
Port 4 Staggered Spin-up	[Disabled]	
Port 5 Staggered Spin-up	[Disabled]	
Port 6 Staggered Spin-up	[Disabled]	

Version 2.15.1219. Copyright (C) 2011 American Megatrends, Inc.

SATA Mode [AHCI Mode]

Allows you to set the SATA configuration.

Configuration options: [Disabled] [IDE Mode] [AHCI Mode] [RAID Mode]



- If you want to use the Serial ATA hard disk drives as Parallel ATA physical storage devices, set this item to [IDE Mode].
- If you want the Serial ATA hard disk drives to use the Advanced Host Controller Interface (AHCI), keep the default setting [AHCI Mode]. The AHCI allows the onboard storage driver to enable advanced Serial ATA features that increases storage performance on random workloads by allowing the drive to internally optimize the order of commands.
- If you want to create RAID sets with LSI MegaRAID utility, or Intel® Rapid Storage Technology Enterprise from the Serial ATA hard disk drives, set this item to [RAID Mode].

SATA Controller 1 [Enhanced]

This item appears only when you set the SATA Mode item to [IDE Mode]. Set to [Enhanced] to support two SATA 6.0 Gb/s and two SATA 3.0 Gb/s devices. Set to [Compatible] when using Windows 98/NT/2000/MS-DOS. Up to four SATA devices are supported under these operating systems.

Configuration options: [Disabled] [Enhanced] [Compatible]

SATA Controller 2 [Enhanced]

This item appears only when you set the SATA Mode item to [IDE Mode]. Set to [Enhanced] to support two SATA 3.0 Gb/s devices.

Configuration options: [Disabled] [Enhanced]

S.M.A.R.T. Status Check [Enabled]

S.M.A.R.T. (Self-Monitoring, Analysis and Reporting Technology) is a monitor system. When read/write of your hard disk errors occur, this feature allows the hard disk to report warning messages during POST.

Configuration options: [Enabled] [Disabled]

Staggered Spin-up [Disabled]

Staggered spin-up is a feature defined in the Serial ATA Specifications. It enables an HBA to individually spin-up attached SATA devices to avoid maximum current charged by applying all attached SATA devices at the same time.

Configuration options: [Disabled] [Enabled]

5.4.5 PCH SCU Configuration

Advanced	
Device1 Intel ISR10a Device2 Intel ISR10a Device3 Intel ISR10a Device4 Intel ISR10a Device5 Intel ISR10a Device6 Intel ISR10a Device7 Intel ISR10a Device8 Intel ISR10a Sata only RAID5 [Disabled]	Patsburg B/D sku only →←: Select Screen ↑↓: Select Item Enter: Select Item +/-: Change Opt. F1: General Help F2: Previous Values F5: Optimized Defaults F10: Save & Exit ESC: Exit
Version 2.15.1219. Copyright (C) 2011 American Megatrends, Inc.	

5.4.6 PCI Subsystem Settings

Advanced	
PCI Bus Driver Version V 2.05.00 PCI Option ROM Handling PCI ROM Priority [EFI Compatible ROM] PCI 64bit Resources Handling Above 4G Decoding [Disabled] PCI Common Setting PCI Latency Timer [32 PCI Bus Clocks] VGA Palette Snoop [Disabled] PERR# Generation [Disabled] SERR# Generation [Disabled] Load RT32 Image [Enabled] ▶ PCI Express Settings ▶ PCIe Slot Option Rom Configuration	In case of multiple Option ROMs (Legacy and EFI Compatible), specifies what PCI option ROM to lanuch. →←: Select Screen ↑↓: Select Item Enter: Select Item +/-: Change Opt. F1: General Help F2: Previous Values F5: Optimized Defaults F10: Save & Exit ESC: Exit
Version 2.15.1219. Copyright (C) 2011 American Megatrends, Inc.	

PCI ROM Priority [EFI Compatible ROM]

In case of multiple option roms (Legacy and EFI Compatible), specifies what PCI option rom to launch. Configuration options: [Legacy ROM] [EFI Compatible ROM]

PCI Latency Timer [32 PCI Bus Clocks]

Value to be programmed into PCI latency timer register.

Configuration options: [32 PCI Bus Clocks] [64 PCI Bus Clocks] [96 PCI Bus Clocks] [128 PCI Bus Clocks] [160 PCI Bus Clocks] [192 PCI Bus Clocks] [224 PCI Bus Clocks] [248 PCI Bus Clocks]

VGA Palette Snoop [Disabled]

Allows you to enable/disable the VGA palette registers snooping.

Configuration options: [Disabled] [Enabled]

PERR# Generation [Disabled]

Allows you to enable/disable the PCI device to generate PERR#.

Configuration options: [Disabled] [Enabled]

SERR# Generation [Disabled]

Allows you to enable/disable the PCI device to generate SERR#.

Configuration options: [Disabled] [Enabled]

Load RT32 Image [Enabled]

Allows you to enable/disable RT32 Image Loading.

Configuration options: [Disabled] [Enabled]

PCI Express Settings

Aptio Setup Utility - Copyright (C) 2011 American Megatrends, Inc.	
Advanced	
PCI Express Link Register Settings ASPM Support [Disabled] WARNING: Enabling ASPM may cause some PCI-E device to fail	Allows you to enable or disable PCI Express Device Relaxed Ordering. →←: Select Screen ↑↓: Select Item Enter: Select Item +/-: Change Opt. F1: General Help F2: Previous Values F5: Optimized Defaults F10: Save & Exit ESC: Exit
Version 2.15.1219. Copyright (C) 2011 American Megatrends, Inc.	

PCI Express Link Register Settings

ASPM Support [Disabled]

Allows you to set the ASPM level.

Configuration options: [Disabled] [Auto] [Force L0s]

[Force L0s] Force all links to L0s state.

[Auto] BIOS auto configure.

[Disabled] Disabled ASPM.

PCIe Slot Option Rom Configuration

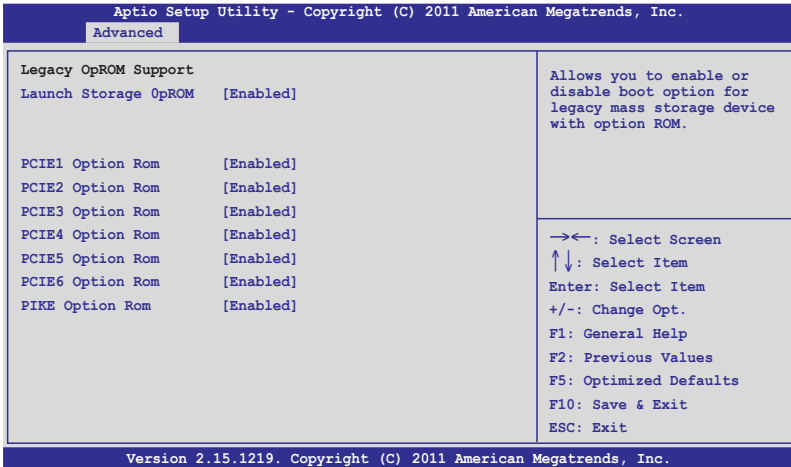

Launch Storage OpROM [Enabled]

Allows you to enable or disable boot option for legacy mass storage device with option ROM. Configuration options: [Disabled] [Enabled]

PCI E1 Option Rom [Enabled]

Configuration options: [Disabled] [Enabled]

PCI E2 Option Rom [Enabled]

Configuration options: [Disabled] [Enabled]

PCI E3 Option Rom [Enabled]

Configuration options: [Disabled] [Enabled]

PCI E4 Option Rom [Enabled]

Configuration options: [Disabled] [Enabled]

PCI E5 Option Rom [Enabled]

Configuration options: [Disabled] [Enabled]

PCI E6 Option Rom [Enabled]

Configuration options: [Disabled] [Enabled]

PIKE Option Rom [Enabled]

Configuration options: [Disabled] [Enabled]

5.4.7 Onboard LAN Configuration

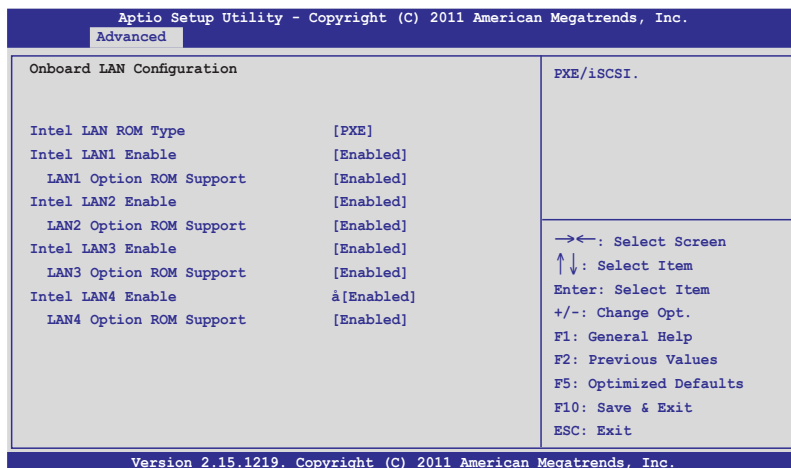

Intel LAN ROM Type [PXE]

Configuration options: [PXE] [iSCSI]



The following item appears only when you set Intel LAN Support to [Enabled].

Intel LAN1 Enable [Enabled]

Allows you to enable or disable Intel® LAN1 function. Configuration options: [Disabled] [Enabled]

LAN1 Option ROM Support [Enabled]

Configuration options: [Disabled] [Enabled]

Intel LAN2 Enable [Enabled]

Allows you to enable or disable Intel® LAN2 function. Configuration options: [Disabled] [Enabled]

LAN2 Option ROM Support [Enabled]

Configuration options: [Disabled] [Enabled]

Intel LAN3 Enable [Enabled] (Z9PE-D16 only)

Allows you to enable or disable Intel® LAN3 function.

Configuration options: [Disabled] [Enabled]

LAN3 Option ROM Support [Enabled] (Z9PE-D16 only)

Configuration options: [Disabled] [Enabled]

Intel LAN4 Enable [Enabled] (Z9PE-D16 only)

Allows you to enable or disable Intel® LAN4 function.

Configuration options: [Disabled] [Enabled]

LAN4 Option ROM Support [Enabled] (Z9PE-D16 only)

Configuration options: [Disabled] [Enabled]

5.4.8 Intel TXT(LT-SX) Configuration

The Intel® TXT(LT-SX) configuration automatically detects and displays the Intel®TXT(LT-SX) hardware support.

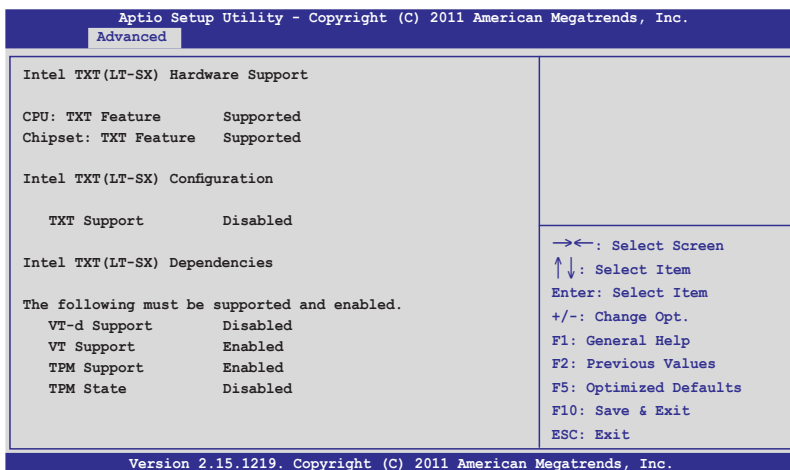

5.4.9 USB Configuration

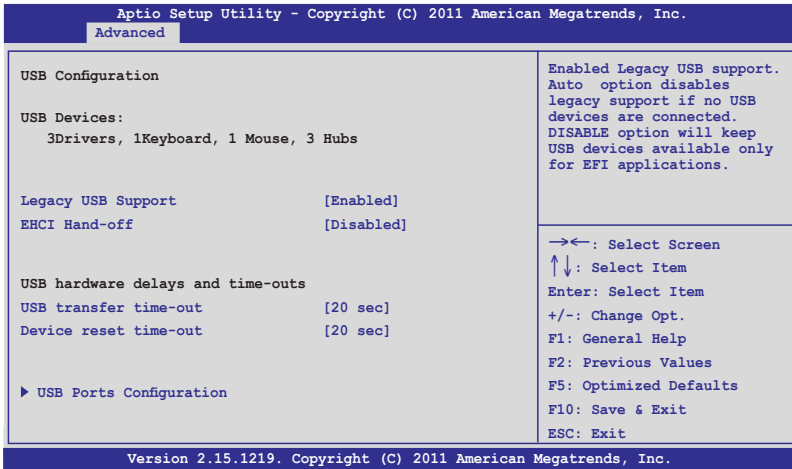

Legacy USB Support [Enabled]

Allows you to enable or disable Legacy USB device support.

Configuration options: [Enabled] [Disabled] [Auto]

EHCI Hand-off [Disabled]

This is a workaround for Oses without EHCI. Ownership change should be claimed by EHCI driver. Configuration options: [Disabled] [Enabled]

USB hardware delays and time-outs

USB transfer time-out [20 sec]

The time-out value for control, bulk, and interrupt transfer.

Configuration options: [1 sec] [5 sec] [10 sec] [20 sec]

Device reset time-out [20 sec]

USB mass storage device start unit command time-out.

Configuration options: [10 sec] [20 sec] [30 sec] [40 sec]

USB Ports Configuration

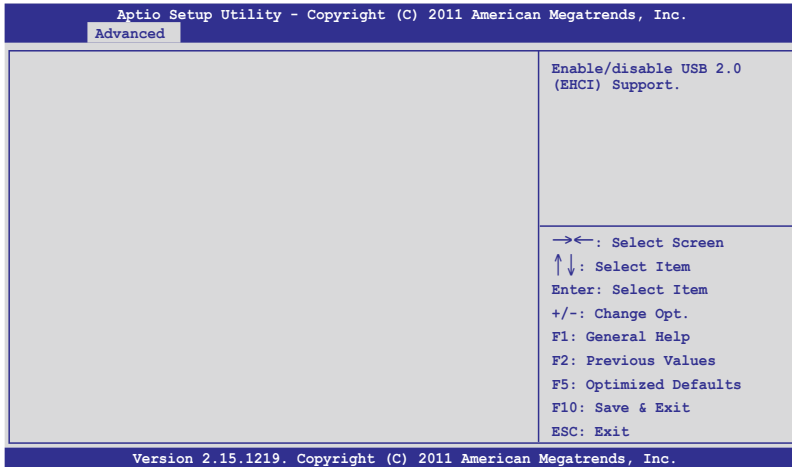

EHCI Controller 1/2 [Enabled]

Allows you to enable or disable USB (EHCI) Support.

Configuration options: [Disabled] [Enabled]

Rear USB #1 and #2 [Enabled]

Allows you to enable or disable rear USB #1 and #2.

Configuration options: [Disabled] [Enabled]

Onboard USB #3/#4/#5/#6/#10 [Enabled]

Allows you to enable or disable Onboard USB #3 / #4 / #5 / #6 / #10.

Configuration options: [Disabled] [Enabled]

5.4.10 Trusted Computing

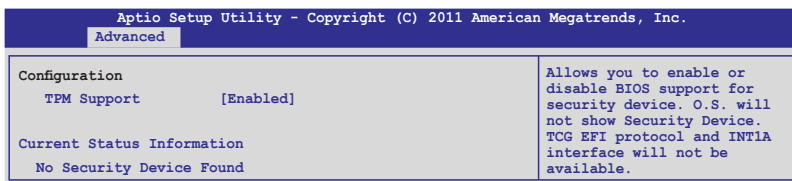

TPM Support [Enabled]

Allows you to enable or disable the TPM support.

Configuration options: [Disabled] [Enabled]

5.4.11 ACPI Settings

Aptio Setup Utility - Copyright (C) 2011 American Megatrends, Inc.		
Advanced		
ACPI Settings		Allows you to enable or disable BIOS ACPI Auto Configuration.
Enable ACPI Auto Configuration	[Disabled]	
Enabled Hibernation	[Enabled]	
ACPI Sleep State	[S1 (CPU Stop Clock)]	
Lock Legacy Resources	[Disabled]	

Enable ACPI Auto Configuration [Disabled]

Allows you to enable or disable BIOS ACPI Auto Configuration.

Configuration options: [Disabled] [Enabled]



The following item appears only when you set Enabled ACPI Auto Configuration to [Disabled].

Enable Hibernation [Enabled]

Allows you to enable or disable system ability to Hibernate (OS/S4 sleep state). This option may be not effective with some OS.

Configuration options: [Disabled] [Enabled]

ACPI Sleep State [S1 (CPU Stop Clock)]

Allows you to set the ACPI Sleep State.

Configuration options: [Suspend Disabled] [S1 (CPU Stop Clock)] [S3 (Suspend to RAM)]

Lock Legacy Resources [Disabled]

Allows you to enable or disable Lock Legacy Resources.

Configuration options: [Disabled] [Enabled]

5.4.12 WHEA Configuration

Aptio Setup Utility - Copyright (C) 2011 American Megatrends, Inc.	
Advanced	
WHEA Support [Enabled]	Enable or disable Windows Hardware Error Architecture.

WHEA Support [Enabled]

Allows you to enable or disable the Windows Hardware Error Architecture support.
Configuration options: [Disabled] [Enabled]

5.4.13 APM setting

Aptio Setup Utility - Copyright (C) 2011 American Megatrends, Inc.	
Advanced	
Restore AC Power Loss [Last State]	Specify what state to go to when power is re-applied after a power failure (G3 state).
Power On By PCIE [Disabled]	
Power On By RTC [Disabled]	

Restore AC Power Loss [Last State]

When set to [Power Off], the system goes into off state after an AC power loss. When set to [Power On], the system will reboot after an AC power loss. When set to [Last State], the system goes into either off or on state, whatever the system state was before the AC power loss. Configuration options: [Power Off] [Power On] [Last State]

Power On By PCIE [Disabled]

[Disabled] Disables the PCIE devices to generate a wake event.
[Enabled] Enables the PCIE devices to generate a wake event.

Power On By RTC [Disabled]

[Disabled] Disables RTC to generate a wake event.
[Enabled] When set to [Enabled], the items RTC Alarm Date (Days) and Hour/Minute/Second will become user-configurable with set values.

5.4.14 Serial Port Console Redirection

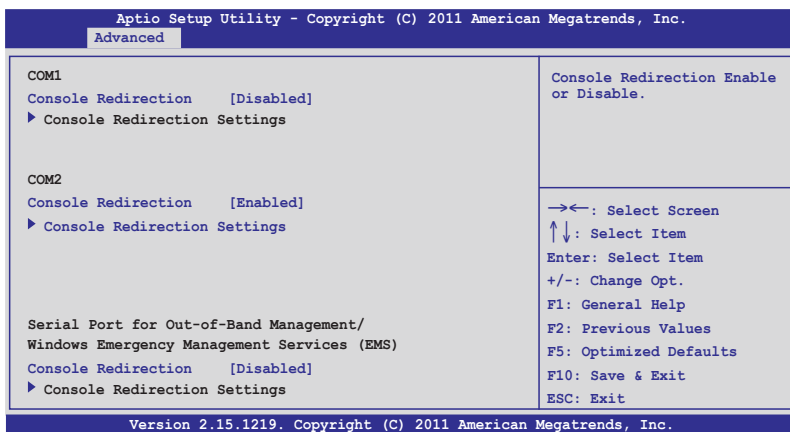

COM1

Console Redirection [Disabled]

Allows you to enable or disable the console redirection feature.

Configuration options: [Disabled] [Enabled]



The following item appears only when you set Console Redirection to [Enabled].

Console Redirection Settings

This item becomes configurable only when you enable the Console Redirection item. The settings specify how the host computer and the remote computer (which the user is using) will exchange data. Both computers should have the same or compatible settings.

Terminal Type [VT-UTF8]

Allows you to set the terminal type.

[VT100] ASCII char set.

[VT100+] Extends VT100 to support color, function keys, et.

[VT-UTF8] Uses UTF8 encoding to map Unicode chars onto 1 or more bytes

[ANSI] Extended ASCII char set

Bits per second [57600]

Selects serial port transmission speed. The speed must be matched on the other side. Long or noisy lines may require lower speeds.

Configuration options: [9600] [19200] [38400] [57600] [115200]

Data Bits [8]

Configuration options: [7] [8]

Parity [None]

A parity bit can be sent with the data bits to detect some transmission errors. [Mark] and [Space] parity do not allow for error detection.

[None] None

[Even] parity bit is 0 if the num of 1's in the data bits is even

[Odd] parity bit is 0 if num of 1's in the data bits is odd

[Mark] parity bit is always 1

[Space] parity bit is always 0

Stop Bits [1]

Stop bits indicate the end of a serial data packet. (A start bit indicates the beginning.) The standard setting is 1 stop bit. Communication with slow devices may require more than 1 stop bit. Configuration options: [1] [2]

Flow Control [Hardware RTS/CTS]

Flow control can prevent data loss from buffer overflow. When sending data, if the receiving buffers are full, a "stop" signal can be sent to stop the data flow. Once the buffers are empty, a "start" signal can be sent to re-start the flow. Hardware flow control uses two wires to send start/stop signals.

Configuration options: [None] [Hardware RTS/CTS]

Recorder Mode [Disabled]

With this mode enabled only text will be sent. This is to capture Terminal data. Configuration options: [Disabled] [Enabled]

Recorder 100x31 [Disabled]

Allows you to enable or disable extend terminal resolution.

Configuration options: [Disabled] [Enabled]

Legacy OS Redirection Resolution [80x24]

Configures the number of rows and columns supported on legacy OS.

Configuration options: [80x24] [80x25]

COM2

Console Redirection [Enabled]

Allows you to enable/disable the console redirection feature.

Configuration options: [Disabled] [Enabled]

Console Redirection Settings

Please refer to the description of the Console Redirection Settings item under COM1 for details.

Serial Port for Out-of-Band Management/

Windows Emergency Management Services (EMS)

Console Redirection [Disabled]

Allows you to enable/disable the console redirection feature.

Configuration options: [Disabled] [Enabled]



The following item appears only when you set Console Redirection to [Enabled]

Console Redirection Settings

Out-of-Band Mgmt Port [COM1]

Microsoft Windows Emergency Management Services (EMS) allows the remote management of a Windows Server OS through a serial port.

Configuration options: [COM1] [COM2]

Terminal Type [VT-UTF8]

Microsoft Windows Emergency Management Services (EMS) allows the remote management of a Windows Server OS through a serial port.

Configuration options: [VT100] [VT100+] [VT-UTF8] [ANSI]

Bits per second [115200]

Microsoft Windows Emergency Management Services (EMS) allows the remote management of a Windows Server OS through a serial port.

Configuration options: [9600] [19200] [57600] [115200]

Flow Control [None]

Microsoft Windows Emergency Management Services (EMS) allows the remote management of a Windows Server OS through a serial port.

Configuration options: [VT100] [Hardware RTS/CTS] [Software Xon/Xoff]

5.4.15 ME Subsystem

Aptio Setup Utility - Copyright (C) 2011 American Megatrends, Inc.	
Advanced	
<pre> Intel ME Subsystem Configuration ME BIOS Interface Version 1.2 ME Version 2.1.5.64 ME FW Status Value : 0xf0345 ME FW State : SPS ME FW Active ME FW Operation State: M0 without UMA ME FW Error Code: No Error ME Ext FW Status value:0x39006301 BIOS Booting Mode: Performance Optimized Cores Disabled: 0 ME FW SKU Information:SiEn NM </pre>	<pre> ME Subsystem Help. -><-: Select Screen ↑↓: Select Item Enter: Select Item +/-: Change Opt. F1: General Help F2: Previous Values F5: Optimized Defaults F10: Save & Exit ESC: Exit </pre>
Version 2.15.1219. Copyright (C) 2011 American Megatrends, Inc.	

5.4.16 Legacy Devices Configuration

Aptio Setup Utility - Copyright (C) 2011 American Megatrends, Inc.	
Advanced	
<ul style="list-style-type: none"> ▶ Serial Port 1 Configuration ▶ Serial Port 2 Configuration 	Set Parameters of serial Port 1 (COM1).

Serial Port 1/2 Configuration

Aptio Setup Utility - Copyright (C) 2011 American Megatrends, Inc.	
Advanced	
<pre> Serial Port Configuration Serial Port [Enabled] Device Settings I0=3F8h; IRQ=4 Device Mode [Standard Serial Po...] </pre>	Enable or Disable Serial Port (COM).

Serial Port [Enabled]

Allows you to enable or disable the serial port.

Configuration options: [Disabled] [Enabled]

Device Mode [Standard Serial Port Mode]

Allows you to change the serial port mode.

Configuration options: [Standard Serial Port Mode]

5.4.17 Runtime Error Logging

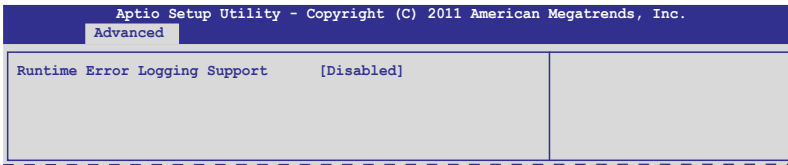

Runtime Error Logging Support [Disabled]

This item allows you to enable or disable Runtime Error Logging Support.

Configuration options: [Disabled] [Enabled]



The following item appears only when you set Runtime Error Logging Support to [Enabled].

PCI Error Logging Support [Disabled]

Allows you to enable or disable PCI Error Logging.

Configuration options: [Disabled] [Enabled].

5.5 Server Mgmt menu

The Server Mgmt menu displays the server mgmt status, and allows you to change the settings.



The Server Mgmt menu appears only when you install ASMB card on the motherboard.

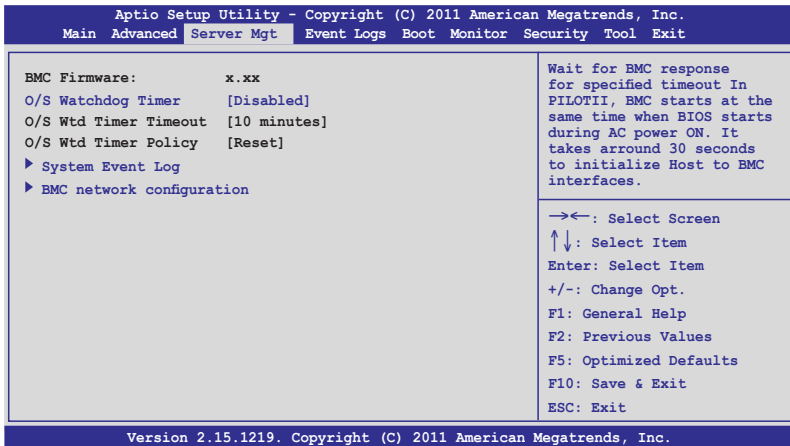

O/S Watchdog Timer [Disabled]

If enabled, this item starts a BIOS timer that can only be shut off by Intel Management Software after the OS loads. It helps determine that the OS is successfully loaded and follows the O/S Boot Watchdog Timer Policy.

Configuration options: [Enabled] [Disabled]



The following two items appear only when you set O/S Watchdog Timer to [Enabled].

O/S Wtd Timer Timeout [10 minutes]

Allows you to configure the duration of the O/S Boot Watchdog Timer.

Configuration options: [5 minutes] [10 minutes] [15 minutes] [20 minutes]

O/S Wtd Timer Policy [Reset]

Allows you to configure how the system should respond if the OS Boot Watchdog Timer expires.

Configuration options: [Do Nothing] [Reset] [Power Down]

5.5.1 System Event Log

Aptio Setup Utility - Copyright (C) 2011 American Megatrends, Inc.	
Server Mgt	
Enabling/Disabling Options SEL Components [Disabled]	Change this to enable or disable all features of system Event Logging during boot.
Erasing Settings Erase SEL [No] When SEL is Full [Do Nothing]	→←: Select Screen ↑↓: Select Item Enter: Select Item +/-: Change Opt. F1: General Help F2: Previous Values F5: Optimized Defaults F10: Save & Exit ESC: Exit
Note: All values changed here do not take effect until computer is restarted.	
Version 2.15.1219. Copyright (C) 2011 American Megatrends, Inc.	

SEL Components [Disabled]

Allows you to enable/disable all features of system Event Logging during bootup.
Configuration options: [Disabled] [Enabled]



- The following items appears only when you set SEL Components to [Enabled].
- All the changes will take effect after restarting the system after restarting the system.

Erase SEL [No]

Allows you to choose the action in erasing SEL.

Configuration options: [No] [Yes, On next reset] [Yes, On every reset]

When SEL is Full [Do Nothing]

Allows you to choose the action when SEL is full.

Configuration options: [Do Nothing] [Erase Immediately]

5.5.2 BMC network configuration

Aptio Setup Utility - Copyright (C) 2011 American Megatrends, Inc.	
Server Mgt	
BMC network configuration	Select to configure LAN channel parameters statically or dynamically (by BIOS or BMC). Unspecified option will not modify any BMC network parameters during BIOS phase
DM_KAN1	
DM_LAN1 IP Address in BMC:	192.168.001.001
DM_LAN1 Subnet Mask in BMC:	255.255.255.000
DM_LAN1 Gateway Address in BMC	:000.000.000.000
DM_LAN1 MAC Address in BMC:	00.CE.01.87.72.A0
DM_LAN1 Address Source in BMC:	Static Mode
Configuration Address source	[Previous State]
Lan1	
Lan1 IP Address in BMC:	192.168.001.002
Lan1 Subnet Mask in BMC:	255.255.255.000
Lan1 Gateway Address in BMC:	000.000.000.000
Lan1 MAC Address in BMC:	00.CE.01.87.72.A0
Lan1 Address Source in BMC:	Static Mode
Configuration Address source	[Previous State]
→←: Select Screen ↑↓: Select Item Enter: Select Item +/-: Change Opt. F1: General Help F2: Previous Values F5: Optimized Defaults F10: Save & Exit ESC: Exit	
Version 2.15.1219. Copyright (C) 2011 American Megatrends, Inc.	

Configuration Address source [Previous State]

Allows you to select the static or dynamic LAN settings.

Configuration options: [Previous State] [Static Mode] [DHCP Mode]



The following items appear only when you set Configuration Address source to [Static Mode].

Station IP address [0.0.0.0]

Allows you to key in the Station IP address.

Subnet mask [0.0.0.0]

Allows you to key in the Subnet mask.

Gateway IP address [0.0.0.0]

Allows you to key in the Gateway IP address.

5.6 Event Logs menu

The Event Logs menu allows you to change or view the event log settings.

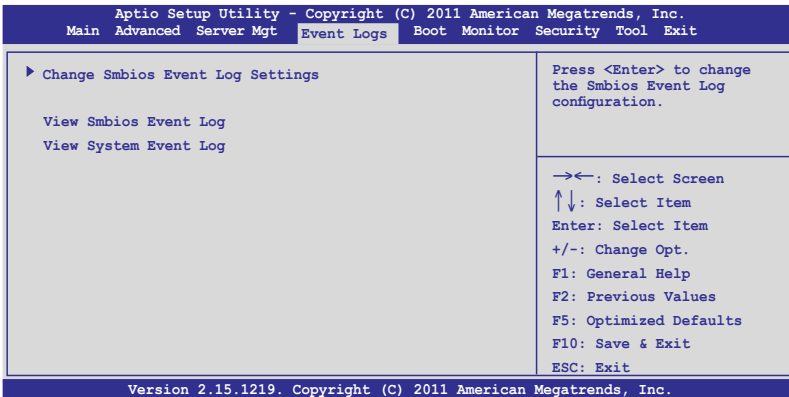

5.6.1 Change Smbios Event Log Settings

Press <Enter> to change the Smbios Event Log configuration.

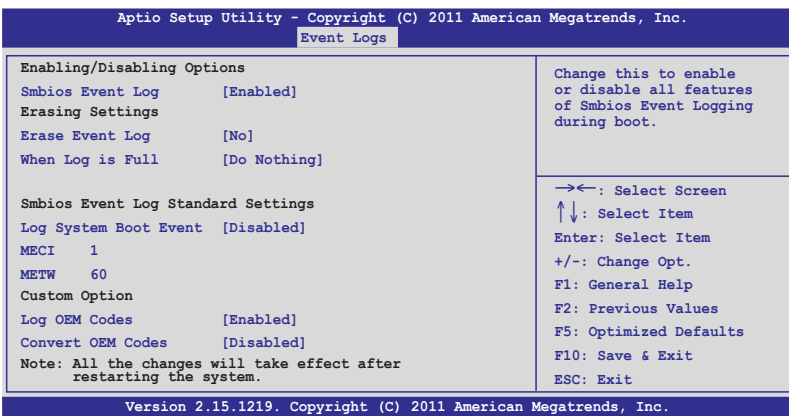

All the changes will take effect after restarting the system.

Enabling/Disabling Options

Smbios Event Log [Enabled]

Allows you to enable/disable all features of Smbios Event Logging during bootup. Configuration options: [Disabled] [Enabled]

Erasing Settings

Erase Event Log [No]

Allows you to select the option in erasing Smbios Event Log. Erasing is done prior to any logging activation during reset.

Configuration options: [No] [Yes, Next reset] [Yes, Every reset]

When Log is Full [Do Nothing]

Allows you to select the action when the Smbios Event Log is full.

Configuration options: [Do Nothing] [Erase Immediately]

Smbios Event Log Standard Settings

Log System Boot Event [Disabled]

Allows you to enable/disable the System boot event log.

Configuration options: [Enabled] [Disabled]

MECI [1]

Multiple Event Count Increment (MECI) is the number of occurrences of a duplicate event that must pass before the multiple-event counter associated with the log entry is updated, specified as a numeric value in the range 1 to 255.

METW [60]

Multiple Event Time Windows (METW) is the number of minutes that must pass between duplicate log entries that utilize a multiple-event counter. The value ranges from 0 to 99 minutes.

Custom Option

Log OEM Codes [Enabled]

Allows you to enable/disable the logging of EFI Status Codes as OEM Codes (if not already converted to legacy).

Configuration options: [Disabled] [Enabled]

Convert OEM Codes [Disabled]

Enable or disable the converting of EFI Status Codes to Standard Smbios Types (Not all may be translated). Configuration options: [Disabled] [Enabled]

View Smbios Event Log

Press <Enter> to view all smbios event logs.

View System Event Log

Press <Enter> to view all system event logs.

5.7 Boot menu

The Boot menu items allow you to change the system boot options.

Aptio Setup Utility - Copyright (C) 2011 American Megatrends, Inc.		
Main Advanced Server Mgt Event Logs Boot Monitor Security Tool Exit		
Boot Configuration		Number of seconds to wait for setup activation key. 65535 (0xFFFF) means indefinite waiting.
Setup Prompt Timeout	1	
Bootup NumLock State	[On]	
Full Screen Logo	[Enabled]	
CSM16 Module Version	07.67	
GateA20 Active	[Upon Request]	
Option ROM Messages	[Force BIOS]	
Interrupt 19 Capture	[Enabled]	
Boot Device Seeking	[Endless PXE]	
UEFI Boot	[Disabled]	
Boot Option Priorities		→←: Select Screen ↑↓: Select Item Enter: Select Item +/-: Change Opt. F1: General Help F2: Previous Values F5: Optimized Defaults F10: Save & Exit ESC: Exit
Boot Option #1	[SATA P2: ASUS ...]	
Boot Option #2	[SATA P3: WDC WD80...]	
Boot Option #3	[AMI Virtual Floppy...]	
Boot Option #4	[IBA GE Slot 0700 v...]	
CD/DVD ROM Drive BBS Priorities		
Hard Drive BBS Priorities		
Floppy Drive BBS Priorities		
Network Device BBS Priorities		

Version 2.15.1219. Copyright (C) 2011 American Megatrends, Inc.

Setup Prompt Timeout [xx]

Use the <+> and <-> keys to adjust the number of seconds to wait for setup activation key.

Bootup NumLock State [On]

Allows you to select the power-on state for the NumLock.

Configuration options: [Off] [On]

Full Screen Logo [Enabled]

Allows you to enable or disable the full screen logo display feature.

Configuration options: [Disabled] [Enabled]



Set this item to [Enabled] to use the ASUS MyLogo2™ feature.

GateA20 Active [Upon Request]

[Upon Request] GA20 can be disabled using BIOS services.

[Always] Does not allow disabling GA20. This option useful when any RT code is executed above 1MB.

Option ROM Messages [Force BIOS]

Allows you to set the display mode for Options ROM.

Configuration options: [Force BIOS] [Keep Current]

Interrupt 19 Capture [Enabled]

Allows you to enable/disable the Interrupt 19 Capture function.

Configuration options: [Disabled] [Enabled]

Boot Device Seeking [Endless PXE]

[Endless PXE] Continuous search for the remote boot image until the boot image is until the user presses <Ctrl+Alt+Del> to abort the search.

[Normal] Searches for the remote boot image once then stops.

UEFI Boot [Disabled]

Allows you to enable or disable UEFI Boot.

Configuration options: [Disabled] [Enabled]

Boot Option Priorities

These items specify the boot device priority sequence from the available devices. The number of device items that appears on the screen depends on the number of devices installed in the system.



-
- To select the boot device during system startup, press <F8> when ASUS Logo appears.
 - To access Windows OS in Safe Mode, please press <F8> after POST.
-

Set the booting order of network devices.

Boot Option #1/#2/#3/#4 [SATA P2: ASUS ...]

Configuration options: [SATA P2: ASUS ...] [SATA P3: WDC WD80...] [AMI Virtual Floppy...] [IBA GE Slot 0700 v...]

CD/DVD ROM Drive BBS Priorities, Hard Drive BBS Priorities, Floppy Drive BBS Priorities, Network Device BBS Priorities

These items appear only when you connect SATA ODD or hard drive to the SATA ports and allow you to set the booting order of the SATA devices.

5.8 Monitor menu

The Monitor menu displays the system temperature/power status, and allows you to change the fan settings.

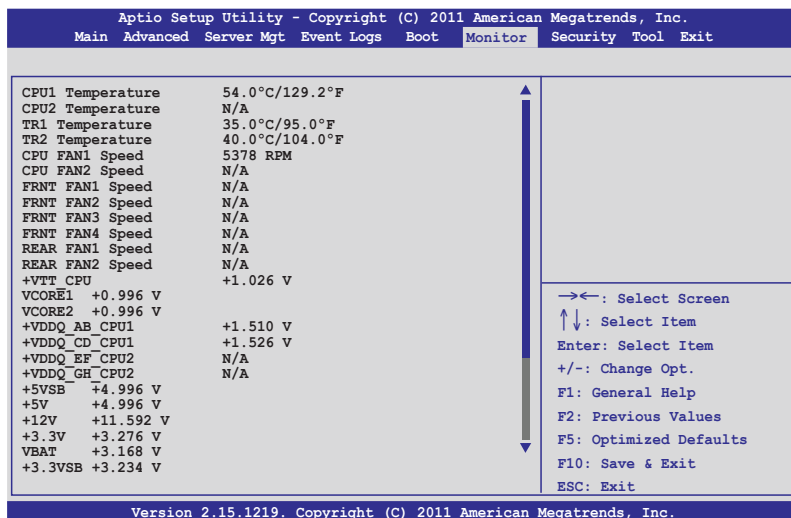

Scroll down to display the following items:

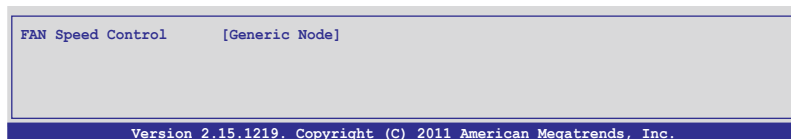

CPU 1/2; TR1 1/2 Temperature [xxx°C/xxx°F]

The onboard hardware monitor automatically detects and displays the CPU and motherboard component temperatures.

CPU FAN1/2 Speed; FRNT FAN1–4 Speed; REAR FAN1/2 Speed [xxxx RPM] or [N/A]

The onboard hardware monitor automatically detects and displays the speed of CPU fans, front fans, and rear fan in rotations per minute (RPM). If the fan is not connected to the motherboard, the field shows N/A.

+VTT_CPU Voltage, VCore1/2 Voltage, +VDDQ_AB_CPU1 Voltage, +VDDQ_CD_CPU1 Voltage, +VDDQ_EF_CPU2 Voltage, +VDDQ_GH_CPU2 Voltage, +5VSB Voltage, +5V Voltage, +12V Voltage, +3.3V Voltage, VBAT Voltage, +3.3VSB Voltage

The onboard hardware monitor automatically detects the voltage output through the onboard voltage regulators.

FAN Speed Control [Generic Mode]

Allows you to configure the ASUS Smart Fan feature that smartly adjusts the fan speeds for more efficient system operation.

Configuration options: [Generic Mode] [High Speed Mode] [Full Speed Mode]

5.9 Security menu

The Security menu items allow you to change the system security settings.

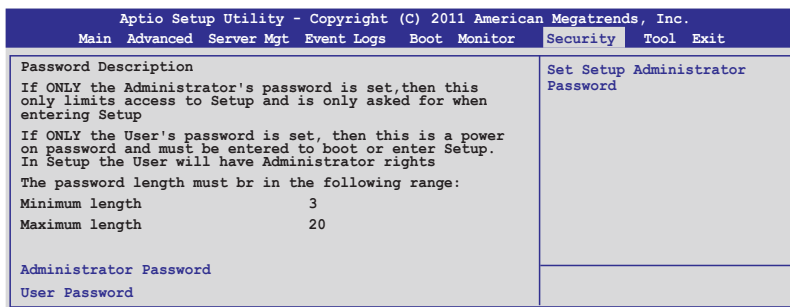

- If you have forgotten your BIOS password, erase the CMOS Real Time Clock (RTC) RAM to clear the BIOS password.
- The Administrator or User Password items on top of the screen show the default **Not Installed**. After you set a password, these items show **Installed**.

Administrator Password

If you have set an administrator password, we recommend that you enter the administrator password for accessing the system. Otherwise, you might be able to see or change only selected fields in the BIOS setup program.

To set an administrator password:

1. Select the **Administrator Password** item and press <Enter>.
2. From the **Create New Password** box, key in a password, then press <Enter>.
3. Confirm the password when prompted.

To change an administrator password:

1. Select the **Administrator Password** item and press <Enter>.
2. From the **Enter Current Password** box, key in the current password, then press <Enter>.
3. From the **Create New Password** box, key in a new password, then press <Enter>.
4. Confirm the password when prompted.

To clear the administrator password, follow the same steps as in changing an administrator password, but press <Enter> when prompted to create/confirm the password. After you clear the password, the Administrator Password item on top of the screen shows Not Installed.

User Password

If you have set a user password, you must enter the user password for accessing the system. The User Password item on top of the screen shows the default Not Installed. After you set a password, this item shows Installed.

To set a user password:

1. Select the **User Password** item and press <Enter>.
2. From the **Create New Password** box, key in a password, then press <Enter>.
3. Confirm the password when prompted.

To change a user password:

1. Select the **User Password** item and press <Enter>.
2. From the **Enter Current Password** box, key in the current password, then press <Enter>.
3. From the **Create New Password** box, key in a new password, then press <Enter>.
4. Confirm the password when prompted.

To clear the user password, follow the same steps as in changing a user password, but press <Enter> when prompted to create/confirm the password. After you clear the password, the User Password item on top of the screen shows Not Installed.

5.10 Tool menu

The Tool menu items allow you to configure options for special functions. Select an item then press <Enter> to display the submenu.

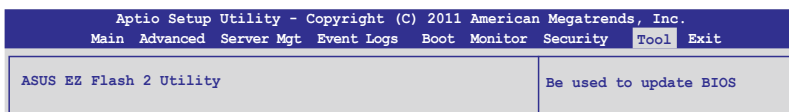

ASUS EZ Flash 2 Utility

Allows you to run ASUS EZ Flash BIOS ROM Utility when you press <Enter>. Check section 5.1.2 ASUS EZ Flash 2 Utility for details.

5.11 Exit menu

The Exit menu items allow you to save or discard your changes to the BIOS items.

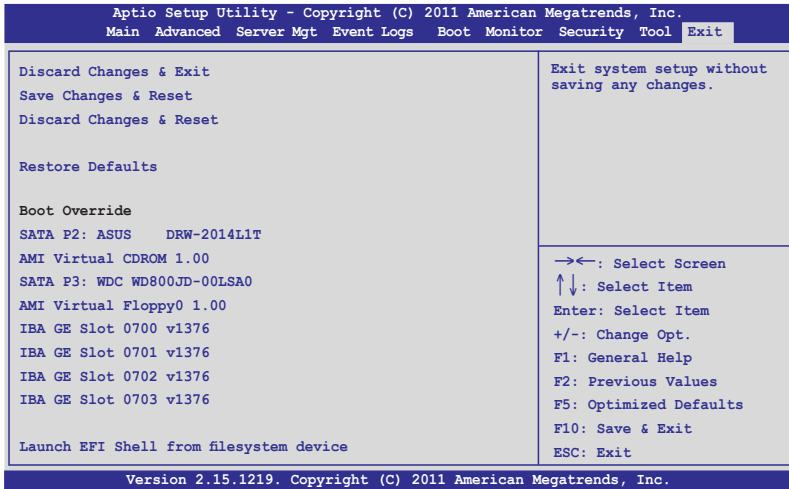

Pressing <Esc> does not immediately exit this menu. Select one of the options from this menu or <F10> from the legend bar to exit.

Boot Override

These items displays the available devices. The device items that appears on the screen depends on the number of devices installed in the system. Click an item to start booting from the selected device.

Launch EFI Shell from filesystem device

Attempts to launch EFI Shell application (shellx64.efi) from one of the available filesystem devices.

Discard Changes & Exit

This option allows you to exit the Setup program without saving your changes. When you select this option or if you press <Esc>, a confirmation window appears. Select Yes to discard changes and exit.

Save Changes & Reset

Once you are finished making your selections, choose this option from the Exit menu to ensure the values you selected are saved. When you select this option or if you press <F10>, a confirmation window appears. Select Yes to save changes and exit.

Discard Changes & Reset

This option allows you to reset the Setup program without saving your changes. When you select this option, a confirmation window appears. Select Yes to discard changes and reset.

Restore Defaults

This option allows you to restore/load defaults values for all the setup options. When you select this option, a confirmation window appears. Select Yes to load optimized defaults.

RAID configuration

6

6.1 Setting up RAID

The motherboard supports the following SATA RAID solutions:

- LSI MegaRAID software RAID Configuration Utility with RAID 0, RAID 1, and RAID 10 support (for both Linux and Windows OS).
- Intel Rapid Storage Technology enterprise SCU / SATA Option ROM Utility with RAID 0, RAID 1, RAID 10, and RAID 5 support (for Windows OS only).

6.1.1 RAID definitions

RAID 0 (Data striping) optimizes two identical hard disk drives to read and write data in parallel, interleaved stacks. Two hard disks perform the same work as a single drive but at a sustained data transfer rate, double that of a single disk alone, thus improving data access and storage. Use of two new identical hard disk drives is required for this setup.

RAID 1 (Data mirroring) copies and maintains an identical image of data from one drive to a second drive. If one drive fails, the disk array management software directs all applications to the surviving drive as it contains a complete copy of the data in the other drive. This RAID configuration provides data protection and increases fault tolerance to the entire system. Use two new drives or use an existing drive and a new drive for this setup. The new drive must be of the same size or larger than the existing drive.

RAID 1E (Enhanced RAID 1) has a striped layout with each stripe unit having a secondary (or alternate) copy stored on a different disk. You can use three or more hard disk drives for this configuration.

RAID 10 is data striping and data mirroring combined without parity (redundancy data) having to be calculated and written. With the RAID 10 configuration you get all the benefits of both RAID 0 and RAID 1 configurations. Use four new hard disk drives or use an existing drive and three new drives for this setup.

RAID 5 stripes both data and parity information across three or more hard disk drives. Among the advantages of RAID 5 configuration include better HDD performance, fault tolerance, and higher storage capacity. The RAID 5 configuration is best suited for transaction processing, relational database applications, enterprise resource planning, and other business systems. Use a minimum of three identical hard disk drives for this setup.



-
- If you want to boot the system from a hard disk drive included in a created RAID set, copy first the RAID driver from the support DVD to a floppy disk before you install an operating system to the selected hard disk drive.
 - Please refer to chapter 4 for how to select the RAID configuration utility. Move the jumper to choose between LSI MegaRAID and Intel® Rapid RAID.
-

6.1.2 Installing hard disk drives

The motherboard supports Serial ATA for RAID set configuration. For optimal performance, install identical drives of the same model and capacity when creating a disk array.

To install the SATA hard disks for RAID configuration:

1. Install the SATA hard disks into the drive bays following the instructions in the system user guide.
2. Connect a SATA signal cable to the signal connector at the back of each drive and to the SATA connector on the motherboard.
3. Connect a SATA power cable to the power connector on each drive.

6.1.3 Setting the RAID item in BIOS

You must set the RAID item in the BIOS Setup before you can create a RAID set from SATA hard disk drives attached to the SATA connectors supported by Intel® C602 chipset. To do this:

1. Enter the BIOS Setup during POST.
2. Go to the **Advanced** menu > **PCH SATA Configuration**, then press <Enter>.
3. Set **SATA Mode** to [RAID Mode]
4. Press <F10> to save your changes and exit the BIOS Setup.



Refer to Chapter 5 for details on entering and navigating through the BIOS Setup.

6.1.4 RAID configuration utilities

Depending on the RAID connectors that you use, you can create a RAID set using the utilities embedded in each RAID controller. For example, use the LSI Logic Embedded SATA RAID Setup Utility or the Intel® Rapid Storage Technology if you installed Serial ATA hard disk drives on the Serial ATA connectors supported by the Intel® C602 chipset.

6.2 LSI Software RAID Configuration Utility

The LSI MegaRAID software RAID configuration utility allows you to create RAID 0, RAID 1, or RAID 10 set from SATA hard disk drives connected to the SATA connectors supported by the motherboard southbridge chip.

To enter the LSI MegaRAID software RAID configuration utility:

1. Turn on the system after installing all the SATA hard disk drives.
2. During POST, the LSI MegaRAID software RAID configuration utility automatically detects the installed SATA hard disk drives and displays any existing RAID set(s). Press <Ctrl> + <M> to enter the utility.

```
LSI MegaRAID Software RAID BIOS Version A.10 09231523R
LSI SATA RAID Found at PCI Bus No:00 Dev No:1F
Device present at Port 0   ST3160812AS   152114MB
Device present at Port 1   ST3160812AS   152114MB
Device present at Port 2   ST3160812AS   152114MB
Device present at Port 3   ST3160812AS   152114MB
Press Ctrl-M or Enter to run LSI Software RAID Setup Utility.
```



- The LSI MegaRAID software RAID configuration utility automatically configures to RAID 1 when the SATA to RAID Mode is enabled.
- The RAID setup screens shown in this section are for reference only and may not exactly match the items on your screen due to the controller version difference.
- When you create RAID sets with the LSI MegaRAID software RAID configuration utility, the boot priority of the SATA optical drive has to be manually adjusted. Otherwise, the system will not boot from the connected SATA ODD.

- The utility main window appears. Use the arrow keys to select an option from the Management Menu and then press <Enter>. Refer to the Management Menu descriptions on the next page.

At the bottom of the screen is the legend box. The keys on the legend box allow you to navigate through the setup menu options or execute commands. The keys on the legend box vary according to the menu level.

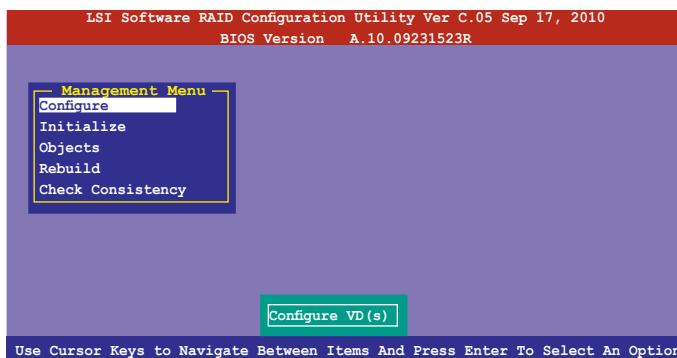

Menu	Description
Configure	Allows you to create RAID 0, RAID 1 or RAID 10 set using the Easy Configuration or the New Configuration command. This menu also allows you to view, add, or clear RAID configurations or select the boot drive
Initialize	Allows you to initialize the virtual drives of a created RAID set
Objects	Allows you to initialize virtual drives or change the virtual drive parameters
Rebuild	Allows you to rebuild failed drives
Check Consistency	Allows you to check the data consistency of the virtual drives of a created RAID set

6.2.1 Creating a RAID set

The LSI Software RAID Configuration Utility allows you to create a RAID 0, RAID 1, or RAID 10 set using two types of configurations: Easy and New.

In Easy Configuration, the virtual drive parameters are set automatically.

In New Configuration, you manually set the virtual drive parameters.

Using Easy Configuration

To create a RAID set using the Easy Configuration option:

1. From the Management Menu, select **Configure** > **Easy Configuration**, and press <Enter>.

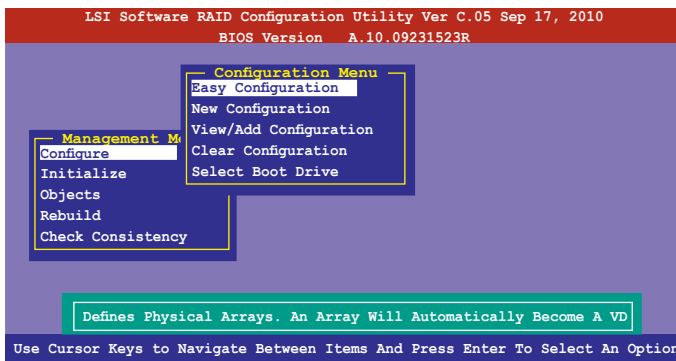

2. The ARRAY SELECTION MENU displays the available drives connected to the SATA ports. Use the up/down arrow keys to select the drives you want to include in the RAID set, and then press <Space>. When selected, the drive indicator changes from READY to ONLIN A[X]-[Y], where X is the array number, and Y is the drive number.

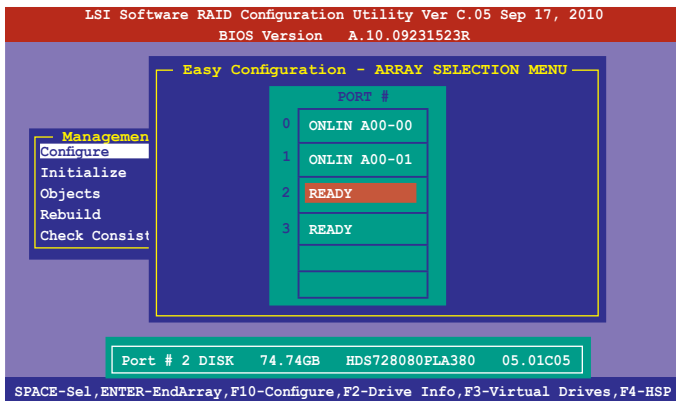



- The information of the selected hard disk drive displays at the bottom of the screen.
- You need at least two identical hard disk drives when creating a RAID 1 set.
- You need at least four identical hard disk drives when creating a RAID 10 set.

3. Select all the drives required for the RAID set, and then press <F10> to configure array setting.
4. Press <Space> to select the configurable array.

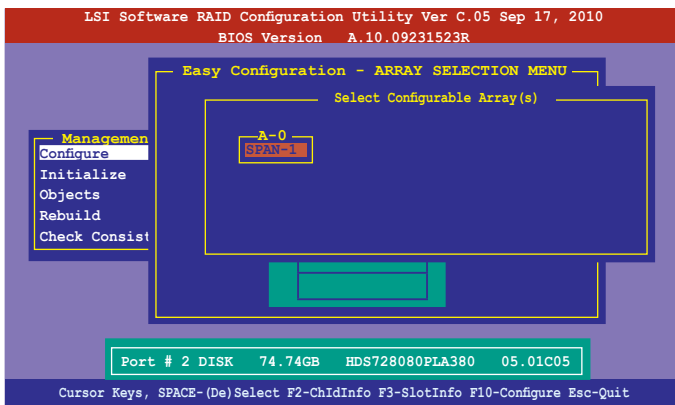

5. Press <F10> again, the virtual drive information appears including a Virtual Drive menu that allows you to change the virtual drive parameters.

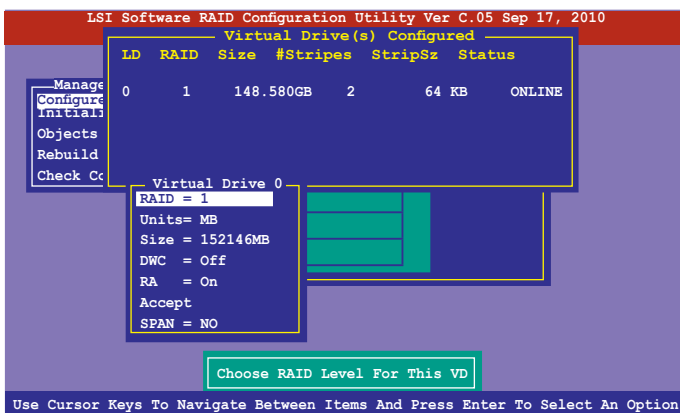

6. Select RAID from the Virtual Drive submenu, and press <Enter>.
7. Select the RAID level from the menu, and then press <Enter>.

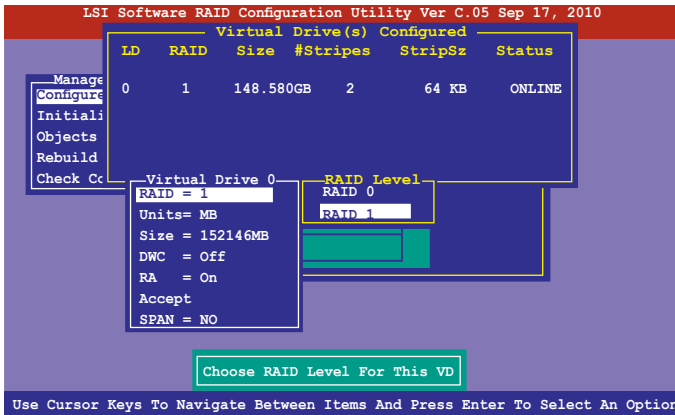

8. Select **Units** from the Virtual Drive submenu, and press <Enter>.
9. Select the units for virtual drive size from the menu, and press <Enter>.

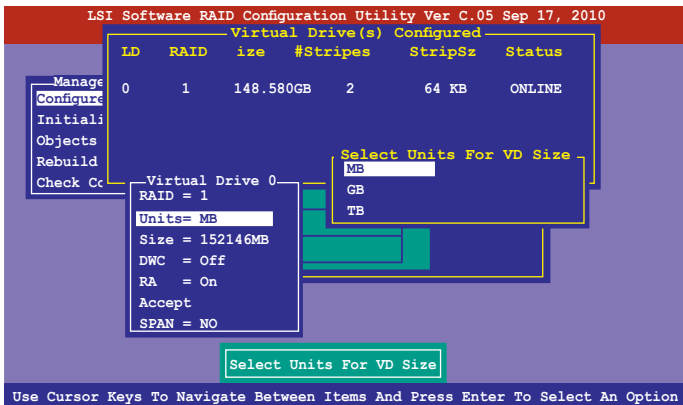

- When creating a RAID 1 or a RAID 10 set, select **DWC** from the Virtual Drive menu, and then press <Enter>.

When creating a RAID 0 set, proceed to step 12.

- Select **On** to enable the Disk Write Cache setting, and press <Enter>.

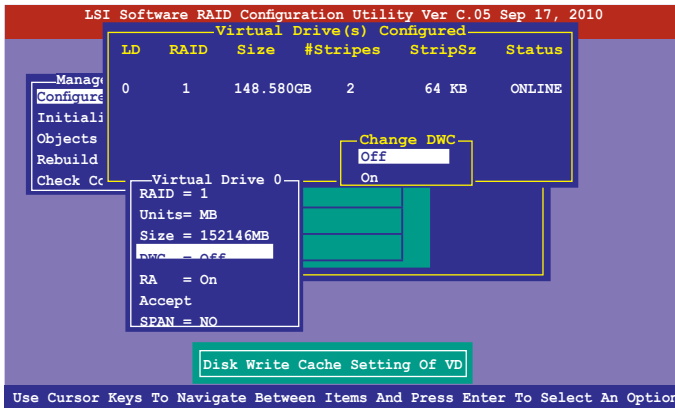

Enabling DWC can improve the performance, but with the risk of data loss.

- When finished setting the selected virtual drive configuration, select **Accept** from the menu, and press <Enter>.

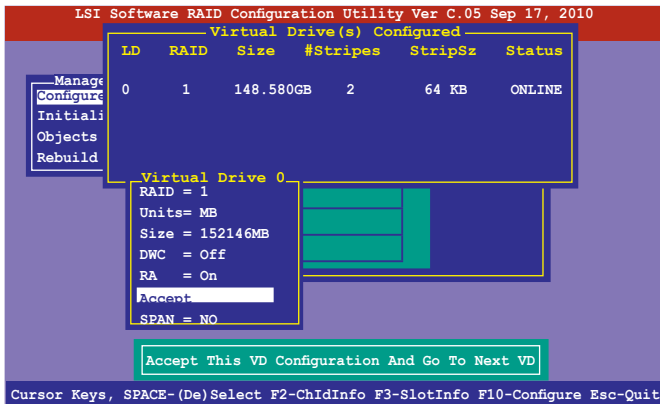

13. Follow steps 2 to 12 to configure additional virtual drives.
14. Press <Esc> to finish RAID configuration. When prompted to save configuration, select **Yes** from the menu, and press <Enter>.

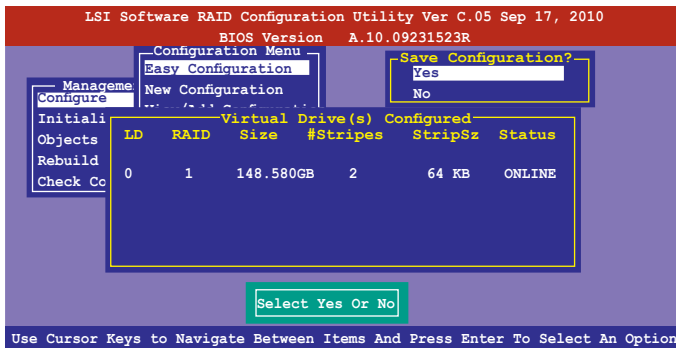

Using New Configuration



When a RAID set already exists, using the New Configuration command erases the existing RAID configuration data. If you do not want to delete the existing RAID set, use the View/Add Configuration command to view or create another RAID configuration.

To create a RAID set using the New Configuration option:

1. From the Management Menu, select **Configure > New Configuration**, and press <Enter>.

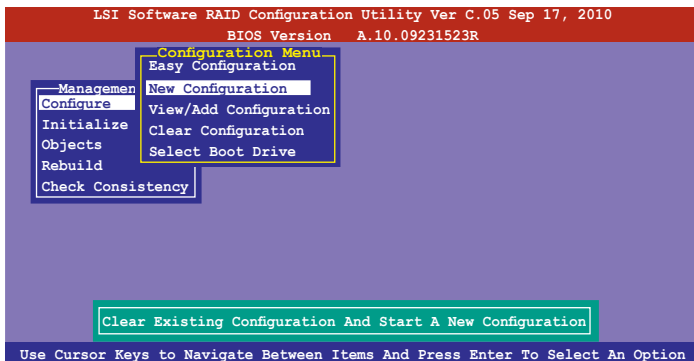

2. Follow steps 2 to 9 of the previous section **Using Easy Configuration**.
3. Select **Size** from the Virtual Drive menu, and then press <Enter>.
4. Key in the desired virtual drive size, and then press <Enter>.

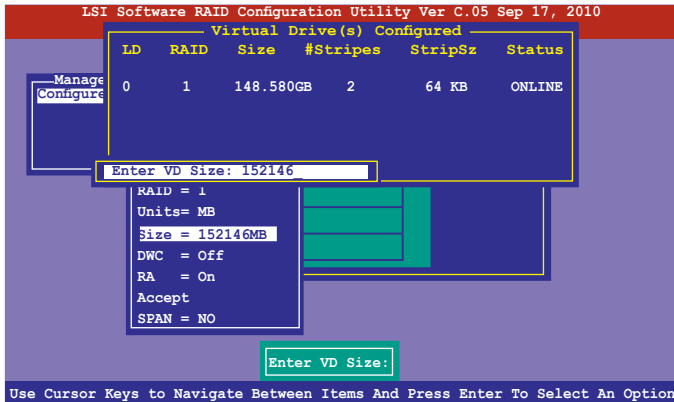

5. Follow step 10 to 14 of the previous section: Using Easy Configuration to create the RAID set.

6.2.2 Adding or viewing a RAID configuration

You can add a new RAID configuration or view an existing configuration using the View/Add Configuration command.

Adding a new RAID configuration

To add a new RAID configuration:

1. From the Management Menu, select **Configure > View/Add Configuration**, and press <Enter>.

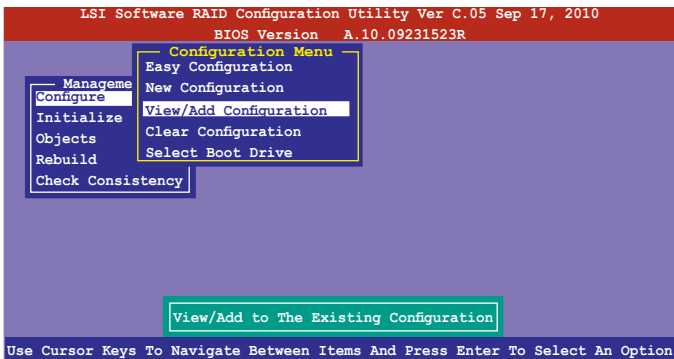

- The ARRAY SELECTION MENU displays the available drives connected to the SATA ports. Select the drive(s) you want to include in the RAID set, then press <Space>. When selected, the drive indicator changes from READY to ONLIN A[X]-[Y], where X is the array number, and Y is the drive number.

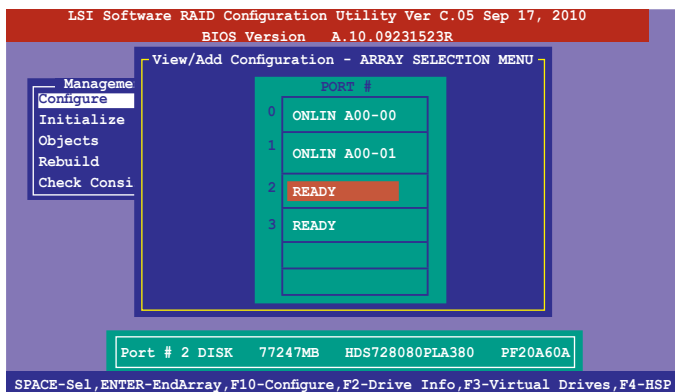

The information of the selected hard disk drive displays at the bottom of the screen.

- Follow steps 3 to 12 of section **6.2.1 Creating a RAID set: Using Easy Configuration** to add a new RAID set.

6.2.3 Initializing the virtual drives

After creating the RAID set(s), you must initialize the virtual drives. You may initialize the virtual drives of a RAID set(s) using the Initialize or Objects command on the Management Menu.

Using the Initialize command

To initialize the virtual drive using the Initialize command:

1. From the Management Menu, select **Initialize**, and press <Enter>.

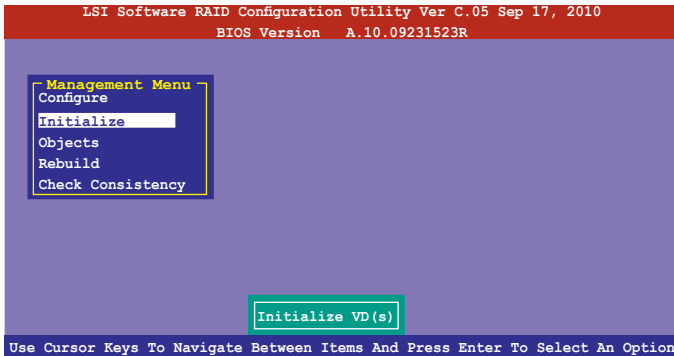

2. The screen displays the available RAID set and prompts you to select the virtual drive to initialize. Use the arrow keys to select the virtual drive from the Virtual Drive selection, and then press <Space>.

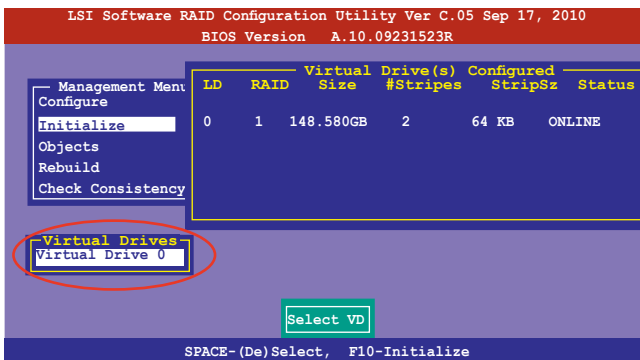

3. Press <F10> to start initialization. When prompted, select **Yes** from the **Initialize?** dialog box, and then press <Enter>.

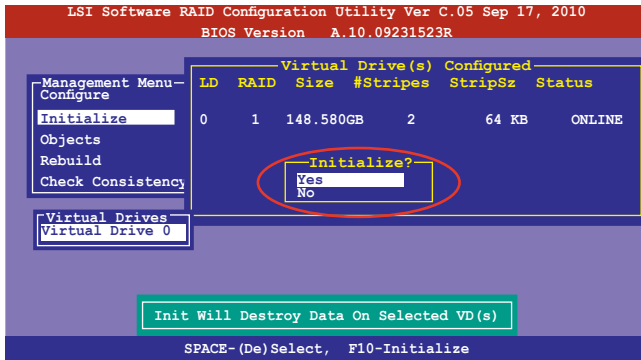

Initializing a virtual drive erases all data on the drive.

4. A progress bar appears on screen. If desired, press <Esc> to abort initialization. When initialization is completed, press <Esc>.

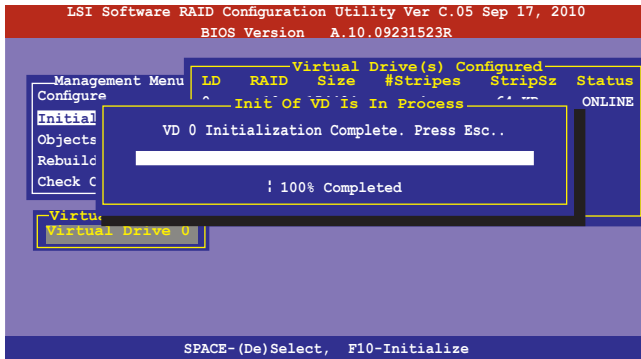

Using the Objects command

To initialize the virtual drives using the Objects command:

1. From the Management Menu, select **Objects > Virtual Drive**, and press <Enter>.

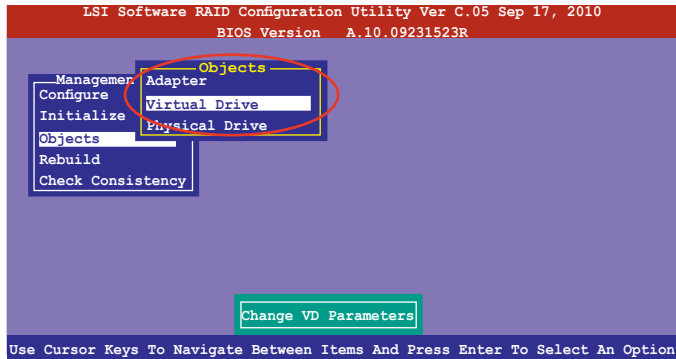

2. Select the virtual drive to initialize from the Virtual Drives submenu, and then press <Enter>.

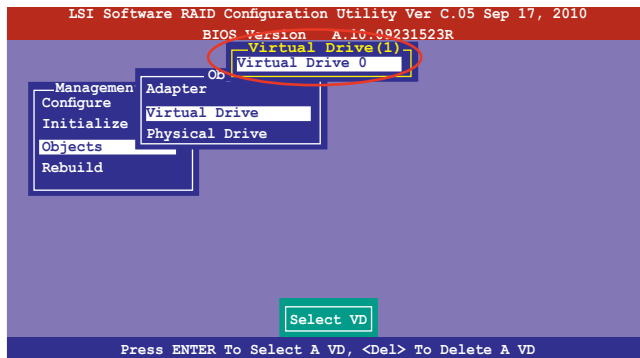

3. Select **Initialize** from the pop-up menu, and then press <Enter> to start initialization.

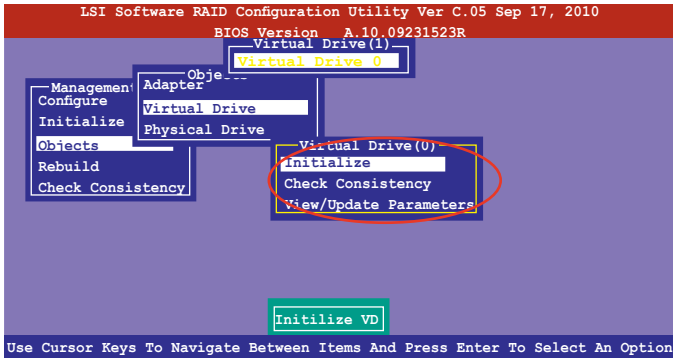

4. When prompted, press the <Space> to select **Yes** from the **Initialize?** dialog box, and press <Enter>.

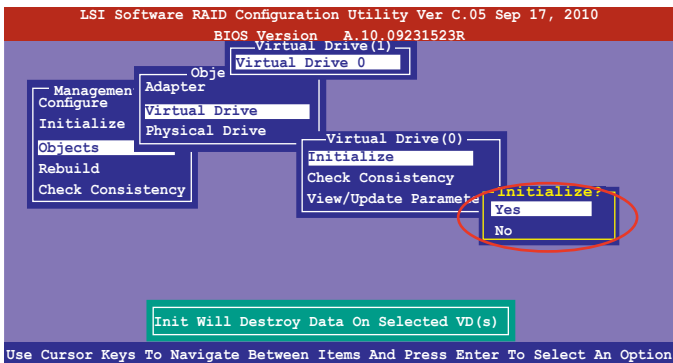

5. A progress bar appears on screen. If desired, press <Esc> to abort the initialization process. When initialization is completed, press <Esc>.

6.2.4 Rebuilding failed drives

You can manually rebuild failed hard disk drives using the **Rebuild** command in the **Management Menu**.

To rebuild a failed hard disk drive

1. From the **Management Menu**, select **Rebuild**, and then press <Enter>.

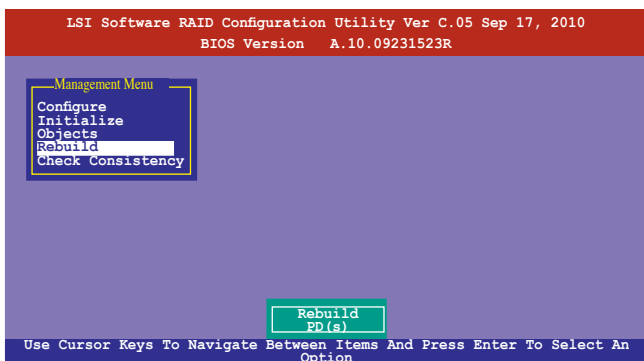

2. The **PHYSICAL DRIVES SELECTION MENU** displays the available drives connected to the SATA ports. Select the drive you want to rebuild, and then press <Space>.

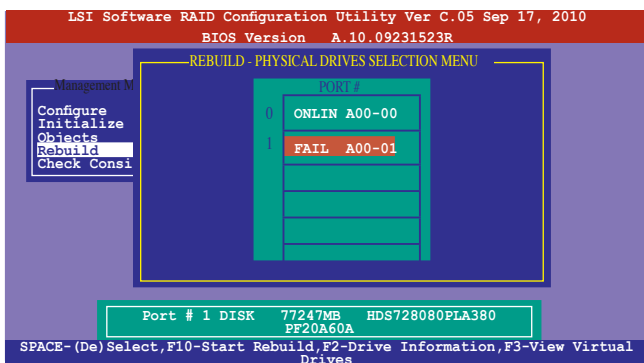

3. After selecting the drive to rebuild, press <F10>. When prompted, press <Y> to rebuild the drive.

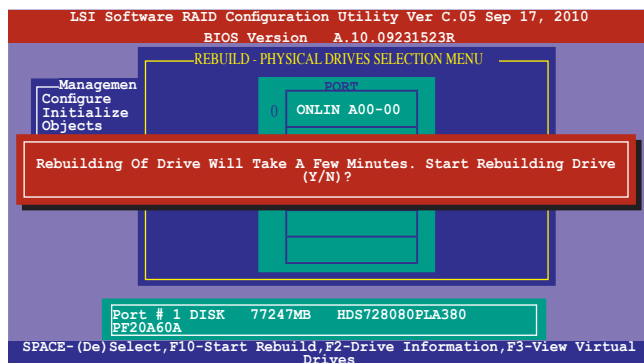

4. When rebuild is complete, press any key to continue.

6.2.5 Checking the drives for data consistency

You can check and verify the accuracy of data redundancy in the selected virtual drive. The utility can automatically detect and/or detect and correct any differences in data redundancy depending on the selected option in the **Objects > Adapter** menu.



The **Check Consistency** command is available only for virtual drives included in a RAID 1 or RAID 10 set.

Using the Check Consistency Command

To check data consistency using the **Check Consistency** command

1. From the **Management Menu**, select **Check Consistency**, and then press <Enter>.

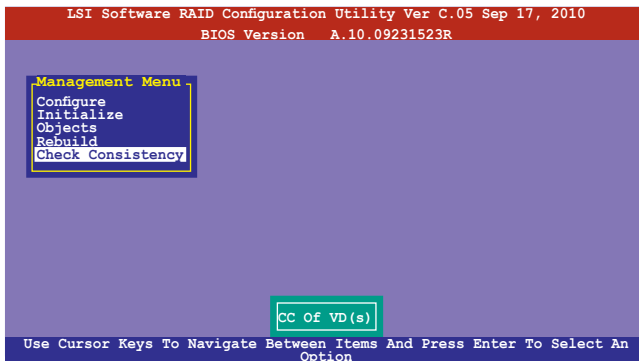

2. The screen displays the available RAID set(s) and prompts you to select the virtual drive to check. Press <Space> to select the virtual drive from the **Virtual Drive** sub-menu, and then press <F10>.

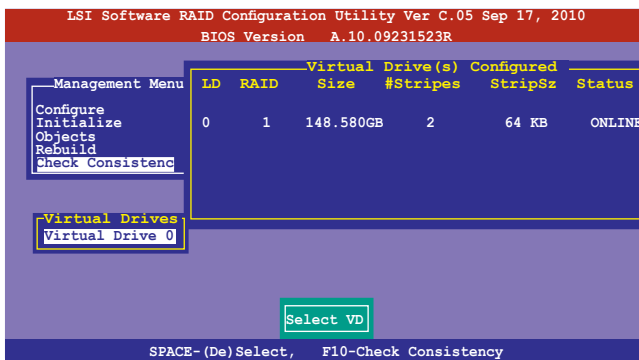

- When prompted, use the arrow keys to select **Yes** from the **Consistency Check?** dialog box, and then press <Enter>.

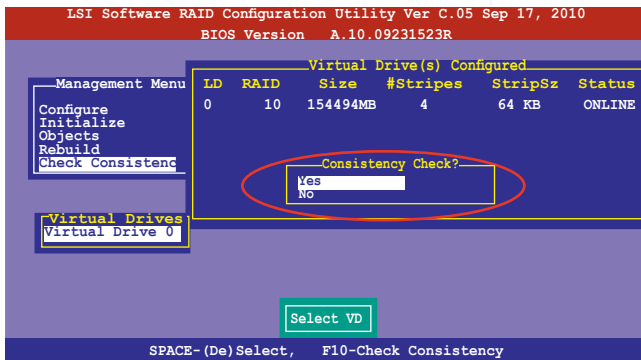

A progress bar appears on screen.

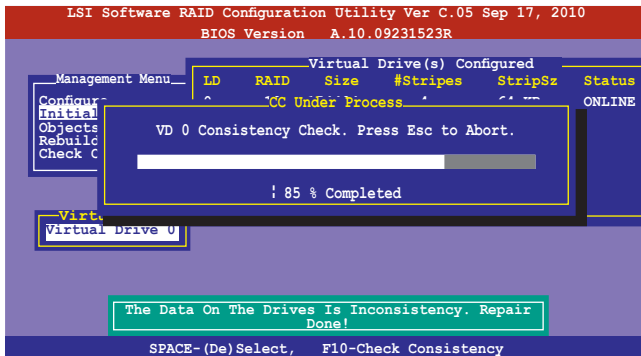

- While checking the disk consistency, press <Esc> to display the following options.
 - Stop** - Stops the consistency check. The utility stores the percentage of disk checked, and when you restart checking, it continues from the last percentage completed rather than from zero percent.
 - Continue** - Continues the consistency check.
 - Abort** - Aborts the consistency check. When you restart checking, it continues from zero percent.
- When checking is complete, press any key to continue.

Using the Objects command

To check data consistency using the **Objects** command

1. From the **Management Menu**, select **Objects**, and then select **Virtual Drive** from the sub-menu.
2. Use the arrow keys to select the virtual drive you want to check, and then press <Enter>.
3. Select **Check Consistency** from the pop-up menu, and then press <Enter>.
4. When prompted, use the arrow keys to select **Yes** from the dialog box to check the drive.
5. When checking is complete, press any key to continue.

6.2.6 Deleting a RAID configuration

To delete a RAID configuration

1. From the **Management Menu**, select **Configure > Clear Configuration**, and then press <Enter>.

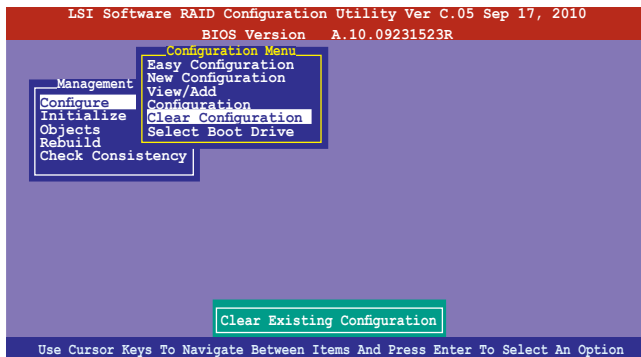

2. When prompted, use the arrow keys to select **Yes** from the **Clear Configuration?** dialog box, and then press <Enter>.

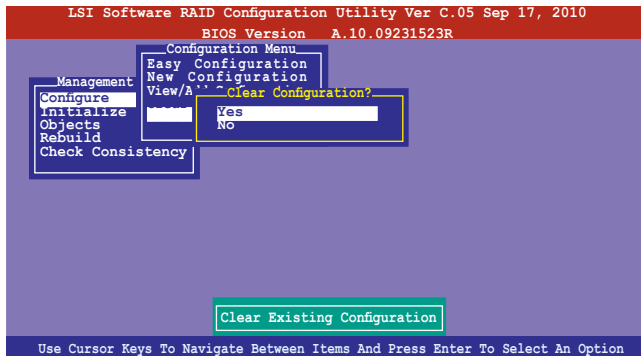

The utility clears all the current array(s).

3. Press any key to continue.

6.2.7 Selecting the boot drive from a RAID set

You must have created a new RAID configuration before you can select the boot drive from a RAID set. See section 5.2.1 **Creating a RAID set: Using New Configuration** for details.

To select the boot drive from a RAID set

1. From the **Management Menu**, select **Configure > Select Boot Drive**, and then press <Enter>.

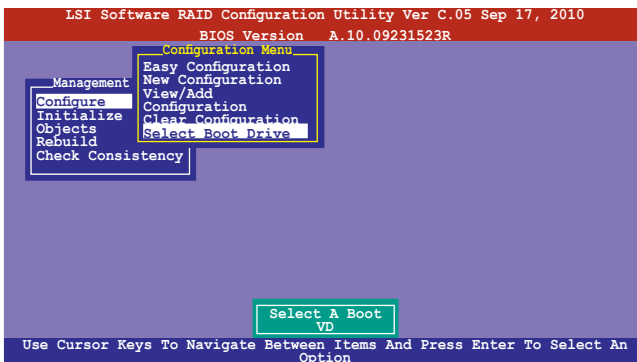

2. When prompted, use the arrow keys to select the bootable virtual drive from the list, then press <Enter>.

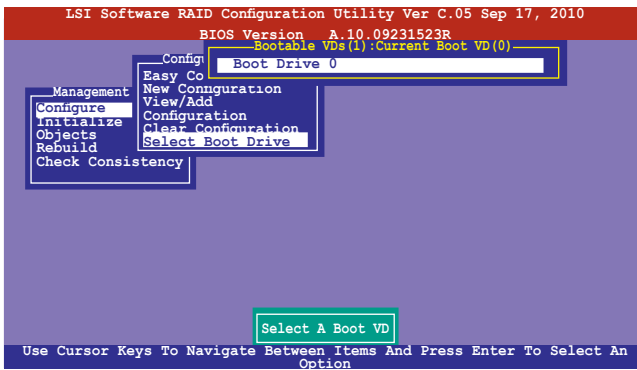

3. The virtual drive is selected as boot drive. Press any key to continue.

6.2.8 Enabling WriteCache

You may manually enable the RAID controller's WriteCache option after creating a RAID set to improve the data transmission performance.



When you enable WriteCache, you may lose data when a power interruption occurs while transmitting or exchanging data among the drives.



The WriteCache function is recommended for RAID 1 and RAID 10 sets.

To enable WriteCache:

1. From the **Management Menu**, select **Objects > Adapter**, select an existing adapter, and then press <Enter> to display the adapter properties.
2. Select **Disk WC**, and then press <Enter> to turn on the option.

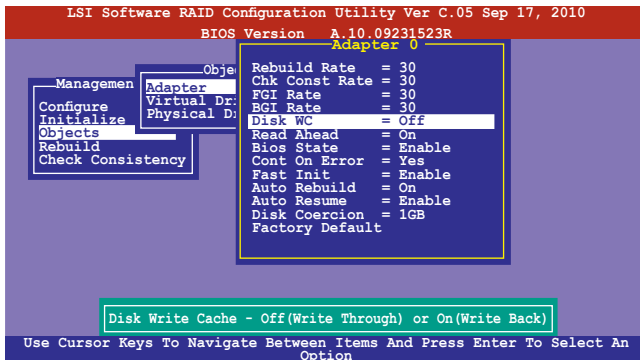

3. From the **Management Menu**, select **Objects > Virtual Drive**, select an existing adapter and press <Enter>. Select **View/Update Parameters** and press <Enter> to display the adapter properties.
4. Select **Disk WC**, and then press <Enter> to turn on the option.

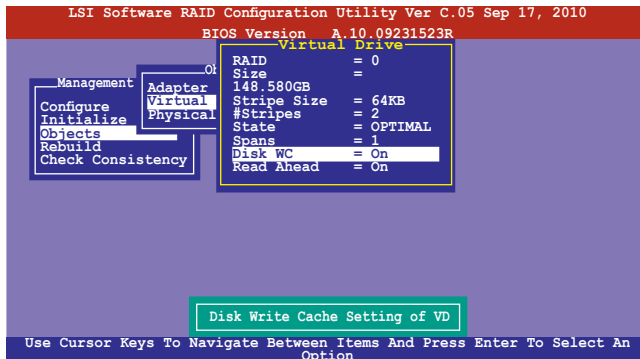

5. When finished, press any key to continue.

6.3 Intel® Rapid Storage Technology enterprise SCU/ SATA Option ROM Utility

The Intel® Rapid Storage Technology enterprise SCU / SATA Option ROM utility allows you to create RAID 0, RAID 1, RAID 10 (RAID 1+0), and RAID 5 set(s) from Serial ATA hard disk drives that are connected to the Serial ATA connectors supported by the Southbridge.

You can create RAID mode by use of onboard AHCI SATA ports.

To use onboard SATA ports:

1. Install all the Serial ATA hard disk drives.
2. Turning on the system. During POST, press,Del. to enter BIOS. Go to **Advanced Menu > PCH SATA Configuration > SATA Mode**, then press <Enter>.
3. Set **SATA Mode** to **RAID Mode** and save, then reboot system.
4. During POST, press <Ctrl+I> to display the utility main menu.

To use SCU SATA ports:

1. Install all the hard disk drives.
2. Turn on the system.
3. Confirm all the SATA hard disk drives you installed are correctly displayed, then reboot system.
4. During POST, press <Ctrl+I> to display the utility main menu.

To enter the Intel® Rapid Storage Technology enterprise SCU option ROM utility:

1. Install all the Serial ATA hard disk drives.
2. Turn on the system.
3. During POST, press <Ctrl+I> to display the utility main menu.

```
Intel(R) Rapid Storage Technology enterprise - SCU Option ROM - 3.0.0.1104
Copyright(C) 2003-11 Intel Corporation. All Rights Reserved.

[ MAIN MENU ]
1. Create RAID Volume          3. Reset Disks to Non-RAID
2. Delete RAID Volume         4. Exit

[ DISK/VOLUME INFORMATION ]

RAID Volumes:
None defined.

Physical Disks:
ID   Drive Model      Serial #              Size Type/Status (Vol ID)
0    ST3300656SS     HWAS0000991753TR    279.3GB Non-RAID Disk
1    ST3300656SS     37VN00009846RAJ1    279.3GB Non-RAID Disk

[↑↓]-Select      [ESC]-Exit      [ENTER]-Select Menu
```

The navigation keys at the bottom of the screen allow you to move through the menus and select the menu options.



The RAID BIOS setup screens shown in this section are for reference only and may not exactly match the items on your screen.



The utility supports maximum four hard disk drives for RAID configuration.

6.3.1 Creating a RAID set

To create a RAID set

1. From the utility main menu, select **1. Create RAID Volume** and press <Enter>. The following screen appears.

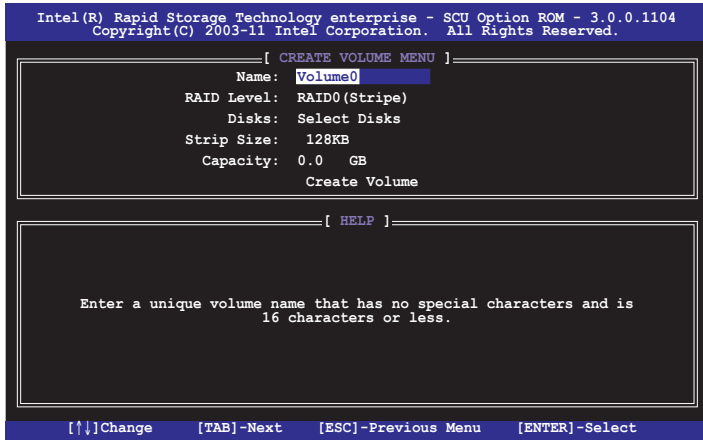

2. Enter a name for the RAID set and press <Enter>.
3. When the **RAID Level** item is selected, press the up/down arrow key to select a RAID level to create, and then press <Enter>.
4. When the **Disks** item is selected, press <Enter> to select the hard disk drives you want to include in the RAID set. The **SELECT DISKS** screen appears.

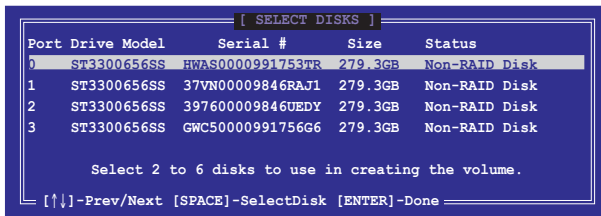

5. Use the up/down arrow key to select a drive, and then press <Space> to select. A small triangle marks the selected drive. Press <Enter> after completing your selection.

- Use the up/down arrow keys to select the stripe size for the RAID array (for RAID 0, 10 and 5 only), and then press <Enter>. The available stripe size values range from 4 KB to 128 KB. The following are typical values:

RAID 0: 128KB

RAID 10: 64KB

RAID 5: 64KB



We recommend a lower stripe size for server systems, and a higher stripe size for multimedia computer systems used mainly for audio and video editing.

- When the **Capacity** item is selected, enter the RAID volume capacity that you want and press <Enter>. The default value indicates the maximum allowed capacity.
- When the **Create Volume** item is selected, press <Enter>. The following warning



- Press <Y> to create the RAID volume and return to the main menu, or <N> to go back to the **CREATE VOLUME** menu.

6.3.2 Creating a Recovery set

To create a recovery set:

- From the utility main menu, select **1. Create RAID Volume** and press <Enter>. The following screen appears.

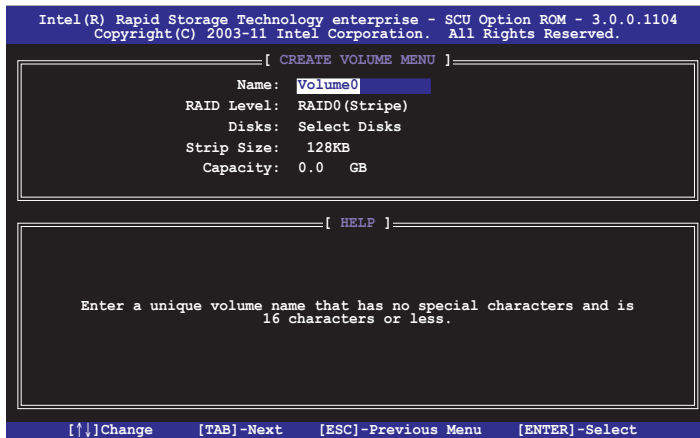

2. Enter a name for the recovery set and press <Enter>.
3. When the **RAID Level** item is selected, press the up/down arrow keys to select **Recovery**, and then press <Enter>.
4. When the **Disks** item is selected, press <Enter> to select the hard disk drives you want to include in the recovery set. The **SELECT DISKS** screen appears.

```

[ SELECT DISKS ]
Port Drive Model Serial # Size Status
0 ST3300656SS HWAS0000991753WR 279.3GB Non-RAID Disk
1 ST3300656SS 37VN00009846RAJ1 279.3GB Non-RAID Disk
2 ST3300656SS 397600009846UEDY 279.3GB Non-RAID Disk
3 ST3300656SS GWC50000991756G6 279.3GB Non-RAID Disk

Select 1 Master and 1 Recovery disk to create volume.

[[↑↓]-Prev/Next [TAB]- (M)aster [SPACE]- (R)ecovery [ENTER]-Done =

```

5. Use the up/down arrow keys to select a drive, press <TAB> to select a Master disk, and then press <SPACE> to select a Recovery disk. A small triangle marks the selected drive. Press <Enter> after completing your selection.
6. When the **Sync** item is selected, use the up/down arrow keys to select a sync option that you want and press <Enter>.
7. When the **Create Volume** item is selected, press <Enter>. The following warning message appears.

```

WARNING: ALL DATA ON SELECTED DISKS WILL BE LOST.
Are you sure you want to create this volume? (Y/N) :

```

8. Press <Y> to create the recovery set and return to the main menu, or <N> to go back to the **CREATE VOLUME** menu.



If a recovery set is created, you cannot add more RAID sets even when you have more non-RAID disks installed in your system.

6.3.3 Deleting a RAID set



Take caution when deleting a RAID set. You will lose all data on the hard disk drives when you delete a RAID set.

To delete a RAID set:

1. From the utility main menu, select **2. Delete RAID Volume** and press <Enter>. The following screen appears.

```
Intel(R) Rapid Storage Technology enterprise - SCU Option ROM - 3.0.0.1104
Copyright(C) 2003-11 Intel Corporation. All Rights Reserved.

[ DELETE VOLUME MENU ]

Name      Level      Drives    Capacity  Status    Bootable
Volume0   RAID0(Stripe)  2         298.0GB   Normal    Yes

[ HELP ]

Deleting a volume will reset the disks to non-RAID.

WARNING: ALL DISK DATA WILL BE DELETED.
(This does not apply to Recovery volumes)

[↑↓]-Select      [ESC]-Previous Menu  [DEL]-Delete Volume
```

2. Use the up/down arrow keys to select the RAID set you want to delete, and then press . The following warning message appears.

```
[ DELETE VOLUME VERIFICATION ]

ALL DATA IN THE VOLUME WILL BE LOST!
(This does not apply to Recovery volumes)

Are you sure you want to delete volume "Volume0"? (Y/N):
```

3. Press <Y> to delete the RAID set and return to the utility main menu, or press <N> to return to the **DELETE VOLUME** menu.

6.3.4 Resetting disks to Non-RAID



Take caution before you reset a RAID volume hard disk drive to non-RAID. Resetting a RAID volume hard disk drive deletes all internal RAID structure on the drive.

To reset a RAID set hard disk drive:

1. From the utility main menu, select **3. Reset Disks to Non-RAID** and press <Enter>. The following screen appears.

```
[ RESET RAID DATA ]
Resetting RAID disk will remove its RAID structures
and revert it to a non-RAID disk.

WARNING: Resetting a disk causes all data on the disk to be lost.
(This does not apply to Recovery volumes)

-----
Post Drive Model      Serial #             Size   Status
-----
1  ST3300656SS  37VN0009846RAJ1  279.3GB  Member Disk

[↑↓]-Previous/Next  [SPACE]-Selects [ENTER]-Selection
                    Complete
```

2. Use the up/down arrow keys to select the RAID set drive(s) you want to reset, and then press <Space> to select.
3. Press <Enter> to reset the RAID set drive(s). A confirmation message appears.
4. Press <Y> to reset the drive(s) or press <N> to return to the utility main menu.

6.3.5 Exiting the Intel® Rapid Storage Technology utility

To exit the utility:

1. From the utility main menu, select **4. Exit**, and then press <Enter>. The following warning message appears.

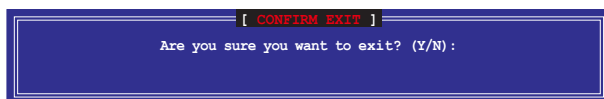

2. Press <Y> to exit or press <N> to return to the utility main menu.

6.3.6 Rebuilding the RAID



This option is only for the RAID 1 set.

Rebuilding the RAID with other non-RAID disk

If any of the SATA hard disk drives included in the RAID 1 array failed, the system displays the status of the RAID volume as “**Degraded**” during POST. You can rebuild the RAID array with other installed non-RAID disks.

To rebuild the RAID with other non-RAID disk:

1. At the prompt, press <Ctrl> + <I> to enter the Intel Rapid Storage Technology option ROM utility.
2. If there is a non-RAID SATA Hard Disk available, the utility will prompt to rebuild the RAID. Press <Enter>, and then use up/down arrow keys to select the destination disk or press <ESC> to exit.

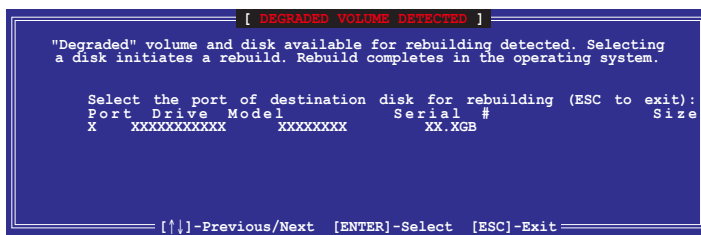

Select a destination disk with the same size as the original hard disk.

- The utility immediately starts rebuilding after the disk is selected. The status of the degraded RAID volume is changed to **“Rebuild”**.

```

Intel(R) Rapid Storage Technology enterprise - SCU Option ROM - 3.0.0.1104
Copyright(C) 2003-11 Intel Corporation. All Rights Reserved.

----- [ MAIN MENU ] -----
1. Create RAID Volume          3. Reset Disks to Non-RAID
2. Delete RAID Volume         4. Exit

----- [ DISK/VOLUME INFORMATION ] -----

RAID Volumes:
ID   Name      Level      Strip   Size   Status   Bootable
0    Volume0   RAID1(Mirror)  N/A    149.0GB Rebuild  Yes
* = Data is Encrypted

Physical Devices:
Port Drive Model      Serial #          Size   Type/Status (Vol ID)
1    ST3160812AS        9LS0F4HL         149.0GB Member Disk (0)
2    ST3160812AS        3LS0JYL8         149.0GB Member Disk (0)

Volumes with "Rebuild" status will be rebuilt within the operating system.

[↑↓]-Select      [ESC]-Exit      [ENTER]-Select Menu

```

- Exit Intel Rapid Storage Technology and reboot the system.
- Under Microsoft® Windows OS, select **Start > Programs > Intel Rapid Storage > Intel Rapid Storage Console** or click the **Intel Rapid Storage Technology** tray icon to load the Intel Rapid Storage Manager utility.
- From the **View** menu, select **Advanced Mode** to display the details of the Intel Rapid Storage Console.
- From the **Volumes view** option, select **RAID volume** to view the rebuilding status. When finished, the status is changed to **“Normal”**.

Rebuilding the RAID with a new hard disk

If any of the SATA hard disk drives included in the RAID array failed, the system displays the status of the RAID volume as **“Degraded”** during POST. You may replace the disk drive and rebuild the RAID array.

To rebuild the RAID with a new hard disk:

- Remove the failed SATA hard disk and install a new SATA hard disk of the same specification into the same SATA Port.



Select a destination disk with the same size as the original hard disk.

- Reboot the system and then follow the steps in section **Rebuilding the RAID with other non-RAID disk**.

6.3.7 Setting the Boot array in the BIOS Setup Utility

You can set the boot priority sequence in the BIOS for your RAID arrays when creating multi-RAID using the Intel® Rapid Storage Technology.

To set the boot array in the BIOS:



Set at least one of the arrays bootable to boot from the hard disk.

1. Reboot the system and press to enter the BIOS setup utility during POST.
2. Go to the **Boot** menu and select the boot option priority.
3. Use up/down arrow keys to select the boot priority and press <Enter>. See section **4.7 Boot menu** for details.
4. From the **Exit** menu, select **Save Changes & Exit**, then press <Enter>.
5. When the confirmation window appears, select **Yes**, then press <Enter>.

6.4 Intel® Rapid Storage Technology enterprise Utility (Windows)

The Intel® Rapid Storage Technology enterprise utility allows you to create RAID 0, RAID 1, RAID 10 (RAID 1+0), and RAID 5 set(s) from Serial ATA hard disk drives that are connected to the Serial ATA connectors supported by the Southbridge.

To enter the Intel® Rapid Storage Technology enterprise SCU option ROM utility under Windows operating system:

1. Turn on the system to windows desktop.
2. Click the Intel® Rapid Storage Technology enterprise icon to display the main menu.

Your storage system is configured for data protection, increased performance and optimal data storage capacity. You can also create additional volumes to further optimize your storage system.

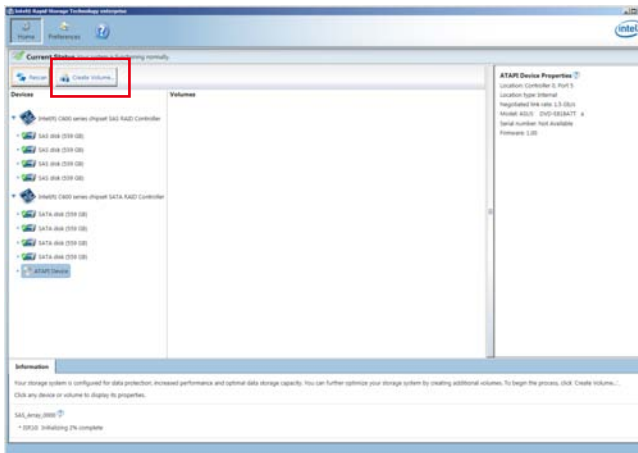

You can click Rescan to re-scan any attached hard disks.

6.4.1 Creating a RAID set

To create a RAID set:

1. From the utility main menu, select **Create Volume** and select the volume type.
2. Click **Next**.

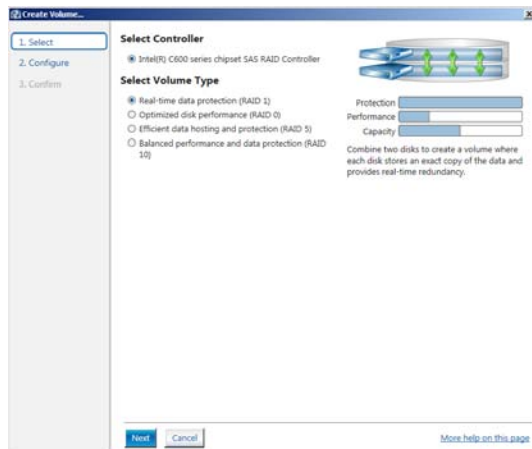

3. Enter a name for the RAID set, then select the array disks.
4. Select the **Volume Size** tab.
5. Click **Next**.





- If your hard disk contains data and you do not want to keep this data, click **NO** in the next column if it is displayed.
- You can enable the volume write-cache or volume initialization function from the Advanced tab.

6. Confirm the volume creation, then click **Create Volume** to continue.



This process could take a while depending on the number and size of the disks. You can continue using other applications during this time.

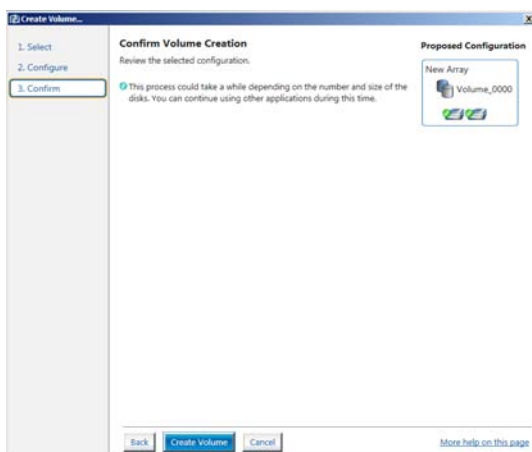

Click **OK** when finished.

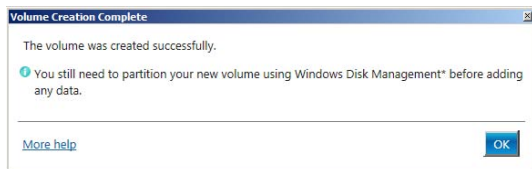

You still need to partition your new volume using Windows Disk Management before adding any data.

When you are finished, you will see the following screen in Volumes field and you can change related items in the Volume Properties field.

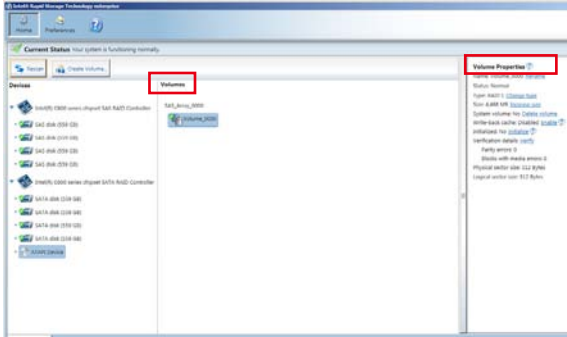

6.4.2 Change Volume Type

When you have created the RAID set, you can view or change its related items in the Volume Properties field.

To change the type in Volume Properties:

1. Click the SAS array items you want to change in Volumes field.
2. From the Volume Properties field, select **Type:RAID 1 Change type**.

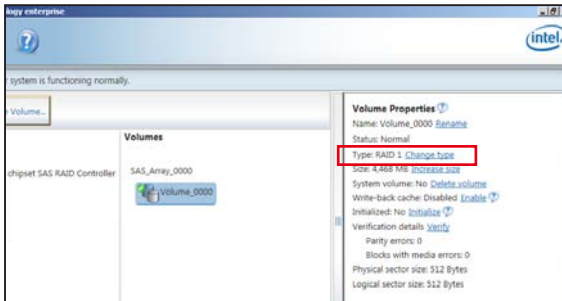

3. You can change the name, select the new volume type, and select additional disks to include in the new volume if needed.
4. Select the Data stripe size for the RAID array (for RAID 0, 10 and 5 only), and click **OK**. The available stripe size values range from 4 KB to 128 KB. The following are typical values:
 - RAID 0: 128KB
 - RAID 10: 64KB
 - RAID 5: 64KB

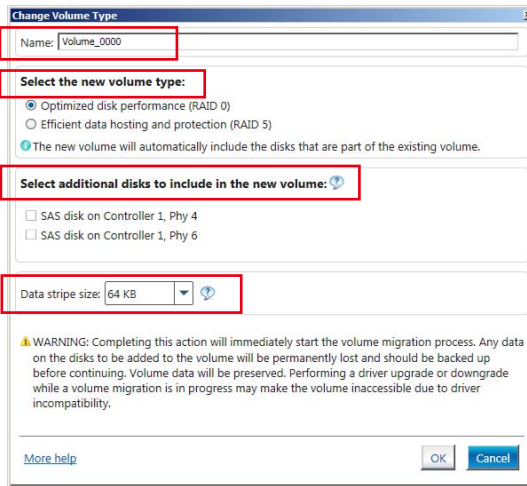

We recommend a lower stripe size for server systems, and a higher stripe size for multimedia computer systems used mainly for audio and video editing.

6.4.3 Delete volume



Be cautious when deleting a volume. You will lose all data on the hard disk drives. Back up data before continuing.

To delete a volume:

1. From the utility main menu, select the volume (exp. Volume_0000) in Volumes field you want to delete.

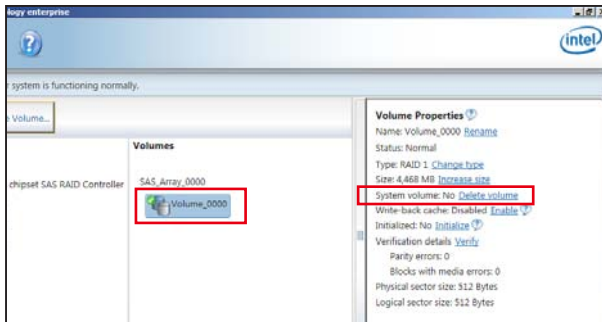

2. Select **Delete volume** in the Volume Properties field. The following screen appears.

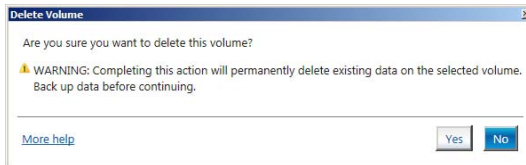

3. Click **Yes** to delete the volume and return to the utility main menu, or click **No** to return to the main menu.

6.4.4 Preferences

System Preferences

Allow you set to show the notification area icon and show system information, warning, or errors.

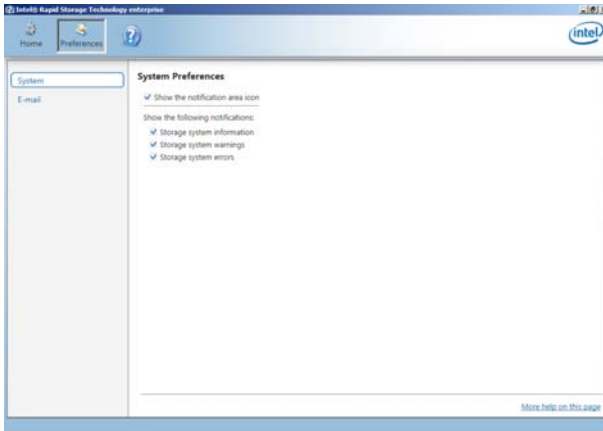

E-Mail Preferences

Allow you set to sent e-mail of the following events:

- Storage system information
- Storage system warnings
- Storage system errors

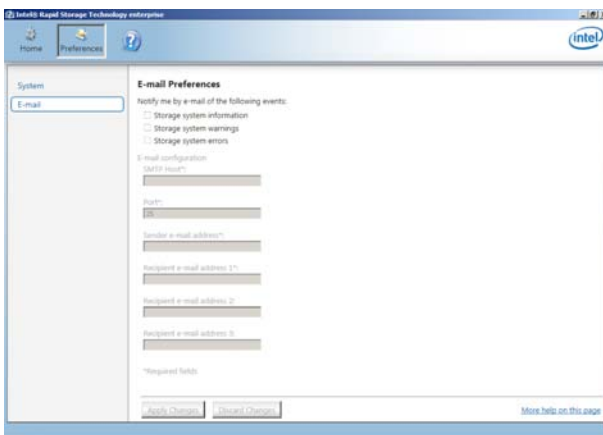

Driver installation

7

7.1 RAID driver installation

After creating the RAID sets for your server system, you are now ready to install an operating system to the independent hard disk drive or bootable array. This part provides the instructions on how to install the RAID controller drivers during OS installation.

7.1.1 Creating a RAID driver disk



The system does not include a floppy drive. You have to use a USB floppy drive when creating a SATA RAID driver disk.



If you have created RAID sets with the LSI Software RAID configuration utility, the boot priority of the SATA optical disk drive has to be manually adjusted. Otherwise, the system will not boot from the connected SATA ODD.

A floppy disk with the RAID driver is required when installing Windows® XP / Server 2003 or Linux operating system on a hard disk drive that is included in a RAID set. You can create a RAID driver disk in DOS (using the Makedisk application in the support DVD).

To create a RAID driver disk in DOS environment:

1. Place the motherboard support DVD in the optical drive.
2. Restart the computer, and then enter the BIOS Setup.
3. Select the optical drive as the first boot priority to boot from the support DVD. Save your changes, and then exit the BIOS Setup.
4. Restart the computer. The Makedisk menu appears.

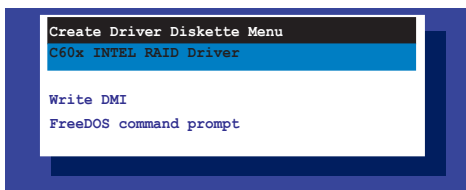

5. Use the arrow keys to select the type of RAID driver disk you want to create and press <Enter> to enter the sub-menu.

C60x INTEL RAID Driver

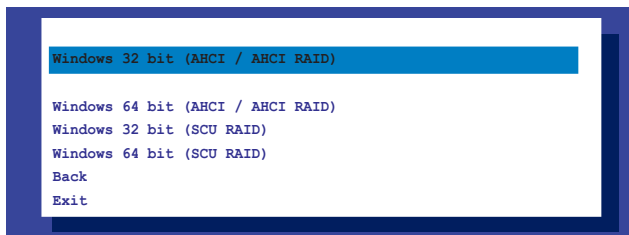

LSI 2008 SAS2 Driver

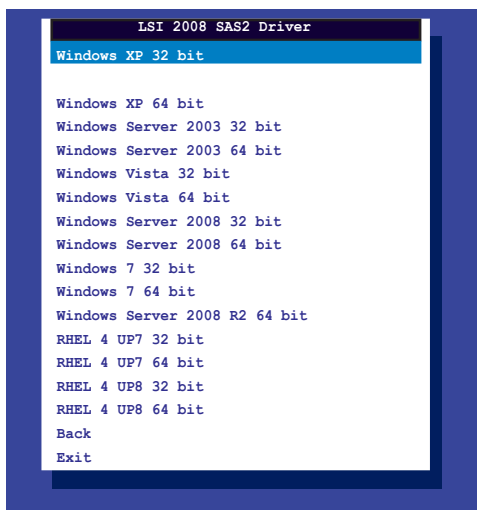

6. Locate the RAID driver and place a blank, high-density floppy disk to the floppy disk drive.
7. Press <Enter>.
8. Follow the screen instructions to create the driver disk.

To create a RAID driver disk in Windows® environment:

1. Start Windows®.
2. Place the motherboard support DVD into the optical drive.
3. Go to the **Make disk** menu, and then select the type of RAID driver disk you want to create.
4. Insert a floppy disk into the USB floppy disk drive.
5. Follow the succeeding screen instructions to complete the process.



Write-protect the floppy disk to avoid computer virus infection.

To create a RAID driver disk in Red Hat® Enterprise Linux server environment:

1. Insert a blank formatted high-density floppy disk to the USB floppy disk drive.
2. Type `dd if=XXX.img of=/dev/fd0` to decompress the file into the floppy disk from the following path in the support DVD:

For LSI MegaRAID Driver

`\\Drivers\C60x LSI RAID\Driver\makedisk\Linux`

3. Eject the floppy disk.

7.1.2 Installing the RAID controller driver

Windows® Server 2008 OS installation

To install the RAID controller driver when installing Windows® Server 2008 OS:

1. Boot the computer using the Windows® Server 2008 OS installation disc. Follow the screen instructions to start installing Windows Server 2008.
2. When prompted to choose a type of installation, click **Custom (advanced)**.

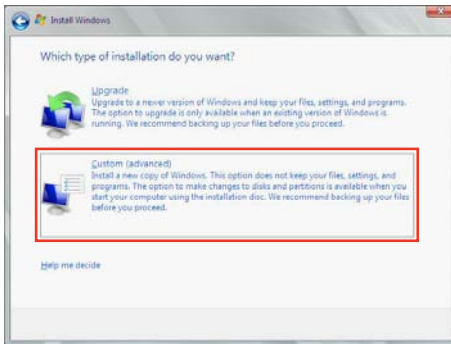

3. Click **Load Driver**.

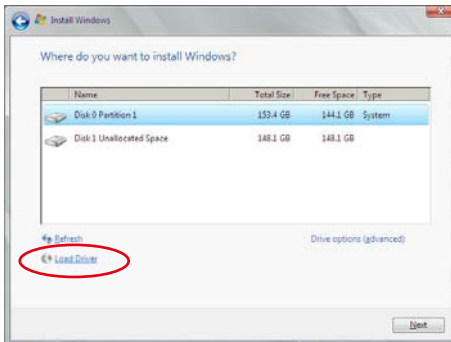

- A message appears, reminding you to insert the installation media containing the driver of the RAID controller driver. If you have only one optical drive installed in your system, eject the Windows OS installation disc and replace with the motherboard Support DVD into the optical drive. Click **Browse** to continue.

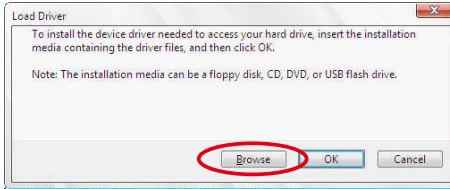

- Locate the driver in the corresponding folder of the Support DVD, and then click **OK** to continue.
- Select the RAID controller driver you need from the list and click **Next**.
- When the system finishes loading the RAID driver, replace the motherboard Support DVD with the Windows Server installation disc. Select the drive to install Windows and click **Next**.

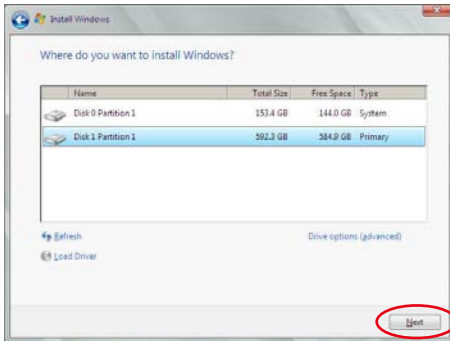

- Follow the screen instructions to continue.

Red Hat® Enterprise Linux OS 5.6

To install the LSI MegaRAID controller driver when installing Red Hat® Enterprise OS:

1. Boot the system from the Red Hat® OS installation CD.
2. At the **boot:**, type **linux dd noprobe=ata1 noprobe=ata2...**, then press <Enter>.



The number of ATA varies with the hard disk drive number you have when building a RAID set. For example, if you want to build a RAID set with 6 hard disk drives, type command line: **linux dd noprobe=ata1 noprobe=ata2 noprobe=ata3 noprobe=ata4 noprobe=ata5 noprobe=ata6**.

```
- To install or upgrade in graphical mode, press the <ENTER> key.
- To install or upgrade in text mode, type: linux text <ENTER>.
- Use the function keys listed below for more information.
[F1-Main] [F2-Options] [F3-General] [F4-Kernel] [F5-Rescue]
boot: linux dd noprobe=ata1 noprobe=ata2
```

3. Select **Yes** using the <Tab> key when asked if you have the driver disk, then press <Enter>.

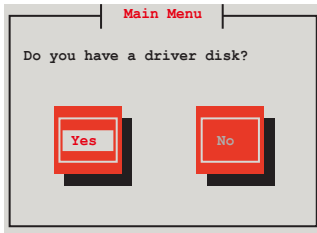

4. Insert the Red Hat® Enterprise RAID driver disk to the USB floppy disk drive, select **OK**, then press <Enter>.

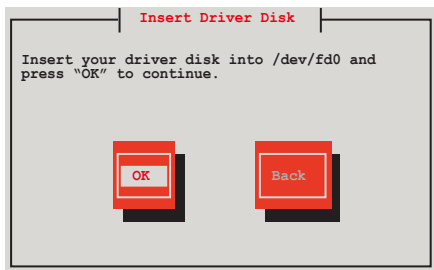

The drivers for the RAID card are installed to the system.

5. When asked if you will load additional RAID controller drivers, select **No**, then press <Enter>.

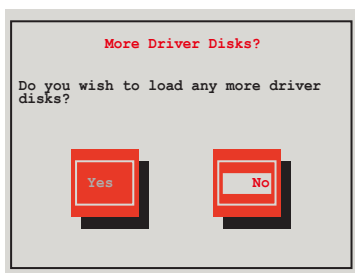

6. Follow the onscreen instructions to finish the OS installation.
7. When the installation is completed, DO NOT click Reboot. Press <Ctrl> + <Alt> + <F2> to switch to the command-line interface from graphic user interface.
8. Type the following commands when using a legacy floppy disk.

```
mkdir /mnt/driver
mount /dev/fd0 /mnt/driver
cd /mnt/driver
sh replace_ahci.sh
reboot
```

Red Hat® Enterprise Linux OS 6.1

To install the LSI MegaRAID controller driver when installing Red Hat® Enterprise OS:

1. Boot the system from the Red Hat® OS installation CD.
2. Press <Tab> to edit options.

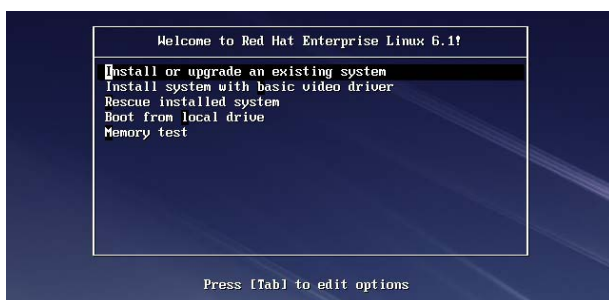

3. While booting from DVD, press <ESC> to give the third party driver. Enter the following command at the boot: **Linux dd blacklist=iscsi blacklist=ahci nodmraid**, then press <ENTER>.

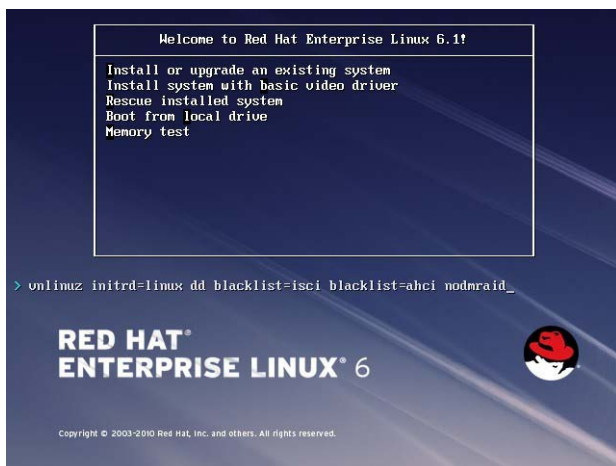

4. Select **Yes** using the <Tab> key when asked if you have the driver disk, then press <Enter>.

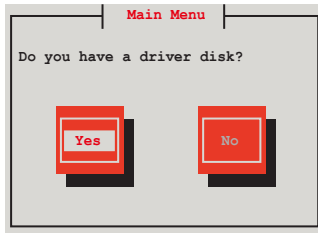

5. Select the device that will serve as the source for the driver disk. Choose one you like to use and select **OK**, then press <Enter>.

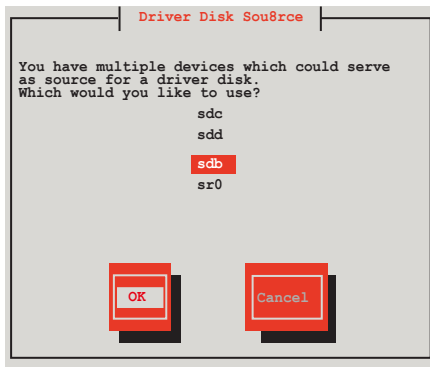

6. Insert the Red Hat® Enterprise RAID driver disk to the USB floppy disk drive, select **OK**, then press <Enter>.

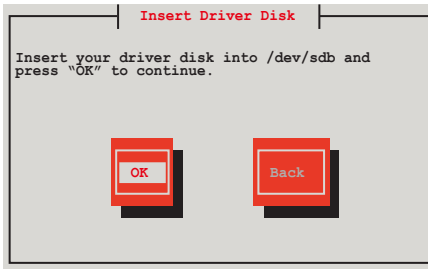

The drivers for the RAID card are installed to the system.

7. When asked if you will load additional RAID controller drivers, select **No**, then press <Enter>.

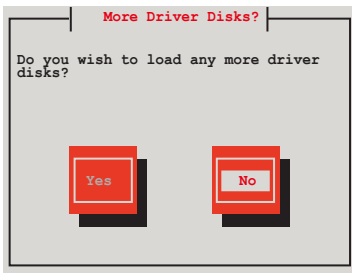

8. Follow the onscreen instructions to finish the OS installation.

Preparing the Linux Driver

Ensure that there is another computer with a Linux-based OS to create the RAID driver. When creating the RAID driver, you may refer to the examples below which uses a 64bit SUSE Linux system to create a 64bit RAID driver for SUSE11 sp1.

1. Copy the image file into the Linux system.

Example: **megasr-15.00.0120.2012-1-sles11-ga-x86_64.img**

2. Create a folder.

Example: **image**

3. Mount the image file into the image folder using this command format:

mount -o loop [image file name] image

Example: **mount -o loop megasr-15-15.00.0120.2012-1-sles11-ga-x86_64.img image**



```
asus@linux-doe5:/tmp
File Edit View Terminal Tabs Help
asus@linux-doe5:/tmp> su -
Password:
linux-doe5:~ # ..
linux-doe5:/ # cd tmp
linux-doe5:/tmp # mount -o loop megasr-15.00.0120.2012-1-sles11-ga-x86_64.img image
linux-doe5:/tmp #
```

4. Copy the contents of the image directory, labeled as **01**, into a FAT32 USB drive.



5. Rename the **01** folder to **CD Image**.

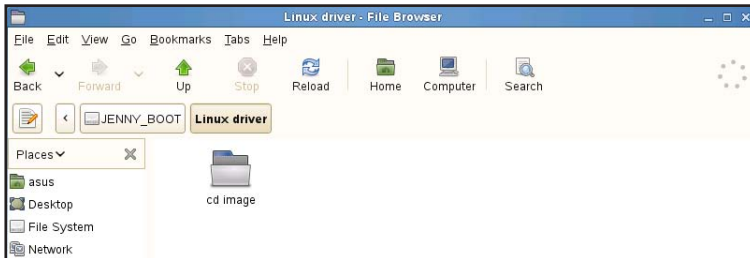

Installing SUSE 11 Linux OS

To install the LSI MegaRAID controller driver when installing SUSE Linux Enterprise Server OS:

1. Boot the system from the SUSE OS installation CD.
2. Use the arrow keys to select **Installation** from the **Boot Options** menu.



3. Press <F6>, then select **Yes** from the menu. Press <Enter>.



4. Use the USB drive to provide the third-party driver during the OS installation. Type the command **brokenmodules=ahci** in Boot Options field, and press <Enter>.



5. When the screen below appears, select the USB floppy disk drive (sda) as the driver update medium. Select **OK**, then press <Enter>.

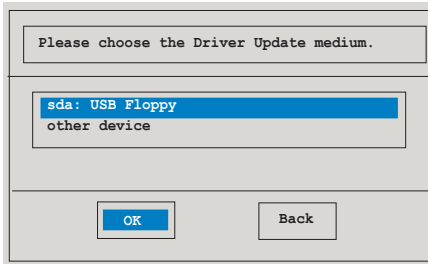

6. Select **Back** and follow the onscreen instructions to finish the installation.

7.2 Intel® chipset device software installation

This section provides the instructions on how to install the Intel® chipset device software on the system.

You need to manually install the Intel® chipset device software on a Windows operating system.

To install the Intel® chipset device software:

1. Restart the computer, and then log on with Administrator privileges.
2. Insert the motherboard/system support DVD to the optical drive. The support DVD automatically displays the Drivers menu if Autorun is enabled in your computer.



If Autorun is NOT enabled in your computer, browse the contents of the support DVD to locate the file **ASSETUP.EXE** from the BIN folder. Double-click the **ASSETUP.EXE** to run the support DVD.

3. Click the item **Intel Chipset Device Software** from the menu.



- The **Intel® Chipset Device Software** window appears. Click **Next** to start installation.



- Select **Yes** to accept the terms of the License Agreement and continue the process.



6. Read the **Readme File Information** and click **Next** to continue the installation.

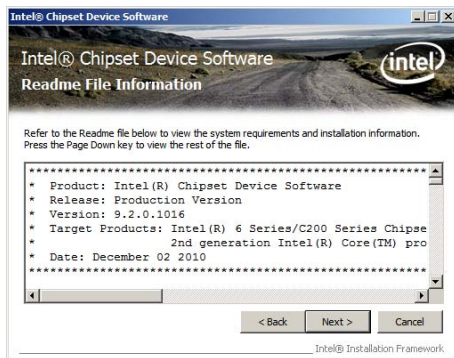

7. Toggle **Yes, I want to restart the computer now** and click **Finish** to complete the setup process.



7.3 Intel® Network Connections Software installation

This section provides the instructions on how to install the Intel® Network Connections Software on the system.

You need to manually install the Intel® Network Connections Software on a Windows® operating system. To install the Intel® Network Connections Software:

1. Restart the computer, and then log on with Administrator privileges.
2. Insert the motherboard/system support DVD to the optical drive. The support DVD automatically displays the Drivers menu if Autorun is enabled in your computer.



Windows® automatically detects the LAN controllers and displays a New Hardware Found window. Click **Cancel** to close this window.

If Autorun is NOT enabled in your computer, browse the contents of the support DVD to locate the file **ASSETUP.EXE** from the BIN folder. Double-click the **ASSETUP.EXE** to run the DVD.

3. Click the **Intel® Network Connections Software**.

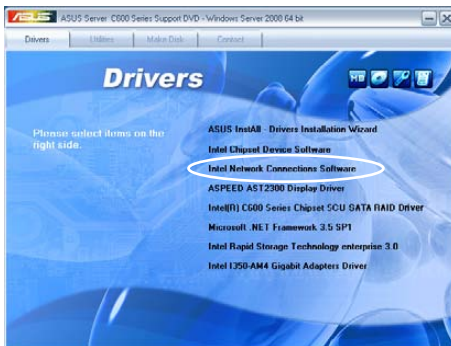

4. Click **Install Drivers and Software**.

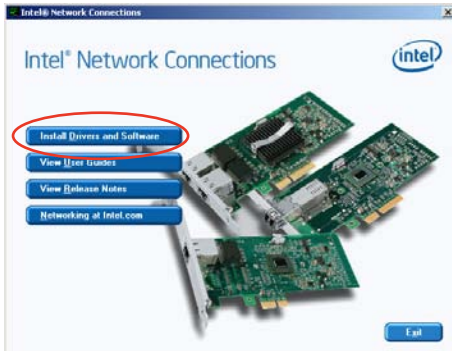

5. Click **Next** when the Intel® Network Connections–InstallShield Wizard window appears.



6. Toggle **I accept the terms in the license agreement** and click **Next** to continue.

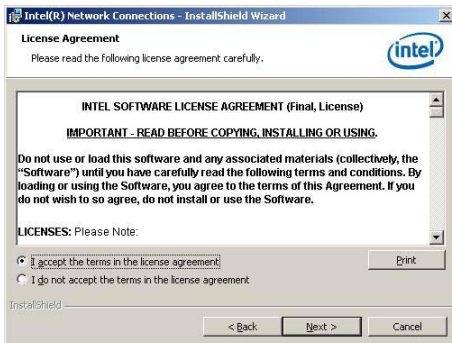

7. Follow the screen instructions to complete the installation.

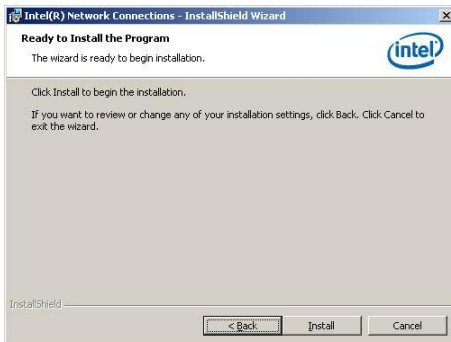

8. When finished, click **Finish** to continue.



7.4 VGA driver installation

This section provides the instructions on how to install the ASPEED Video Graphics Adapter (VGA) driver.

You need to manually install the ASPEED VGA driver on a Windows® operating system.

To install the ASPEED VGA driver:

1. Restart the computer, and then log on with Administrator privileges.
2. Insert the motherboard/system support DVD to the optical drive. The support DVD automatically displays the Drivers menu if Autorun is enabled in your computer.



If Autorun is NOT enabled in your computer, browse the contents of the support DVD to locate the file **ASSETUP.EXE** from the BIN folder. Double-click the **ASSETUP.EXE** to run the support DVD.

3. Click the **ASPEED AST2300 Display Driver**.

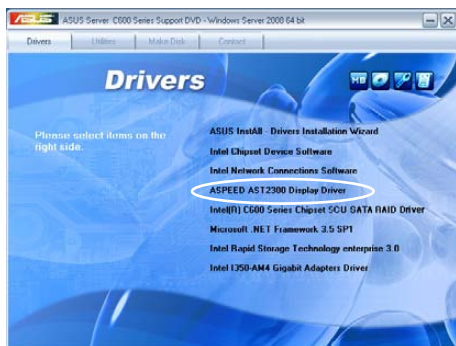

4. When the ASPEED Graphics installation wizard appears, click **Next** to start the installation.

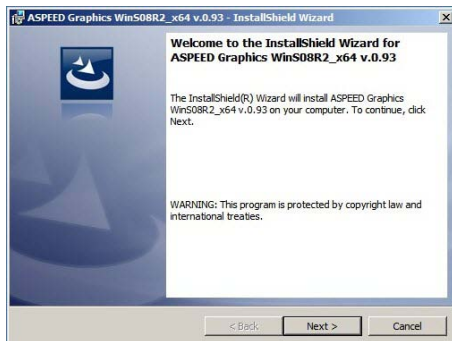

5. Toggle **I accept the terms in the license agreement** and click **Next** to continue.

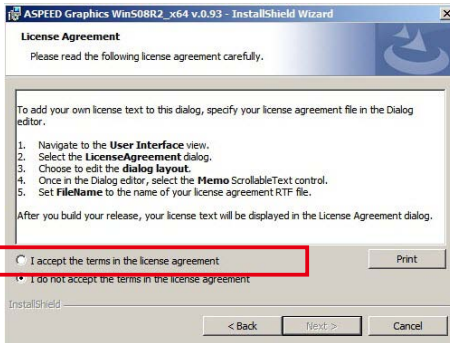

6. Enter the user information and click **Next** to continue.

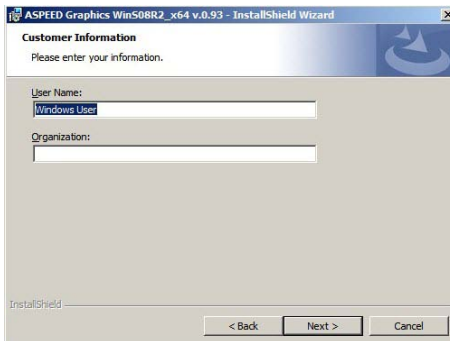

7. Select a setup type and click **Next** to continue.

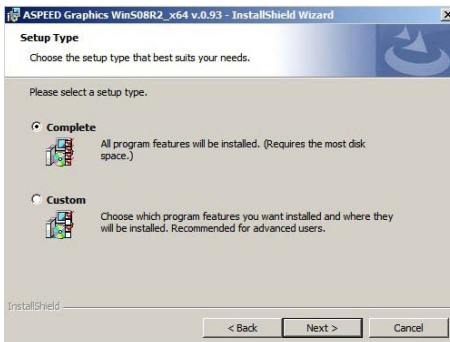

8. Click **Install**.

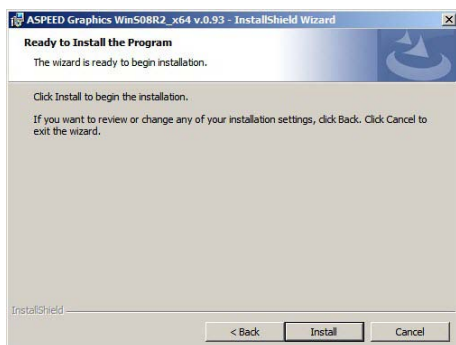

9. When the installation completes, click **Finish** to restart your computer before using the program.

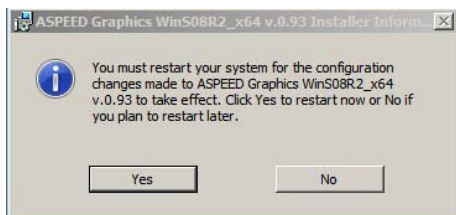
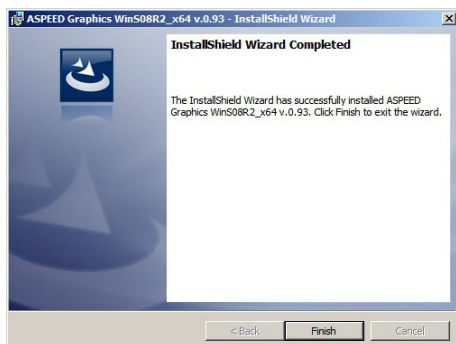

7.5 Intel® C600 Series Chipset SCU SATA RAID Driver

This section provides the instructions on how to install the Intel® C600 Series Chipset Driver on the system.

You need to manually install the Intel® C600 Series Chipset SCU SATA RAID Driver on a Windows operating system.

To install the drivers:

1. Restart the computer, and then log on with Administrator privileges.
2. Insert the motherboard/system support DVD to the optical drive. The support DVD automatically displays the Drivers menu if Autorun is enabled in your computer.



If Autorun is NOT enabled in your computer, browse the contents of the support DVD to locate the file **ASSETUP.EXE** from the BIN folder. Double-click the **ASSETUP.EXE** to run the support DVD.

3. Click the item **Intel® C600 Series Chipset SCU SATA RAID Driver** from the menu, and then follow the onscreen instructions to complete the installation.

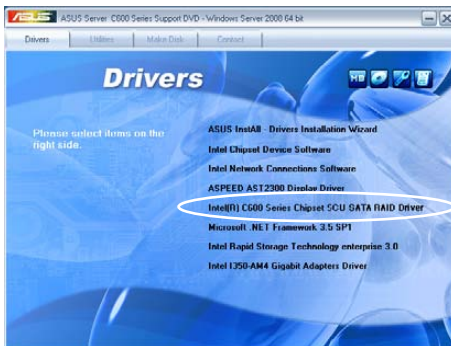

7.6 Microsoft .NET Framework 3.5 SP1

This section provides the instructions on how to install the Microsoft .NET Framework 3.5 SP1 software on the system.

You need to manually install the Intel® Microsoft .NET Framework 3.5 SP1 software on a Windows operating system.

To install the drivers:

1. Restart the computer, and then log on with Administrator privileges.
2. Insert the motherboard/system support DVD to the optical drive. The support DVD automatically displays the Drivers menu if Autorun is enabled in your computer.



If Autorun is NOT enabled in your computer, browse the contents of the support DVD to locate the file ASSETUP.EXE from the BIN folder. Double-click the ASSETUP.EXE to run the support DVD.

3. Click the item **Microsoft .NET Framework 3.5 SP1** software from the menu, and then follow the onscreen instructions to complete the installation.

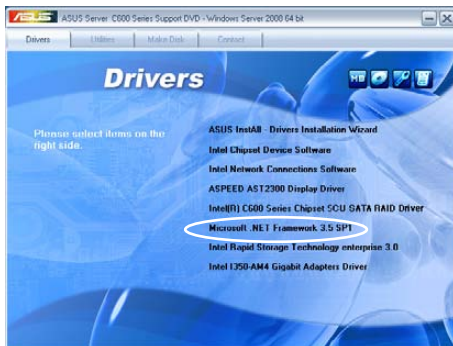

7.7 Intel® Rapid Storage Technology enterprise 3.0 installation

This section provides the instructions on how to install the Intel® Rapid Storage Technology enterprise 3.0 on the system.

You need to manually install the Intel® Rapid Storage Technology enterprise 3.0 utility on a Windows® operating system.

To install the Intel® Rapid Storage Technology enterprise 3.0 utility:

1. Restart the computer, and then log on with Administrator privileges.
2. Insert the motherboard/system support DVD to the optical drive. The support DVD automatically displays the Drivers menu if Autorun is enabled in your computer.



If Autorun is NOT enabled in your computer, browse the contents of the support DVD to locate the file **ASSETUP.EXE** from the BIN folder. Double-click the **ASSETUP.EXE** to run the support DVD.

3. Click the **Intel® Rapid Storage Technology enterprise 3.0**.



4. When the Welcome to the Setup Program appears, click **Next**.



5. Read the Warning message and click **Next** to continue.



6. Read the License Agreement and click **Yes** to continue.



7. Read the **Readme File Information** and click **Next** to continue.

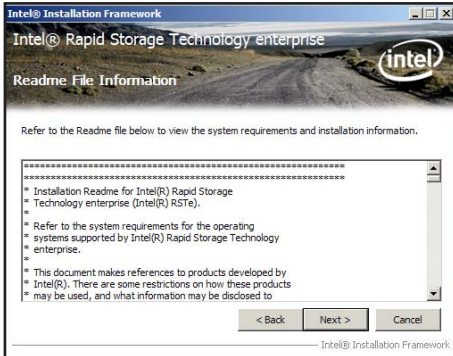

8. After completing the installation, click **Next** to complete the setup process.

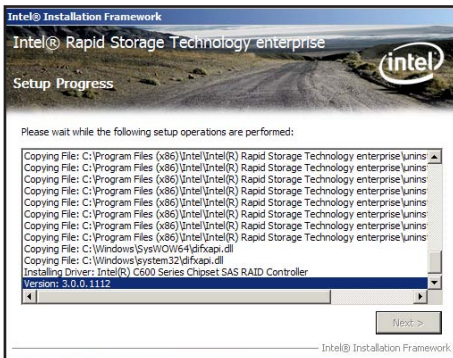

9. Select **Yes, I want to restart my computer now** and click **Finish** to restart your computer before using the program.



7.8 Intel® I350 Gigabit Adapters Driver installation

This section provides the instructions on how to install Intel® I350 Gigabit Adapters Driver.

To install the Intel® I350 Gigabit Adapters Driver on a Windows® OS:

1. Restart the computer, and then log on with Administrator privileges.
2. Insert the motherboard/system support DVD to the optical drive. The DVD automatically displays the Drivers menu if Autorun is enabled in your computer.



If Autorun is NOT enabled in your computer, browse the contents of the support DVD to locate the file **AUTORUN.EXE** and double-click the **AUTORUN.EXE** and follow step 4 to run the installation.

3. Click **Intel® I350-AM4 Gigabit Adapters Driver**.

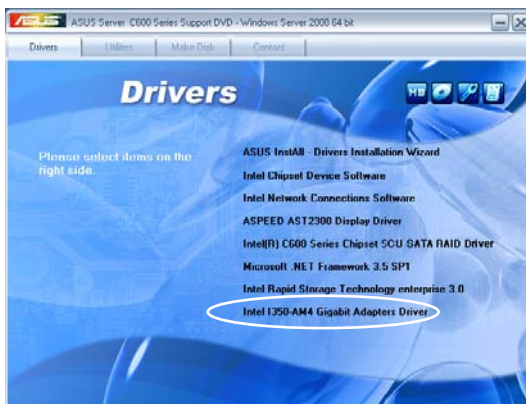

4. When the **Intel® PRO Network Connections – InstallShield Wizard** window appears, click **Next**.



5. Click **I accept the terms in the license agreement** and then click **Next** to continue.



6. Select the programs you want to install and click **Next** to continue.

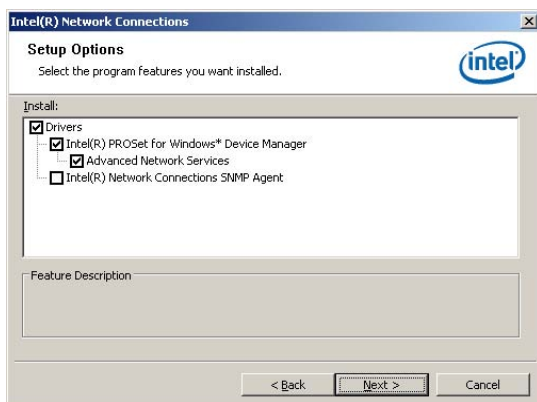

7. Click **Install**.

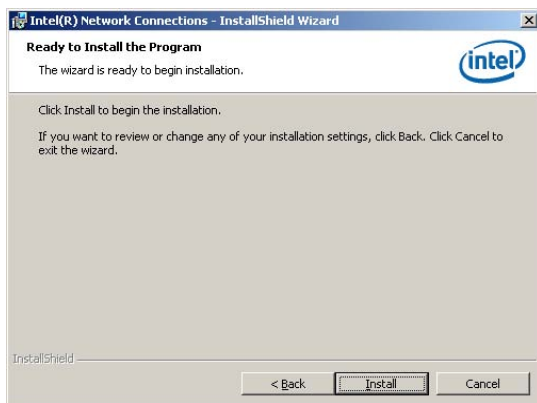

8. Wait for the installation process to complete..

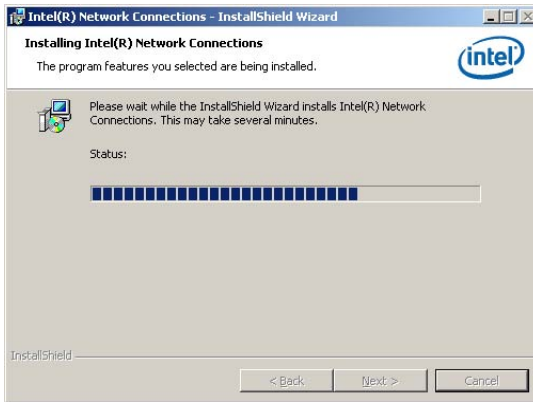

9. Click **Finish** to finish the installation.

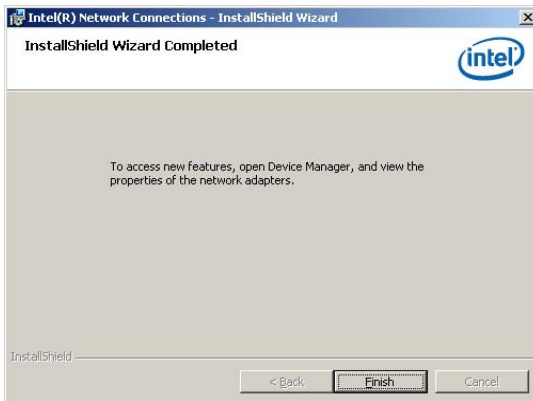

7.9 Management applications and utilities installation

The support DVD that came with the motherboard package contains the drivers, management applications, and utilities that you can install to avail all motherboard features.



The contents of the support DVD are subject to change at any time without notice. Visit the ASUS website at www.asus.com for updates.

7.9.1 Running the support DVD

Place the support DVD to the optical drive. The DVD automatically displays the Drivers menu if Autorun is enabled in your computer.



If Autorun is NOT enabled in your computer, browse the contents of the support DVD to locate the file **ASSETUP.EXE** from the BIN folder. Double-click the **ASSETUP.EXE** to run the support DVD.

7.9.2 Drivers menu

The Drivers menu shows the available device drivers if the system detects installed devices. Install the necessary drivers to activate the devices.



The screen display and driver options vary under different operating system versions.



7.9.3 Utilities menu

The Utilities menu displays the software applications and utilities that the motherboard supports. Click an item to install.



7.9.4 Make disk menu

The Make disk menu contains items to create the Intel RAID driver disks.



7.9.5 Contact information

Click the Contact tab to display the ASUS contact information. You can also find this information on the inside front cover of this user guide.

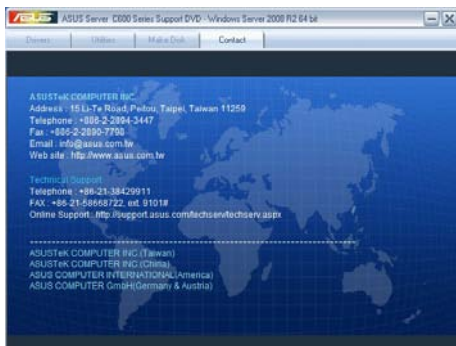

Appendices

Notices

Federal Communications Commission Statement

This device complies with Part 15 of the FCC Rules. Operation is subject to the following two conditions:

- This device may not cause harmful interference.
- This device must accept any interference received including interference that may cause undesired operation.

This equipment has been tested and found to comply with the limits for a Class B digital device, pursuant to Part 15 of the FCC Rules. These limits are designed to provide reasonable protection against harmful interference in a residential installation. This equipment generates, uses and can radiate radio frequency energy and, if not installed and used in accordance with manufacturer's instructions, may cause harmful interference to radio communications. However, there is no guarantee that interference will not occur in a particular installation. If this equipment does cause harmful interference to radio or television reception, which can be determined by turning the equipment off and on, the user is encouraged to try to correct the interference by one or more of the following measures:

- Reorient or relocate the receiving antenna.
- Increase the separation between the equipment and receiver.
- Connect the equipment to an outlet on a circuit different from that to which the receiver is connected.
- Consult the dealer or an experienced radio/TV technician for help.



The use of shielded cables for connection of the monitor to the graphics card is required to assure compliance with FCC regulations. Changes or modifications to this unit not expressly approved by the party responsible for compliance could void the user's authority to operate this equipment.

Canadian Department of Communications Statement

This digital apparatus does not exceed the Class B limits for radio noise emissions from digital apparatus set out in the Radio Interference Regulations of the Canadian Department of Communications.

This class B digital apparatus complies with Canadian ICES-003.

REACH

Complying with the REACH (Registration, Evaluation, Authorisation, and Restriction of Chemicals) regulatory framework, we published the chemical substances in our products at ASUS REACH website at <http://csr.asus.com/english/REACH.htm>.



DO NOT throw the motherboard in municipal waste. This product has been designed to enable proper reuse of parts and recycling. This symbol of the crossed out wheeled bin indicates that the product (electrical and electronic equipment) should not be placed in municipal waste. Check local regulations for disposal of electronic products.



DO NOT throw the mercury-containing button cell battery in municipal waste. This symbol of the crossed out wheeled bin indicates that the battery should not be placed in municipal waste.

ASUS Recycling/Takeback Services

ASUS recycling and takeback programs come from our commitment to the highest standards for protecting our environment. We believe in providing solutions for you to be able to responsibly recycle our products, batteries, other components as well as the packaging materials. Please go to <http://csr.asus.com/english/Takeback.htm> for detailed recycling information in different regions.

ASUS contact information

ASUSTeK COMPUTER INC.

Address	15 Li-Te Road, Peitou, Taipei, Taiwan 11259
Telephone	+886-2-2894-3447
Fax	+886-2-2890-7798
E-mail	info@asus.com.tw
Web site	www.asus.com.tw

Technical Support

Telephone	+86-21-38429911
Online support	support.asus.com

ASUS COMPUTER INTERNATIONAL (America)

Address	800 Corporate Way, Fremont, CA 94539, USA
Telephone	+1-812-282-3777
Fax	+1-510-608-4555
Web site	usa.asus.com

Technical Support

Telephone	+1-812-282-2787
Support fax	+1-812-284-0883
Online support	support.asus.com

ASUS COMPUTER GmbH (Germany and Austria)

Address	Harkort Str. 21-23, D-40880 Ratingen, Germany
Fax	+49-2102-959911
Web site	www.asus.de
Online contact	www.asus.de/sales

Technical Support

Telephone	+49-1805-010923*
Support Fax	+49-2102-9599-11
Online support	support.asus.com

* EUR 0.14/minute from a German fixed landline; EUR 0.42/minute from a mobile phone.

