

HP ProLiant DL385p Gen8 Server User Guide

Abstract

This document is for the person who installs, administers, and troubleshoots servers and storage systems. HP assumes you are qualified in the servicing of computer equipment and trained in recognizing hazards in products with hazardous energy levels.



Part Number: 661850-002
February 2013
Edition: 2

© Copyright 2012, 2013 Hewlett-Packard Development Company, L.P.

The information contained herein is subject to change without notice. The only warranties for HP products and services are set forth in the express warranty statements accompanying such products and services. Nothing herein should be construed as constituting an additional warranty. HP shall not be liable for technical or editorial errors or omissions contained herein.

Microsoft®, Windows®, and Windows Server® are U.S. registered trademarks of Microsoft Corporation.

Contents

Component identification	7
Front panel components	7
Front panel LEDs and buttons	9
Access the Systems Insight Display.....	10
Systems Insight Display LEDs	11
Systems Insight Display LED combinations.....	12
Rear panel components.....	13
Rear panel LEDs and buttons.....	14
Non-hot-plug PCIe riser board slot definitions	14
System board components	15
System maintenance switch.....	16
NMI functionality.....	17
DIMM slot locations	17
SAS and SATA device numbers.....	18
Drive LED definitions	19
PCIe riser cage LED	19
FBWC module LEDs (P222, P420, P421)	20
Hot-plug fans	21
Operations	23
Power up the server	23
Power down the server.....	23
Extend the server from the rack	23
Remove the server from the rack.....	24
Remove the access panel.....	25
Install the access panel.....	25
Access the product rear panel.....	25
Opening the cable management arm	25
Remove the fan cage	26
Remove the hot-plug fan	27
Remove the full-length expansion board.....	28
Remove the primary PCIe riser cage	29
Remove the secondary PCIe riser cage.....	30
Install the primary PCIe riser cage	31
Secure the primary PCIe riser cage full-length expansion board retainer	32
Secure the secondary PCIe riser cage full-length expansion board retainer.....	33
Remove the air baffle.....	34
Setup	36
Optional installation services	36
Rack planning resources.....	36
Optimum environment.....	36
Space and airflow requirements	37
Temperature requirements.....	37
Power requirements	38
Electrical grounding requirements	38
Connecting a DC power cable to a DC power source	38

Rack warnings	39
Identifying the contents of the server shipping carton.....	40
Installing hardware options.....	40
Installing the server into the rack.....	40
Installing the operating system.....	42
Powering on and selecting boot options	42
Registering the server.....	43
Hardware options installation.....	44
Introduction	44
Processor option.....	44
Memory options	52
HP SmartMemory	54
Memory subsystem architecture	55
Single, dual, and quad-rank DIMMs	55
DIMM identification	56
Memory configurations.....	57
General DIMM slot population guidelines	57
Installing a DIMM	58
Hot-plug hard drive options	59
Installing a hot-plug SAS or SATA hard drive	59
Removing a hot-plug SAS or SATA hard drive	60
Controller options.....	61
Installing the flash-backed write cache module.....	62
Installing the FBWC capacitor pack	63
Optical drive option	66
Redundant hot-plug power supply option	68
FlexibleLOM option	69
Expansion board options.....	71
Removing the expansion slot blanks	71
Installing a half-length expansion board	72
Installing a full-length expansion board.....	73
Secondary PCIe riser cage option.....	74
Hard drive cage option.....	76
2U rack bezel option	86
HP Trusted Platform Module option	86
Installing the Trusted Platform Module board	87
Retaining the recovery key/password	89
Enabling the Trusted Platform Module.....	89
Cabling	90
SAS hard drive cabling	90
Optical drive cabling.....	91
FBWC cabling	92
Chipset SATA cable option.....	93
150W PCIe power cable option	97
Software and configuration utilities	98
Server mode	98
HP product QuickSpecs.....	98
HP iLO Management Engine.....	98
HP iLO	98
Intelligent Provisioning.....	100
HP Insight Remote Support software	102

Scripting Toolkit	102
HP Service Pack for ProLiant	102
HP Smart Update Manager	103
HP ROM-Based Setup Utility	103
Using RBSU	104
Auto-configuration process	104
Boot options	105
Configuring AMP modes	105
Re-entering the server serial number and product ID	105
Utilities and features	106
Array Configuration Utility	106
Option ROM Configuration for Arrays	107
ROMPaq utility	107
Automatic Server Recovery	107
USB support	107
Redundant ROM support	108
Keeping the system current	108
Drivers	108
Software and firmware	109
Version control	109
HP operating systems and virtualization software support for ProLiant servers	109
HP Technology Service Portfolio	110
Change control and proactive notification	110
Troubleshooting	111
Troubleshooting resources	111
Battery replacement	112
Regulatory information	114
Safety and regulatory compliance	114
Turkey RoHS material content declaration	114
Ukraine RoHS material content declaration	114
Warranty information	114
Electrostatic discharge	115
Preventing electrostatic discharge	115
Grounding methods to prevent electrostatic discharge	115
Specifications	116
Environmental specifications	116
Mechanical specifications	116
Power supply specifications	116
HP 460 W CS Gold power supply (92% efficiency)	117
HP 460 W CS Platinum Plus power supply (94% efficiency)	117
HP 750 W CS Gold power supply (92% efficiency)	118
HP 750 W CS Platinum Plus power supply (94% efficiency)	118
HP 750 W 48V CS DC power supply (94% efficiency)	119
HP 1200 W CS Platinum Plus Power Supply (90% efficiency)	119
Support and other resources	121
Before you contact HP	121
HP contact information	121
Customer Self Repair	121
Acronyms and abbreviations	129

Documentation feedback	132
Index.....	133

Component identification

Front panel components

- 8 drive SFF configuration

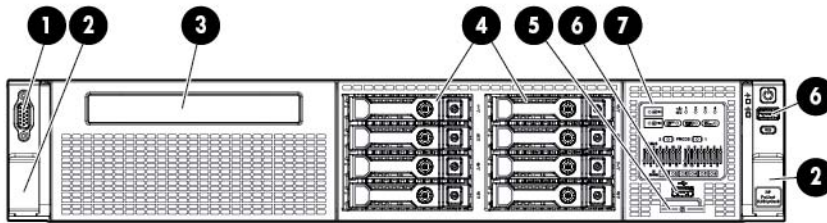

Item	Description
1	Video connector
2	Quick release levers (2)
3	SATA optical drive bay
4	SFF drive bays
5	Serial number label
6	USB connectors (2)
7	Systems Insight Display

- 16 drive SFF configuration (with optional drive cage)

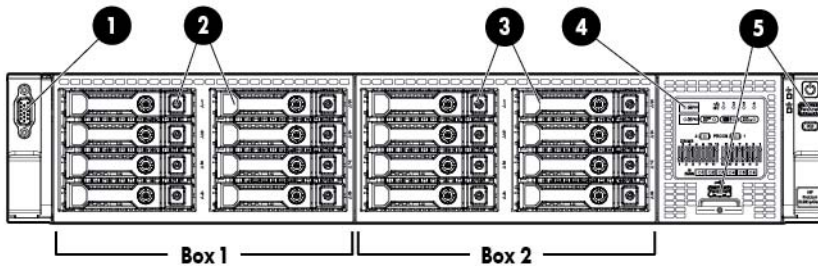

Item	Description
1	Video connector

Item	Description
2	Drive bays (box 1)
3	Drive bays (box 2)
4	Systems Insight Display
5	USB connectors (2)

- 25 SFF drive configuration

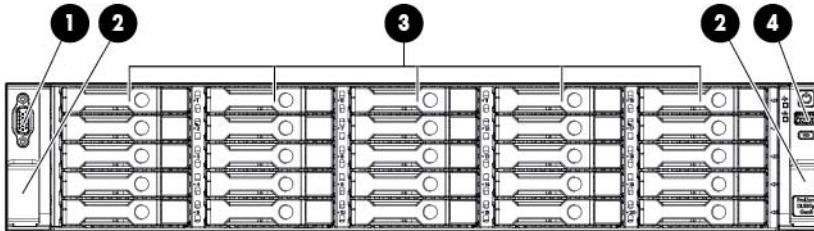

Item	Description
1	Video connector
2	Quick release levers (2)
3	Drive bays
4	USB connector

- 8 drive LFF configuration

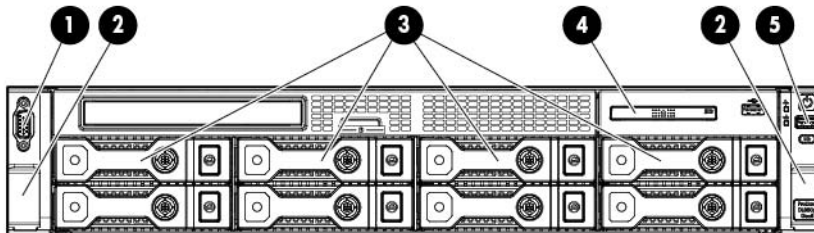

Item	Description
1	Video connector
2	Quick release levers (2)
3	Drive bays
4	Systems Insight Display
5	USB connector

- 12 drive LFF configuration

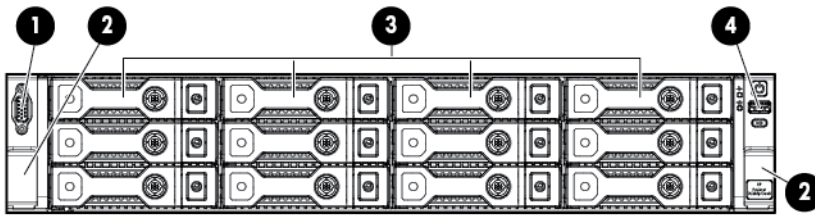

Item	Description
1	Video connector
2	Quick release levers (2)
3	Drive bays
4	USB connector

Front panel LEDs and buttons

- SFF

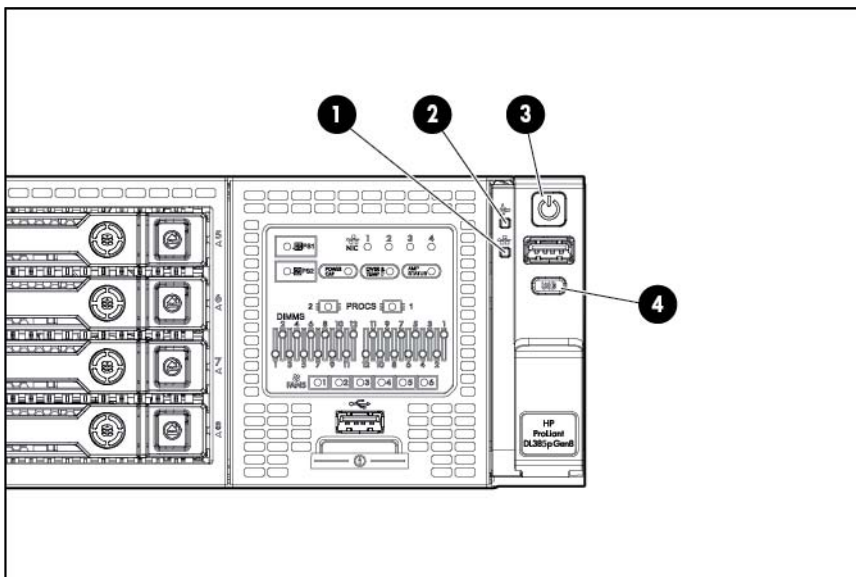

- LFF

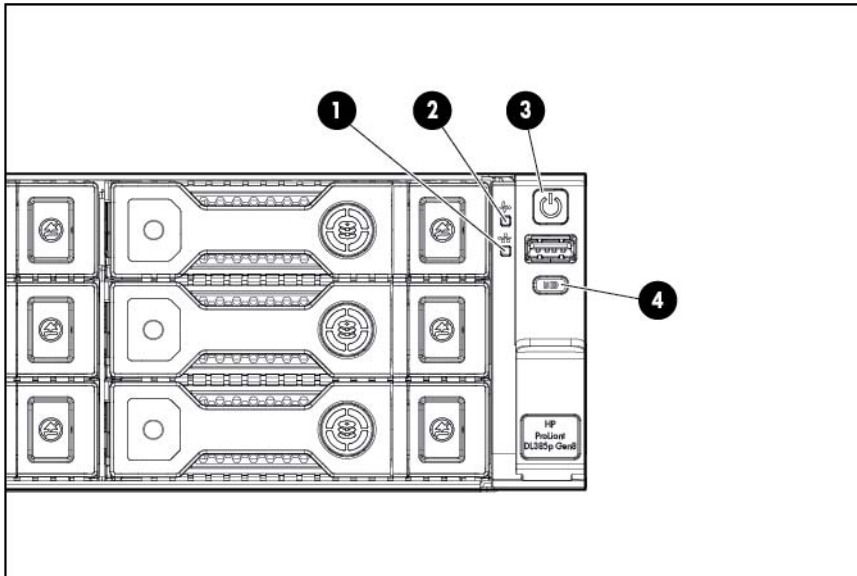

Item	Description	Status
1	NIC status LED	Solid green = Link to network Flashing green (1 Hz/cycle per sec) = Network active Off = No network activity
2	Health LED	Solid green = Normal Flashing amber = System degraded Flashing red (1 Hz/cycle per sec) = System critical Fast-flashing red (4 Hz/cycles per sec) = Power fault*
3	Power On/Standby button and system power LED	Solid green = System on Flashing green (1 Hz/cycle per sec) = Performing power on sequence Solid amber = System in standby Off = No power present**
4	UID button/LED	Solid blue = Activated Flashing blue (1 Hz/cycle per sec) = Remote management or firmware upgrade in progress Off = Deactivated

*To identify components in a degraded or critical state, see the Systems Insight Display LEDs, check iLO/BIOS logs, and reference the server troubleshooting guide.

**Facility power is not present, power cord is not attached, no power supplies are installed, power supply failure has occurred, or the power button cable is disconnected.

Access the Systems Insight Display

To access the HP Systems Insight Display in a server with an 8-drive LFF configuration:

1. Press and release the panel.

- After the display fully ejects, rotate the display downward to view the LEDs.

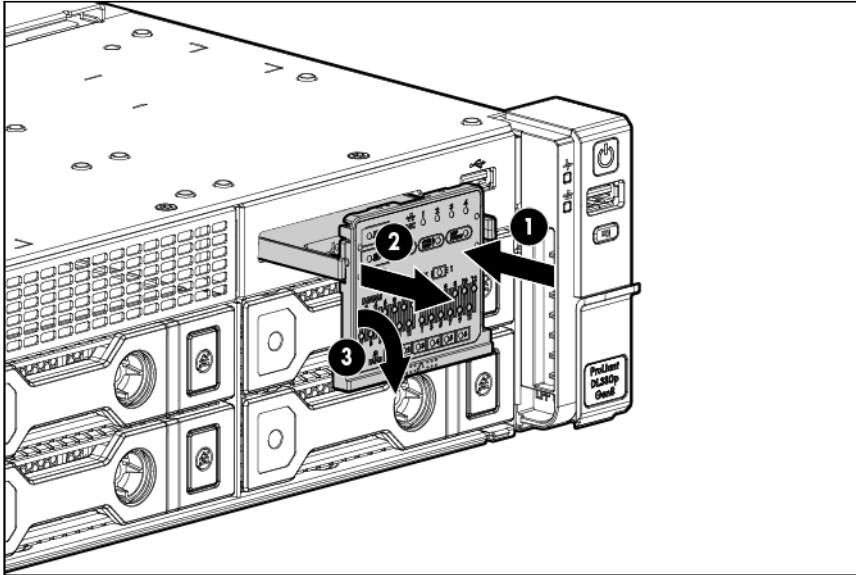

Systems Insight Display LEDs

The HP Systems Insight Display LEDs represent the system board layout. The display, available on 8 SFF, 16 SFF, and 8 LFF configurations, enables diagnosis with the access panel installed.

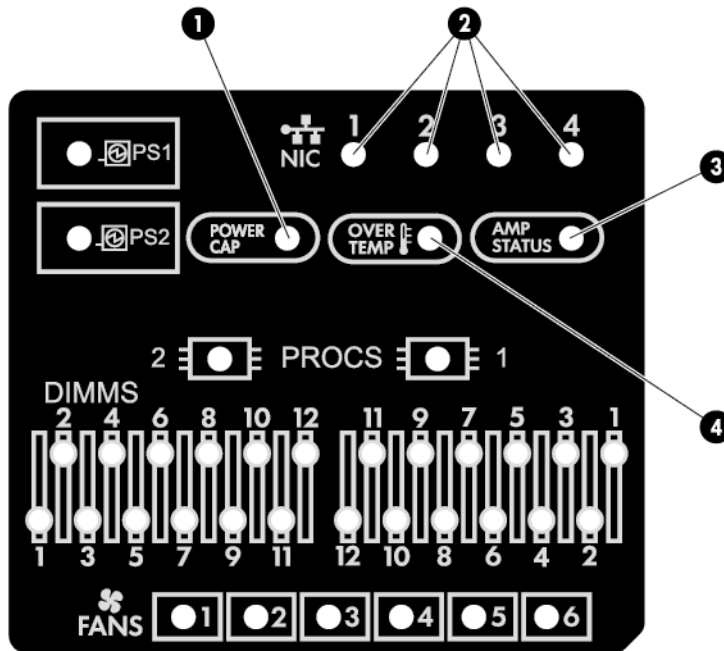

Item	Description	Status
1	Power cap	Off = System is in standby, or no cap is set. Solid green = Power cap applied

Item	Description	Status
2	NIC link/activity	Off = No link to network. If the power is off, view the rear panel RJ-45 LEDs for status. Flashing green = Network link and activity Solid green = Network link
3	AMP status	Off = AMP modes disabled Solid green = AMP mode enabled Solid amber = Failover Flashing amber = Invalid configuration
4	Over temp	Off = Normal Solid amber = High system temperature detected
—	All other LEDs	Off = Normal Amber = Failure For more information on the activation of these LEDs, see "Systems Insight Display LED combinations (on page 12)."

Systems Insight Display LED combinations

When the health LED on the front panel illuminates either amber or red, the server is experiencing a health event. Combinations of illuminated Systems Insight Display LEDs, the system power LED, and the health LED indicate system status.

Systems Insight Display LED and color	Health LED	System power LED	Status
Processor (amber)	Red	Amber	One or more of the following conditions may exist: <ul style="list-style-type: none"> Processor in socket X has failed. Processor X is not installed in the socket. Processor X is unsupported. ROM detects a failed processor during POST.
Processor (amber)	Amber	Green	Processor in socket X is in a pre-failure condition.
DIMM (amber)	Red	Green	One or more DIMMs have failed.
DIMM (amber)	Amber	Green	DIMM in slot X is in a pre-failure condition.
Over temp (amber)	Amber	Green	The Health Driver has detected a cautionary temperature level.
Over temp (amber)	Red	Amber	The server has detected a hardware critical temperature level.
Fan (amber)	Amber	Green	One fan has failed or has been removed.
Fan (amber)	Red	Green	Two or more fans have failed or been removed.
Power supply (amber)	Red	Amber	One or more of the following conditions may exist: <ul style="list-style-type: none"> Only one power supply is installed and that power supply is in standby.

Systems Insight Display LED and color	Health LED	System power LED	Status
			<ul style="list-style-type: none"> Power supply fault System board fault
Power supply (amber)	Amber	Green	One or more of the following conditions may exist: <ul style="list-style-type: none"> Redundant power supply is installed and only one power supply is functional. AC power cord is not plugged into redundant power supply. Redundant power supply fault Power supply mismatch at POST or power supply mismatch through hot-plug addition
Power cap (off)	—	Amber	Standby
Power cap (off)	—	Flashing green	Waiting for power
Power cap (off)	—	Green	Power is available.



IMPORTANT: If more than one DIMM slot LED is illuminated, further troubleshooting is required. Test each bank of DIMMs by removing all other DIMMs. Isolate the failed DIMM by replacing each DIMM in a bank with a known working DIMM.

Rear panel components

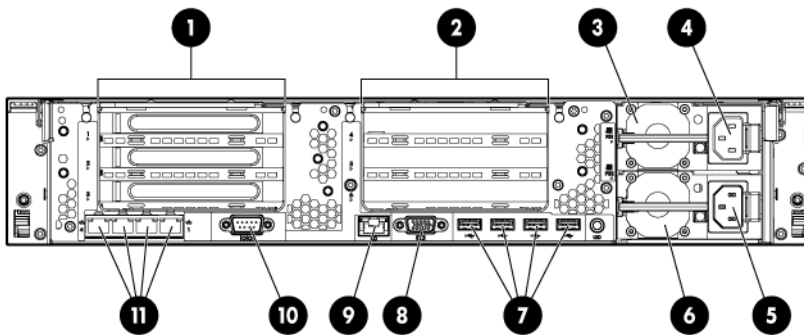

Item	Description
1	PCIe slots 1–3 (top to bottom)
2	PCIe slots 4–6, optional (top to bottom)
3	Power supply 1 (PS1)
4	PS1 power connector
5	PS2 power connector, optional
6	Power supply 2 (PS2), optional
7	USB connectors (4)
8	Video connector
9	iLO connector
10	Serial connector
11	FlexibleLOM ports (Shown: 4x1Gb/Optional: 2x10Gb); port 1 on right side

Rear panel LEDs and buttons

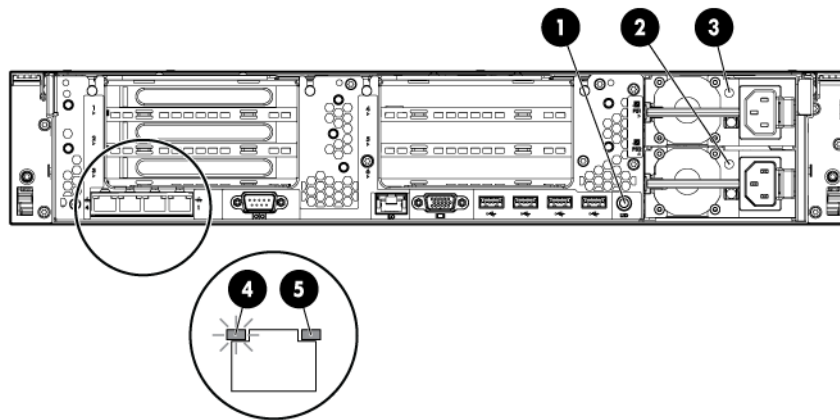

Item	Description	Status
1	UID LED/button	Off = Deactivated Solid blue = Activated Flashing blue = System being managed remotely
2	Power supply 2 LED	Off = System is off or power supply has failed. Solid green = Normal
3	Power supply 1 LED	Off = System is off or power supply has failed. Solid green = Normal
4	NIC activity LED	Off = No network activity Solid green = Link to network Flashing green = Network activity
5	NIC link LED	Off = No network link Green = Network link

Non-hot-plug PCIe riser board slot definitions

Primary Slot - form factor	PCIe 2 riser slot description	Secondary Slot - form factor	PCIe 2 x16 riser slot description
1 - FL/FH	PCIe2 x16 (8,4,1)	4 - FL/FH	PCIe2 x16 (16, 8, 4, 1)
2 - HL/FH	PCIe2 x8 (8,4,1)	5 - HL/FH	PCIe2 x16 (8, 4, 1)
3 - HL/FH	PCIe2 x8 (4,1)	6 - HL/FH	PCIe2 x8 (8, 4, 1)

Notes:

- "Primary" denotes the riser cage is installed in the primary riser connector.
- "Secondary" denotes the riser cage is installed in the secondary riser connector.
- Installing the riser cages listed in the table above in either the primary or secondary riser connectors determines the form factor of the PCI cards supported by those riser cages.
- FL/FH denotes full-length, full-height. HL/FH denotes half-length, full-height. LP denotes low profile.

Item	Description
11	Processor 2 DIMM slots
12	Second drive cage
13	Fan connector 1
14	NMI jumper
15	Front video connector
16	Discovery services connector
17	System maintenance switch
18	SATA optical drive connector
19	SATA drive port 1
20	Power supply backplane connector
21	USB connector
22	SD card slot
23	Secondary (processor 2) PCIe riser connector
24	Processor 2 socket
25	System battery
26	TPM connector
27	Primary (processor 1) PCIe riser connector
28	Processor 1 socket
29	FlexibleLOM
30	SAS port 1i
31	SAS port 2i
32	SAS cache module connector

System maintenance switch

Position	Default	Function
S1	Off	Off = HP iLO security is enabled. On = HP iLO security is disabled.
S2	Off	Off = System configuration can be changed. On = System configuration is locked.
S3	Off	Reserved
S4	Off	Reserved
S5	Off	Off = Power-on password is enabled. On = Power-on password is disabled.
S6	Off	Off = No function On = ROM reads system configuration as invalid.
S7	—	Reserved
S8	—	Reserved
S9	—	Reserved
S10	—	Reserved
S11	—	Reserved
S12	—	Reserved

To access redundant ROM, set S1, S5, and S6 to on.

When the system maintenance switch position 6 is set to the On position, the system is prepared to erase all system configuration settings from both CMOS and NVRAM.

CAUTION: Clearing CMOS and/or NVRAM deletes configuration information. Be sure to properly configure the server or data loss could occur.

NMI functionality

An NMI crash dump enables administrators to create crash dump files when a system is hung and not responding to traditional debug mechanisms.

Crash dump log analysis is an essential part of diagnosing reliability problems, such as hangs in operating systems, device drivers, and applications. Many crashes freeze a system, and the only available action for administrators is to cycle the system power. Resetting the system erases any information that could support problem analysis, but the NMI feature preserves that information by performing a memory dump before a hard reset.

To force the OS to invoke the NMI handler and generate a crash dump log, the administrator can use the iLO Virtual NMI feature.

For more information, see the white paper on the HP website (<http://h20000.www2.hp.com/bc/docs/support/SupportManual/c00797875/c00797875.pdf>).

DIMM slot locations

DIMM slots are numbered sequentially (1 through 12) for each processor. The supported AMP modes use the letter assignments for population guidelines.

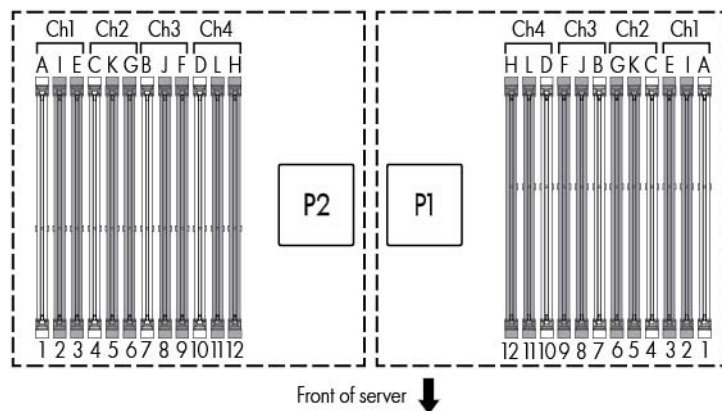

SAS and SATA device numbers

- 8 SFF device bay numbering

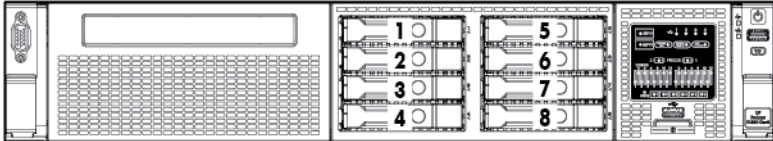

- 16 SFF device bay numbering

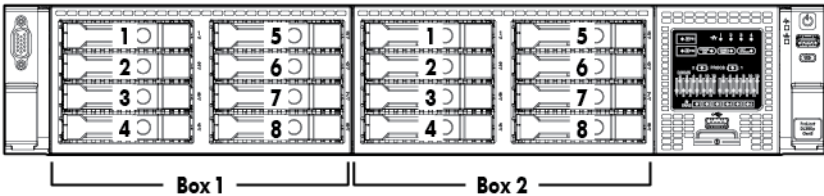

- 25 SFF device bay numbering

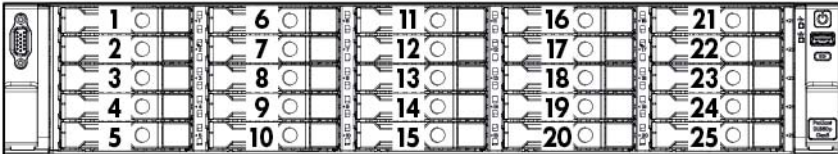

- 8 LFF device bay numbering

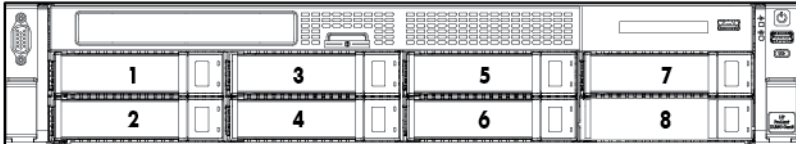

- 12 LFF device bay numbering

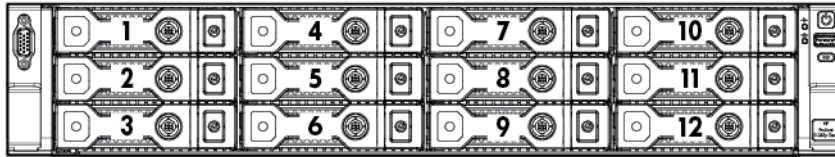

Drive LED definitions

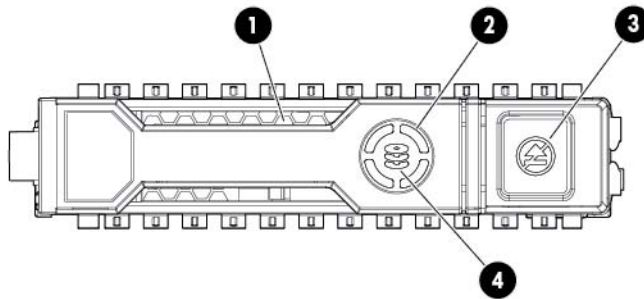

Item	LED	Status	Definition
1	Locate	Solid blue	The drive is being identified by a host application.
		Flashing blue	The drive carrier firmware is being updated or requires an update.
2	Activity ring	Rotating green	Drive activity
		Off	No drive activity
3	Do not remove	Solid white	Do not remove the drive. Removing the drive causes one or more of the logical drives to fail.
		Off	Removing the drive does not cause a logical drive to fail.
4	Drive status	Solid green	The drive is a member of one or more logical drives.
		Flashing green	The drive is rebuilding or performing a RAID migration, stripe size migration, capacity expansion, or logical drive extension, or is erasing.
		Flashing amber/green	The drive is a member of one or more logical drives and predicts the drive will fail.
		Flashing amber	The drive is not configured and predicts the drive will fail.
		Solid amber	The drive has failed.
		Off	The drive is not configured by a RAID controller.

PCIe riser cage LED



CAUTION: To prevent damage to the server or expansion boards, power down the server and remove all AC power cords before removing or installing the PCIe riser cage.

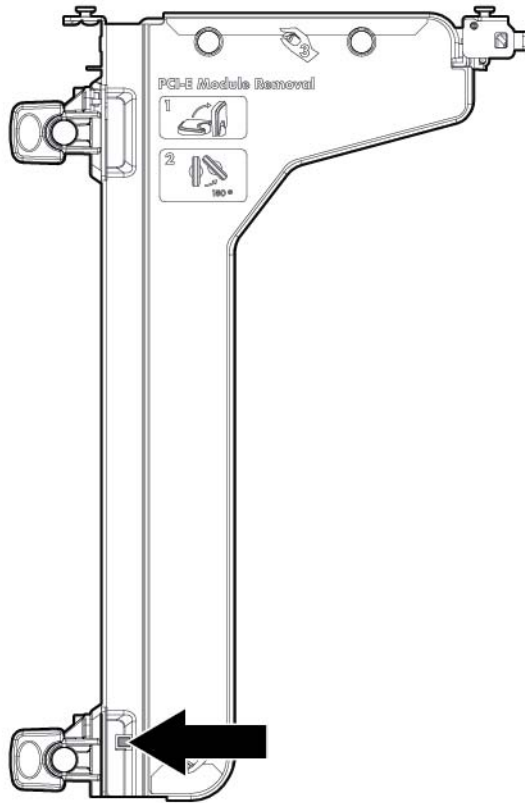

Status
On = AC power is connected.
Off = AC power is disconnected.
Missing = Riser cage is not installed, or power might not be connected.

FBWC module LEDs (P222, P420, P421)

The FBWC module has three single-color LEDs (one amber and two green). The LEDs are duplicated on the reverse side of the cache module to facilitate status viewing.

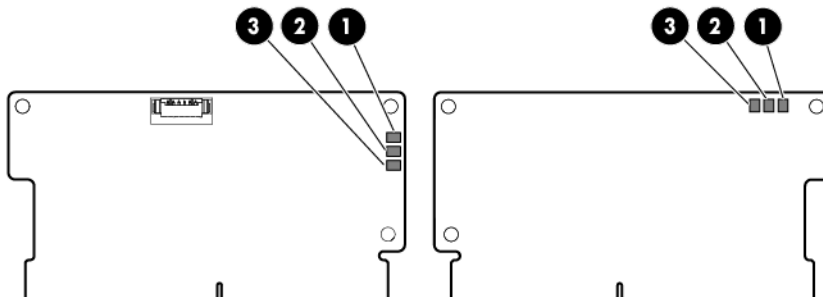

1 - Amber	2 - Green	3 - Green	Interpretation
Off	Off	Off	The cache module is not powered.
Off	Flashing 0.5 Hz	Flashing 0.5 Hz	The cache microcontroller is executing from within its boot loader and receiving new flash code from the host controller.
Off	Flashing 1 Hz	Flashing 1 Hz	The cache module is powering up, and the capacitor pack is charging.
Off	Off	Flashing 1 Hz	The cache module is idle, and the capacitor pack is charging.
Off	Off	On	The cache module is idle, and the capacitor pack is charged.
Off	On	On	The cache module is idle, the capacitor pack is charged, and the cache contains data that has not yet been written to the drives.
Off	Flashing 1 Hz	Off	A backup is in progress.
Off	On	Off	The current backup is complete with no errors.
Flashing 1 Hz	Flashing 1 Hz	Off	The current backup failed, and data has been lost.
Flashing 1 Hz	Flashing 1 Hz	On	A power error occurred during the previous or current boot. Data may be corrupt.
Flashing 1 Hz	On	Off	An overtemperature condition exists.
Flashing 2 Hz	Flashing 2 Hz	Off	The capacitor pack is not attached.
Flashing 2 Hz	Flashing 2 Hz	On	The capacitor has been charging for 10 minutes, but has not reached sufficient charge to perform a full backup.
On	On	Off	The current backup is complete, but power fluctuations occurred during the backup.
On	On	On	The cache module microcontroller has failed.

Hot-plug fans



CAUTION: To avoid damage to server components, fan blanks must be installed in fan bays 1 and 2 in a single-processor configuration.

The only two valid fan configurations are listed in the following table.

Configuration	Fan bay 1	Fan bay 2	Fan bay 3	Fan bay 4	Fan bay 5	Fan bay 6
1 processor	Fan blank	Fan blank	Fan	Fan	Fan	Fan
2 processors	Fan	Fan	Fan	Fan	Fan	Fan

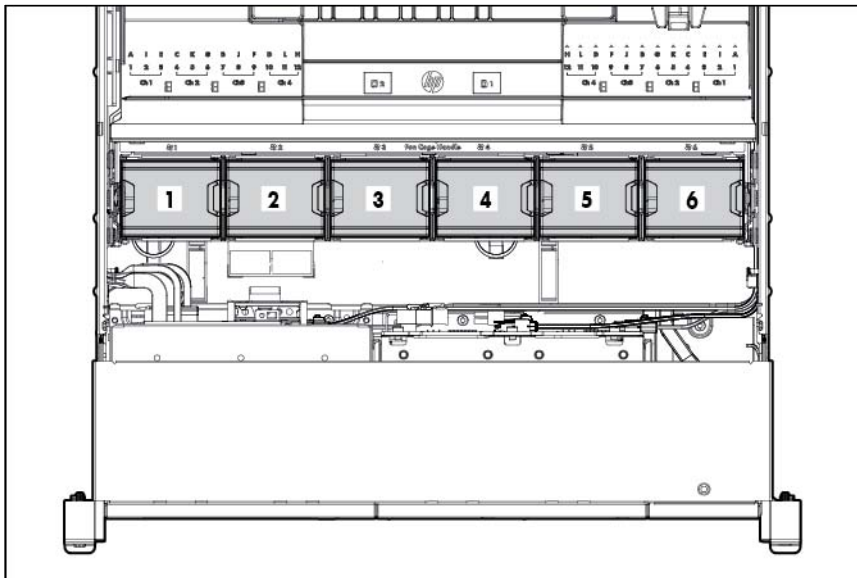

For a single-processor configuration, four fans and two blanks are required in specific fan bays for redundancy. A fan failure or missing fan causes a loss of redundancy. A second fan failure or missing fan causes an orderly shutdown of the server.

Installing more than the required number of fans in a single-processor configuration is not a supported configuration.

For a dual-processor configuration, six fans are required for redundancy. A fan failure or missing fan causes a loss of redundancy. A second fan failure or missing fan causes an orderly shutdown of the server.

The server supports variable fan speeds. The fans operate at minimum speed until a temperature change requires a fan speed increase to cool the server. The server shuts down during the following temperature-related scenarios:

- At POST and in the OS, HP iLO performs an orderly shutdown if a cautionary temperature level is detected. If the server hardware detects a critical temperature level before an orderly shutdown occurs, the server performs an immediate shutdown.
- When the Thermal Shutdown feature is disabled in RBSU, HP iLO does not perform an orderly shutdown when a cautionary temperature level is detected. Disabling this feature does not disable the server hardware from performing an immediate shutdown when a critical temperature level is detected.

CAUTION: A thermal event can damage server components when the Thermal Shutdown feature is disabled in RBSU.

Operations

Power up the server

To power up the server, press the Power On/Standby button.

Power down the server

Before powering down the server for any upgrade or maintenance procedures, perform a backup of critical server data and programs.



IMPORTANT: When the server is in standby mode, auxiliary power is still being provided to the system.

To power down the server, use one of the following methods:

- Press and release the Power On/Standby button.
This method initiates a controlled shutdown of applications and the OS before the server enters standby mode.
- Press and hold the Power On/Standby button for more than 4 seconds to force the server to enter standby mode.
This method forces the server to enter standby mode without properly exiting applications and the OS. If an application stops responding, you can use this method to force a shutdown.
- Use a virtual power button selection through HP iLO.
This method initiates a controlled remote shutdown of applications and the OS before the server enters standby mode.

Before proceeding, verify the server is in standby mode by observing that the system power LED is amber.

Extend the server from the rack

1. Pull down the quick release levers on each side of the server.
2. Extend the server from the rack.



WARNING: To reduce the risk of personal injury or equipment damage, be sure that the rack is adequately stabilized before extending a component from the rack.

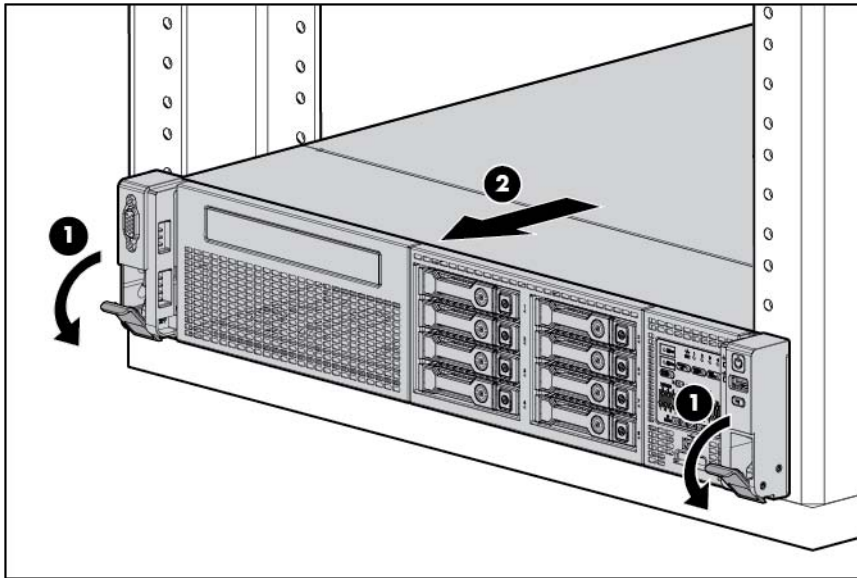

3. After performing the installation or maintenance procedure, slide the server back into the rack, and then press the server firmly into the rack to secure it in place.

⚠ WARNING: To reduce the risk of personal injury, be careful when pressing the server rail-release latches and sliding the server into the rack. The sliding rails could pinch your fingers.

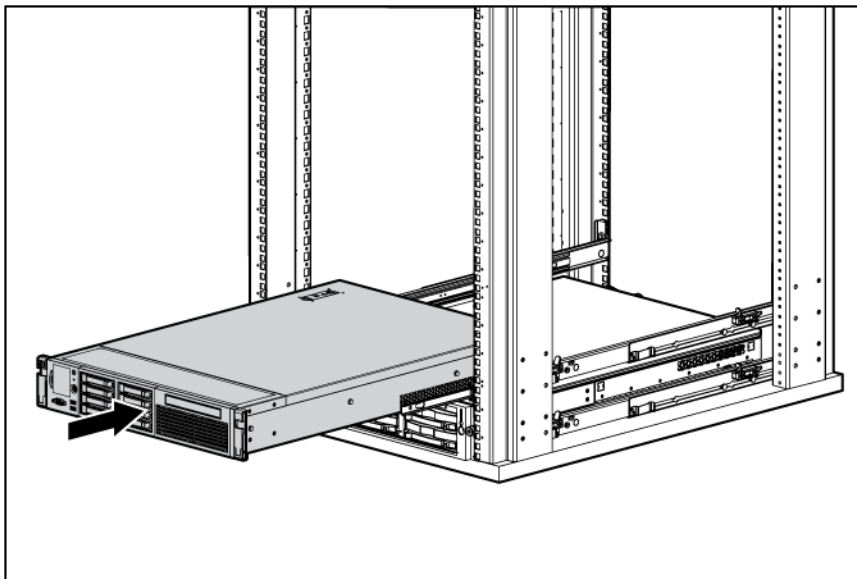

Remove the server from the rack

To remove the server from an HP, Compaq branded, telco, or third-party rack:

1. Power down the server (on page 23).
2. Extend the server from the rack (on page 23).
3. Disconnect the cabling and remove the server from the rack. For more information, refer to the documentation that ships with the rack mounting option.
4. Place the server on a sturdy, level surface.

Remove the access panel

⚠ WARNING: To reduce the risk of personal injury from hot surfaces, allow the drives and the internal system components to cool before touching them.

⚠ CAUTION: For proper cooling, do not operate the server without the access panel, baffles, expansion slot covers, or blanks installed. If the server supports hot-plug components, minimize the amount of time the access panel is open.

To remove the component:

1. Power down the server if performing a non-hot-plug installation or maintenance procedure ("[Power down the server](#)" on page 23).
2. Extend the server from the rack (on page 23).
3. Use the T-15 Torx screwdriver to loosen the security screw on the hood latch.
4. Lift up on the hood latch handle, and then remove the access panel.

Install the access panel

1. Place the access panel on top of the server with the hood latch open. Allow the panel to extend past the rear of the server approximately 1.25 cm (0.5 in).
2. Push down on the hood latch. The access panel slides to a closed position.
3. Use the T-15 Torx screwdriver to tighten the security screw on the hood latch.

Access the product rear panel

Opening the cable management arm

To access the server rear panel:

1. Release the cable management arm.

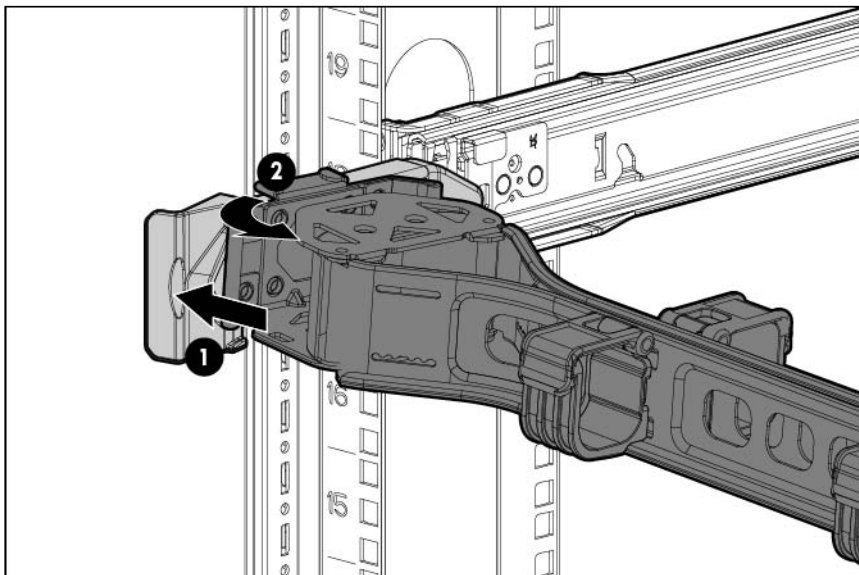

2. Open the cable management arm. Note that the cable management arm can be right-mounted or left-mounted.

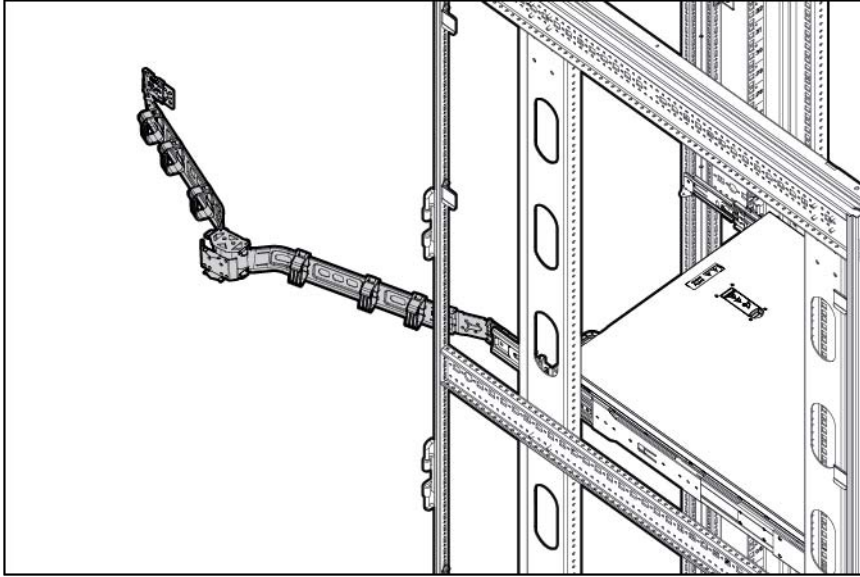

Remove the fan cage

To remove the component:

1. Power down the server (on page 23).
2. Remove all power:
 - a. Disconnect each power cord from the power source.
 - b. Disconnect each power cord from the server.
3. Extend or remove the server from the rack ("[Remove the server from the rack](#)" on page 24, "[Extend the server from the rack](#)" on page 23).
4. Remove the access panel (on page 25).
5. Remove the air baffle (on page 34).

6. Remove the fan cage.

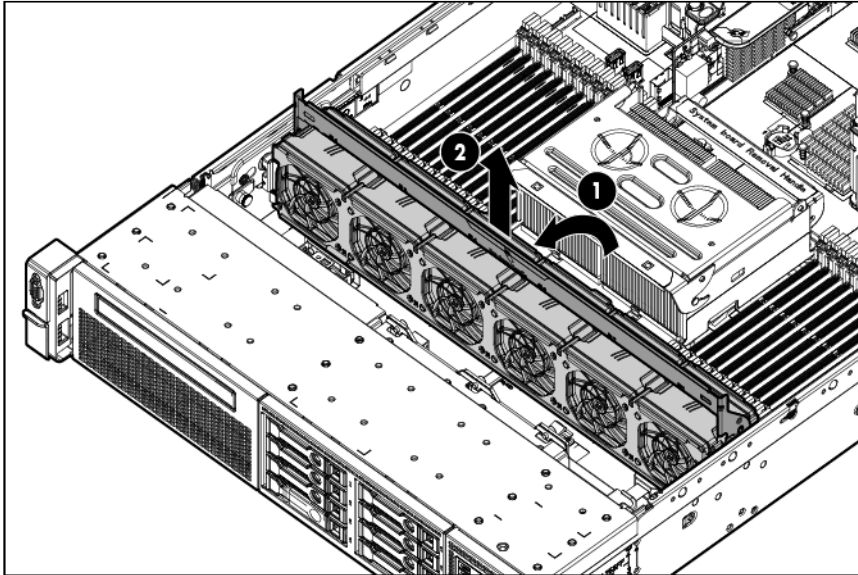

CAUTION: Do not operate the server for long periods with the access panel open or removed. Operating the server in this manner results in improper airflow and improper cooling that can lead to thermal damage.



IMPORTANT: For optimum cooling, install fans in all primary fan locations. For more information, refer to the fan locations table ("[Hot-plug fans](#)" on page 21).

To install the component, reverse the removal procedure.

Remove the hot-plug fan

To remove the component:

1. Extend or remove the server from the rack ("[Remove the server from the rack](#)" on page 24, "[Extend the server from the rack](#)" on page 23).
2. Remove the access panel (on page 25).

3. Remove the fan.

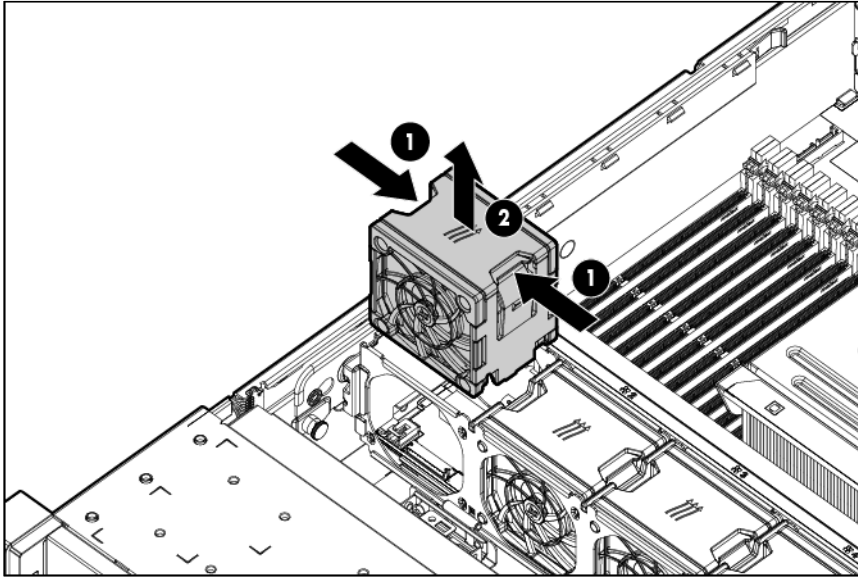

CAUTION: Do not operate the server for long periods with the access panel open or removed. Operating the server in this manner results in improper airflow and improper cooling that can lead to thermal damage.

IMPORTANT: For optimum cooling, install fans in all primary fan locations. For more information, refer to the fan locations table ("[Hot-plug fans](#)" on page 21).

To install the component, reverse the removal procedure.

Remove the full-length expansion board

CAUTION: To prevent damage to the server or expansion boards, power down the server and remove all AC power cords before removing or installing the PCIe riser cage.

To remove the component:

1. Power down the server (on page 23).
2. Remove all power:
 - a. Disconnect each power cord from the power source.
 - b. Disconnect each power cord from the server.
3. Extend the server from the rack (on page 23).
4. Remove the access panel (on page 25).

5. If a full-length expansion board is installed in slot 1, release the full-length expansion board retainer, and then remove the primary PCIe riser cage.

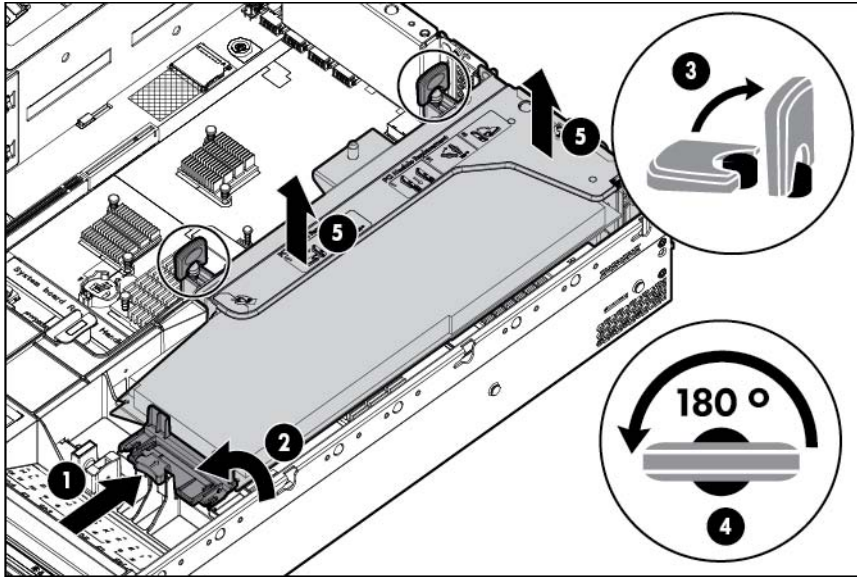

6. If a full-length expansion board is installed in slot 4, release the full-length expansion board retainer, and then remove the secondary PCIe riser cage.

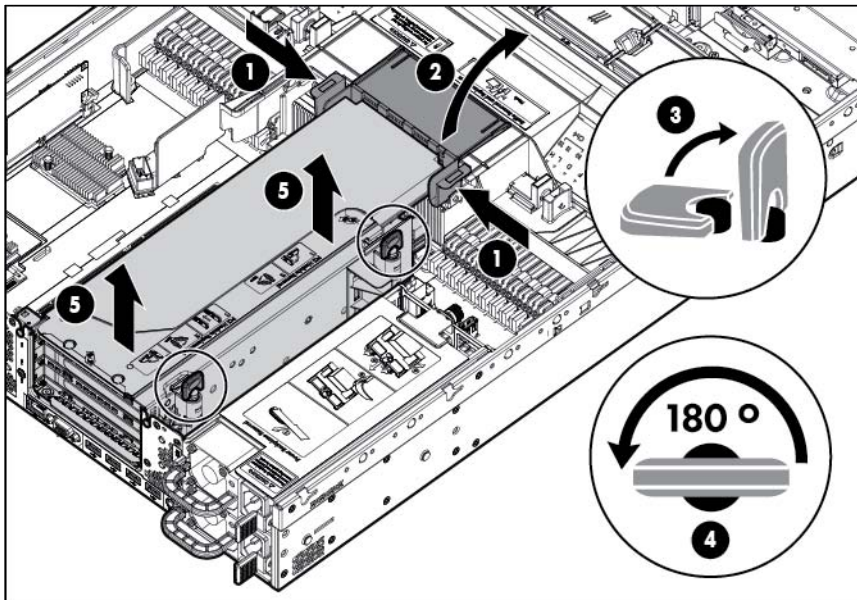

7. Remove the full-length expansion board.

To install the component, reverse the removal procedure.

Remove the primary PCIe riser cage

CAUTION: To prevent damage to the server or expansion boards, power down the server and remove all AC power cords before removing or installing the PCIe riser cage.

1. Power down the server (on page 23).
2. Remove all power:

- a. Disconnect each power cord from the power source.
 - b. Disconnect each power cord from the server.
3. Extend the server from the rack (on page 23).
4. Remove the access panel (on page 25).
5. Remove any installed full-length expansion boards.
6. Remove the PCIe riser cage.

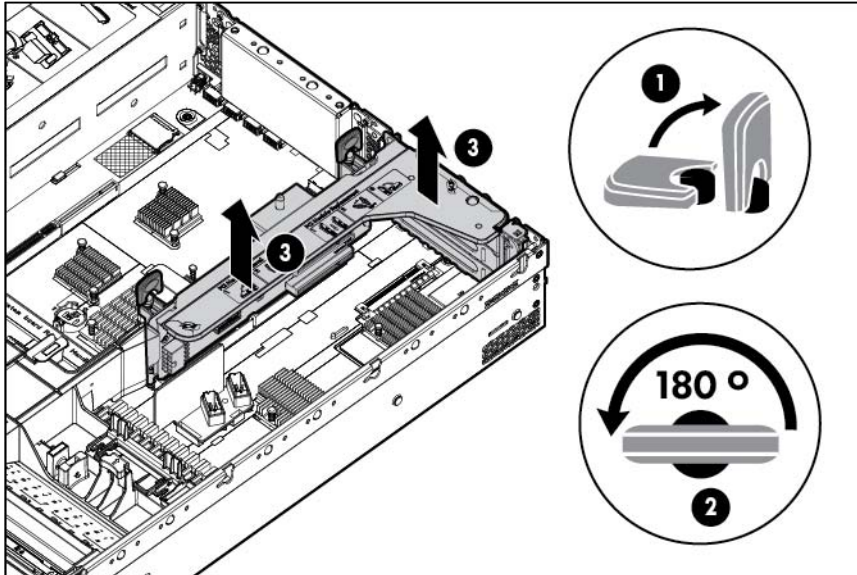

To install the component, reverse the removal procedure.

Remove the secondary PCIe riser cage



CAUTION: To prevent damage to the server or expansion boards, power down the server and remove all AC power cords before removing or installing the PCIe riser cage.

To remove the component:

1. Power down the server (on page 23).
2. Remove all power:
 - a. Disconnect each power cord from the power source.
 - b. Disconnect each power cord from the server.
3. Extend the server from the rack (on page 23).
4. Remove the access panel (on page 25).

5. If a full-length expansion board is installed in slot 4, release the full-length expansion board retainer, and then remove the PCIe riser cage.

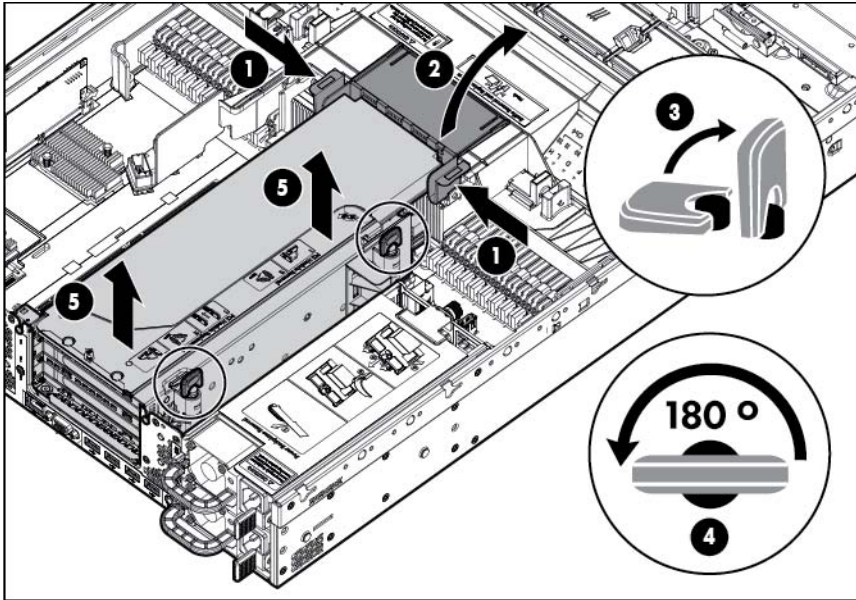

To install the component, reverse the removal procedure.

Install the primary PCIe riser cage



WARNING: To reduce the risk of personal injury, electric shock, or damage to the equipment, remove the power cord to remove power from the server. The front panel Power On/Standby button does not completely shut off system power. Portions of the power supply and some internal circuitry remain active until AC power is removed.

1. Power down the server (on page 23).
2. Remove all power:
 - a. Disconnect each power cord from the power source.
 - b. Disconnect each power cord from the server.
3. Extend the server from the rack (on page 23).
4. Remove the access panel (on page 25).

5. Install the PCIe riser cage.

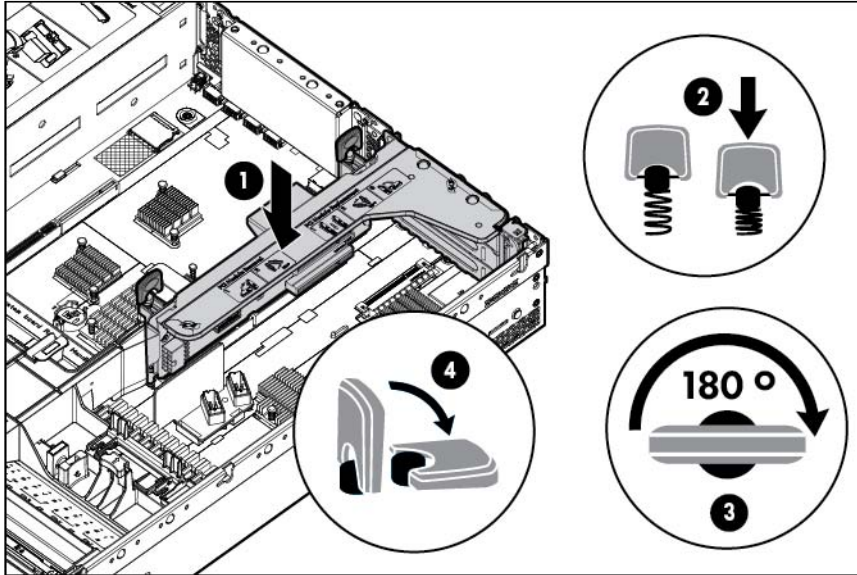

6. Install the access panel (on page 25).
7. Install the server into the rack ("[Installing the server into the rack](#)" on page 40).
8. Connect each power cord to the server.
9. Connect each power cord to the power source.
10. Power up the server (on page 23).

Secure the primary PCIe riser cage full-length expansion board retainer

1. Power down the server (on page 23).
2. Remove all power:
 - a. Disconnect each power cord from the power source.
 - b. Disconnect each power cord from the server.
3. Extend the server from the rack (on page 23).
4. Remove the access panel (on page 25).
5. Install a full-length expansion board ("[Installing a full-length expansion board](#)" on page 73).
6. Install the primary PCIe riser cage (on page 31).

7. Secure the full-length expansion board retainer.

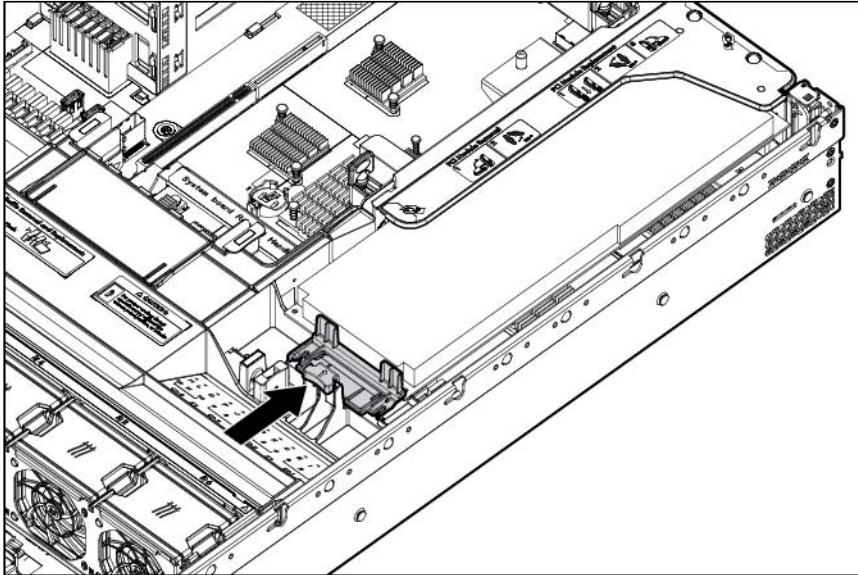

8. Install the access panel (on page 25).
9. Install the server into the rack ("Installing the server into the rack" on page 40).
10. Connect each power cord to the server.
11. Connect each power cord to the power source.
12. Power up the server (on page 23).

Secure the secondary PCIe riser cage full-length expansion board retainer

1. Power down the server (on page 23).
2. Remove all power:
 - a. Disconnect each power cord from the power source.
 - b. Disconnect each power cord from the server.
3. Extend the server from the rack (on page 23).
4. Remove the access panel (on page 25).
5. Install a full-length expansion board ("Installing a full-length expansion board" on page 73).
6. Install the secondary PCIe riser cage ("Secondary PCIe riser cage option" on page 74).

7. Secure the full-length expansion board retainer.

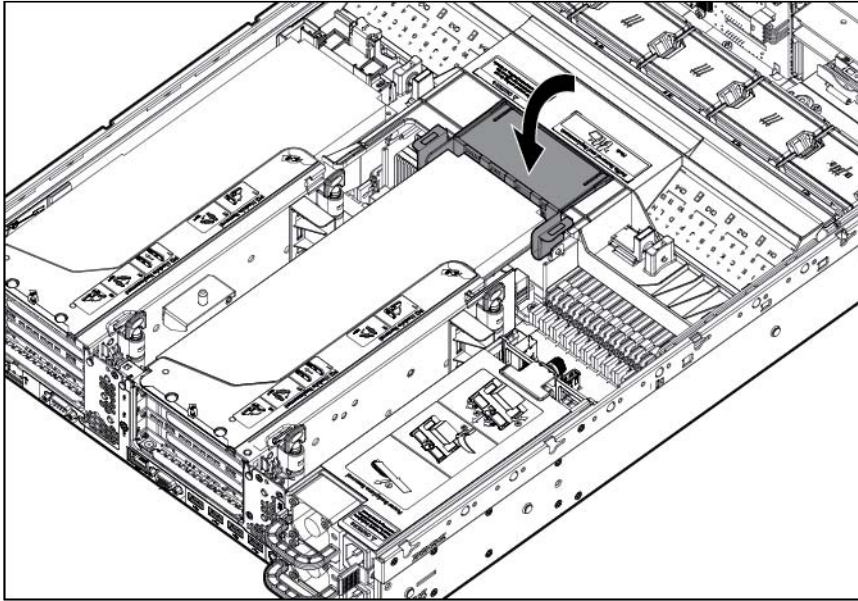

8. Install the access panel (on page 25).
9. Install the server into the rack ("Installing the server into the rack" on page 40).
10. Connect each power cord to the server.
11. Connect each power cord to the power source.
12. Power up the server (on page 23).

Remove the air baffle

CAUTION: For proper cooling, do not operate the server without the access panel, baffles, expansion slot covers, or blanks installed. If the server supports hot-plug components, minimize the amount of time the access panel is open.

To remove the component:

1. Power down the server (on page 23).
2. Remove all power:
 - a. Disconnect each power cord from the power source.
 - b. Disconnect each power cord from the server.
3. Extend or remove the server from the rack ("Remove the server from the rack" on page 24, "Extend the server from the rack" on page 23).
4. Remove the access panel (on page 25).

CAUTION: Do not detach the cable that connects the battery pack to the cache module. Detaching the cable causes any unsaved data in the cache module to be lost.

IMPORTANT: It is necessary to remove the PCIe riser cage only if there is a full-length expansion board installed.

5. If a full-length expansion board is installed in the primary PCIe riser cage, release the expansion board retainer and remove the primary PCIe riser cage (on page 29).

6. If a full-length expansion board is installed in the secondary PCIe riser cage, release the expansion board retainer and remove the secondary PCIe riser cage (on page 30).
7. Remove the air baffle.

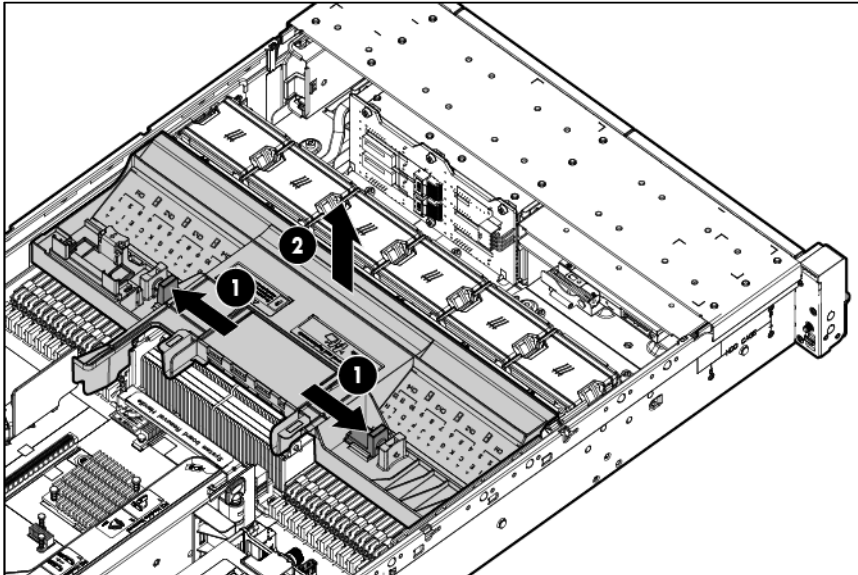

To install the component, reverse the removal procedure.

Setup

Optional installation services

Delivered by experienced, certified engineers, HP Care Pack services help you keep your servers up and running with support packages tailored specifically for HP ProLiant systems. HP Care Packs let you integrate both hardware and software support into a single package. A number of service level options are available to meet your needs.

HP Care Pack Services offer upgraded service levels to expand your standard product warranty with easy-to-buy, easy-to-use support packages that help you make the most of your server investments. Some of the Care Pack services are:

- Hardware support
 - 6-Hour Call-to-Repair
 - 4-Hour 24x7 Same Day
 - 4-Hour Same Business Day
- Software support
 - Microsoft®
 - Linux
 - HP ProLiant Essentials (HP SIM and RDP)
 - VMware
- Integrated hardware and software support
 - Critical Service
 - Proactive 24
 - Support Plus
 - Support Plus 24
- Startup and implementation services for both hardware and software

For more information on HP Care Pack Services, see the HP website (<http://www.hp.com/services/cairepack>).

Rack planning resources

The rack resource kit ships with all HP branded or Compaq branded 9000, 10000, and H9 series racks. For more information on the content of each resource, see the rack resource kit documentation.

Optimum environment

When installing the server in a rack, select a location that meets the environmental standards described in this section.

Space and airflow requirements

To allow for servicing and adequate airflow, observe the following space and airflow requirements when deciding where to install a rack:

- Leave a minimum clearance of 63.5 cm (25 in) in front of the rack.
- Leave a minimum clearance of 76.2 cm (30 in) behind the rack.
- Leave a minimum clearance of 121.9 cm (48 in) from the back of the rack to the back of another rack or row of racks.

HP servers draw in cool air through the front door and expel warm air through the rear door. Therefore, the front and rear rack doors must be adequately ventilated to allow ambient room air to enter the cabinet, and the rear door must be adequately ventilated to allow the warm air to escape from the cabinet.



CAUTION: To prevent improper cooling and damage to the equipment, do not block the ventilation openings.

When vertical space in the rack is not filled by a server or rack component, the gaps between the components cause changes in airflow through the rack and across the servers. Cover all gaps with blanking panels to maintain proper airflow.



CAUTION: Always use blanking panels to fill empty vertical spaces in the rack. This arrangement ensures proper airflow. Using a rack without blanking panels results in improper cooling that can lead to thermal damage.

The 9000 and 10000 Series Racks provide proper server cooling from flow-through perforations in the front and rear doors that provide 64 percent open area for ventilation.



CAUTION: When using a Compaq branded 7000 series rack, install the high airflow rack door insert (PN 327281-B21 for 42U rack, PN 157847-B21 for 22U rack) to provide proper front-to-back airflow and cooling.



CAUTION: If a third-party rack is used, observe the following additional requirements to ensure adequate airflow and to prevent damage to the equipment:

- Front and rear doors—If the 42U rack includes closing front and rear doors, you must allow 5,350 sq cm (830 sq in) of holes evenly distributed from top to bottom to permit adequate airflow (equivalent to the required 64 percent open area for ventilation).
 - Side—The clearance between the installed rack component and the side panels of the rack must be a minimum of 7 cm (2.75 in).
-



IMPORTANT: The HP ProLiant DL385p Gen8 Server cable management arm is not supported on Compaq branded 7000 series racks.

Temperature requirements

To ensure continued safe and reliable equipment operation, install or position the system in a well-ventilated, climate-controlled environment.

The maximum recommended ambient operating temperature (TMRA) for most server products is 35°C (95°F). The temperature in the room where the rack is located must not exceed 35°C (95°F).

-
- ⚠ **CAUTION:** To reduce the risk of damage to the equipment when installing third-party options:
- Do not permit optional equipment to impede airflow around the server or to increase the internal rack temperature beyond the maximum allowable limits.
 - Do not exceed the manufacturer's TMRA.
-

Power requirements

Installation of this equipment must comply with local and regional electrical regulations governing the installation of information technology equipment by licensed electricians. This equipment is designed to operate in installations covered by NFPA 70, 1999 Edition (National Electric Code) and NFPA-75, 1992 (code for Protection of Electronic Computer/Data Processing Equipment). For electrical power ratings on options, refer to the product rating label or the user documentation supplied with that option.

-
- ⚠ **WARNING:** To reduce the risk of personal injury, fire, or damage to the equipment, do not overload the AC supply branch circuit that provides power to the rack. Consult the electrical authority having jurisdiction over wiring and installation requirements of your facility.
-

- ⚠ **CAUTION:** Protect the server from power fluctuations and temporary interruptions with a regulating uninterruptible power supply. This device protects the hardware from damage caused by power surges and voltage spikes and keeps the system in operation during a power failure.
-

When installing more than one server, you may need to use additional power distribution devices to safely provide power to all devices. Observe the following guidelines:





- Balance the server power load between available AC supply branch circuits.
- Do not allow the overall system AC current load to exceed 80 percent of the branch circuit AC current rating.
- Do not use common power outlet strips for this equipment.
- Provide a separate electrical circuit for the server.

Electrical grounding requirements

The server must be grounded properly for proper operation and safety. In the United States, you must install the equipment in accordance with NFPA 70, 1999 Edition (National Electric Code), Article 250, as well as any local and regional building codes. In Canada, you must install the equipment in accordance with Canadian Standards Association, CSA C22.1, Canadian Electrical Code. In all other countries, you must install the equipment in accordance with any regional or national electrical wiring codes, such as the International Electrotechnical Commission (IEC) Code 364, parts 1 through 7. Furthermore, you must be sure that all power distribution devices used in the installation, such as branch wiring and receptacles, are listed or certified grounding-type devices.

Because of the high ground-leakage currents associated with multiple servers connected to the same power source, HP recommends the use of a PDU that is either permanently wired to the building's branch circuit or includes a nondetachable cord that is wired to an industrial-style plug. NEMA locking-style plugs or those complying with IEC 60309 are considered suitable for this purpose. Using common power outlet strips for the server is not recommended.

Connecting a DC power cable to a DC power source

-
-  **WARNING:** To reduce the risk of electric shock or energy hazards:
- This equipment must be installed by trained service personnel, as defined by the NEC and IEC 60950-1, Second Edition, the standard for Safety of Information Technology Equipment.
 - Connect the equipment to a reliably grounded SELV source. An SELV source is a secondary circuit that is designed so normal and single fault conditions do not cause the voltages to exceed a safe level (60 V direct current).
 - The branch circuit overcurrent protection must be rated 24A.
-
-  **WARNING:** When installing a DC power supply, the ground wire must be connected before the positive or negative leads.
-
-  **WARNING:** Remove power from the power supply before performing any installation steps or maintenance on the power supply.
-
-  **CAUTION:** The server equipment connects the earthed conductor of the DC supply circuit to the earthing conductor at the equipment. For more information, see the *HP 750W Common Slot -48V DC Input Hot-Plug Power Supply Kit Installation Instructions*.
-
-  **CAUTION:** If the DC connection exists between the earthed conductor of the DC supply circuit and the earthing conductor at the server equipment, the following conditions must be met:
- This equipment must be connected directly to the DC supply system earthing electrode conductor or to a bonding jumper from an earthing terminal bar or bus to which the DC supply system earthing electrode conductor is connected.
 - This equipment should be located in the same immediate area (such as adjacent cabinets) as any other equipment that has a connection between the earthed conductor of the same DC supply circuit and the earthing conductor, and also the point of earthing of the DC system. The DC system should be earthed elsewhere.
 - The DC supply source is to be located within the same premises as the equipment.
 - Switching or disconnecting devices should not be in the earthed circuit conductor between the DC source and the point of connection of the earthing electrode conductor.
-

To connect a DC power cable to a DC power source:

1. Cut the DC power cord ends no shorter than 150 cm (59.06 in).
2. If the power source requires ring tongues, use a crimping tool to install the ring tongues on the power cord wires.



IMPORTANT: The ring tongues must be UL approved and accommodate 12 gauge wires.



IMPORTANT: The minimum nominal thread diameter of a pillar or stud type terminal must be 3.5 mm (0.138 in); the diameter of a screw type terminal must be 4.0 mm (0.157 in).

3. Stack each same-colored pair of wires and then attach them to the same power source. The power cord consists of three wires (black, red, and green).

For more information, see the *HP 750W Common Slot -48V DC Input Hot-Plug Power Supply Installation Instructions*.

Rack warnings



WARNING: To reduce the risk of personal injury or damage to the equipment, be sure that:

- The leveling jacks are extended to the floor.
 - The full weight of the rack rests on the leveling jacks.
 - The stabilizing feet are attached to the rack if it is a single-rack installation.
 - The racks are coupled together in multiple-rack installations.
 - Only one component is extended at a time. A rack may become unstable if more than one component is extended for any reason.
-



WARNING: To reduce the risk of personal injury or equipment damage when unloading a rack:

- At least two people are needed to safely unload the rack from the pallet. An empty 42U rack can weigh as much as 115 kg (253 lb), can stand more than 2.1 m (7 ft) tall, and might become unstable when being moved on its casters.
 - Never stand in front of the rack when it is rolling down the ramp from the pallet. Always handle the rack from both sides.
-

Identifying the contents of the server shipping carton

Unpack the server shipping carton and locate the materials and documentation necessary for installing the server. All the rack mounting hardware necessary for installing the server into the rack is included with the rack or the server.

The contents of the server shipping carton include:

- Server
- Power cord
- Hardware documentation, Documentation CD, and software products
- Rack-mounting hardware

In addition to the supplied items, you might need:

- Operating system or application software
- Hardware options

Installing hardware options

Install any hardware options before initializing the server. For options installation information, refer to the option documentation. For server-specific information, refer to "Hardware options installation (on page 44)."

Installing the server into the rack



CAUTION: Always plan the rack installation so that the heaviest item is on the bottom of the rack. Install the heaviest item first, and continue to populate the rack from the bottom to the top.

1. Install the server and cable management arm into the rack. For more information, see the installation instructions that ship with the 2U Quick Deploy Rail System.
2. Connect peripheral devices to the server. For information on identifying connectors, see "Rear panel components (on page 13)."



WARNING: To reduce the risk of electric shock, fire, or damage to the equipment, do not plug telephone or telecommunications connectors into RJ-45 connectors.

3. Connect the power cord to the rear of the server.
4. Install the power cord anchors.

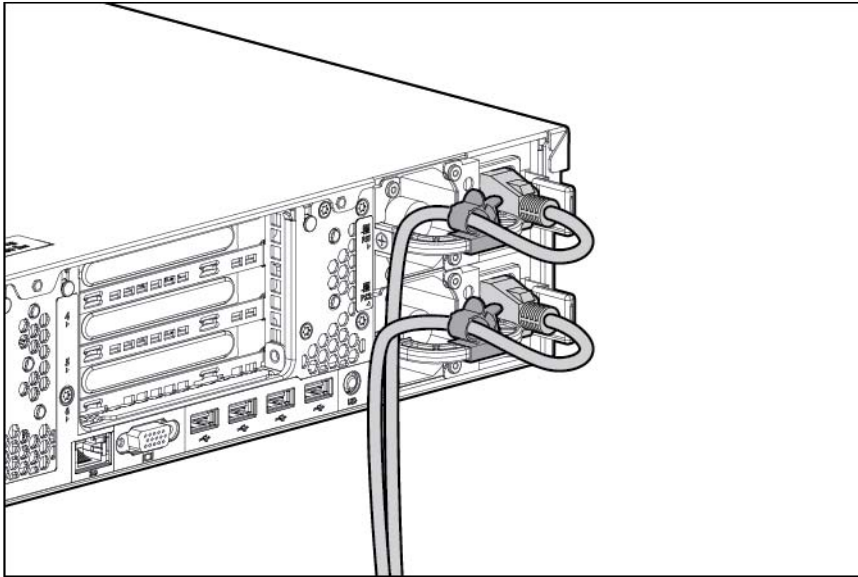

5. Secure the cables to the cable management arm.



IMPORTANT: When using cable management arm components, be sure to leave enough slack in each of the cables to prevent damage to the cables when the server is extended from the rack.

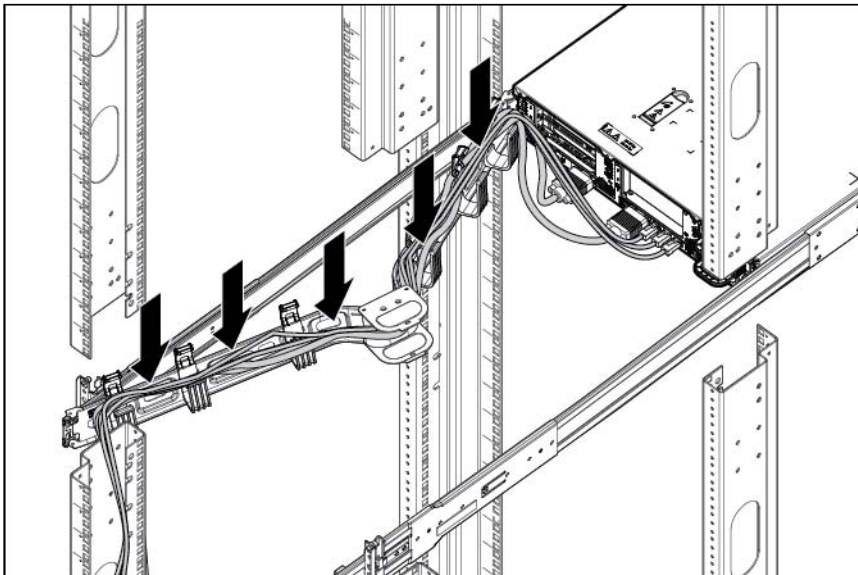

6. Connect the power cord to the AC power source.



WARNING: To reduce the risk of electric shock or damage to the equipment:

- Do not disable the power cord grounding plug. The grounding plug is an important safety feature.
 - Plug the power cord into a grounded (earthed) electrical outlet that is easily accessible at all times.
 - Unplug the power cord from the power supply to disconnect power to the equipment.
 - Do not route the power cord where it can be walked on or pinched by items placed against it. Pay particular attention to the plug, electrical outlet, and the point where the cord extends from the server.
-

Installing the operating system

This HP ProLiant server does not ship with provisioning media. Everything needed to manage and install the system software and firmware is preloaded on the server.

To operate properly, the server must have a supported operating system. For the latest information on operating system support, see the HP website (<http://www.hp.com/go/supportos>).

To install an operating system on the server, use one of the following methods:

- **Intelligent Provisioning**—The iLO Management Engine is a new feature on ProLiant servers that contains Intelligent Provisioning for embedded deployment, updating, and provisioning capabilities. Intelligent Provisioning can configure the server and install an operating system, eliminating the need for SmartStart CDs and Smart Update Firmware DVDs.

To install an operating system on the server with Intelligent Provisioning (local or remote):

- a. Connect the Ethernet cable between the network connector on the server and a network jack.
 - b. Press the Power On/Standby button.
 - c. During server POST, press the **F10** key.
 - d. Complete the initial Preferences and Registration portion of Intelligent Provisioning (on page 100).
 - e. At the 1 Start screen, click the **Configure and Install** button.
 - f. To finish the installation, follow the onscreen prompts. An Internet connection is required to update the firmware and systems software.
- **Remote deployment installation**—To remotely deploy an operating system, use Insight Control server deployment for an automated solution.

For additional system software and firmware updates, download the HP Service Pack for ProLiant from the HP website (<http://www.hp.com/go/spp/download>). Software and firmware must be updated before using the server for the first time, unless any installed software or components require an older version. For more information, see "Keeping the system current (on page 108)."

The Smart Update Firmware DVD ISO is also available at the download tab on the HP website (<http://www.hp.com/go/foundation>).

For more information on using these installation methods, see the HP website (<http://www.hp.com/go/ilo>).

Powering on and selecting boot options

1. Connect the Ethernet cable.
2. Press the Power On/Standby button.

3. During the initial boot:
 - To modify the server configuration ROM default settings, press **F9** when prompted from the start up sequence to enter the RBSU. By default, RBSU runs in the English language.
 - If you do not need to modify the server configuration and are ready to install the system software, press **F10** to access Intelligent Provisioning.

NOTE: If an HP Smart Array controller has been added or is embedded in the system, the controller defaults to a RAID configuration based on the size and number of hard drives installed. For more information on modifying the controller default settings, see the documentation on the Documentation CD.

For more information on automatic configuration, see the *HP ROM-Based Setup Utility User Guide* on the Documentation CD or the iLO Management Engine Information Library (<http://www.hp.com/go/ilomgmtengine/docs>).

Registering the server

To register the server, see the HP Registration website (<http://register.hp.com>).

Hardware options installation

Introduction

If more than one option is being installed, read the installation instructions for all the hardware options and identify similar steps to streamline the installation process.

-
-  **WARNING:** To reduce the risk of personal injury from hot surfaces, allow the drives and the internal system components to cool before touching them.

 -  **CAUTION:** To prevent damage to electrical components, properly ground the server before beginning any installation procedure. Improper grounding can cause electrostatic discharge.

Processor option

The server supports single- and dual-processor operation.

-
-  **CAUTION:** To avoid damage to the processor and system board, only authorized personnel should attempt to replace or install the processor in this server.

 -  **CAUTION:** To help avoid damage to the processor and system board, do not install the processor without using the processor installation tool.

 -  **CAUTION:** To prevent possible server malfunction and damage, dual processor configurations must contain processors with the same part number.

 -  **IMPORTANT:** Processor socket 1 must be populated at all times or the server does not function properly.

To install the component:

1. Update the system ROM.
Locate and download the latest ROM version from the HP website (<http://www.hp.com/support>). Follow the instructions on the website to update the system ROM.
2. Power down the server (on page 23).
3. Remove all power:
 - a. Disconnect each power cord from the power source.
 - b. Disconnect each power cord from the server.
4. Extend the server from the rack (on page 23).
5. Remove the access panel (on page 25).

6. If a full-length expansion board is installed in the primary PCIe riser cage, release the full-length expansion board retainer, and then remove the PCIe riser cage.

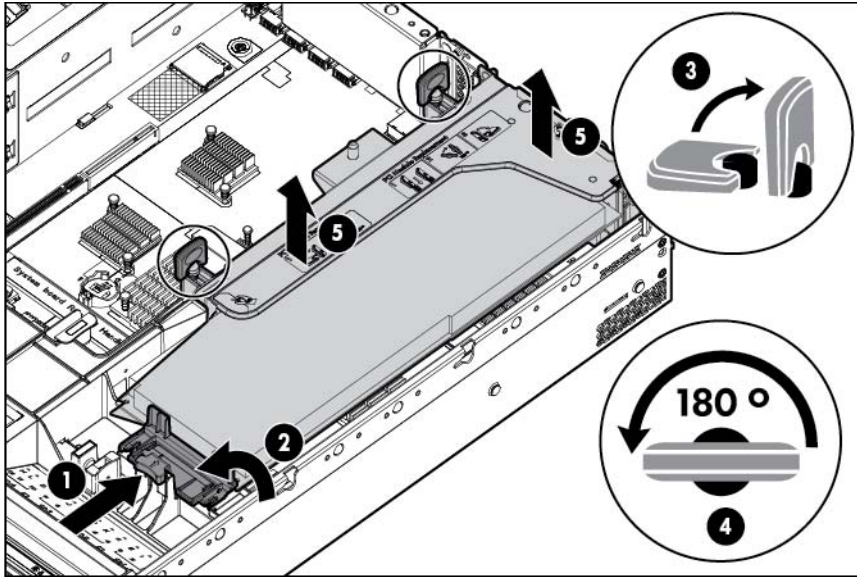

7. If a full-length expansion board is installed in the secondary PCIe riser cage, release the full-length expansion board retainer, and then remove the PCIe riser cage.

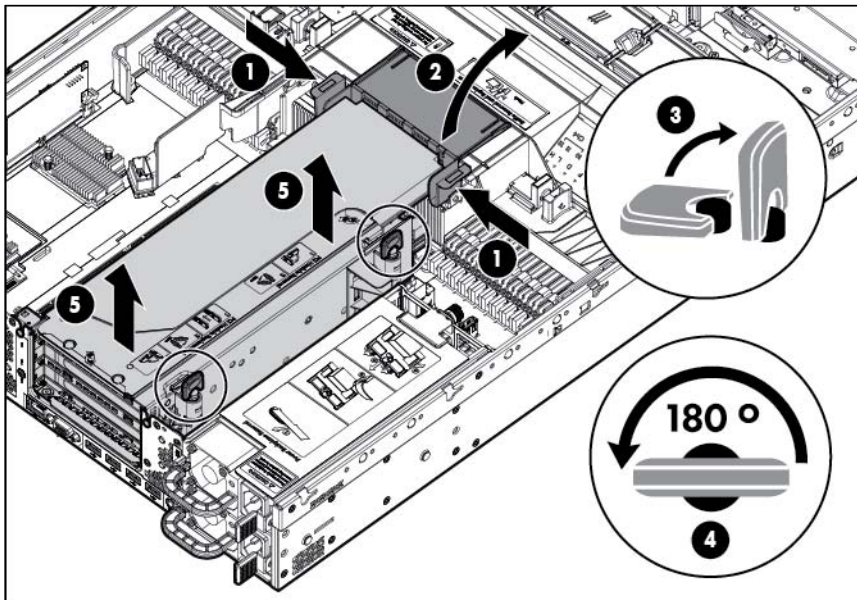

8. Remove the air baffle (on page 34).

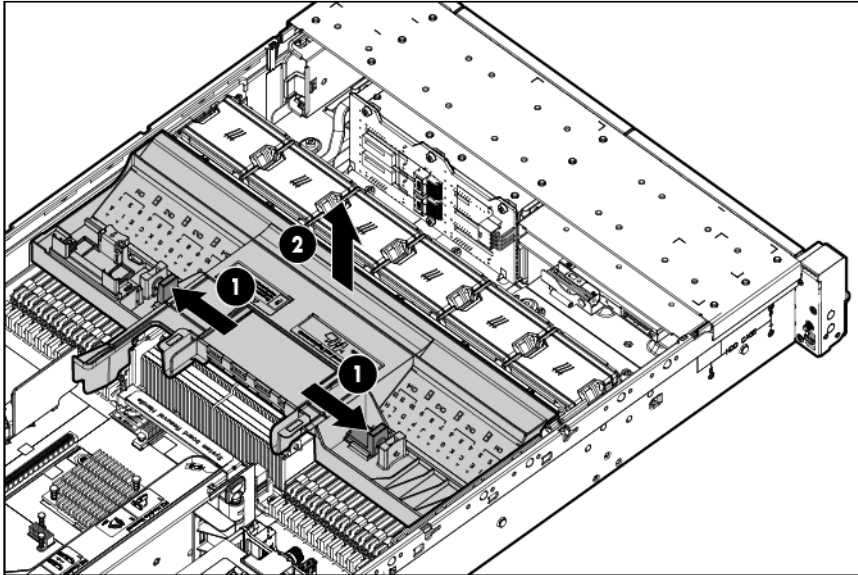

9. Open the heatsink retaining bracket, and then remove the heatsink blank.

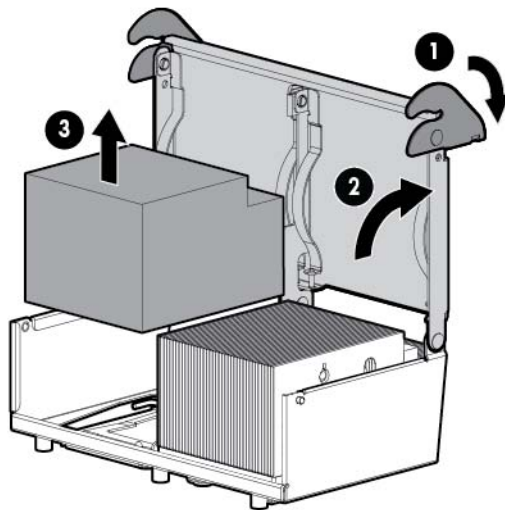

10. Open the processor socket locking lever and the retaining bracket, and then remove the processor socket protective cover.

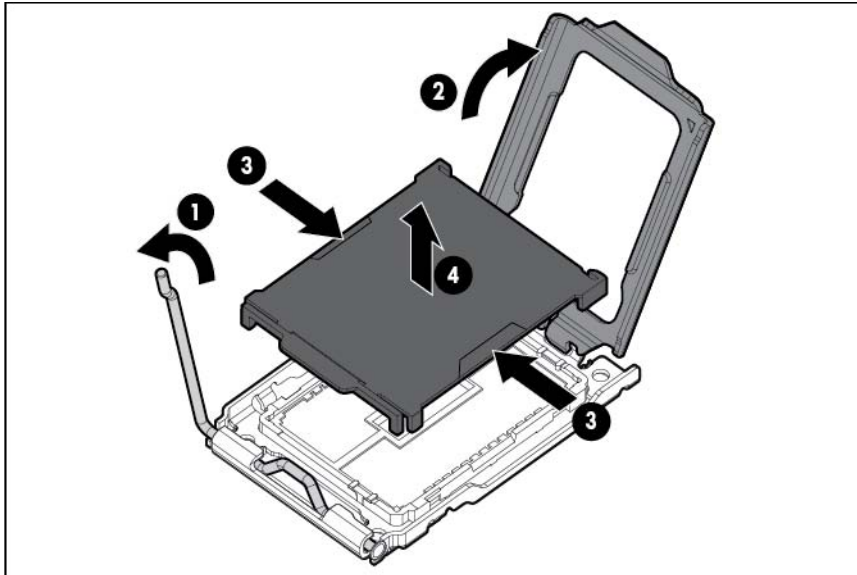

IMPORTANT: Be sure the processor remains inside the processor installation tool.

11. If the processor has separated from the installation tool, carefully re-insert the processor in the tool. Handle the processor by the edges only, and do not touch the bottom of the processor, especially the contact area.

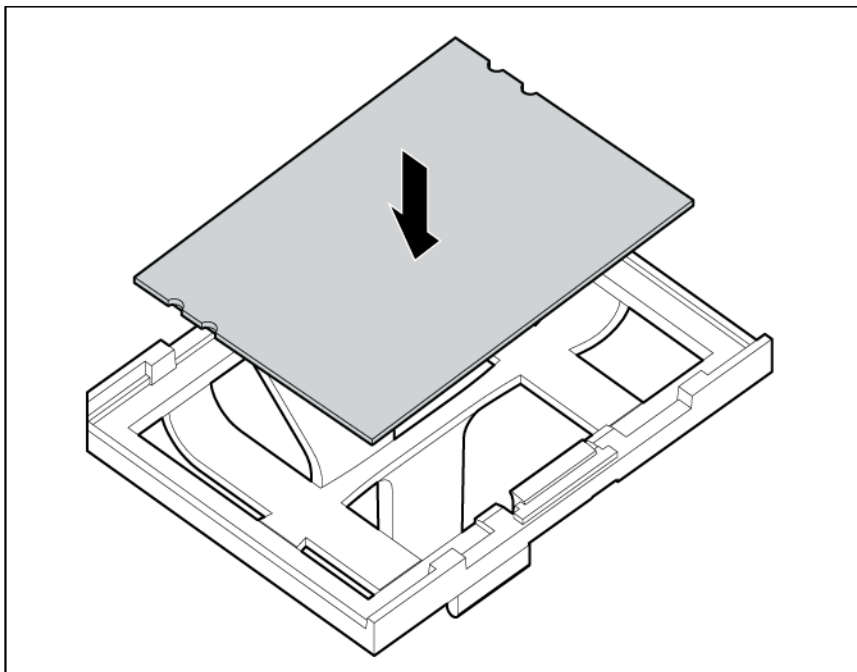

12. The processor fits one way into the socket. Use the alignment guides on the processor and socket to properly align the processor with the socket. Install the spare processor. **THE PINS ON THE SYSTEM BOARD ARE VERY FRAGILE AND EASILY DAMAGED.**

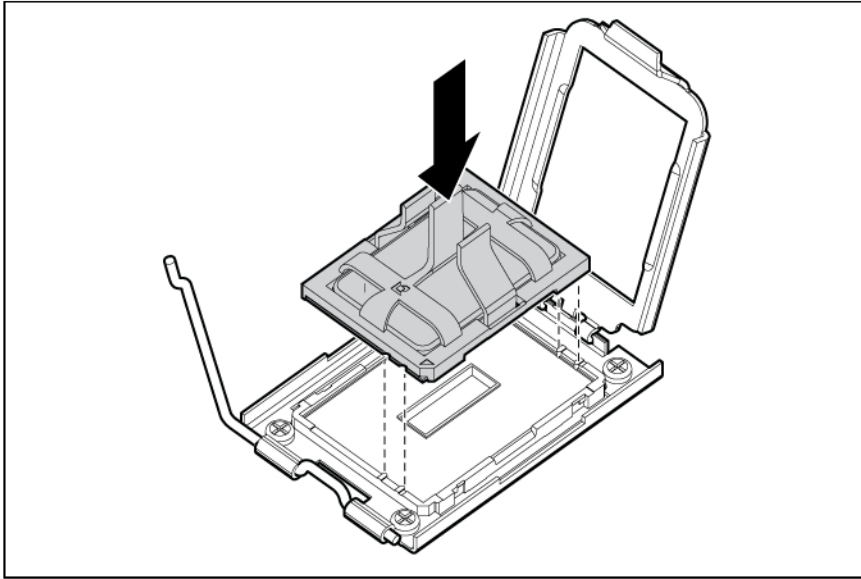

CAUTION: THE PINS ON THE SYSTEM BOARD ARE VERY FRAGILE AND EASILY DAMAGED. To avoid damage to the system board:

- Never install or remove a processor without using the processor installation tool.
- Do not touch the processor socket contacts.
- Do not tilt or slide the processor when lowering the processor into the socket.

13. Press the tabs on the processor tool to release the processor, and then remove the processor tool.

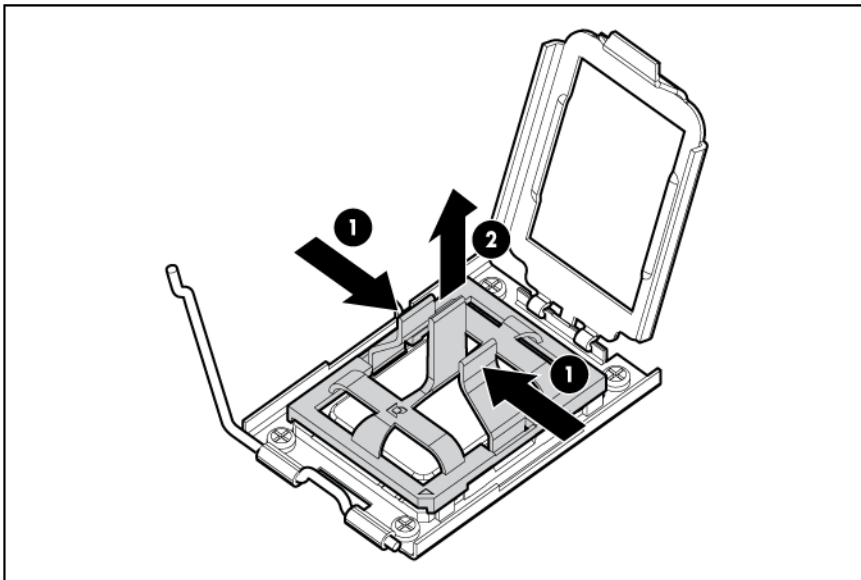

14. Close the processor socket retaining bracket and the processor locking lever.



CAUTION: Be sure to close the processor socket retaining bracket before closing the processor locking lever. The lever should close without resistance. Forcing the lever closed can damage the processor and socket, requiring system board replacement.

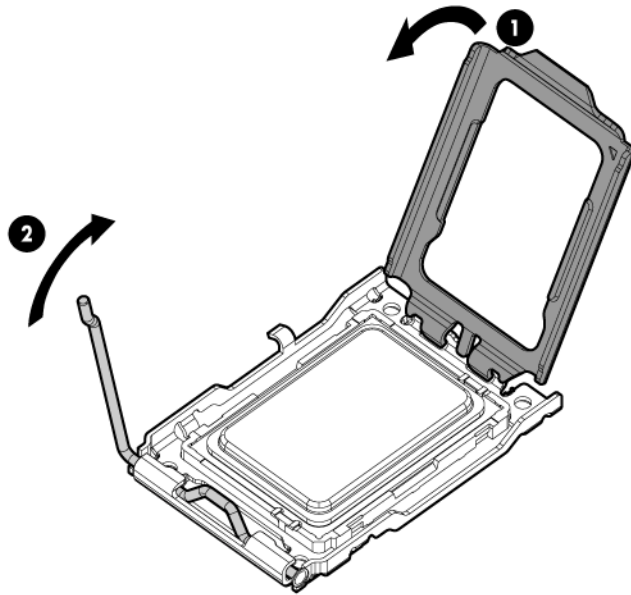

15. Remove the heatsink cover.

CAUTION: After the cover is removed, do not touch the thermal interface media.

16. Install the heatsink, and close the heatsink retaining bracket.
Be sure to align the pins on the heatsink with the pins on the processor cage.

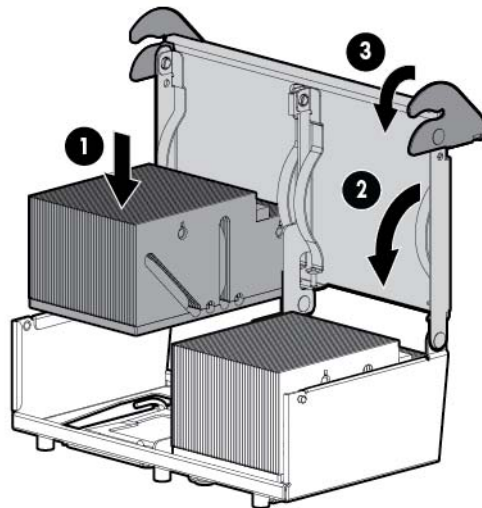

17. Remove the fan blanks from bays 1 and 2.

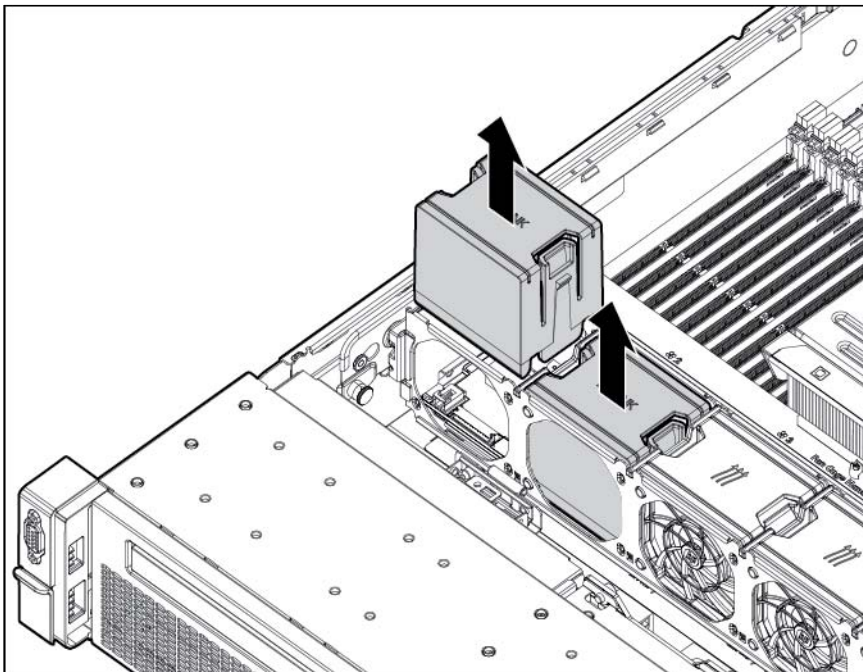

18. Install the fans into bays 1 and 2.

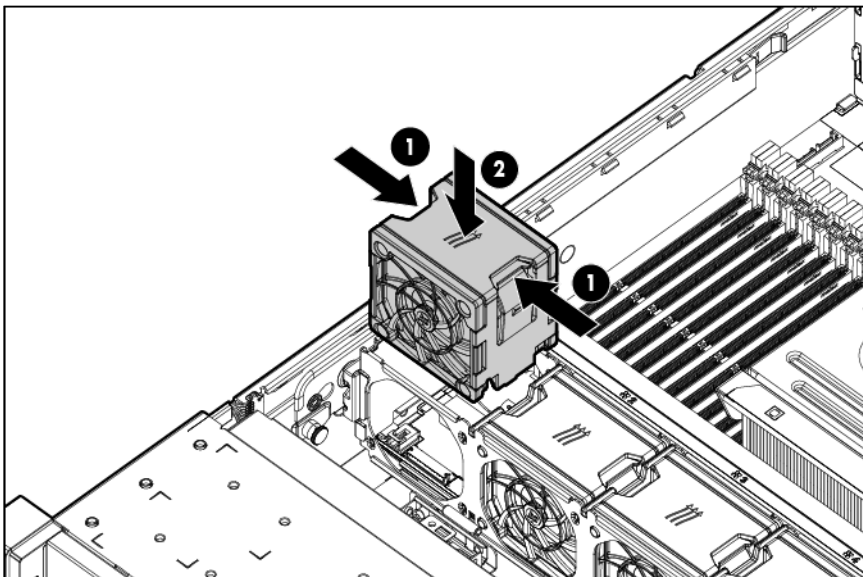

19. Install the air baffle.

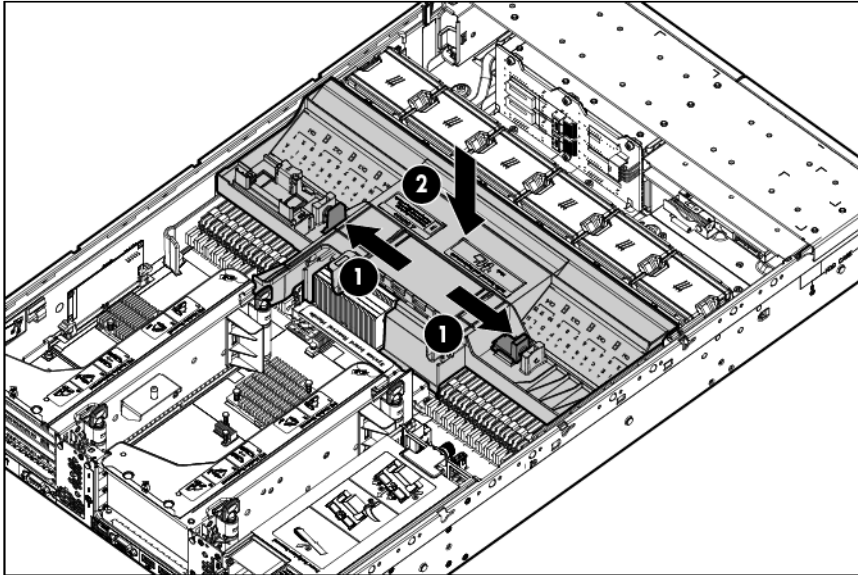

20. Install the primary PCIe riser cage.

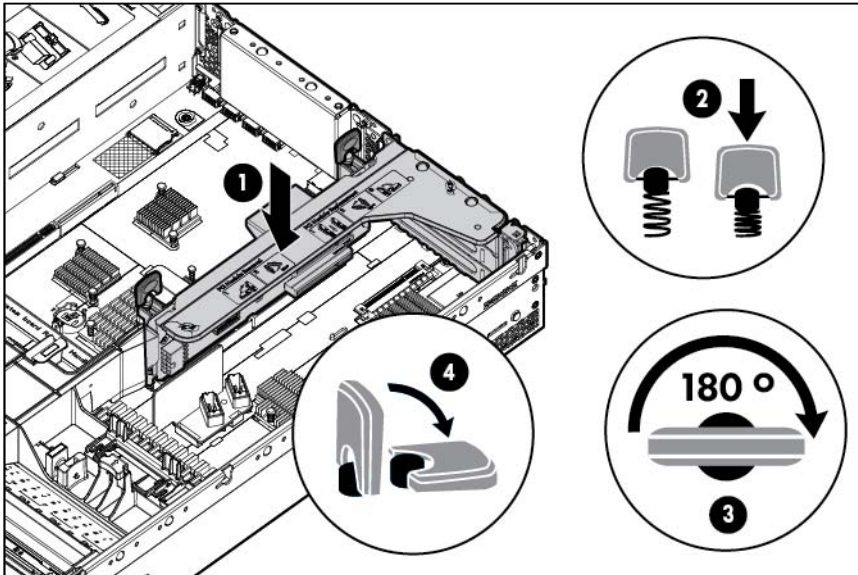

21. Install the secondary PCIe riser cage.

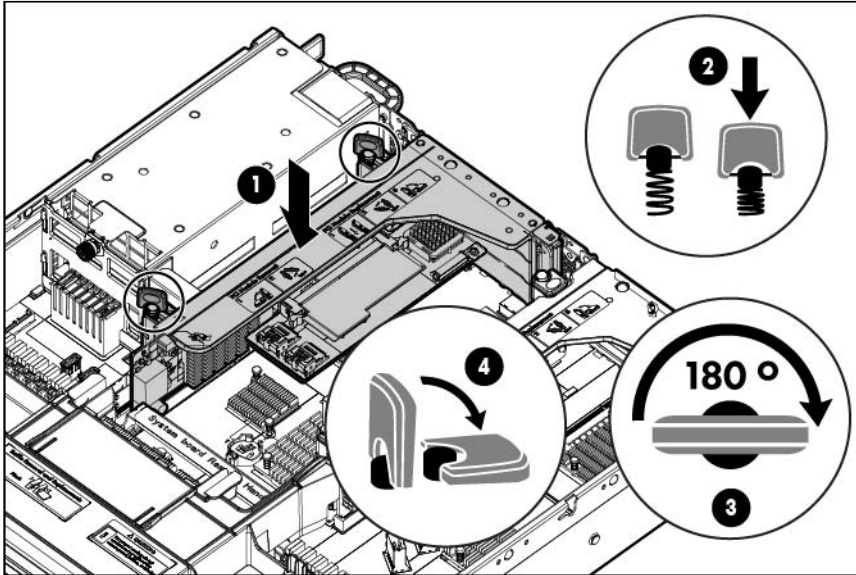

22. If necessary, secure the full-length expansion board retainer for the primary or the secondary PCIe riser cages on the air baffle.

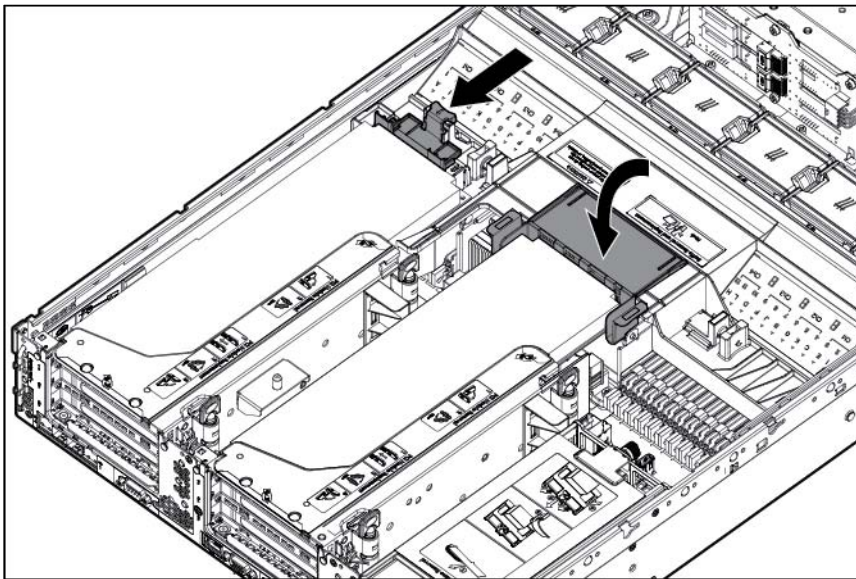

23. Install the access panel (on page 25).
24. Install the server into the rack.
25. Connect each power cord to the server.
26. Connect each power cord to the power source.
27. Power up the server (on page 23).

Memory options



IMPORTANT: This server does not support mixing LRDIMMs or RDIMMs. Attempting to mix any combination of these DIMMs can cause the server to halt during BIOS initialization.

The memory subsystem in this server can support LRDIMMs or RDIMMs:

- RDIMMs offer lower latency in one DIMM per channel configurations and (relatively) low power consumption. They include address parity protection.
- LRDIMMs support higher densities than single- and dual-rank RDIMMs, and higher speeds than quad-rank RDIMMs. This support enables you to install more high capacity DIMMs, resulting in higher system capacities and higher bandwidth.

All types are referred to as DIMMs when the information applies to all types. When specified as LRDIMM or RDIMM, the information applies to that type only. All memory installed in the server must be the same type.

The server supports the following DIMM speeds:

- Single- and dual-rank PC3-10600 (DDR-1333) RDIMMs operating at up to 1333 MT/s
- Single- and dual-rank PC3-12800 (DDR-1600) RDIMMs operating at up to 1600 MT/s
- Quad-rank PC3L-10600 (DDR3-1333) LRDIMMs, operating as dual-rank DIMMs, at up to 1333 MT/s

Speed, voltage, and capacity

DIMM type	DIMM capacity	DIMM rank	Native speed (MT/s)	Voltage
RDIMM	4 GB	Single-rank	1600	STD 1.5 V
RDIMM	4 GB	Single-rank	1333	LV 1.35 V
RDIMM	4 GB	Single-rank	1333	ULV 1.25 V
RDIMM	8 GB	Single-rank	1600	STD 1.5 V
RDIMM	8 GB	Dual-rank	1333	LV 1.35 V
RDIMM	8 GB	Dual-rank	1333	ULV 1.25 V
RDIMM	16 GB	Dual-rank	1600	STD 1.5 V
RDIMM	16 GB	Dual-rank	1333	LV 1.35 V
LRDIMM	32 GB	Quad-rank	1333	LV 1.35 V

Depending on the processor model, the number of DIMMs installed, and the voltage(s) of the DIMMs installed, the memory clock speed can be reduced from the DIMMs' native speed. See the following tables for details.

Populated DIMM speed (MT/s), RDIMM

Memory modules per channel	Single-rank or Dual-rank	Memory module native speed	Memory bus speed (standard voltage memory module)	Memory bus speed (low voltage memory module)	Memory bus speed (ultra low voltage memory module)
1	1	1600 MHz	1600 MHz	1333 MHz	1333 MHz
1	1	1333 MHz	1333 MHz	1333 MHz	1333 MHz
2	2 Single-rank	1600 MHz 1333 MHz	1333 MHz	1333 MHz	1333 MHz
2	2 Dual-rank	1600 MHz 1333 MHz	1333 MHz	1333 MHz	1066 MHz
2	2 mixed	1600 MHz 1333 MHz	1333MHz	1333 MHz	1066 MHz
3	3 Single-rank	1600 MHz 1333 MHz	1066 MHz	1066 MHz	800 MHz
3	3 Dual-rank	1600 MHz 1333 MHz	1066 MHz	800 MHz	667 MHz

Memory modules per channel	Single-rank or Dual-rank	Memory module native speed	Memory bus speed (standard voltage memory module)	Memory bus speed (low voltage memory module)	Memory bus speed (ultra low voltage memory module)
3	3 mixed	1600 MHz 1333 MHz	1066 MHz	800 MHz	667 MHz

Populated DIMM speed (MT/s), LRDIMM

Memory modules per channel	Number of LRDIMMs	Memory module native speed	Memory bus speed (standard voltage memory module)	Memory bus speed (low voltage memory module)	Memory bus speed (ultra low voltage memory module)
1	1	1333 MHz	—	1333 MHz	1333 MHz
2	2	1333 MHz	—	1333 MHz	1066 MHz
3	3	1333 MHz	—	800 MHz	667 MHz

If RDIMMs of different native voltages are installed together, you can change the DIMM voltage through the **DIMM Voltage Preference** menu (under the **Advanced Power Management Options** menu) in RSBU ("Using RSBU" on page 104). **Optimized for Performance** is the default setting, but choosing **Optimized for Power** reduces the voltage, which may also reduce the DIMM frequency.

Populated RDIMM voltage

1.25V	1.35V	1.5V	RBSU setting	Output voltage
x	x		Performance	1.35V
x	x		Power	1.25V
	x	x	Performance	1.5V
	x	x	Power	1.35V
x		x	N/A	Not allowed. System halts during POST.
x	x	x	N/A	Not allowed. System halts during POST.

HP SmartMemory

HP SmartMemory, introduced for Gen8 servers, authenticates HP Qualified memory and verifies whether installed memory has passed HP qualification and test processes.

Memory subsystem architecture

The memory subsystem in this server is divided into channels. Each processor supports four channels, and each channel supports three DIMM slots, as illustrated.

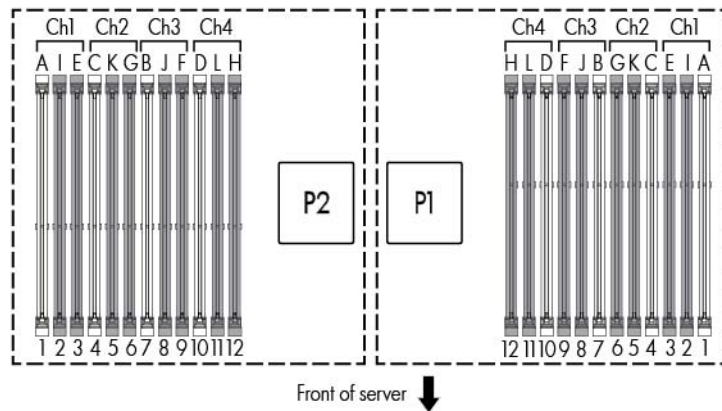

This multi-channel architecture provides enhanced performance in Advanced ECC mode. This architecture also enables Online Spare Memory modes.

DIMM slots in this server are identified by number and by letter:

- Letters identify the population order.
- Slot numbers indicate the DIMM slot ID for spare replacement.

Population order

For memory configurations with a single processor or multiple processors, populate the DIMM slots in the following order:

- LRDIMM: Sequentially in alphabetical order (A through L)
- RDIMM: Sequentially in alphabetical order (A through L)

After installing the DIMMs, use RBSU to configure Advanced ECC, or online spare memory support.

Single-, dual-, and quad-rank DIMMs

To understand and configure memory protection modes properly, an understanding of single-, dual-, and quad-rank DIMMs is helpful. Some DIMM configuration requirements are based on these classifications.

A single-rank DIMM has one set of memory chips that is accessed while writing to or reading from the memory. A dual-rank DIMM is similar to having two single-rank DIMMs on the same module, with only one rank accessible at a time. A quad-rank DIMM is, effectively, two dual-rank DIMMs on the same module. Only one rank is accessible at a time. The server memory control subsystem selects the proper rank within the DIMM when writing to or reading from the DIMM.

Dual- and quad-rank DIMMs provide the greatest capacity with the existing memory technology. For example, if current DRAM technology supports 8-GB single-rank DIMMs, a dual-rank DIMM would be 16 GB, and a quad-rank DIMM would be 32 GB.

LRDIMMs are labeled as quad-rank DIMMs; however, they function more like dual-rank DIMMs. There are four ranks of DRAM on the DIMM, but the LRDIMM buffer creates an abstraction that allows the DIMM to

appear as a dual-rank DIMM to the system. The LRDIMM buffer also isolates the electrical loading of the DRAM from the system to allow for faster operation. These two changes allow the system to support up to three LRDIMMs per memory channel, providing for up to 50% greater memory capacity and higher memory operating speed compared to quad-rank RDIMMs.

DIMM identification

To determine DIMM characteristics, use the label attached to the DIMM and the following illustration and table.

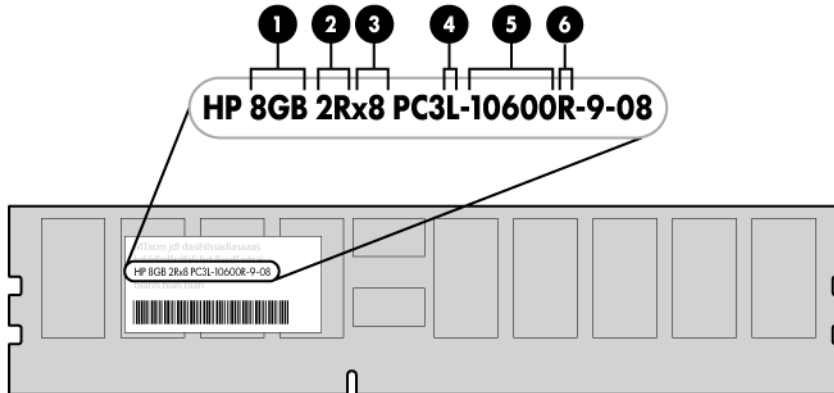

Item	Description	Definition
1	Size	—
2	Rank	1R = Single-rank 2R = Dual-rank 3R = Three-rank 4R = Quad-rank
3	Data width	x4 = 4-bit x8 = 8-bit
4	Voltage rating	L = Low voltage (1.35V) U = Ultra low voltage (1.25V) Blank or omitted = Standard
5	Memory speed	12800 = 1600-MT/s 10600 = 1333-MT/s 8500 = 1066-MT/s
6	DIMM type	R = RDIMM (registered) E = UDIMM (unbuffered with ECC) L = LRDIMM (load reduced)

For the latest supported memory information, see the QuickSpecs on the HP website (<http://h18000.www1.hp.com/products/quickspecs/ProductBulletin.html>). At the website, choose the geographic region, and then locate the product by name or product category.

Memory configurations

To optimize server availability, the server supports the following AMP modes:

- Advanced ECC—provides up to 4-bit error correction. This mode is the default option for this server.
- Online spare memory—provides protection against failing or degraded DIMMs. Certain memory is reserved as spare, and automatic failover to spare memory occurs when the system detects a DIMM that is degrading. This allows DIMMs that have a higher probability of receiving an uncorrectable memory error (which would result in system downtime) to be removed from operation.

Advanced Memory Protection options are configured in RBSU. If the requested AMP mode is not supported by the installed DIMM configuration, the server boots in Advanced ECC mode. For more information, see "HP ROM-Based Setup Utility (on page 103)."

Maximum capacity

DIMM type	DIMM rank	One processor	Two processors
RDIMM	Single-rank	96 GB	192 GB
RDIMM	Dual-rank	192 GB	384 GB
LRDIMM	Quad-rank	384 GB	768 GB

For the latest memory configuration information, see the QuickSpecs on the HP website (<http://www.hp.com>).

Advanced ECC memory configuration

Advanced ECC memory is the default memory protection mode for this server. Standard ECC can correct single-bit memory errors and detect multi-bit memory errors. When multi-bit errors are detected using Standard ECC, the error is signaled to the server and causes the server to halt.

Advanced ECC protects the server against some multi-bit memory errors. Advanced ECC can correct both single-bit memory errors and 4-bit memory errors if all failed bits are on the same DRAM device on the DIMM.

Advanced ECC provides additional protection over Standard ECC because it is possible to correct certain memory errors that would otherwise be uncorrected and result in a server failure. Using HP Advanced Memory Error Detection technology, the server provides notification when a DIMM is degrading and has a higher probability of uncorrectable memory error.

Online Spare memory configuration

Online spare memory provides protection against degraded DIMMs by reducing the likelihood of uncorrected memory errors. This protection is available without any operating system support.

Online spare memory protection dedicates one rank of each memory channel for use as spare memory. The remaining ranks are available for OS and application use. If correctable memory errors occur at a rate higher than a specific threshold on any of the non-spare ranks, the server automatically copies the memory contents of the degraded rank to the online spare rank. The server then deactivates the failing rank and automatically switches over to the online spare rank.

General DIMM slot population guidelines

Observe the following guidelines for all AMP modes:

- Install DIMMs only if the corresponding processor is installed.

- When two processors are installed, balance the DIMMs across the two processors.
- White DIMM slots denote the first slot of a channel (Ch 1-A, Ch 2-B, Ch 3-C, Ch 4-D).
- Do not mix LRDIMMs or RDIMMs.
- When two processors are installed, install the DIMMs in sequential alphabetical order balanced between the two processors: P1-A, P2-A, P1-B, P2-B, P1-C, P2-C, and so on.

For detailed memory configuration rules and guidelines, use the Online DDR3 Memory Configuration Tool on the HP website (<http://www.hp.com/go/ddr3memory-configurator>).

Advanced ECC population guidelines

For Advanced ECC mode configurations, observe the following guidelines:

- Observe the general DIMM slot population guidelines.
- DIMMs may be installed individually.

Online spare population

For Online Spare memory mode configurations, observe the following guidelines:

- Observe the general DIMM slot population guidelines.
- Each channel must have a valid online spare configuration.
- Each channel can have a different valid online spare configuration.
- Each populated channel must have a spare rank:
 - A single dual-rank DIMM is not a valid configuration.
 - LRDIMMs are treated as dual-rank DIMMs.

Installing a DIMM

The server supports up to 24 DIMMs. To install a DIMM:

1. Power down the server (on page 23).
2. Remove all power:
 - a. Disconnect each power cord from the power source.
 - b. Disconnect each power cord from the server.
3. Extend the server from the rack (on page 23).
4. Remove the access panel (on page 25).
5. Remove the air baffle (on page 34).
6. Open the DIMM slot latches..

7. Install the DIMM.

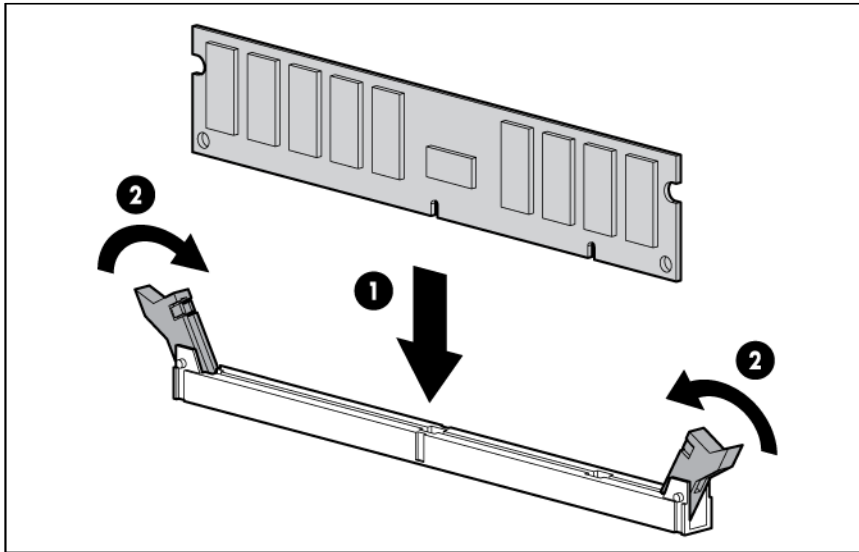

8. Install the access panel (on page 25).
9. Install the server into the rack ("[Installing the server into the rack](#)" on page 40).
10. Connect each power cord to the server.
11. Connect each power cord to the power source.
12. Power up the server (on page 23).

Use RBSU ("[HP ROM-Based Setup Utility](#)" on page 103) to configure the memory mode.

For more information about LEDs and troubleshooting failed DIMMs, see "[Systems Insight Display LED combinations](#) (on page 12)."

Hot-plug hard drive options

When adding hard drives to the server, observe the following general guidelines:

- The system automatically sets all device numbers.
- If only one hard drive is used, install it in the bay with the lowest device number.
- Drives should be the same capacity to provide the greatest storage space efficiency when drives are grouped together into the same drive array.

Installing a hot-plug SAS or SATA hard drive

The server can support 8 SAS or SATA hard drives in a SFF or LFF configuration, or the following configurations with the optional hard drive cage ("[Hard drive cage option](#)" on page 76):

- 12 LFF
- 16 SFF
- 25 SFF

To install the component:

1. Remove the drive blank.

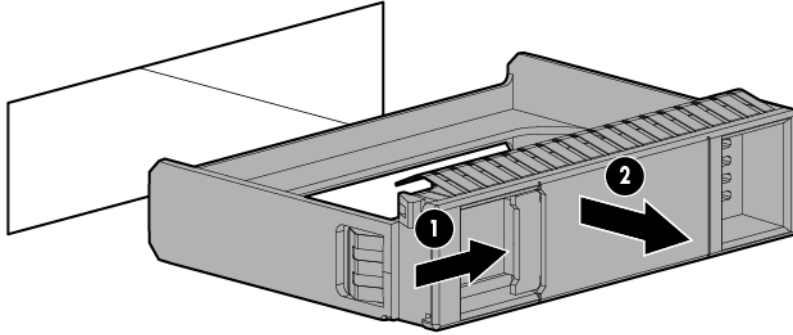

2. Prepare the drive.

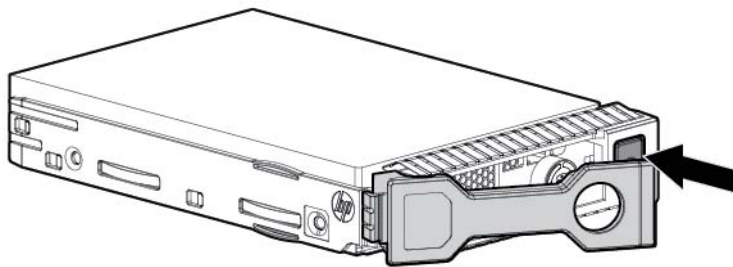

3. Install the drive.

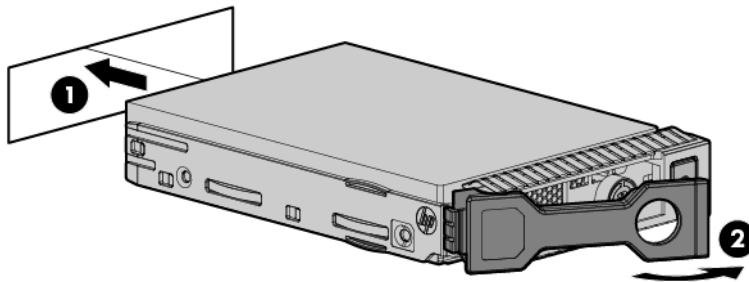

4. Determine the status of the drive from the drive LED definitions (on page 19).

Removing a hot-plug SAS or SATA hard drive

CAUTION: For proper cooling, do not operate the server without the access panel, baffles, expansion slot covers, or blanks installed. If the server supports hot-plug components, minimize the amount of time the access panel is open.

1. Determine the status of the drive from the hot-plug SAS hard drive LED combinations ("Drive LED definitions" on page 19).
2. Back up all server data on the drive.

3. Remove the drive.

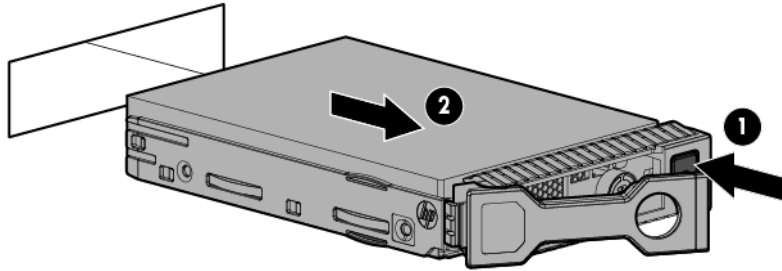

Controller options

The server ships with an embedded Smart Array P420i controller. For more information about the controller and its features, see the *HP Smart Array Controllers for HP ProLiant Servers User Guide* on the HP website (http://www.hp.com/support/SAC_UG_ProLiantServers_en). To configure arrays, see the *Configuring Arrays on HP Smart Array Controllers Reference Guide* on the HP website (http://www.hp.com/support/CASAC_RG_en).

Upgrade options exist for the integrated array controller. For a list of supported options, see the QuickSpecs on the HP website (<http://www.hp.com/support>).

The server supports FBWC. FBWC consists of a cache module and a capacitor pack. The DDR cache module buffers and stores data being written by the controller. When the system is powered on, the capacitor pack charges fully in about 5 minutes. In the event of a system power failure, a fully charged capacitor pack provides power for up to 80 seconds. During that interval, the controller transfers the cached data from DDR memory to flash memory, where the data remains indefinitely or until a controller retrieves the data.

- CAUTION:** The cache module connector does not use the industry-standard DDR3 mini-DIMM pinout. Do not use the controller with cache modules designed for other controller models, because the controller can malfunction and you can lose data. Also, do not transfer this cache module to an unsupported controller model, because you can lose data.
- CAUTION:** To prevent a server malfunction or damage to the equipment, do not add or remove the battery pack while an array capacity expansion, RAID level migration, or stripe size migration is in progress.
- CAUTION:** After the server is powered down, wait 15 seconds and then check the amber LED before unplugging the cable from the cache module. If the amber LED blinks after 15 seconds, do not remove the cable from the cache module. The cache module is backing up data, and data is lost if the cable is detached.
- IMPORTANT:** The battery pack might have a low charge when installed. In this case, a POST error message is displayed when the server is powered up, indicating that the battery pack is temporarily disabled. No action is necessary on your part. The internal circuitry automatically recharges the batteries and enables the battery pack. This process might take up to four hours. During this time, the cache module functions properly, but without the performance advantage of the battery pack.

NOTE: The data protection and the time limit also apply if a power outage occurs. When power is restored to the system, an initialization process writes the preserved data to the hard drives.

Installing the flash-backed write cache module

△ **CAUTION:** The cache module connector does not use the industry-standard DDR3 mini-DIMM pinout. Do not use the controller with cache modules designed for other controller models, because the controller can malfunction and you can lose data. Also, do not transfer this cache module to an unsupported controller model, because you can lose data.

To install the component:

1. Back up all data.
2. Close all applications.

△ **CAUTION:** In systems that use external data storage, be sure that the server is the first unit to be powered down and the last to be powered back up. Taking this precaution ensures that the system does not erroneously mark the drives as failed when the server is powered up.

3. Power down the server (on page 23).
4. Remove all power:
 - a. Disconnect each power cord from the power source.
 - b. Disconnect each power cord from the server.
5. Extend the server from the rack (on page 23).
6. Remove the access panel (on page 25).
7. Install the cache module.

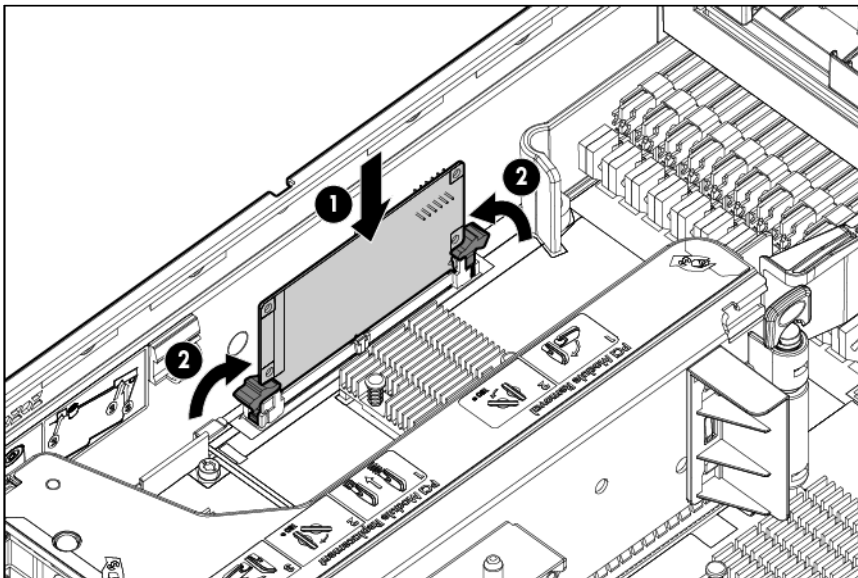

8. Connect the capacitor pack cable to the connector on the top of the cache module.

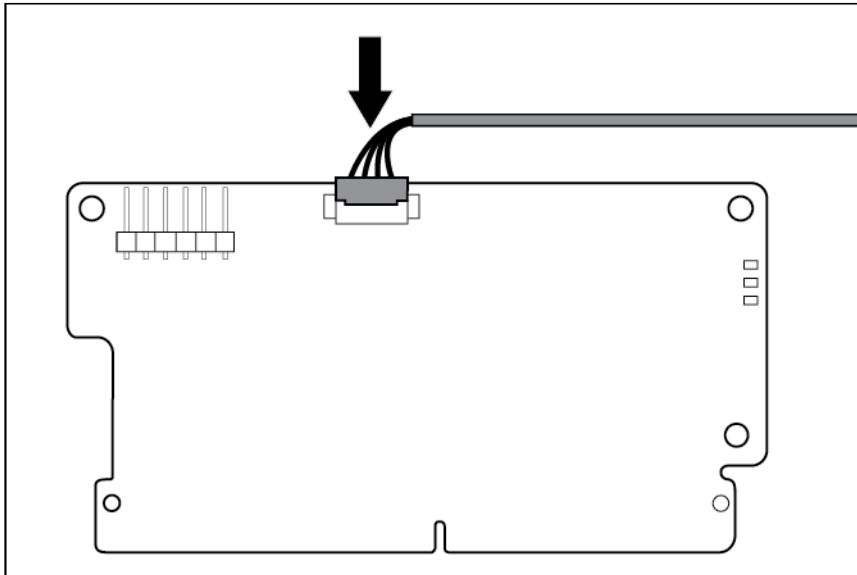

9. Install the access panel (on page 25).
10. Install the server into the rack ("Installing the server into the rack" on page 40).
11. Connect each power cord to the server.
12. Connect each power cord to the power source.
13. Power up the server (on page 23).

Installing the FBWC capacitor pack

- CAUTION:** The cache module connector does not use the industry-standard DDR3 mini-DIMM pinout. Do not use the controller with cache modules designed for other controller models, because the controller can malfunction and you can lose data. Also, do not transfer this cache module to an unsupported controller model, because you can lose data.

To install the component:

1. Back up all data.
2. Close all applications.

- CAUTION:** In systems that use external data storage, be sure that the server is the first unit to be powered down and the last to be powered back up. Taking this precaution ensures that the system does not erroneously mark the drives as failed when the server is powered up.

3. Power down the server (on page 23).
4. Remove all power:
 - a. Disconnect each power cord from the power source.
 - b. Disconnect each power cord from the server.
5. Extend the server from the rack (on page 23).
6. Remove the access panel (on page 25).
7. Install the FBWC module ("Installing the flash-backed write cache module" on page 62), if it is not already installed.

8. Connect the capacitor pack cable to the connector on the top of the cache module.

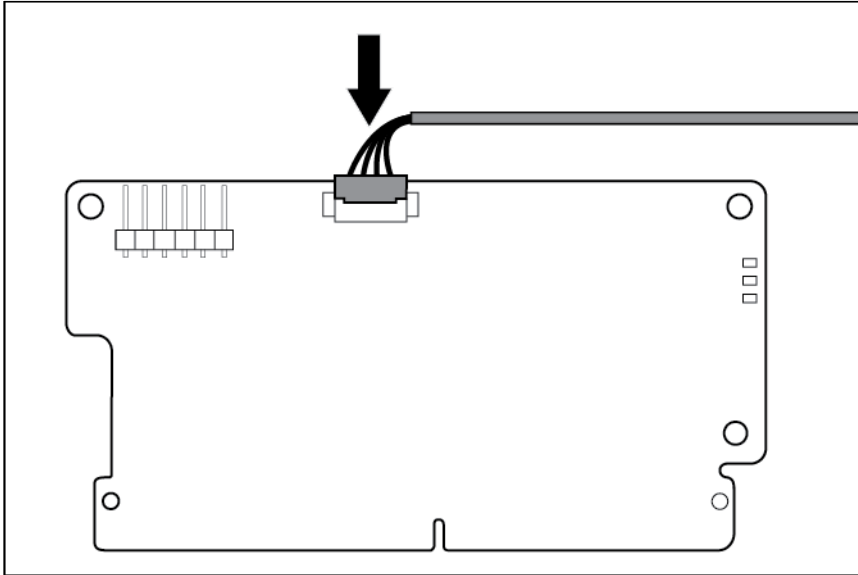

9. Install one or two FBWC capacitor packs into the FBWC capacitor pack holder.

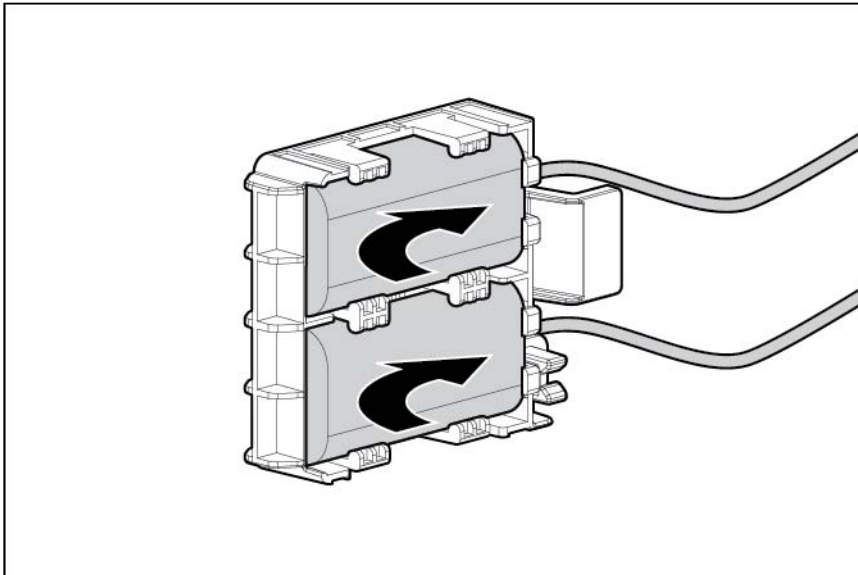

10. Install the FBWC capacitor pack holder into the server:

- 8 or 16 drive SFF

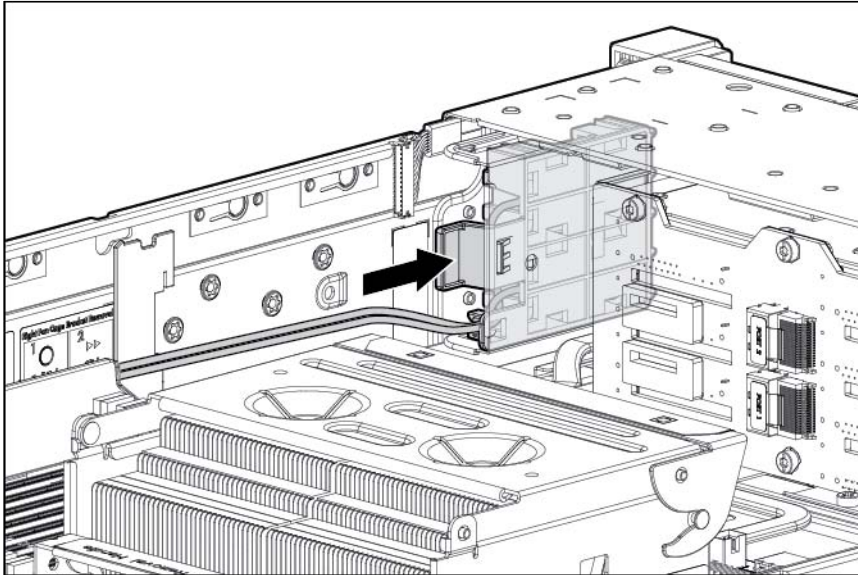

- 8 drive LFF

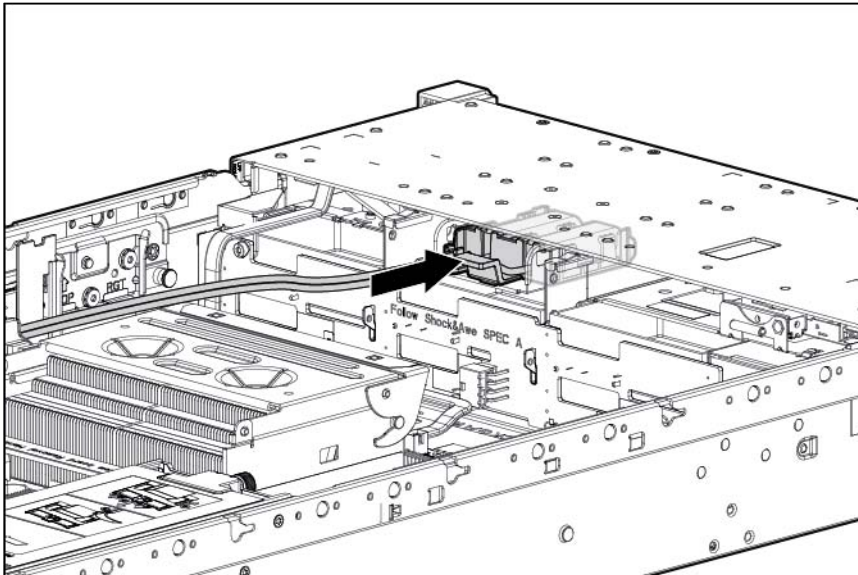

- 12 drive LFF

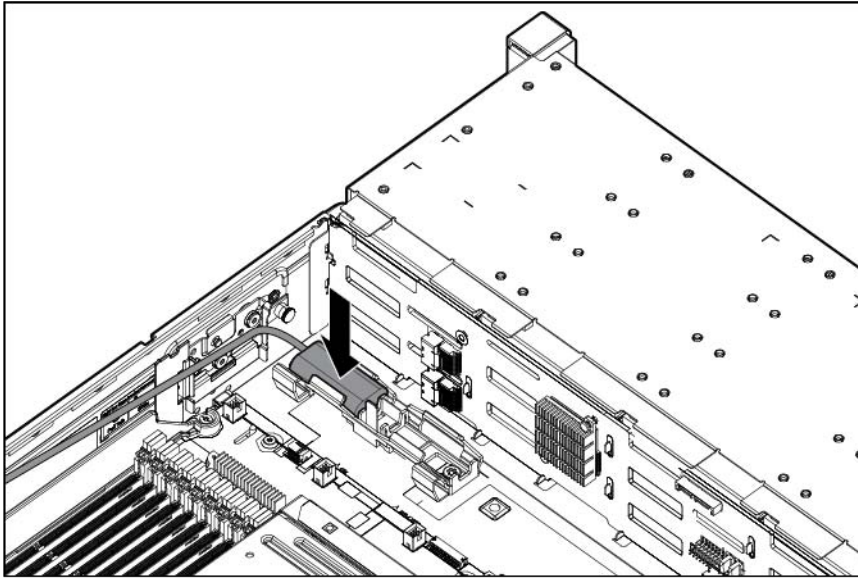

- 25 drive SFF

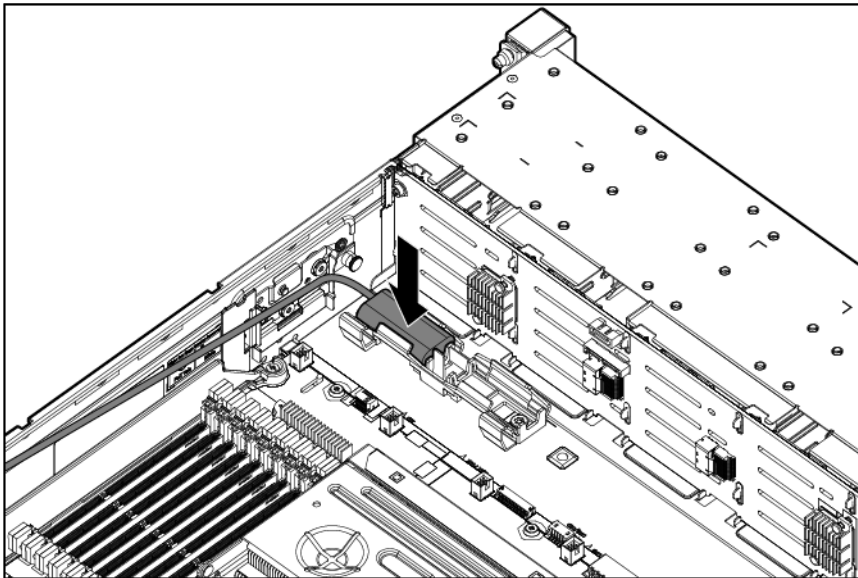

1. Install the access panel (on page 25).
2. Install the server into the rack ("Installing the server into the rack" on page 40).
3. Connect each power cord to the server.
4. Connect each power cord to the power source.
5. Power up the server (on page 23).

Optical drive option

1. Power down the server (on page 23).
2. Remove all power:
 - a. Disconnect each power cord from the power source.

7. Connect the power and data cable to the system board and the optical drive.

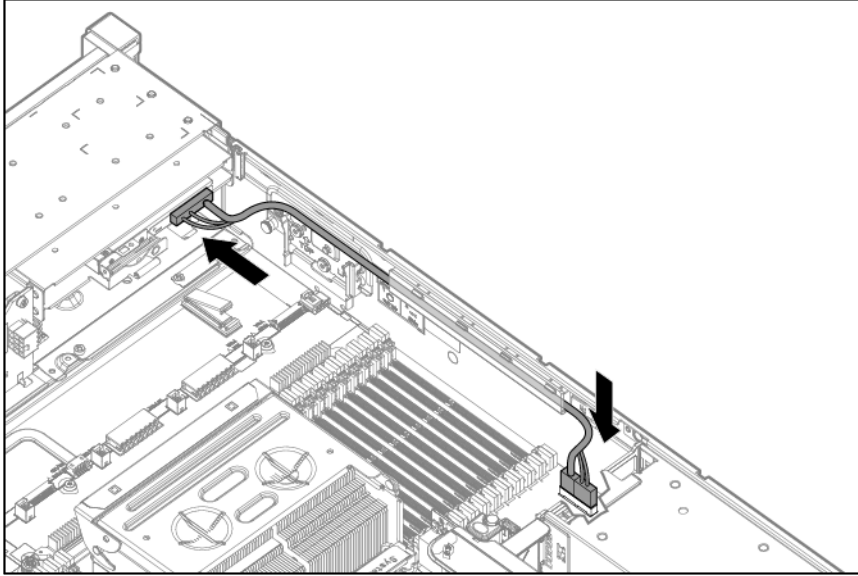

8. Install the access panel (on page 25).
9. Install the server into the rack ("Installing the server into the rack" on page 40).
10. Connect each power cord to the server.
11. Connect each power cord to the power source.
12. Power up the server (on page 23).

Redundant hot-plug power supply option

- CAUTION:** All power supplies installed in the server must have the same output power capacity. Verify that all power supplies have the same part number and label color. The system becomes unstable and may shut down when it detects mismatched power supplies.

Label color	Output
Blue	460W
Orange	750W
White	750W 48V DC
Green	1,200W

- CAUTION:** To prevent improper cooling and thermal damage, do not operate the server unless all bays are populated with either a component or a blank.

- IMPORTANT:** Before selecting power supplies, HP recommends that you run the HP Power Advisor to determine the right size power supply for your server configuration. HP Power Advisor is available as both an online tool, running directly from the HP website, and as a downloadable tool. Instructions on how to download and use the tool are available on the HP website (<http://www.hp.com/go/hppoweradvisor>).

To install the component:

1. Access the product rear panel (on page 25).
2. Remove the blank.



WARNING: To reduce the risk of personal injury from hot surfaces, allow the power supply or power supply blank to cool before touching it.

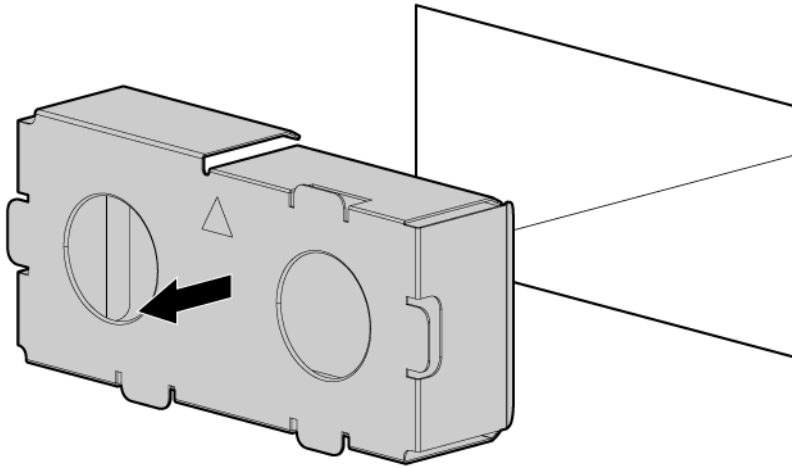

3. Insert the power supply into the power supply bay until it clicks into place.

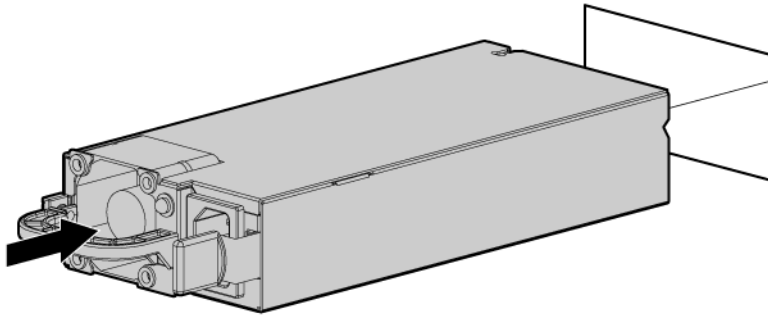

4. Connect the power cord to the power supply.
5. Route the power cord. Use best practices when routing power cords and other cables. A cable management arm is available to help with routing. To obtain a cable management arm, contact an HP authorized reseller.
6. Connect the power cord to the AC power source.
7. Be sure that the power supply LED is green.

FlexibleLOM option



WARNING: To reduce the risk of personal injury, electric shock, or damage to the equipment, remove the power cord to remove power from the server. The front panel Power On/Standby button does not completely shut off system power. Portions of the power supply and some internal circuitry remain active until AC power is removed.

To remove the component:

1. Power down the server (on page 23).
2. Remove all power:
 - a. Disconnect each power cord from the power source.
 - b. Disconnect each power cord from the server.
3. Remove any attached network cables.
4. Extend the server from the rack (on page 23).
5. Remove the access panel (on page 25).
6. Remove the primary PCIe riser cage (on page 29).
7. Loosen the thumbscrew.
8. Remove the existing FlexibleLOM.

Pull the FlexibleLOM toward the front of the server while removing, to avoid catching it on the rear chassis.

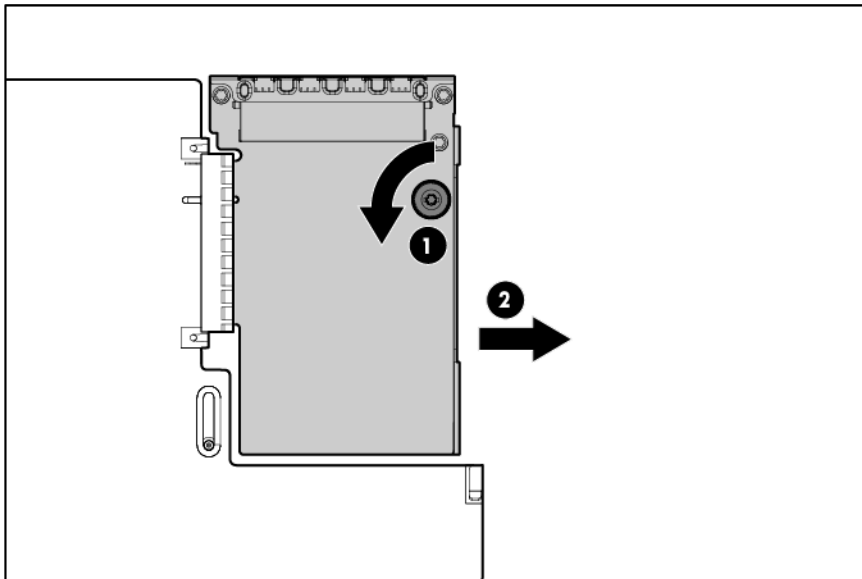

To install the component:

1. Firmly seat the optional FlexibleLOM in the slot, and then tighten the thumbscrew.

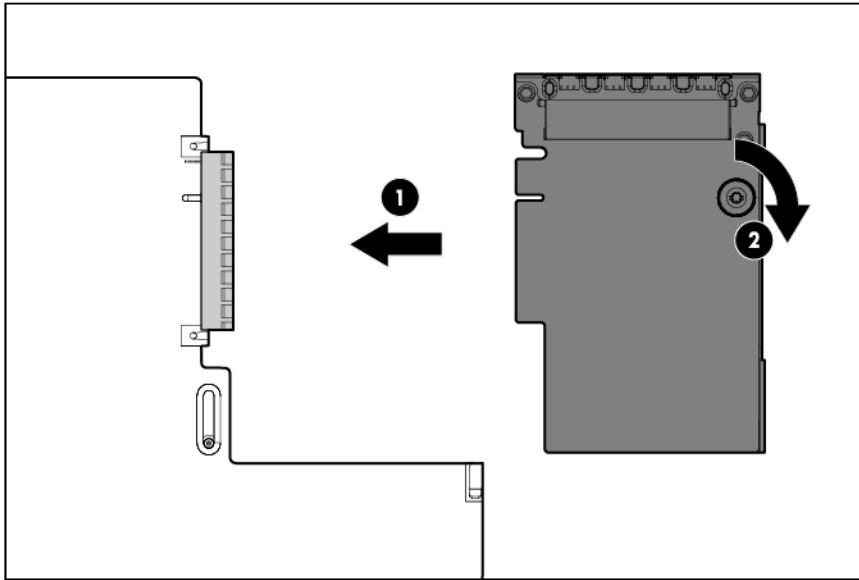

2. Install the primary PCIe riser cage (on page 31).
3. Install the access panel (on page 25).
4. Slide the server into the rack.
5. Connect the LAN segment cables.
6. Connect each power cord to the server.
7. Connect each power cord to the power source.
8. Power up the server (on page 23).

Expansion board options

The server supports PCI Express expansion boards. The server ships with PCIe riser boards and expansion slots. PCIe expansion boards are supported with optional riser boards.

Removing the expansion slot blanks

-
- ⚠ **CAUTION:** To prevent damage to the server or expansion boards, power down the server and remove all AC power cords before removing or installing the PCI riser cage.
-
- ⚠ **CAUTION:** For proper cooling, do not operate the server without the access panel, baffles, expansion slot covers, or blanks installed. If the server supports hot-plug components, minimize the amount of time the access panel is open.
-

To remove the component from either the primary or secondary PCIe riser cage:

1. Power down the server (on page 23).
2. Remove all power:
 - a. Disconnect each power cord from the power source.
 - b. Disconnect each power cord from the server.

3. Extend the server from the rack (on page 23).
4. Remove the access panel (on page 25).
5. If you need to remove a blank from the primary PCIe riser cage, remove the PCIe riser cage ("[Remove the primary PCIe riser cage](#)" on page 29).
6. If you need to remove a blank from the secondary PCIe riser cage, remove the secondary PCIe riser cage (on page 30).
7. Remove the expansion slot blank.

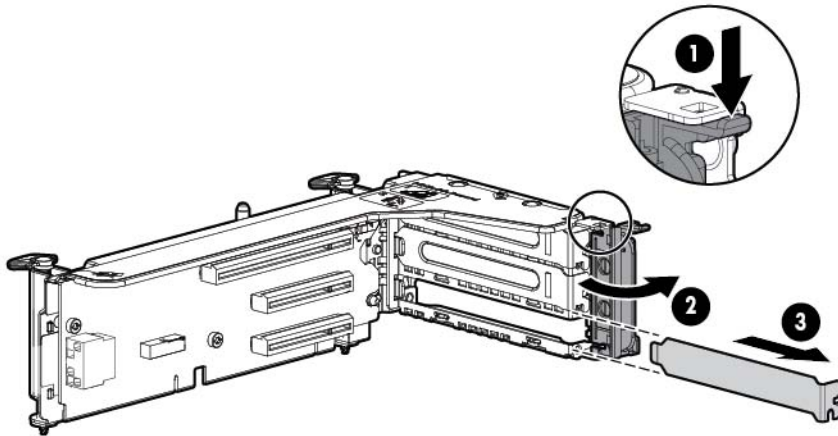

To install the component, reverse the removal procedure.

Installing a half-length expansion board

1. Power down the server (on page 23).
2. Remove all power:
 - a. Disconnect each power cord from the power source.
 - b. Disconnect each power cord from the server.
3. Extend the server from the rack (on page 23).
4. Remove the access panel (on page 25).
5. Do one of the following:
 - o Remove the primary PCIe riser cage (on page 29).
 - o Remove the secondary PCIe riser cage (on page 30).
6. Remove the expansion slot blank ("[Removing the expansion slot blanks](#)" on page 71).

7. Install the expansion board.

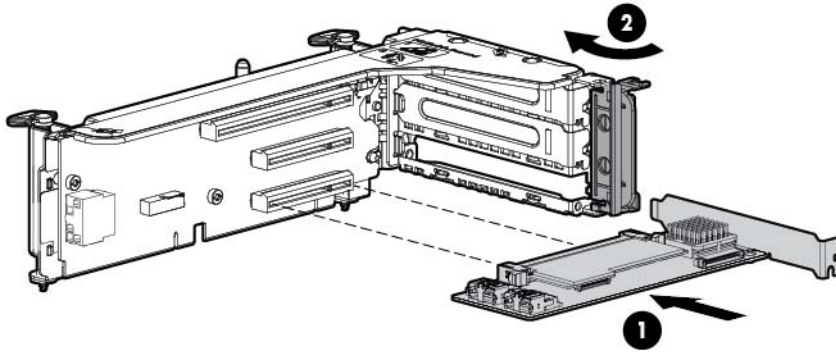

8. Connect any required internal or external cables to the expansion board. See the documentation that ships with the expansion board.
9. Do one of the following:
 - o Install the primary PCIe riser cage (on page 31).
 - o Install the secondary PCIe riser cage ("[Secondary PCIe riser cage option](#)" on page 74).
10. Install the access panel (on page 25).
11. Install the server into the rack ("[Installing the server into the rack](#)" on page 40).
12. Connect each power cord to the server.
13. Connect each power cord to the power source.
14. Power up the server (on page 23).

Installing a full-length expansion board

1. Power down the server (on page 23).
2. Remove all power:
 - a. Disconnect each power cord from the power source.
 - b. Disconnect each power cord from the server.
3. Extend the server from the rack (on page 23).
4. Remove the access panel (on page 25).
5. If a full-length expansion board is installed in the primary PCIe riser cage, release the expansion board retainer and remove the primary PCIe riser cage (on page 29).
6. If a full-length expansion board is installed in the secondary PCIe riser cage, release the expansion board retainer and remove the secondary PCIe riser cage (on page 30).
7. Remove the expansion slot cover ("[Removing the expansion slot blanks](#)" on page 71).
8. Install the expansion board into slot 1.
9. Connect any required internal or external cables to the expansion board. See the documentation that ships with the expansion board.
10. Do one of the following:

- Install the primary PCIe riser cage (on page 31).
 - Install the secondary PCIe riser cage ("Secondary PCIe riser cage option" on page 74).
11. Do one of the following:
 - Secure the primary PCIe riser cage full-length expansion board retainer (on page 32).
 - Secure the secondary PCIe riser cage full-length expansion board retainer (on page 33).
 12. Install the access panel (on page 25).
 13. Install the server into the rack ("Installing the server into the rack" on page 40).
 14. Connect each power cord to the server.
 15. Connect each power cord to the power source.
 16. Power up the server (on page 23).

Secondary PCIe riser cage option



WARNING: To reduce the risk of personal injury, electric shock, or damage to the equipment, remove the power cord to remove power from the server. The front panel Power On/Standby button does not completely shut off system power. Portions of the power supply and some internal circuitry remain active until AC power is removed.



CAUTION: To prevent improper cooling and thermal damage, do not operate the server unless all PCI slots have either an expansion slot cover or an expansion board installed.



IMPORTANT: The secondary PCI riser cage option requires both processors.

To install the component:

1. Power down the server (on page 23).
2. Remove all power:
 - a. Disconnect each power cord from the power source.
 - b. Disconnect each power cord from the server.
3. Extend the server from the rack (on page 23).
4. Remove the access panel (on page 25).

5. Remove the PCI riser blank.

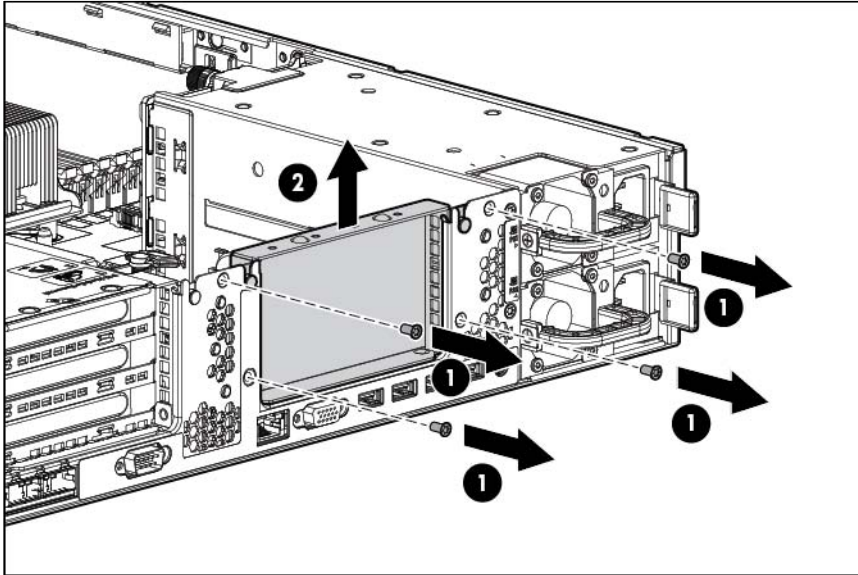

6. Remove the blank from the optional secondary PCI riser cage.

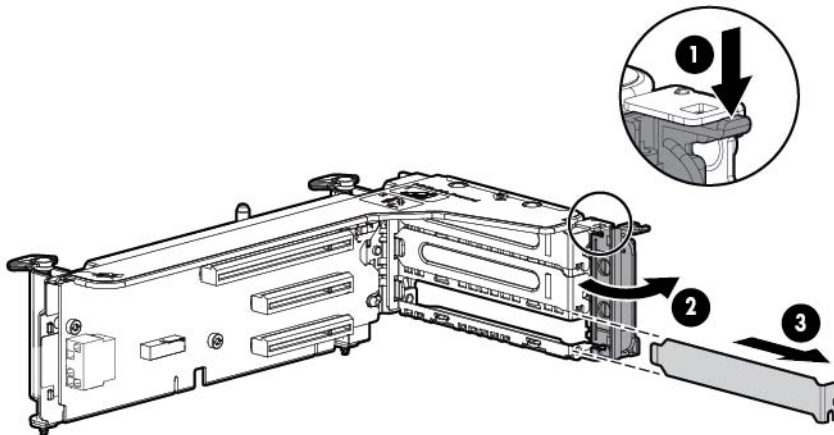

7. Install an expansion board into the PCI riser cage, if needed.

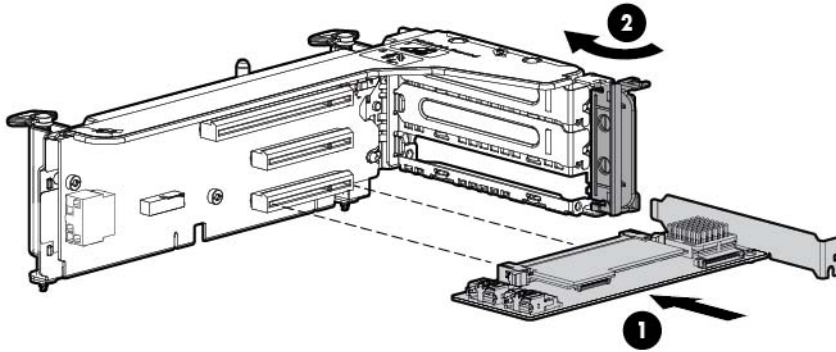

8. Connect any internal or external cables.
9. Install the optional secondary PCIe riser cage.

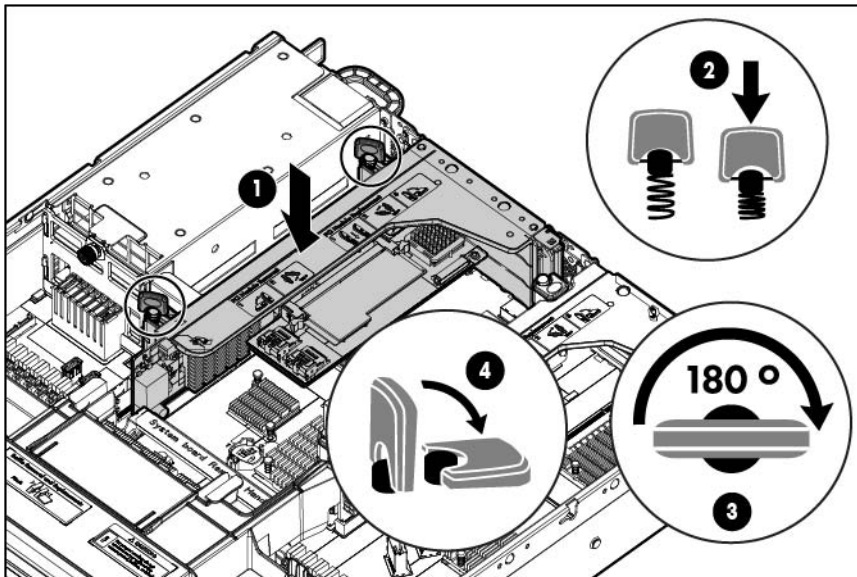

10. If not already installed, install the secondary processor ("[Processor option](#)" on page 44).
11. Install the access panel (on page 25).
12. Install the server into the rack ("[Installing the server into the rack](#)" on page 40).
13. Connect each power cord to the server.
14. Connect each power cord to the power source.
15. Power up the server (on page 23).

Hard drive cage option

An additional SAS controller option is required to support the hard drive cage option.

To install the component:

1. Power down the server (on page 23).
2. Remove all power:
 - a. Disconnect each power cord from the power source.
 - b. Disconnect each power cord from the server.
3. Extend the server from the rack (on page 23).
4. Remove the access panel (on page 25).
5. If a full-length expansion board is installed in slot 1, release the full-length expansion board retainer, and then remove the primary PCIe riser cage.

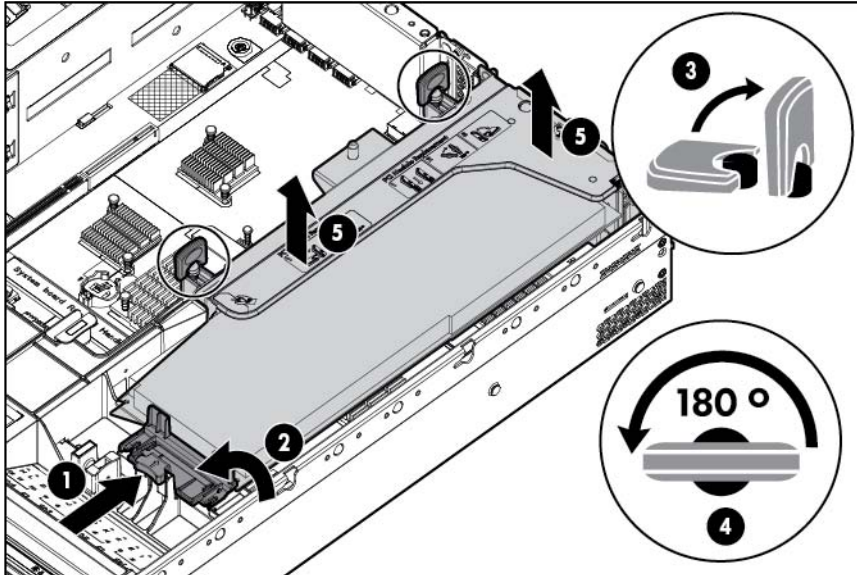

6. If a full-length expansion board is installed in slot 4, release the full-length expansion board retainer, and then remove the secondary PCIe riser cage.

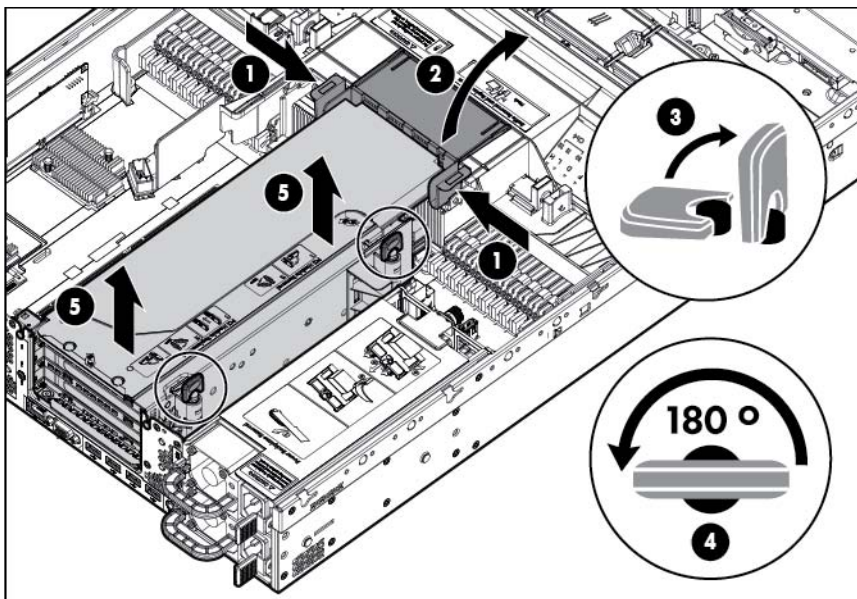

7. Remove the air baffle (on page 34).

8. Remove the fan cage.

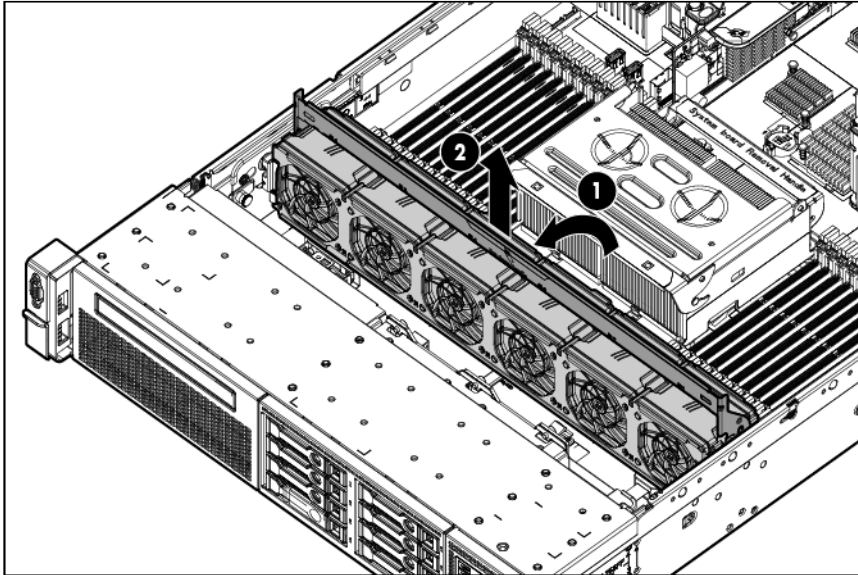

9. Disconnect and remove the optical drive cable, if installed:
 - a. Disconnect the cable.

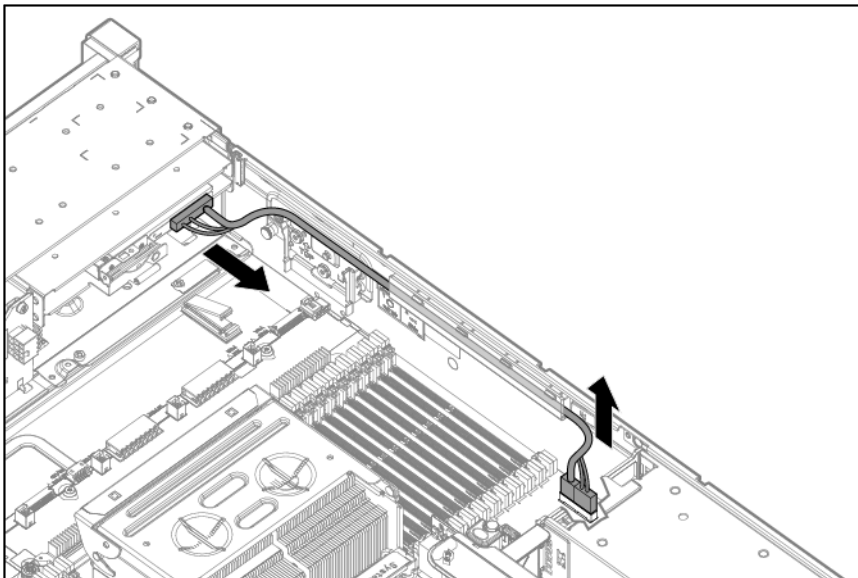

- b. Remove the cable from the DIMM guard.

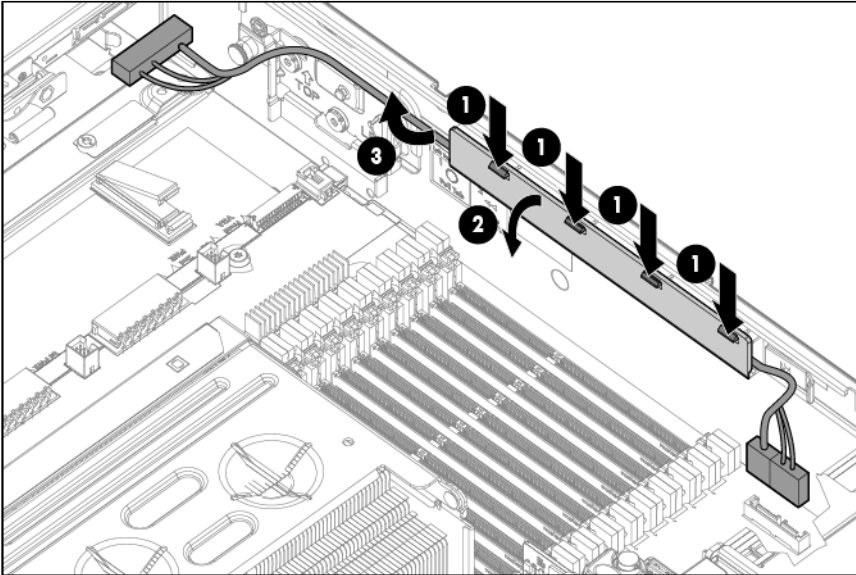

10. Using a T-15 Torx screwdriver, remove the two optical drive retaining screws, and then remove the optical drive cage.

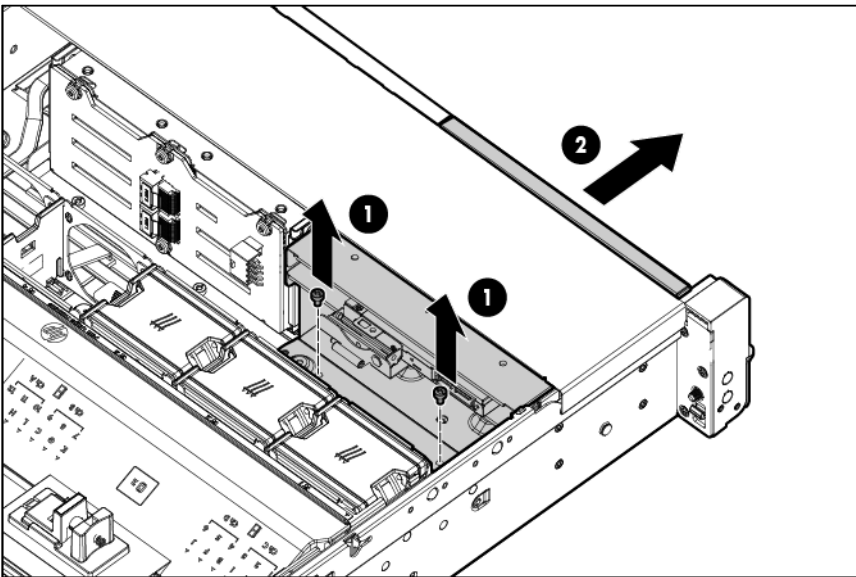

11. Install the optional hard drive cage.

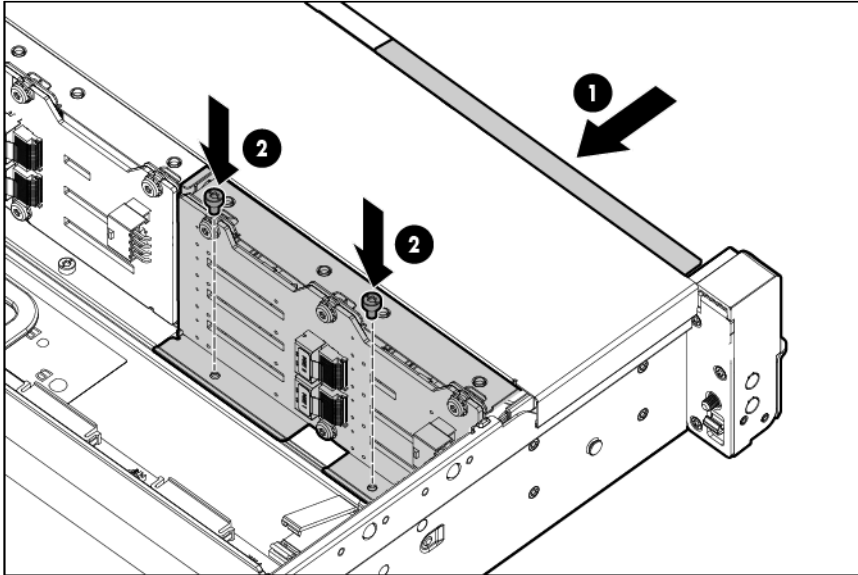

12. Install the hard drives or hard drive blanks.
13. To access the cables, remove the fan bracket on the right side of the chassis.

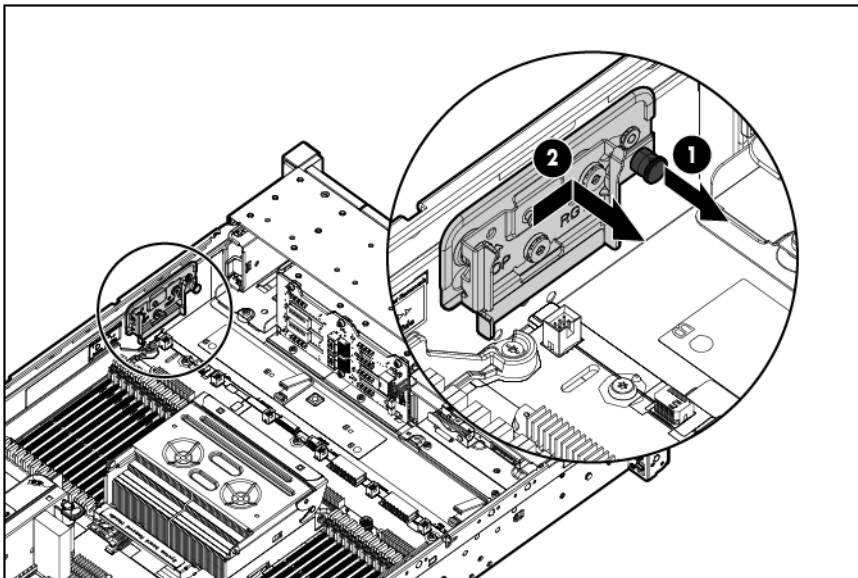

14. Connect the cables:

- a. Connect one end of the power cable to the SAS backplane and the other end to the power connector on the system board.

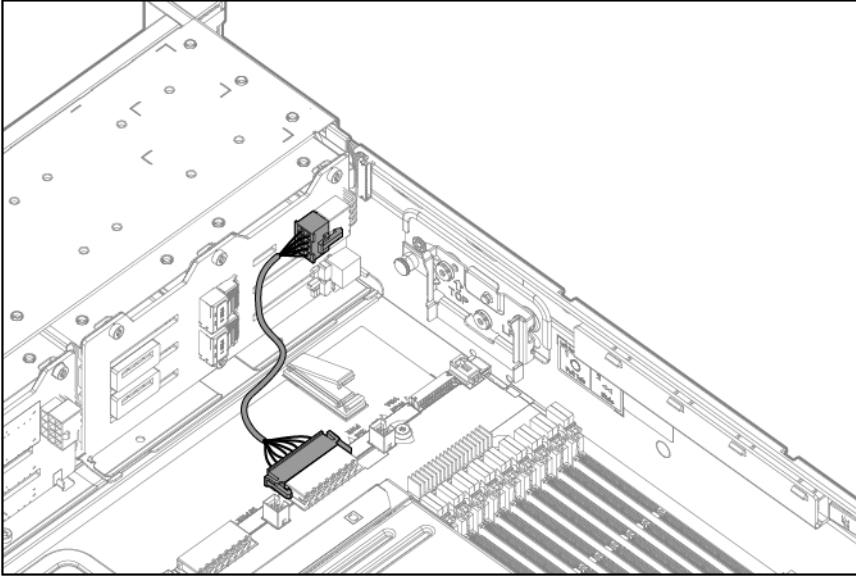

- b. Remove the existing SAS cable from the cable guide and from the system board.

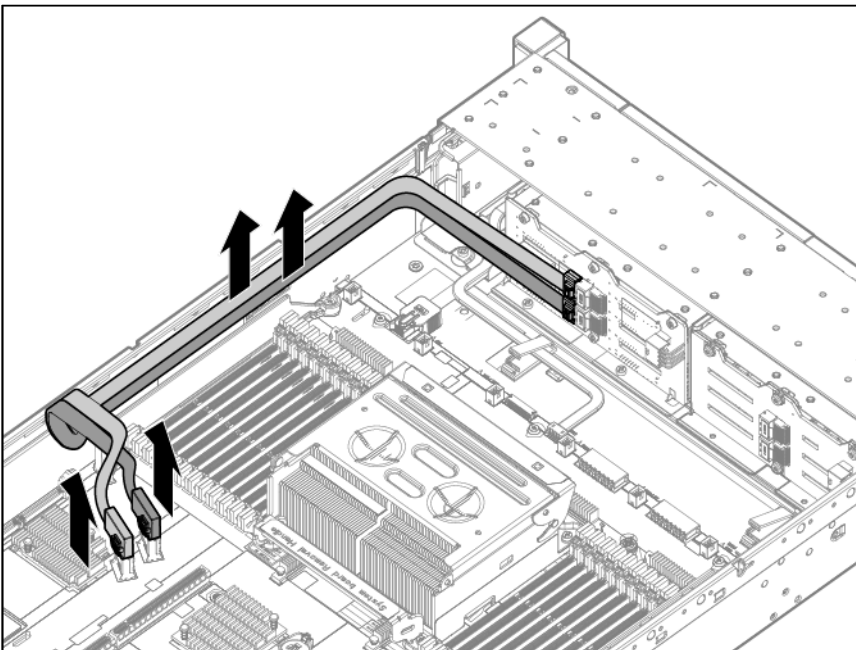

15. Connect the end of each SAS signal cable to the SAS backplane, and then route the SAS signal cables behind the cable guide. Do not connect the other ends yet.

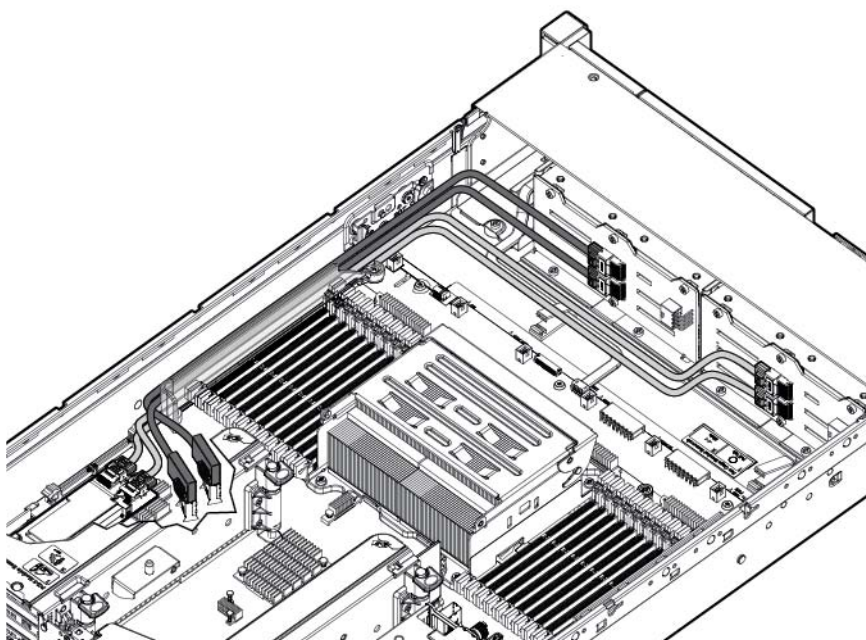

16. Install the fan bracket. Be sure that the cables are properly routed in the channel along the fan bracket.

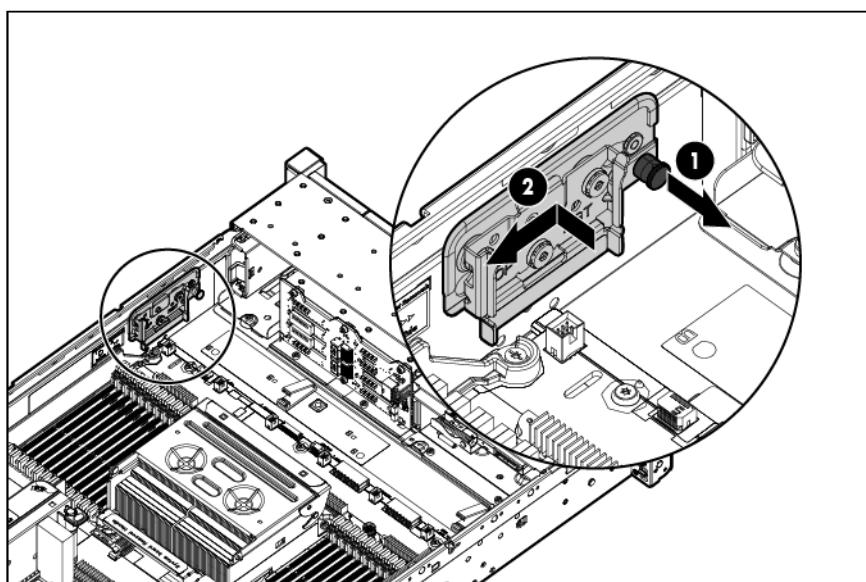

17. Install the fan cage.

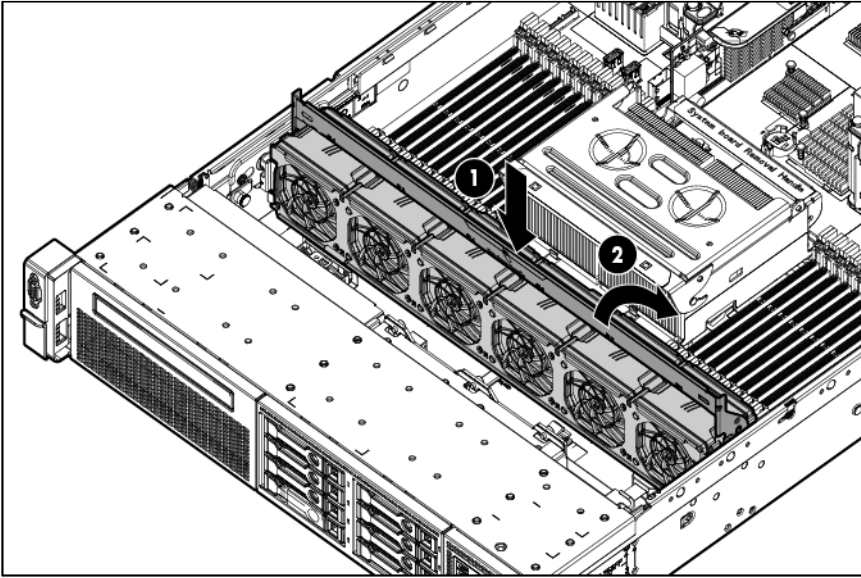

18. Install the air baffle.

If you do not have a full-length expansion board, the air baffle can be installed last.

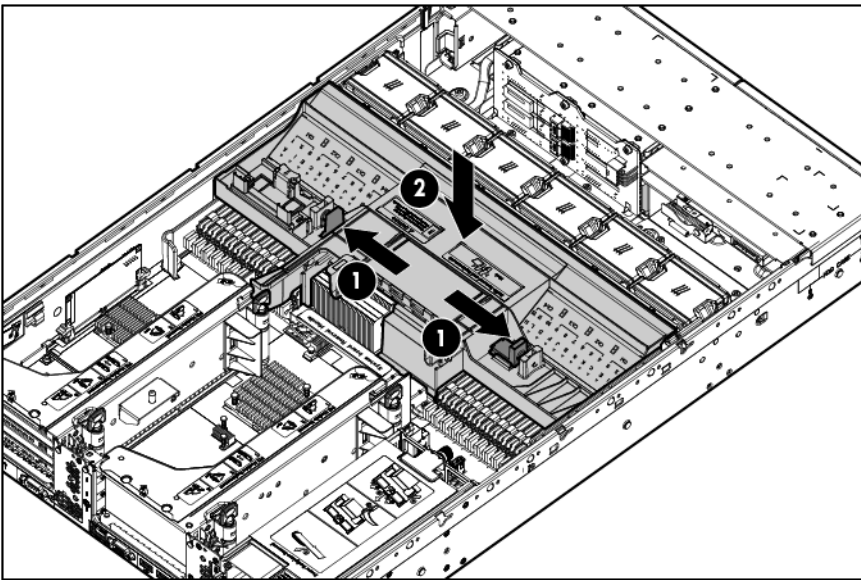

19. Remove the blank from the PCIe riser cage.

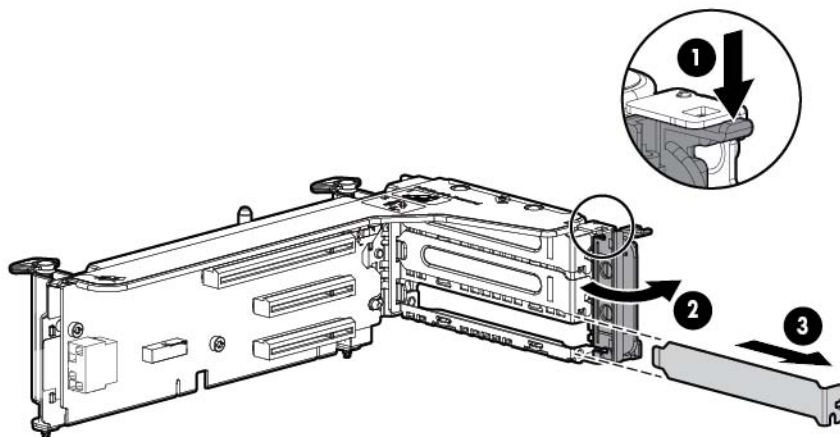

20. Install the SAS controller board into the PCIe riser cage.

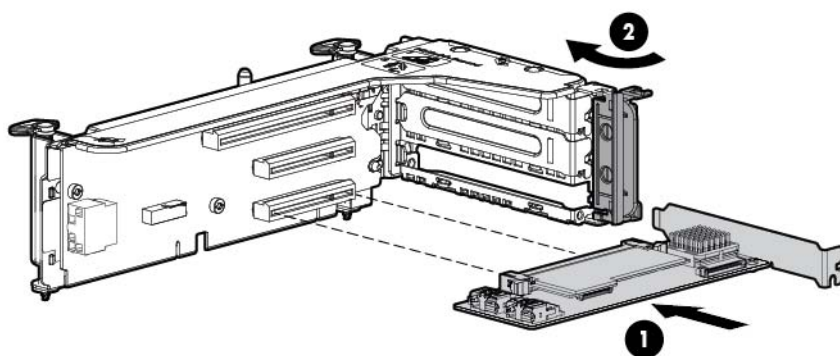

21. Connect the other end of the SAS signal cables to the SAS controller board and to the system board. Then, install the PCIe riser cage.

SAS cables can be connected to the PCIe riser cage and the system board before or after the PCIe riser cage is installed. For ease in accessing connectors, HP recommends connecting the cables before the PCIe riser cage is installed.

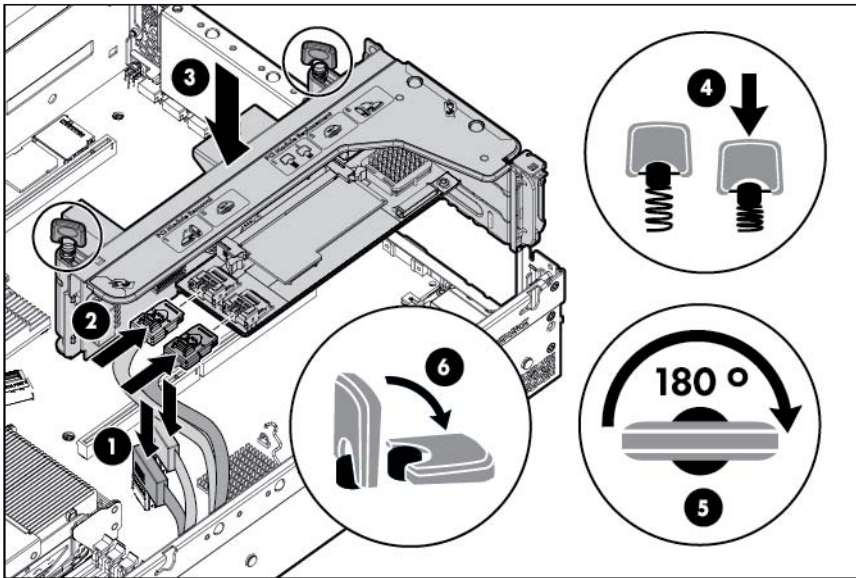

Completed SAS cabling:

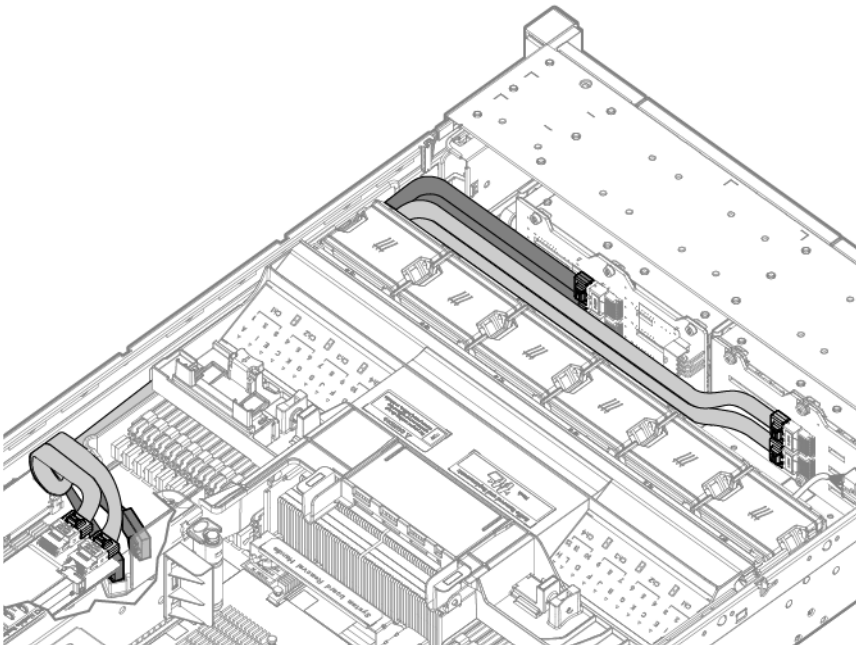

22. Make sure any installed full-length expansion boards are seated in the retainer clip on the air baffle.
23. Install the access panel (on page 25).
24. Install the server into the rack.
25. Connect each power cord to the server.
26. Connect each power cord to the power source.
27. Power up the server (on page 23).

2U rack bezel option

The 2U rack bezel helps prevent any unauthorized physical access to the server in the rack configuration. To access the hard drive cage, you must unlock and open the 2U rack bezel.

To unlock the 2U rack bezel, use the key provided with the kit.

Install the 2U rack bezel into the chassis, and then lock the 2U rack bezel with the key.

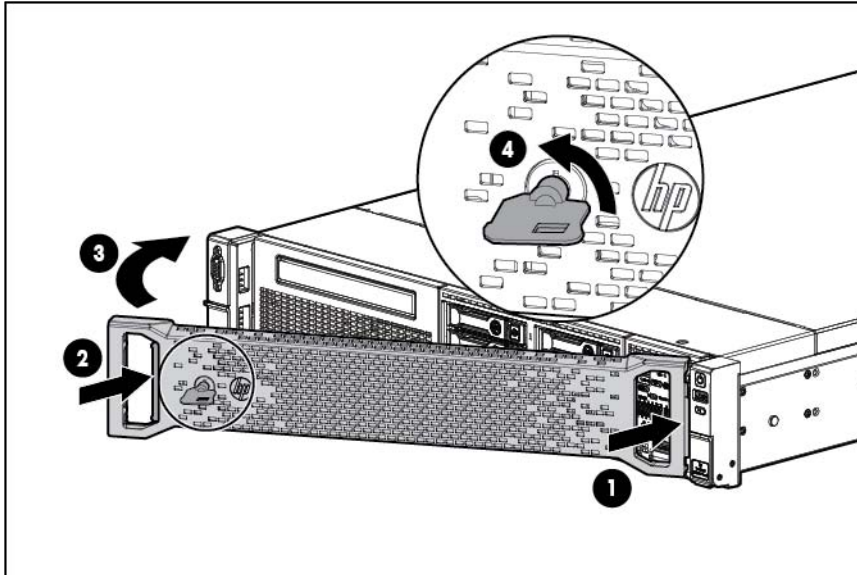

HP Trusted Platform Module option

For more information about product features, specifications, options, configurations, and compatibility, see the product QuickSpecs on the HP Product Bulletin website (<http://www.hp.com/go/productbulletin>).

Use these instructions to install and enable a TPM on a supported server. This procedure includes three sections:

1. Installing the Trusted Platform Module board.
2. Retaining the recovery key/password (on page 89).
3. Enabling the Trusted Platform Module (on page 89).

Enabling the TPM requires accessing RBSU ("HP ROM-Based Setup Utility" on page 103). For more information about RBSU, see the HP website (<http://www.hp.com/go/ilomgmtengine/docs>).

TPM installation requires the use of drive encryption technology, such as the Microsoft Windows BitLocker Drive Encryption feature. For more information on BitLocker, see the Microsoft website (<http://www.microsoft.com>).

CAUTION: Always observe the guidelines in this document. Failure to follow these guidelines can cause hardware damage or halt data access.

When installing or replacing a TPM, observe the following guidelines:

- Do not remove an installed TPM. Once installed, the TPM becomes a permanent part of the system board.

- When installing or replacing hardware, HP service providers cannot enable the TPM or the encryption technology. For security reasons, only the customer can enable these features.
- When returning a system board for service replacement, do not remove the TPM from the system board. When requested, HP Service provides a TPM with the spare system board.
- Any attempt to remove an installed TPM from the system board breaks or disfigures the TPM security rivet. Upon locating a broken or disfigured rivet on an installed TPM, administrators should consider the system compromised and take appropriate measures to ensure the integrity of the system data.
- When using BitLocker, always retain the recovery key/password. The recovery key/password is required to enter Recovery Mode after BitLocker detects a possible compromise of system integrity.
- HP is not liable for blocked data access caused by improper TPM use. For operating instructions, see the encryption technology feature documentation provided by the operating system.

Installing the Trusted Platform Module board

 **WARNING:** To reduce the risk of personal injury, electric shock, or damage to the equipment, remove the power cord to remove power from the server. The front panel Power On/Standby button does not completely shut off system power. Portions of the power supply and some internal circuitry remain active until AC power is removed.

 **WARNING:** To reduce the risk of personal injury from hot surfaces, allow the drives and the internal system components to cool before touching them.

1. Power down the server (on page [23](#)).
2. Remove all power:
 - a. Disconnect each power cord from the power source.
 - b. Disconnect each power cord from the server.
3. Remove the server from the rack, if necessary ("[Remove the server from the rack](#)" on page [24](#)).
4. Place the server on a flat, level work surface.
5. Remove the access panel (on page [25](#)).
6. Do the following:
 - a. Remove the primary PCIe riser cage (on page [29](#)).
 - b. Remove the secondary PCIe riser cage (on page [30](#)).
7. Remove the air baffle (on page [34](#)).

 **CAUTION:** Any attempt to remove an installed TPM from the system board breaks or disfigures the TPM security rivet. Upon locating a broken or disfigured rivet on an installed TPM, administrators should consider the system compromised and take appropriate measures to ensure the integrity of the system data.

8. Install the TPM board. Press down on the connector to seat the board ("[System board components](#)" on page [15](#)).

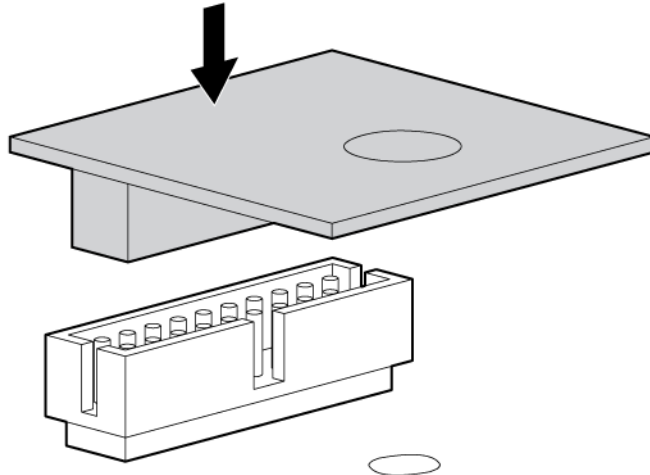

9. Install the TPM security rivet by pressing the rivet firmly into the system board.

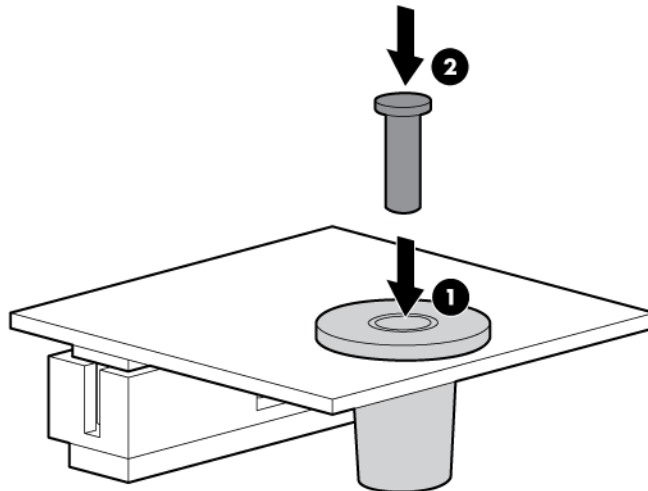

10. Install the air baffle.
11. Do the following:
 - a. Install the primary PCIe riser cage (on page [31](#)).
 - b. Install the secondary PCIe riser cage ("[Secondary PCIe riser cage option](#)" on page [74](#)).
12. Install the access panel (on page [25](#)).
13. Install the server into the rack ("[Installing the server into the rack](#)" on page [40](#)).
14. Connect each power cord to the server.
15. Connect each power cord to the power source.
16. Power up the server (on page [23](#)).

Retaining the recovery key/password

The recovery key/password is generated during BitLocker™ setup, and can be saved and printed after BitLocker™ is enabled. When using BitLocker™, always retain the recovery key/password. The recovery key/password is required to enter Recovery Mode after BitLocker™ detects a possible compromise of system integrity.

To help ensure maximum security, observe the following guidelines when retaining the recovery key/password:

- Always store the recovery key/password in multiple locations.
- Always store copies of the recovery key/password away from the server.
- Do not save the recovery key/password on the encrypted hard drive.

Enabling the Trusted Platform Module

1. When prompted during the start-up sequence, access RBSU by pressing the **F9** key.
2. From the Main Menu, select **Server Security**.
3. From the Server Security Menu, select **Trusted Platform Module**.
4. From the Trusted Platform Module Menu, select **TPM Functionality**.
5. Select **Enable**, and then press the **Enter** key to modify the TPM Functionality setting.
6. Press the **Esc** key to exit the current menu, or press the **F10** key to exit RBSU.
7. Reboot the server.
8. Enable the TPM in the OS. For OS-specific instructions, see the OS documentation.



CAUTION: When a TPM is installed and enabled on the server, data access is locked if you fail to follow the proper procedures for updating the system or option firmware, replacing the system board, replacing a hard drive, or modifying OS application TPM settings.

For more information on firmware updates and hardware procedures, see the *HP Trusted Platform Module Best Practices White Paper* on the HP website (<http://www.hp.com/support>).

For more information on adjusting TPM usage in BitLocker™, see the Microsoft website (<http://technet.microsoft.com/en-us/library/cc732774.aspx>).

Cabling

SAS hard drive cabling

- SFF hard drive cabling

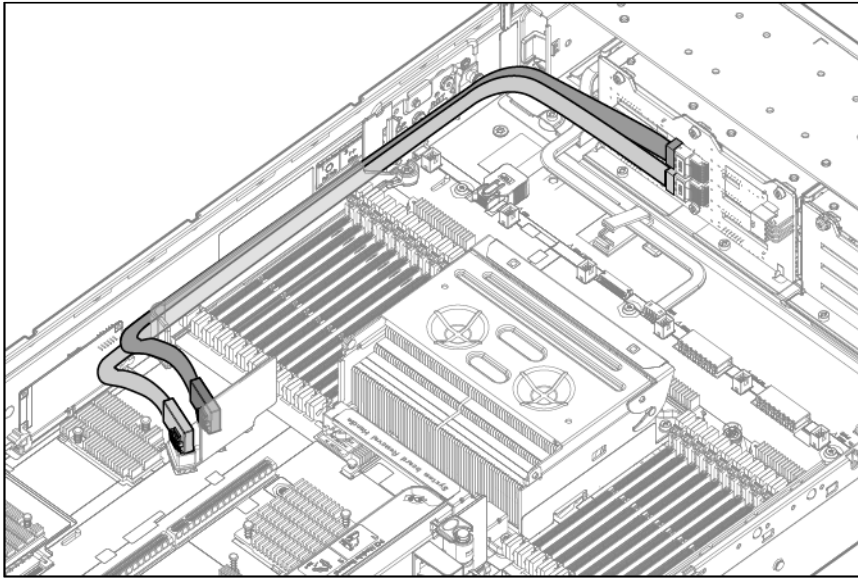

- SFF cabling, with optional drive cage

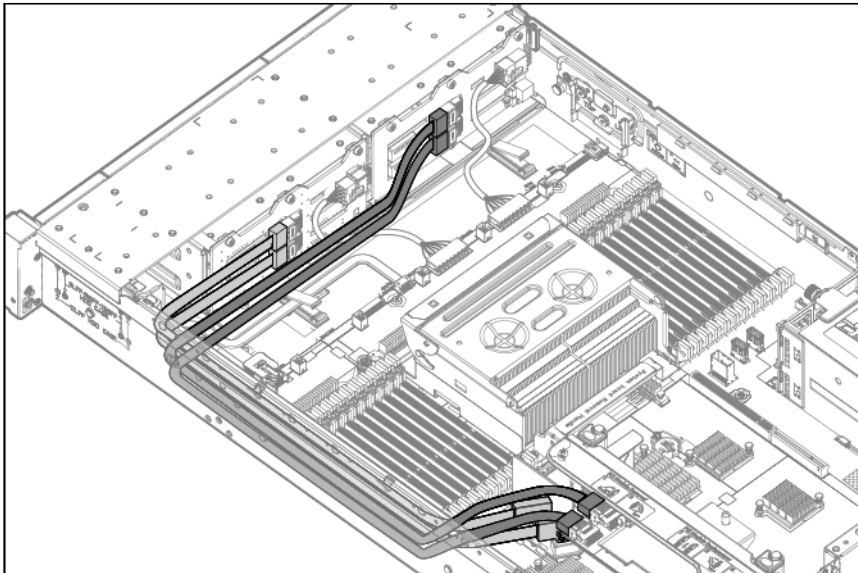

- LFF hard drive cabling

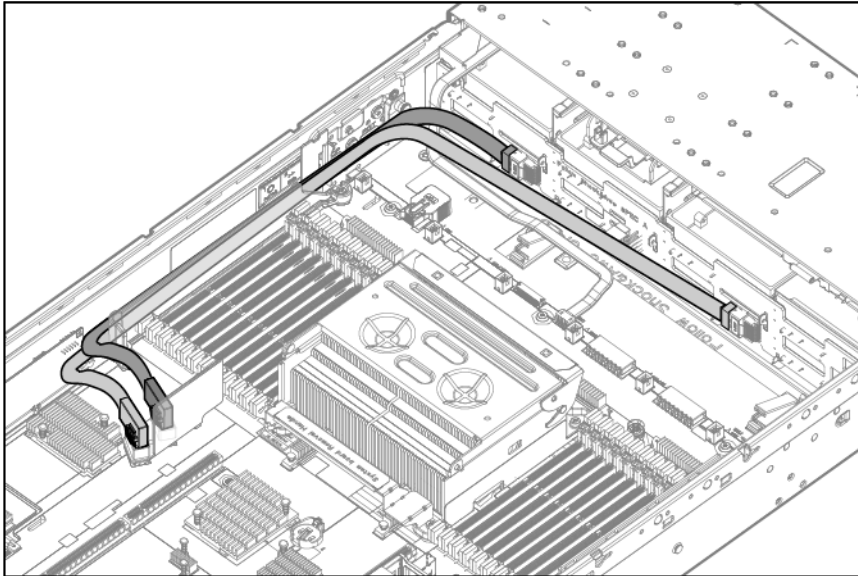

Optical drive cabling

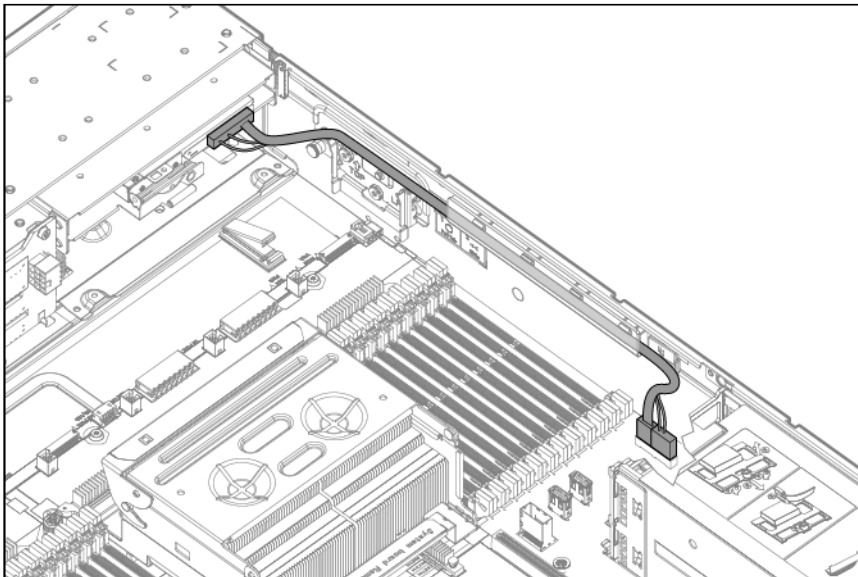

FBWC cabling

- 8 or 16 drive SFF

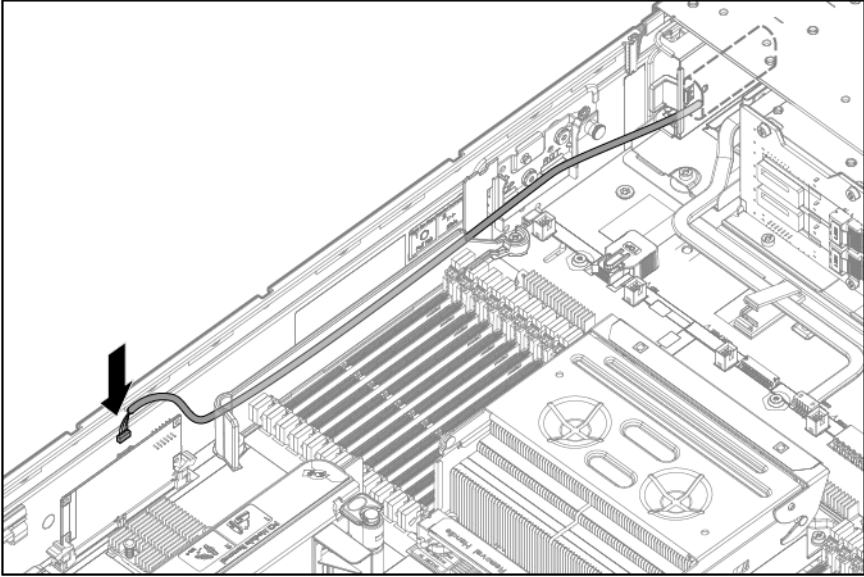

- 8 drive LFF

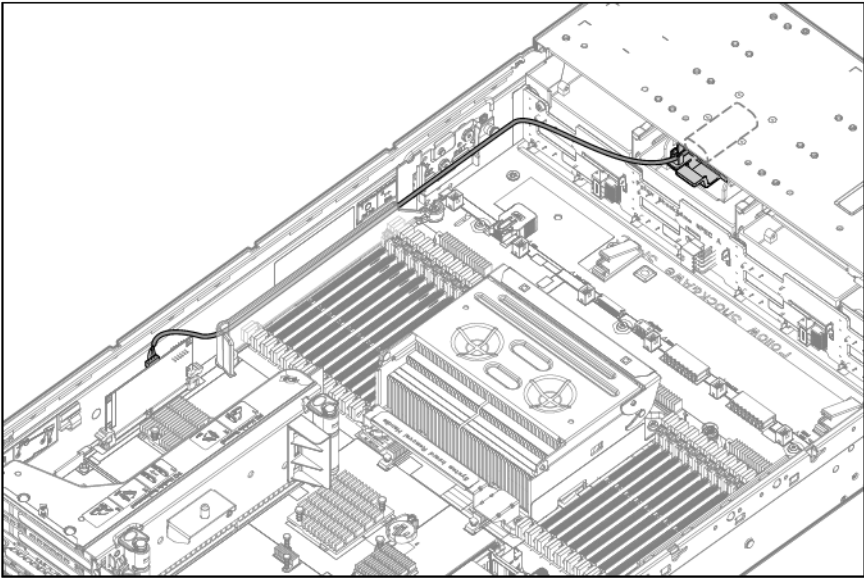

- 12 LFF or 25 SFF

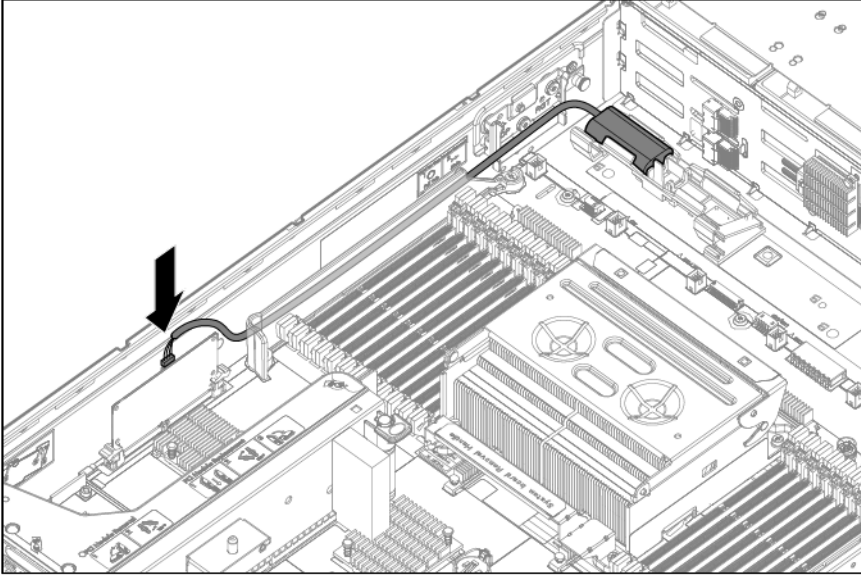

- PCIe option

Depending on the server configuration, you may need to remove the primary PCIe riser cage (on page 29) before cabling to a PCIe expansion board.

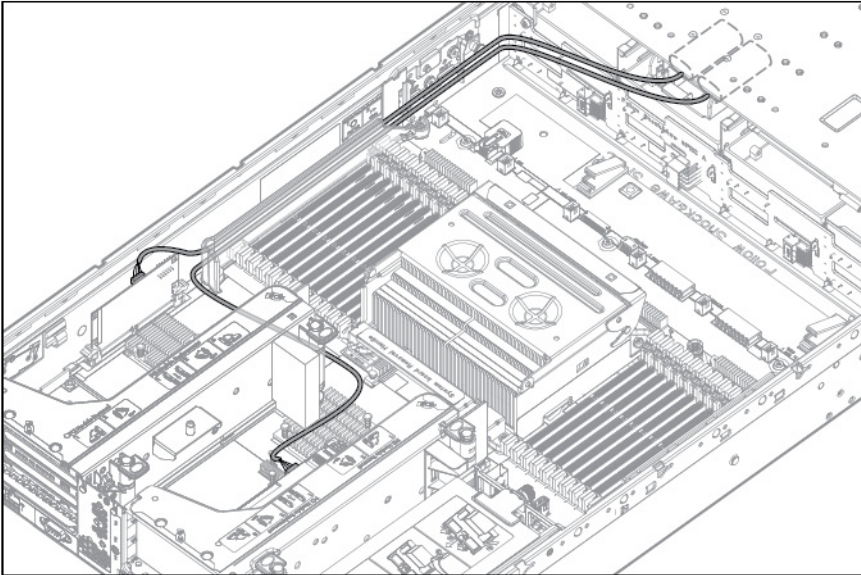

Chipset SATA cable option

With the chipset SATA cable option, the chipset SATA controller can be used with a single SATA hard drive that is installed in one hard drive bay of the SFF or LFF hard drive cage.

- When using the chipset SATA configuration, the following conditions apply:
 - Only drive bay 5 is enabled. The remaining drive bays are disabled.
 - The optical bay is disabled because the chipset SATA controller port on the system board is redirected from the optical bay to the drive cage.

- Hard drive status LEDs are not supported.
- Hard drive thermal status monitoring is not supported.
- Hot-plug operation is not supported.
- Because only one drive bay is enabled, all remaining drives can be removed.
For proper thermal cooling, install blanks in all bays that do not have a drive installed. Order a sufficient number of 6.35-cm (2.5-in) or 8.89-cm (3.5-in) hard drive blank option kits from an HP authorized reseller. For more information, see the server maintenance and service guide.
- The standard SATA driver is included with supported operating systems. No additional driver is required.

To install the component:

1. Power down the server (on page 23).
2. Remove all power:
 - a. Disconnect each power cord from the power source.
 - b. Disconnect each power cord from the server.
3. Extend the server from the rack (on page 23).
4. Remove the access panel (on page 25).

 **WARNING:** Eliminate the risk of electric shock by removing all AC power from the system before installing or replacing any non-hot-plug hardware option. Disconnect all power cords to completely remove power from the server.

 **WARNING:** To reduce the risk of personal injury from hot surfaces, allow the drives and the internal system components to cool before touching them.

 **IMPORTANT:** You have to remove the primary PCIe riser cage if a full-length expansion board is installed.

5. If a full-length expansion board is installed in slot 1, release the full-length expansion board retainer, and then remove the primary PCIe riser cage.

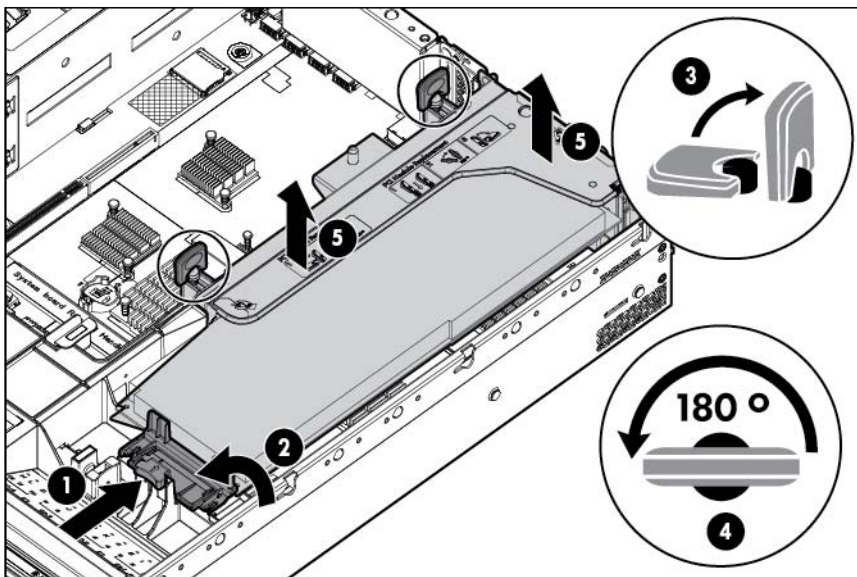

6. If a full-length expansion board is installed in slot 4, release the full-length expansion board retainer, and then remove the secondary PCIe riser cage.

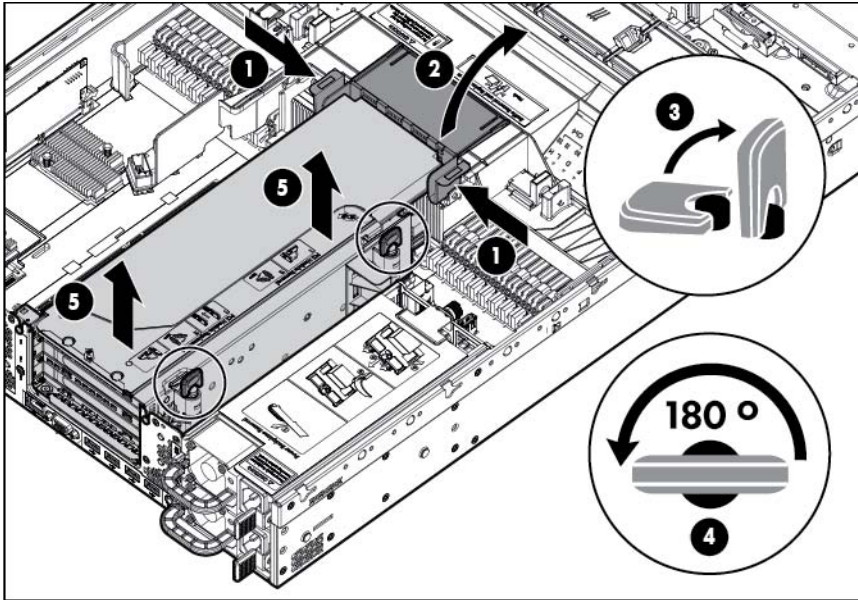

7. Remove the air baffle (on page 34).
8. Remove the fan cage (on page 26).
9. Disconnect any SAS cables from the hard drive cage and either the embedded SAS controller or an optional SAS controller. Do not disconnect the power cable.

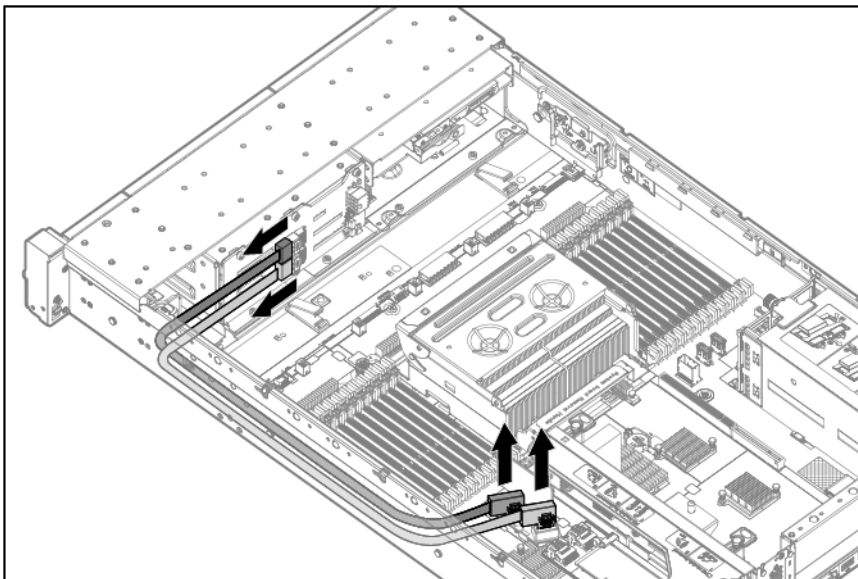

10. Disconnect the SATA cable from the optical drive and the SATA connector on the system board. The optical bay is disabled with the chipset SATA cable option.

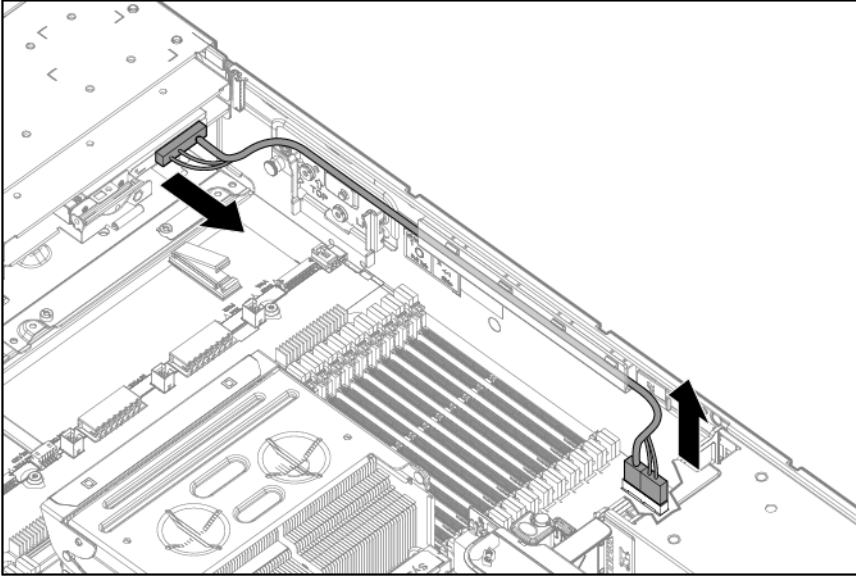

11. Connect the chipset SATA cable:
 - a. Connect the chipset SATA cable connector to the chipset SATA controller port on the system board. The chipset SATA connector on the SATA cable is narrower than the chipset SATA controller port header on the system board.
 - b. Connect the remaining chipset SATA cable connector to the SATA header on the hard drive cage.

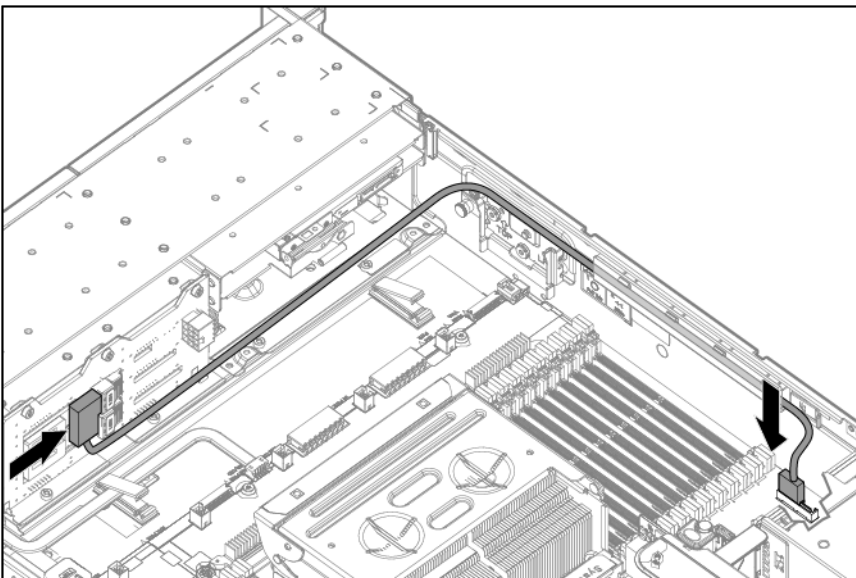

12. Coil the cables behind the hard drive backplane to minimize airflow impact.
13. Install the fan cage ("[Remove the fan cage](#)" on page 26).
14. Install the air baffle ("[Remove the air baffle](#)" on page 34).
15. Install the PCIe riser cage ("[Install the primary PCIe riser cage](#)" on page 31), if removed.
16. Do one of the following:
 - o Secure the primary PCIe riser cage full-length expansion board retainer (on page 32).

- Secure the secondary PCIe riser cage full-length expansion board retainer (on page 33).
- 17. Install the access panel (on page 25).
- 18. Install the server in the rack ("Installing the server into the rack" on page 40).
- 19. Remove any installed hard drives ("Removing a hot-plug SAS or SATA hard drive" on page 60).
- 20. Install a SATA hard drive ("Installing a hot-plug SAS or SATA hard drive" on page 59) in hard drive bay 5.
- 21. Install hard drive blanks in any empty hard drive bays.
- 22. Connect each power cord to the server.
- 23. Connect each power cord to the power source.
- 24. Power up the server (on page 23).
- 25. Use RBSU ("HP ROM-Based Setup Utility" on page 103) to disable the embedded HP Smart Array P420i Controller, if necessary.

150W PCIe power cable option

⚠ CAUTION: To prevent damage to the server or expansion boards, power down the server and remove all AC power cords before removing or installing the PCI expansion cage.

Connect the cable as indicated.

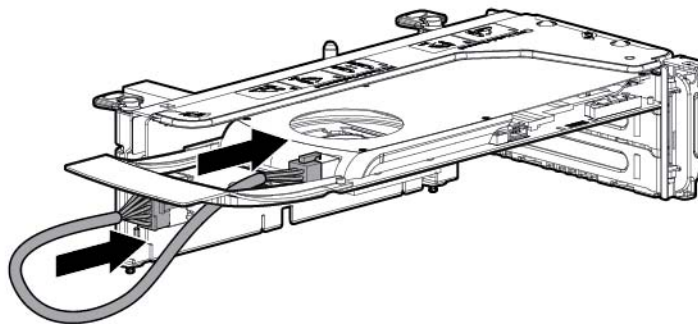

Software and configuration utilities

Server mode

The software and configuration utilities presented in this section operate in online mode, offline mode, or in both modes.

Software or configuration utility	Server mode
HP iLO (on page 98)	Online and Offline
Active Health System (on page 99)	Online and Offline
Integrated Management Log (on page 100)	Online and Offline
Intelligent Provisioning (on page 100)	Offline
HP Insight Diagnostics (on page 101)	Online and Offline
HP Insight Remote Support software (on page 102)	Online
HP Insight Online	Online
Erase Utility (on page 101)	Offline
Scripting Toolkit (on page 102)	Online
HP Service Pack for ProLiant (on page 102)	Online and Offline
HP Smart Update Manager (on page 103)	Online and Offline
HP ROM-Based Setup Utility (on page 103)	Offline
Array Configuration Utility (on page 106)	Online and Offline
Option ROM Configuration for Arrays (on page 107)	Offline
ROMPaq utility (on page 107)	Offline

HP product QuickSpecs

For more information about product features, specifications, options, configurations, and compatibility, see the product QuickSpecs on the HP Product Bulletin website (<http://www.hp.com/go/productbulletin>).

HP iLO Management Engine

The HP iLO Management Engine is a set of embedded management features supporting the complete lifecycle of the server, from initial deployment through ongoing management.

HP iLO

The HP iLO subsystem is a standard component of selected HP ProLiant servers that simplifies initial server setup, server health monitoring, power and thermal optimization, and remote server administration. The HP iLO subsystem includes an intelligent microprocessor, secure memory, and a dedicated network interface. This design makes HP iLO independent of the host server and its operating system.

HP iLO enables and manages the Active Health System (on page 99) and also features Agentless Management. All key internal subsystems are monitored by HP iLO. SNMP alerts are sent directly by HP iLO regardless of the host operating system or even if no host operating system is installed.

Using HP iLO, you can do the following:

- Access a high-performance and secure Remote Console to the server from anywhere in the world.
- Use the shared HP iLO Remote Console to collaborate with up to six server administrators.
- Remotely mount high-performance Virtual Media devices to the server.
- Securely and remotely control the power state of the managed server.
- Have true Agentless Management with SNMP alerts from HP iLO regardless of the state of the host server.
- Access Active Health System troubleshooting features through the HP iLO interface.

For more information about HP iLO features (which may require an iLO Advanced Pack or iLO Advanced for BladeSystem license), see the HP iLO documentation on the Documentation CD or on the HP website (<http://www.hp.com/go/ilo/docs>).

Active Health System

HP Active Health System provides the following features:

- Combined diagnostics tools/scanners
- Always on, continuous monitoring for increased stability and shorter downtimes
- Rich configuration history
- Health and service alerts
- Easy export and upload to Service and Support

The HP Active Health System monitors and records changes in the server hardware and system configuration. The Active Health System assists in diagnosing problems and delivering rapid resolution when server failures occur.

The Active Health System collects the following types of data:

- Server model
- Serial number
- Processor model and speed
- Storage capacity and speed
- Memory capacity and speed
- Firmware/BIOS

HP Active Health System does not collect information about Active Health System users' operations, finances, customers, employees, partners, or data center, such as IP addresses, host names, user names, and passwords. HP Active Health System does not parse or change operating system data from third-party error event log activities, such as content created or passed through by the operating system.

The data that is collected is managed according to the HP Data Privacy policy. For more information see the HP website (<http://www.hp.com/go/privacy>).

The Active Health System log, in conjunction with the system monitoring provided by Agentless Management or SNMP Pass-thru, provides continuous monitoring of hardware and configuration changes, system status, and service alerts for various server components.

The Agentless Management Service is available in the SPP, which is a disk image (.iso) that you can download from the HP website (<http://www.hp.com/go/spp/download>). The Active Health System log can be downloaded manually from HP iLO or HP Intelligent Provisioning and sent to HP. For more information, see the *HP iLO User Guide* or *HP Intelligent Provisioning User Guide* on the HP website (<http://www.hp.com/go/ilo/docs>).

Integrated Management Log

The IML records hundreds of events and stores them in an easy-to-view form. The IML timestamps each event with 1-minute granularity.

You can view recorded events in the IML in several ways, including the following:

- From within HP SIM
- From within operating system-specific IML viewers
 - For Windows: IML Viewer
 - For Linux: IML Viewer Application
- From within the HP iLO user interface
- From within HP Insight Diagnostics (on page 101)

Intelligent Provisioning

Several packaging changes have taken place with HP ProLiant Gen8 servers: SmartStart CDs and the Smart Update Firmware DVD will no longer ship with these new servers. Instead, the deployment capability is embedded in the server as part of HP iLO Management Engine's Intelligent Provisioning.

Intelligent Provisioning is an essential single-server deployment tool embedded in HP ProLiant Gen8 servers that simplifies HP ProLiant server setup, providing a reliable and consistent way to deploy HP ProLiant server configurations.

- Intelligent Provisioning assists with the OS installation process by preparing the system for installing "off-the-shelf" versions of leading operating system software and automatically integrating optimized HP ProLiant server support software from SPP. SPP is the installation package for operating system-specific bundles of HP ProLiant optimized drivers, utilities, management agents, and system firmware.
- Intelligent Provisioning provides maintenance-related tasks through Perform Maintenance features.
- Intelligent Provisioning provides installation help for Microsoft Windows, Red Hat and SUSE Linux, and VMware. For specific OS support, see the *HP Intelligent Provisioning Release Notes* on the HP website (<http://www.hp.com/go/intelligentprovisioning/docs>).

For more information about Intelligent Provisioning software, see the HP website (<http://www.hp.com/go/intelligentprovisioning>). For more information about Intelligent Provisioning drivers, firmware, and SPP, see the HP website (<http://www.hp.com/go/spp/download>).

HP Insight Diagnostics

HP Insight Diagnostics is a proactive server management tool, available in both offline and online versions, that provides diagnostics and troubleshooting capabilities to assist IT administrators who verify server installations, troubleshoot problems, and perform repair validation.

HP Insight Diagnostics Offline Edition performs various in-depth system and component testing while the OS is not running. To run this utility, boot the server using Intelligent Provisioning (on page 100).

HP Insight Diagnostics Online Edition is a web-based application that captures system configuration and other related data needed for effective server management. Available in Microsoft Windows and Linux versions, the utility helps to ensure proper system operation.

For more information or to download the utility, see the HP website (<http://www.hp.com/servers/diags>). HP Insight Diagnostics Online Edition is also available in the SPP. For more information, see the HP website (<http://www.hp.com/go/spp/download>).

HP Insight Diagnostics survey functionality

HP Insight Diagnostics (on page 101) provides survey functionality that gathers critical hardware and software information on ProLiant servers.

This functionality supports operating systems that are supported by the server. For operating systems supported by the server, see the HP website (<http://www.hp.com/go/supportos>).

If a significant change occurs between data-gathering intervals, the survey function marks the previous information and overwrites the survey data files to reflect the latest changes in the configuration.

Survey functionality is installed with every Intelligent Provisioning-assisted HP Insight Diagnostics installation, or it can be installed through the SPP ("HP Service Pack for ProLiant" on page 102).

Erase Utility



CAUTION: Perform a backup before running the System Erase Utility. The utility sets the system to its original factory state, deletes the current hardware configuration information, including array setup and disk partitioning, and erases all connected hard drives completely. Refer to the instructions for using this utility.

Use the Erase Utility to erase hard drives and Active Health System logs, and to reset RBSU settings. Run the Erase Utility if you must erase the system for the following reasons:

- You want to install a new operating system on a server with an existing operating system.
- You encounter an error when completing the steps of a factory-installed operating system installation.

To access the Erase Utility, click the Perform Maintenance icon from the Intelligent Provisioning home screen, and then select **Erase**.

Run the Erase utility to:

- **Do not erase** — does not erase hard drive operations.
- **Reset** — erases the master boot record for the hard drives so they are no longer bootable.
- **Secure erase** — performs an overwrite pattern erase so no data is recoverable.

After selecting the appropriate option, click **Erase Selected**. A Confirm Erase window is displayed, prompting you to confirm or cancel the Erase.

HP Insight Remote Support software

HP strongly recommends that you install HP Insight Remote Support software to complete the installation or upgrade of your product and to enable enhanced delivery of your HP Warranty, HP Care Pack Service, or HP contractual support agreement. HP Insight Remote Support supplements your monitoring continuously to ensure maximum system availability by providing intelligent event diagnosis, and automatic, secure submission of hardware event notifications to HP, which will initiate a fast and accurate resolution, based on your product's service level. Notifications may be sent to your authorized HP Channel Partner for onsite service, if configured and available in your country.

The HP Insight Remote Support software extends the HP enterprise remote support portfolio for customers with small and medium size IT environments. The software is available in two variants:

- **HP Insight Remote Support 7.x software** is optimized to support up to 500 managed systems and can be installed on a Windows ProLiant hosting device or a Windows ESXi Virtual Machine. It can be integrated easily to work with a supported version of HP Systems Insight Manager. HP Insight Remote Support 7.x provides anytime, anywhere personalized access to your IT environment through HP Insight Online, and is also the recommended version for HP Proactive Care Service.
- **HP Insight Remote Support Advanced** supports medium-sized to large environments with up to 3,500 devices. It can be installed on a Windows ProLiant hosting device or a Windows ESXi Virtual Machine and requires HP Systems Insight Manager. Optionally, customers using HP Operations Manager or SAP Solution Manager to manage their environment can integrate these platforms easily to create a single view. This software is also optimized to deliver Mission Critical Services through additional features.

For more information about the Insight Remote Support Advanced software, see the HP website (<http://www.hp.com/go/insightremotesupport>).

The *HP Insight Remote Support Release Notes* detail the prerequisites, supported hardware, and associated operating systems. The release notes are available on the HP website (<http://www.hp.com/go/insightremotesupport/docs>). HP Insight Remote Support is included as part of HP Warranty, HP Care Pack Service, or HP contractual support agreement.

Scripting Toolkit

The Scripting Toolkit is a server deployment product that enables you to build an unattended automated installation for high-volume server deployments. The Scripting Toolkit is designed to support ProLiant BL, ML, DL, and SL servers. The toolkit includes a modular set of utilities and important documentation that describes how to apply these tools to build an automated server deployment process.

The Scripting Toolkit provides a flexible way to create standard server configuration scripts. These scripts are used to automate many of the manual steps in the server configuration process. This automated server configuration process cuts time from each deployment, making it possible to scale rapid, high-volume server deployments.

For more information, and to download the Scripting Toolkit, see the HP website (<http://www.hp.com/go/ProLiantSTK>).

HP Service Pack for ProLiant

SPP is a release set that contains a comprehensive collection of firmware and system software components, all tested together as a single solution stack for HP ProLiant servers, their options, BladeSystem enclosures, and limited HP external storage.

SPP has several key features for updating HP ProLiant servers. Using HP SUM as the deployment tool, SPP can be used in an online mode on a Windows or Linux hosted operating system, or in an offline mode where the server is booted to the ISO so that the server can be updated automatically with no user interaction or updated in interactive mode.

For more information or to download SPP, see the HP website (<http://www.hp.com/go/spp>).

HP Smart Update Manager

HP SUM is included in many HP products for installing and updating firmware and software on HP ProLiant servers. HP SUM provides a GUI and a command-line scriptable interface for deployment of firmware and software for single or one-to-many HP ProLiant servers and network-based targets, such as iLOs, OAs, and VC Ethernet and Fibre Channel modules.

Key features of HP SUM include:

- Dependency checking, which ensures appropriate installation order and dependency checking between components
- Intelligent deployment of only required updates
- Simultaneous firmware and software deployment for multiple remote targets in both GUI and CLI modes
- Improved deployment performance
- Local online deployment of HP ProLiant servers and enclosures
- Remote (one-to-many) online deployment of HP ProLiant servers and enclosures
- Local offline firmware deployments with HP Support Pack for ProLiant deliverables
- Remote offline deployment when used with the Scripting Toolkit (HP ProLiant Gen8 and later), iLO Virtual Media, or PXE booted media
- GUI or CLI scripts with extensive logging
- Remote command-line deployment
- Support for updating firmware on network-based targets such as the OA, iLO through the Network Management Port, VC Ethernet and Fibre Channel modules, and 3Gb/6Gb SAS BL Switch interconnects on HP ProLiant servers

For more information about HP SUM and to access the *HP Smart Update Manager User Guide*, see the HP website (<http://www.hp.com/go/hpsum/documentation>).

HP ROM-Based Setup Utility

RBSU is a configuration utility embedded in HP ProLiant servers that performs a wide range of configuration activities that can include the following:

- Configuring system devices and installed options
- Enabling and disabling system features
- Displaying system information
- Selecting the primary boot controller
- Configuring memory options
- Language selection

For more information on RBSU, see the *HP ROM-Based Setup Utility User Guide* on the Documentation CD or the HP website (<http://www.hp.com/support/rbsu>).

Using RBSU

To use RBSU, use the following keys:

- To access RBSU, press the **F9** key during power-up when prompted.
- To navigate the menu system, use the arrow keys.
- To make selections, press the **Enter** key.
- To access Help for a highlighted configuration option, press the **F1** key.



IMPORTANT: RBSU automatically saves settings when you press the **Enter** key. The utility does not prompt you for confirmation of settings before you exit the utility. To change a selected setting, you must select a different setting and press the **Enter** key.

Default configuration settings are applied to the server at one of the following times:

- Upon the first system power-up
- After defaults have been restored

Default configuration settings are sufficient for proper typical server operation, but configuration settings can be modified using RBSU. The system will prompt you for access to RBSU with each power-up.

Auto-configuration process

The auto-configuration process automatically runs when you boot the server for the first time. During the power-up sequence, the system ROM automatically configures the entire system without needing any intervention. During this process, the ORCA utility, in most cases, automatically configures the array to a default setting based on the number of drives connected to the server.

NOTE: If the boot drive is not empty or has been written to in the past, ORCA does not automatically configure the array. You must run ORCA to configure the array settings.

NOTE: The server may not support all the following examples.

Drives installed	Drives used	RAID level
1	1	RAID 0
2	2	RAID 1
3, 4, 5, or 6	3, 4, 5, or 6	RAID 5
More than 6	0	None

To change any ORCA default settings and override the auto-configuration process, press the **F8** key when prompted.

For more information on RBSU, see the *HP ROM-Based Setup Utility User Guide* on the Documentation CD or the HP website (<http://www.hp.com/support/rbsu>).

Boot options

Near the end of the boot process, the boot options screen is displayed. This screen is visible for several seconds before the system attempts to boot from a supported boot device. During this time, you can do the following:

- Access RBSU by pressing the **F9** key.
- Access Intelligent Provisioning Maintenance Menu by pressing the **F10** key.
- Access the boot menu by pressing the **F11** key.
- Force a PXE Network boot by pressing the **F12** key.

Configuring AMP modes

Not all HP ProLiant servers support all AMP modes. RBSU provides menu options only for the modes supported by the server. Advanced memory protection within RBSU enables the following advanced memory modes:

- **Advanced ECC Mode**—Provides memory protection beyond Standard ECC. All single-bit failures and some multi-bit failures can be corrected without resulting in system downtime.
- **Online Spare Mode**—Provides protection against failing or degraded DIMMs. Certain memory is set aside as spare, and automatic failover to spare memory occurs when the system detects a degraded DIMM. DIMMs that are likely to receive a fatal or uncorrectable memory error are removed from operation automatically, resulting in less system downtime.

For DIMM population requirements, see the server-specific user guide.

Re-entering the server serial number and product ID

After you replace the system board, you must re-enter the server serial number and the product ID.

1. During the server startup sequence, press the **F9** key to access RBSU.
2. Select the **Advanced Options** menu.
3. Select **Service Options**.
4. Select **Serial Number**. The following warnings appear:

```
WARNING! WARNING! WARNING! The serial number is loaded into the system during
the manufacturing process and should NOT be modified. This option should only
be used by qualified service personnel. This value should always match the
serial number sticker located on the chassis.
```



```
Warning: The serial number should ONLY be modified by qualified service
personnel. This value should always match the serial number located on the
chassis.
```
5. Press the **Enter** key to clear the warning.
6. Enter the serial number and press the **Enter** key.
7. Select **Product ID**. The following warning appears:

```
Warning: The Product ID should ONLY be modified by qualified service
personnel. This value should always match the Product ID on the chassis.
```
8. Enter the product ID and press the **Enter** key.
9. Press the **Esc** key to close the menu.

10. Press the **Esc** key to exit RBSU.
11. Press the **F10** key to confirm exiting RBSU. The server automatically reboots.

Utilities and features

Array Configuration Utility

ACU is a utility with the following features:

- Runs as a local application or remote service accessed through the HP System Management Homepage
- Supports online array capacity expansion, logical drive extension, assignment of online spares, and RAID or stripe size migration
- Suggests the optimum configuration for an unconfigured system
- For supported controllers, provides access to licensed features, including:
 - Moving and deleting individual logical volumes
 - Advanced Capacity Expansion (SATA to SAS and SAS to SATA)
 - Offline Split Mirror
 - RAID 6 and RAID 60
 - RAID 1 (ADM) and RAID 10 (ADM)
 - HP Drive Erase
 - Video-On-Demand Advanced Controller Settings
- Provides different operating modes, enabling faster configuration or greater control over the configuration options
- Remains available any time that the server is on
- Displays on-screen tips for individual steps of a configuration procedure
- Provides context-sensitive searchable help content
- Provides diagnostic and SmartSSD Wear Gauge functionality on the Diagnostics tab

ACU is now available as an embedded utility, starting with HP ProLiant Gen8 servers. To access ACU, use one of the following methods:

- If an optional controller is not installed, press **F10** during boot.
- If an optional controller is installed, when the system recognizes the controller during POST, press **F5**.

For optimum performance, the minimum display settings are 1024 × 768 resolution and 16-bit color. Servers running Microsoft® operating systems require one of the following supported browsers:

- Internet Explorer 6.0 or later
- Mozilla Firefox 2.0 or later

For Linux servers, see the README.TXT file for additional browser and support information.

For more information about the controller and its features, see the *HP Smart Array Controllers for HP ProLiant Servers User Guide* on the HP website (http://www.hp.com/support/SAC_UG_ProLiantServers_en). To configure arrays, see the *Configuring Arrays on HP Smart Array Controllers Reference Guide* on the HP website (http://www.hp.com/support/CASAC_RG_en).

Option ROM Configuration for Arrays

Before installing an operating system, you can use the ORCA utility to create the first logical drive, assign RAID levels, and establish online spare configurations.

The utility also provides support for the following functions:

- Reconfiguring one or more logical drives
- Viewing the current logical drive configuration
- Deleting a logical drive configuration
- Setting the controller to be the boot controller
- Selecting the boot volume

If you do not use the utility, ORCA will default to the standard configuration.

For more information regarding the default configurations that ORCA uses, see the *HP ROM-Based Setup Utility User Guide* on the Documentation CD or the HP website (<http://www.hp.com/support/rbsu>).

For more information about the controller and its features, see the *HP Smart Array Controllers for HP ProLiant Servers User Guide* on the HP website (http://www.hp.com/support/SAC_UG_ProLiantServers_en). To configure arrays, see the *Configuring Arrays on HP Smart Array Controllers Reference Guide* on the HP website (http://www.hp.com/support/CASAC_RG_en).

ROMPaq utility

The ROMPaq utility enables you to upgrade the system firmware (BIOS). To upgrade the firmware, insert a ROMPaq USB Key into an available USB port and boot the system. In addition to ROMPaq, Online Flash Components for Windows and Linux operating systems are available for updating the system firmware.

The ROMPaq utility checks the system and provides a choice (if more than one exists) of available firmware revisions.

For more information, go to the HP website (<http://www.hp.com/go/hpsc>) and click on **Drivers, Software & Firmware**. Then, enter your product name in the **Find an HP product** field and click **Go**.

Automatic Server Recovery

ASR is a feature that causes the system to restart when a catastrophic operating system error occurs, such as a blue screen, ABEND (does not apply to HP ProLiant DL980 Servers), or panic. A system fail-safe timer, the ASR timer, starts when the System Management driver, also known as the Health Driver, is loaded. When the operating system is functioning properly, the system periodically resets the timer. However, when the operating system fails, the timer expires and restarts the server.

ASR increases server availability by restarting the server within a specified time after a system hang. At the same time, the HP SIM console notifies you by sending a message to a designated pager number that ASR has restarted the system. You can disable ASR from the System Management Homepage or through RBSU.

USB support

HP provides both standard USB 2.0 support and legacy USB 2.0 support. Standard support is provided by the OS through the appropriate USB device drivers. Before the OS loads, HP provides support for USB devices through legacy USB support, which is enabled by default in the system ROM.

Legacy USB support provides USB functionality in environments where USB support is not available normally. Specifically, HP provides legacy USB functionality for the following:

- POST
- RBSU
- Diagnostics
- DOS
- Operating environments which do not provide native USB support

Redundant ROM support

The server enables you to upgrade or configure the ROM safely with redundant ROM support. The server has a single ROM that acts as two separate ROM images. In the standard implementation, one side of the ROM contains the current ROM program version, while the other side of the ROM contains a backup version.

NOTE: The server ships with the same version programmed on each side of the ROM.

Safety and security benefits

When you flash the system ROM, ROMPaq writes over the backup ROM and saves the current ROM as a backup, enabling you to switch easily to the alternate ROM version if the new ROM becomes corrupted for any reason. This feature protects the existing ROM version, even if you experience a power failure while flashing the ROM.

Keeping the system current

Drivers



IMPORTANT: Always perform a backup before installing or updating device drivers.

The server includes new hardware that may not have driver support on all OS installation media.

If you are installing an Intelligent Provisioning-supported OS, use Intelligent Provisioning (on page 100) and its Configure and Install feature to install the OS and latest supported drivers.

If you do not use Intelligent Provisioning to install an OS, drivers for some of the new hardware are required. These drivers, as well as other option drivers, ROM images, and value-add software can be downloaded as part of an SPP.

If you are installing drivers from SPP, be sure that you are using the latest SPP version that your server supports. To verify that your server is using the latest supported version and for more information about SPP, see the HP website (<http://www.hp.com/go/spp/download>).

To locate the drivers for a particular server, go to the HP website (<http://www.hp.com/go/hpsc>) and click on **Drivers, Software & Firmware**. Then, enter your product name in the **Find an HP product** field and click **Go**.

Software and firmware

Software and firmware should be updated before using the server for the first time, unless any installed software or components require an older version. For system software and firmware updates, download the SPP ("HP Service Pack for ProLiant" on page 102) from the HP website (<http://www.hp.com/go/spp>).

Version control

The VCRM and VCA are web-enabled Insight Management Agents tools that HP SIM uses to schedule software update tasks to the entire enterprise.

- VCRM manages the repository for SPP. Administrators can view the SPP contents or configure VCRM to automatically update the repository with internet downloads of the latest software and firmware from HP.
- VCA compares installed software versions on the node with updates available in the VCRM managed repository. Administrators configure VCA to point to a repository managed by VCRM.

For more information about version control tools, see the *HP Systems Insight Manager User Guide*, the *HP Version Control Agent User Guide*, and the *HP Version Control Repository User Guide* on the HP website (<http://www.hp.com/go/hpsim>).

HP operating systems and virtualization software support for ProLiant servers

For information about specific versions of a supported operating system, see the HP website (<http://www.hp.com/go/ossupport>).

HP Technology Service Portfolio

HP Technology Services offers a targeted set of consultancy, deployment, and service solutions designed to meet the support needs of the most business and IT environments.

Foundation Care services deliver scalable hardware and software support packages for HP ProLiant server and industry-standard software. You can choose the type and level of service that is most suitable for your business needs.

HP Collaborative Support — With a single call, HP addresses initial hardware and software support needs and helps to quickly identify if a problem is related to hardware or software. If the problem is identified as hardware, HP will resolve as per service level commitments. If the reported incident is related to HP or supported 3rd party software product and cannot be resolved by applying known fixes, HP will contact the third-party vendor and create a problem incident on the your behalf.

HP Proactive Care — For customers running business critical environments where down time is not an option, then HP Proactive Care helps to deliver high levels of application availability. Key to these service options is the delivery of proactive service management offers to help you avoid the causes of down time. If a problems arises than HP offers advanced technical response from critical system support specialist for fast problem identification and resolution.

HP Support Center — All service options include HP Support Center delivering information, tools, and experts required to support HP business products.

HP Insight Remote Support — Provides 24x7 secure remote monitoring, diagnosis and problem resolution.

For more information, see the HP website (<http://www.hp.com/services/proliant>) or the HP website for the HP BladeSystem (<http://www.hp.com/services/bladeSystem>).

Change control and proactive notification

HP offers Change Control and Proactive Notification to notify customers 30 to 60 days in advance of upcoming hardware and software changes on HP commercial products.

For more information, refer to the HP website (<http://www.hp.com/go/pcn>).

Troubleshooting

Troubleshooting resources

The *HP ProLiant Gen8 Troubleshooting Guide, Volume I: Troubleshooting* provides procedures for resolving common problems and comprehensive courses of action for fault isolation and identification, issue resolution, and software maintenance on ProLiant servers and server blades. To view the guide, select a language:

- English (http://www.hp.com/support/ProLiant_TSG_v1_en)
- French (http://www.hp.com/support/ProLiant_TSG_v1_fr)
- Spanish (http://www.hp.com/support/ProLiant_TSG_v1_sp)
- German (http://www.hp.com/support/ProLiant_TSG_v1_gr)
- Japanese (http://www.hp.com/support/ProLiant_TSG_v1_jp)
- Simplified Chinese (http://www.hp.com/support/ProLiant_TSG_v1_sc)

The *HP ProLiant Gen8 Troubleshooting Guide, Volume II: Error Messages* provides a list of error messages and information to assist with interpreting and resolving error messages on ProLiant servers and server blades. To view the guide, select a language:

- English (http://www.hp.com/support/ProLiant_EMG_v1_en)
- French (http://www.hp.com/support/ProLiant_EMG_v1_fr)
- Spanish (http://www.hp.com/support/ProLiant_EMG_v1_sp)
- German (http://www.hp.com/support/ProLiant_EMG_v1_gr)
- Japanese (http://www.hp.com/support/ProLiant_EMG_v1_jp)
- Simplified Chinese (http://www.hp.com/support/ProLiant_EMG_v1_sc)

Battery replacement

If the server no longer automatically displays the correct date and time, you may need to replace the battery that provides power to the real-time clock.



WARNING: The computer contains an internal lithium manganese dioxide, a vanadium pentoxide, or an alkaline battery pack. A risk of fire and burns exists if the battery pack is not properly handled. To reduce the risk of personal injury:

- Do not attempt to recharge the battery.
- Do not expose the battery to temperatures higher than 60°C (140°F).
- Do not disassemble, crush, puncture, short external contacts, or dispose of in fire or water.
- Replace only with the spare designated for this product.

To remove the component:

1. Power down the server (on page 23).
2. Remove all power:
 - a. Disconnect each power cord from the power source.
 - b. Disconnect each power cord from the server.
3. Extend ("[Extend the server from the rack](#)" on page 23) or remove ("[Remove the server from the rack](#)" on page 24) the server from the rack.
4. Remove the access panel (on page 25).
5. If installed, remove the secondary PCIe riser cage (on page 30).
6. Locate the battery ("[System board components](#)" on page 15).
7. Remove the battery.

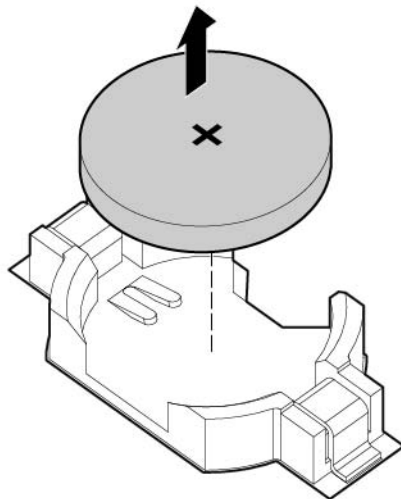

To replace the component, reverse the removal procedure.

For more information about battery replacement or proper disposal, contact an authorized reseller or an authorized service provider.

Regulatory information

Safety and regulatory compliance

For safety, environmental, and regulatory information, see *Safety and Compliance Information for Server, Storage, Power, Networking, and Rack Products*, available at the HP website (<http://www.hp.com/support/Safety-Compliance-EnterpriseProducts>).

Turkey RoHS material content declaration

Türkiye Cumhuriyeti: EEE Yönetmeliğine Uygundur

Ukraine RoHS material content declaration

Обладнання відповідає вимогам Технічного регламенту щодо обмеження використання деяких небезпечних речовин в електричному та електронному обладнанні, затвердженого постановою Кабінету Міністрів України від 3 грудня 2008 № 1057

Warranty information

HP ProLiant and X86 Servers and Options (<http://www.hp.com/support/ProLiantServers-Warranties>)

HP Enterprise Servers (<http://www.hp.com/support/EnterpriseServers-Warranties>)

HP Storage Products (<http://www.hp.com/support/Storage-Warranties>)

HP Networking Products (<http://www.hp.com/support/Networking-Warranties>)

Electrostatic discharge

Preventing electrostatic discharge

To prevent damaging the system, be aware of the precautions you need to follow when setting up the system or handling parts. A discharge of static electricity from a finger or other conductor may damage system boards or other static-sensitive devices. This type of damage may reduce the life expectancy of the device.

To prevent electrostatic damage:

- Avoid hand contact by transporting and storing products in static-safe containers.
- Keep electrostatic-sensitive parts in their containers until they arrive at static-free workstations.
- Place parts on a grounded surface before removing them from their containers.
- Avoid touching pins, leads, or circuitry.
- Always be properly grounded when touching a static-sensitive component or assembly.

Grounding methods to prevent electrostatic discharge

Several methods are used for grounding. Use one or more of the following methods when handling or installing electrostatic-sensitive parts:

- Use a wrist strap connected by a ground cord to a grounded workstation or computer chassis. Wrist straps are flexible straps with a minimum of 1 megohm ± 10 percent resistance in the ground cords. To provide proper ground, wear the strap snug against the skin.
- Use heel straps, toe straps, or boot straps at standing workstations. Wear the straps on both feet when standing on conductive floors or dissipating floor mats.
- Use conductive field service tools.
- Use a portable field service kit with a folding static-dissipating work mat.

If you do not have any of the suggested equipment for proper grounding, have an authorized reseller install the part.

For more information on static electricity or assistance with product installation, contact an authorized reseller.

Specifications

Environmental specifications

Specification	Value
Temperature range*	
Operating	10°C to 35°C (50°F to 95°F)
Shipping	-30°C to 50°C (-22°F to 122°F)
Storage	-30°C to 60°C (-22°F to 140°F)
Maximum wet bulb temperature	28°C (82.4°F)
Relative humidity (noncondensing)**	
Operating	10% to 90%
Non-operating	5% to 95%

* All temperature ratings shown are for sea level. An altitude derating of 1°C per 300 m (1.8°F per 1,000 ft) to 3048 m (10,000 ft) is applicable. No direct sunlight allowed.

** Storage maximum humidity of 95% is based on a maximum temperature of 45°C (113°F). Altitude maximum for storage corresponds to a pressure minimum of 70 KPa.

Mechanical specifications

Specification	Value
Height	8.73 cm (3.44 in)
Depth, SFF	69.85 cm (27.50 in)
Depth, LFF	74.93 cm (29.5 in)
Width	44.55 cm (17.54 in)
Weight, 8 LFF	22.63 kg-30.19 kg (49.9 lb- 66.5 lb)
Weight, 12 LFF	20.02 kg- 32.66 kg (44.1 lb- 72 lb)
Weight, 8 SFF	23.53 kg- 28.08 kg (51.9 lb- 61.9 lb)
Weight, 16 SFF	19.92 kg-27.76 kg (43.9 lb-61.2 lb)
Weight, 25 SFF	21.15 kg-28.37 kg (46.6 lb-62.5 lb)

Power supply specifications

Depending on installed options, the server is configured with one of the following power supplies:

- HP 460 W CS Gold power supply (92% efficiency) (on page [117](#))

- HP 460 W CS Platinum Plus power supply (94% efficiency) (on page 117)
- HP 750 W CS Gold power supply (92% efficiency) (on page 118)
- HP 750 W CS Platinum Plus power supply (94% efficiency) (on page 118)
- HP 750 W 48V CS DC power supply (94% efficiency) (on page 119)
- HP 1200 W CS Platinum Plus power supply (90% efficiency) (on page 119)

For detailed power supply specifications, see the quickspecs on the HP website (http://h18000.www1.hp.com/products/quickspecs/14209_div/14209_div.html).

HP 460 W CS Gold power supply (92% efficiency)

Specification	Value
Input requirements	—
Rated input voltage	100V to 240V AC
Rated input frequency	50 Hz or 60 Hz
Rated input current	5.5A to 2.2A
Rated input power	526 W at 100 V AC input 505 W at 200 V AC input
Btus per hour	1794 at 100 V AC input 1725 at 200 V AC input
Power supply output	—
Rated steady-state power	460 W at 100 V to 120 V AC input 460 W at 200 V to 240 V AC input
Maximum peak power	460 W at 100 V to 120 V AC input 460 W at 200 V to 240 V AC input

HP 460 W CS Platinum Plus power supply (94% efficiency)

Specification	Value
Input requirements	—
Rated input voltage	100V to 240V AC
Rated input frequency	50 Hz or 60 Hz
Rated input current	5.2A to 2.1A
Rated input power	509 W at 115 V AC input 495 W at 230 V AC input
Btus per hour	1764 at 100 V AC 1694 at 200 V AC
Power supply output	—
Rated steady-state power	460 W at 100 V to 120 V AC input 460 W at 200 V to 240 V AC input

Maximum peak power	460 W at 100 V to 120 V AC input 460 W at 200 V to 240 V AC input
--------------------	--

HP 750 W CS Gold power supply (92% efficiency)

Specification	Value
Input requirements	—
Rated input voltage	100V to 240V AC
Rated input frequency	50 to 60 Hz
Rated input current	8.9A to 3.6A
Rated input power	857 W at 100 V AC input 824 W at 200 V AC input
Btus per hour	2925 at 100 V AC input 2812 at 200 V AC input
Power supply output	—
Rated steady-state power	750 W at 100 V to 120 V AC input 750 W at 200 V to 240 V AC input
Maximum peak power	750 W at 100 V to 120 V AC input 750 W at 200 V to 240 V AC input

HP 750 W CS Platinum Plus power supply (94% efficiency)

Specification	Value
Input requirements	—
Rated input voltage	100V to 240V AC
Rated input frequency	50 Hz to 60 Hz
Rated input current	8.5A to 3.5A
Maximum rated input power	831 W at 115 V AC input 808 W at 230 V AC input
Btus per hour	2878 at 100 V AC 2769 at 200 V AC
Power supply output	—
Rated steady-state power	750 W at 100 V to 120 V AC input 750 W at 200 V to 240 V AC input
Maximum peak power	750 W at 100 V to 120 V AC input 750 W at 200 V to 240 V AC input

HP 750 W 48V CS DC power supply (94% efficiency)

Specification	Value
Input requirements	—
Rated input voltage	-36V to -72V DC -48V DC, nominal input
Rated input frequency	DC
Rated input current	2.3A at -36V DC 12A at -72V DC 17A at -48V DC, nominal input
Rated input power	840 W at -36V DC input 830 W at -72V DC input 820 W at -48V DC, nominal input
Btus per hour	2865 at -36V DC input 2830 at -72V DC input 2796 at -48V DC, nominal input
Power supply output	—
Rated steady-state power	750 W
Rated peak power	750 W



CAUTION: This equipment is designed to permit the connection of the earthed conductor of the DC supply circuit to the earthing conductor at the equipment.

If this connection is made, all of the following must be met:

- This equipment must be connected directly to the DC supply system earthing electrode conductor or to a bonding jumper from an earthing terminal bar or bus to which the DC supply system earthing electrode conductor is connected.
- This equipment must be located in the same immediate area (such as adjacent cabinets) as any other equipment that has a connection between the earthed conductor of the same DC supply circuit and the earthing conductor, and also the point of earthing of the DC system. The DC system must be earthed elsewhere.
- The DC supply source is to be located within the same premises as the equipment.
- Switching or disconnecting devices must not be in the earthed circuit conductor between the DC source and the point of connection of the earthing electrode conductor.



CAUTION: To reduce the risk of electric shock or energy hazards:

- This equipment must be installed by trained service personnel, as defined by the NEC and IEC 60950-1, Second Edition, the standard for Safety of Information Technology Equipment.
- Connect the equipment to a reliably grounded SELV source. An SELV source is a secondary circuit that is designed so normal and single fault conditions do not cause the voltages to exceed a safe level (60 V DC).
- The branch circuit overcurrent protection must be rated 24 A.

HP 1200 W CS Platinum Plus Power Supply (90% efficiency)

Specification	Value
Input requirements	—
Rated input voltage	100V AC to 240V AC

Rated input frequency	50 Hz to 60 Hz
Rated input current	9.1A to 5.5A
Maximum rated input power	897 W at 100V AC input 1321 W at 200V AC input
Btus per hour	3061 at 100V AC input 4506 at 200V AC input
Power supply output	—
Rated steady-state power	800 W at 100V AC input 900 W at 120V AC input 1200 W at 200V to 240V AC input
Maximum peak power	800 W at 100V AC input 900 W at 120V AC input 1200 W at 200V to 240V AC input

Support and other resources

Before you contact HP

Be sure to have the following information available before you call HP:

- Active Health System log (HP ProLiant Gen8 or later products)
Download and have available an Active Health System log for 3 days before the failure was detected. For more information, see the *HP iLO 4 User Guide* or *HP Intelligent Provisioning User Guide* on the HP website (<http://www.hp.com/go/ilo/docs>).
- Onboard Administrator SHOW ALL report (for HP BladeSystem products only)
For more information on obtaining the Onboard Administrator SHOW ALL report, see the HP website (<http://h20000.www2.hp.com/bizsupport/TechSupport/Document.jsp?lang=en&cc=us&objectID=c02843807>).
- Technical support registration number (if applicable)
- Product serial number
- Product model name and number
- Product identification number
- Applicable error messages
- Add-on boards or hardware
- Third-party hardware or software
- Operating system type and revision level

HP contact information

For United States and worldwide contact information, see the Contact HP website (<http://www.hp.com/go/assistance>).

In the United States:

- To contact HP by phone, call 1-800-334-5144. For continuous quality improvement, calls may be recorded or monitored.
- If you have purchased a Care Pack (service upgrade), see the Support & Drivers website (<http://www8.hp.com/us/en/support-drivers.html>). If the problem cannot be resolved at the website, call 1-800-633-3600. For more information about Care Packs, see the HP website (<http://pro-aq-sama.houston.hp.com/services/cache/10950-0-0-225-121.html>).

Customer Self Repair

HP products are designed with many Customer Self Repair (CSR) parts to minimize repair time and allow for greater flexibility in performing defective parts replacement. If during the diagnosis period HP (or HP service

providers or service partners) identifies that the repair can be accomplished by the use of a CSR part, HP will ship that part directly to you for replacement. There are two categories of CSR parts:

- **Mandatory**—Parts for which customer self repair is mandatory. If you request HP to replace these parts, you will be charged for the travel and labor costs of this service.
- **Optional**—Parts for which customer self repair is optional. These parts are also designed for customer self repair. If, however, you require that HP replace them for you, there may or may not be additional charges, depending on the type of warranty service designated for your product.

NOTE: Some HP parts are not designed for customer self repair. In order to satisfy the customer warranty, HP requires that an authorized service provider replace the part. These parts are identified as "No" in the Illustrated Parts Catalog.

Based on availability and where geography permits, CSR parts will be shipped for next business day delivery. Same day or four-hour delivery may be offered at an additional charge where geography permits. If assistance is required, you can call the HP Technical Support Center and a technician will help you over the telephone. HP specifies in the materials shipped with a replacement CSR part whether a defective part must be returned to HP. In cases where it is required to return the defective part to HP, you must ship the defective part back to HP within a defined period of time, normally five (5) business days. The defective part must be returned with the associated documentation in the provided shipping material. Failure to return the defective part may result in HP billing you for the replacement. With a customer self repair, HP will pay all shipping and part return costs and determine the courier/carrier to be used.

For more information about HP's Customer Self Repair program, contact your local service provider. For the North American program, refer to the HP website (<http://www.hp.com/go/selfrepair>).

Réparation par le client (CSR)

Les produits HP comportent de nombreuses pièces CSR (Customer Self Repair = réparation par le client) afin de minimiser les délais de réparation et faciliter le remplacement des pièces défectueuses. Si pendant la période de diagnostic, HP (ou ses partenaires ou mainteneurs agréés) détermine que la réparation peut être effectuée à l'aide d'une pièce CSR, HP vous l'envoie directement. Il existe deux catégories de pièces CSR:

Obligatoire - Pièces pour lesquelles la réparation par le client est obligatoire. Si vous demandez à HP de remplacer ces pièces, les coûts de déplacement et main d'œuvre du service vous seront facturés.

Facultatif - Pièces pour lesquelles la réparation par le client est facultative. Ces pièces sont également conçues pour permettre au client d'effectuer lui-même la réparation. Toutefois, si vous demandez à HP de remplacer ces pièces, l'intervention peut ou non vous être facturée, selon le type de garantie applicable à votre produit.

REMARQUE: Certaines pièces HP ne sont pas conçues pour permettre au client d'effectuer lui-même la réparation. Pour que la garantie puisse s'appliquer, HP exige que le remplacement de la pièce soit effectué par un Mainteneur Agréé. Ces pièces sont identifiées par la mention "Non" dans le Catalogue illustré.

Les pièces CSR sont livrées le jour ouvré suivant, dans la limite des stocks disponibles et selon votre situation géographique. Si votre situation géographique le permet et que vous demandez une livraison le jour même ou dans les 4 heures, celle-ci vous sera facturée. Pour bénéficier d'une assistance téléphonique, appelez le Centre d'assistance technique HP. Dans les documents envoyés avec la pièce de rechange CSR, HP précise s'il est nécessaire de lui retourner la pièce défectueuse. Si c'est le cas, vous devez le faire dans le délai indiqué, généralement cinq (5) jours ouvrés. La pièce et sa documentation doivent être retournées dans l'emballage fourni. Si vous ne retournez pas la pièce défectueuse, HP se réserve le droit de vous facturer les coûts de remplacement. Dans le cas d'une pièce CSR, HP supporte l'ensemble des frais d'expédition et de retour, et détermine la société de courses ou le transporteur à utiliser.

Pour plus d'informations sur le programme CSR de HP, contactez votre Mainteneur Agréé local. Pour plus d'informations sur ce programme en Amérique du Nord, consultez le site Web HP (<http://www.hp.com/go/selfrepair>).

Riparazione da parte del cliente

Per abbreviare i tempi di riparazione e garantire una maggiore flessibilità nella sostituzione di parti difettose, i prodotti HP sono realizzati con numerosi componenti che possono essere riparati direttamente dal cliente (CSR, Customer Self Repair). Se in fase di diagnostica HP (o un centro di servizi o di assistenza HP) identifica il guasto come riparabile mediante un ricambio CSR, HP lo spedisce direttamente al cliente per la sostituzione. Vi sono due categorie di parti CSR:

Obbligatorie – Parti che devono essere necessariamente riparate dal cliente. Se il cliente ne affida la riparazione ad HP, deve sostenere le spese di spedizione e di manodopera per il servizio.

Opzionali – Parti la cui riparazione da parte del cliente è facoltativa. Si tratta comunque di componenti progettati per questo scopo. Se tuttavia il cliente ne richiede la sostituzione ad HP, potrebbe dover sostenere spese aggiuntive a seconda del tipo di garanzia previsto per il prodotto.

NOTA: alcuni componenti HP non sono progettati per la riparazione da parte del cliente. Per rispettare la garanzia, HP richiede che queste parti siano sostituite da un centro di assistenza autorizzato. Tali parti sono identificate da un "No" nel Catalogo illustrato dei componenti.

In base alla disponibilità e alla località geografica, le parti CSR vengono spedite con consegna entro il giorno lavorativo seguente. La consegna nel giorno stesso o entro quattro ore è offerta con un supplemento di costo solo in alcune zone. In caso di necessità si può richiedere l'assistenza telefonica di un addetto del centro di supporto tecnico HP. Nel materiale fornito con una parte di ricambio CSR, HP specifica se il cliente deve restituire dei componenti. Qualora sia richiesta la resa ad HP del componente difettoso, lo si deve spedire ad HP entro un determinato periodo di tempo, generalmente cinque (5) giorni lavorativi. Il componente difettoso deve essere restituito con la documentazione associata nell'imballo di spedizione fornito. La mancata restituzione del componente può comportare la fatturazione del ricambio da parte di HP. Nel caso di riparazione da parte del cliente, HP sostiene tutte le spese di spedizione e resa e sceglie il corriere/vettore da utilizzare.

Per ulteriori informazioni sul programma CSR di HP contattare il centro di assistenza di zona. Per il programma in Nord America fare riferimento al sito Web HP (<http://www.hp.com/go/selfrepair>).

Customer Self Repair

HP Produkte enthalten viele CSR-Teile (Customer Self Repair), um Reparaturzeiten zu minimieren und höhere Flexibilität beim Austausch defekter Bauteile zu ermöglichen. Wenn HP (oder ein HP Servicepartner) bei der Diagnose feststellt, dass das Produkt mithilfe eines CSR-Teils repariert werden kann, sendet Ihnen HP dieses Bauteil zum Austausch direkt zu. CSR-Teile werden in zwei Kategorien unterteilt:

Zwingend – Teile, für die das Customer Self Repair-Verfahren zwingend vorgegeben ist. Wenn Sie den Austausch dieser Teile von HP vornehmen lassen, werden Ihnen die Anfahrt- und Arbeitskosten für diesen Service berechnet.

Optional – Teile, für die das Customer Self Repair-Verfahren optional ist. Diese Teile sind auch für Customer Self Repair ausgelegt. Wenn Sie jedoch den Austausch dieser Teile von HP vornehmen lassen möchten, können bei diesem Service je nach den für Ihr Produkt vorgesehenen Garantiebedingungen zusätzliche Kosten anfallen.

HINWEIS: Einige Teile sind nicht für Customer Self Repair ausgelegt. Um den Garantieanspruch des Kunden zu erfüllen, muss das Teil von einem HP Servicepartner ersetzt werden. Im illustrierten Teilekatalog sind diese Teile mit „No“ bzw. „Nein“ gekennzeichnet.

CSR-Teile werden abhängig von der Verfügbarkeit und vom Lieferziel am folgenden Geschäftstag geliefert. Für bestimmte Standorte ist eine Lieferung am selben Tag oder innerhalb von vier Stunden gegen einen Aufpreis verfügbar. Wenn Sie Hilfe benötigen, können Sie das HP technische Support Center anrufen und sich von einem Mitarbeiter per Telefon helfen lassen. Den Materialien, die mit einem CSR-Ersatzteil geliefert werden, können Sie entnehmen, ob das defekte Teil an HP zurückgeschickt werden muss. Wenn es erforderlich ist, das defekte Teil an HP zurückzuschicken, müssen Sie dies innerhalb eines vorgegebenen Zeitraums tun, in der Regel innerhalb von fünf (5) Geschäftstagen. Das defekte Teil muss mit der zugehörigen Dokumentation in der Verpackung zurückgeschickt werden, die im Lieferumfang enthalten ist. Wenn Sie das defekte Teil nicht zurückschicken, kann HP Ihnen das Ersatzteil in Rechnung stellen. Im Falle von Customer Self Repair kommt HP für alle Kosten für die Lieferung und Rücksendung auf und bestimmt den Kurier-/Frachtdienst.

Weitere Informationen über das HP Customer Self Repair Programm erhalten Sie von Ihrem Servicepartner vor Ort. Informationen über das CSR-Programm in Nordamerika finden Sie auf der HP Website unter (<http://www.hp.com/go/selfrepair>).

Reparaciones del propio cliente

Los productos de HP incluyen muchos componentes que el propio usuario puede reemplazar (*Customer Self Repair*, CSR) para minimizar el tiempo de reparación y ofrecer una mayor flexibilidad a la hora de realizar sustituciones de componentes defectuosos. Si, durante la fase de diagnóstico, HP (o los proveedores o socios de servicio de HP) identifica que una reparación puede llevarse a cabo mediante el uso de un componente CSR, HP le enviará dicho componente directamente para que realice su sustitución. Los componentes CSR se clasifican en dos categorías:

- **Obligatorio:** componentes para los que la reparación por parte del usuario es obligatoria. Si solicita a HP que realice la sustitución de estos componentes, tendrá que hacerse cargo de los gastos de desplazamiento y de mano de obra de dicho servicio.
- **Opcional:** componentes para los que la reparación por parte del usuario es opcional. Estos componentes también están diseñados para que puedan ser reparados por el usuario. Sin embargo, si precisa que HP realice su sustitución, puede o no conllevar costes adicionales, dependiendo del tipo de servicio de garantía correspondiente al producto.

NOTA: Algunos componentes no están diseñados para que puedan ser reparados por el usuario. Para que el usuario haga valer su garantía, HP pone como condición que un proveedor de servicios autorizado realice la sustitución de estos componentes. Dichos componentes se identifican con la palabra "No" en el catálogo ilustrado de componentes.

Según la disponibilidad y la situación geográfica, los componentes CSR se enviarán para que lleguen a su destino al siguiente día laborable. Si la situación geográfica lo permite, se puede solicitar la entrega en el mismo día o en cuatro horas con un coste adicional. Si precisa asistencia técnica, puede llamar al Centro de asistencia técnica de HP y recibirá ayuda telefónica por parte de un técnico. Con el envío de materiales para la sustitución de componentes CSR, HP especificará si los componentes defectuosos deberán devolverse a HP. En aquellos casos en los que sea necesario devolver algún componente a HP, deberá hacerlo en el periodo de tiempo especificado, normalmente cinco días laborables. Los componentes defectuosos deberán devolverse con toda la documentación relacionada y con el embalaje de envío. Si no enviara el componente defectuoso requerido, HP podrá cobrarle por el de sustitución. En el caso de todas

sustituciones que lleve a cabo el cliente, HP se hará cargo de todos los gastos de envío y devolución de componentes y escogerá la empresa de transporte que se utilice para dicho servicio.

Para obtener más información acerca del programa de Reparaciones del propio cliente de HP, póngase en contacto con su proveedor de servicios local. Si está interesado en el programa para Norteamérica, visite la página web de HP siguiente (<http://www.hp.com/go/selfrepair>).

Customer Self Repair

Veel onderdelen in HP producten zijn door de klant zelf te repareren, waardoor de reparatieduur tot een minimum beperkt kan blijven en de flexibiliteit in het vervangen van defecte onderdelen groter is. Deze onderdelen worden CSR-onderdelen (Customer Self Repair) genoemd. Als HP (of een HP Service Partner) bij de diagnose vaststelt dat de reparatie kan worden uitgevoerd met een CSR-onderdeel, verzendt HP dat onderdeel rechtstreeks naar u, zodat u het defecte onderdeel daarmee kunt vervangen. Er zijn twee categorieën CSR-onderdelen:

Verplicht: Onderdelen waarvoor reparatie door de klant verplicht is. Als u HP verzoekt deze onderdelen voor u te vervangen, worden u voor deze service reiskosten en arbeidsloon in rekening gebracht.

Optioneel: Onderdelen waarvoor reparatie door de klant optioneel is. Ook deze onderdelen zijn ontworpen voor reparatie door de klant. Als u echter HP verzoekt deze onderdelen voor u te vervangen, kunnen daarvoor extra kosten in rekening worden gebracht, afhankelijk van het type garantieservice voor het product.

OPMERKING: Sommige HP onderdelen zijn niet ontwikkeld voor reparatie door de klant. In verband met de garantievoorwaarden moet het onderdeel door een geautoriseerde Service Partner worden vervangen. Deze onderdelen worden in de geïllustreerde onderdelencatalogus aangemerkt met "Nee".

Afhankelijk van de leverbaarheid en de locatie worden CSR-onderdelen verzonden voor levering op de eerstvolgende werkdag. Levering op dezelfde dag of binnen vier uur kan tegen meerkosten worden aangeboden, indien dit mogelijk is gezien de locatie. Indien assistentie gewenst is, belt u een HP Service Partner om via de telefoon technische ondersteuning te ontvangen. HP vermeldt in de documentatie bij het vervangende CSR-onderdeel of het defecte onderdeel aan HP moet worden geretourneerd. Als het defecte onderdeel aan HP moet worden teruggezonden, moet u het defecte onderdeel binnen een bepaalde periode, gewoonlijk vijf (5) werkdagen, retourneren aan HP. Het defecte onderdeel moet met de bijbehorende documentatie worden geretourneerd in het meegeleverde verpakkingsmateriaal. Als u het defecte onderdeel niet terugzendt, kan HP u voor het vervangende onderdeel kosten in rekening brengen. Bij reparatie door de klant betaalt HP alle verzendkosten voor het vervangende en geretourneerde onderdeel en kiest HP zelf welke koerier/transportonderneming hiervoor wordt gebruikt.

Neem contact op met een Service Partner voor meer informatie over het Customer Self Repair programma van HP. Informatie over Service Partners vindt u op de HP website (<http://www.hp.com/go/selfrepair>).

Reparo feito pelo cliente

Os produtos da HP são projetados com muitas peças para reparo feito pelo cliente (CSR) de modo a minimizar o tempo de reparo e permitir maior flexibilidade na substituição de peças com defeito. Se, durante o período de diagnóstico, a HP (ou fornecedores/parceiros de serviço da HP) concluir que o reparo pode ser efetuado pelo uso de uma peça CSR, a peça de reposição será enviada diretamente ao cliente. Existem duas categorias de peças CSR:

Obrigatória – Peças cujo reparo feito pelo cliente é obrigatório. Se desejar que a HP substitua essas peças, serão cobradas as despesas de transporte e mão-de-obra do serviço.

Opcional – Peças cujo reparo feito pelo cliente é opcional. Essas peças também são projetadas para o reparo feito pelo cliente. No entanto, se desejar que a HP as substitua, pode haver ou não a cobrança de taxa adicional, dependendo do tipo de serviço de garantia destinado ao produto.

OBSERVAÇÃO: Algumas peças da HP não são projetadas para o reparo feito pelo cliente. A fim de cumprir a garantia do cliente, a HP exige que um técnico autorizado substitua a peça. Essas peças estão identificadas com a marca "No" (Não), no catálogo de peças ilustrado.

Conforme a disponibilidade e o local geográfico, as peças CSR serão enviadas no primeiro dia útil após o pedido. Onde as condições geográficas permitirem, a entrega no mesmo dia ou em quatro horas pode ser feita mediante uma taxa adicional. Se precisar de auxílio, entre em contato com o Centro de suporte técnico da HP para que um técnico o ajude por telefone. A HP especifica nos materiais fornecidos com a peça CSR de reposição se a peça com defeito deve ser devolvida à HP. Nos casos em que isso for necessário, é preciso enviar a peça com defeito à HP dentro do período determinado, normalmente cinco (5) dias úteis. A peça com defeito deve ser enviada com a documentação correspondente no material de transporte fornecido. Caso não o faça, a HP poderá cobrar a reposição. Para as peças de reparo feito pelo cliente, a HP paga todas as despesas de transporte e de devolução da peça e determina a transportadora/serviço postal a ser utilizado.

Para obter mais informações sobre o programa de reparo feito pelo cliente da HP, entre em contato com o fornecedor de serviços local. Para o programa norte-americano, visite o site da HP (<http://www.hp.com/go/selfrepair>).

カスタマーセルフリペア

修理時間を短縮し、故障部品の交換における高い柔軟性を確保するために、HP製品には多数のCSR部品があります。診断の際に、CSR部品を使用すれば修理ができるとHP（HPまたはHP正規保守代理店）が判断した場合、HPはその部品を直接、お客様に発送し、お客様に交換していただきます。CSR部品には以下の2通りがあります。

- **必須** - カスタマーセルフリペアが必須の部品。当該部品について、もしもお客様がHPに交換作業を依頼される場合には、その修理サービスに関する交通費および人件費がお客様に請求されます。
- **任意** - カスタマーセルフリペアが任意である部品。この部品もカスタマーセルフリペア用です。当該部品について、もしもお客様がHPに交換作業を依頼される場合には、お買い上げの製品に適用される保証サービス内容の範囲内においては、別途費用を負担していただくことなく保証サービスを受けることができます。

注： HP製品の一部の部品は、カスタマーセルフリペア用ではありません。製品の保証を継続するためには、HPまたはHP正規保守代理店による交換作業が必須となります。部品カタログには、当該部品がカスタマーセルフリペア除外品である旨が記載されています。

部品供給が可能な場合、地域によっては、CSR部品を翌営業日に届くように発送します。また、地域によっては、追加費用を負担いただくことにより同日または4時間以内に届くように発送することも可能な場合があります。サポートが必要なときは、HPの修理受付窓口にご連絡いただければ、技術者が電話でアドバイスします。交換用のCSR部品または同梱物には、故障部品をHPに返送する必要があるかどうかが表示されています。故障部品をHPに返送する必要がある場合は、指定期限内（通常は5営業日以内）に故障部品をHPに返送してください。故障部品を返送する場合は、届いた時の梱包箱に関連書類とともにに入れてください。故障部品を返送しない場合、HPから部品費用が請求されます。カスタマーセルフリペアの際には、HPは送料および部品返送費を全額負担し、使用する宅配便会社や運送会社を指定します。

客戶自行維修

HP 產品提供許多客戶自行維修 (CSR) 部件，以尽可能縮短維修時間和在更換缺陷部件方面提供更大的靈活性。如果在診斷期間 HP (或 HP 服務提供商或服務合作夥伴) 確定可以通過使用 CSR 部件完成維修，HP 將直接把該部件發送給您進行更換。有兩類 CSR 部件：

- **強制性的** — 要求客戶必須自行維修的部件。如果您請求 HP 更換這些部件，則必須為該服務支付差旅費和人工費用。
- **可選的** — 客戶可以選擇是否自行維修的部件。這些部件也是為客戶自行維修設計的。不過，如果您要求 HP 為您更換這些部件，則根據為您的產品指定的保修服務類型，HP 可能收取或不再收取任何附加費用。

注：某些 HP 部件的設計並未考慮客戶自行維修。為了滿足客戶保修的需要，HP 要求授權服務提供商更換相關部件。這些部件在部件圖解目錄中標記為“否”。

CSR 部件將在下一個工作日發運（取決於備貨情況和允許的地理範圍）。在允許的地理範圍內，可在當天或四小時內發運，但要收取額外費用。如果需要幫助，您可以致電 HP 技術支持中心，將會有技術人員通過電話為您提供幫助。HP 會在隨更換的 CSR 部件發運的材料中指明是否必須將有缺陷的部件返還給 HP。如果要求您將有缺陷的部件返還給 HP，那麼您必須在規定期限內（通常是五 (5) 個工作日）將缺陷部件發給 HP。有缺陷的部件必須隨所提供的發運材料中的相關文件一起返還。如果未能送還有缺陷的部件，HP 可能會要求您支付更換費用。客戶自行維修時，HP 將承擔所有相關運輸和部件返回費用，並指定快遞商/承運商。

有關 HP 客戶自行維修計劃的詳細信息，請與您當地的服務提供商聯繫。有關北美地區的計劃，請訪問 HP 網站 (<http://www.hp.com/go/selfrepair>)。

客戶自行維修

HP 產品設計了許多「客戶自行維修」(CSR) 的零件以減少維修時間，並且使得更換瑕疵零件時能有更大的彈性。如果在診斷期間 HP (或 HP 服務供應商或維修夥伴) 辨認出此項維修工作可以藉由使用 CSR 零件來完成，則 HP 將直接寄送該零件給您作更換。CSR 零件分為兩種類別：

- **強制的** — 客戶自行維修所使用的零件是強制的。如果您要求 HP 更換這些零件，HP 將會向您收取此服務所需的外出費用與勞動成本。
- **選購的** — 客戶自行維修所使用的零件是選購的。這些零件也設計用於客戶自行維修之用。不過，如果您要求 HP 為您更換，則可能需要也可能不需要負擔額外的費用，端視針對此產品指定的保固服務類型而定。

備註：某些 HP 零件沒有消費者可自行維修的設計。為符合客戶保固，HP 需要授權的服務供應商更換零件。這些零件在圖示的零件目錄中，被標示為「否」。

基於材料取得及環境允許的情況下，CSR 零件將於下一個工作日以快遞寄送。在環境的允許下當天或四小時內送達，則可能需要額外的費用。若您需要協助，可致電「HP 技術支援中心」，會有一位技術人員透過電話來協助您。不論損壞的零件是否必須退回，HP 皆會在與 CSR 替換零件一起運送的材料中註明。若要將損壞的零件退回 HP，您必須在指定的一段時間內（通常為五 (5) 個工作天），將損壞的零件寄回 HP。損壞的零件必須與寄送資料中隨附的相關技術文件一併退還。如果無法退還損壞的零件，HP 可能要向您收取替換費用。針對客戶自行維修情形，HP 將負責所有運費及零件退還費用並指定使用何家快遞/貨運公司。

如需 HP 的「客戶自行維修」方案詳細資訊，請連絡您當地的服務供應商。至於北美方案，請參閱 HP 網站 (<http://www.hp.com/go/selfrepair>)。

고객 셀프 수리

HP 제품은 수리 시간을 최소화하고 결함이 있는 부품 교체 시 더욱 용통성을 발휘할 수 있도록 하기 위해 고객 셀프 수리(CSR) 부품을 다량 사용하여 설계되었습니다. 진단 기간 동안 HP(또는 HP 서비스 공급업체 또는 서비스 협력업체)에서 CSR 부품을 사용하여 수리가 가능하다고 판단되면 HP는 해당 부품을 바로 사용자에게 보내어 사용자가 교체할 수 있도록 합니다. CSR 부품에는 두 가지 종류가 있습니다.

- **고객 셀프 수리가 의무 사항인 필수 부품.** 사용자가 HP에 이 부품의 교체를 요청할 경우 이 서비스에 대한 출장비 및 작업비가 청구됩니다.
- **고객 셀프 수리가 선택 사항인 부품.** 이 부품들도 고객 셀프 수리가 가능하도록 설계되었습니다. 하지만 사용자가 HP에 이 부품의 교체를 요청할 경우 사용자가 구입한 제품에 해당하는 보증 서비스 유형에 따라 추가 비용 없이 교체가 가능할 수 있습니다.

참고: 일부 HP 부품은 고객 셀프 수리가 불가능하도록 설계되었습니다. HP는 만족스러운 고객 보증을 위해 공인 서비스 제공업체를 통해 부품을 교체하도록 하고 있습니다. 이러한 부품들은 Illustrated Parts Catalog에 "No"라고 표시되어 있습니다.

CSR 부품은 재고 상태와 지리적 조건이 허용하는 경우 다음 영업일 납품이 가능하도록 배송이 이루어집니다. 지리적 조건이 허용하는 경우 추가 비용이 청구되는 조건으로 당일 또는 4시간 배송이 가능할 수도 있습니다. 도움이 필요하시면 HP 기술 지원 센터로 전화하십시오. 전문 기술자가 전화로 도움을 줄 것입니다. HP는 결함이 발생한 부품을 HP로 반환해야 하는지 여부를 CSR 교체 부품과 함께 배송된 자료에 지정합니다. 결함이 발생한 부품을 HP로 반환해야 하는 경우에는 지정된 기간 내(통상 영업일 기준 5일)에 HP로 반환해야 합니다. 이 때 결함이 발생한 부품은 제공된 포장 재료에 넣어 관련 설명서와 함께 반환해야 합니다. 결함이 발생한 부품을 반환하지 않는 경우 HP가 교체 부품에 대해 비용을 청구할 수 있습니다. 고객 셀프 수리의 경우, HP는 모든 운송 및 부품 반환 비용을 부담하며 이용할 운송업체 및 택배 서비스를 결정합니다.

HP 고객 셀프 수리 프로그램에 대한 자세한 내용은 가까운 서비스 제공업체에 문의하십시오. 북미 지역의 프로그램에 대해서는 HP 웹 사이트(<http://www.hp.com/go/selfrepair>)를 참조하십시오.

Acronyms and abbreviations

ABEND

abnormal end

ACU

Array Configuration Utility

AMP

Advanced Memory Protection

ASR

Automatic Server Recovery

CSA

Canadian Standards Association

CSR

Customer Self Repair

DDR

double data rate

FBWC

flash-backed write cache

IEC

International Electrotechnical Commission

iLO

Integrated Lights-Out

IML

Integrated Management Log

LFF

large form factor

NMI

nonmaskable interrupt

NVRAM

nonvolatile memory

ORCA

Option ROM Configuration for Arrays

PCIe

peripheral component interconnect express

POST

Power-On Self Test

RBSU

ROM-Based Setup Utility

RDIMM

registered dual in-line memory module

RDP

Rapid Deployment Pack

SAS

serial attached SCSI

SATA

serial ATA

SELV

separated extra low voltage

SFF

small form factor

SIM

Systems Insight Manager

TMRA

recommended ambient operating temperature

TPM

Trusted Platform Module

UID

unit identification

USB

universal serial bus

VCA

Version Control Agent

Documentation feedback

HP is committed to providing documentation that meets your needs. To help us improve the documentation, send any errors, suggestions, or comments to Documentation Feedback (<mailto:docsfeedback@hp.com>). Include the document title and part number, version number, or the URL when submitting your feedback.

Index

A

AC power supply 117, 118, 119
access panel 25
Advanced ECC memory 57, 58, 105
air baffle 34
Array Configuration Utility (ACU) 106
ASR (Automatic Server Recovery) 107
authorized reseller 121
auto-configuration process 104
Automatic Server Recovery (ASR) 107

B

battery 112
BIOS upgrade 98, 107
blue screen event 17
boot options 42, 105
BSMI notice 114
buttons 7

C

cable management arm 25, 40
cables 90
cabling 90, 91, 97
Canadian notice 114
capacitor pack 62, 63
Care Pack 36, 110
Change Control 110
components 7
components, identification 7
configuration of system 42, 98
connectors 7
contacting HP 121
controller 61
crash dump analysis 17
CSR (customer self repair) 121
customer self repair (CSR) 121

D

DC power supply 38
default settings 57
diagnostic tools 98, 101, 107

diagnostics utility 101
DIMM identification 56
DIMM slot locations 17
DIMMs 17, 55
DIMMs, installation 58
DIMMs, single- and dual-rank 55
drive LEDs 19
drivers 108
drives 19

E

electrical grounding requirements 38
electrostatic discharge 115
enabling the Trusted Platform Module 89
environmental requirements 36
environmental specifications 116
Erase Utility 98, 101
error messages 111
European Union notice 114
expansion board options 71
expansion boards 71
expansion slot covers 71
expansion slot covers, removing 71
expansion slots 71, 72, 73
extending server from rack 23

F

FBWC cabling 92
FBWC module 20, 62, 63
features 7, 106
Federal Communications Commission (FCC)
notice 114
firmware 109
front panel buttons 9
front panel components 7

G

grounding methods 115
grounding requirements 38

H

hard drive bays 7

- hard drive cage 76
- hard drive LEDs 19
- hard drives, determining status of 19
- hardware options installation 40, 44
- health driver 107
- health LEDs 9
- heatsink 44
- help resources 121
- hot-plug fans 21, 25
- hot-plug SAS hard drive options 59
- HP Insight Diagnostics 101
- HP Insight Remote Support software 102, 110
- HP Smart Update Manager overview 98, 103
- HP technical support 110, 121

I

- iLO (Integrated Lights-Out) 98, 99, 100
- IML (Integrated Management Log) 98, 100
- Insight Diagnostics 101, 108
- installation services 36
- installation, server options 40, 44
- installing a hot-plug SAS hard drive 59
- installing hardware 44
- installing the full-length expansion board retainer 31
- installing the server into the rack 40
- installing the Trusted Platform Module board 87
- Integrated Lights-Out (iLO) 98
- Integrated Management Log (IML) 100
- Intelligent Provisioning 98, 100

J

- Japanese notice 114

L

- LEDs 12, 19
- LEDs, front panel 19
- LEDs, hard drive 19
- LEDs, SAS hard drive 19
- LEDs, troubleshooting 19, 111

M

- mechanical specifications 116
- memory 52, 55, 56, 57
- memory configurations 57
- memory dump 17
- memory subsystem architecture 55
- memory, configuration requirements 57
- memory, configuring 57

- memory, online spare 57, 105

N

- NIC connectors 13
- NMI header 17

O

- online spare memory 57, 58, 105
- operating system crash 17
- operating systems 42, 109
- optical drive 7, 66
- optical drive cable 91
- optimum environment 36
- Option ROM Configuration for Arrays (ORCA) 98, 107
- options installation 40, 44
- ORCA (Option ROM Configuration for Arrays) 98, 107

P

- PCI expansion slots 14
- PCI riser cage 31
- phone numbers 121
- power distribution unit (PDU) 38
- Power On button 23, 42
- power requirements 38
- power supply 68
- power supply specifications 116, 117, 118, 119
- powering down 23
- preparation procedures 23
- problem diagnosis 111

R

- rack installation 36, 39
- rack mounting hardware 40
- rack resources 36
- rack warnings 39
- RBSU (ROM-Based Setup Utility) 98, 103, 104, 105
- rear panel components 13
- rear panel, accessing 25
- redundant ROM 108
- registering the server 43
- regulatory compliance notices 114
- removing a hot-plug SAS hard drive 60
- removing server from rack 24
- removing the access panel 25
- required information 121
- retaining the recovery key/password 89

ROM redundancy 108
ROMPaq utility 98, 107, 108

S

safety considerations 39, 108, 114
SAS and SATA device numbers 18
scripted installation 102
serial number 105
series number 114
server features and options 44
server setup 108
shipping carton contents 40
space and airflow requirements 37
specifications 116, 117, 118, 119
specifications, environmental 116
specifications, mechanical 116
specifications, power 116, 117, 118, 119
specifications, server 116
static electricity 115
support 121
supported operating systems 109
switches 17
system battery 112
system board components 15
system components 7
system maintenance switch 16, 17
system power LED 9
Systems Insight Display 11, 12
Systems Insight Display LEDs 11, 12

T

Taiwan battery recycling notice 114
technical support 110, 121
telephone numbers 121
temperature requirements 37
TPM (Trusted Platform Module) 86, 89
TPM connector 15
troubleshooting 111

U

UID LED 17
updating the system ROM 108
USB connectors 7
USB support 107
utilities 98, 106
utilities, deployment 98, 102, 103

V

ventilation 36
Version Control 109
video connector 7

W

warnings 39
website, HP 121