

HP ProLiant DL160 Gen8 Server Maintenance and Service Guide

Abstract

This guide describes identification and maintenance procedures, diagnostic tools, specifications and requirements for hardware components and software. This guide is for an experienced service technician. HP assumes you are qualified in the servicing of computer equipment, trained in recognizing hazards in products, and are familiar with weight and stability precautions.



Part Number: 670554-001
March 2012
Edition: 1

© Copyright 2012 Hewlett-Packard Development Company, L.P.

The information contained herein is subject to change without notice. The only warranties for HP products and services are set forth in the express warranty statements accompanying such products and services. Nothing herein should be construed as constituting an additional warranty. HP shall not be liable for technical or editorial errors or omissions contained herein.

Microsoft® and Windows® are U.S. registered trademarks of Microsoft Corporation.

Intel® and Xeon® are registered trademarks of Intel Corporation in the U.S. and other countries.

Contents

Customer self repair	5
Parts only warranty service	5
Illustrated parts catalog	16
Mechanical components.....	16
System components	19
Removal and replacement procedures	24
Required tools.....	24
Safety considerations.....	24
Preventing electrostatic discharge	24
Symbols on equipment	24
Server warnings and cautions	25
Preparation procedures.....	25
Power down the server.....	26
Extend the server from the rack.....	26
Remove the server from the rack	27
Access panel	28
Rack bezel	28
Power supply module.....	29
Multioutput power supply backplane.....	29
Common slot power supply backplane.....	31
DVD-ROM or DVD-RW drive	32
Drive blank.....	33
Hot-plug drive	33
Fan blank.....	34
Fan module	35
Front video adapter	37
FlexibleLOM option	37
LFF drive cage assembly.....	39
SFF drive cage assembly	40
Processor air baffle.....	41
PCI riser cage	42
Expansion boards	43
FBWC capacitor pack	44
DIMM blanks.....	46
DIMMs.....	46
Internal USB cable.....	47
Heatsink.....	48
Processor	50
System board	55
System battery	62
HP Trusted Platform Module	63
Cabling	64
Cabling overview.....	64
Data cabling	64

P420 Smart Array Controller cabling	64
SATA cabling	65
Power cabling	65
Server power cabling	65
FBWC capacitor pack cabling	66
Front panel cabling	67
Internal USB cabling	67
Diagnostic tools	69
Troubleshooting resources	69
HP ROM-Based Setup Utility	69
HP Insight Diagnostics	69
HP Insight Diagnostics survey functionality	70
Integrated Management Log	70
Automatic Server Recovery	70
HP Insight Remote Support software	71
Troubleshooting	72
Troubleshooting resources	72
Component identification	73
Front panel components	73
Front panel LEDs and buttons	74
Rear panel components	74
Rear panel LEDs and buttons	75
System board components	76
DIMM slots	77
System maintenance switch	77
NMI jumper	78
Device numbers	78
Drive LED definitions	79
Fan modules	79
T-10/T-15 Torx screwdriver	81
Specifications	82
Environmental specifications	82
Server specifications	82
Power supply specifications	82
HP 460 W CS Power Supply (94%) specifications	83
HP 500 W Multi-output Power Supply specifications	83
Hot-plug power supply calculations	84
Acronyms and abbreviations	85
Documentation feedback	87
Index	88

Customer self repair

HP products are designed with many Customer Self Repair (CSR) parts to minimize repair time and allow for greater flexibility in performing defective parts replacement. If during the diagnosis period HP (or HP service providers or service partners) identifies that the repair can be accomplished by the use of a CSR part, HP will ship that part directly to you for replacement. There are two categories of CSR parts:

- **Mandatory**—Parts for which customer self repair is mandatory. If you request HP to replace these parts, you will be charged for the travel and labor costs of this service.
- **Optional**—Parts for which customer self repair is optional. These parts are also designed for customer self repair. If, however, you require that HP replace them for you, there may or may not be additional charges, depending on the type of warranty service designated for your product.

NOTE: Some HP parts are not designed for customer self repair. In order to satisfy the customer warranty, HP requires that an authorized service provider replace the part. These parts are identified as "No" in the Illustrated Parts Catalog.

Based on availability and where geography permits, CSR parts will be shipped for next business day delivery. Same day or four-hour delivery may be offered at an additional charge where geography permits. If assistance is required, you can call the HP Technical Support Center and a technician will help you over the telephone. HP specifies in the materials shipped with a replacement CSR part whether a defective part must be returned to HP. In cases where it is required to return the defective part to HP, you must ship the defective part back to HP within a defined period of time, normally five (5) business days. The defective part must be returned with the associated documentation in the provided shipping material. Failure to return the defective part may result in HP billing you for the replacement. With a customer self repair, HP will pay all shipping and part return costs and determine the courier/carrier to be used.

For more information about HP's Customer Self Repair program, contact your local service provider. For the North American program, refer to the HP website (<http://www.hp.com/go/selfrepair>).

Parts only warranty service

Your HP Limited Warranty may include a parts only warranty service. Under the terms of parts only warranty service, HP will provide replacement parts free of charge.

For parts only warranty service, CSR part replacement is mandatory. If you request HP to replace these parts, you will be charged for the travel and labor costs of this service.

Réparation par le client (CSR)

Les produits HP comportent de nombreuses pièces CSR (Customer Self Repair = réparation par le client) afin de minimiser les délais de réparation et faciliter le remplacement des pièces défectueuses. Si pendant la période de diagnostic, HP (ou ses partenaires ou mainteneurs agréés) détermine que la réparation peut être effectuée à l'aide d'une pièce CSR, HP vous l'envoie directement. Il existe deux catégories de pièces CSR:

Obligatoire - Pièces pour lesquelles la réparation par le client est obligatoire. Si vous demandez à HP de remplacer ces pièces, les coûts de déplacement et main d'œuvre du service vous seront facturés.

Facultatif - Pièces pour lesquelles la réparation par le client est facultative. Ces pièces sont également conçues pour permettre au client d'effectuer lui-même la réparation. Toutefois, si vous demandez à HP de remplacer ces pièces, l'intervention peut ou non vous être facturée, selon le type de garantie applicable à votre produit.

REMARQUE: Certaines pièces HP ne sont pas conçues pour permettre au client d'effectuer lui-même la réparation. Pour que la garantie puisse s'appliquer, HP exige que le remplacement de la pièce soit effectué par un Mainteneur Agréé. Ces pièces sont identifiées par la mention "Non" dans le Catalogue illustré.

Les pièces CSR sont livrées le jour ouvré suivant, dans la limite des stocks disponibles et selon votre situation géographique. Si votre situation géographique le permet et que vous demandez une livraison le jour même ou dans les 4 heures, celle-ci vous sera facturée. Pour bénéficier d'une assistance téléphonique, appelez le Centre d'assistance technique HP. Dans les documents envoyés avec la pièce de rechange CSR, HP précise s'il est nécessaire de lui retourner la pièce défectueuse. Si c'est le cas, vous devez le faire dans le délai indiqué, généralement cinq (5) jours ouvrés. La pièce et sa documentation doivent être retournées dans l'emballage fourni. Si vous ne retournez pas la pièce défectueuse, HP se réserve le droit de vous facturer les coûts de remplacement. Dans le cas d'une pièce CSR, HP supporte l'ensemble des frais d'expédition et de retour, et détermine la société de courses ou le transporteur à utiliser.

Pour plus d'informations sur le programme CSR de HP, contactez votre Mainteneur Agréé local. Pour plus d'informations sur ce programme en Amérique du Nord, consultez le site Web HP (<http://www.hp.com/go/selfrepair>).

Service de garantie "pièces seules"

Votre garantie limitée HP peut inclure un service de garantie "pièces seules". Dans ce cas, les pièces de rechange fournies par HP ne sont pas facturées.

Dans le cadre de ce service, la réparation des pièces CSR par le client est obligatoire. Si vous demandez à HP de remplacer ces pièces, les coûts de déplacement et main d'œuvre du service vous seront facturés.

Riparazione da parte del cliente

Per abbreviare i tempi di riparazione e garantire una maggiore flessibilità nella sostituzione di parti difettose, i prodotti HP sono realizzati con numerosi componenti che possono essere riparati direttamente dal cliente (CSR, Customer Self Repair). Se in fase di diagnostica HP (o un centro di servizi o di assistenza HP) identifica il guasto come riparabile mediante un ricambio CSR, HP lo spedisce direttamente al cliente per la sostituzione. Vi sono due categorie di parti CSR:

Obbligatorie – Parti che devono essere necessariamente riparate dal cliente. Se il cliente ne affida la riparazione ad HP, deve sostenere le spese di spedizione e di manodopera per il servizio.

Opzionali – Parti la cui riparazione da parte del cliente è facoltativa. Si tratta comunque di componenti progettati per questo scopo. Se tuttavia il cliente ne richiede la sostituzione ad HP, potrebbe dover sostenere spese aggiuntive a seconda del tipo di garanzia previsto per il prodotto.

NOTA: alcuni componenti HP non sono progettati per la riparazione da parte del cliente. Per rispettare la garanzia, HP richiede che queste parti siano sostituite da un centro di assistenza autorizzato. Tali parti sono identificate da un "No" nel Catalogo illustrato dei componenti.

In base alla disponibilità e alla località geografica, le parti CSR vengono spedite con consegna entro il giorno lavorativo seguente. La consegna nel giorno stesso o entro quattro ore è offerta con un supplemento di costo solo in alcune zone. In caso di necessità si può richiedere l'assistenza telefonica di un addetto del centro di supporto tecnico HP. Nel materiale fornito con una parte di ricambio CSR, HP specifica se il cliente deve restituire dei componenti. Qualora sia richiesta la resa ad HP del componente difettoso, lo si deve spedire ad HP entro un determinato periodo di tempo, generalmente cinque (5) giorni lavorativi. Il componente difettoso deve essere restituito con la documentazione associata nell'imballo di spedizione fornito. La mancata restituzione del componente può comportare la fatturazione del ricambio da parte di HP. Nel caso di riparazione da parte del cliente, HP sostiene tutte le spese di spedizione e resa e sceglie il corriere/vettore da utilizzare.

Per ulteriori informazioni sul programma CSR di HP contattare il centro di assistenza di zona. Per il programma in Nord America fare riferimento al sito Web HP (<http://www.hp.com/go/selfrepair>).

Servizio di garanzia per i soli componenti

La garanzia limitata HP può includere un servizio di garanzia per i soli componenti. Nei termini di garanzia del servizio per i soli componenti, HP fornirà gratuitamente le parti di ricambio.

Per il servizio di garanzia per i soli componenti è obbligatoria la formula CSR che prevede la riparazione da parte del cliente. Se il cliente invece richiede la sostituzione ad HP, dovrà sostenere le spese di spedizione e di manodopera per il servizio.

Customer Self Repair

HP Produkte enthalten viele CSR-Teile (Customer Self Repair), um Reparaturzeiten zu minimieren und höhere Flexibilität beim Austausch defekter Bauteile zu ermöglichen. Wenn HP (oder ein HP Servicepartner) bei der Diagnose feststellt, dass das Produkt mithilfe eines CSR-Teils repariert werden kann, sendet Ihnen HP dieses Bauteil zum Austausch direkt zu. CSR-Teile werden in zwei Kategorien unterteilt:

Zwingend – Teile, für die das Customer Self Repair-Verfahren zwingend vorgegeben ist. Wenn Sie den Austausch dieser Teile von HP vornehmen lassen, werden Ihnen die Anfahrt- und Arbeitskosten für diesen Service berechnet.

Optional – Teile, für die das Customer Self Repair-Verfahren optional ist. Diese Teile sind auch für Customer Self Repair ausgelegt. Wenn Sie jedoch den Austausch dieser Teile von HP vornehmen lassen möchten, können bei diesem Service je nach den für Ihr Produkt vorgesehenen Garantiebedingungen zusätzliche Kosten anfallen.

HINWEIS: Einige Teile sind nicht für Customer Self Repair ausgelegt. Um den Garantieanspruch des Kunden zu erfüllen, muss das Teil von einem HP Servicepartner ersetzt werden. Im illustrierten Teilekatalog sind diese Teile mit „No“ bzw. „Nein“ gekennzeichnet.

CSR-Teile werden abhängig von der Verfügbarkeit und vom Lieferziel am folgenden Geschäftstag geliefert. Für bestimmte Standorte ist eine Lieferung am selben Tag oder innerhalb von vier Stunden gegen einen Aufpreis verfügbar. Wenn Sie Hilfe benötigen, können Sie das HP technische Support Center anrufen und sich von einem Mitarbeiter per Telefon helfen lassen. Den Materialien, die mit einem CSR-Ersatzteil geliefert werden, können Sie entnehmen, ob das defekte Teil an HP zurückgeschickt werden muss. Wenn es erforderlich ist, das defekte Teil an HP zurückzuschicken, müssen Sie dies innerhalb eines vorgegebenen Zeitraums tun, in der Regel innerhalb von fünf (5) Geschäftstagen. Das defekte Teil muss mit der zugehörigen Dokumentation in der Verpackung zurückgeschickt werden, die im Lieferumfang enthalten ist. Wenn Sie das

defekte Teil nicht zurückschicken, kann HP Ihnen das Ersatzteil in Rechnung stellen. Im Falle von Customer Self Repair kommt HP für alle Kosten für die Lieferung und Rücksendung auf und bestimmt den Kurier-/Frachtdienst.

Weitere Informationen über das HP Customer Self Repair Programm erhalten Sie von Ihrem Servicepartner vor Ort. Informationen über das CSR-Programm in Nordamerika finden Sie auf der HP Website unter (<http://www.hp.com/go/selfrepair>).

Parts-only Warranty Service (Garantieservice ausschließlich für Teile)

Ihre HP Garantie umfasst möglicherweise einen Parts-only Warranty Service (Garantieservice ausschließlich für Teile). Gemäß den Bestimmungen des Parts-only Warranty Service stellt HP Ersatzteile kostenlos zur Verfügung.

Für den Parts-only Warranty Service ist das CSR-Verfahren zwingend vorgegeben. Wenn Sie den Austausch dieser Teile von HP vornehmen lassen, werden Ihnen die Anfahrt- und Arbeitskosten für diesen Service berechnet.

Reparaciones del propio cliente

Los productos de HP incluyen muchos componentes que el propio usuario puede reemplazar (*Customer Self Repair*, CSR) para minimizar el tiempo de reparación y ofrecer una mayor flexibilidad a la hora de realizar sustituciones de componentes defectuosos. Si, durante la fase de diagnóstico, HP (o los proveedores o socios de servicio de HP) identifica que una reparación puede llevarse a cabo mediante el uso de un componente CSR, HP le enviará dicho componente directamente para que realice su sustitución. Los componentes CSR se clasifican en dos categorías:

- **Obligatorio:** componentes para los que la reparación por parte del usuario es obligatoria. Si solicita a HP que realice la sustitución de estos componentes, tendrá que hacerse cargo de los gastos de desplazamiento y de mano de obra de dicho servicio.
- **Opcional:** componentes para los que la reparación por parte del usuario es opcional. Estos componentes también están diseñados para que puedan ser reparados por el usuario. Sin embargo, si precisa que HP realice su sustitución, puede o no conllevar costes adicionales, dependiendo del tipo de servicio de garantía correspondiente al producto.

NOTA: Algunos componentes no están diseñados para que puedan ser reparados por el usuario. Para que el usuario haga valer su garantía, HP pone como condición que un proveedor de servicios autorizado realice la sustitución de estos componentes. Dichos componentes se identifican con la palabra "No" en el catálogo ilustrado de componentes.

Según la disponibilidad y la situación geográfica, los componentes CSR se enviarán para que lleguen a su destino al siguiente día laborable. Si la situación geográfica lo permite, se puede solicitar la entrega en el mismo día o en cuatro horas con un coste adicional. Si precisa asistencia técnica, puede llamar al Centro de asistencia técnica de HP y recibirá ayuda telefónica por parte de un técnico. Con el envío de materiales para la sustitución de componentes CSR, HP especificará si los componentes defectuosos deberán devolverse a HP. En aquellos casos en los que sea necesario devolver algún componente a HP, deberá hacerlo en el periodo de tiempo especificado, normalmente cinco días laborables. Los componentes defectuosos deberán devolverse con toda la documentación relacionada y con el embalaje de envío. Si no

enviara el componente defectuoso requerido, HP podrá cobrarle por el de sustitución. En el caso de todas sustituciones que lleve a cabo el cliente, HP se hará cargo de todos los gastos de envío y devolución de componentes y escogerá la empresa de transporte que se utilice para dicho servicio.

Para obtener más información acerca del programa de Reparaciones del propio cliente de HP, póngase en contacto con su proveedor de servicios local. Si está interesado en el programa para Norteamérica, visite la página web de HP siguiente (<http://www.hp.com/go/selfrepair>).

Servicio de garantía exclusivo de componentes

La garantía limitada de HP puede que incluya un servicio de garantía exclusivo de componentes. Según las condiciones de este servicio exclusivo de componentes, HP le facilitará los componentes de repuesto sin cargo adicional alguno.

Para este servicio de garantía exclusivo de componentes, es obligatoria la sustitución de componentes por parte del usuario (CSR). Si solicita a HP que realice la sustitución de estos componentes, tendrá que hacerse cargo de los gastos de desplazamiento y de mano de obra de dicho servicio.

Customer Self Repair

Veel onderdelen in HP producten zijn door de klant zelf te repareren, waardoor de reparatieduur tot een minimum beperkt kan blijven en de flexibiliteit in het vervangen van defecte onderdelen groter is. Deze onderdelen worden CSR-onderdelen (Customer Self Repair) genoemd. Als HP (of een HP Service Partner) bij de diagnose vaststelt dat de reparatie kan worden uitgevoerd met een CSR-onderdeel, verzendt HP dat onderdeel rechtstreeks naar u, zodat u het defecte onderdeel daarmee kunt vervangen. Er zijn twee categorieën CSR-onderdelen:

Verplicht: Onderdelen waarvoor reparatie door de klant verplicht is. Als u HP verzoekt deze onderdelen voor u te vervangen, worden u voor deze service reiskosten en arbeidsloon in rekening gebracht.

Optioneel: Onderdelen waarvoor reparatie door de klant optioneel is. Ook deze onderdelen zijn ontworpen voor reparatie door de klant. Als u echter HP verzoekt deze onderdelen voor u te vervangen, kunnen daarvoor extra kosten in rekening worden gebracht, afhankelijk van het type garantieservice voor het product.

OPMERKING: Sommige HP onderdelen zijn niet ontwikkeld voor reparatie door de klant. In verband met de garantievoorwaarden moet het onderdeel door een geautoriseerde Service Partner worden vervangen. Deze onderdelen worden in de geïllustreerde onderdelencatalogus aangemerkt met "Nee".

Afhankelijk van de leverbaarheid en de locatie worden CSR-onderdelen verzonden voor levering op de eerstvolgende werkdag. Levering op dezelfde dag of binnen vier uur kan tegen meerkosten worden aangeboden, indien dit mogelijk is gezien de locatie. Indien assistentie gewenst is, belt u een HP Service Partner om via de telefoon technische ondersteuning te ontvangen. HP vermeldt in de documentatie bij het vervangende CSR-onderdeel of het defecte onderdeel aan HP moet worden geretourneerd. Als het defecte onderdeel aan HP moet worden teruggezonden, moet u het defecte onderdeel binnen een bepaalde periode, gewoonlijk vijf (5) werkdagen, retourneren aan HP. Het defecte onderdeel moet met de bijbehorende documentatie worden geretourneerd in het meegeleverde verpakkingsmateriaal. Als u het defecte onderdeel niet terugzendt, kan HP u voor het vervangende onderdeel kosten in rekening brengen. Bij reparatie door de klant betaalt HP alle verzendkosten voor het vervangende en geretourneerde onderdeel en kiest HP zelf welke koerier/transportonderneming hiervoor wordt gebruikt.

Neem contact op met een Service Partner voor meer informatie over het Customer Self Repair programma van HP. Informatie over Service Partners vindt u op de HP website (<http://www.hp.com/go/selfrepair>).

Garantieservice "Parts Only"

Het is mogelijk dat de HP garantie alleen de garantieservice "Parts Only" omvat. Volgens de bepalingen van de Parts Only garantieservice zal HP kosteloos vervangende onderdelen ter beschikking stellen.

Voor de Parts Only garantieservice is vervanging door CSR-onderdelen verplicht. Als u HP verzoekt deze onderdelen voor u te vervangen, worden u voor deze service reiskosten en arbeidsloon in rekening gebracht.

Reparo feito pelo cliente

Os produtos da HP são projetados com muitas peças para reparo feito pelo cliente (CSR) de modo a minimizar o tempo de reparo e permitir maior flexibilidade na substituição de peças com defeito. Se, durante o período de diagnóstico, a HP (ou fornecedores/parceiros de serviço da HP) concluir que o reparo pode ser efetuado pelo uso de uma peça CSR, a peça de reposição será enviada diretamente ao cliente. Existem duas categorias de peças CSR:

Obrigatória – Peças cujo reparo feito pelo cliente é obrigatório. Se desejar que a HP substitua essas peças, serão cobradas as despesas de transporte e mão-de-obra do serviço.

Opcional – Peças cujo reparo feito pelo cliente é opcional. Essas peças também são projetadas para o reparo feito pelo cliente. No entanto, se desejar que a HP as substitua, pode haver ou não a cobrança de taxa adicional, dependendo do tipo de serviço de garantia destinado ao produto.

OBSERVAÇÃO: Algumas peças da HP não são projetadas para o reparo feito pelo cliente. A fim de cumprir a garantia do cliente, a HP exige que um técnico autorizado substitua a peça. Essas peças estão identificadas com a marca "No" (Não), no catálogo de peças ilustrado.

Conforme a disponibilidade e o local geográfico, as peças CSR serão enviadas no primeiro dia útil após o pedido. Onde as condições geográficas permitirem, a entrega no mesmo dia ou em quatro horas pode ser feita mediante uma taxa adicional. Se precisar de auxílio, entre em contato com o Centro de suporte técnico da HP para que um técnico o ajude por telefone. A HP especifica nos materiais fornecidos com a peça CSR de reposição se a peça com defeito deve ser devolvida à HP. Nos casos em que isso for necessário, é preciso enviar a peça com defeito à HP dentro do período determinado, normalmente cinco (5) dias úteis. A peça com defeito deve ser enviada com a documentação correspondente no material de transporte fornecido. Caso não o faça, a HP poderá cobrar a reposição. Para as peças de reparo feito pelo cliente, a HP paga todas as despesas de transporte e de devolução da peça e determina a transportadora/serviço postal a ser utilizado.

Para obter mais informações sobre o programa de reparo feito pelo cliente da HP, entre em contato com o fornecedor de serviços local. Para o programa norte-americano, visite o site da HP (<http://www.hp.com/go/selfrepair>).

Serviço de garantia apenas para peças

A garantia limitada da HP pode incluir um serviço de garantia apenas para peças. Segundo os termos do serviço de garantia apenas para peças, a HP fornece as peças de reposição sem cobrar nenhuma taxa.

No caso desse serviço, a substituição de peças CSR é obrigatória. Se desejar que a HP substitua essas peças, serão cobradas as despesas de transporte e mão-de-obra do serviço.

顧客自己修理保証サービス

修理時間を短縮し、故障部品の交換における高い柔軟性を確保するために、HP製品には多数の顧客自己修理（CSR）部品があります。診断の際に、CSR部品を使用すれば修理ができるとHP（HPまたはHP正規保守代理店）が判断した場合、HPはその部品を直接、お客様に発送し、お客様に交換していただきます。CSR部品には以下の2通りがあります。

- 必須 - 顧客自己修理が必須の部品。当該部品について、もしもお客様がHPに交換作業を依頼される場合には、その修理サービスに関する交通費および人件費がお客様に請求されます。
- 任意 - 顧客自己修理が任意である部品。この部品も顧客自己修理用です。当該部品について、もしもお客様がHPに交換作業を依頼される場合には、お買い上げの製品に適用される保証サービス内容の範囲内においては、別途費用を負担していただくことなく保証サービスを受けることができます。

注： HP製品の一部の部品は、顧客自己修理用ではありません。製品の保証を継続するためには、HPまたはHP正規保守代理店による交換作業が必須となります。部品カタログには、当該部品が顧客自己修理除外品である旨が記載されています。

部品供給が可能な場合、地域によっては、CSR部品を翌営業日に届くように発送します。また、地域によっては、追加費用を負担いただくことにより同日または4時間以内に届くように発送することも可能な場合があります。サポートが必要なときは、HPの修理受付窓口にご電話いただければ、技術者が電話でアドバイスします。交換用のCSR部品または同梱物には、故障部品をHPに返送する必要があるかどうかが表示されています。故障部品をHPに返送する必要がある場合は、指定期限内（通常は5営業日以内）に故障部品をHPに返送してください。故障部品を返送する場合は、届いた時の梱包箱に関連書類とともに入れてください。故障部品を返送しない場合、HPから部品費用が請求されます。顧客自己修理の際には、HPは送料および部品返送費を全額負担し、使用する宅配便会社や運送会社を指定します。

部品のみ保証サービス

HP保証サービスには、部品のみ保証サービスが適用される場合があります。このサービスでは、交換部品は無償で提供されます。

部品のみ保証サービスにおいては、CSR部品をお客様により交換作業していただくことが必須となります。当該部品について、もしもお客様がHPに交換作業を依頼される場合には、その修理サービスに関する交通費および人件費はお客様の負担となります。

客户自行维修

HP 产品提供许多客户自行维修 (CSR) 部件，以尽可能缩短维修时间和在更换缺陷部件方面提供更大的灵活性。如果在诊断期间 HP（或 HP 服务提供商或服务合作伙伴）确定可以通过使用 CSR 部件完成维修，HP 将直接把该部件发送给您进行更换。有两类 CSR 部件：

- **强制性的** — 要求客户必须自行维修的部件。如果您请求 HP 更换这些部件，则必须为该服务支付差旅费和人工费用。
- **可选的** — 客户可以选择是否自行维修的部件。这些部件也是为客户自行维修设计的。不过，如果您要求 HP 为您更换这些部件，则根据为您的产品指定的保修服务类型，HP 可能收取或不再收取任何附加费用。

注：某些 HP 部件的设计并未考虑客户自行维修。为了满足客户保修的需要，HP 要求授权服务提供商更换相关部件。这些部件在部件图解目录中标记为“否”。

CSR 部件将在下一个工作日发运（取决于备货情况和允许的地理范围）。在允许的地理范围内，可在当天或四小时内发运，但要收取额外费用。如果需要帮助，您可以致电 HP 技术支持中心，将会有技术人员通过电话为您提供帮助。HP 会在随更换的 CSR 部件发运的材料中指明是否必须将有缺陷的部件返还给 HP。如果您要求将有缺陷的部件返还给 HP，那么您必须在规定期限内（通常是五 (5) 个工作日）将缺陷部件发给 HP。有缺陷的部件必须随所提供的发运材料中的相关文件一起返还。如果未能送还有缺陷的部件，HP 可能会要求您支付更换费用。客户自行维修时，HP 将承担所有相关运输和部件返回费用，并指定快递商/承运商。

有关 HP 客户自行维修计划的详细信息，请与您当地的服务提供商联系。有关北美地区的计划，请访问 HP 网站 (<http://www.hp.com/go/selfrepair>)。

仅部件保修服务

您的 HP 有限保修服务可能涉及仅部件保修服务。根据仅部件保修服务条款的规定，HP 将免费提供更换的部件。

仅部件保修服务要求进行 CSR 部件更换。如果您请求 HP 更换这些部件，则必须为该服务支付差旅费和人工费用。

客戶自行維修

HP 產品設計了許多「客戶自行維修」(CSR) 的零件以減少維修時間，並且使得更換瑕疵零件時能有更大的彈性。如果在診斷期間 HP (或 HP 服務供應商或維修夥伴) 辨認出此項維修工作可以藉由使用 CSR 零件來完成，則 HP 將直接寄送該零件給您作更換。CSR 零件分為兩種類別：

- **強制的** — 客戶自行維修所使用的零件是強制性的。如果您要求 HP 更換這些零件，HP 將會向您收取此服務所需的外出費用與勞動成本。
- **選購的** — 客戶自行維修所使用的零件是選購的。這些零件也設計用於客戶自行維修之用。不過，如果您要求 HP 為您更換，則可能需要也可能不需要負擔額外的費用，端視針對此產品指定的保固服務類型而定。

備註：某些 HP 零件沒有消費者可自行維修的設計。為符合客戶保固，HP 需要授權的服務供應商更換零件。這些零件在圖示的零件目錄中，被標示為「否」。

基於材料取得及環境允許的情況下，CSR 零件將於下一個工作日以快遞寄送。在環境的允許下當天或四小時內送達，則可能需要額外的費用。若您需要協助，可致電「HP 技術支援中心」，會有一位技術人員透過電話來協助您。不論損壞的零件是否必須退回，HP 皆會在與 CSR 替換零件一起運送的材料中註明。若要將損壞的零件退回 HP，您必須在指定的一段時間內（通常為五 (5) 個工作天），將損壞的零件寄回 HP。損壞的零件必須與寄送資料中隨附的相關技術文件一併退還。如果無法退還損壞的零件，HP 可能要向您收取替換費用。針對客戶自行維修情形，HP 將負責所有運費及零件退還費用並指定使用何家快遞/貨運公司。

如需 HP 的「客戶自行維修」方案詳細資訊，請連絡您當地的服務供應商。至於北美方案，請參閱 HP 網站 (<http://www.hp.com/go/selfrepair>)。

僅限零件的保固服務

您的「HP 有限保固」可能包含僅限零件的保固服務。在僅限零件的保固服務情況下，HP 將免費提供替換零件。

針對僅限零件的保固服務，CSR 零件替換是強制性的。如果您要求 HP 更換這些零件，HP 將會向您收取此服務所需的外出費用與勞動成本。

고객 셀프 수리

HP 제품은 수리 시간을 최소화하고 결함이 있는 부품 교체 시 더욱 융통성을 발휘할 수 있도록 하기 위해 고객 셀프 수리(CSR) 부품을 다량 사용하여 설계되었습니다. 진단 기간 동안 HP(또는 HP 서비스 공급업체 또는 서비스 협력업체)에서 CSR 부품을 사용하여 수리가 가능하다고 판단되면 HP는 해당 부품을 바로 사용자에게 보내어 사용자가 교체할 수 있도록 합니다. CSR 부품에는 두 가지 종류가 있습니다.

- **고객 셀프 수리가 의무 사항인 필수 부품.** 사용자가 HP에 이 부품의 교체를 요청할 경우 이 서비스에 대한 출장비 및 작업비가 청구됩니다.
- **고객 셀프 수리가 선택 사항인 부품.** 이 부품들도 고객 셀프 수리가 가능하도록 설계되었습니다. 하지만 사용자가 HP에 이 부품의 교체를 요청할 경우 사용자가 구입한 제품에 해당하는 보증 서비스 유형에 따라 추가 비용 없이 교체가 가능할 수 있습니다.

참고: 일부 HP 부품은 고객 셀프 수리가 불가능하도록 설계되었습니다. HP는 만족스러운 고객 보증을 위해 공인 서비스 제공업체를 통해 부품을 교체하도록 하고 있습니다. 이러한 부품들은 Illustrated Parts Catalog에 "No"라고 표시되어 있습니다.

CSR 부품은 재고 상태와 지리적 조건이 허용하는 경우 다음 영업일 납품이 가능하도록 배송이 이루어집니다. 지리적 조건이 허용하는 경우 추가 비용이 청구되는 조건으로 당일 또는 4시간 배송이 가능할 수도 있습니다. 도움이 필요하시면 HP 기술 지원 센터로 전화하십시오. 전문 기술자가 전화로 도움을 줄 것입니다. HP는 결함이 발생한 부품을 HP로 반환해야 하는지 여부를 CSR 교체 부품과 함께 배송된 자료에 지정합니다. 결함이 발생한 부품을 HP로 반환해야 하는 경우에는 지정된 기간 내(통상 영업일 기준 5일)에 HP로 반환해야 합니다. 이 때 결함이 발생한 부품은 제공된 포장 재료에 넣어 관련 설명서와 함께 반환해야 합니다. 결함이 발생한 부품을 반환하지 않는 경우 HP가 교체 부품에 대해 비용을 청구할 수 있습니다. 고객 셀프 수리의 경우, HP는 모든 운송 및 부품 반환 비용을 부담하며 이용할 운송업체 및 택배 서비스를 결정합니다.

HP 고객 셀프 수리 프로그램에 대한 자세한 내용은 가까운 서비스 제공업체에 문의하십시오. 북미 지역의 프로그램에 대해서는 HP 웹 사이트(<http://www.hp.com/go/selfrepair>)를 참조하십시오.

부품 제공 보증 서비스

HP 제한 보증에는 부품 제공 보증 서비스가 포함될 수 있습니다. 이러한 경우 HP는 부품 제공 보증 서비스의 조건에 따라 교체 부품만을 무료로 제공합니다.

부품 제공 보증 서비스 제공 시 CSR 부품 교체는 의무 사항입니다. 사용자가 HP에 이 부품의 교체를 요청할 경우 이 서비스에 대한 출장비 및 작업비가 청구됩니다.

Illustrated parts catalog

Mechanical components

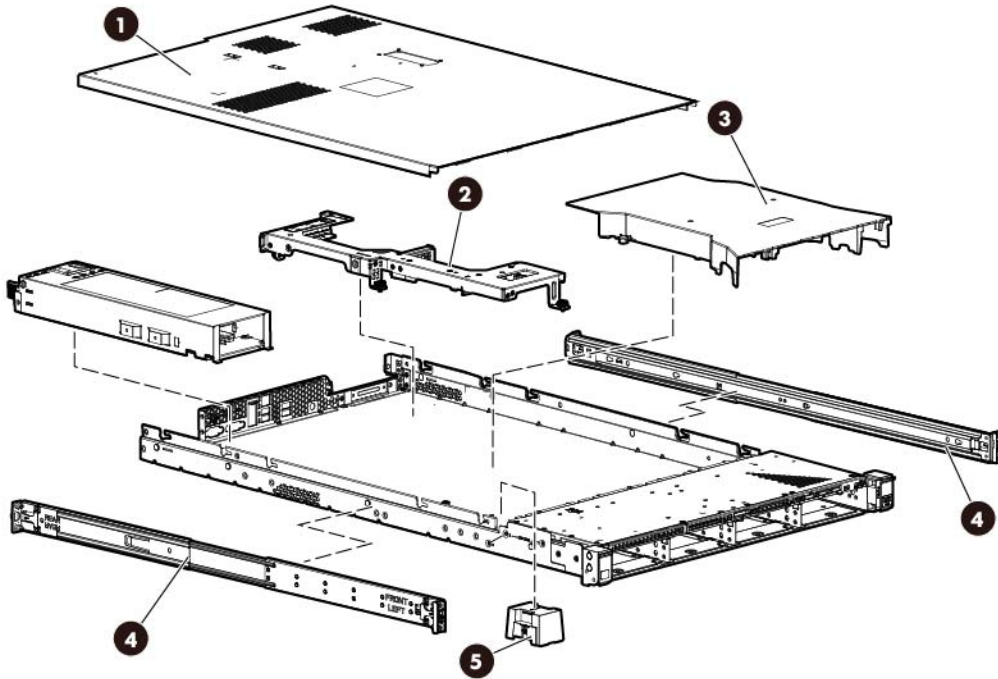

Item	Description	Spare part number	Customer self repair (on page 5)
1	Access panel	683064-001	Mandatory ¹
2	PCI riser cage	683062-001	Mandatory ¹
3	Processor air baffle	677060-001	Mandatory ¹
4	Rail kit	—	—
	a) Friction rail kit	662536-001	Mandatory ¹
	b) Ball bearing rail kit, LFF*	675041-001	Mandatory ¹
	c) Ball bearing rail kit, SFF*	675042-001	Mandatory ¹
5	Fan blank	671354-001	Mandatory ¹

¹Mandatory—Parts for which customer self repair is mandatory. If you request HP to replace these parts, you will be charged for the travel and labor costs of this service.

²Optional—Parts for which customer self repair is optional. These parts are also designed for customer self repair. If, however, you require that HP replace them for you, there may or may not be additional charges, depending on the type of warranty service designated for your product.

³No—Some HP parts are not designed for customer self repair. In order to satisfy the customer warranty, HP requires that an authorized service provider replace the part. These parts are identified as "No" in the Illustrated Parts Catalog.

¹Mandatory: Obligatoire—Pièces pour lesquelles la réparation par le client est obligatoire. Si vous demandez à HP de remplacer ces pièces, les coûts de déplacement et main d'œuvre du service vous seront facturés.

²Optional: Facultatif—Pièces pour lesquelles la réparation par le client est facultative. Ces pièces sont également conçues pour permettre au client d'effectuer lui-même la réparation. Toutefois, si vous demandez à HP de remplacer ces pièces, l'intervention peut ou non vous être facturée, selon le type de garantie applicable à votre produit.

³No: Non—Certaines pièces HP ne sont pas conçues pour permettre au client d'effectuer lui-même la réparation. Pour que la garantie puisse s'appliquer, HP exige que le remplacement de la pièce soit effectué par un Mainteneur Agréé. Ces pièces sont identifiées par la mention "Non" dans le Catalogue illustré.

¹Mandatory: Obbligatorie—Parti che devono essere necessariamente riparate dal cliente. Se il cliente ne affida la riparazione ad HP, deve sostenere le spese di spedizione e di manodopera per il servizio.

²Optional: Opzionali—Parti la cui riparazione da parte del cliente è facoltativa. Si tratta comunque di componenti progettati per questo scopo. Se tuttavia il cliente ne richiede la sostituzione ad HP, potrebbe dover sostenere spese addizionali a seconda del tipo di garanzia previsto per il prodotto.

³No: Non CSR—Alcuni componenti HP non sono progettati per la riparazione da parte del cliente. Per rispettare la garanzia, HP richiede che queste parti siano sostituite da un centro di assistenza autorizzato. Tali parti sono identificate da un "No" nel Catalogo illustrato dei componenti.

¹Mandatory: Zwingend—Teile, die im Rahmen des Customer Self Repair Programms ersetzt werden müssen. Wenn Sie diese Teile von HP ersetzen lassen, werden Ihnen die Versand- und Arbeitskosten für diesen Service berechnet.

²Optional: Optional—Teile, für die das Customer Self Repair-Verfahren optional ist. Diese Teile sind auch für Customer Self Repair ausgelegt. Wenn Sie jedoch den Austausch dieser Teile von HP vornehmen lassen möchten, können bei diesem Service je nach den für Ihr Produkt vorgesehenen Garantiebedingungen zusätzliche Kosten anfallen.

³No: Kein—Einige Teile sind nicht für Customer Self Repair ausgelegt. Um den Garantieanspruch des Kunden zu erfüllen, muss das Teil von einem HP Servicepartner ersetzt werden. Im illustrierten Teilekatalog sind diese Teile mit „No“ bzw. „Nein“ gekennzeichnet.

¹Mandatory: Obligatorio—componentes para los que la reparación por parte del usuario es obligatoria. Si solicita a HP que realice la sustitución de estos componentes, tendrá que hacerse cargo de los gastos de desplazamiento y de mano de obra de dicho servicio.

²Optional: Opcional— componentes para los que la reparación por parte del usuario es opcional. Estos componentes también están diseñados para que puedan ser reparados por el usuario. Sin embargo, si precisa que HP realice su sustitución, puede o no conllevar costes adicionales, dependiendo del tipo de servicio de garantía correspondiente al producto.

³No: No—Algunos componentes no están diseñados para que puedan ser reparados por el usuario. Para que el usuario haga valer su garantía, HP pone como condición que un proveedor de servicios autorizado realice la sustitución de estos componentes. Dichos componentes se identifican con la palabra "No" en el catálogo ilustrado de componentes.

¹Mandatory: Verplicht—Onderdelen waarvoor Customer Self Repair verplicht is. Als u HP verzoekt deze onderdelen te vervangen, komen de reiskosten en het arbeidsloon voor uw rekening.

²Optional: Optioneel—Onderdelen waarvoor reparatie door de klant optioneel is. Ook deze onderdelen zijn ontworpen voor reparatie door de klant. Als u echter HP verzoekt deze onderdelen voor u te vervangen, kunnen daarvoor extra kosten in rekening worden gebracht, afhankelijk van het type garantieservice voor het product.

³No: Nee—Sommige HP onderdelen zijn niet ontwikkeld voor reparatie door de klant. In verband met de garantievooraarden moet het onderdeel door een geautoriseerde Service Partner worden vervangen. Deze onderdelen worden in de geïllustreerde onderdelencatalogus aangemerkt met "Nee".

¹Mandatory: Obrigatória—Peças cujo reparo feito pelo cliente é obrigatório. Se desejar que a HP substitua essas peças, serão cobradas as despesas de transporte e mão-de-obra do serviço.

²Optional: Opcional—Peças cujo reparo feito pelo cliente é opcional. Essas peças também são projetadas para o reparo feito pelo cliente. No entanto, se desejar que a HP as substitua, pode haver ou não a cobrança de taxa adicional, dependendo do tipo de serviço de garantia destinado ao produto.

³No: Nenhuma—Algumas peças da HP não são projetadas para o reparo feito pelo cliente. A fim de cumprir a garantia do cliente, a HP exige que um técnico autorizado substitua a peça. Essas peças estão identificadas com a marca "No" (Não), no catálogo de peças ilustrado.

¹Mandatory : 必須 - 顧客自己修理が必須の部品。当該部品について、もしもお客様がHPに交換作業を依頼される場合には、その修理サービスに関する交通費および人件費がお客様に請求されます。

²Optional : 任意 - 顧客自己修理が任意である部品。この部品も顧客自己修理用です。当該部品について、もしもお客様がHPに交換作業を依頼される場合には、お買い上げの製品に適用される保証サービス内容の範囲内においては、費用を負担していただくことなく保証サービスを受けることができます。

³No : 除外 - HP製品の一部の部品は、顧客自己修理用ではありません。製品の保証を継続するためには、HPまたはHP正規保守代理店による交換作業が必須となります。部品カタログには、当該部品が顧客自己修理除外品である旨が記載されています。

¹Mandatory: 强制性的 — 要求客户必须自行维修的部件。如果您请求 HP 更换这些部件，则必须为该服务支付差旅费和人工费用。

²Optional: 可选的 — 客户可以选择是否自行维修的部件。这些部件也是为客户自行维修设计的。不过，如果您要求 HP 为您更换这些部件，则根据您的产品指定的保修服务类型，HP 可能收取或不再收取任何附加费用。

³No: 否 — 某些 HP 部件的设计并未考虑客户自行维修。为了满足客户保修的需要，HP 要求授权服务提供商更换相关部件。这些部件在部件图解目录中标记为“否”。

¹Mandatory: 強制的 — 客戶自行維修所使用的零件是強制性的。如果您要求 HP 更換這些零件，HP 將會向您收取此服務所需的外出費用與勞動成本。

²Optional: 選購的 — 客戶自行維修所使用的零件是選購的。這些零件也設計用於客戶自行維修之用。不過，如果您要求 HP 為您更換，則可能需要也可能不需要負擔額外的費用，端視針對此產品指定的保固服務類型而定。

³No: 否 — 某些 HP 零件沒有消費者可自行維修的設計。為符合客戶保固，HP 需要授權的服務供應商更換零件。這些零件在圖示的零件目錄中，被標示為「否」。

¹ Mandatory: 필수 — 고객 셀프 수리가 의무 사항인 필수 부품. 사용자가 HP에 이 부품의 교체를 요청할 경우 이 서비스에 대한 출장비 및 작업비가 청구됩니다.

² Optional: 옵션 — 고객 셀프 수리가 선택 사항인 부품. 이 부품들도 고객 셀프 수리가 가능하도록 설계되었습니다. 하지만 사용자가 HP에 이 부품의 교체를 요청할 경우 사용자가 구입한 제품에 해당하는 보증 서비스 유형에 따라 추가 비용 없이 교체가 가능할 수 있습니다.

³ No: No — 고객 셀프 수리가 불가능하도록 설계된 HP 부품. 이 부품들은 고객 셀프 수리가 불가능하도록 설계되었습니다. HP는 고객 보증을 만족시키기 위해 공인 서비스 제공업체를 통해 부품을 교체하도록 하고 있습니다.

System components

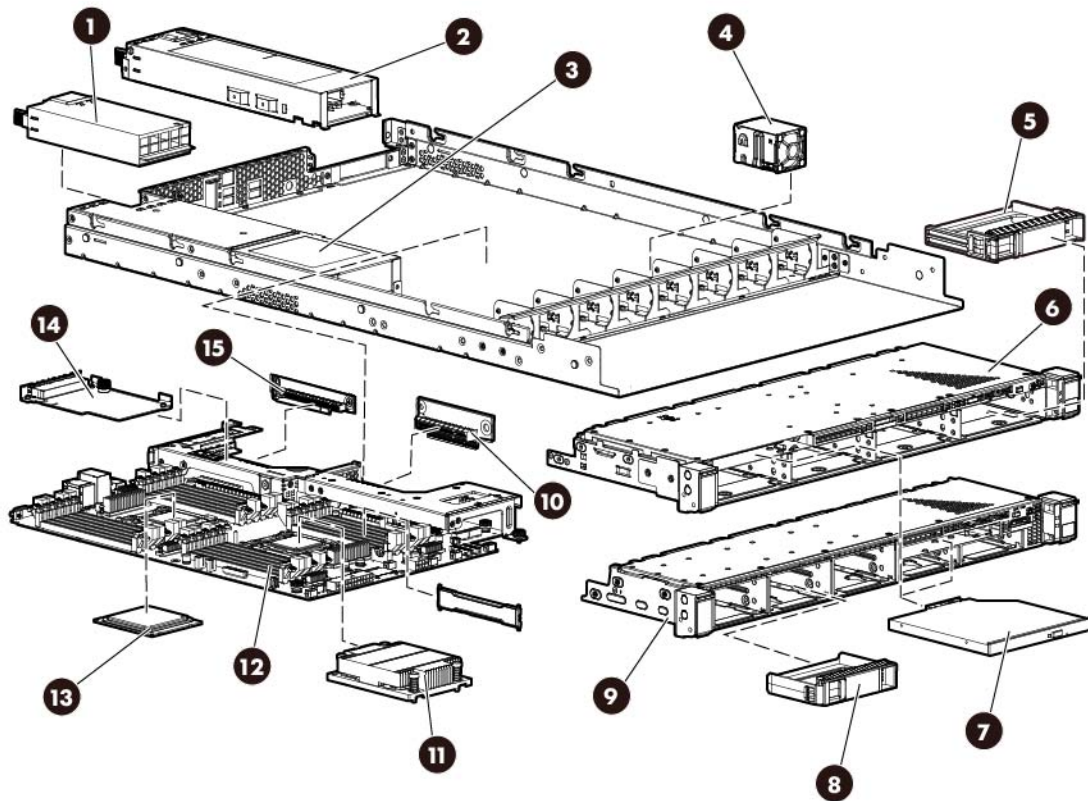

Item	Description	Spare part number	Customer self repair (on page 5)
1	Power supply module	—	—
	a) 460 W common slot power supply module	660184-001	Mandatory ¹
	b) 750 W common slot power supply module*	660183-001	Mandatory ¹
	c) 500 W Multioutput power supply module*	671797-001	Mandatory ¹
2	Multioutput power supply backplane	677054-001	Optional ²
3	Common slot power supply backplane	677053-001	Optional ²
4	Fan module	677059-001	Mandatory ¹
5	LFF drive blank	675039-001	Mandatory ¹
6	LFF drive cage assembly	683061-001	Mandatory ¹
7	DVD ROM drive	—	—
	a) SATA DVD-ROM drive, slimline	481428-001	Mandatory ¹
	b) SATA DVD-RW drive, slimline*	481429-001	Mandatory ¹
8	SFF drive blank	670033-001	Mandatory ¹
9	SFF drive cage assembly	683063-001	Mandatory ¹
10	PCIe riser x8	677052-001	Optional ²
11	Heatsink	—	—

Item	Description	Spare part number	Customer self repair (on page 5)
	a) Heatsink for processor 1	677055-001	Optional ²
	b) Heatsink for processor 2	677056-001	Optional ²
12	System board assembly	677046-001	Optional ²
13	Processor	—	—
	a) 1.8 GHz Intel® Xeon® processor E5-2603, 80 W* **	670533-001	Optional ²
	b) 2.00 GHz Intel® Xeon® processor E5-2620, 95 W* **	670529-001	Optional ²
	c) 2.5 GHz Intel® Xeon® processor E5-2640, 95 W* **	670527-001	Optional ²
	d) 2.3 GHz Intel® Xeon® processor E5-2530, 95W* **	670528-001	Optional ²
	e) 2 GHz Intel® Xeon® processor E5-2630L, 60W* **	670535-001	Optional ²
	f) 2.4 GHz Intel® Xeon® processor E5-2609, 80 W* **	670530-001	Optional ²
	g) 2.2 GHz Intel® Xeon® processor E5-2660, 95 W* **	670525-001	Optional ²
	h) 2.40 GHz Intel® Xeon® processor E5-2665, 115 W* **	670524-001	Optional ²
	i) 3.0 GHz Intel® Xeon® processor E5-2637, 80 W* **	670539-001	Optional ²
	j) 2.9 GHz Intel® Xeon® processor E5-2667, 130 W* **	670537-001	Optional ²
	k) 2.0 GHz Intel® Xeon® processor E5-2650, 95 W* **	670526-001	Optional ²
	l) 2.66 GHz Intel® Xeon® processor E5-2670, 115 W* **	670523-001	Optional ²
	m) 2.7 GHz Intel® Xeon® processor E5-2680, 130 W **	670522-001	Optional ²
	n) 1.80 GHz Intel® Xeon® processor E5-2650L, 70 W* **	670534-001	Optional ²
14	HP FlexibleLOM	—	—
	a) 1GB, 4 ports	634025-001	Optional ²
	b) 10 GB, 2 ports*	649869-001	Optional ²
	c) 10 GB, 2 ports*	634026-001	Optional ²
	d) 10 GB/40 GB, 2 ports*	656090-001	Optional ²
	e) 10 GB/40 GB, 2 ports*	656091-001	Optional ²
15	PCIe riser x16	677051-001	Optional ²
	Memory*	—	—
16	DIMM*	—	—
	a) 2 GB, PC3L-10600E-9, single-rank x8*	664694-001	Mandatory ¹
	b) 4 GB, PC3-12800R-11, single-rank x4*	664689-001	Mandatory ¹
	c) 4 GB, PC3L-10600R-9, single-rank x4*	664688-001	Mandatory ¹
	d) 4 GB, PC3L-10600E-9, dual-rank x8*	664695-001	Mandatory ¹
	e) 8 GB, PC3-12800R-1, single-rank x4*	664691-001	Mandatory ¹
	f) 8 GB, PC3L-10600R-9, dual-rank x4*	664690-001	Mandatory ¹
	g) 8 GB, PC3L-10600E-9, dual-rank x8*	664696-001	Mandatory ¹
	h) 16 GB, PC3L-10600R-9, dual-rank x4*	664692-001	Mandatory ¹

Item	Description	Spare part number	Customer self repair (on page 5)
17	Data drives*	—	—
	a) 600 GB, SAS, 15,000 rpm, 6G* (HDD)	418398-001	Mandatory ¹
	b) 600 GB, SAS, 10,000 rpm, 6G* (HDD)	512743-001	Mandatory ¹
	c) 450 GB, SAS, 15,000 rpm, 6G* (HDD)	418399-001	Mandatory ¹
	d) 300 GB, SAS, 10,000 rpm, 6G* (HDD)	507283-001	Mandatory ¹
	e) 300 GB, SAS, 15,000 rpm, 6G* (HDD)	504334-001	Mandatory ¹
	f) 400 GB, SATA, 2,500 rpm 3G* (SSD)	512744-001	Mandatory ¹
	g) 250 GB, SATA, 7,200 rpm, 3G* (HDD)	493083-001	Mandatory ¹
	h) 200 GB, SATA, 2,500 rpm, 3G* (SSD)	507284-001	Mandatory ¹
	i) 160 GB, SATA, 7,200 rpm, 3G* (HDD)	508009-001	Mandatory ¹
	j) 100 GB, SATA, 2,500 rpm, 3G* (HDD)	405419-001	Mandatory ¹
	k) 500 GB, SATA, 7,200 rpm 6G*(HDD)	459322-001	Mandatory ¹
	l) 3 TB, SATA, 7,200 rpm, 6G* (HDD)	460426-001	Mandatory ¹
18	HP Trusted Platform Module*	505836-001	No ³
	Miscellaneous	—	—
19	Battery, 3.3-V, lithium*	234556-001	Mandatory ¹
20	DIMM blank	689493-001	Mandatory ¹
	Cables	—	—
21	a) HP mini-SAS 700 mm Gen8 cable kit*	677068-001	Optional ²
	b) HP mini-SAS 560mm cable kit*	682626-001	Optional ²
	c) HP mini-SAS 390mm cable kit*	677067-001	Optional ²
	d) Front video adapter*	677064-001	Mandatory ¹
	e) SATA DVD-ROM drive cable*	683358-001	Optional ²
	f) VGA PSU cable*	677070-001	Optional ²
	g) Internal USB cable*	677066-001	Mandatory ¹

*Not shown

**All processors in this HP ProLiant server must have the same cache size, speed, number of cores, and rated maximum power consumption.

¹Mandatory—Parts for which customer self repair is mandatory. If you request HP to replace these parts, you will be charged for the travel and labor costs of this service.

²Optional—Parts for which customer self repair is optional. These parts are also designed for customer self repair. If, however, you require that HP replace them for you, there may or may not be additional charges, depending on the type of warranty service designated for your product.

³No—Some HP parts are not designed for customer self repair. In order to satisfy the customer warranty, HP requires that an authorized service provider replace the part. These parts are identified as "No" in the Illustrated Parts Catalog.

¹Mandatory: Obligatoire—Pièces pour lesquelles la réparation par le client est obligatoire. Si vous demandez à HP de remplacer ces pièces, les coûts de déplacement et main d'œuvre du service vous seront facturés.

²Optional: Facultatif—Pièces pour lesquelles la réparation par le client est facultative. Ces pièces sont également conçues pour permettre au client d'effectuer lui-même la réparation. Toutefois, si vous demandez à HP de remplacer ces pièces, l'intervention peut ou non vous être facturée, selon le type de garantie applicable à votre produit.

³No: Non—Certaines pièces HP ne sont pas conçues pour permettre au client d'effectuer lui-même la réparation. Pour que la garantie puisse s'appliquer, HP exige que le remplacement de la pièce soit effectué par un Mainteneur Agréé. Ces pièces sont identifiées par la mention "Non" dans le Catalogue illustré.

¹Mandatory: Obbligatorie—Parti che devono essere necessariamente riparate dal cliente. Se il cliente ne affida la riparazione ad HP, deve sostenere le spese di spedizione e di manodopera per il servizio.

²Optional: Opzionali—Parti la cui riparazione da parte del cliente è facoltativa. Si tratta comunque di componenti progettati per questo scopo. Se tuttavia il cliente ne richiede la sostituzione ad HP, potrebbe dover sostenere spese aggiuntive a seconda del tipo di garanzia previsto per il prodotto.

³No: Non CSR—Alcuni componenti HP non sono progettati per la riparazione da parte del cliente. Per rispettare la garanzia, HP richiede che queste parti siano sostituite da un centro di assistenza autorizzato. Tali parti sono identificate da un "No" nel Catalogo illustrato dei componenti.

¹Mandatory: Zwingend—Teile, die im Rahmen des Customer Self Repair Programms ersetzt werden müssen. Wenn Sie diese Teile von HP ersetzen lassen, werden Ihnen die Versand- und Arbeitskosten für diesen Service berechnet.

²Optional: Optional—Teile, für die das Customer Self Repair-Verfahren optional ist. Diese Teile sind auch für Customer Self Repair ausgelegt. Wenn Sie jedoch den Austausch dieser Teile von HP vornehmen lassen möchten, können bei diesem Service je nach den für Ihr Produkt vorgesehenen Garantiebedingungen zusätzliche Kosten anfallen.

³No: Kein—Einige Teile sind nicht für Customer Self Repair ausgelegt. Um den Garantieanspruch des Kunden zu erfüllen, muss das Teil von einem HP Servicepartner ersetzt werden. Im illustrierten Teilekatalog sind diese Teile mit „No“ bzw. „Nein“ gekennzeichnet.

¹Mandatory: Obligatorio—componentes para los que la reparación por parte del usuario es obligatoria. Si solicita a HP que realice la sustitución de estos componentes, tendrá que hacerse cargo de los gastos de desplazamiento y de mano de obra de dicho servicio.

²Optional: Opcional— componentes para los que la reparación por parte del usuario es opcional. Estos componentes también están diseñados para que puedan ser reparados por el usuario. Sin embargo, si precisa que HP realice su sustitución, puede o no conllevar costes adicionales, dependiendo del tipo de servicio de garantía correspondiente al producto.

³No: No—Algunos componentes no están diseñados para que puedan ser reparados por el usuario. Para que el usuario haga valer su garantía, HP pone como condición que un proveedor de servicios autorizado realice la sustitución de estos componentes. Dichos componentes se identifican con la palabra "No" en el catálogo ilustrado de componentes.

¹Mandatory: Verplicht—Onderdelen waarvoor Customer Self Repair verplicht is. Als u HP verzoekt deze onderdelen te vervangen, komen de reiskosten en het arbeidsloon voor uw rekening.

²Optional: Optioneel—Onderdelen waarvoor reparatie door de klant optioneel is. Ook deze onderdelen zijn ontworpen voor reparatie door de klant. Als u echter HP verzoekt deze onderdelen voor u te vervangen, kunnen daarvoor extra kosten in rekening worden gebracht, afhankelijk van het type garantieservice voor het product.

³No: Nee—Sommige HP onderdelen zijn niet ontwikkeld voor reparatie door de klant. In verband met de garantievoorwaarden moet het onderdeel door een geautoriseerde Service Partner worden vervangen. Deze onderdelen worden in de geïllustreerde onderdelencatalogus aangemerkt met "Nee".

¹Mandatory: Obrigatória—Peças cujo reparo feito pelo cliente é obrigatório. Se desejar que a HP substitua essas peças, serão cobradas as despesas de transporte e mão-de-obra do serviço.

²Optional: Opcional—Peças cujo reparo feito pelo cliente é opcional. Essas peças também são projetadas para o reparo feito pelo cliente. No entanto, se desejar que a HP as substitua, pode haver ou não a cobrança de taxa adicional, dependendo do tipo de serviço de garantia destinado ao produto.

³No: Nenhuma—Algumas peças da HP não são projetadas para o reparo feito pelo cliente. A fim de cumprir a garantia do cliente, a HP exige que um técnico autorizado substitua a peça. Essas peças estão identificadas com a marca "No" (Não), no catálogo de peças ilustrado.

¹Mandatory : 必須 - 顧客自己修理が必須の部品。当該部品について、もしもお客様がHPに交換作業を依頼される場合には、その修理サービスに関する交通費および人件費がお客様に請求されます。

²Optional : 任意 - 顧客自己修理が任意である部品。この部品も顧客自己修理用です。当該部品について、もしもお客様がHPに交換作業を依頼される場合には、お買い上げの製品に適用される保証サービス内容の範囲内においては、費用を負担していただくことなく保証サービスを受けることができます。

³No : 除外 - HP製品の一部の部品は、顧客自己修理用ではありません。製品の保証を継続するためには、HPまたはHP正規保守代理店による交換作業が必須となります。部品カタログには、当該部品が顧客自己修理除外品である旨が記載されています。

¹Mandatory: 强制性的 — 要求客户必须自行维修的部件。如果您请求 HP 更换这些部件，则必须为该服务支付差旅费和人工费用。

²Optional: 可选的 — 客户可以选择是否自行维修的部件。这些部件也是为客户自行维修设计的。不过，如果您要求 HP 为您更换这些部件，则根据您的产品指定的保修服务类型，HP 可能收取或不再收取任何附加费用。

³No: 否 — 某些 HP 部件的设计并未考虑客户自行维修。为了满足客户保修的需要，HP 要求授权服务提供商更换相关部件。这些部件在部件图解目录中标记为“否”。

¹Mandatory: 強制的 — 客戶自行維修所使用的零件是強制性的。如果您要求 HP 更換這些零件，HP 將會向您收取此服務所需的外出費用與勞動成本。

²Optional: 選購的 — 客戶自行維修所使用的零件是選購的。這些零件也設計用於客戶自行維修之用。不過，如果您要求 HP 為您更換，則可能需要也可能不需要負擔額外的費用，端視針對此產品指定的保固服務類型而定。

³No: 否 — 某些 HP 零件沒有消費者可自行維修的設計。為符合客戶保固，HP 需要授權的服務供應商更換零件。這些零件在圖示的零件目錄中，被標示為「否」。

¹ Mandatory: 필수 — 고객 셀프 수리가 의무 사항인 필수 부품. 사용자가 HP에 이 부품의 교체를 요청할 경우 이 서비스에 대한 출장비 및 작업비가 청구됩니다.

² Optional: 옵션 — 고객 셀프 수리가 선택 사항인 부품. 이 부품들도 고객 셀프 수리가 가능하도록 설계되었습니다. 하지만 사용자가 HP에 이 부품의 교체를 요청할 경우 사용자가 구입한 제품에 해당하는 보증 서비스 유형에 따라 추가 비용 없이 교체가 가능할 수 있습니다.

³ No: No — 고객 셀프 수리가 불가능하도록 설계된 HP 부품. 이 부품들은 고객 셀프 수리가 불가능하도록 설계되었습니다. HP는 고객 보증을 만족시키기 위해 공인 서비스 제공업체를 통해 부품을 교체하도록 하고 있습니다.

Removal and replacement procedures

Required tools

You need the following items for some procedures:

- T-10/T-15 Torx screwdriver (provided inside the server)
- HP Insight Diagnostics software ("HP Insight Diagnostics" on page 69)

Safety considerations

Before performing service procedures, review all the safety information.

Preventing electrostatic discharge

To prevent damaging the system, be aware of the precautions you need to follow when setting up the system or handling parts. A discharge of static electricity from a finger or other conductor may damage system boards or other static-sensitive devices. This type of damage may reduce the life expectancy of the device.

To prevent electrostatic damage:

- Avoid hand contact by transporting and storing products in static-safe containers.
- Keep electrostatic-sensitive parts in their containers until they arrive at static-free workstations.
- Place parts on a grounded surface before removing them from their containers.
- Avoid touching pins, leads, or circuitry.
- Always be properly grounded when touching a static-sensitive component or assembly.

Symbols on equipment

The following symbols may be placed on equipment to indicate the presence of potentially hazardous conditions.



This symbol indicates the presence of hazardous energy circuits or electric shock hazards. Refer all servicing to qualified personnel.

WARNING: To reduce the risk of injury from electric shock hazards, do not open this enclosure. Refer all maintenance, upgrades, and servicing to qualified personnel.



This symbol indicates the presence of electric shock hazards. The area contains no user or field serviceable parts. Do not open for any reason.

WARNING: To reduce the risk of injury from electric shock hazards, do not open this enclosure.



This symbol on an RJ-45 receptacle indicates a network interface connection.

WARNING: To reduce the risk of electric shock, fire, or damage to the equipment, do not plug telephone or telecommunications connectors into this receptacle.

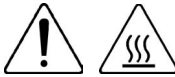

This symbol indicates the presence of a hot surface or hot component. If this surface is contacted, the potential for injury exists.

WARNING: To reduce the risk of injury from a hot component, allow the surface to cool before touching.



This symbol indicates that the component exceeds the recommended weight for one individual to handle safely.

WARNING: To reduce the risk of personal injury or damage to the equipment, observe local occupational health and safety requirements and guidelines for manual material handling.



These symbols, on power supplies or systems, indicate that the equipment is supplied by multiple sources of power.

WARNING: To reduce the risk of injury from electric shock, remove all power cords to completely disconnect power from the system.

Server warnings and cautions

Before installing a server, be sure that you understand the following warnings and cautions.



WARNING: To reduce the risk of electric shock or damage to the equipment:

- Do not disable the power cord grounding plug. The grounding plug is an important safety feature.
- Plug the power cord into a grounded (earthed) electrical outlet that is easily accessible at all times.
- Unplug the power cord from the power supply to disconnect power to the equipment.
- Do not route the power cord where it can be walked on or pinched by items placed against it. Pay particular attention to the plug, electrical outlet, and the point where the cord extends from the server.



WARNING: To reduce the risk of personal injury from hot surfaces, allow the drives and the internal system components to cool before touching them.



CAUTION: Do not operate the server for long periods with the access panel open or removed. Operating the server in this manner results in improper airflow and improper cooling that can lead to thermal damage.

Preparation procedures

To access some components and perform certain service procedures, you must perform one or more of the following procedures:

- Extend the server from the rack (on page 26).

If you are performing service procedures in an HP, Compaq branded, telco, or third-party rack cabinet, you can use the locking feature of the rack rails to support the server and gain access to internal components.

For more information about telco rack solutions, refer to the RackSolutions.com website (<http://www.racksolutions.com/hp>).

- Power down the server (on page 26).

If you must remove a server from a rack or a non-hot-plug component from a server, power down the server.

- Remove the server from the rack (on page 27).

If the rack environment, cabling configuration, or the server location in the rack creates awkward conditions, remove the server from the rack.

Power down the server

Before powering down the server for any upgrade or maintenance procedures, perform a backup of critical server data and programs.



IMPORTANT: When the server is in standby mode, auxiliary power is still being provided to the system.

To power down the server, use one of the following methods:

- Press and release the Power On/Standby button.
This method initiates a controlled shutdown of applications and the OS before the server enters standby mode.
- Press and hold the Power On/Standby button for more than 4 seconds to force the server to enter standby mode.
This method forces the server to enter standby mode without properly exiting applications and the OS. If an application stops responding, you can use this method to force a shutdown.
- Use a virtual power button selection through iLO 3.
This method initiates a controlled remote shutdown of applications and the OS before the server enters standby mode.

Before proceeding, verify the server is in standby mode by observing that the system power LED is amber.

Extend the server from the rack

1. Pull down the quick release levers on each side of the server.

NOTE: If the server does not extend from the rack, pull down each quick release lever and use a T-20 screwdriver to loosen the screws located within the lever housing.

2. Extend the server from the rack.



WARNING: To reduce the risk of personal injury or equipment damage, be sure that the rack is adequately stabilized before extending a component from the rack.

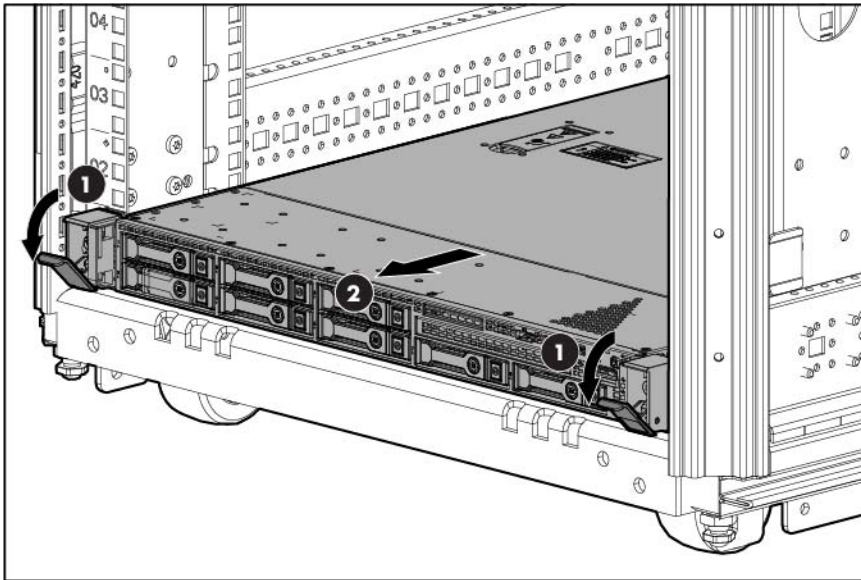

3. After performing the installation or maintenance procedure, slide the server back into the rack, and then press the server firmly into the rack to secure it in place.

⚠ WARNING: To reduce the risk of personal injury, be careful when pressing the server rail-release latches and sliding the server into the rack. The sliding rails could pinch your fingers.

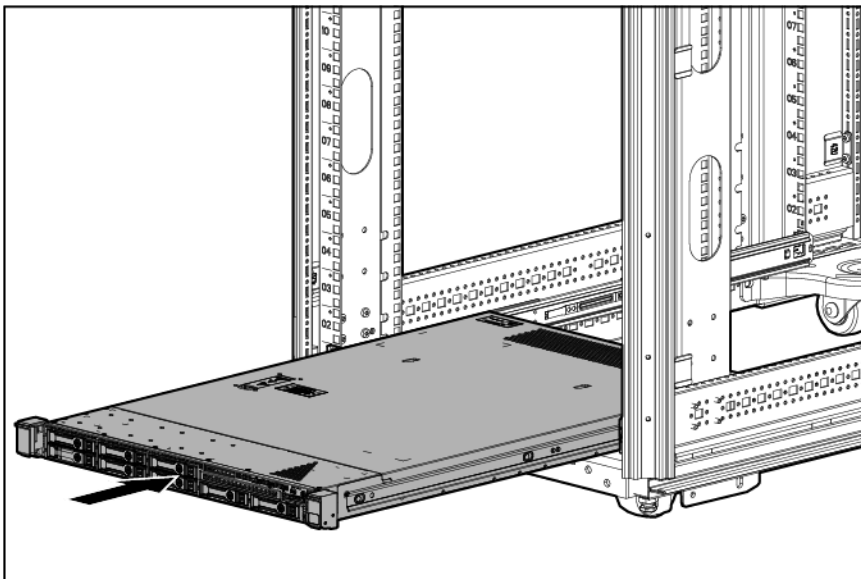

Remove the server from the rack

To remove the server from an HP, Compaq branded, Telco, or third-party rack:

1. If installed, remove the rack bezel ("[Rack bezel](#)" on page [28](#)).
2. Power down the server (on page [26](#)).
3. Remove all power:
 - a. Disconnect each power cord from the power source.
 - b. Disconnect each power cord from the server.

4. Extend the server from the rack (on page 26).
5. Release the locking latches.
6. Disconnect the cabling, and then remove the server from the rack. For more information, see the documentation that ships with the rack mounting option.
7. Place the server on a sturdy, level surface.

Access panel



WARNING: To reduce the risk of personal injury from hot surfaces, allow the drives and the internal system components to cool before touching them.



CAUTION: Do not operate the server for long periods with the access panel open or removed. Operating the server in this manner results in improper airflow and improper cooling that can lead to thermal damage.

To remove the component:

1. If installed, remove the rack bezel ("Rack bezel" on page 28).
2. Power down the server (on page 26).
3. Remove all power:
 - a. Disconnect each power cord from the power source.
 - b. Disconnect each power cord from the server.
4. Extend the server from the rack (on page 26).
5. Open the locking latch, slide the access panel to the rear of the chassis, and then remove the access panel.

If the locking latch is locked use a T-15 Torx screwdriver to unlock it.

Rack bezel

Unlock the rack bezel, press the latch on the rack bezel, and then remove the rack bezel.

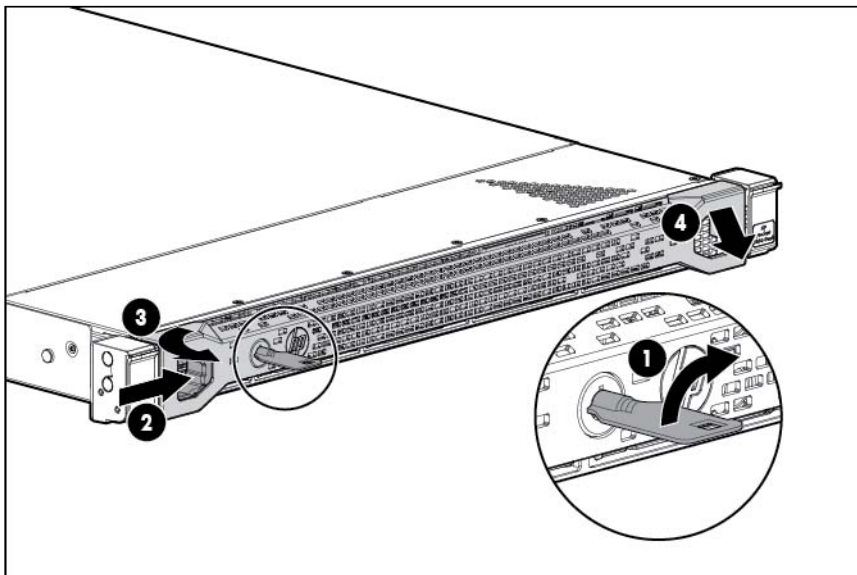

Power supply module

- ⚠ CAUTION:** To prevent improper cooling and thermal damage, do not operate the server unless all bays are populated with either a component or a blank.

To remove the component:

1. If installed, remove the rack bezel ("[Rack bezel](#)" on page 28).
2. Power down the server (on page 26).
3. Remove all power:
 - a. Disconnect each power cord from the power source.
 - b. Disconnect each power cord from the server.
4. Access the product rear panel.
5. Remove the power supply module.

- ⚠ WARNING:** To reduce the risk of personal injury from hot surfaces, allow the power supply or power supply blank to cool before touching it.

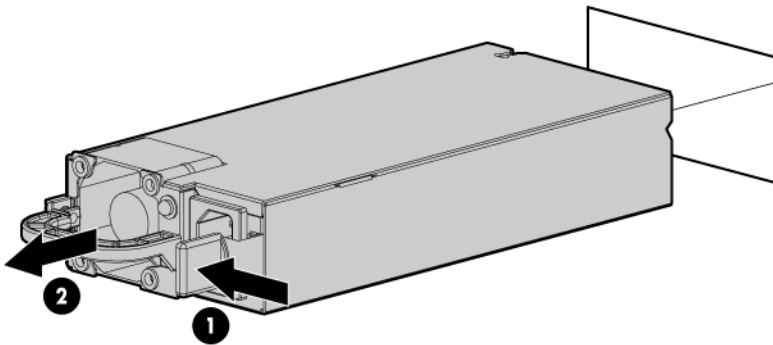

To replace the component, reverse the removal procedure.

Multioutput power supply backplane

To remove the component:

1. If installed, remove the rack bezel ("[Rack bezel](#)" on page 28).
2. Power down the server (on page 26).
3. Remove all power:
 - a. Disconnect each power cord from the power source.
 - b. Disconnect each power cord from the server.
4. Extend the server from the rack (on page 26).
5. Remove the access panel ("[Access panel](#)" on page 28).
6. Remove the processor air baffle ("[Processor air baffle](#)" on page 41).

7. Remove the PCI riser cage ("PCI riser cage" on page 42).
8. Remove the fan cables, front IO (Input/Output) cables, FBWC cable, power supply cables, and mini-SAS cables.
9. Remove the system board tray:
 - a. Loosen the two thumbscrews.
 - b. Lift the tray out of the chassis.

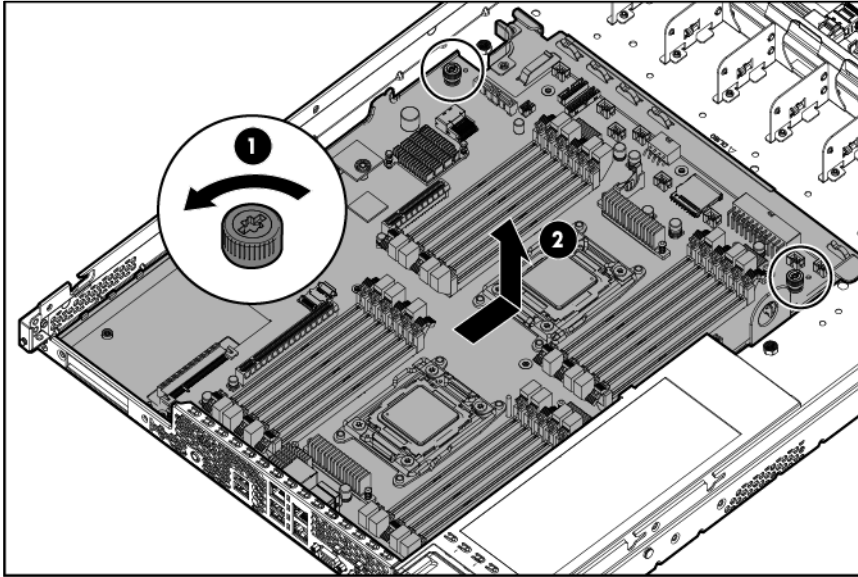

10. Remove the power supply module ("Power supply module" on page 29).
11. Remove the failed power supply backplane.

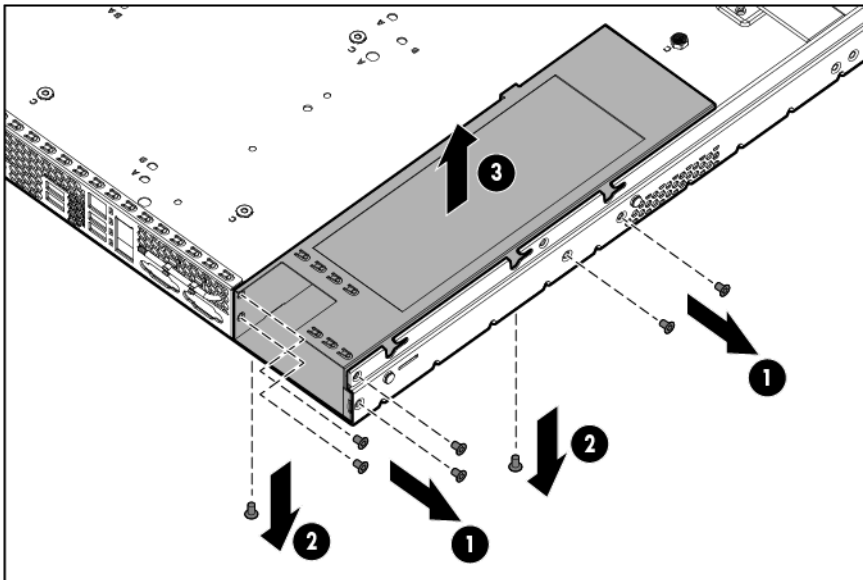

To replace the component, reverse the removal procedure.

Common slot power supply backplane

To remove the component:

1. If installed, remove the rack bezel ("[Rack bezel](#)" on page 28).
2. Power down the server (on page 26).
3. Remove all power:
 - a. Disconnect each power cord from the power source.
 - b. Disconnect each power cord from the server.
4. Extend the server from the rack (on page 26).
5. Remove the access panel ("[Access panel](#)" on page 28).
6. Remove the processor air baffle ("[Processor air baffle](#)" on page 41).
7. Remove the PCI riser cage ("[PCI riser cage](#)" on page 42).
8. Remove the fan cables, front IO (Input/Output) cables, FBWC cable, power supply cables, and mini-SAS cables.
9. Remove the system board tray:
 - a. Loosen the two thumbscrews.
 - b. Lift the tray out of the chassis.

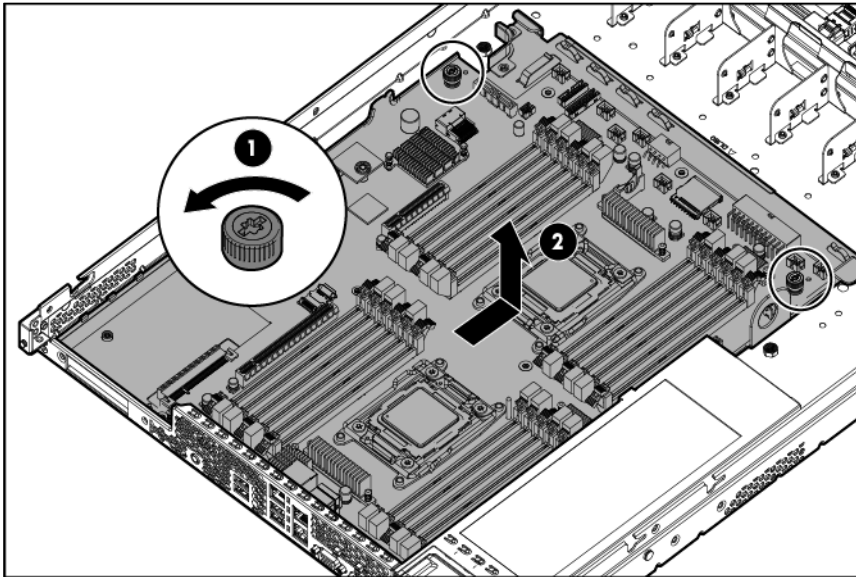

10. Remove the power supply module ("[Power supply module](#)" on page 29).

11. Remove the common slot power supply cage.

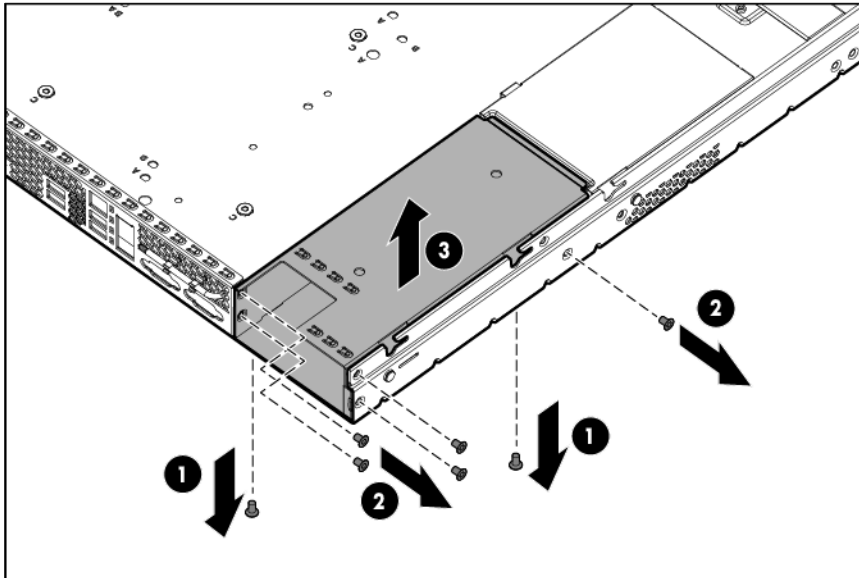

12. Remove the common slot power supply backplane.

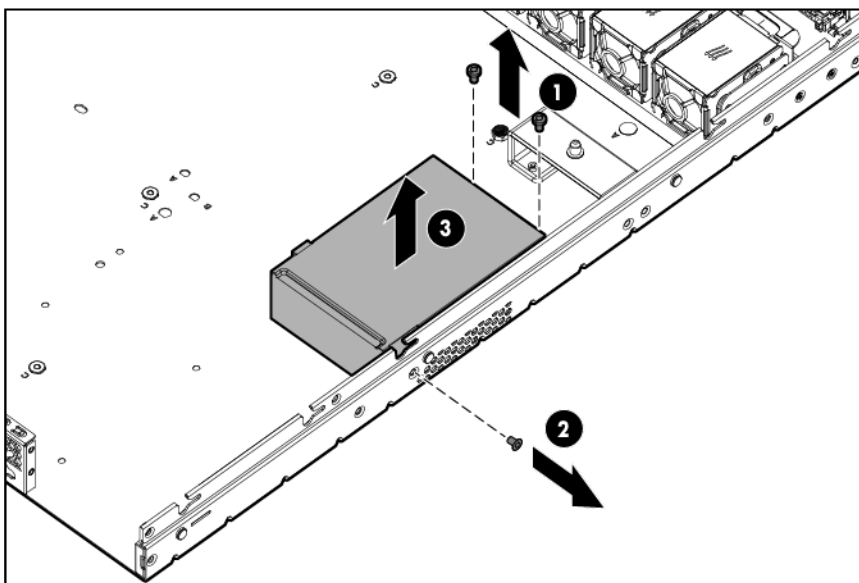

To replace the component, reverse the removal procedure.

DVD-ROM or DVD-RW drive

To remove the component:

1. If installed, remove the rack bezel ("Rack bezel" on page 28).
2. Power down the server (on page 26).
3. Remove all power:
 - a. Disconnect each power cord from the power source.
 - b. Disconnect each power cord from the server.
4. Extend the server from the rack (on page 26).

5. Remove the access panel ("Access panel" on page 28).
6. Remove the processor air baffle ("Processor air baffle" on page 41).
7. Remove the PCI riser cage ("PCI riser cage" on page 42).
8. Disconnect the SATA DVD cable from the rear of the DVD drive.
9. Remove the DVD drive.

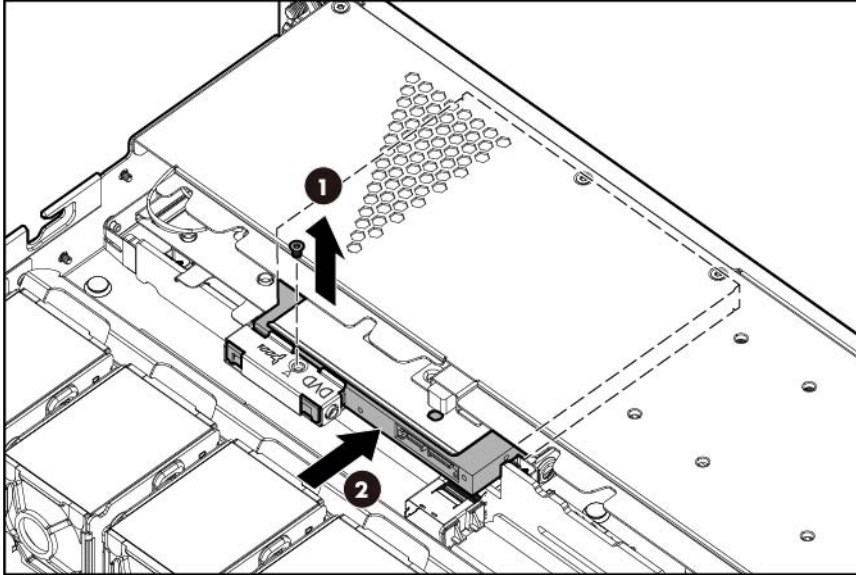

To replace the component, reverse the removal procedure.

Drive blank

Remove the component as indicated.

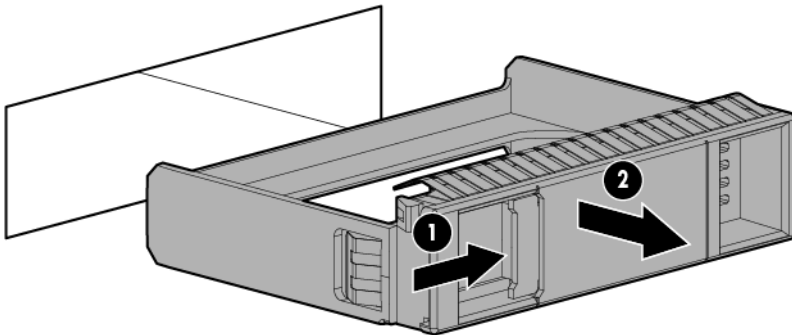

To replace the blank, slide the blank into the bay until it locks into place.

Hot-plug drive



CAUTION: For proper cooling do not operate the server without the access panel, baffles, expansion slot covers, or blanks installed. If the server supports hot-plug components, minimize the amount of time the access panel is open.

1. Determine the status of the drive from the hot-plug drive LED definitions ("[Drive LED definitions](#)" on page 79).
2. Back up all server data on the drive.
3. Remove the drive.

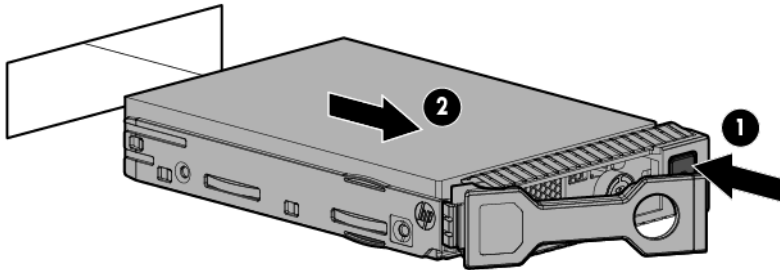

To replace the component, reverse the removal procedure.

Fan blank

When one processor is installed, install fan blanks in slots 2 and 5. When two processors are installed, install fans in these slots.

To remove the component:

1. If installed, remove the rack bezel ("[Rack bezel](#)" on page 28).
2. Power down the server (on page 26).
3. Remove all power:
 - a. Disconnect each power cord from the power source.
 - b. Disconnect each power cord from the server.
4. Extend the server from the rack (on page 26).
5. Remove the access panel ("[Access panel](#)" on page 28).

6. Remove the fan blanks.

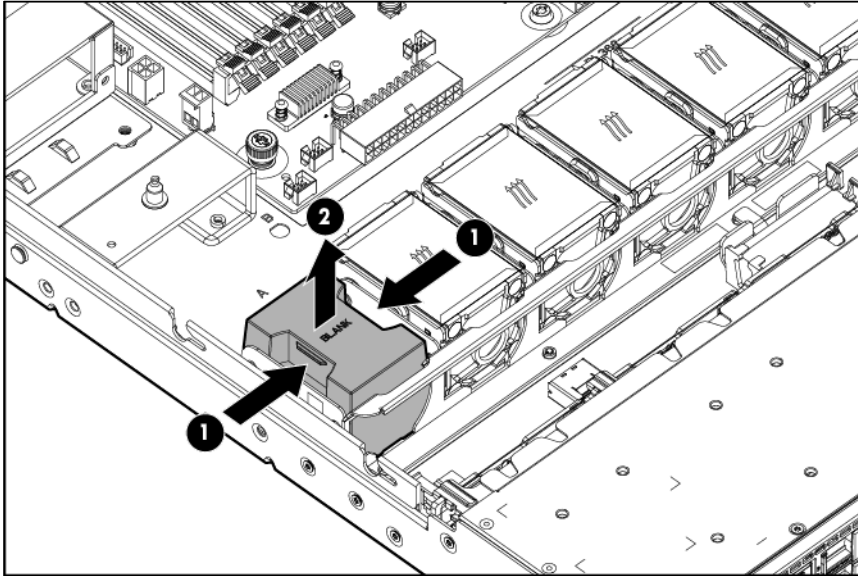

To replace the component, reverse the removal procedure.

Fan module

When one processor is installed, install fan blanks in slots 2 and 5. When two processors are installed, install fans in these slots.

To remove a fan module:

1. If installed, remove the rack bezel ("[Rack bezel](#)" on page [28](#)).
2. Power down the server (on page [26](#)).
3. Remove all power:
 - a. Disconnect each power cord from the power source.
 - b. Disconnect each power cord from the server.
4. Extend the server from the rack (on page [26](#)).
5. Remove the access panel ("[Access panel](#)" on page [28](#)).

6. Disconnect the fan cable from the system board, and then remove the fan module.

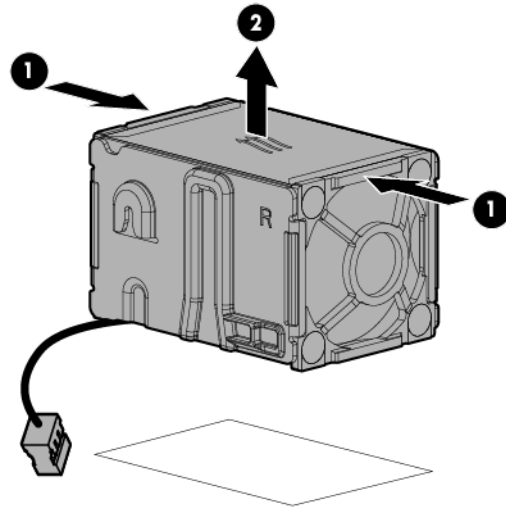

To replace the component:

1. Install the fan module, and then connect the fan cable to the system board.

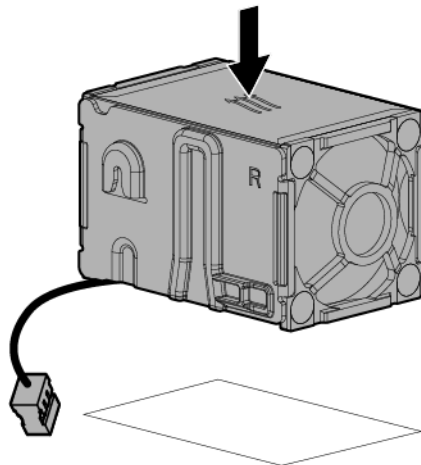

2. Install the access panel.
3. Slide the server into the rack.
4. Connect each power cord to the server.
5. Connect each power cord to the power source.
6. Power up the server.
7. If removed, install the rack bezel.

Front video adapter

Remove the component as indicated.

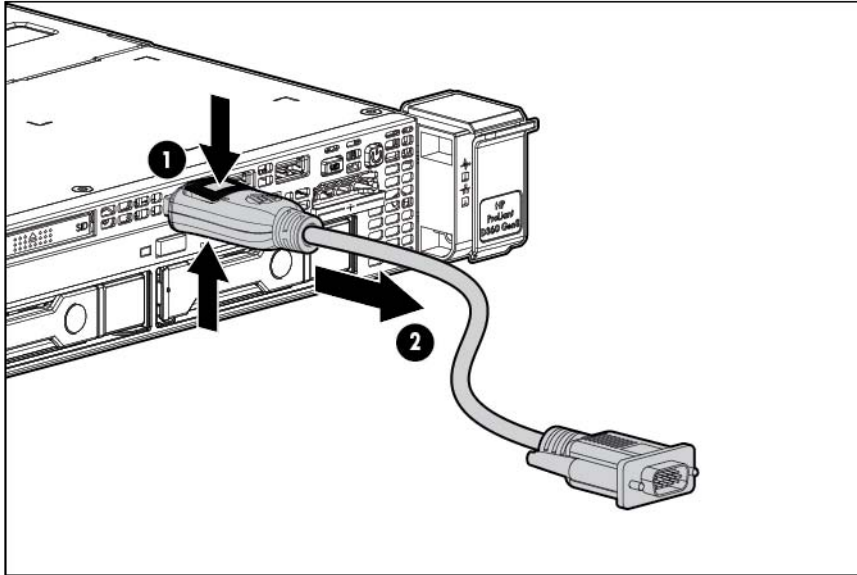

CAUTION: Be sure to connect the video adapter to the video connector, and not to the USB connector.

To replace the component, reverse the removal procedure.

FlexibleLOM option



WARNING: To reduce the risk of personal injury, electric shock, or damage to the equipment, remove the power cord to remove power from the server. The front panel Power On/Standby button does not completely shut off system power. Portions of the power supply and some internal circuitry remain active until AC power is removed.

1. If installed, remove the rack bezel ("[Rack bezel](#)" on page 28).
2. Power down the server (on page 26).
3. Remove all power:
 - a. Disconnect each power cord from the power source.
 - b. Disconnect each power cord from the server.
4. Remove any attached network cables.
5. Extend the server from the rack (on page 26).
6. Remove the access panel ("[Access panel](#)" on page 28).
7. Remove the processor air baffle ("[Processor air baffle](#)" on page 41).
8. Remove the PCI riser cage ("[PCI riser cage](#)" on page 42).
9. Loosen the thumbscrew on the FlexibleLOM.

10. Remove the existing FlexibleLOM.

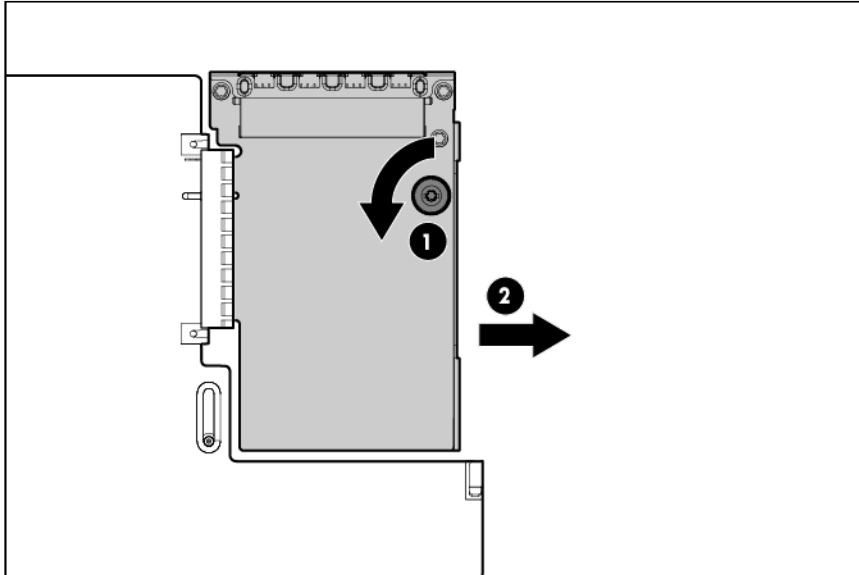

To replace the component:

1. Firmly seat the FlexibleLOM in the slot, and then tighten the thumbscrew.

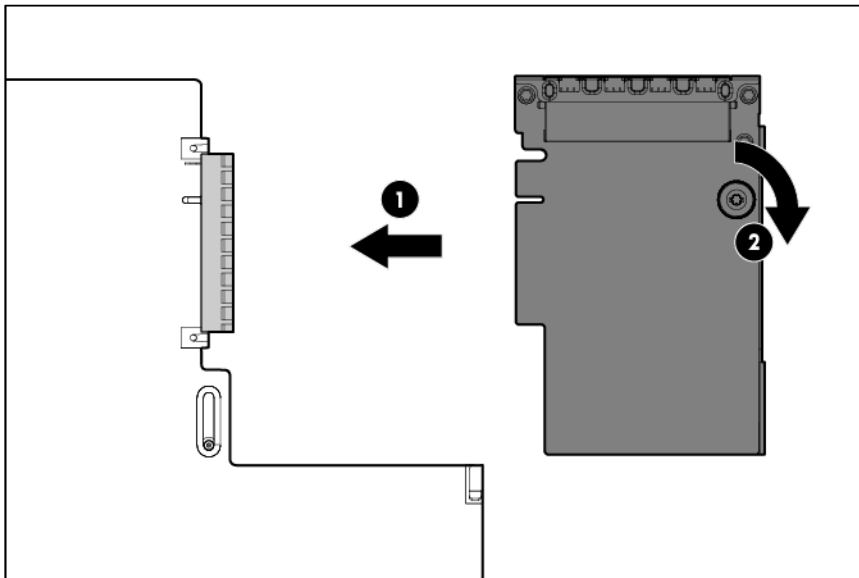

2. Install the PCI riser cage.
3. Install the processor air baffle.
4. Install the access panel.
5. Slide the server into the rack.
6. Connect the LAN segment cables.
7. Connect each power cord to the server.
8. Connect each power cord to the power source.
9. Power up the server.
10. If removed, install the rack bezel.

LFF drive cage assembly

The drive cage assembly includes the front panel LEDs and buttons (on page 74), drive backplane, and cables.

To remove the component:

1. If installed, remove the rack bezel ("[Rack bezel](#)" on page 28).
2. Power down the server (on page 26).
3. Remove all power:
 - a. Disconnect each power cord from the power source.
 - b. Disconnect each power cord from the server.
4. Extend the server from the rack (on page 26).
5. Remove the access panel ("[Access panel](#)" on page 28).
6. Remove the processor air baffle ("[Processor air baffle](#)" on page 41).
7. Remove all hot-plug drives ("[Hot-plug drive](#)" on page 33).
8. Disconnect the power and data cables from the drive backplane.

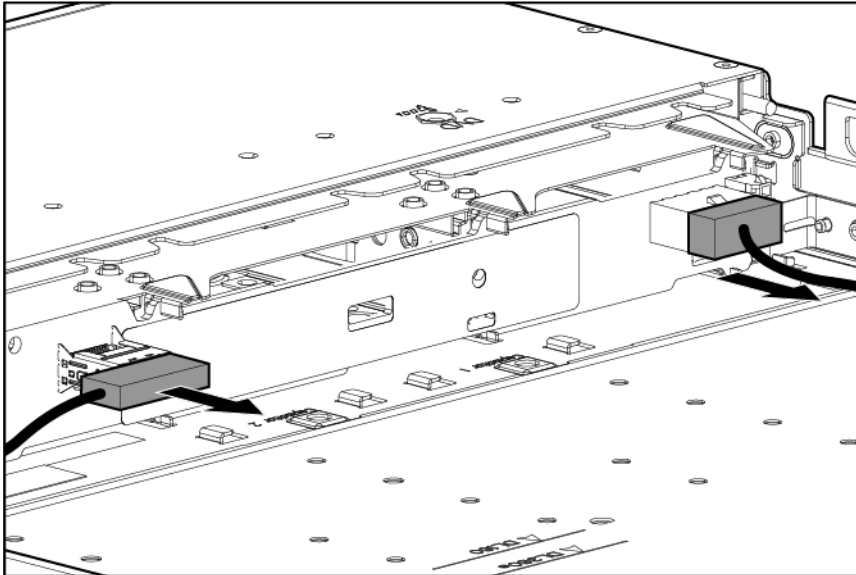

9. Remove the drive cage assembly.

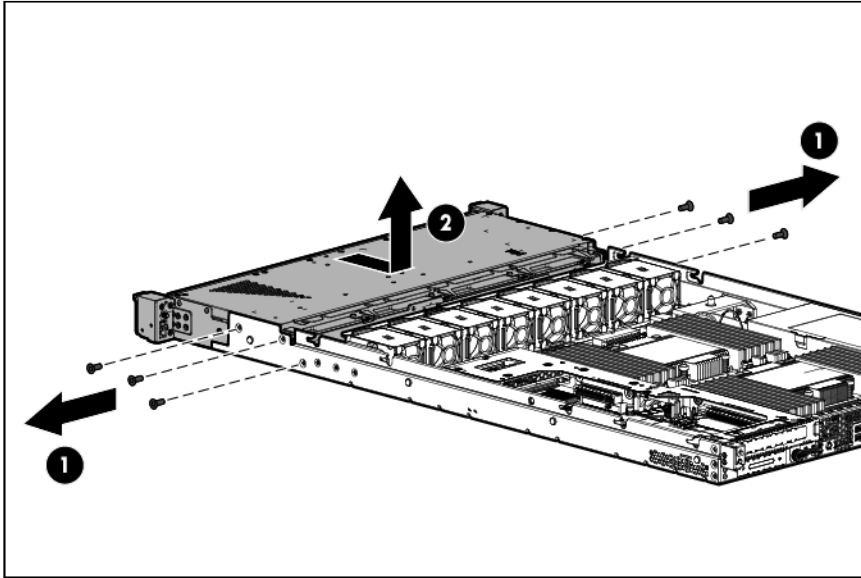

To replace the component, reverse the removal procedure.

SFF drive cage assembly

The drive cage assembly includes the front panel LEDs and buttons (on page 74), drive backplane, and cables.

To remove the component:

1. If installed, remove the rack bezel ("[Rack bezel](#)" on page 28).
2. Power down the server (on page 26).
3. Remove all power:
 - a. Disconnect each power cord from the power source.
 - b. Disconnect each power cord from the server.
4. Extend the server from the rack (on page 26).
5. Remove the access panel ("[Access panel](#)" on page 28).
6. Remove the processor air baffle ("[Processor air baffle](#)" on page 41).
7. Remove all hot-plug drives ("[Hot-plug drive](#)" on page 33).

8. Disconnect the power cables and data cables from the drive backplane.

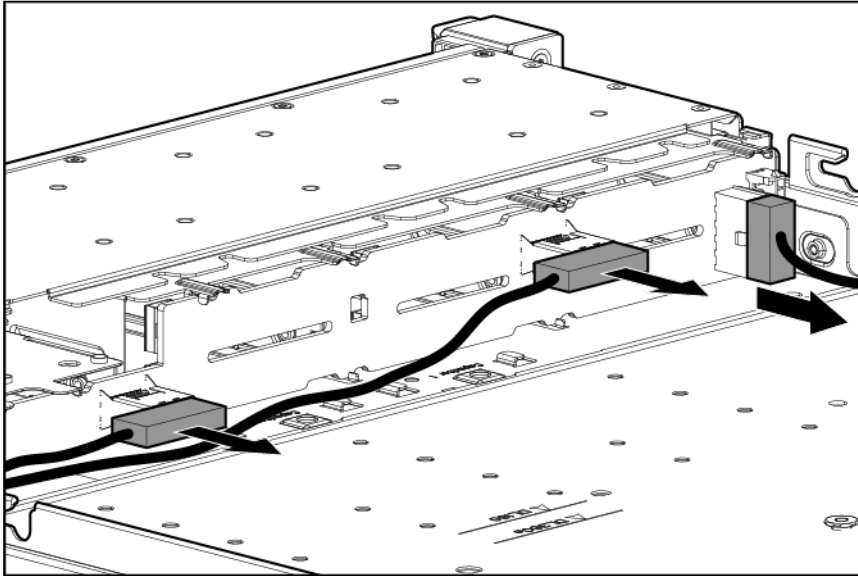

9. Remove the drive cage assembly.

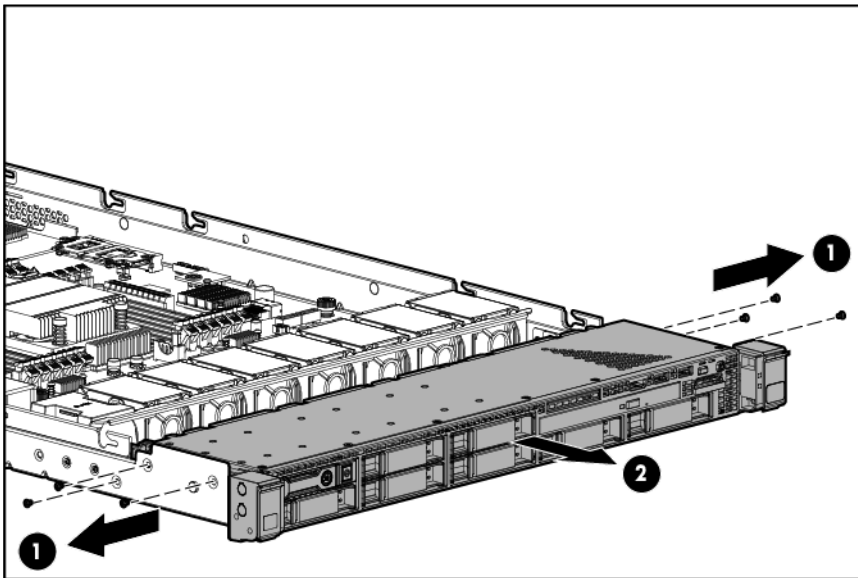

To replace the component, reverse the removal procedure.

Processor air baffle

To remove the component:

1. If installed, remove the rack bezel ("[Rack bezel](#)" on page [28](#)).
2. Power down the server (on page [26](#)).
3. Remove all power:
 - a. Disconnect each power cord from the power source.
 - b. Disconnect each power cord from the server.
4. Extend the server from the rack (on page [26](#)).

5. Remove the access panel ("Access panel" on page 28).
6. Remove the processor air baffle.

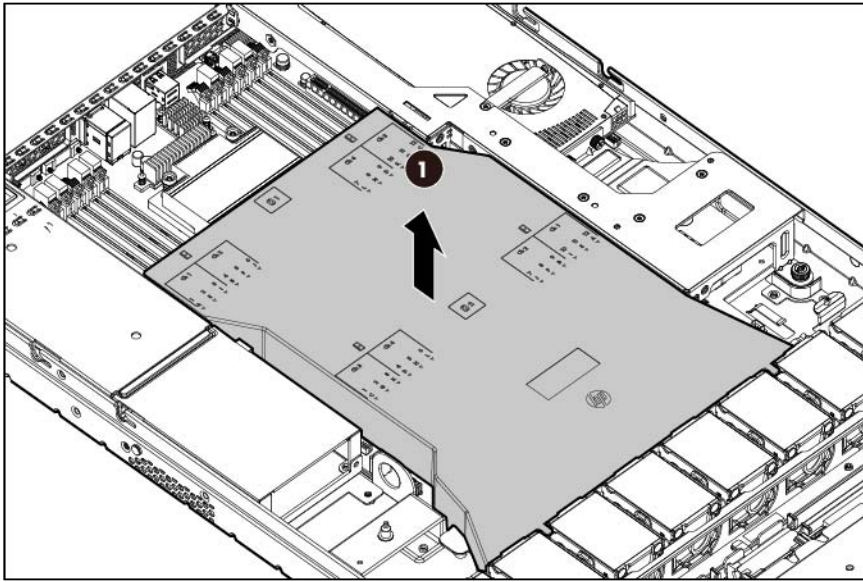

To replace the component, reverse the removal procedure.

PCI riser cage

To remove the component:

⚠ CAUTION: To prevent damage to the server or expansion boards, power down the server and remove all AC power cords before removing or installing the PCI riser board assembly.

1. If installed, remove the rack bezel ("Rack bezel" on page 28).
2. Power down the server (on page 26).
3. Remove all power:
 - a. Disconnect each power cord from the power source.
 - b. Disconnect each power cord from the server.
4. Extend the server from the rack (on page 26).
5. Remove the access panel ("Access panel" on page 28).
6. Remove the processor air baffle ("Processor air baffle" on page 41).
7. Disconnect external cables connected to any existing expansion boards.
8. Remove the PCI riser cage:
 - a. Unfasten the three screws in the PCI riser cage.

- b. To unseat the PCI riser boards, lift the assembly, and then remove the cage.

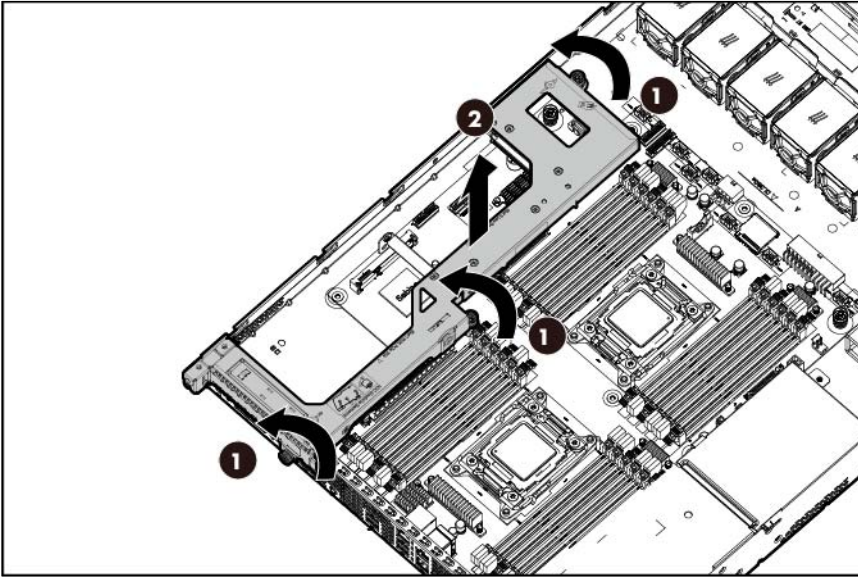

To replace the component, reverse the removal procedure.

Expansion boards

To remove the component:

1. If installed, remove the rack bezel ("[Rack bezel](#)" on page 28).
2. Power down the server (on page 26).
3. Remove all power:
 - a. Disconnect each power cord from the power source.
 - b. Disconnect each power cord from the server.
4. Extend the server from the rack (on page 26).
5. Remove the access panel ("[Access panel](#)" on page 28).
6. Remove the processor air baffle ("[Processor air baffle](#)" on page 41).
7. Remove the PCI riser cage ("[PCI riser cage](#)" on page 42).
8. Remove the expansion board:

- Half-length

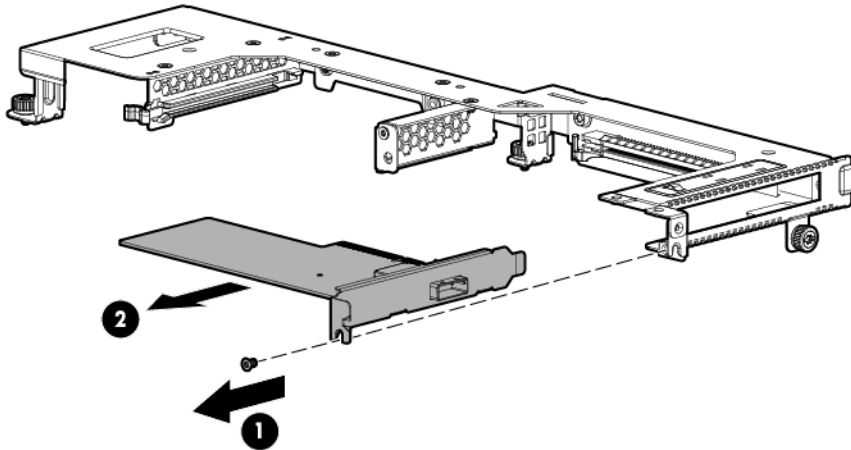

- Full-height, full-length

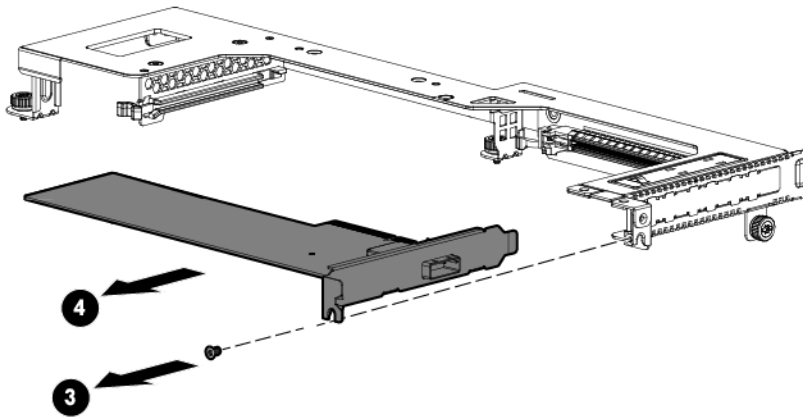

To replace the component, reverse the removal procedure.

FBWC capacitor pack



CAUTION: To prevent a server malfunction or damage to the equipment, do not add or remove the battery pack while an array capacity expansion, RAID level migration, or stripe size migration is in progress.

To remove the component:

1. If installed, remove the rack bezel ("[Rack bezel](#)" on page 28).
2. Power down the server (on page 26).
3. Remove all power:

- a. Disconnect each power cord from the power source.
 - b. Disconnect each power cord from the server.
4. Extend the server from the rack (on page 26).
5. Remove the access panel ("Access panel" on page 28).
6. Remove the processor air baffle ("Processor air baffle" on page 41).
7. Disconnect the cable from the cache module or PCIe controller.
8. Remove the FBWC capacitor pack.
 - o SFF configuration

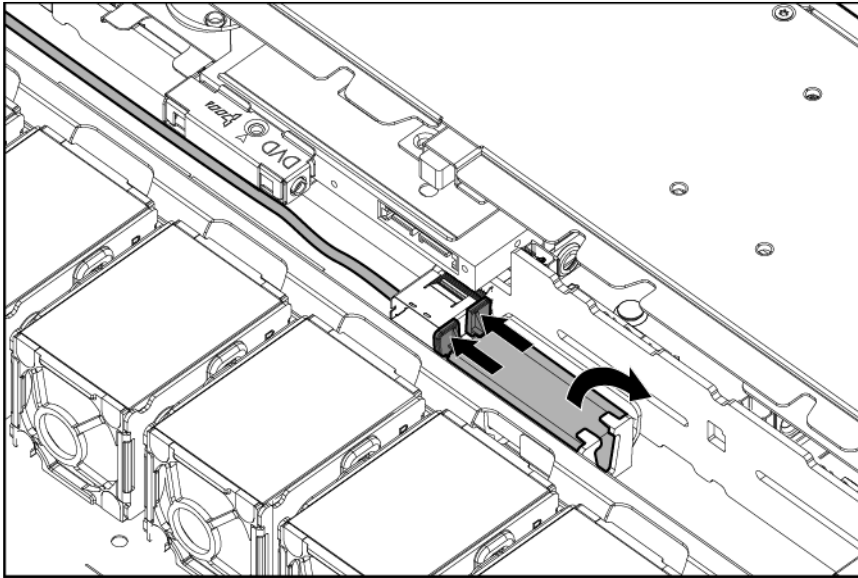

- o LFF configuration

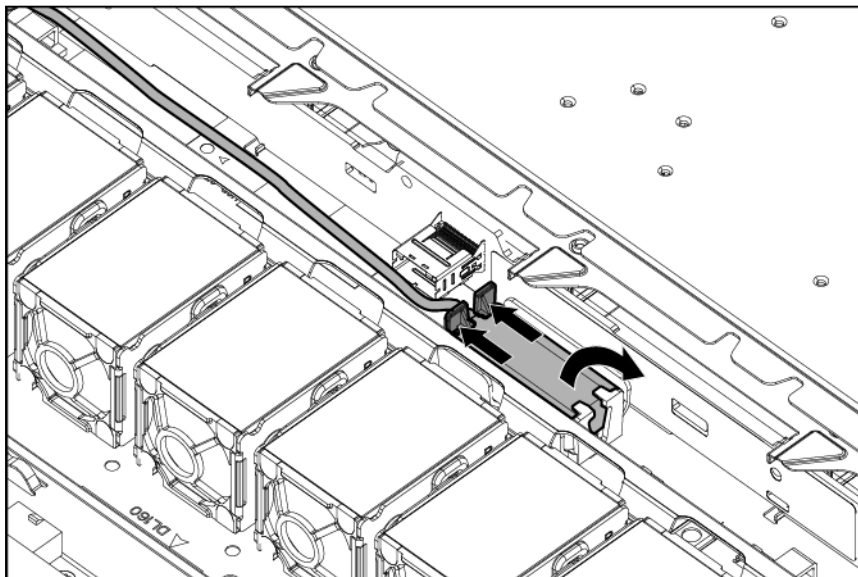

To replace the component, reverse the removal procedure.

DIMM blanks

To remove the component:

1. If installed, remove the rack bezel ("[Rack bezel](#)" on page 28).
2. Power down the server (on page 26).
3. Remove all power:
 - a. Disconnect each power cord from the power source.
 - b. Disconnect each power cord from the server.
4. Extend the server from the rack (on page 26).
5. Remove the access panel ("[Access panel](#)" on page 28).
6. Remove the processor air baffle ("[Processor air baffle](#)" on page 41).
7. Open the DIMM slot latches
8. Remove the DIMM blanks.

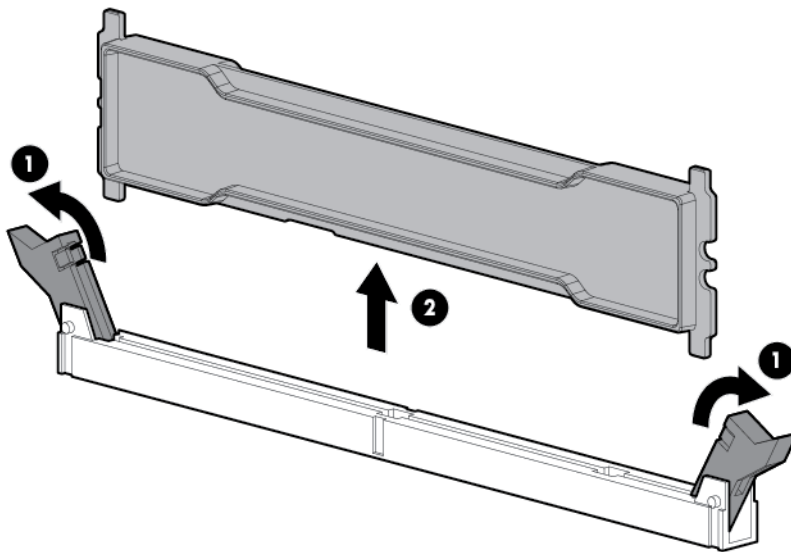

To replace the component, reverse the removal procedure.

DIMMs

To remove the component:

1. If installed, remove the rack bezel ("[Rack bezel](#)" on page 28).
2. Power down the server (on page 26).
3. Remove all power:
 - a. Disconnect each power cord from the power source.
 - b. Disconnect each power cord from the server.
4. Extend the server from the rack (on page 26).
5. Remove the access panel ("[Access panel](#)" on page 28).
6. Remove the processor air baffle ("[Processor air baffle](#)" on page 41).

7. Remove the DIMM.

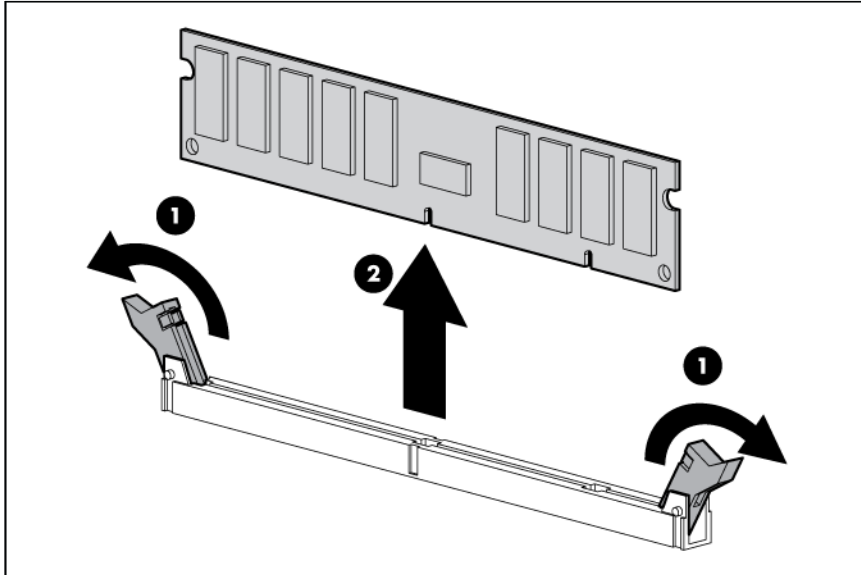

To replace the component, reverse the removal procedure.

Internal USB cable

To remove the component:

1. If installed, remove the rack bezel ("[Rack bezel](#)" on page [28](#)).
2. Power down the server (on page [26](#)).
3. Remove all power:
 - a. Disconnect each power cord from the power source.
 - b. Disconnect each power cord from the server.
4. Extend the server from the rack (on page [26](#)).
5. Remove the access panel ("[Access panel](#)" on page [28](#)).
6. Remove the processor air baffle ("[Processor air baffle](#)" on page [41](#)).
7. Do one of the following:

- Disconnect the USB cable from the system board, and then remove the internal USB connector from the LFF drive cage.

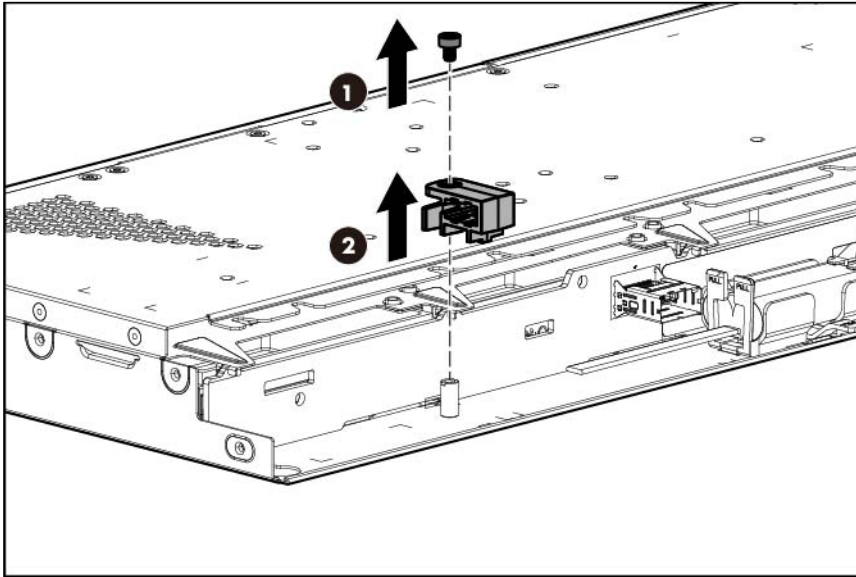

- Disconnect the USB cable from the system board, and then remove the internal USB connector from the SFF drive cage.

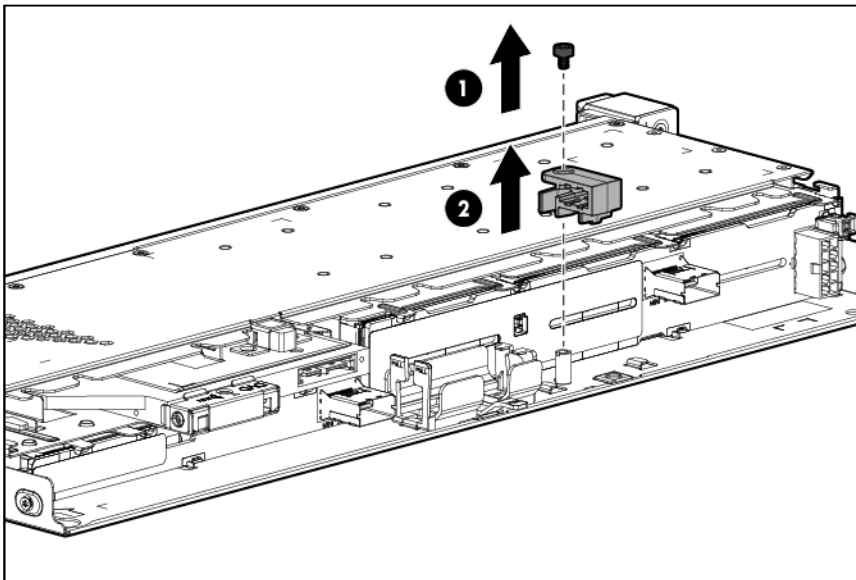

To replace the component, reverse the removal procedure.

Heatsink

1. To remove the component:
2. If installed, remove the rack bezel ("[Rack bezel](#)" on page [28](#)).
3. Power down the server (on page [26](#)).
4. Remove all power:
 - a. Disconnect each power cord from the power source.

- b. Disconnect each power cord from the server.
5. Extend the server from the rack (on page 26).
6. Remove the access panel ("[Access panel](#)" on page 28).
7. Remove the processor air baffle ("[Processor air baffle](#)" on page 41).
8. Remove the heatsink.

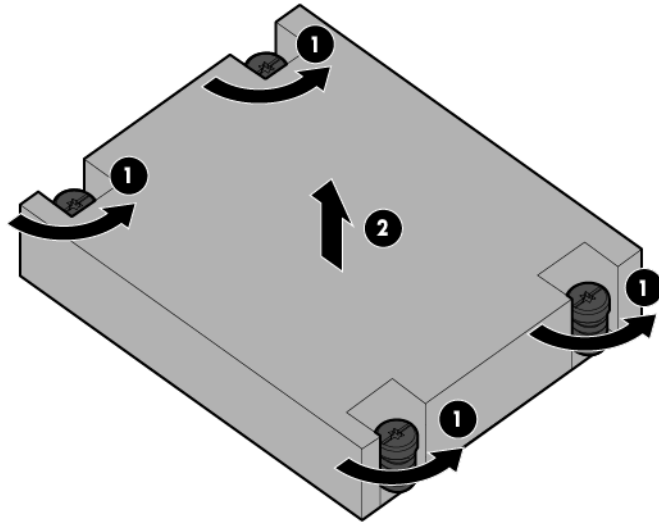

To replace the component:

1. Clean the old thermal grease from the top of the processor with the alcohol swab. Allow the alcohol to evaporate before continuing.
2. Remove the thermal interface protective cover from the heatsink.

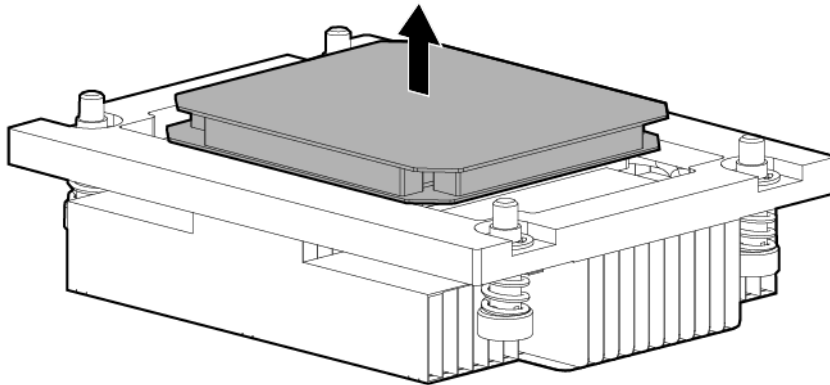



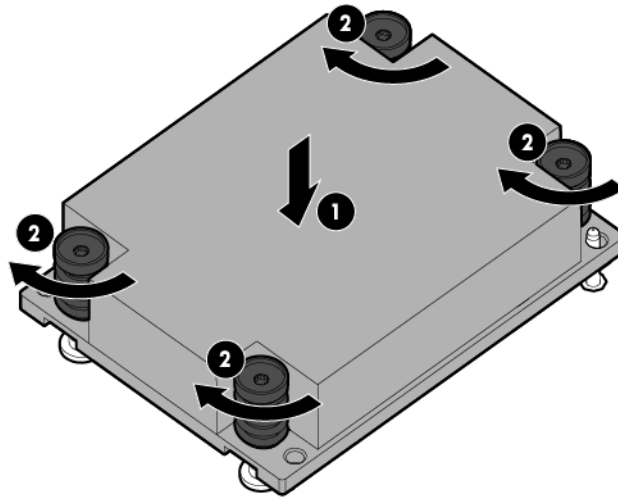



3. Install the heatsink.



4. Install the processor air baffle.
5. Install the access panel.
6. Slide the server into the rack.
7. Connect each power cord to the server.
8. Connect each power cord to the power source.
9. Power up the server.
10. If removed, install the rack bezel.

Processor

-
-  **WARNING:** To reduce the risk of personal injury from hot surfaces, allow the drives and the internal system components to cool before touching them.
-
-  **CAUTION:** To prevent possible server malfunction and damage to the equipment, multiprocessor configurations must contain processors with the same part number.
-
-  **CAUTION:** The heatsink thermal interface media is not reusable and must be replaced if the heatsink is removed from the processor after it has been installed.
-
-  **CAUTION:** To prevent possible server overheating, always populate processor socket 2 with a processor and a heatsink or a processor socket cover and a heatsink blank.
-
-  **CAUTION:** To avoid thermal shutdown, all fans must be installed in a dual processor configuration.
-
-  **IMPORTANT:** Processor socket 1 must be populated at all times or the server does not function.
-

To remove the processor:

1. If installed, remove the rack bezel ("[Rack bezel](#)" on page 28).
2. Power down the server (on page 26).
3. Remove all power:
 - a. Disconnect each power cord from the power source.
 - b. Disconnect each power cord from the server.
4. Extend the server from the rack (on page 26).
5. Remove the access panel ("[Access panel](#)" on page 28).
6. Remove the processor air baffle ("[Processor air baffle](#)" on page 41).
7. Remove the heatsink.

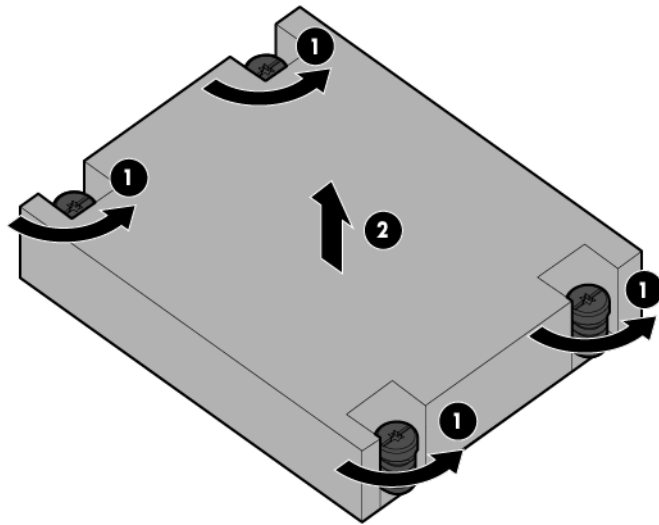

8. Open each of the processor locking levers in the order indicated, and then open the processor retaining bracket.

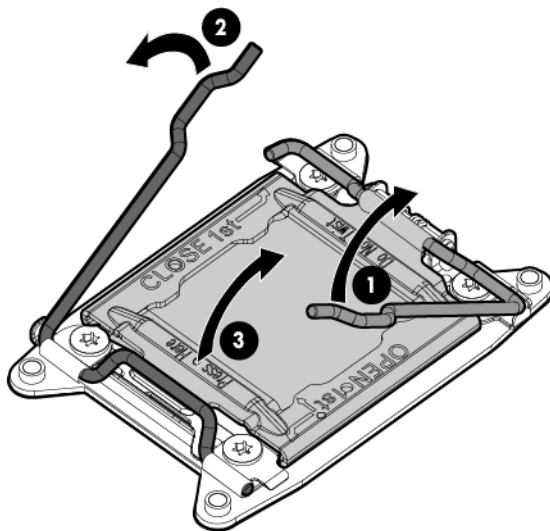

9. Remove the processor from the processor retaining bracket.

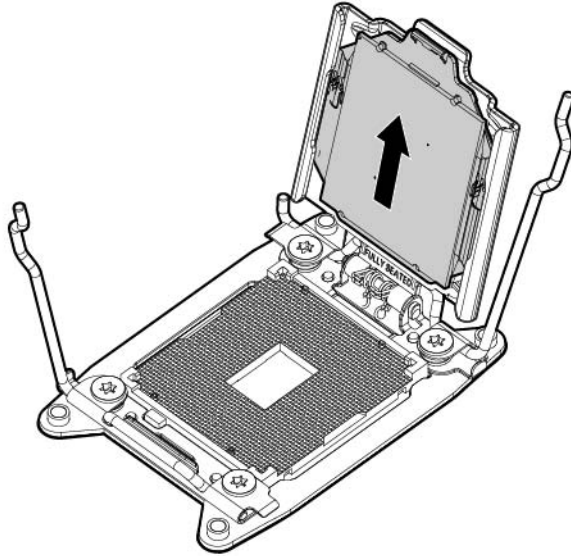

CAUTION: To avoid damage to the processor, do not touch the bottom of the processor, especially the contact area.

To replace the processor:

1. Install the processor. Verify that the processor is fully seated in the processor retaining bracket by visually inspecting the processor installation guides on either side of the processor. **THE PINS ON THE SYSTEM BOARD ARE VERY FRAGILE AND EASILY DAMAGED.**

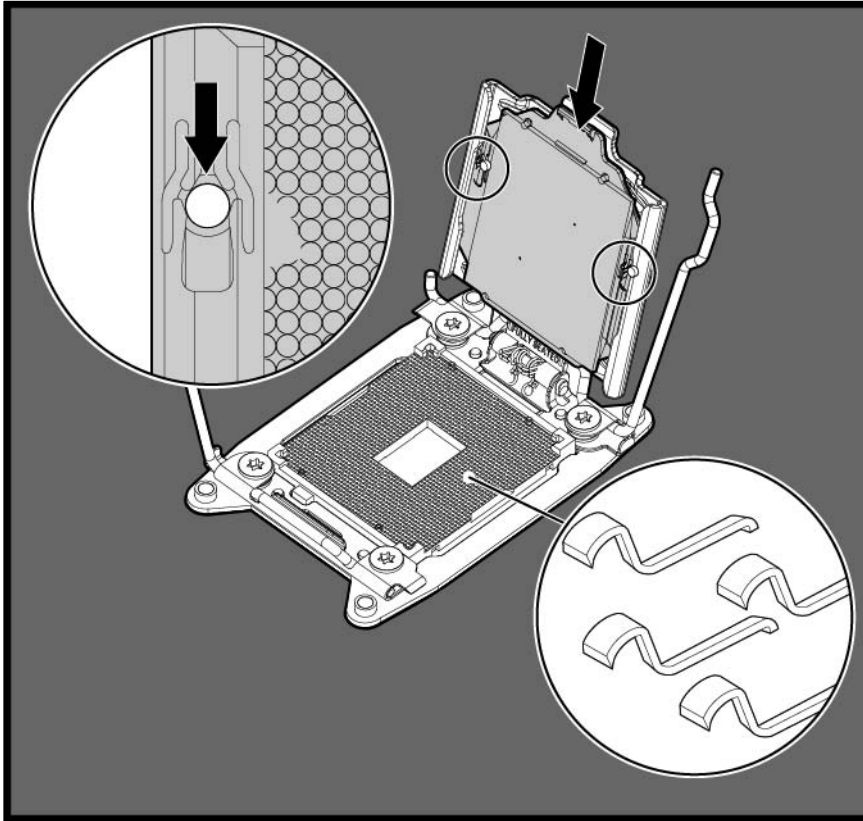

CAUTION: THE PINS ON THE SYSTEM BOARD ARE VERY FRAGILE AND EASILY DAMAGED. To avoid damage to the system board, do not touch the processor or the processor socket contacts.

2. Close the processor retaining bracket. When the processor is installed properly inside the processor retaining bracket, the processor retaining bracket clears the flange on the front of the socket.

CAUTION: Do not press down on the processor. Pressing down on the processor may cause damage to the processor socket and the system board. Press only in the area indicated on the processor retaining bracket.

3. Press and hold the processor retaining bracket in place, and then close each processor locking lever. Press only in the area indicated on the processor retaining bracket.

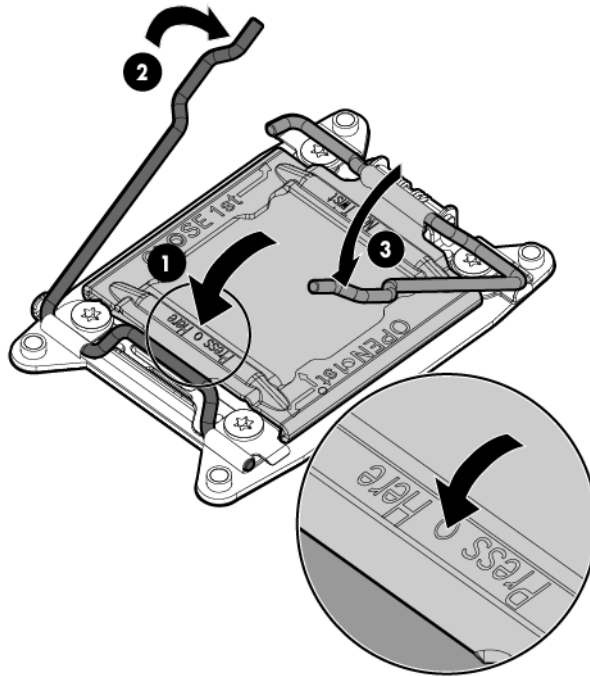

4. Clean the old thermal grease from the bottom of the heatsink with the alcohol swab. Allow the alcohol to evaporate before continuing.
5. Apply all the grease to the top of the processor in the following pattern to ensure even distribution.

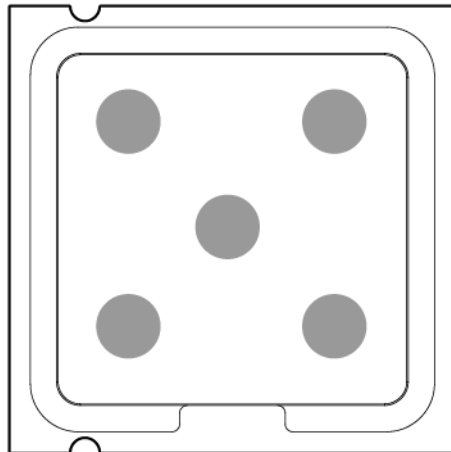

6. Install the heatsink.

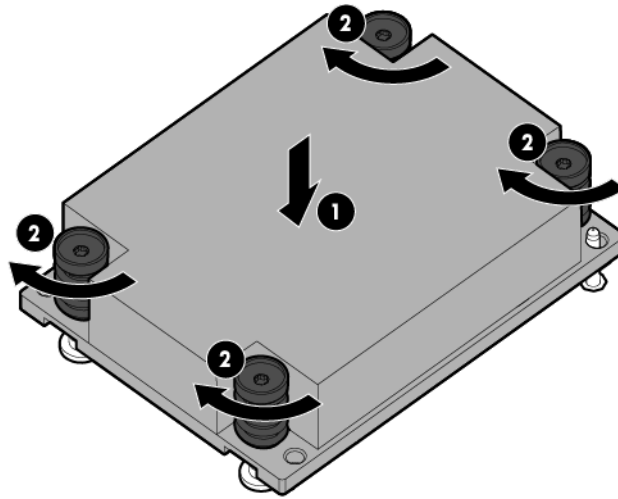

7. Install the processor air baffle.
8. Install the access panel.
9. Slide the server into the rack.
10. Connect each power cord to the server.
11. Connect each power cord to the power source.
12. Power up the server.
13. If removed, install the rack bezel.

System board

To remove the component:



IMPORTANT: Be sure you are using the correct spare part. The HP ProLiant DL160 Gen8 Server ships with one of two different system boards that each use specific processors and heatsinks. To identify the proper system board spare part number, see the white label on the system board that shipped with the server.

1. If installed, remove the rack bezel ("[Rack bezel](#)" on page 28).
2. Power down the server (on page 26).
3. Remove all power:
 - a. Disconnect each power cord from the power source.
 - b. Disconnect each power cord from the server.
4. Remove the server from the rack (on page 27).
5. Remove the access panel ("[Access panel](#)" on page 28).
6. Remove the processor air baffle ("[Processor air baffle](#)" on page 41).
7. Remove all power supplies ("[Power supply module](#)" on page 29).
8. If installed, remove the FBWC capacitor pack ("[FBWC capacitor pack](#)" on page 44).

CAUTION: To prevent damage to the server or expansion boards, power down the server and remove all AC power cords before removing or installing the PCI riser cage.

9. Remove the PCI riser cage ("PCI riser cage" on page 42).
10. Disconnect all fan cables from the system board, then remove all fans.
11. Disconnect all cables connected to the system board ("System board components" on page 76). For more information, see "Cabling (on page 64)."
12. Remove the FlexibleLOM ("FlexibleLOM option" on page 37).
13. Remove all DIMMs ("DIMMs" on page 46).
14. Remove the heatsink.

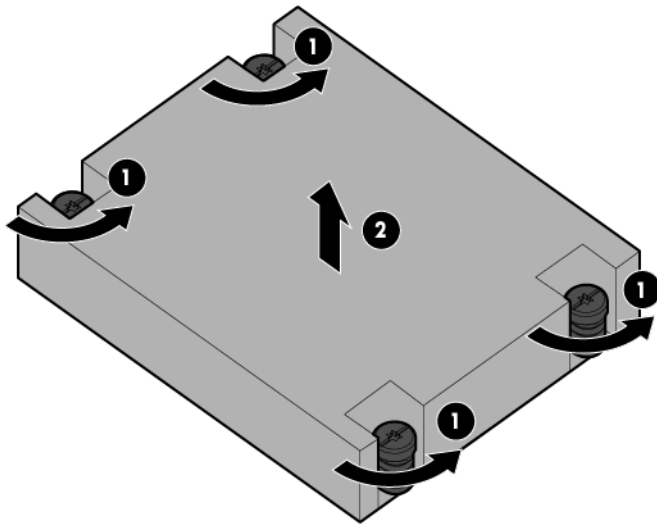

15. Open each of the processor locking levers in the order indicated, and then open the processor retaining bracket.

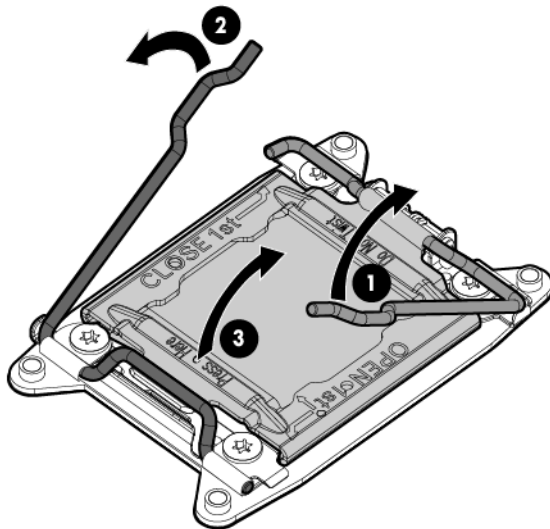

16. Remove the processor from the processor retaining bracket.

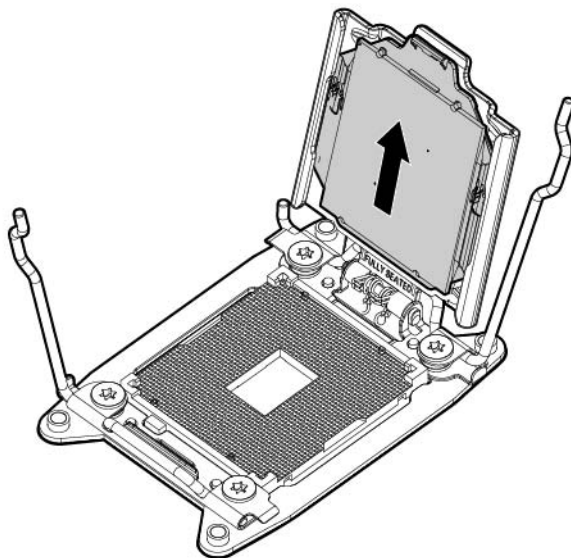

CAUTION: To avoid damage to the processor, do not touch the bottom of the processor, especially the contact area.

17. Loosen the two thumbscrews, and then remove the failed system board.

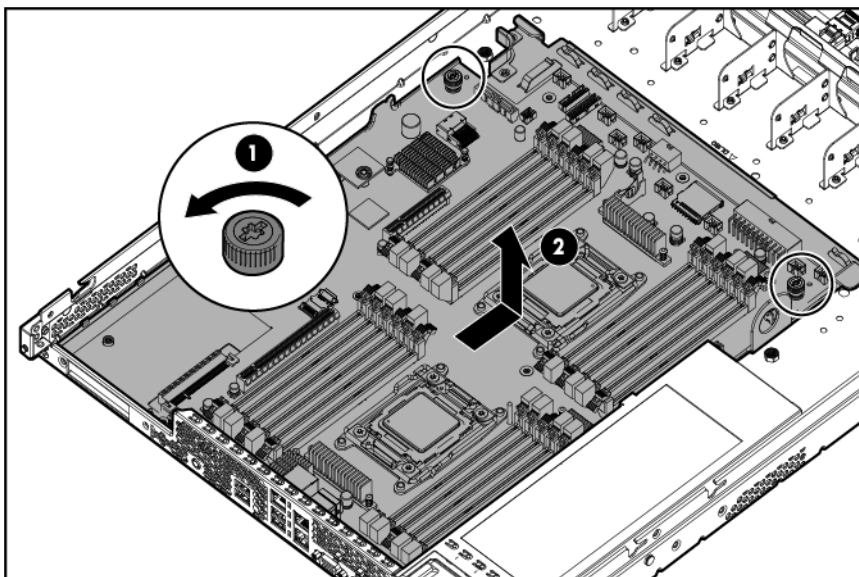

To replace the system board:

1. Align the system board on the tray, and then tighten the thumbscrews.

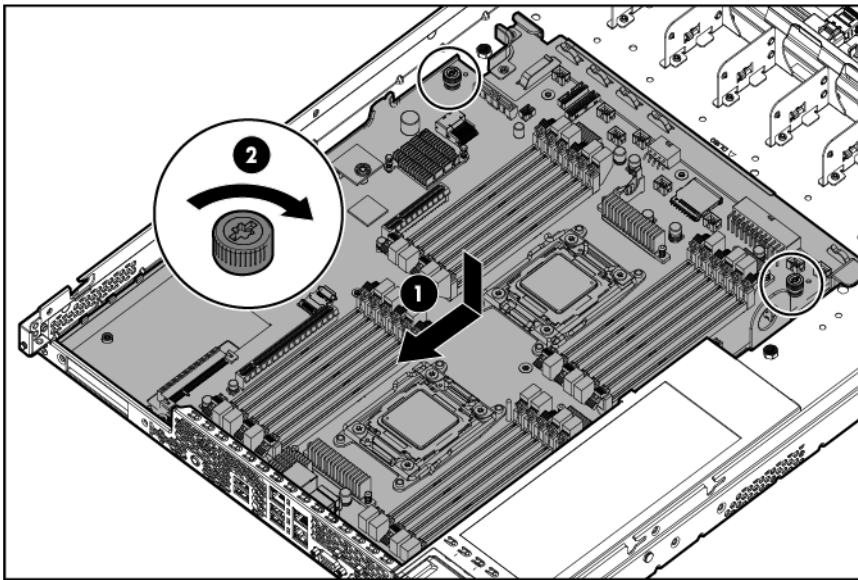

2. Open each of the processor locking levers in the order indicated, and then open the processor retaining bracket.

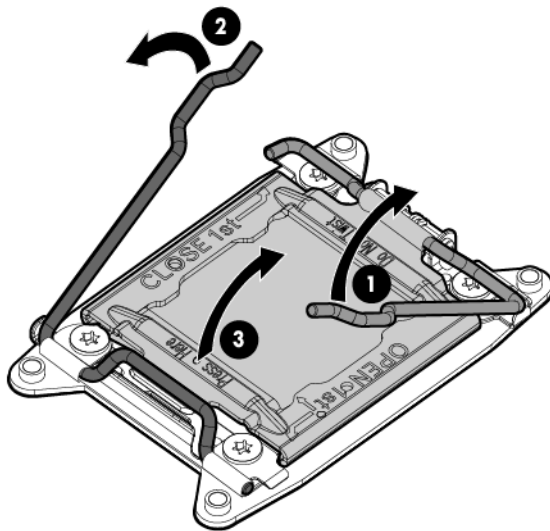

3. Remove the clear processor socket cover. Retain the processor socket cover for future use.

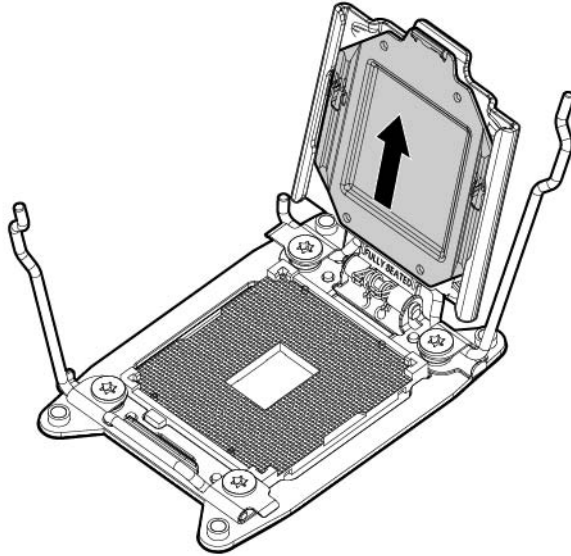

4. Install the processor. Verify that the processor is fully seated in the processor retaining bracket by visually inspecting the processor installation guides on either side of the processor. **THE PINS ON THE SYSTEM BOARD ARE VERY FRAGILE AND EASILY DAMAGED.**

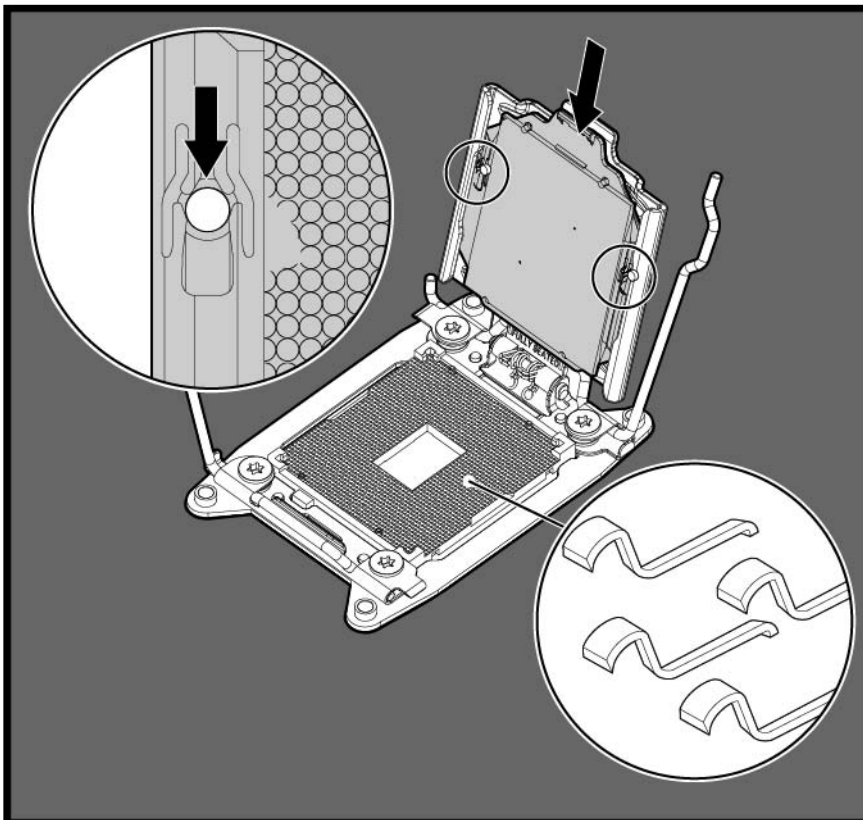

CAUTION: THE PINS ON THE SYSTEM BOARD ARE VERY FRAGILE AND EASILY DAMAGED. To avoid damage to the system board, do not touch the processor or the processor socket contacts.

5. Close the processor retaining bracket. When the processor is installed properly inside the processor retaining bracket, the processor retaining bracket clears the flange on the front of the socket.



CAUTION: Do not press down on the processor. Pressing down on the processor may cause damage to the processor socket and the system board. Press only in the area indicated on the processor retaining bracket.

6. Press and hold the processor retaining bracket in place, and then close each processor locking lever. Press only in the area indicated on the processor retaining bracket.

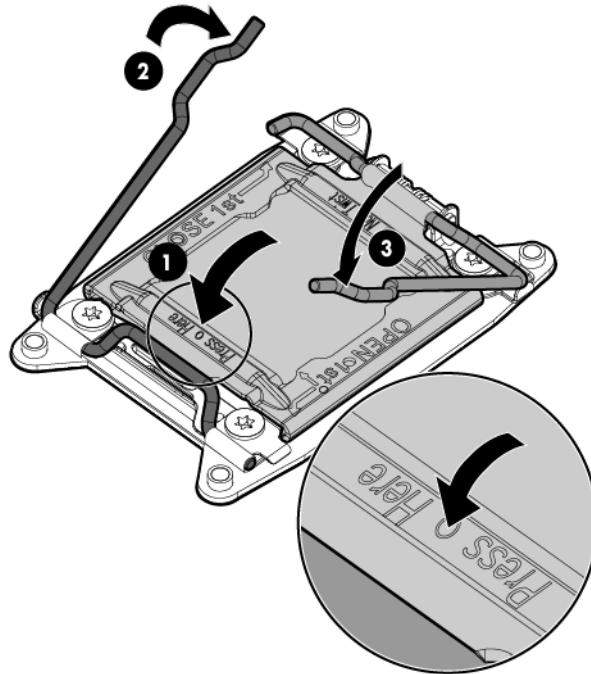

7. Install the processor socket cover onto the processor socket of the failed system board.
8. Clean the old thermal grease from the bottom of the heatsink and the top of the processor with the alcohol swab. Allow the alcohol to evaporate before continuing.
9. Apply all the grease to the top of the processor in the following pattern to ensure even distribution.

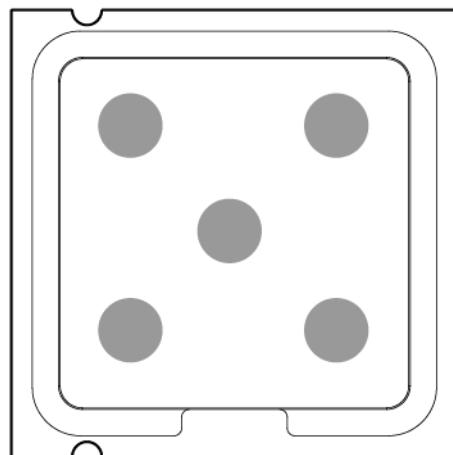

10. Install the heatsink.

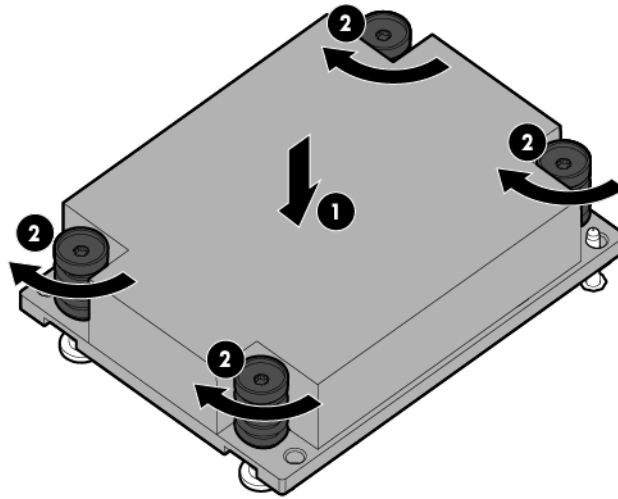

11. Install all components removed from the failed system board.



IMPORTANT: Install all components with the same configuration that was used on the failed system board.

12. Connect each power cord to the server.
13. Connect each power cord to the power source.
14. Power up the server.
15. If removed, install the rack bezel.

After you replace the system board, you must re-enter the server serial number and the product ID.

1. During the server startup sequence, press the **F9** key to access RBSU.
2. Select the **Advanced Options** menu.
3. Select **Service Options**.
4. Select **Serial Number**. The following warnings appear:
WARNING! WARNING! WARNING! The serial number is loaded into the system during the manufacturing process and should NOT be modified. This option should only be used by qualified service personnel. This value should always match the serial number sticker located on the chassis.
Warning: The serial number should ONLY be modified by qualified personnel. This value should always match the serial number located on the chassis.
5. Press the **Enter** key to clear the warning.
6. Enter the serial number and press the **Enter** key.
7. Select **Product ID**. The following warning appears:
Warning: The Product ID should ONLY be modified by qualified personnel. This value should always match the Product ID on the chassis.
8. Enter the product ID and press the **Enter** key.
9. Press the **Esc** key to close the menu.
10. Press the **Esc** key to exit RBSU.
11. Press the **F10** key to confirm exiting RBSU. The server automatically reboots.

System battery

If the server no longer automatically displays the correct date and time, you may need to replace the battery that provides power to the real-time clock. Under normal use, battery life is 5 to 10 years.



WARNING: The computer contains an internal lithium manganese dioxide, a vanadium pentoxide, or an alkaline battery pack. A risk of fire and burns exists if the battery pack is not properly handled. To reduce the risk of personal injury:

- Do not attempt to recharge the battery.
- Do not expose the battery to temperatures higher than 60°C (140°F).
- Do not disassemble, crush, puncture, short external contacts, or dispose of in fire or water.
- Replace only with the spare designated for this product.

To remove the component:

1. If installed, remove the rack bezel ("[Rack bezel](#)" on page 28).
2. Power down the server (on page 26).
3. Remove all power:
 - a. Disconnect each power cord from the power source.
 - b. Disconnect each power cord from the server.
4. Extend the server from the rack (on page 26).
5. Remove the access panel ("[Access panel](#)" on page 28).
6. Remove the processor air baffle ("[Processor air baffle](#)" on page 41).
7. Locate the battery on the system board ("[System board components](#)" on page 76).
8. Remove the battery.

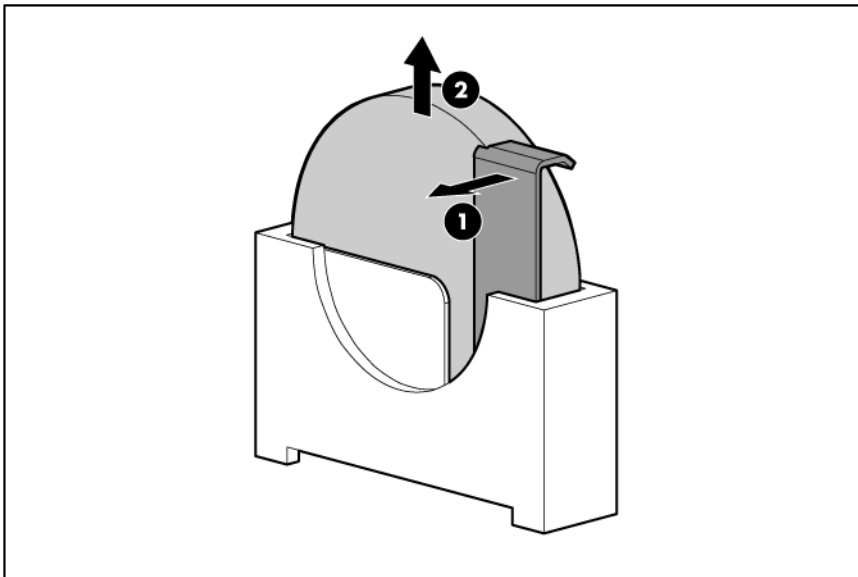

IMPORTANT: Replacing the system board battery resets the system ROM to its default configuration. After replacing the battery, reconfigure the system through RBSU.

To replace the component, reverse the removal procedure.

For more information about battery replacement or proper disposal, contact an authorized reseller or an authorized service provider.

HP Trusted Platform Module

The TPM is not a customer-removable part.



CAUTION: Any attempt to remove an installed TPM from the system board breaks or disfigures the TPM security rivet. Upon locating a broken or disfigured rivet on an installed TPM, administrators should consider the system compromised and take appropriate measures to ensure the integrity of the system data.

If you suspect a TPM board failure, leave the TPM installed and remove the system board. Contact an HP authorized service provider for a replacement system board and TPM board.

Cabling

Cabling overview

This section provides guidelines that help you make informed decisions about cabling the server and hardware options to optimize performance.

For information on cabling peripheral components, refer to the white paper on high-density deployment at the HP website (<http://www.hp.com/products/servers/platforms>).

CAUTION: When routing cables, always be sure that the cables are not in a position where they can be pinched or crimped.

Data cabling

P420 Smart Array Controller cabling

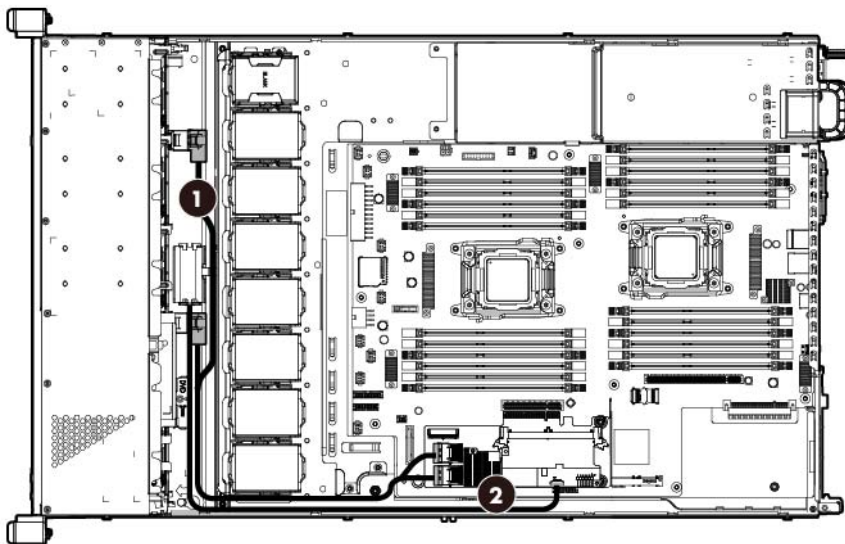

Cable number	Description
1	SAS cable
2	FBWC capacitor pack cable

SATA cabling

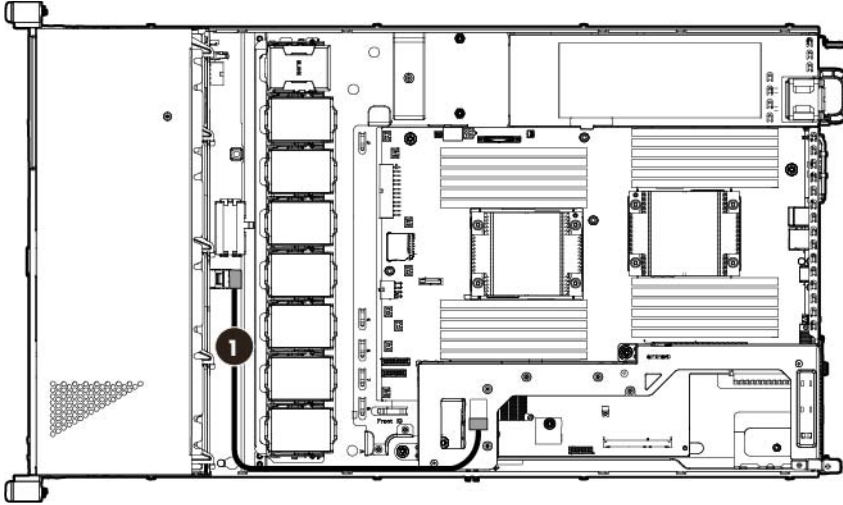

Cable number	Description
1	SATA Cable

Power cabling

Server power cabling

Basic configuration

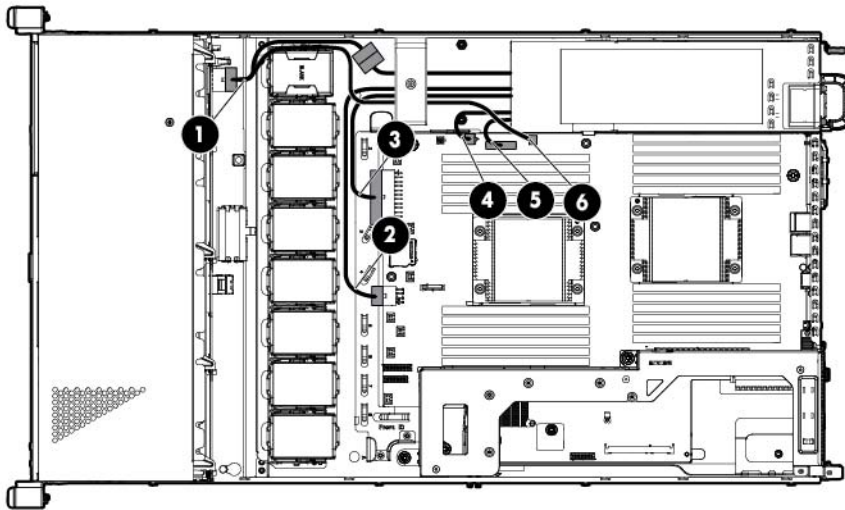

Cable number	Description
1	Drive backplane cable
2	2x4 Power supply cable
3	2x12 Power supply cable
4	2x2 Power supply cable
5	RPS control cable

Cable number	Description
6	Discovery service cable

Maximum configuration

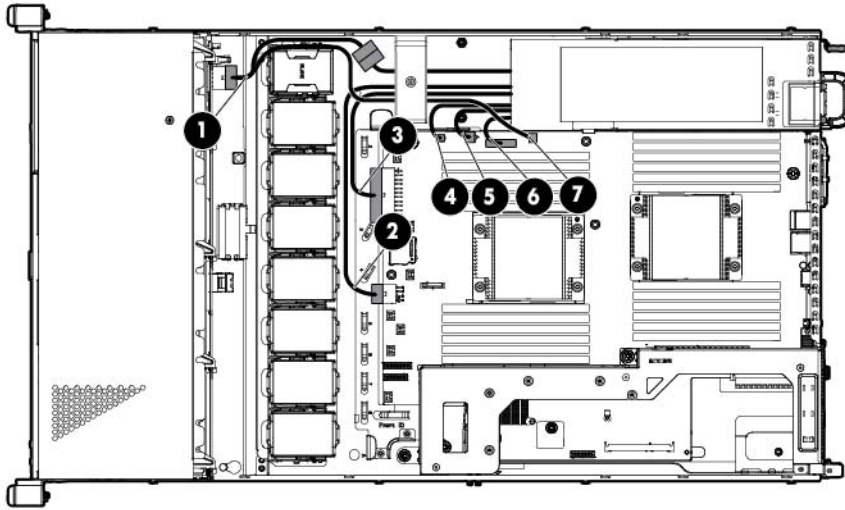

Cable number	Description
1	Drive backplane cable
2	2x4 Power supply cable
3	2x12 Power supply cable
4	FlexibleLOM standby power cable
5	2x2 Power supply cable
6	RPS control cable
7	Discovery service cable

FBWC capacitor pack cabling

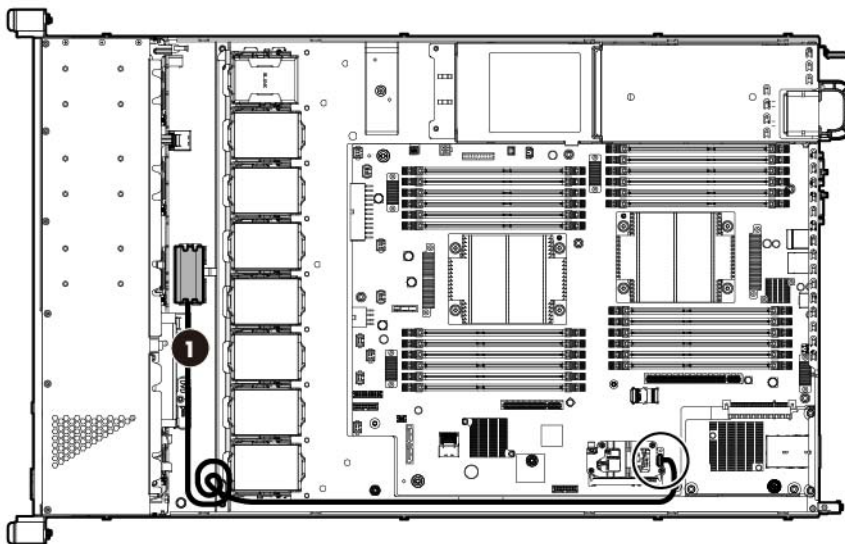

Cable number	Description
1	FBWC capacitor pack cable

Front panel cabling

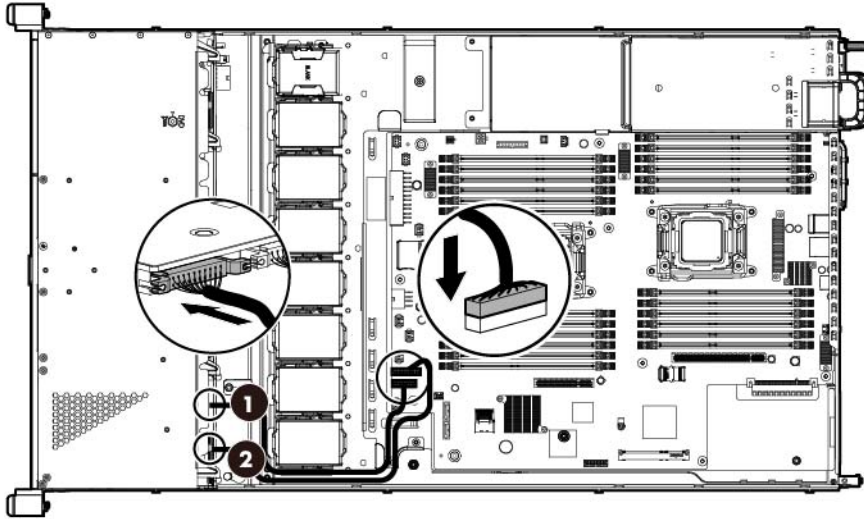

Cable number	Description
1	2x10 Front panel IO cables
2	2x12 Front panel IO cables

Internal USB cabling

SFF configuration

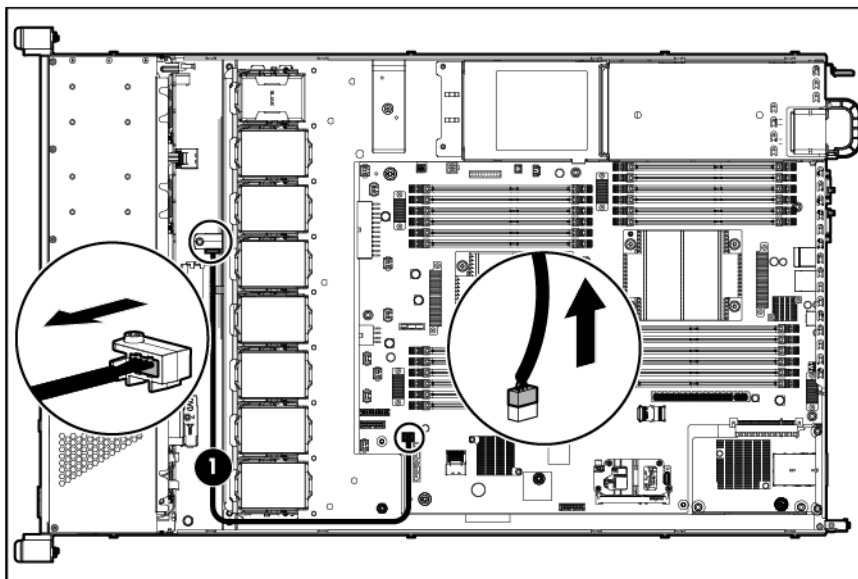

Cable number	Description
1	Internal USB cable

LFF configuration

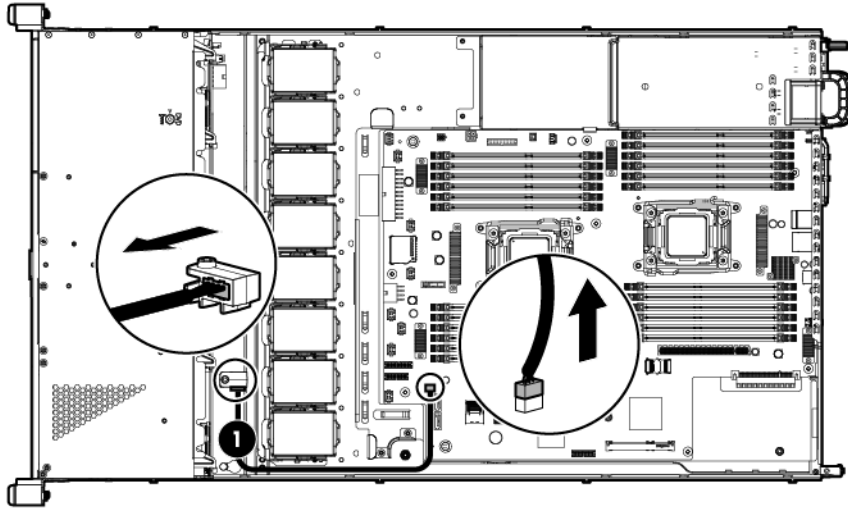

Cable number	Description
1	Internal USB cable

Diagnostic tools

Troubleshooting resources

The *HP ProLiant Servers Troubleshooting Guide* provides procedures for resolving common problems and comprehensive courses of action for fault isolation and identification, error message interpretation, issue resolution, and software maintenance on ProLiant servers and server blades. This guide includes problem-specific flowcharts to help you navigate complex troubleshooting processes. To view the guide, select a language:

- English (http://www.hp.com/support/ProLiant_TSG_en)
- French (http://www.hp.com/support/ProLiant_TSG_fr)
- Italian (http://www.hp.com/support/ProLiant_TSG_it)
- Spanish (http://www.hp.com/support/ProLiant_TSG_sp)
- German (http://www.hp.com/support/ProLiant_TSG_gr)
- Dutch (http://www.hp.com/support/ProLiant_TSG_nl)
- Japanese (http://www.hp.com/support/ProLiant_TSG_jp)

HP ROM-Based Setup Utility

RBSU is a configuration utility embedded in ProLiant servers that performs a wide range of configuration activities that can include the following:

- Configuring system devices and installed options
- Enabling and disabling system features
- Displaying system information
- Selecting the primary boot controller
- Configuring memory options
- Language selection

For more information on RBSU, see the *HP ROM-Based Setup Utility User Guide* on the Documentation CD or the HP website (<http://www.hp.com/support/smartstart/documentation>).

HP Insight Diagnostics

HP Insight Diagnostics is a proactive server management tool, available in both offline and online versions, that provides diagnostics and troubleshooting capabilities to assist IT administrators who verify server installations, troubleshoot problems, and perform repair validation.

HP Insight Diagnostics Offline Edition performs various in-depth system and component testing while the OS is not running. To run this utility, launch the SmartStart CD.

HP Insight Diagnostics Online Edition is a web-based application that captures system configuration and other related data needed for effective server management. Available in Microsoft® Windows® and Linux versions, the utility helps to ensure proper system operation.

For more information or to download the utility, refer to the HP website (<http://www.hp.com/servers/diags>).

HP Insight Diagnostics survey functionality

HP Insight Diagnostics (on page 69) provides survey functionality that gathers critical hardware and software information on ProLiant servers.

This functionality supports operating systems that may not be supported by the server. For operating systems supported by the server, see the HP website (<http://www.hp.com/go/supportos>).

If a significant change occurs between data-gathering intervals, the survey function marks the previous information and overwrites the survey data files to reflect the latest changes in the configuration.

Survey functionality is installed with every SmartStart-assisted HP Insight Diagnostics installation, or it can be installed through the HP PSP.

NOTE: The current version of SmartStart provides the memory spare part numbers for the server. To download the latest version, see the HP website (<http://www.hp.com/support>).

Integrated Management Log

The IML records hundreds of events and stores them in an easy-to-view form. The IML timestamps each event with 1-minute granularity.

You can view recorded events in the IML in several ways, including the following:

- From within HP SIM
- From within Survey Utility
- From within operating system-specific IML viewers
 - For NetWare: IML Viewer (does not apply to HP ProLiant DL980 Servers)
 - For Windows®: IML Viewer
 - For Linux: IML Viewer Application
- From within the iLO 3 user interface
- From within HP Insight Diagnostics (on page 69)

For more information, see the Management CD or DVD in the HP Insight Foundation suite for ProLiant.

Automatic Server Recovery

ASR is a feature that causes the system to restart when a catastrophic operating system error occurs, such as a blue screen, ABEND (does not apply to HP ProLiant DL980 Servers), or panic. A system fail-safe timer, the ASR timer, starts when the System Management driver, also known as the Health Driver, is loaded. When the operating system is functioning properly, the system periodically resets the timer. However, when the operating system fails, the timer expires and restarts the server.

ASR increases server availability by restarting the server within a specified time after a system hang. At the same time, the HP SIM console notifies you by sending a message to a designated pager number that ASR has restarted the system. You can disable ASR from the System Management Homepage or through RBSU.

HP Insight Remote Support software

HP strongly recommends that you install HP Insight Remote Support software to complete the installation or upgrade of your product and to enable enhanced delivery of your HP Warranty, HP Care Pack Service, or HP contractual support agreement. HP Insight Remote Support supplements your monitoring 24 x 7 to ensure maximum system availability by providing intelligent event diagnosis, and automatic, secure submission of hardware event notifications to HP, which will initiate a fast and accurate resolution, based on your product's service level. Notifications may be sent to your authorized HP Channel Partner for on-site service, if configured and available in your country. The software is available in two variants:

- **HP Insight Remote Support Standard:** This software supports server and storage devices and is optimized for environments with 1–50 servers. Ideal for customers who can benefit from proactive notification but do not need proactive service delivery and integration with a management platform.
- **HP Insight Remote Support Advanced:** This software provides comprehensive remote monitoring and proactive service support for nearly all HP servers, storage, network, and SAN environments, plus selected non-HP servers that have a support obligation with HP. It is integrated with HP Systems Insight Manager. A dedicated server is recommended to host both HP Systems Insight Manager and HP Insight Remote Support Advanced.

Details for both versions are available on the HP website (<http://www.hp.com/go/insightremotesupport>).

To download the software, go to Software Depot (<http://www.software.hp.com>).

Select **Insight Remote Support** from the menu on the right.

Troubleshooting

Troubleshooting resources

The *HP ProLiant Gen8 Troubleshooting Guide, Volume I: Troubleshooting* provides procedures for resolving common problems and comprehensive courses of action for fault isolation and identification, issue resolution, and software maintenance on ProLiant servers and server blades. To view the guide, select a language:

- English (http://www.hp.com/support/ProLiant_TSG_v1_en)
- French (http://www.hp.com/support/ProLiant_TSG_v1_fr)
- Spanish (http://www.hp.com/support/ProLiant_TSG_v1_sp)
- German (http://www.hp.com/support/ProLiant_TSG_v1_gr)
- Japanese (http://www.hp.com/support/ProLiant_TSG_v1_jp)
- Simplified Chinese (http://www.hp.com/support/ProLiant_TSG_v1_sc)

The *HP ProLiant Gen8 Troubleshooting Guide, Volume II: Error Messages* provides a list of error messages and information to assist with interpreting and resolving error messages on ProLiant servers and server blades. To view the guide, select a language:

- English (http://www.hp.com/support/ProLiant_EMG_v1_en)
- French (http://www.hp.com/support/ProLiant_EMG_v1_fr)
- Spanish (http://www.hp.com/support/ProLiant_EMG_v1_sp)
- German (http://www.hp.com/support/ProLiant_EMG_v1_gr)
- Japanese (http://www.hp.com/support/ProLiant_EMG_v1_jp)
- Simplified Chinese (http://www.hp.com/support/ProLiant_EMG_v1_sc)

Component identification

Front panel components

- SFF

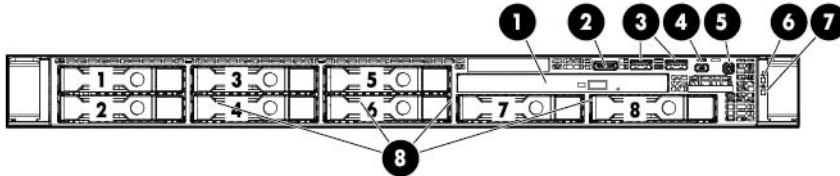

Item	Description
1	Optical drive
2	Front video connector (Front video port adapter required)
3	USB connectors (2)
4	UID LED button
5	Power on/Standby button and system power LED
6	Health LED
7	NIC status LED
8	SAS/SATA drives (8)

- LFF

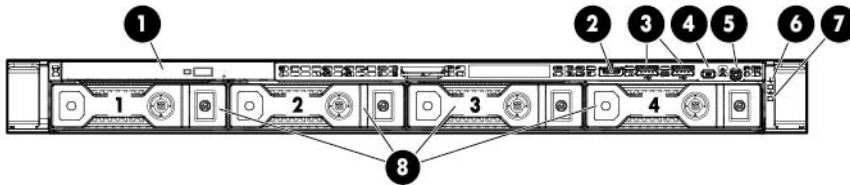

Item	Description
1	Optical drives
2	Front video connector (Front video port adapter required)
3	USB connectors (2)
4	UID LED button
5	Power on/Standby button and system power LED
6	Health LED
7	NIC status LED
8	SAS/SATA drives (4)

Front panel LEDs and buttons

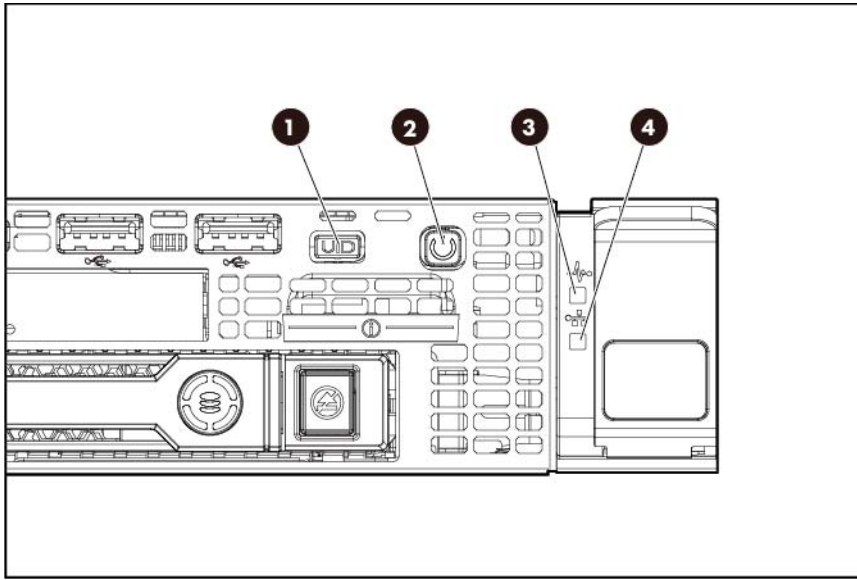

Item	Description	Status
1	UID LED/button	Blue = Identification is activated. Flashing blue = System is being managed remotely. Off = Identification is deactivated.
2	Power On/Standby button	Green = System is on. Flashing green = Waiting for power Amber = System is in standby, but power is still applied. Off = Power cord is not attached, power supply failure has occurred, no power supplies are installed, facility power is not available, or the power button cable is disconnected.
3	Health LED	Green = System health is normal. Flashing amber = System health is degraded. Flashing red = System health is critical. To identify the component in a critical state, check iLO/BIOS logs. Fast flashing red = Power fault (check system and devices)
4	NIC status LED	Green = Network link Flashing green = Network link and activity Off = No link to network

Rear panel components

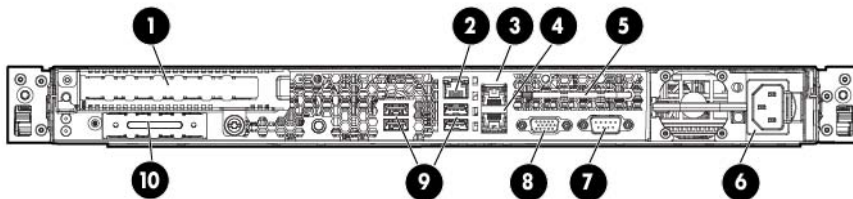

	Description
1	Slot 1 PCIe3 x16 (8, 4, 2, 1)
2	iLO connector
3	NIC connector 2
4	NIC connector 1
5	Torx tool
6	Power supply
7	Serial connector
8	Video connector
9	USB connectors (4)
10	FlexibleLOM slot

Rear panel LEDs and buttons

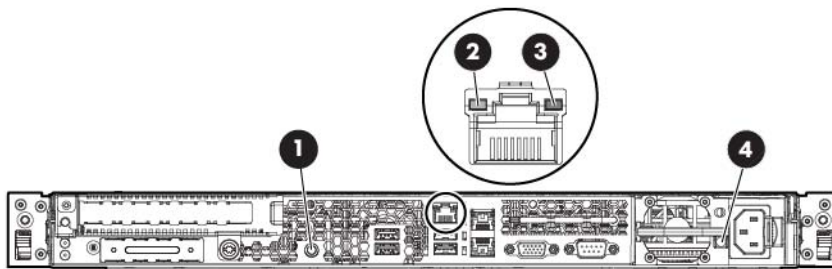

Item	Description	Status
1	iLO 3 NIC activity LED	Green = Activity exists Flashing green = Activity exists Off = No activity exists
2	iLO 3 NIC link LED	Green = Link exists Off = No link exists
3	UID button/LED	Blue = Identification is activated Flashing blue = System is being managed remotely Off = Identification is deactivated
4	Power supply LED	Green = Normal Off = One or more of the following conditions exists: <ul style="list-style-type: none"> • AC power unavailable • Power supply failed • Power supply in standby mode • Power supply exceeded current limit

System board components

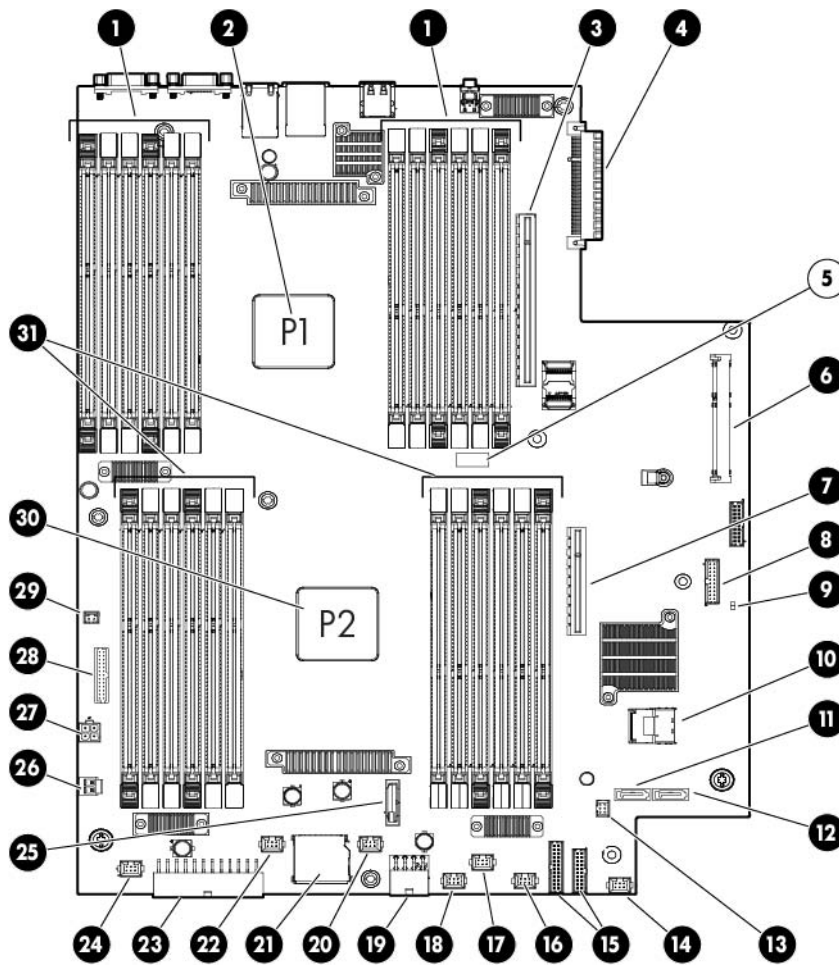

Item	Description
1	Processor 1 DIMM slots
2	Processor socket 1
3	PCI riser connector 1
4	FlexibleLOM connector
5	System maintenance switch
6	Cache module connector
7	PCI riser connector 2
8	TPM connector
9	NMI header
10	Mini-SAS connector
11	SATA connector 2
12	SATA connector 1
13	Internal USB connector
14	Fan connector 8
15	Front panel connectors
16	Fan connector 7
17	Fan connector 6

Item	Description
18	Fan connector 5
19	8-pin power connector
20	Fan connector 4
21	SD card slot
22	Fan connector 3
23	24-pin power connector
24	Fan connector 2
25	System battery
26	FlexibleLOM standby power connector
27	4-pin power connector
28	Redundant power supply connector
29	Discovery service connector
30	Processor socket 2
31	Processor 2 DIMM slots

DIMM slots

DIMM slots are numbered sequentially (1 through 12) for each processor. The supported AMP modes use the letter assignments for population guidelines.

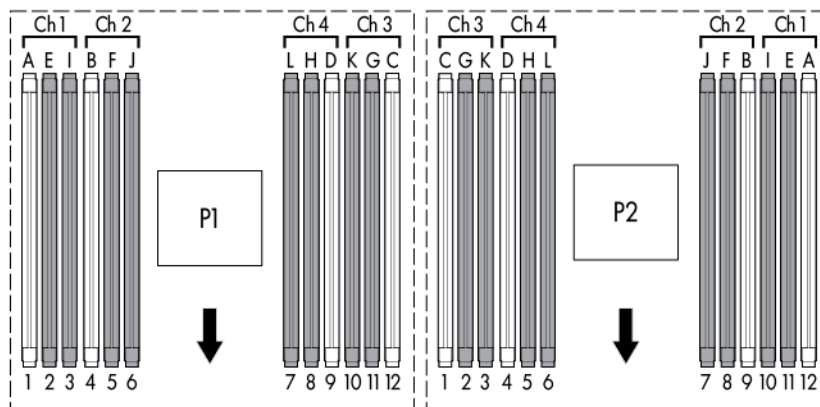

NOTE: For proper orientation, the arrows indicate the front of the server.

System maintenance switch

Position	Default	Function
S1	Off	Off = The iLO 3 security is enabled On = The iLO 3 security is disabled

Position	Default	Function
S2	Off	Off = System configuration can be changed On = System configuration is locked
S3	Off	Reserved
S4	Off	Reserved
S5	Off	Off = Power-on password is enabled On = Power-on password is disabled
S6	Off	Off = No function On = Reset configuration
S7	—	Reserved
S8	—	Reserved
S9	—	Reserved
S10	—	Reserved
S11	—	Reserved
S12	—	Reserved

When the system maintenance switch position 6 is set to the On position, the system is prepared to erase all system configuration settings from both CMOS and NVRAM.

△ CAUTION: Clearing CMOS and/or NVRAM deletes configuration information. Be sure to properly configure the server or data loss could occur.

NMI jumper

The NMI jumper allows administrators to perform a memory dump before performing a hard reset. Crash dump analysis is an essential part of eliminating reliability problems, such as hangs or crashes in OSs, device drivers, and applications. Many crashes can freeze a system, requiring you to do a hard reset. Resetting the system erases any information that would support root cause analysis.

Systems running Microsoft® Windows® experience a blue-screen trap when the OS crashes. When this happens, Microsoft® recommends that system administrators perform an NMI event by temporarily shorting the NMI header with a jumper. The NMI event enables a hung system to become responsive again.

Device numbers

- LFF configuration

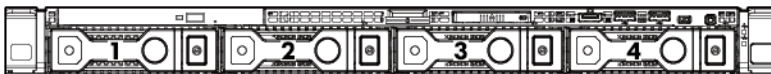

- SFF configuration



Drive LED definitions

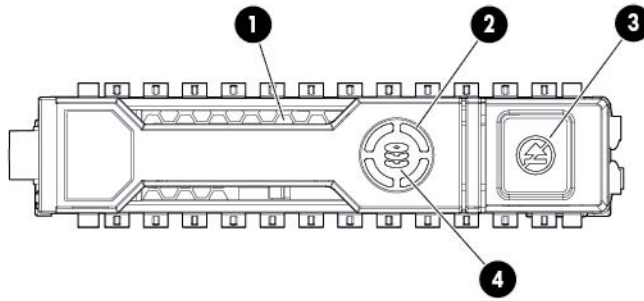

Item	LED	Status	Definition
1	Locate	Solid blue	The drive is being identified by a host application.
		Flashing blue	The drive carrier firmware is being updated or requires an update.
2	Activity ring	Rotating green	Drive activity
		Off	No drive activity
3	Do not remove	Solid white	Do not remove the drive. Removing the drive causes one or more of the logical drives to fail.
		Off	Removing the drive does not cause a logical drive to fail.
4	Drive status	Solid green	The drive is a member of one or more logical drives.
		Flashing green	The drive is rebuilding or performing a RAID migration, stripe size migration, capacity expansion, or logical drive extension, or is erasing.
		Flashing amber/green	The drive is a member of one or more logical drives and predicts the drive will fail.
		Flashing amber	The drive is not configured and predicts the drive will fail.
		Solid amber	The drive has failed.
		Off	The drive is not configured by a RAID controller.

Fan modules

- One-processor configuration

When only one processor is installed, for proper cooling, make sure the fan blanks are installed in fan positions 1, 2, and 5.

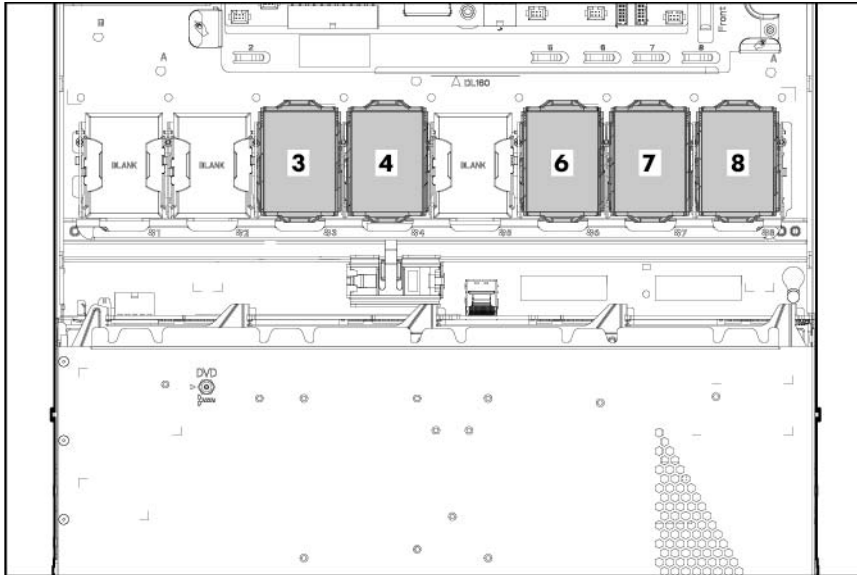

- Two-processor configuration

When processor 2 is installed, install fans in positions 2 and 5.

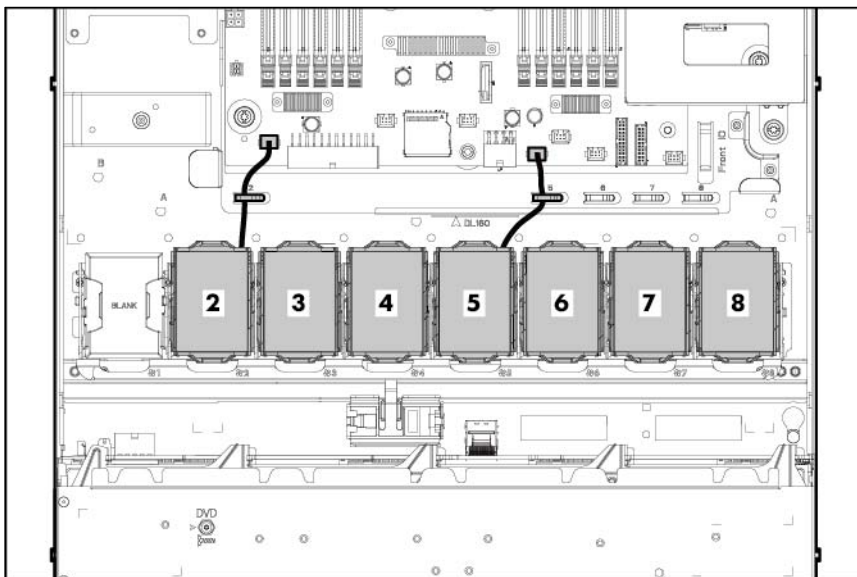

T-10/T-15 Torx screwdriver

The server ships with a T-10/T-15 Torx screwdriver. Use the screwdriver to loosen screws or thumbscrews, as needed, during procedures.

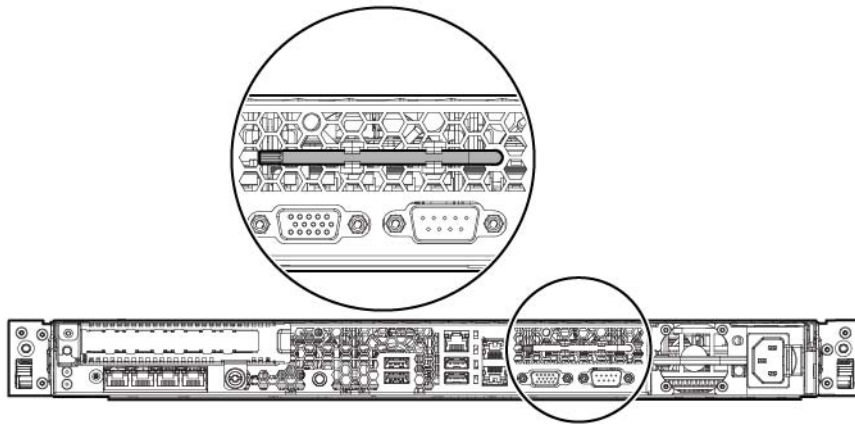

Specifications

Environmental specifications

Specification	Value
Temperature range*	
Operating	10°C to 35°C (50°F to 95°F)
Shipping	-40°C to 70°C (-40°F to 158°F)
Maximum wet bulb temperature	28°C (82.4°F)
Relative humidity (noncondensing)**	
Operating	10% to 90%
Non operating	5% to 95%

* All temperature ratings shown are for sea level. An altitude derating of 1°C per 300 m (1.8°F per 1,000 ft) to 3048 m (10,000 ft) is applicable. No direct sunlight allowed.

** Storage maximum humidity of 95% is based on a maximum temperature of 45°C (113°F). Altitude maximum for storage corresponds to a pressure minimum of 70 kPa.

Server specifications

Specification	Value
Height	4.32 cm (1.70 in)
Depth (chassis with SFF drive cage)	69.9 cm (27.5 in)
Depth (chassis with LFF drive cage)	75.0 cm (29.5 in)
Width	43.46 cm (17.11 in)
Weight (maximum SFF: two processors, one power supply, eight drives)	16.9 kg (37.25 lb)
Weight (maximum LFF: two processors, one power supply, four drives)	17.6 kg (38.80 lb)

Power supply specifications

Depending on installed options, the server is configured with one of the following power supplies:

- HP 460 W CS Power Supply (94%) specifications
- HP 500 W Multi-output Power Supply specifications

HP 460 W CS Power Supply (94%) specifications

Specification	Value
Input requirements	
Rated input voltage	100 to 240 VAC
Rated input frequency	50 Hz or 60 Hz
Rated input current	6 to 3 A
Rated input power	509 W at 115V AC input 495 W at 230V AC input
BTUs per hour	1764 at 100V AC 1736 at 115V AC 1694 at 200V AC 1687 at 230V AC
Power supply output	
Rated steady-state power	460 W at 100V to 120V AC input 460 W at 200V to 240V AC input
Maximum peak power	460 W at 100V to 120V AC input 460 W at 200V to 240V AC input

HP 500 W Multi-output Power Supply specifications

Specification	Value
Input requirements	
Rated input voltage	100 to 120 VAC, 200 to 240 VAC
Rated input frequency	47 HZ to 63 HZ
Rated input current	10 A to 5 A
Rated input power	556 W at 115V AC input 542 W at 230V AC input
BTUs per hour	1917 at 100 V AC 1898 at 115 V AC 1856 at 200 V AC 1850 at 230 V AC
Power supply output	
Rated steady-state power	500 W at 100V to 120V AC input 500 W at 200V to 240V AC input
Maximum peak power	500 W at 100V to 120V AC input 500 W at 200V to 240V AC input



CAUTION: This equipment is designed to permit the connection of the earthed conductor of the DC supply circuit to the earthing conductor at the equipment. See installation instructions.

-
- △ **CAUTION:** If the DC connection exists between the earthed conductor of the DC supply circuit and the earthing conductor at the server equipment, the following conditions must be met:
- This equipment must be connected directly to the DC supply system earthing electrode conductor or to a bonding jumper from an earthing terminal bar or bus to which the DC supply system earthing electrode conductor is connected.
 - This equipment should be located in the same immediate area (such as adjacent cabinets) as any other equipment that has a connection between the earthed conductor of the same DC supply circuit and the earthing conductor, and also the point of earthing of the DC system. The DC system should be earthed elsewhere.
 - The DC supply source is to be located within the same premises as the equipment.
 - Switching or disconnecting devices should not be in the earthed circuit conductor between the DC source and the point of connection of the earthing electrode conductor.
-
- △ **CAUTION:** To reduce the risk of electric shock or energy hazards:
- This equipment must be installed by trained service personnel, as defined by the NEC and IEC 60950-1, Second Edition, the standard for Safety of Information Technology Equipment.
 - Connect the equipment to a reliably grounded safety extra low voltage (SELV) source. An SELV source is a secondary circuit that is designed so normal and single fault conditions do not cause the voltages to exceed a safe level (60 V direct current).
 - The branch circuit overcurrent protection must be rated 20A.
-

Hot-plug power supply calculations

For hot-plug power supply specifications and calculators to determine electrical and heat loading for the server, refer to the HP Enterprise Configurator website (<http://h30099.www3.hp.com/configurator/>).

Acronyms and abbreviations

ABEND

abnormal end

AMP

Advanced Memory Protection

ASR

Automatic Server Recovery

CSR

Customer Self Repair

FBWC

flash-backed write cache

IEC

International Electrotechnical Commission

iLO

Integrated Lights-Out

IML

Integrated Management Log

NMI

non-maskable interrupt

NVRAM

non-volatile memory

PCIe

peripheral component interconnect express

PSP

ProLiant Support Pack

RBSU

ROM-Based Setup Utility

SAS

serial attached SCSI

SFF

small form-factor

SIM

Systems Insight Manager

UID

unit identification

USB

universal serial bus

Documentation feedback

HP is committed to providing documentation that meets your needs. To help us improve the documentation, send any errors, suggestions, or comments to Documentation Feedback (<mailto:docsfeedback@hp.com>). Include the document title and part number, version number, or the URL when submitting your feedback.

Index

A

access panel 28
additional information 69
air baffle 26
ASR (Automatic Server Recovery) 71
Automatic Server Recovery (ASR) 71

B

buttons 74

C

cables 64
cabling 64, 65, 67
cabling, server 64
cautions 25
components 16, 24, 63, 74
components, identification 16, 74
components, system board 80
connectors 74
CSR (customer self repair) 5
customer self repair (CSR) 5

D

diagnostic tools 69, 70, 71
diagnostics utility 70
DIMM slots 79
DIMMs 46
drive blank 34
drives 34, 74, 80
drives, determining status of 80
DVD-ROM drive 33

E

electrostatic discharge 24
environmental requirements 83
environmental specifications 83
expansion boards 43
extending server from rack 27

F

fan blank 35
fan module locations 81
fan modules 36
FBWC cabling 67
FBWC capacitor pack 44
features 74
FlexibleLOM 38
front panel buttons 75
front panel components 74
front video adapter 37

H

hard drive cage 39, 40
hard drive LEDs 80
hard drives, determining status of 80
health driver 71
heatsink 48
hot-plug power supply calculations 86
HP Enterprise Configurator 86
HP Insight Diagnostics 24, 70
HP Insight Diagnostics survey functionality 70
HP Insight Remote Support software 71

I

identifying components 74
illustrated parts catalog 16
IML (Integrated Management Log) 71
Insight Diagnostics 70
Integrated Management Log (IML) 71
internal cables 64
internal USB connector 47

L

LEDs 74
LEDs, front panel 80
LEDs, hard drive 80
LEDs, SAS hard drive 80

M

management tools 69
mechanical components 16

N

NMI jumper 80

P

part numbers 16
PCI riser cage 42
power calculator 86
power requirements 86
power supplies 86
power supply 29, 86
power supply backplane 30, 31
power supply output 86
powering down 26
preparation procedures 26
processor air baffle 41
processors 50

R

rack bezel 29
RBSU (ROM-Based Setup Utility) 69
rear panel buttons 76
rear panel components 76
removal and replacement procedures 24
replacement procedures 24
required tools 24
requirements, environmental 83
requirements, power 86
ROM-Based Setup Utility (RBSU) 69

S

safety considerations 24
safety information 24
server specifications 83, 86
server warnings and cautions 25
specifications 83
specifications, environmental 83
specifications, power 84
specifications, server 83, 86
static electricity 24
symbols on equipment 25
system battery 62
system board 55
system board components 77
system components 19, 74

system maintenance switch 79

T

T-10/T-15 Torx screwdriver 24, 82
telco racks 26
tools 24, 69
TPM (Trusted Platform Module) 63
troubleshooting 69, 73
troubleshooting resources 69, 73
Trusted Platform Module (TPM) 63

U

utilities 69
utilities, deployment 69

W

warnings 25