

PRIMERGY RX300 S5

Options Guide

Comments... Suggestions... Corrections...

The User Documentation Department would like to know your opinion of this manual. Your feedback helps us optimize our documentation to suit your individual needs.

Feel free to send us your comments by e-mail to [email: manuals@ts.fujitsu.com](mailto:manuals@ts.fujitsu.com).

Certified documentation according to DIN EN ISO 9001:2000

To ensure a consistently high quality standard and user-friendliness, this documentation was created to meet the regulations of a quality management system which complies with the requirements of the standard DIN EN ISO 9001:2000.

cognitas. Gesellschaft für Technik-Dokumentation mbH
www.cognitas.de

Copyright and Trademarks

Copyright © 2009 Fujitsu Technology Solutions GmbH.

All rights reserved.

Delivery subject to availability. The right to technical modification is reserved.

All hardware and software names used are trade names and/or trademarks of their respective manufacturers.

Content

1	Preface	7
1.1	Concept and target groups for this manual	7
1.2	Documentation overview	8
1.3	Expansions and conversions	9
1.4	Notational conventions	13
2	Procedure	15
3	Safety instructions	17
4	Preparation	23
4.1	Removing the server from the rack	23
4.2	Opening the server	24
4.3	Removing the air duct	25
4.4	Removing the fan box	26
4.5	Removing the power supply cage	27
5	Main memory	29
5.1	Equipping rules	30
5.2	Extending/replacing the main memory	31
6	Processors	33
6.1	Installing a second processor	33
6.2	Replacing the processor	42
6.3	Replacing the heat sink	45

Contents

7	Accessible drives	47
7.1	Inserting the ServerView Local Service Module	47
7.2	Installing an optical drive	52
7.3	USB tape drive/USB RDX drive	57
7.3.1	Installing a USB drive in a 6x 3.5" variant	57
7.3.1.1	Installing a USB drive in a drive cage	57
7.3.1.2	Installing a USB drive	60
7.3.2	Installing a USB drive in the 8x 2.5" variant	72
7.3.2.1	Installing a USB drive	72
7.3.2.2	Connecting a USB drive	75
8	Expansion cards in the PCI slots	83
8.1	Installing an expansion card	83
8.2	Upgrading a SAS controller	85
9	Battery Backup Unit	89
9.1	BBU-Modul einbauen	89
10	Front VGA port	95
10.1	Installing a front VGA port	95
11	Trusted Platform Module	101
11.1	Installing a TPM-Module	101
12	USB Flash Module	105
12.1	Installing USB Flash Module	105
13	Completion	107
13.1	Installing a fan box	107

13.2	Installing a power supply cage	108
13.3	Inserting the air duct	110
13.4	Closing the server	111
13.5	Installing the server in the rack	112
14	Appendix	115
<hr/>		
14.1	Cable list	115
14.2	Cabling plans	117
14.3	Configuration schema	121
Index	123

1 Preface

The PRIMERGY RX300 S5 rack server is a universal and high-performance platform designed for a whole range of application areas in data center and server farm concepts. The system was developed specifically for configurations with multiple servers (clusters), front-end solutions, e-commerce applications and ERP solutions. The PRIMERGY RX300 S5 is ideal for applications and operational areas that require maximum scalability, performance and availability in a space-saving rack cabinet.

The PRIMERGY RX300 S5 offers a balanced architecture that incorporates next generation main memory (DDR3) and I/O technologies (PCIe Gen2). The backplanes for 6*3.5" and 8*2.5" hard disk drives are already provided for SAS 2.0 and 6 Gbit/s SAS and the chipset prepared for the next generation of 6-core processors. High performance, scalability, impressive reliability and excellent extension options are combined in a powerful design.

The Cool-safe™ cooling concept with improved air flow cooling technology (honeycomb design) ensures the highest possible performance of the processors at work; at the same time, the system is extremely reliable thanks to the reduced heat dissipation.

The server occupies just two height units (HU) in the rack.

Security functions in the *BIOS-Setup* and on the system board protect the data on the server against manipulation. Additional security is provided by the lockable rack door.

1.1 Concept and target groups for this manual

This Options Guide explains how to enhance and upgrade the server.



Installation and removal of hot-plug components is described in the server operating manual.

The actions described in this manual may only be performed by personnel with the appropriate technical training.

1.2 Documentation overview

More information on your PRIMERGY RX300 S5 can be found in the following documents:

- "Quick Start Hardware - PRIMERGY RX300 S5" leaflet (only included as a printed copy)
- "Quick Start Software - Quick Installation Guide" DVD booklet (only included with the PRIMERGY ServerView Suite as a printed copy)
- "Safety notes and other important information" manual
- "Warranty" manual
- "PRIMERGY ServerView Suite Local Service Concept - LSC" manual
- "Returning used devices" manual
- "Helpdesk" leaflet
- Technical manual for the system board D2619
- "PRIMERGY RX300 S5 Server Operating Manual"
- "PRIMERGY RX300 S5 Server Options Guide"
- "D2619 Bios Setup Utility" manual



PRIMERGY manuals are available in PDF format on the PRIMERGY ServerView Suite DVD 2. The PRIMERGY ServerView Suite DVD 2 is part of the PRIMERGY ServerView Suite supplied with every server.

If you no longer have the ServerView Suite DVDs, you can obtain the relevant current versions using the order number U15000-C289.

The PDF files of the manuals can also be downloaded free of charge from the Internet. The overview page showing the online documentation available on the Internet can be found using the URL:

<http://manuals.ts.fujitsu.com>. The PRIMERGY server documentation can be accessed using the *Industry standard servers* navigation option.

Further sources of information:

- PRIMERGY Abbreviations and Glossary on the PRIMERGY ServerView Suite DVD 2
- Manual for the monitor
- Documentation for the boards and drives
- Operating system documentation
- Information files in your operating system

1.3 Expansions and conversions

Second processor

The system board can be upgraded with a second processor. Only processors of the same type may be used on the system board. The second processor must have the same clock frequency and the same cache as the first processor.

Main memory expansion

The system board supports up to 144 GB main memory. There are 18 slots available for the main memory. Each slot can be populated with 2 GB, 4 GB or 8 GB single or dual ranked RDIMM memory modules. The minimum memory configuration is 1 DIMM per system board in Independent Channel Mode.

ECC with memory scrubbing and the Single Device Data Correction (SDDC) function is standard.

There are three modes of operation for the main memory:

- Independent Channel Mode (maximum memory configuration)

The populated memory in the 6 channels (A-F) can be used in full (max. 144 GB).

- Mirrored Channel Mode (maximum security)

Only the populated memory in the 2 channels A and D can be used (max. 48 GB). The 2 channels B and E are for failure protection purposes only. They contain the mirrored data from channels A and D. Channels C and F are not used.

- Spare Channel Mode (high memory configuration with high security)

Only the populated memory in the 4 channels A, B, D and E can be used (max. 96 GB). Channels C and F are for failure protection purposes only. There are different population requirements, depending on the mode of operation.

SAS/SATA RAID controller

The server is available with the following SAS/SATA RAID controllers for operating the internal SAS/SATA hard disk drives:

- Modular RAID 0/1 controller with "Integrated Mirroring Enhanced" (SAS-IME)

RAID levels 0, 1 and 1E are supported for internal hard disk drive configurations.

- Modular RAID 5/6 controller with "MegaRAID functionality" (SAS MegaRAID)

RAID levels 0, 1, 10, 1E, 5, 50, 6 and 60 are supported for internal hard disk drive configurations. As an option, a battery backup unit (BBU) can save the memory content even if the power fails. Cache memory sizes of 256 Mbyte and 512 Mbyte are available.



Further information on SAS/SATA RAID controllers is provided in the "Modular RAID Controller Installation Guide" (on PRIMERGY ServerView Suite DVD 2 under *Industry Standard Servers - Expansion Cards - Storage Adapters - LSI RAID / SCSI Controllers*).

Further information on other SAS/SATA RAID controllers (e.g. for operating external SAS/SATA hard disk drives or tape drives) is available on the PRIMERGY ServerView Suite DVD 2 under *Industry Standard Servers - Expansion Cards - Storage Adapters - LSI RAID / SCSI Controllers*.

Additional accessible drives

A number of mounting locations are available:

- one bay for a ServerView Local Service Panel (optional) or a ServerView Local Service Display (optional)
- one bay for a slimline optical drive (option)



The accessible drives integrated in these bays cannot be replaced during operation.

In a 6x 3.5" or 8x 2.5" HDD configuration, a USB magnetic tape drive or a USB RDX drive can be optionally installed in the right drive cage.



In a 6x 3.5" HDD configuration, two bays are occupied in the drive cage. These bays are no longer available for HDD modules. The magnetic tape drive or the RDX drive cannot be replaced during operation.

ServerView Local Service Display/Panel (alphanumeric system display)

You can also fit your server with a ServerView Local Service Panel/Display, which enables you to identify the type of component affected by the error directly on the server (for more information, see the "PRIMERGY ServerView Suite Local Service Concept - LSC" manual on the PRIMERGY ServerView Suite DVD 2).

Customer Self Service (CSS)

The Fujitsu Technology Solutions Customer Self Service (CSS) concept enables you to identify and replace the affected component yourself in the case of certain error scenarios.

In the CSS concept, you can replace the following components yourself in the event of an error:

- Hot-plug hard disk drives
- Hot-plug power supply units
- Memory modules
- Hot-plug system fan
- Expansion cards

CSS indicators on the control panel and on the back of the PRIMERGY server provide you with information if a CSS event arises (for more information on the behavior of these indicators, see the operating manual and the "PRIMERGY ServerView Suite Local Service Concept - LSC" manual on the PRIMERGY ServerView Suite DVD 2).

You can also fit your server with a ServerView Local Service Panel, which enables you to identify the type of component affected by the error directly on the server (for more information, see the "PRIMERGY ServerView Suite Local Service Concept - LSC" manual on the PRIMERGY ServerView Suite DVD 2).

In addition, CSS errors are displayed in the ServerView Operations Manager - the server management software from Fujitsu Technology Solutions.

In the event of errors, the ServerView Operations Manager refers you directly to the affected component and its order information in the Illustrated Spares catalog of the server in question.

Hard disk drives

The server has the following hard disk drive configurations:

- 3.5" SAS/SATA hard disk drives: up to six HDD modules, each with a 3.5" SAS/SATA hard disk drive.
- 2.5" SAS hard disk drives: up to eight HDD modules, each with a 2.5" SAS hard disk drive.
- 2.5" SAS hard disk drives: up to twelve HDD modules, each with a 2.5" SAS hard disk drive.

The module is connected to the SAS/SATA backplane without cables. This allows HDD modules to be plugged in or pulled out easily (for further details, see chapter "Hot-plug hard disk drives" in the operating manual).

The hard disk subsystem is designed for SAS/SATA, each with one channel for each hard disk drive.

If the server has a RAID configuration, the HDD modules can be exchanged during operation (hot-swap).



The three basic configurations are variants that cannot be converted into other variants on site.

Additional controllers

The system board offers seven PCIe slots: Slots 1, 2, 3, 4 and 5 are PCIe x4 slots. Slots 7 and 8 are x8 slots that have a frequency of 133 MHz. If slot 2 or 4 remains unpopulated, slot 3 or 5 can be run x8.

Additional battery (option)

Two controllers can each have an additional battery installed.

USB Flash Module (UFM) (option)

The system board is equipped with a UFM slot by the manufacturer.



The "internal USB stick" and "UFM" slots must not be used in parallel. Either an internal USB stick **or** a UFM may be used.

Trusted Platform Module (TPM)

A Trusted Platform Module (TPM) for safer storage of keys can be implemented as an option. This module enables programs from third party manufacturers to store key information (e.g. drive encryption using Windows Bitlocker Drive Encryption).

The TPM is activated via the BIOS system (for more information, refer to the Fujitsu Technology Solutions BIOS manual).





CAUTION!

- When using the TPM, note the program descriptions provided by the third party manufacturers.
- You must also create a backup of the TPM content. To do this, follow the third party manufacturer's instructions. Without this backup, if the TPM or the system board is faulty you will not be able to access your data.
- If a failure occurs, please inform your service about the TPM activation before it takes any action, and be prepared to provide them with your backup copies of the TPM content.

1.4 Notational conventions

The following notational conventions are used in this manual:

<i>Text in italics</i>	indicates commands or menu items.
"Quotation marks"	indicate names of chapters and terms that are being emphasized.
▶	describes activities that must be performed in the order shown.
 CAUTION!	pay particular attention to texts marked with this symbol. Failure to observe this warning may endanger your life, destroy the system or lead to the loss of data.
	indicates additional information, notes and tips.

2 Procedure



CAUTION!

- The actions described in this manual shall be performed by technical specialists. A technical specialist is a person who is trained to install the server including hardware and software.
 - Repairs to the device that do not relate to CSS failures shall be performed by service personnel. Please note that unauthorized interference with the system will void the warranty and exempt the manufacturer from all liability.
 - Any failure to observe the guidelines in this manual, and any improper repairs could expose the user to risks (electric shock, energy hazards, fire hazards) or damage the equipment.
- ▶ First of all, carefully read the safety instructions in the ["Safety instructions" on page 17](#).
 - ▶ Make sure that all necessary manuals (see the section ["Documentation overview" on page 8](#)) are available; print the PDF files if required. Most importantly, you will need the operating manual for the server and the technical manual for the system board.
 - ▶ Shut the server down correctly, switch it off, disconnect the power plugs and open the server as described in the [chapter "Preparation" on page 23](#).
 - ▶ Carry out the expansion or upgrade of your server as described in the pertinent chapter.
-  Installation and removal of the hot-plug components are described in the operating manual.
- ▶ Close the server, connect it to the power outlet, and switch it on as described in the [chapter "Completion" on page 107](#).
 - ▶ Start the operating system and make the appropriate configuration if necessary (see the operating manual).

3 Safety instructions



The following safety instructions are also provided in the manual "Safety notes and other important information".

This device meets the relevant safety regulations for IT equipment. If you have any questions about whether you can install the server in the intended environment, please contact your sales outlet or our customer service team.



CAUTION!

- The actions described in this manual shall be performed by technical specialists. A technical specialist is a person who is trained to install the server including hardware and software.
- Repairs to the device that do not relate to CSS failures shall be performed by service personnel. Please note that unauthorized interference with the system will void the warranty and exempt the manufacturer from all liability.
- Any failure to observe the guidelines in this manual, and any improper repairs could expose the user to risks (electric shock, energy hazards, fire hazards) or damage the equipment.

Before starting up



CAUTION!

- During installation and before operating the device, observe the instructions on environmental conditions for your device.
- If the device is brought in from a cold environment, condensation may form both inside and on the outside of the device.

Wait until the device has acclimatized to room temperature and is absolutely dry before starting it up. Material damage may be caused to the device if this requirement is not observed.

- Transport the device only in the original packaging or in packaging that protects it from knocks and jolts.

Installation and operation



CAUTION!

- This unit should not be operated in ambient temperatures above 35 °C.
- If the unit is integrated into an installation that draws power from an industrial power supply network with an IEC309 connector, the power supply's fuse protection must comply with the requirements for non-industrial power supply networks for type A connectors.
- The unit automatically adjusts itself to a mains voltage in a range of 100 V - 240 V. Ensure that the local mains voltage lies within these limits.
- This device must only be connected to properly grounded shock-proof sockets or insulated sockets of the rack's internal power supply with tested and approved power cables.
- Ensure that the device is connected to a grounded shockproof socket close to the device.



CAUTION!

- Ensure that the power sockets on the device and the grounded shockproof sockets are freely accessible.
- The On/Off button or the main power switch (if present) does not isolate the device from the mains power supply. To disconnect it completely from the mains power supply, unplug all network power plugs from the grounded shockproof sockets.
- Always connect the server and the attached peripherals to the same power circuit. Otherwise you run the risk of losing data if, for example, the server is still running but a peripheral device (e.g. memory subsystem) fails during a power outage.
- Data cables must be adequately shielded.
- The EN 50173 and EN 50174-1/2 standards apply for LAN cabling. The minimum requirement is the use of a category 5 screened LAN cable for 10/100 Mbit/s Ethernet, or a category 5e cable for Gigabit Ethernet. The requirements from the ISO/IEC 11801 specification must also be met.
- Route the cables in such a way that they do not create a potential hazard (make sure no-one can trip over them) and that they cannot be damaged. When connecting the server, refer to the relevant instructions in this manual.
- Never connect or disconnect data transmission lines during a storm (risk of lightning strike).
- Make sure that no objects (e.g. jewelry, paperclips etc.) or liquids can get inside the server (risk of electric shock, short circuit).
- In emergencies (e.g. damaged casing, controls or cables, penetration of liquids or foreign bodies), switch off the server immediately, remove all power plugs and contact your sales outlet or customer service team.

**CAUTION!**

- Proper operation of the system (in accordance with IEC 60950-1/ EN 60950-1) is only ensured if the casing is completely assembled and the rear covers for the installation slots have been fitted (electric shock, cooling, fire protection, interference suppression).
- Only install system expansions that satisfy the requirements and rules governing safety and electromagnetic compatibility and those relating to telecommunication terminals. If you install other expansions, they may damage the system or violate the safety regulations. Information on which system expansions are approved for installation can be obtained from our customer service center or your sales outlet.
- The components marked with a warning notice (e.g. lightning symbol) may only be opened, removed or exchanged by authorized, qualified personnel. Exception: CCS components can be replaced.
- The warranty is void if the server is damaged during installation or replacement of system expansions.
- Only set screen resolutions and refresh rates that are specified in the operating manual for the monitor. Otherwise, you may damage your monitor. If you are in any doubt, contact your sales outlet or customer service center.

Batteries**CAUTION!**

- Incorrect replacement of batteries may result in a risk of explosion. The batteries may only be replaced with identical batteries or with a type recommended by the manufacturer (see the technical manual for the system board).
- Replace the lithium-battery on the system board in accordance with the instructions in the technical manual for the system board.

Working with CDs/DVDs and CD/DVD drives

When working with devices with CD/DVD drives, these instructions must be followed.



CAUTION!

- Only use CDs/DVDs that are in perfect condition in your server's CD/DVD drive, in order to prevent data loss, equipment damage and injury.
- Check each CD/DVD for damage, cracks, breakages etc. before inserting it in the drive.

Note that any additional labels applied may change the mechanical properties of a CD/DVD and cause imbalance.

Damaged and imbalanced CDs/DVDs can break at high drive speeds (data loss).

Under certain circumstances, sharp CD/DVD fragments can pierce the cover of the CD/DVD drive (equipment damage) and can fly out of the device (danger of injury, particularly to uncovered body parts such as the face or neck).



You can prevent mechanical damage and damage to the CD/DVD drive, as well as premature CD/DVD wear, by observing the following suggestions:

- Only insert CDs/DVDs in the drive when needed and remove them after use.
- Store the CDs/DVDs in suitable sleeves.
- Protect the CDs/DVDs from exposure to heat and direct sunlight.

Laser information

The CD/DVD drive complies with IEC 60825-1 laser class 1.



CAUTION!

The CD/DVD drive contains a light-emitting diode (LED), which under certain circumstances produces a laser beam stronger than laser class 1. Looking directly at this beam is dangerous.

Never remove parts of the CD/DVD drive casing!

Modules with electrostatic-sensitive components

Systems and components that might be damaged by electrostatic discharge (ESD) are marked with the following label:

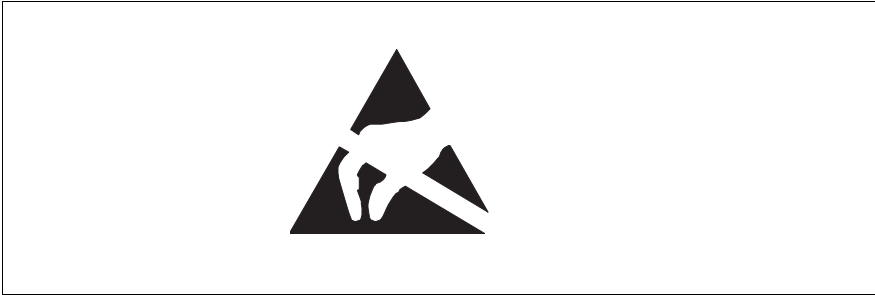

Figure 1: ESD label

When you handle components fitted with ESDs, you must observe the following points under all circumstances:

- Remove the power plug before installing or removing components containing ESDs.
- You must always discharge yourself of static charges (e.g. by touching a grounded object) before working.
- The equipment and tools you use must be free of static charges.
- Only touch the components at the positions highlighted in green (touch points).
- Do not touch any exposed pins or conductors on a component.
- Use a grounding cable designed for this purpose to connect yourself to the system unit as you install components.
- Place all components on a static-safe base.



You will find a detailed description for handling ESD components in the relevant European or international standards (DIN EN 61340-5-1, ANSI/ESD S20.20).

4 Preparation



CAUTION!

Please note the safety instructions in [chapter "Safety instructions" on page 17](#)

4.1 Removing the server from the rack

- ▶ Terminate all applications and shut down the server correctly.
- ▶ If your operating system has not switched off the server, press the on/off button.
- ▶ Pull all power connectors out of the power outlets.

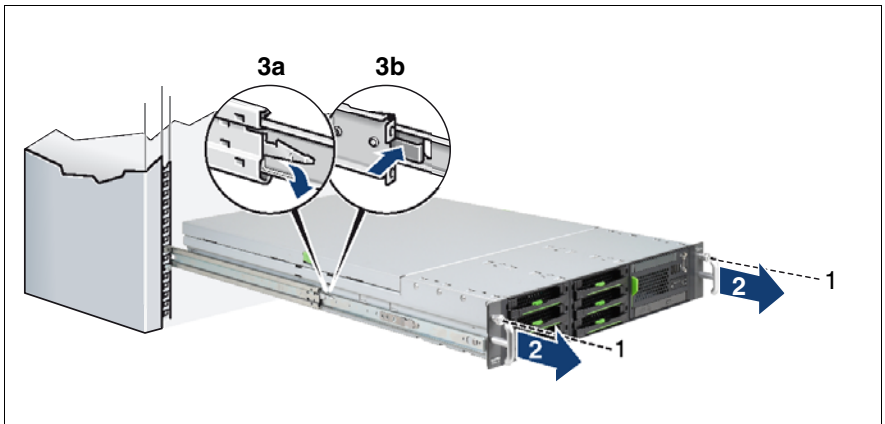

Figure 2: Knurled screws loosened and the server pulled out

- ▶ Loosen the two knurled screws (1) and pull the server as far as possible out of the rack (2).
- ▶ Disconnect all cables on the rear side of the server.



Depending on the accessibility of the server in the rack cabinet, it may be helpful to remove the server from the rack cabinet. If you do not want to remove the server from the rack cabinet, please skip the next step.

Release the locking mechanism of both rails - see (3a) for fully extending rails and (3b) for partially extending rails.

- ▶ Lift the server off the rails.

**CAUTION!**

At least two people are needed to lift the server out of the rack cabinet.

4.2 Opening the server



Figure 3: Removing the top cover

- ▶ Press the two locks down.
- ▶ Slide the cover back and take it off.

4.3 Removing the air duct

i You only need to remove the air duct if you want to work in the area of the expansion cards, main memory or processors.

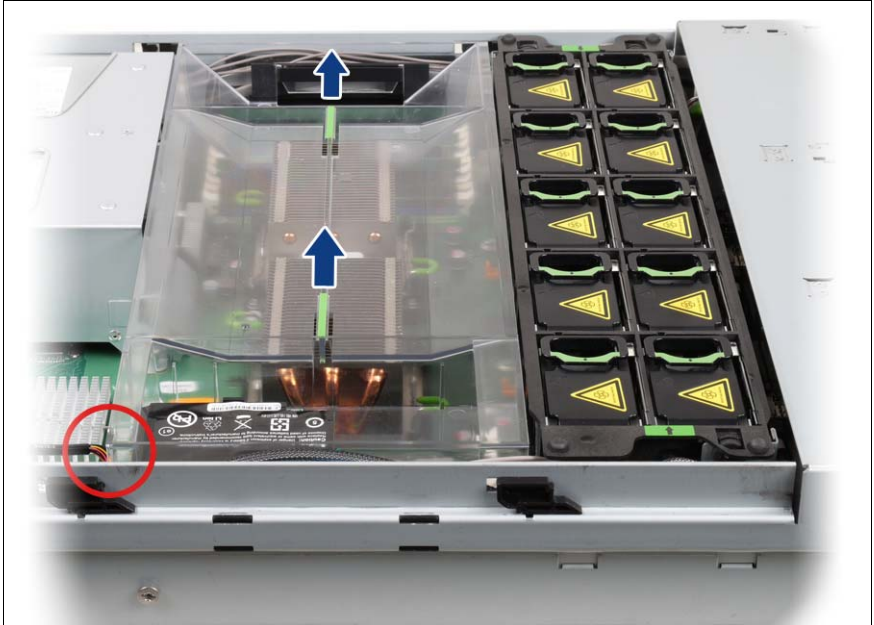

Figure 4: Removing the air duct over the main memory and processors

- ▶ Take hold of the air duct by the green touch points, and lift it up and off.

i If you have installed controllers with a BBU: Pay attention to the BBU cable(s) (see circle) when lifting off the air duct! If you want to remove the air duct from the server completely, first disconnect the BBU cable/cables.

4.4 Removing the fan box

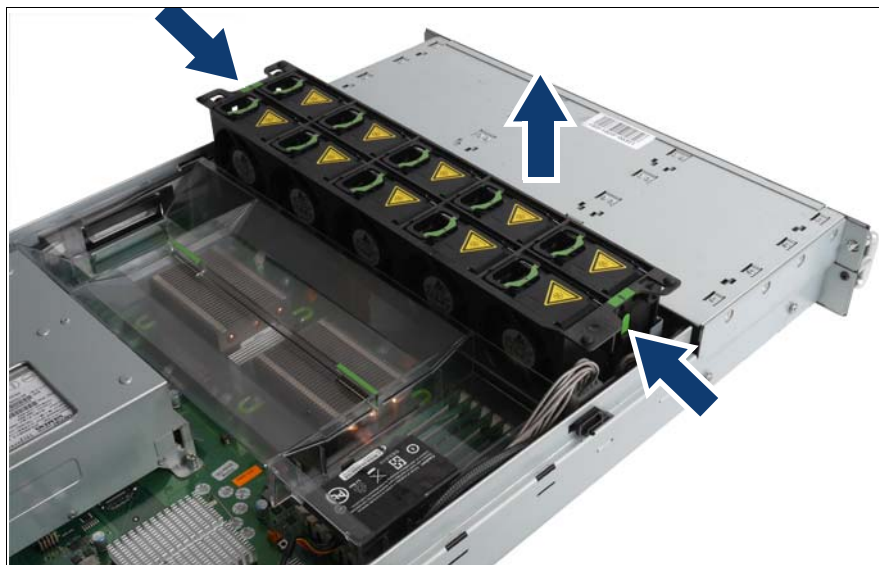

Figure 5: Removing the fan box

- ▶ Push in the fan box locks on the right and left-hand side.
- ▶ Pull the fan box straight up and out.
- ▶ Place the fan box on the plate over the drives.

4.5 Removing the power supply cage

Removing the power supply and dummy module

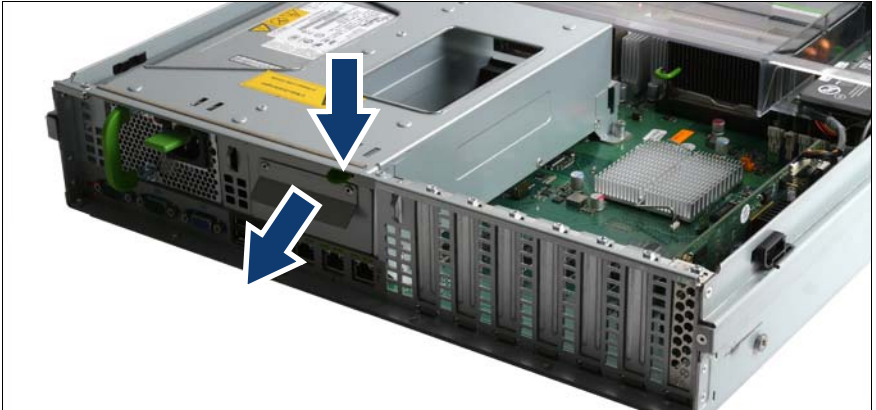

Figure 6: Removing the power supply dummy module

- ▶ Unlock the dummy module and pull it out.



Figure 7: Removing the power supply module

- ▶ Unlock the power supply module and pull it out.

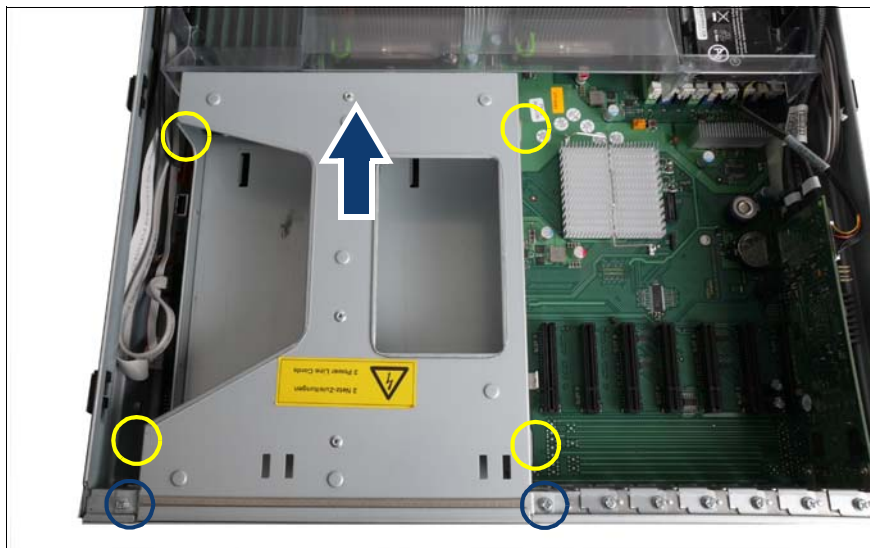

Figure 8: Removing the power supply cage

- ▶ Remove the two screws (blue circles) on the upper rear side.
- ▶ Loosen the four captive screws (yellow circles).
- ▶ Remove the power supply cage by lifting it straight up to avoid damaging the plugs on the system board.

5 Main memory



CAUTION!

Please note the safety instructions in [chapter "Safety instructions" on page 17](#).

The system board supports up to 144 GB main memory. There are 18 slots available for the main memory. Each slot can be populated with 2 GB, 4 GB or 8 GB single or dual ranked RDIMM memory modules. The minimum memory configuration is 1 DIMM per system board in Independent Channel Mode.

ECC with memory scrubbing and the Single Device Data Correction (SDDC) function is standard.



You can find a more detailed description of the main memory population in the technical manual for the system board D2619.



If you want to alter the Memory Channel Mode during an upgrade, the setting must be changed in the BIOS setup. You can find a more detailed description in the BIOS manual for the system board D2619.

5.1 Equipping rules

Equipping the modules

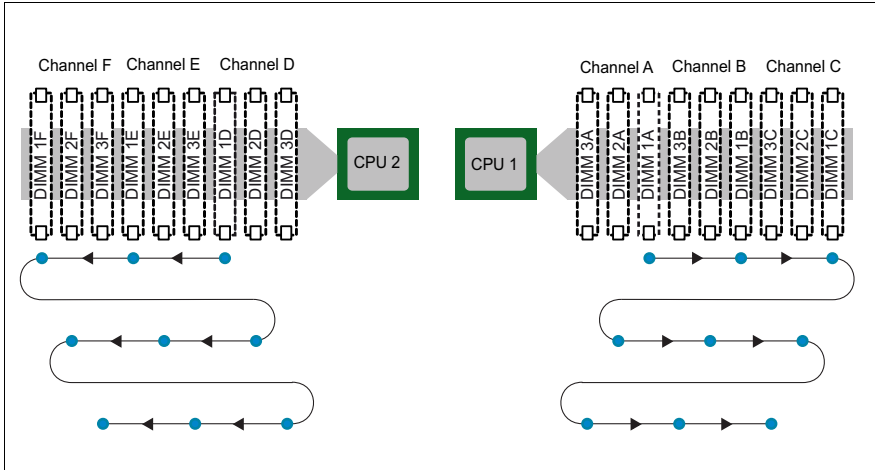

Figure 9: Configuring the main memory in channels and slots

The arrows in [figure 9](#) show the order in which the slots must be populated.

- The memory modules are arranged in 6 channels (A-F), and each channel has three slots (1-3).
- Channels A-C are controlled by CPU 1, and channels D-F are controlled by CPU 2.
- There is only support for x4 registered DIMMs with ECC.

There are three modes of operation for the main memory:

- Independent Channel Mode (maximum memory configuration)

The populated memory in the 6 channels (A-F) can be used in full (max. 144 GB).

- Mirrored Channel Mode (maximum security)

Only the populated memory in the 2 channels A and D can be used (max. 48 GB). The 2 channels B and E are for failure protection purposes only. They contain the mirrored data from channels A and D. Channels C and F are not used.

- Spare Channel Mode (high memory configuration with high security)
Only the populated memory in the 4 channels A, B, D and E can be used (max. 96 GB). Channels C and F are for failure protection purposes only.

Depending on the mode of operation there are different population requirements.

i You can find more information in the BIOS setup manual and the technical manual for the system board D2619.

5.2 Extending/replacing the main memory

- ▶ Open the server as described in [chapter "Preparation" on page 23](#).
- ▶ Remove the air duct over the main memory (see ["Removing the air duct" on page 25](#)).

Removing a memory module

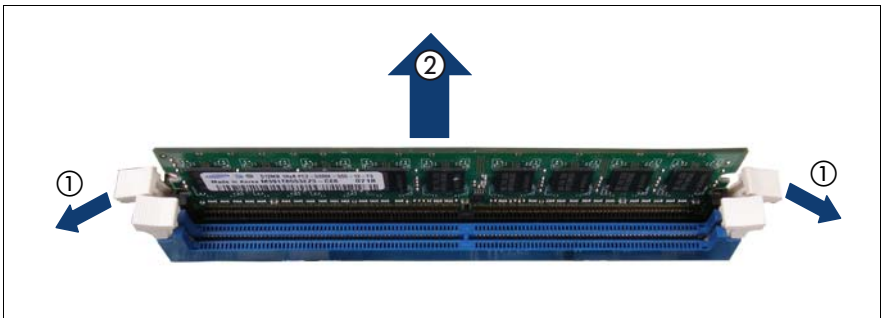

Figure 10: Removing a memory module

- ▶ Press the holders on either side of the mounting location concerned outward (1).
- ▶ Pull the memory module out of the slot (2).

Inserting a memory module



CAUTION!

Please note the equipping rules in the technical manual for the system board D2619.

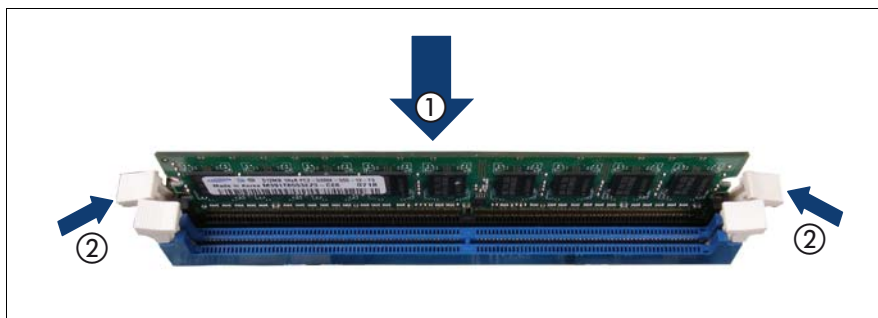

Figure 11: Inserting a memory module

- ▶ Carefully press the memory module into the slot (1) until the fastening tabs on both sides of it engage (2).

Pay attention to the plug coding.

Replacing the air duct and closing the server

- ▶ Insert the air duct back into the server (see [section "Inserting the air duct" on page 110](#)).
- ▶ Return the housing cover to its position (see [section "Closing the server" on page 111](#)).
- ▶ Close the server, connect it to the power outlet, and switch it on as described in the [chapter "Completion" on page 107](#).

6 Processors



CAUTION!

Please note the safety instructions in [chapter "Safety instructions" on page 17](#).



CAUTION!

Processors are modules which can react extremely sensitively to electrostatic discharges and which must therefore always be handled with care. After removing the processor from its protective sleeve or socket, place it with its smooth side down on a non-conducting, antistatic surface. Never push a processor over a surface.

6.1 Installing a second processor

The system board can be upgraded with a second processor. The upgrade kit consists of a processor and a heat sink.



CAUTION!

Only identic processors may be used on the system board. Both processors must have the same clock frequency and the same cache. For dual operation, use a suitable multiprocessor operating system.



When you install the CPU W5590 you must always install the provided heat sink. Install the heat sink as described in the sections ["Installing the heat sink" on page 40](#) and ["Replacing the heat sink" on page 45](#).

- ▶ Open the server as described in [chapter "Preparation" on page 23](#).
- ▶ Lift the air duct over the main memory up and off (see ["Removing the air duct" on page 25](#)).

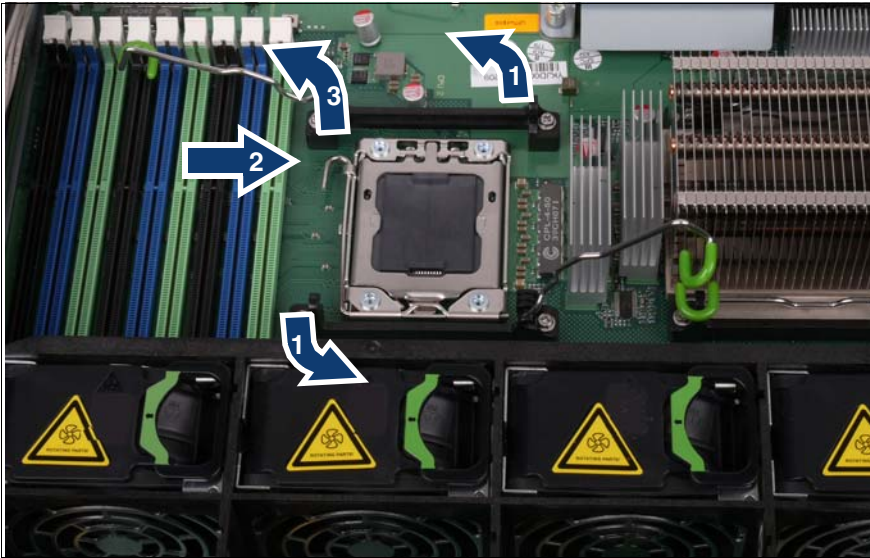

Figure 12: Opening the processor cover

- ▶ Push the two heat sink retention levers in, unlock them, and swing them open.
- ▶ Open the socket release lever and swing it up as far as possible.

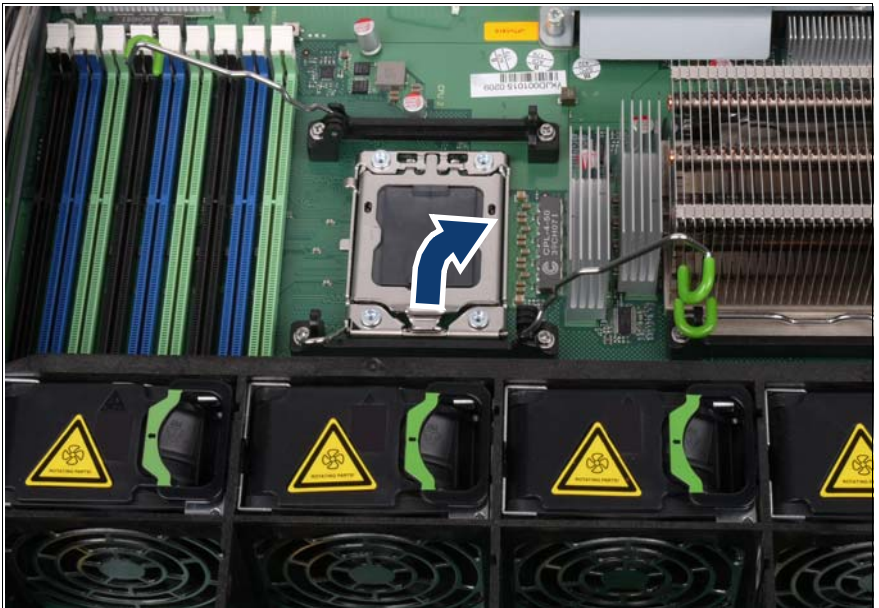

Figure 13: Opening the processor holder

- ▶ Open the processor holder.

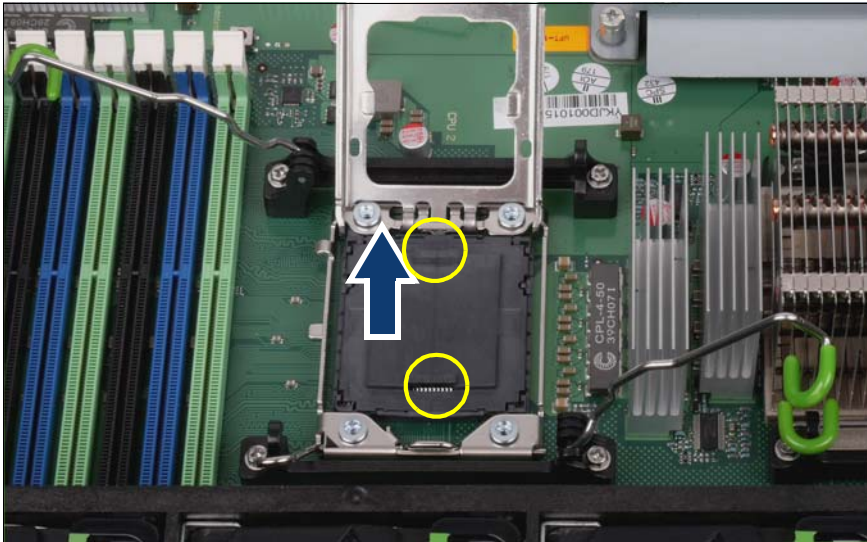

Figure 14: Removing the socket cover

- ▶ Take hold of the socket cover by the handles. Lift the socket cover straight up and off.



CAUTION!

If the socket cover is tilted when it is lifted off, the contact springs of the processor socket will be damaged.

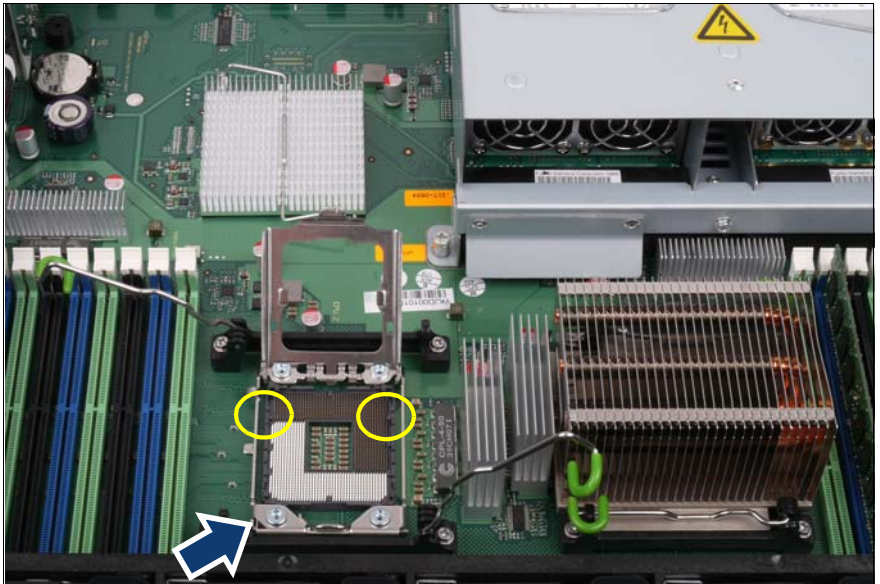

Figure 15: Slot for second CPU, socket coding and marking



CAUTION!

The processor can only be installed in one particular direction. Pay attention to the marking on one of the corners and the two socket codings.

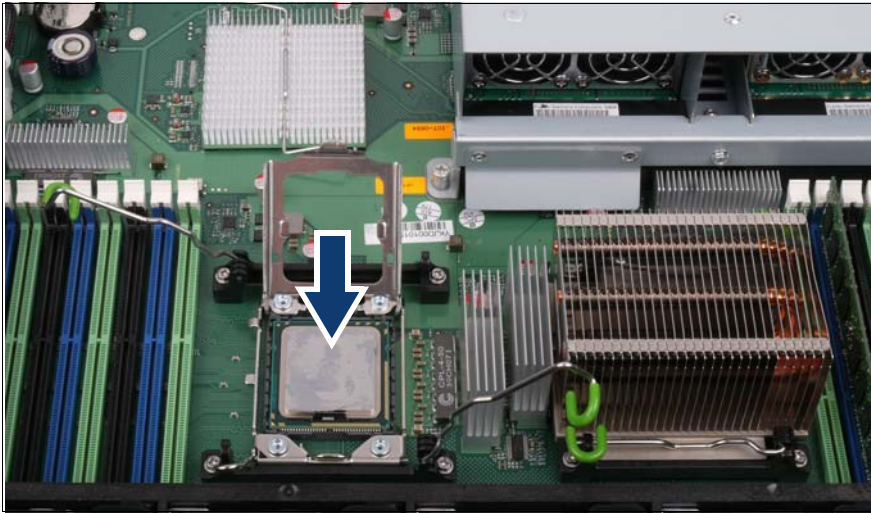

Figure 16: Inserting the processor

- ▶ Position the new processor above the socket, and press it horizontally into the socket.



CAUTION!

The processor can only be installed in one particular direction. Note the marking on one of the corners.



CAUTION!

If the processor is tilted when it is inserted, the contact springs of the processor socket will be damaged.

- ▶ Lock the processor into the socket by closing the processor holder and returning the clip to its original position.

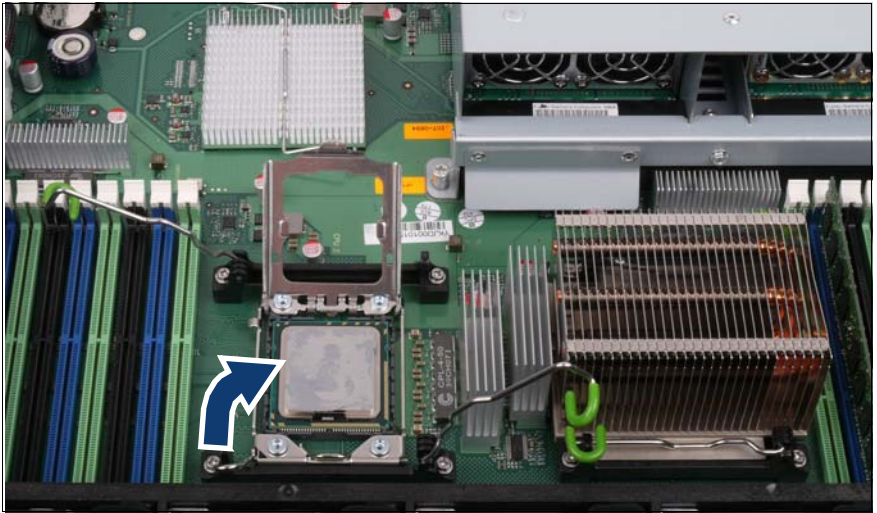

Figure 17: Closing the processor holder

- ▶ Close the socket release lever.

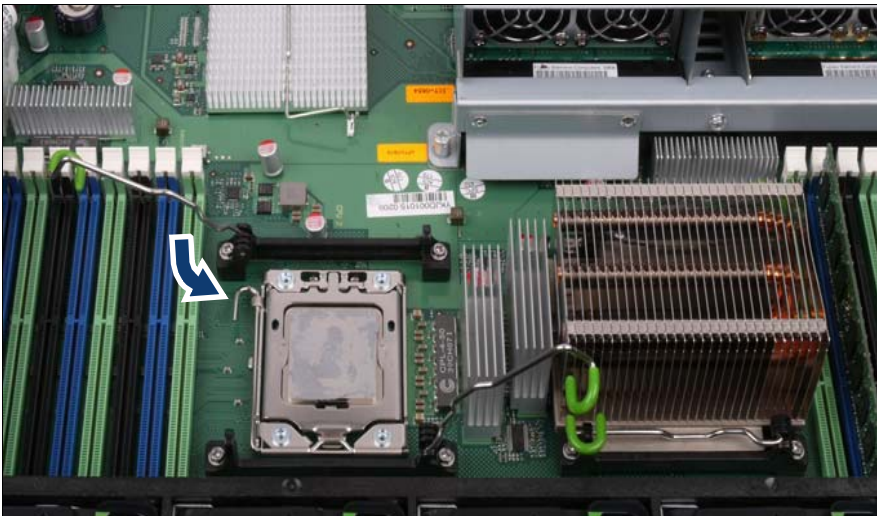

Figure 18: Engaging the socket release lever

- ▶ Engage the socket release lever.

Installing the heat sink

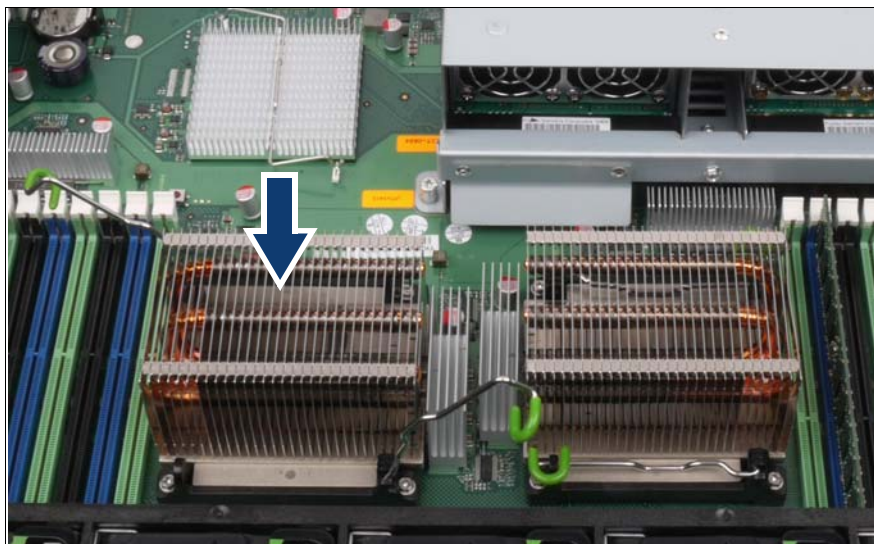

Figure 19: Installing the heat sink

- ▶ Remove the protective cover on the underside of the heat sink.
 - i** When doing so, do not touch the thermal paste on the underside of the heat sink.
- ▶ Place the heat sink on the processor.

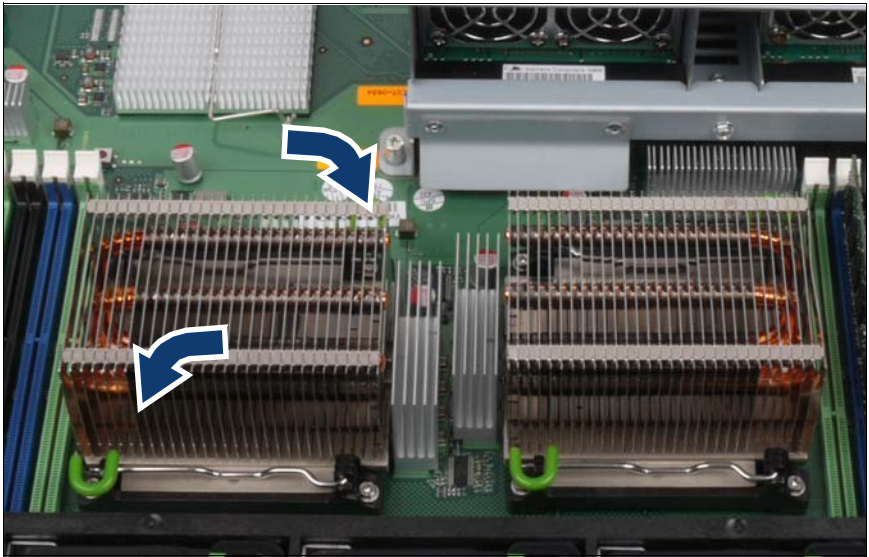

Figure 20: Closing the heat sink retention levers

- ▶ Close the two heat sink retention levers at the same time.
- ▶ Engage the two heat sink retention levers.



CAUTION!

Never install a processor without a heat sink. Doing so may cause the processor to overheat. This will switch the system off and damage the processor.

- ▶ Replace the air duct over the memory and processors (see ["Inserting the air duct" on page 110](#)).
- ▶ Close the server, connect it to the power outlet, and switch it on as described in the [chapter "Completion" on page 107](#).

6.2 Replacing the processor



CAUTION!

Only identical processors may be used on the system board. The second processor must have the same clock frequency and the same cache as the first processor. For dual operation, use a suitable multiprocessor operating system.



When you install the CPU W5590 you must always install the provided heat sink. Install the heat sink as described in the sections ["Installing the heat sink" on page 40](#) and ["Replacing the heat sink" on page 45](#).

- ▶ Open the server as described in [chapter "Preparation" on page 23](#).
- ▶ Remove the air duct over the main memory and processors (see [section "Removing the air duct" on page 25](#)).

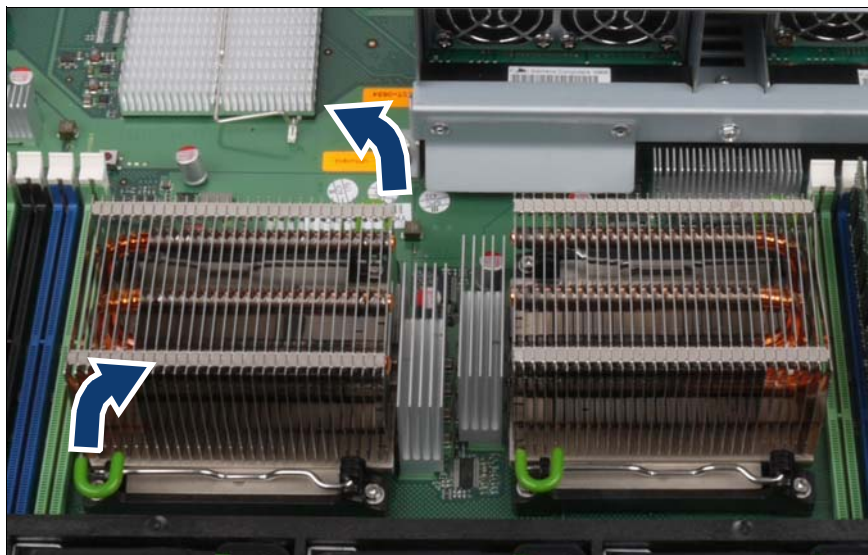

Figure 21: Removing the heat sink

- ▶ Open the two heat sink retention levers at the same time.
- ▶ Loosen the heat sink by turning it back and forth and then lift it out.
- ▶ Remove the residual thermal paste from the underside of the heat sink.
- ▶ Clean the underside of the heat sink using a lint-free cloth.

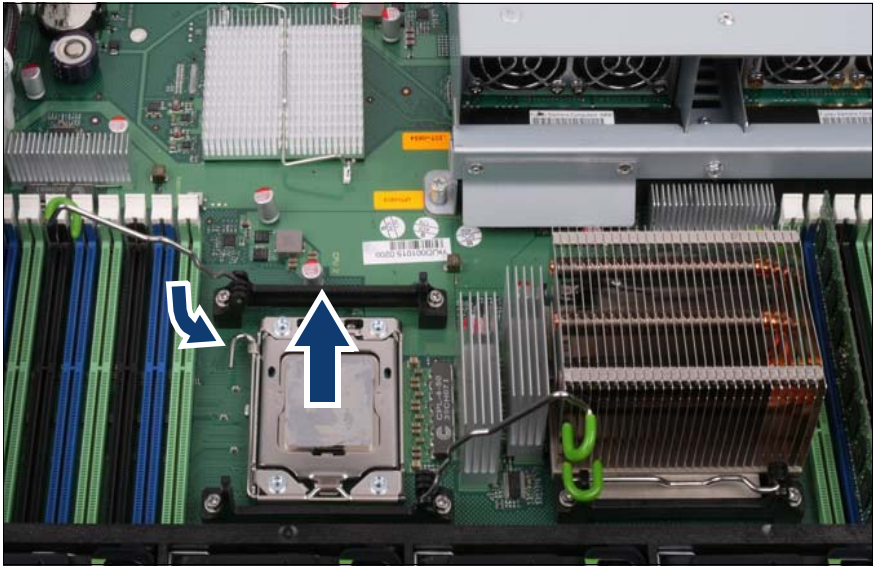

Figure 22: Disengaging the socket release lever

- ▶ Open the socket release lever and swing it up as far as possible.
- ▶ Then open the socket cover.
- ▶ Carefully lift the installed processor horizontally up and out of the socket.

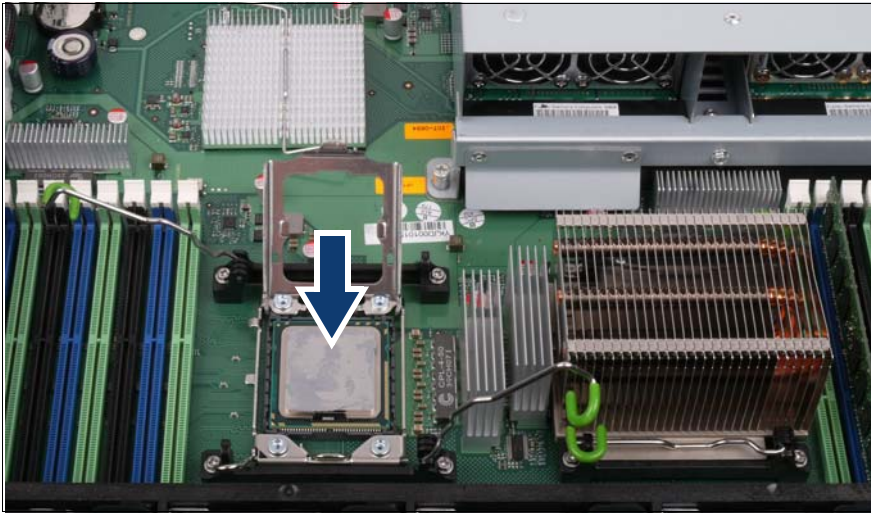

Figure 23: Inserting the processor

- ▶ Position the new processor over the socket and then carefully press it into the socket.



CAUTION!

The processor can only be installed in one particular direction. Pay attention to the marking on one of the corners and the socket coding. To avoid damaging the connections (pins) or the processor, do not force it into the socket.

- ▶ Lock the processor into the socket by closing the socket cover and returning the socket release lever to its original position.
- ▶ Apply a small amount of thermal paste to the upper side of the new processor.
- ▶ Ensure that the thermal paste is spread thinly and evenly. Refer to the instruction sheet supplied with the thermal paste.
- ▶ Place the heat sink on the processor socket (see ["Installing the heat sink" on page 40](#)).

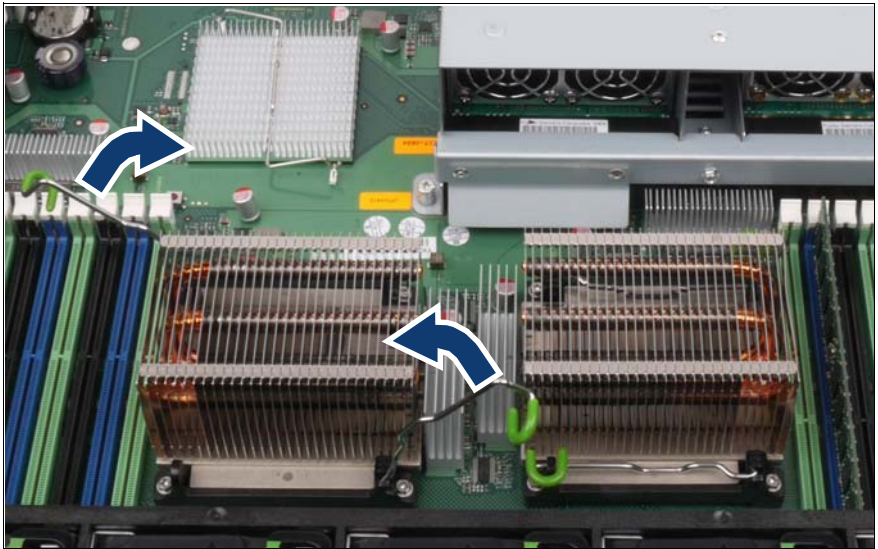

Figure 24: Installing the heat sink

- ▶ Close the two heat sink retention levers at the same time.
- ▶ Replace the air duct over the main memory (see [section "Inserting the air duct" on page 110](#)).
- ▶ Close the server, connect it to the power outlet, and switch it on as described in the [chapter "Completion" on page 107](#).

6.3 Replacing the heat sink

- ▶ Open the server as described in [section "Opening the server" on page 24](#).
- ▶ Remove the air duct over the main memory and processors (see [section "Removing the air duct" on page 25](#)).
- ▶ Open the two heat sink retention levers at the same time (see [section "Replacing the processor" on page 42](#)).
- ▶ Loosen the heat sink by turning it back and forth and then lift it out.
- ▶ Clean the upper side of the processor using a lint-free cloth.
- ▶ Remove the protective cover from the new heat sink.



When doing so, do not touch the thermal paste on the underside of the heat sink.

- ▶ Place the heat sink on the processor socket (see [section "Replacing the processor" on page 42](#)).
- ▶ Close the two heat sink retention levers at the same time.
- ▶ Replace the air duct over the main memory (see ["Inserting the air duct" on page 110](#)).

7 Accessible drives



CAUTION!

Please note the safety instructions in [chapter "Safety instructions" on page 17](#)



There are two free slots available for accessible drives. 5.25-inch x 0.5-inch slot for an optical drive and one bay for a USB magnetic tape drive or USB RDX drive.

7.1 Inserting the ServerView Local Service Module

The ServerView Local Service Panel and ServerView Local Service Display are optional extra modules for PRIMERGY series servers. The display field allows you to read status reports directly on the server. These status reports provide you with information about the system and inform you of hardware errors (e.g. fan failure or excess voltage at the CPU).

The ServerView Local Service Panel or ServerView Local Service Display can be pulled out like a drawer. You can also swing the display field downward.



Figure 25: ServerView Local Service Display and ServerView Local Service Panel

The ServerView Local Service Panel or ServerView Local Service Display can be installed in the empty 3.5"/0.5" bay.

i The installation of the ServerView Local Service Display is depicted below. The ServerView Local Service Panel is installed in the same way.

- ▶ Open the server as described in [section "Opening the server" on page 24](#).
- ▶ Remove the fan box. See [section "Removing the fan box" on page 26](#)

Removing the dummy module

i If you want to upgrade from the Local Service Panel to the Local Service Display, remove the Local Service Panel in the same way as the dummy module, and remove the cable when you have pulled the Local Service Panel right out.

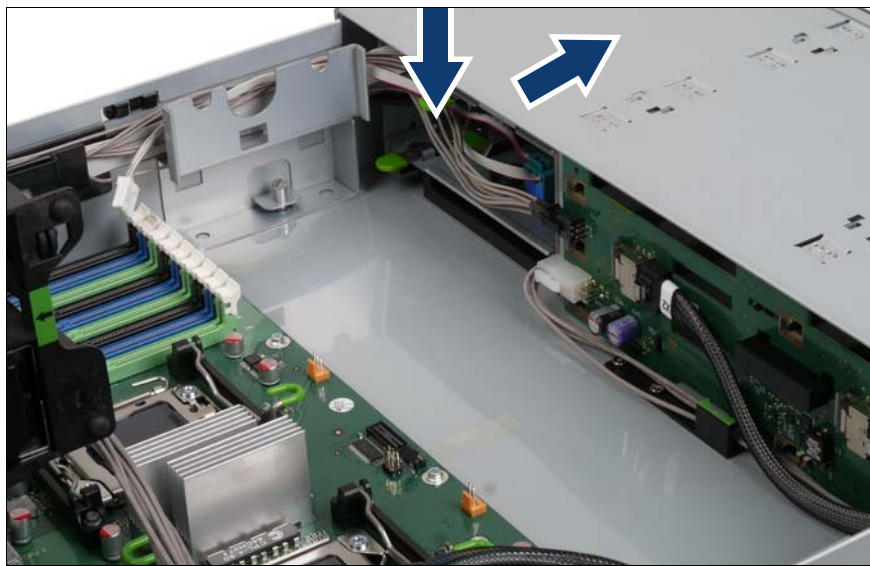

Figure 26: Unlocking the dummy module

- ▶ Unlock the dummy module.
- ▶ Push the dummy module frontward.

i Carefully push the dummy module out horizontally to avoid damaging the EMC springs.



Figure 27: Removing the dummy module

- ▶ Pull out the dummy module frontward.



Figure 28: Connecting the Local View Service Module

- ▶ Thread the cable through the bay to the front.
- ▶ Connect the cable to the ServerView Local Service Display.



Figure 29: Inserting the ServerView Local Service Module



Carefully insert the ServerView Local Service Module horizontally to avoid damaging the EMC springs.

- ▶ Push the ServerView Local Service Module right in.



Further information on usage and display modes is provided in the documentation for the ServerView Local Service Panel or ServerView Local Service Display.

- ▶ Replace the fan box (see [section "Installing a fan box" on page 107](#)).
- ▶ Close the server, connect it to the power outlet, and switch it on as described in the [section "Closing the server" on page 111](#).

7.2 Installing an optical drive

- ▶ Open the server as described in [chapter "Preparation" on page 23](#).

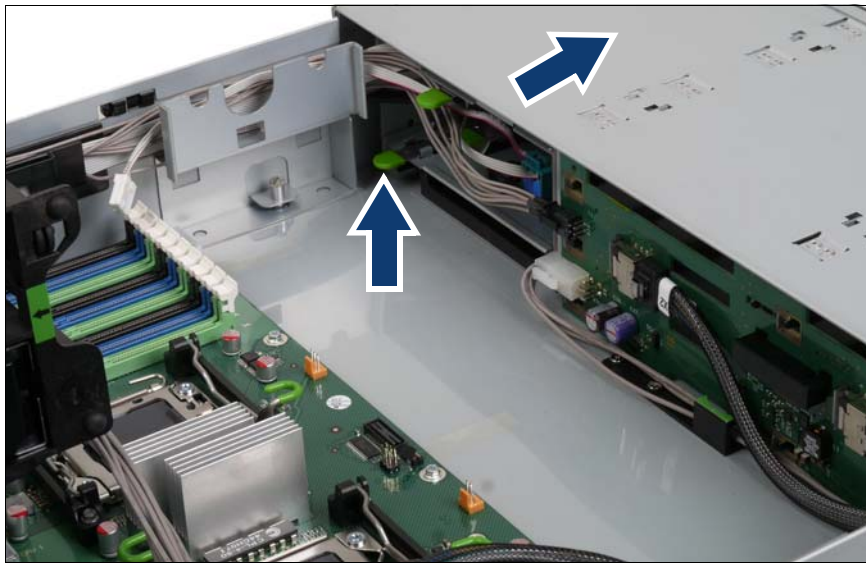

Figure 30: Unlocking the dummy module

- ▶ Unlock the dummy module.
- ▶ Push the dummy module frontward.

i Carefully push the dummy module out horizontally to avoid damaging the EMC springs.



Figure 31: Remove the dummy module

- ▶ Remove the dummy module from the bay.



CAUTION!

Store the dummy module in a safe place. If you remove the accessible drive and do not replace it with a new one, the dummy module must be reinstalled to comply with EMC regulations and to satisfy cooling requirements and fire protection measures.

- ▶ Remove the dummy module from the installation frame.



Figure 32: Installing an optical drive in the frame

- ▶ Install the optical drive in the frame. Pay attention to the plastic pins that hold the drive in the frame.
- ▶ Thread the power cable and SATA cable through the bay.



Figure 33: Connect the power and data cable.

- ▶ Connect the power cable to the optical drive (see the cabling plans in the [chapter "Appendix" on page 115](#)).
- ▶ Connect the SATA cable to the drive (see the cabling plan in the [chapter "Appendix" on page 115](#)).



Figure 34: Installing an optical drive

i Carefully insert the optical drive horizontally to avoid damaging the EMC springs.

- ▶ Push the optical drive right into the bay.



Figure 35: Connecting the SATA cable to the system board

- ▶ Connect the SATA cable to the connector SATA1 on the system board (see the cabling plans in the [chapter "Appendix" on page 115](#)).
- ▶ Replace the fan box (see [section "Installing a fan box" on page 107](#)).
- ▶ Close the server, connect it to the power outlet, and switch it on as described in the [chapter "Completion" on page 107](#).

7.3 USB tape drive/USB RDX drive

i A USB drive can only be installed in the 6x 3.5" and 8x 2.5" hard disk drive variant.

- ▶ Open the server as described in [section "Opening the server" on page 24](#).
- ▶ Remove the fan box as described in [section "Removing the fan box" on page 26](#).
- ▶ Remove the dummy covers or drives from the two upper slide-in modules (see operating manual, chapter "Hot-plug components").

7.3.1 Installing a USB drive in a 6x 3.5" variant

7.3.1.1 Installing a USB drive in a drive cage

Installing a USB tape drive in a drive cage

i The USB tape drive and USB RDX drive are installed in the USB drive module using the same method.



Figure 36: USB drive cage



Figure 37: USB tape drive



Figure 38: USB RDX drive



Figure 39: Installing a USB tape drive in a drive cage

- ▶ Insert the USB drive into the drive cage.

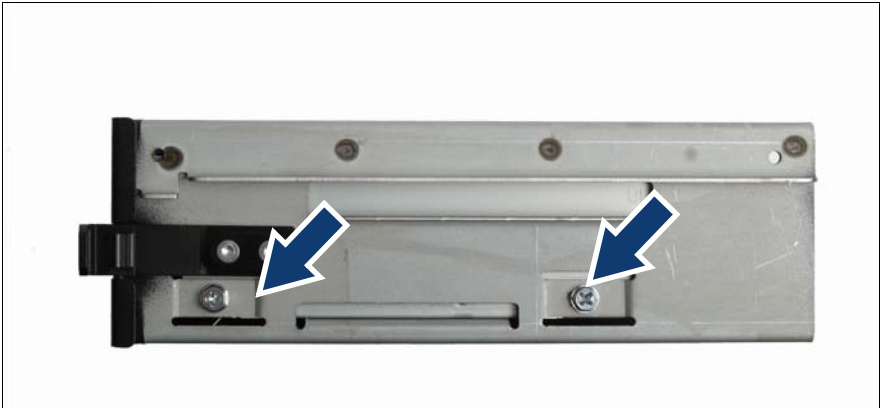

Figure 40: Securing the USB tape drive with screws

- ▶ Secure the USB tape drive with 2 screws (M3x4,5) on the left and right-hand side.

7.3.1.2 Installing a USB drive

Installing a USB tape drive

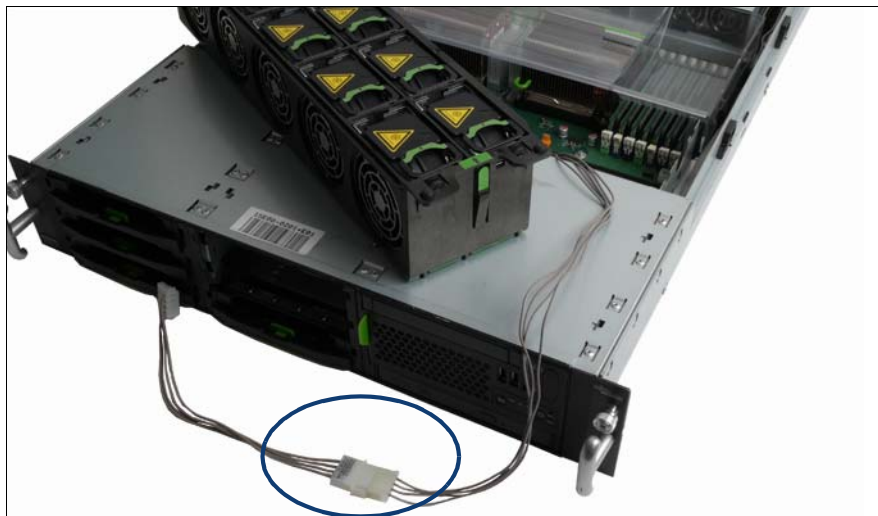

Figure 41: Connecting the power supply adapter cable

- ▶ Remove the power supply cable for the USB drive from the fan box holder.
- ▶ Connect the adapter cable.

Connecting the tape drive



Figure 42: Pushing the power supply and USB cable frontward through the bay

- ▶ Push the power supply cable frontward through the bay.
- ▶ Push the USB cable frontward through the bay. The black plug must be on the outside.

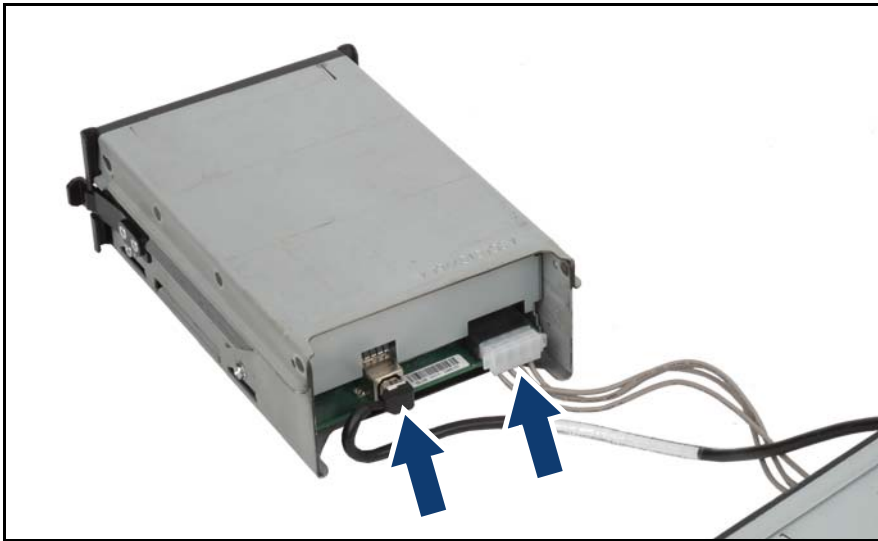

Figure 43: Connecting the cables to the USB tape drive

- ▶ Connect the two cables to the USB tape drive.



Figure 44: Pushing the USB tape drive into the server

Route the USB cable Route th

- ▶ Before pushing in the USB tape drive route the USB cable und the connector to the right side.

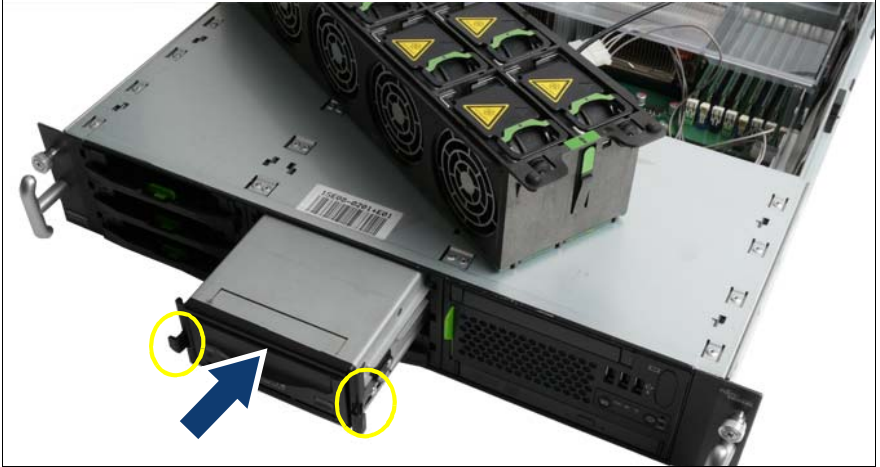

Figure 45: Installing a USB tape drive

- ▶ Push the drive in.
 - i** Make sure that the locking levers at both sides (see circles) are engaged. Press the locking levers outward.
- ▶ When pushing in the drive, pull the cables back carefully to ensure that they do not become trapped.

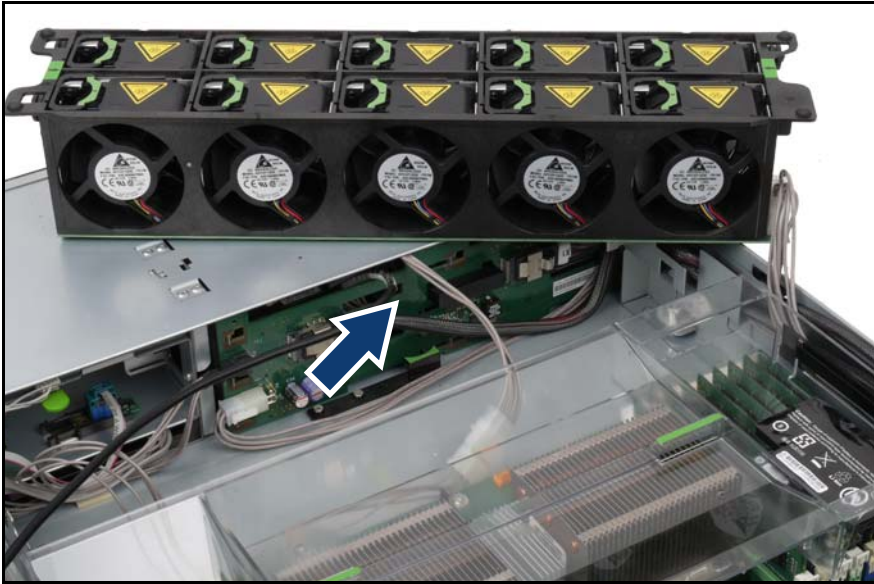

Figure 46: Routing the cable

- First route the cables to the right (see photograph) and then up, to ensure that the cables do not become trapped between the backplane and the USB drive module. Check the cable routing through the slit in the backplane.



Figure 47: Connecting the USB cable to the system board

- ▶ Connect the USB cable to the system board in USB slot 1 (see cabling plan in the [chapter "Appendix" on page 115](#)).

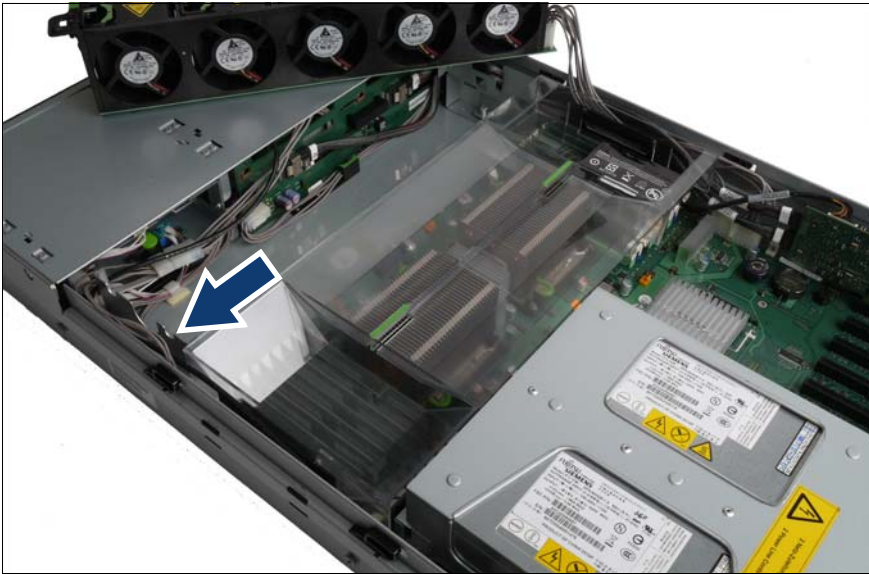

Figure 48: Routing cables in the fan box holder and air duct holder

- ▶ Route the cables in the fan box holder and air duct holder as shown in the photograph.
- ▶ Replace the fan box (see [section "Installing a fan box" on page 107](#)).
- ▶ Close the server, connect it to the power outlet, and switch it on as described in the [section "Closing the server" on page 111](#).

Installing a USB RDX drive



Figure 49: Pushing the power supply and USB cable frontward through the bay

- ▶ Push the power supply cable frontward through the bay.
- ▶ Push the USB cable frontward through the bay. The black plug must be on the outside.

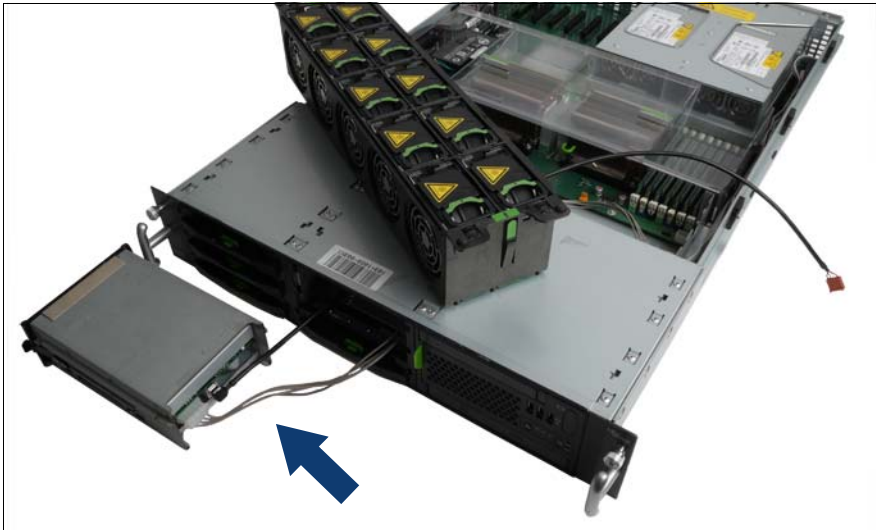

Figure 50: Connecting a USB RDX drive

- ▶ Connect the power supply cable to the RDX drive.
- ▶ Connect the USB cable to the RDX drive.
- ▶ Push the drive in.
 - i** Make sure that the locking levers at both sides (see circles in [figure 45](#)) are engaged. Press the locking levers outward.
- ▶ When pushing in the drive, pull the cables back carefully to ensure that they do not become trapped.

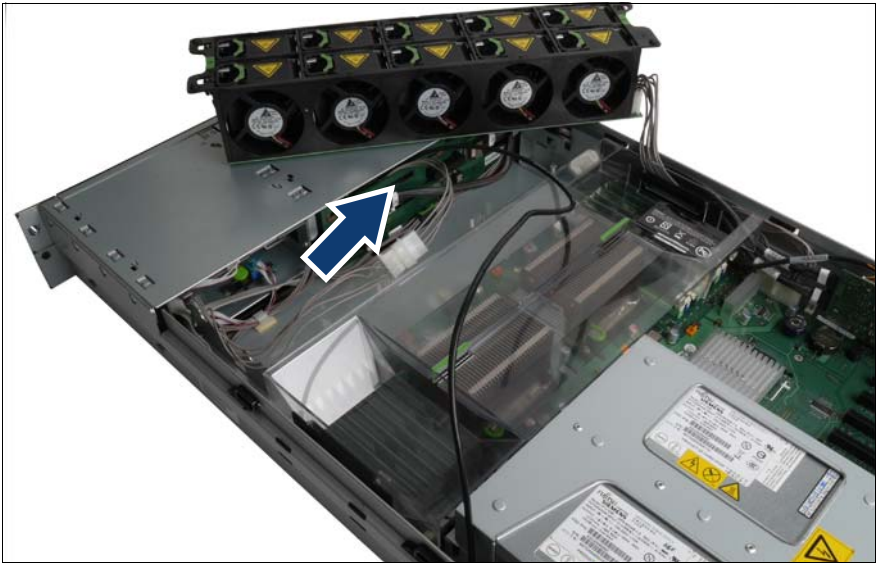

Figure 51: Installing a USB RDX drive

- ▶ First route the cables to the right (see photograph) and then up, to ensure that the cables do not become trapped between the backplane and the USB drive module. Check the cable routing through the slit in the backplane.



Figure 52: Connecting the USB cable to the system board

- ▶ Connect the USB cable to the system board in USB slot 1 (see cabling plan in the [chapter "Appendix" on page 115](#)).



Figure 53: Routing the USB cable and power supply cable through the fan box holder and air duct holder

- ▶ Route the cables in the fan box holder and air duct holder as shown in the photograph.
- ▶ Replace the fan box (see [section "Installing a fan box" on page 107](#)).
- ▶ Close the server, connect it to the power outlet, and switch it on as described in the [section "Closing the server" on page 111](#).

7.3.2 Installing a USB drive in the 8x 2.5" variant



In the 8x 2.5" variant, the DAT and RDX drive are installed using the same method, except for the cabling.

7.3.2.1 Installing a USB drive

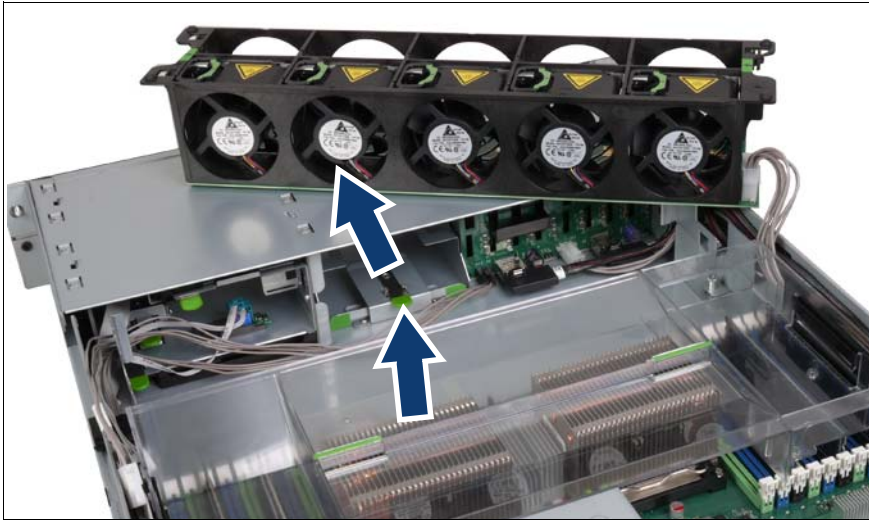

Figure 54: Removing a drive module

- ▶ Unlock the USB drive module by pushing the locking lever up.
- ▶ Push the USB drive module out frontward.

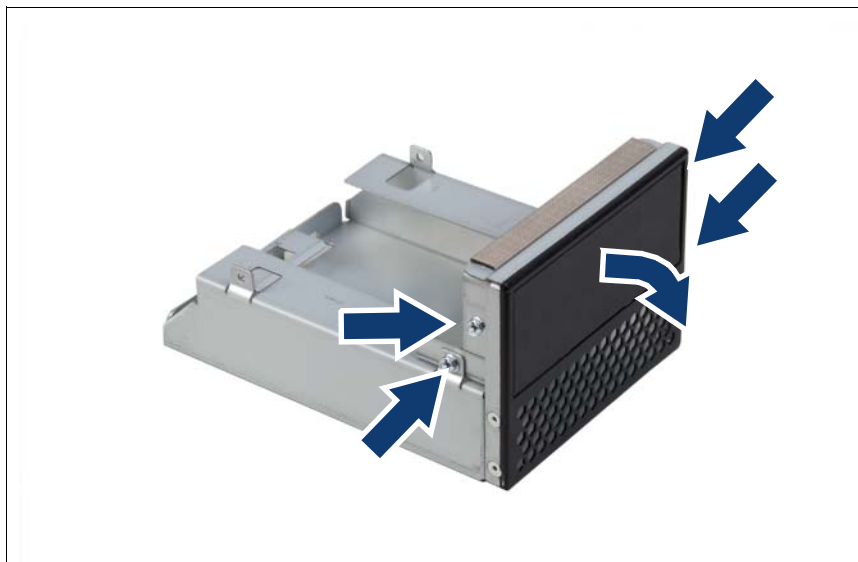

Figure 55: Preparing the drive module

- ▶ Remove the two screws on both sides.
- ▶ Remove the cover.

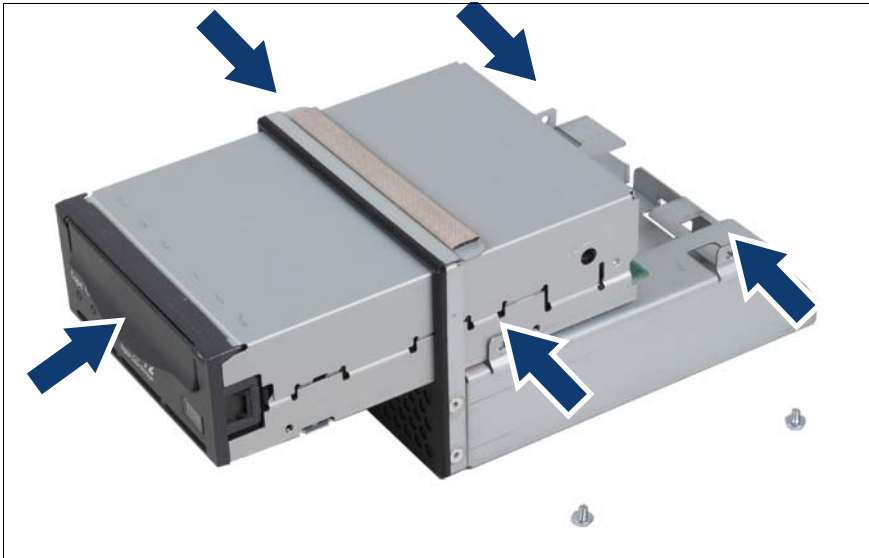

Figure 56: Inserting the USB drive into the drive module

- ▶ Insert the USB drive into the drive module.
- ▶ Secure the drive with the 4 screws (M3x4).



Figure 57: Inserting the drive module

- ▶ Insert the drive module.



CAUTION!

When you push back the USB drive module, take care that the SAS backplane do not lay in front of the drive module. In this case you must push back the backplane into the correct position before you push the drive module in completely.

7.3.2.2 Connecting a USB drive

Connecting a USB tape drive

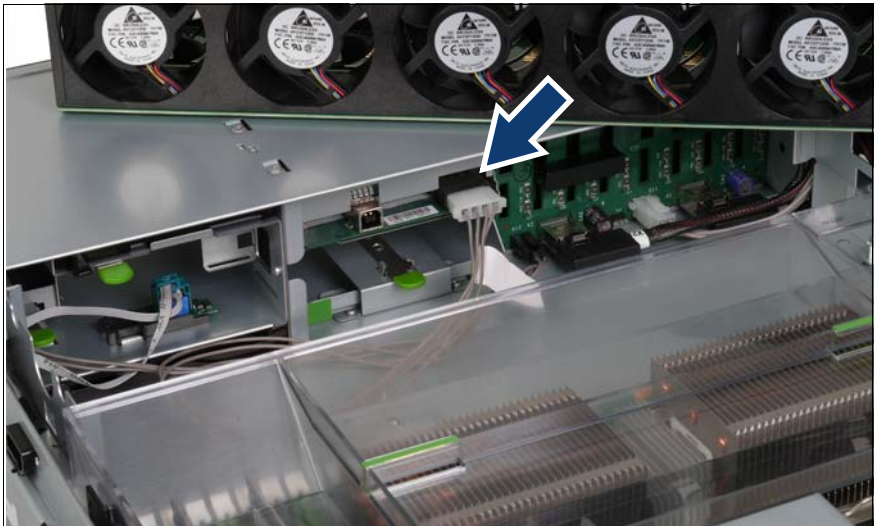

Figure 58: Connecting the power supply cable

- ▶ Connect the power supply cable to the USB drive.

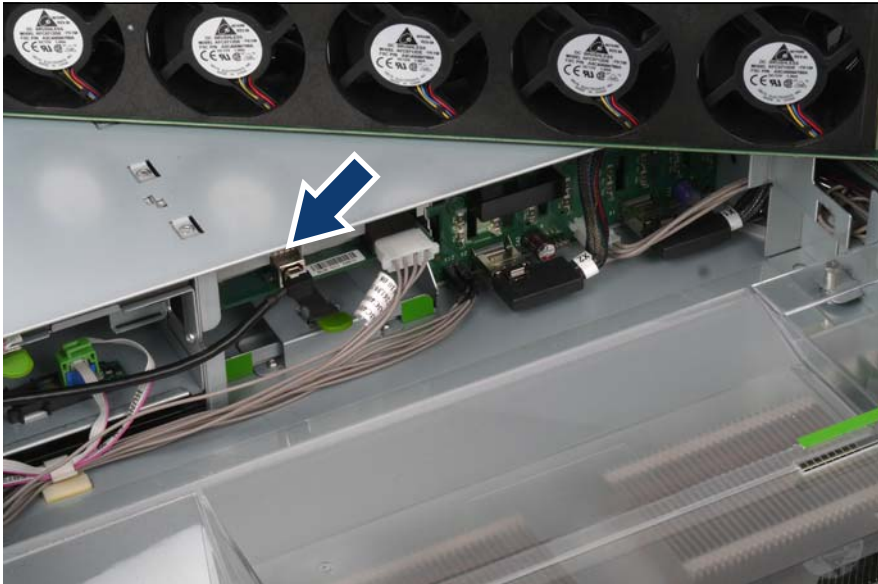

Figure 59: Connecting the USB cable

- ▶ Connect the USB cable to the USB drive.



Figure 60: Connecting the USB cable for the tape drive to the system board

- ▶ Connect the USB cable to the system board in USB slot 1 (see cabling plan in the [chapter "Appendix" on page 115](#)).



Figure 61: Routing cables in the fan box holder and air ductholder

- ▶ Route the cables in the fan box holder and air duct holder as shown in the photograph.
- ▶ Replace the fan box (see [section "Installing a fan box" on page 107](#)).
- ▶ Close the server, connect it to the power outlet, and switch it on as described in the [section "Closing the server" on page 111](#).

Connecting a USB RDX drive

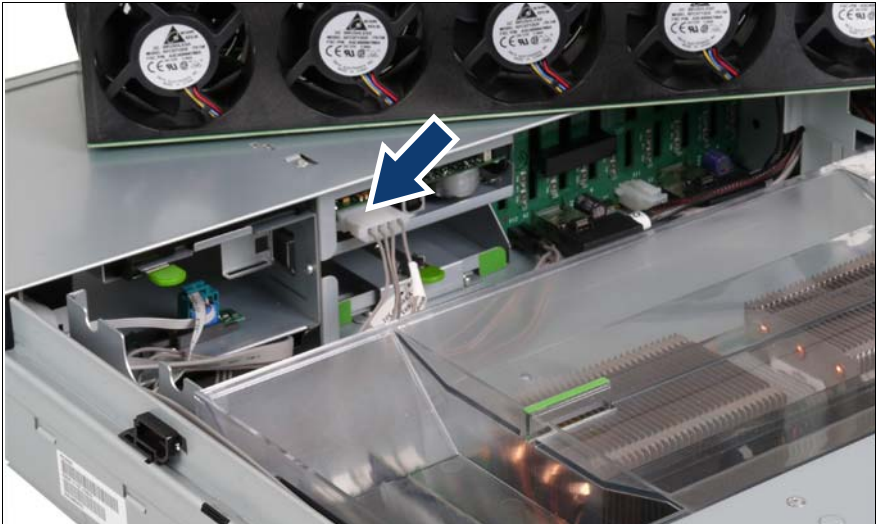

Figure 62: Connecting the power supply cable

- ▶ Connect the power supply cable to the USB drive.

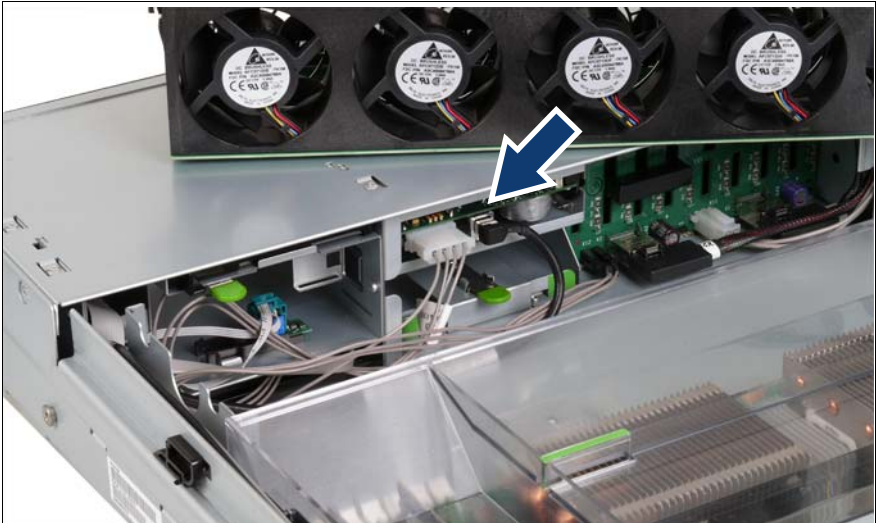

Figure 63: Connecting the USB cable

- ▶ Connect the USB cable to the USB drive.



Figure 64: Connecting the USB cable for the tape drive to the system board

- ▶ Connect the USB cable to the system board in USB slot 1 (see cabling plan in the [chapter "Appendix" on page 115](#)).

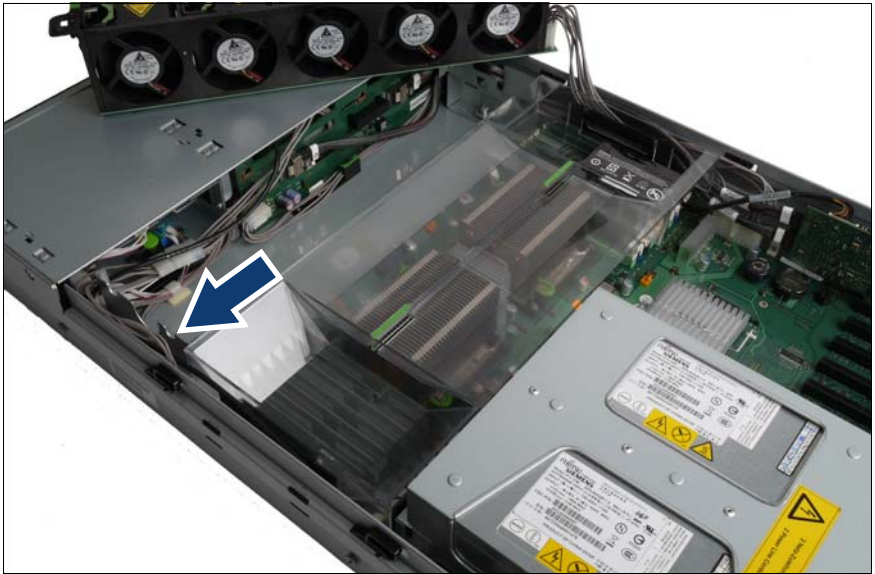

Figure 65: Routing cables in the fan box holder and air duct holder

- ▶ Route the cables in the fan box holder and air duct holder as shown in the photograph.
- ▶ Replace the fan box (see [section "Installing a fan box" on page 107](#)).
- ▶ Close the server, connect it to the power outlet, and switch it on as described in the [section "Closing the server" on page 111](#).

8 Expansion cards in the PCI slots



CAUTION!

Please note the safety instructions in [chapter "Safety instructions" on page 17](#)



The system board offers seven low profile PCI slots:

There are no hot-plug slots.

In the standard setup, slot 1 is populated with a SAS controller.

You will find an overview of the slots in the technical manual for the system board D2619.

8.1 Installing an expansion card

- ▶ Open the server as described in [chapter "Preparation" on page 23](#).



Figure 66: Removing the rear cover

- ▶ Remove the screw from the rear cover of the slot you want to equip.
- ▶ Remove the rear cover.

**CAUTION!**

Keep the rear cover of the PCI slot. If you remove the controller again and do not replace it with a new one, the rear cover must be reinstalled to comply with EMC regulations and to satisfy cooling requirements and fire protection measures.

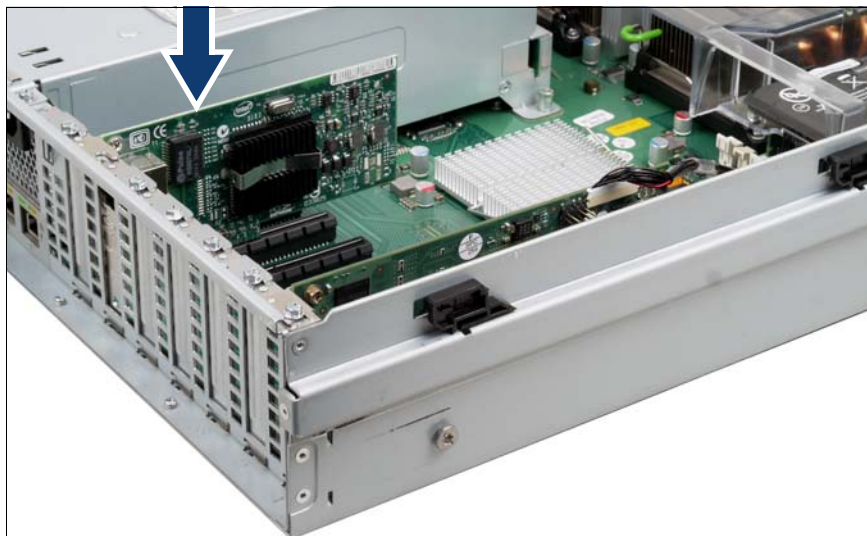

Figure 67: Installing a controller

- ▶ Install the expansion card into the PCI slot and press it carefully into the associated plug-in location on the system board.
- ▶ Secure the rear cover with the screw.
- ▶ If required, connect the cables to the system board or other components.
- ▶ Close the server, connect it to the power outlet, and switch it on as described in the [chapter "Completion" on page 107](#).

8.2 Upgrading a SAS controller

i A SAS controller is required for operating internal hard disk drives. A SAS HBA or a SAS RAID controller is available for this purpose.

- ▶ Open the server as described in [chapter "Preparation" on page 23](#).

Preparing a SAS RaidController for installation



Figure 68: SAS RAID controller with a low profile rear cover

- ▶ Secure the rear cover using the 2 screws in the square holes of the SAS controller.
- ▶ Insert the RAID key.

Installing a SAS RAID controller

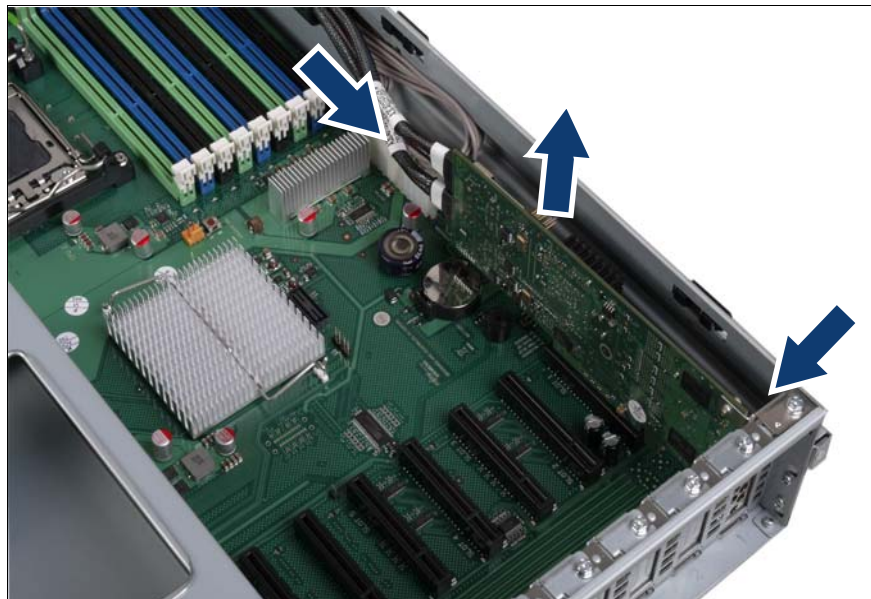

Figure 69: Removing a controller

- ▶ Remove the screw.
- ▶ Loosen the two SAS cables.
- ▶ Pull out the controller.

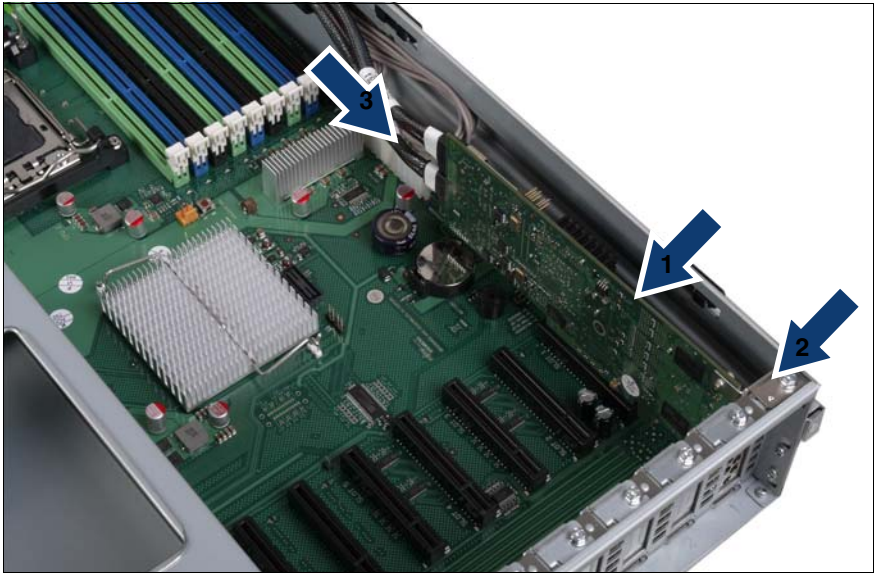

Figure 70: Installing a controller

- ▶ Insert the SAS controller into PCI slot 1 (1) and push it carefully to secure.
- ▶ Secure the rear cover (2) with a screw.
- ▶ Connect plug X1 to the upper slot and plug X2 to the lower slot of the controller (3).
- ▶ Close the server, connect it to the power outlet, and switch it on as described in the [chapter "Completion" on page 107](#).

9 Battery Backup Unit



CAUTION!

Please note the safety instructions in [chapter "Safety instructions" on page 17](#)

9.1 BBU-Modul einbauen

- ▶ Open the server as described in [section "Opening the server" on page 24](#).
- ▶ Remove the air duct as described in the [section "Removing the air duct" on page 25](#)

Preparing a BBU module

- ▶ Connect the cable from the battery to the board.

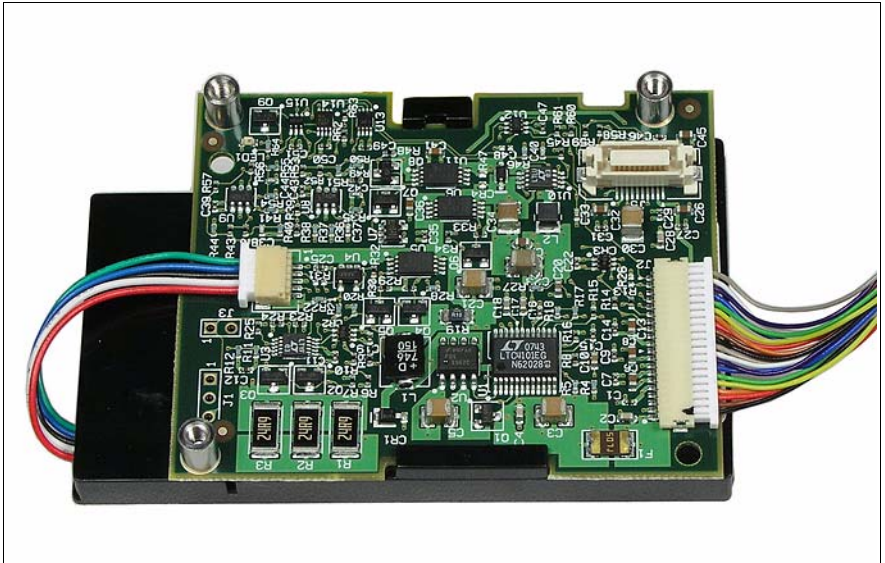

Figure 71: Connecting the cable from the battery to the board

Installing BBU 1 for SAS controllers

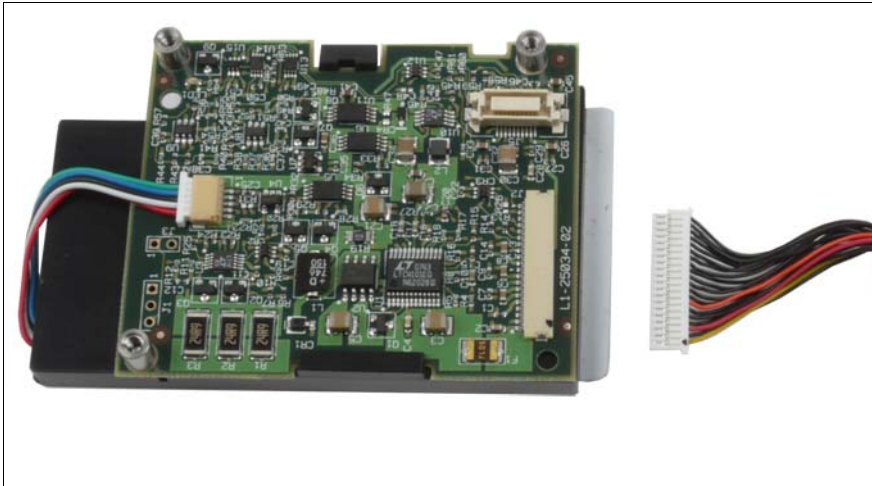

Figure 72: Connecting the BBU cable

- ▶ Connect the BBU cable. Use the short cable for the controller in slot 1.

i The side of the plug with 2 pin rows must be facing upward.



Figure 73: Screwing the BBU to the air duct

- ▶ Place the BBU on the air duct in such a way that the 3 holes are in line with the bolts on the BBU.
- ▶ Secure the BBU to the air duct using the 3 screws.



Figure 74: Inserting the air duct

- ▶ Insert the air duct.

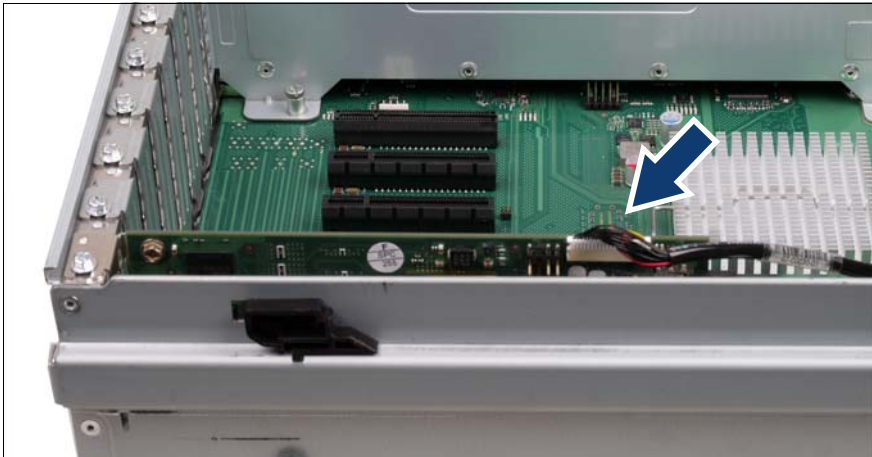

Figure 75: Connecting the BBU to a SAS controller

- ▶ Connect the connecting cable (BBU to controller) on the controller.



The side of the plug with just one pin row must be facing the board.

Installing BBU2 for slot 7

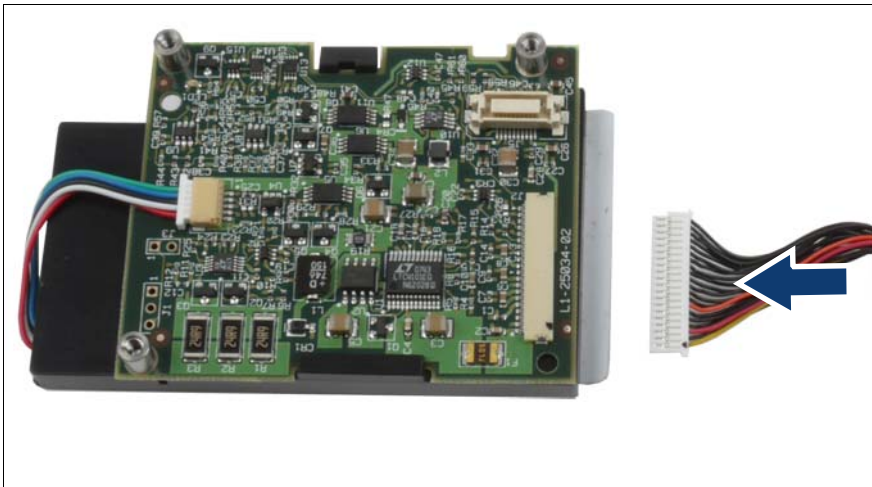

Figure 76: Connecting the battery

- ▶ Connect the BBU cable. Use the long cable for the controller in slot 7.



The side of the plug with 2 pin rows must be facing upward.

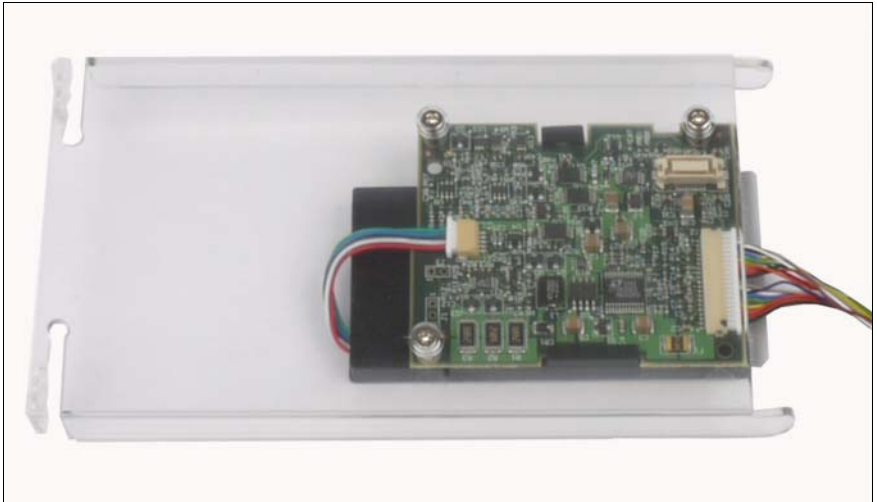

Figure 77: Securing BBU 2 to the cover

- ▶ Secure the BBU to the air duct using the 3 screws.

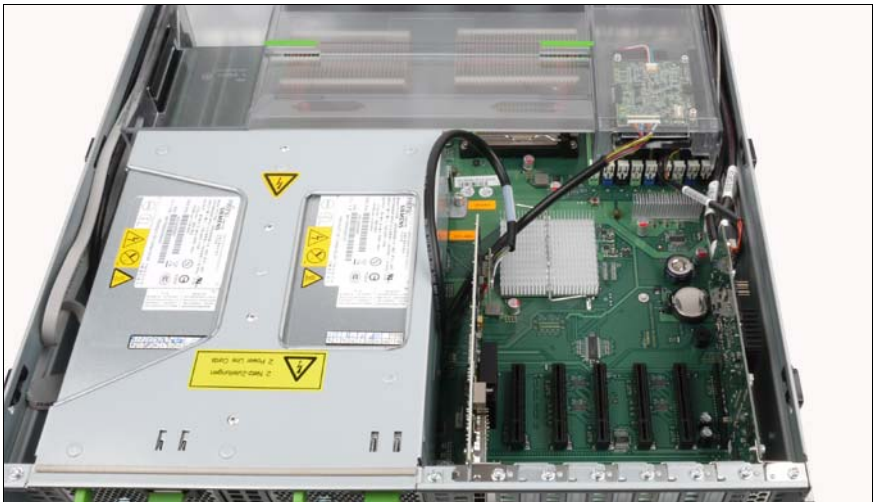

Figure 78: Connecting BBU 2 to the controller

- ▶ Insert the cover into the air duct.

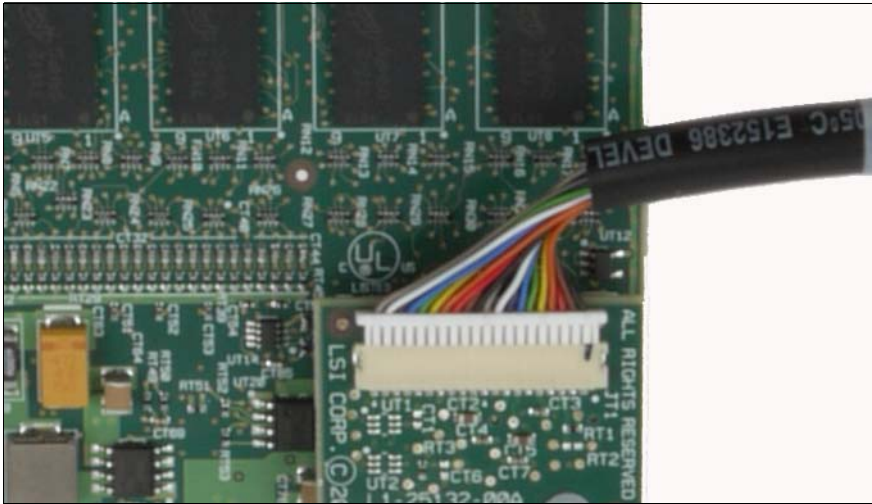

Figure 79: Connecting the cable to the controller

- ▶ Connect the connecting cable (BBU to controller) on the controller.
 - i** The side of the plug with just one pin row must be facing the board.
- ▶ Push the cable behind the controller between the power supply cage and the controller.
- ▶ Close the server, connect it to the power outlet, and switch it on as described in the [section "Closing the server" on page 111](#).

10 Front VGA port



CAUTION!

Please note the safety instructions in [chapter "Safety instructions" on page 17](#)

10.1 Installing a front VGA port

- ▶ Open the server as described in [chapter "Preparation" on page 23](#).
- ▶ Remove the air duct as described in [section "Removing the air duct" on page 25](#).



Figure 80: Removing a VGA cover

- ▶ Remove the VGA cover at the front of the server.



Figure 81: Preparing a VGA port

- ▶ Remove both screws from the plug.



Figure 82: Removing the fan box holder

- ▶ Remove the cables from the fan box holder.
- ▶ Loosen the screw and remove the fan box holder.



Figure 83: Removing the front panel frame

- ▶ Push the locking lever up.
- ▶ Pull the front panel frame inward and out.

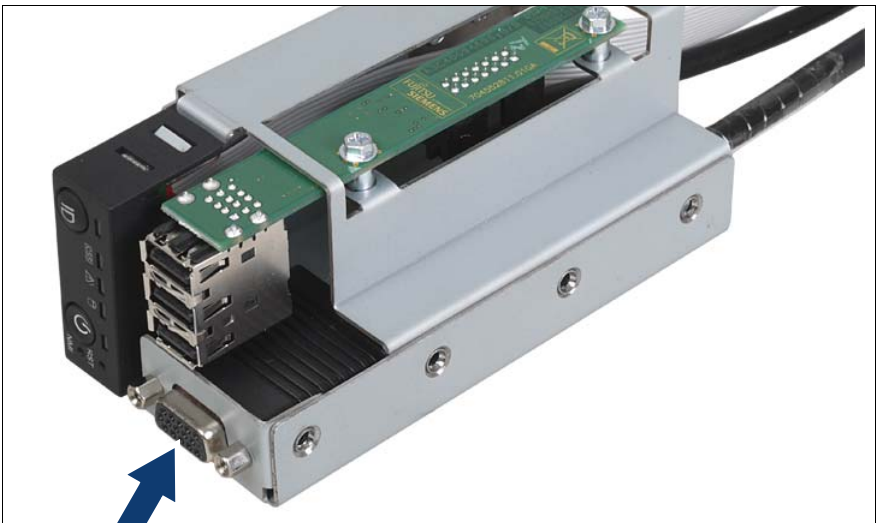

Figure 84: Installing a VGA port in the front panel frame

- ▶ Push the VGA port through the front panel frame.

- ▶ Tighten both screws.



Figure 85: Installing a front panel frame

- ▶ Replace the front panel frame.
- ▶ Push the front panel frame forward until it engages.
- ▶ Replace the fan box holder, and secure with screws.
- ▶ Route the cables in the fan box holder and air duct holder.



Figure 86: Connecting the VGA cable to the system board

- ▶ Connect the front VGA cable to the system board. See cabling plan [chapter "Appendix" on page 115](#).
- ▶ Replace the fan box (see [section "Installing a fan box" on page 107](#)).
- ▶ Close the server, connect it to the power outlet, and switch it on as described in the [chapter "Completion" on page 107](#).

11 Trusted Platform Module



CAUTION!

Please note the safety instructions in [chapter "Safety instructions" on page 17](#)

11.1 Installing a TPM-Module

- ▶ Open the server as described in [section "Opening the server" on page 24](#).
- ▶ Remove the air duct as described in [section "Removing the air duct" on page 25](#).
- ▶ Remove the power supply cage as described in [section "Removing the power supply cage" on page 27](#).

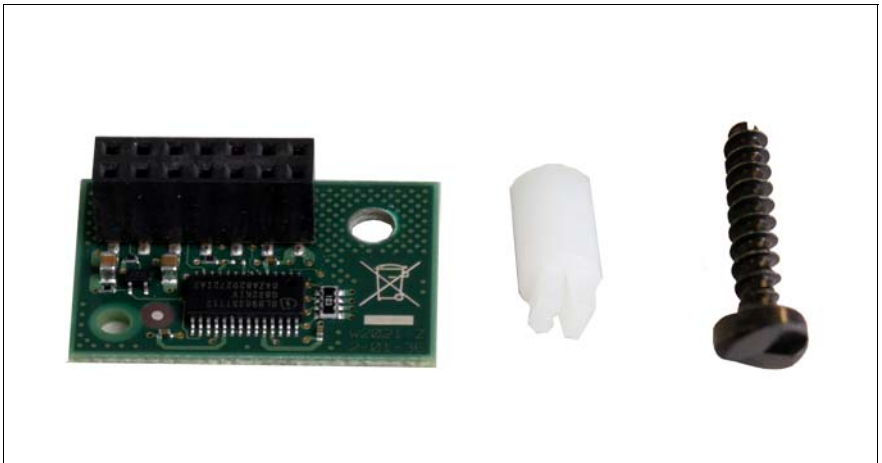

Figure 87: TPM Module, distance holder and special screw

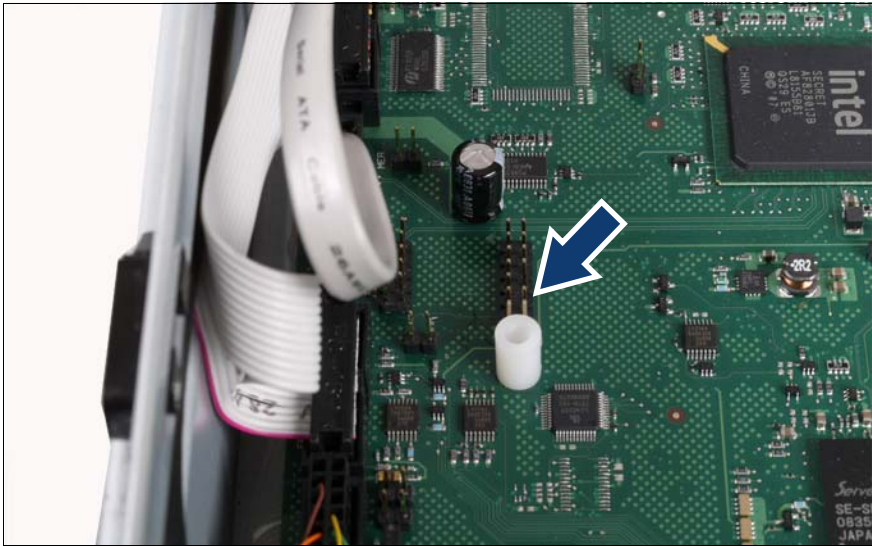

Figure 88: Installing the distance holder

- ▶ Install the distance holder.

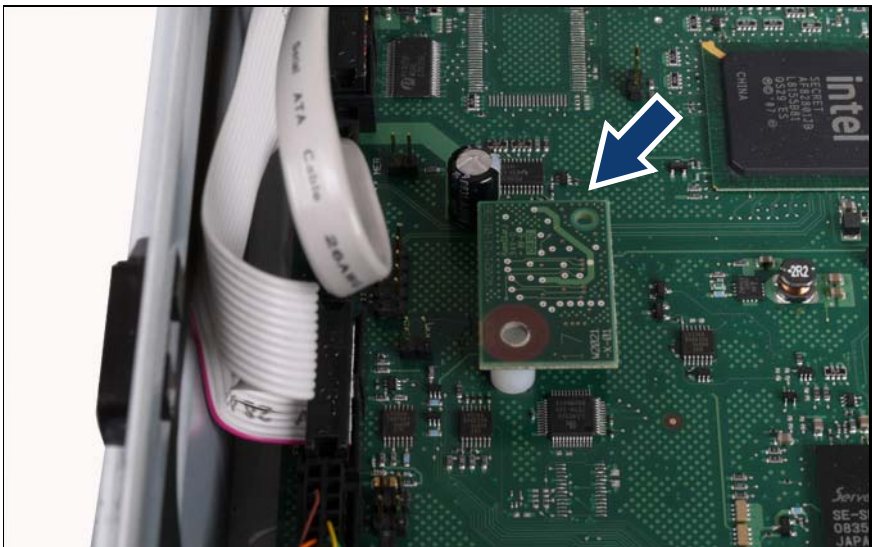

Figure 89: Installing a TPM Module

- ▶ Connect the TPM Module to the slot.

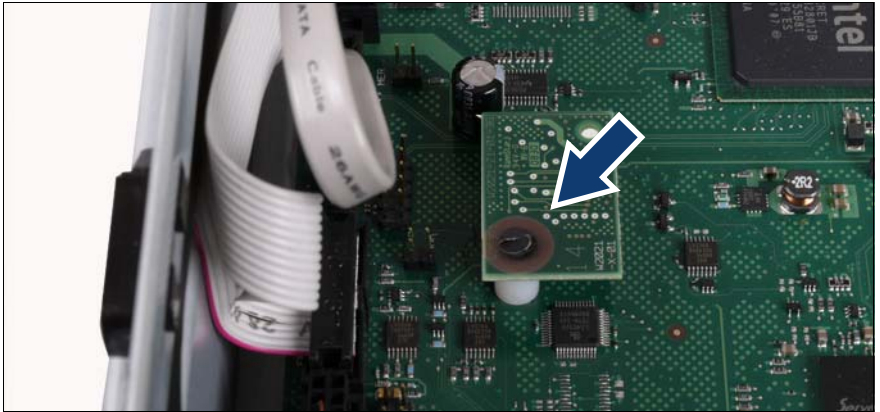

Figure 90: Securing a TPM Module

- ▶ Tighten the special screw using the special element for a bit screwdriver supplied.



Figure 91: Element for bit screwdrivers

- ▶ Reinstall the air duct (see [section "Inserting the air duct" on page 110](#)).
- ▶ Insert the power supply cage as in [section "Installing a power supply cage" on page 108](#).
- ▶ Close the server (see [section "Closing the server" on page 111](#)), insert it into the rack (see [section "Installing the server in the rack" on page 112](#)), connect it to the power outlet, and switch it on, as described.

12 USB Flash Module



CAUTION!

Please note the safety instructions in [chapter "Safety instructions" on page 17](#)

12.1 Installing USB Flash Module

- ▶ Open the server as described in [section "Opening the server" on page 24](#).
- ▶ Remove the air duct as described in [section "Removing the air duct" on page 25](#).
- ▶ Remove the power supply cage as described in [section "Removing the power supply cage" on page 27](#).



Figure 92: Inserting the USB Flash Module

- ▶ Insert the UFM into the connector on the system board.
- ▶ Press it down, until the spacer bolt snaps in.

- ▶ Insert the power supply cage as in [section "Installing a power supply cage" on page 108](#).
- ▶ Reinstall the air duct (see [section "Inserting the air duct" on page 110](#)).
- ▶ Close the server (see [section "Closing the server" on page 111](#)), insert it into the rack (see [section "Installing the server in the rack" on page 112](#)), connect it to the power outlet, and switch it on, as described.

13 Completion



CAUTION!

Please note the safety instructions in [chapter "Safety instructions" on page 17](#).

13.1 Installing a fan box

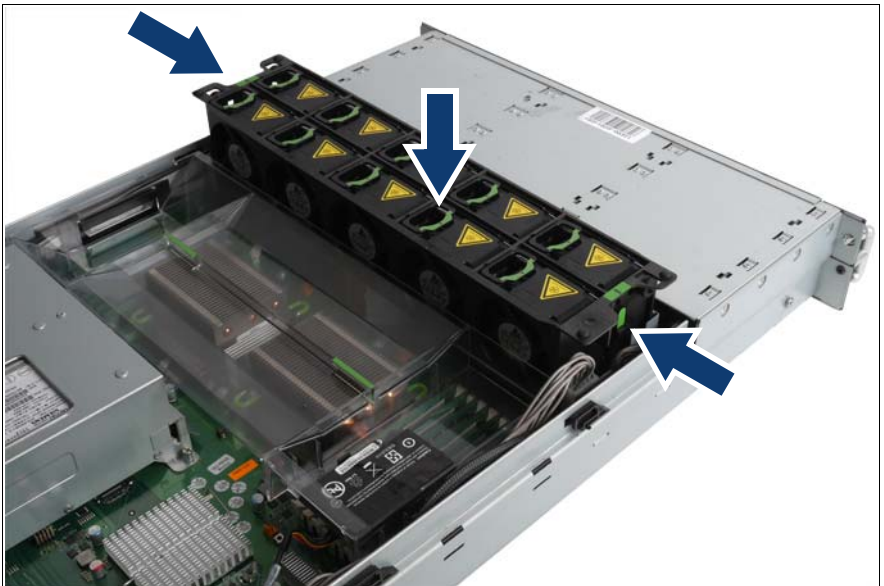

Figure 93: Installing a fan box

- ▶ Install the fan box perfectly straight.
- ▶ Push fan box down until it engages.



Make sure that all cables lie in fan box holder and air duct holder. The power cables must be under the SAS cables in the holders.

13.2 Installing a power supply cage

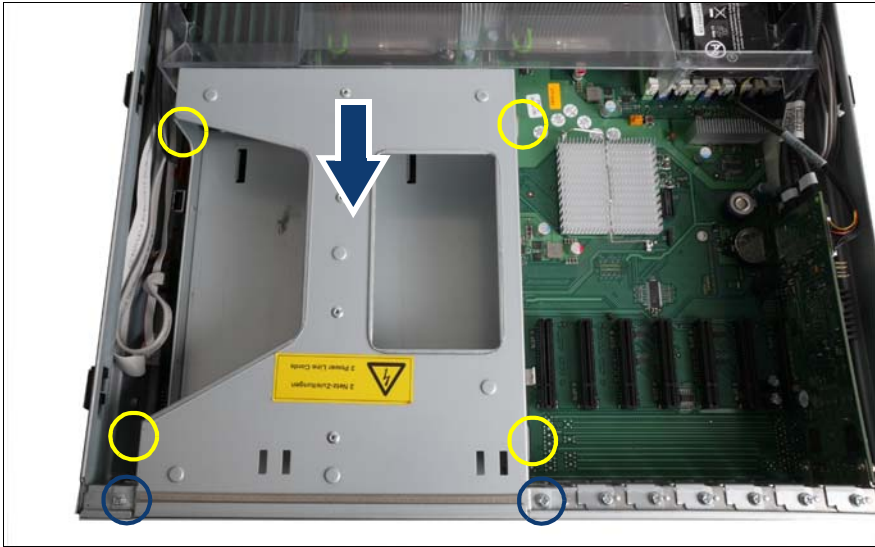

Figure 94: Installing a power supply cage

- ▶ When installing the power supply cage, keep it perfectly straight and horizontal to avoid damaging the plugs on the system board, then push to secure.
- ▶ Tighten the four captive screws (yellow circles).
- ▶ Replace the two screws (blue circles) on the top rear side and secure.



Figure 95: Removing the power supply dummy module

- ▶ Reinstall the dummy module and the power supply module(s), depending on the configuration.

13.3 Inserting the air duct

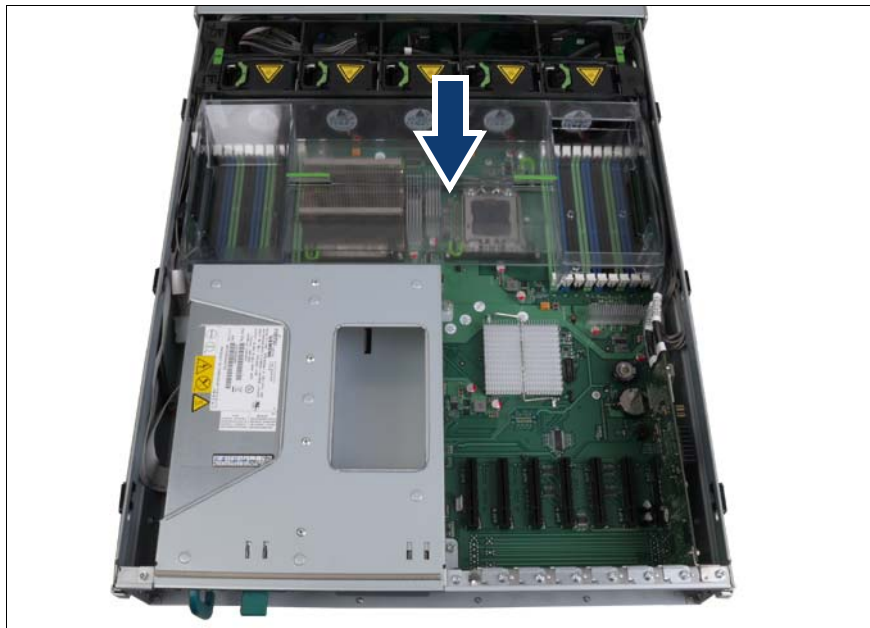

Figure 96: Inserting the air duct over the main memory and processors

- ▶ Replace the air duct over the main memory and processors.
- ▶ If a SAS/SATA RAID controller is installed and you loosened the BBU cable when removing the air duct, re-connect the BBU cable.

13.4 Closing the server

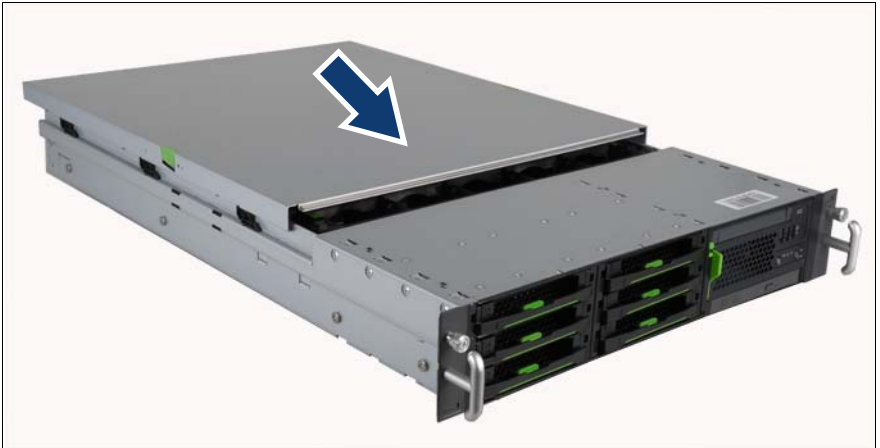

Figure 97: Closing the top cover

- ▶ Replace the top cover.
- ▶ Slide the cover forward.
- ▶ Make sure that the locks engage.

13.5 Installing the server in the rack

i If you have not removed the server from the rack cabinet, please skip this section:

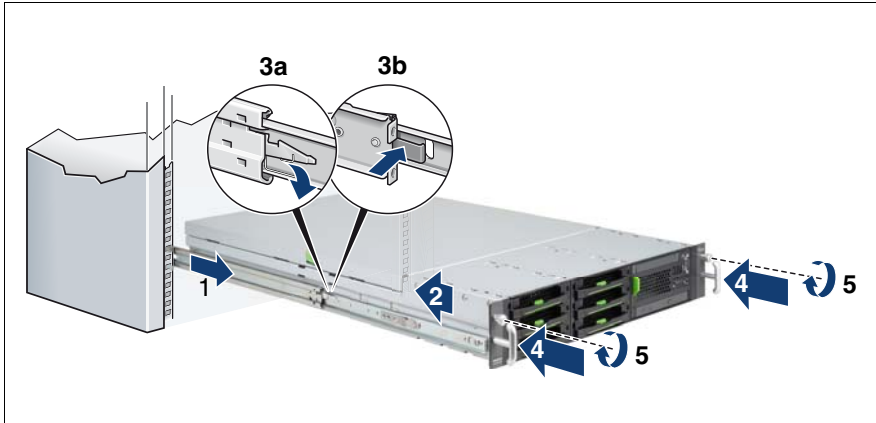

Figure 98: Installing the server in the rack cabinet



CAUTION!

Ensure that the safety lock has been inserted **before** the server is inserted.



CAUTION!

At least two people are needed to position the server in the rack.

- ▶ Extend the interior telescopic rails completely to the front (1).
 - i** They must click into place so that they can no longer be moved.
- ▶ Insert the prepared server into the protruding interior telescope rails (2) until the rails engage.
- ▶ Release the locking mechanism of both rails - see (3a) for fully extending rails and (3b) for partially extending rails.
- ▶ Push the server as far as it will go into the rack (4).
- ▶ Reconnect all the cables you disconnected beforehand and all new cables on the rear of the server.
- ▶ Secure the server in the rack using the two knurled screws (3).

- ▶ Connect all power plugs to the power outlets.
- ▶ Press the On/Off button to start up the server.

14 Appendix

14.1 Cable list

Cable # *	Part number	Code number	Name
1	T26139-Y3994-V1	A3C40097650	Front VGA
2	T26139-Y3925-V303	A3C40097792	Front panel
3	T26139-Y3928-V205	A3C40103930	SATA (750 mm)
4	T26139-Y3807-V201	A3C40097864	Front USB cable
5a	T26139-Y3986-V301	A3C40097692	Optical / USB drive power supply for barebone model S26361-K1237-A100/A200
5b	T26139-Y3986-V302	A3C40103416	Optical drive power supply for barebone model S26361-K1237-A300
5c	T26139-Y2193-V501	A3C40107771	PS adapter
6	T26139-Y3952-V301	A3C40097792	Fan board / SAS backplane power supply
7a	T26139-Y3963-V108	A3C40103413	SAS C1/X1 für 3.5"-backplane (barebone model S26361-K1237-A100)
7b	T26139-Y3963-V107	A3C40103412	SAS C2/X2 für 3.5"-backplane (barebone model S26361-K1237-A100)
7c	T26139-Y3963-V110	A3C40103415	SAS C1/X1 für 2.5"-backplane (barebone models S26361-K1237-A200 and S26361-K1237-A300)

Cable # *	Part number	Code number	Name
7d	T26139-Y3963-V109	A3C40103414	SAS C2/X2 für 2.5"-backplane (barebone models S26361-K1237-A200 and S26361-K1237-A300)
8	T26139-Y3973-V96	A3C40099017	Internal USB drives
9a	T26139-Y3987-V3	A3C40092034	BBU Slot 1
9b	T26139-Y3987-V2	A3C40090454	BBU Slot 7

The following table shows a cable overview:

*Refers to the following cabling plans.

14.2 Cabling plans

6x 3.5" HDD variant

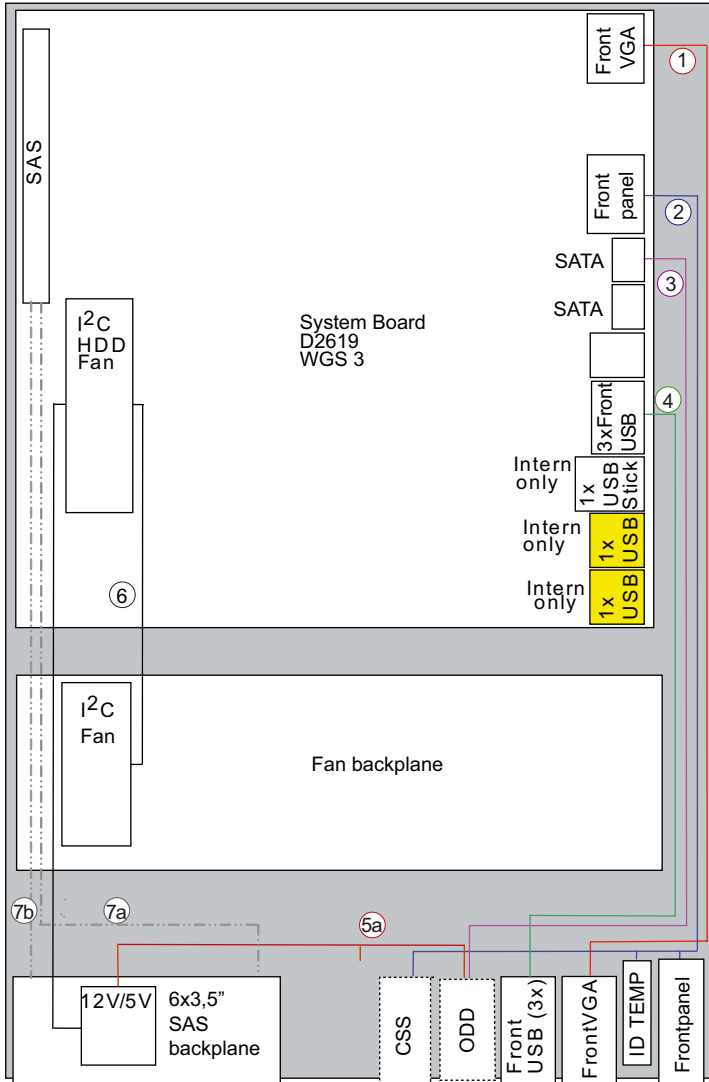

Figure 99: Cabling for PRIMERGY RX300 S5 with 3.5" hard disk drives

6x 3.5" HDD variant with USB drive

i in this configuration you can install max. 4 HDDs!

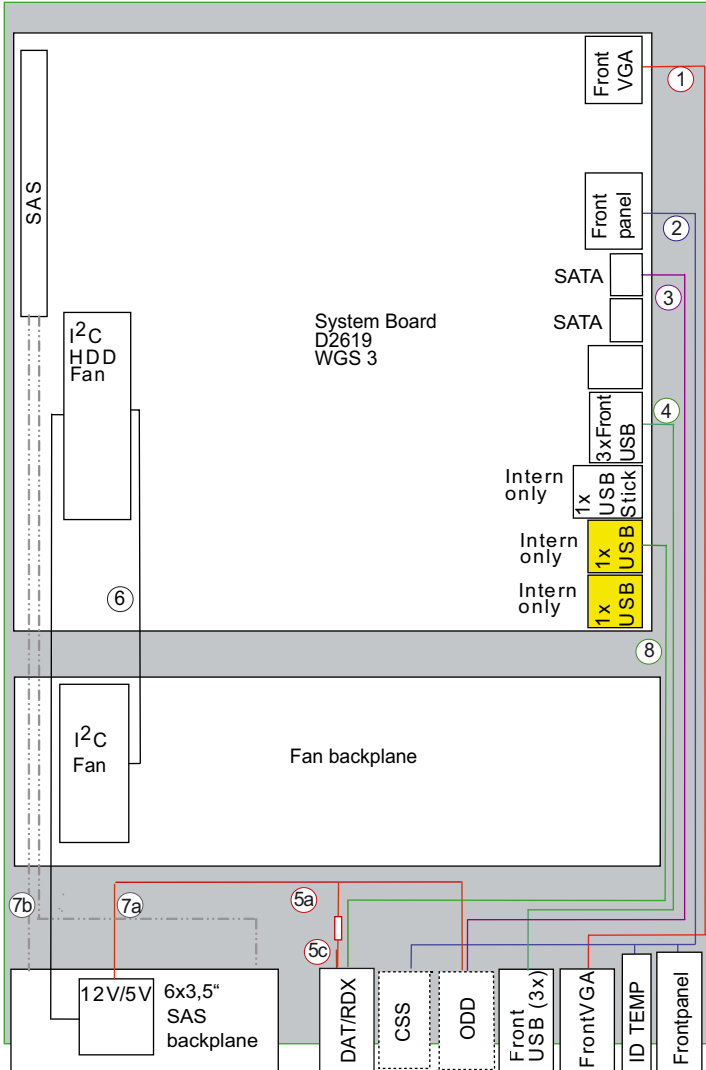

Figure 100: Cabling for PRIMERGY RX300 S5 with 3.5" hard disk drives and 1 USB drive

8x 2.5" HDD variant

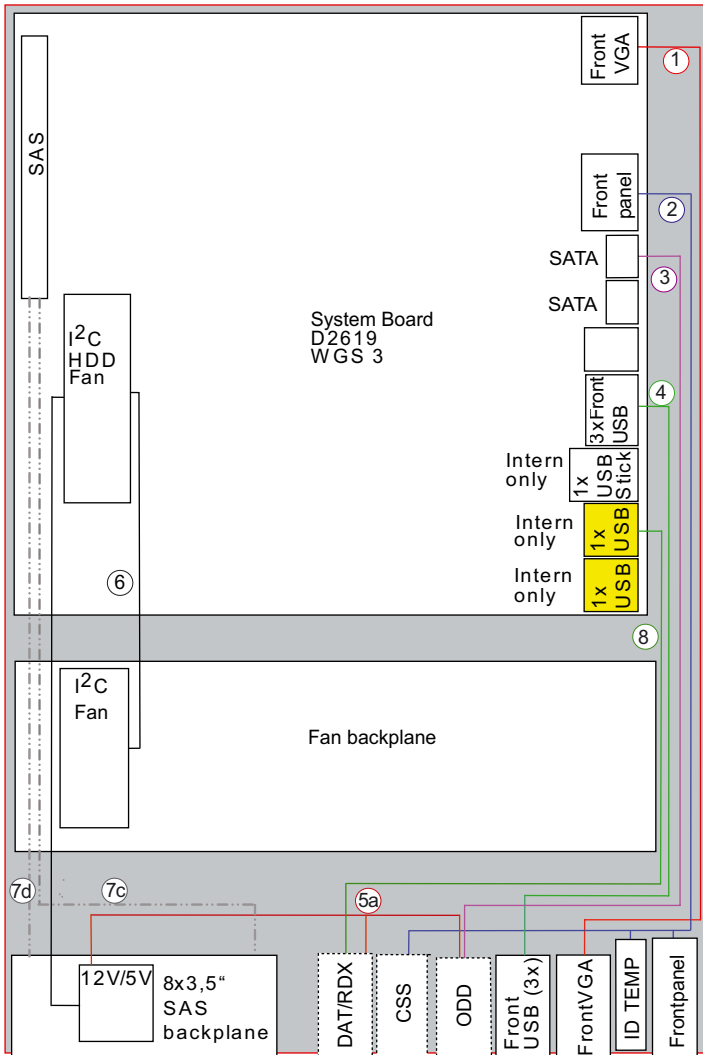

Figure 101: Cabling for PRIMERGY RX300 S5 with 8x 2.5" hard disk drives and 1 USB drive

12x 2.5" HDD variant

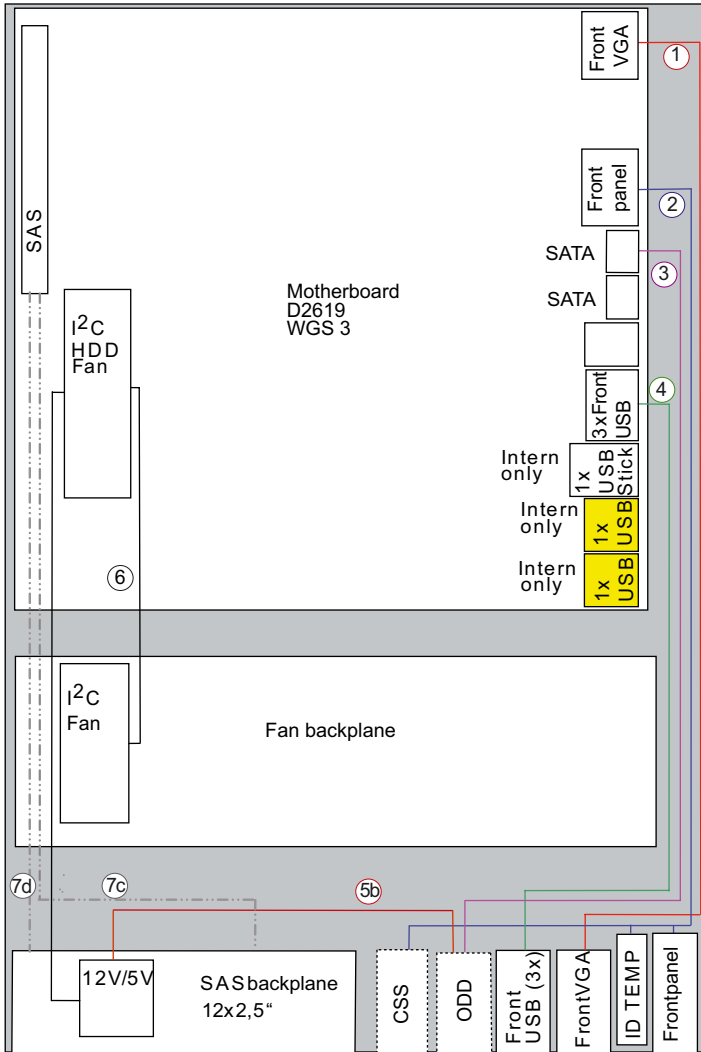

Figure 102: Cabling for PRIMERGY RX300 S5 with 12 x 2.5" hard disk drives

14.3 Configuration schema

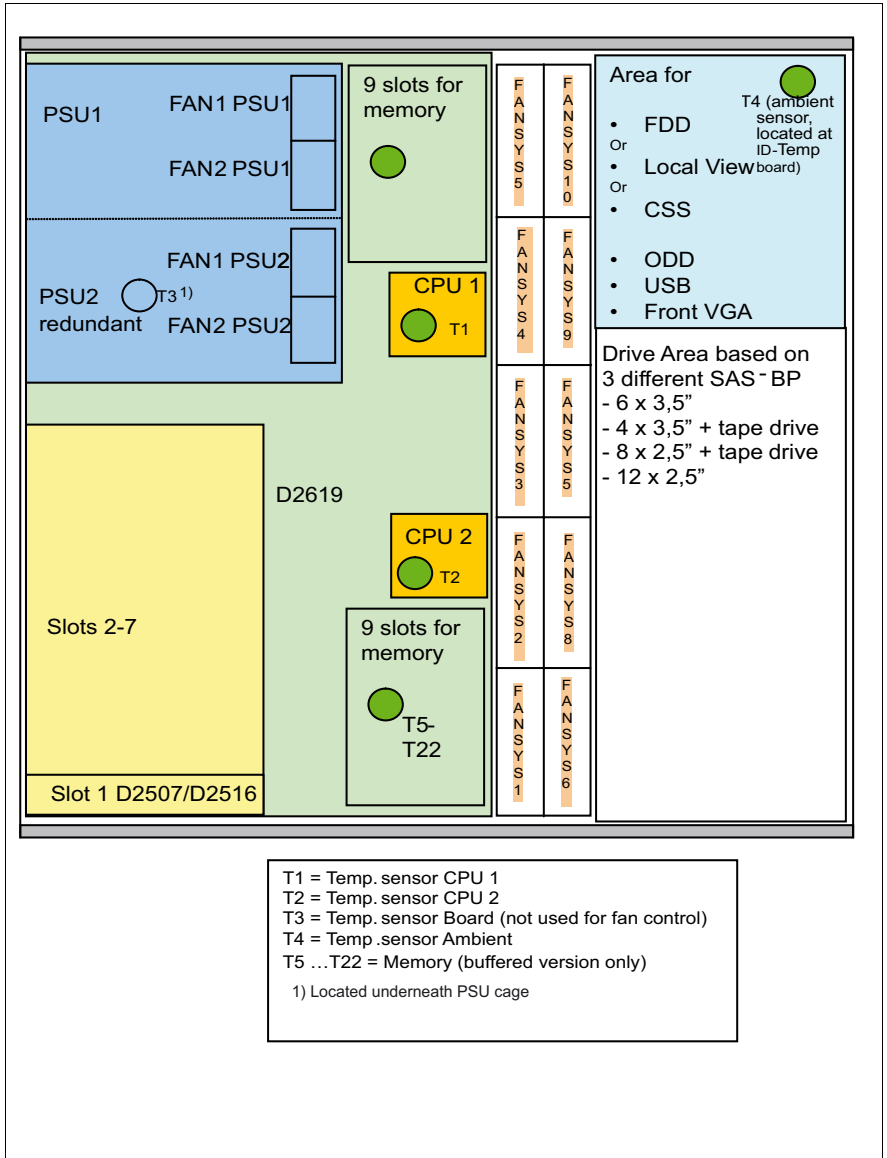

Figure 103: From the system configurator for 3.5" hard disk drives

Index

A

- accessible drives 10
- additional battery 12
- air duct 25
- Anschluss USB-Bandlaufwerk 3,5"
 - Variante 62

B

- battery backup unit 12
- battery connecting cable 92, 94
- BBU 12

C

- cable channel 96
- cable list 115
- cabling for RAID controllersf 87
- connecting cable battery 92, 94
- connecting optical drive 54
- connecting USB RDX drive, 2.5"
 - variant 79
- connecting USB RDX drive, 3.5"
 - variant 68
- connecting USB tape drive, 2.5"
 - variant 75
- controller 12, 83, 85
- CSS dummy module 48

D

- data manipulation 7
- dual operation 33, 42
- dummy module 48
- dummy module optical drive
 - unlocking 52
- dummy module unlocking 48

E

- ESD (devices sensitive to electrostatic discharge) 21
- expansion cards 83
- expansions 9

F

- fan box 26
- fan box holder 96
- fan box lock 26
- FD dummy module 48
- fitting rules 30
- front panel frame
 - unlocking 97
- front VGA port 95

H

- hard disk drive configurations 12
- heat sink 40, 45

I

- IME 10
- Independent Channel Mode 9
- information, additional 9
- Integrated Mirroring Enhanced 10

L

- laser information 21
- light emitting diode (LED) 21
- lithium battery 20
- low profile PCI slots 83

M

- magnetic tape drive 11
- main memory 9
- meaning of the symbols 13
- MegaRAID 10
- Mirrored Channel Mode 9
- multi-processor operating system 33, 42

N

- notational conventions 13

O

- optical drive 47
- optical drive connecting 54
- optical drive dummy module

Index

unlocking [52](#)

P

partial extension [23](#)

PCI slot

low profile [83](#)

power supply cage [28](#)

power supply dummy module [27](#)

power supply module [27](#)

processor [9](#), [33](#)

processor coding [37](#), [38](#)

processor cover [35](#)

processor marking [37](#), [38](#)

processor socket cover [36](#)

R

rack [23](#)

RAID controller cabling [87](#)

RAID key [85](#)

RDX drive [11](#)

rear cover [83](#)

S

SAS cable [87](#)

SAS IME controller [10](#)

SAS MegaRAID controller [10](#)

SAS/SATA RAID controller [10](#)

security function [7](#)

ServerView Local Service

Display [11](#), [47](#)

ServerView Local Service Panel [11](#),
[47](#)

Spare Channel Mode [9](#)

special bit for TPM [103](#)

special screw for TPM [101](#)

spring clip [34](#)

T

target group [7](#)

telescopic rails [23](#)

thermal paste [40](#), [42](#), [44](#), [46](#)

TPM [13](#)

TPM Module [101](#)

TPM special bit [103](#)

Trusted Platform Module [13](#), [101](#)

U

update [9](#)

USB DAT drive [57](#)

USB RDX drive [57](#)

USB-Flash-Module [105](#)