



IBM System x3550 M3  
Type 4254 and 7944

Installation and User's Guide







IBM System x3550 M3  
Type 4254 and 7944  
Installation and User's Guide

**Note**

Before using this information and the product it supports, read the general information in “Getting help and technical assistance,” on page 133, “Notices” on page 137, the *Warranty Information* document, and the *Safety Information* and *Environmental Notices and User Guide* documents on the IBM Documentation CD.

**Twelfth Edition (June 2014)**

**© Copyright IBM Corporation 2014.**

US Government Users Restricted Rights – Use, duplication or disclosure restricted by GSA ADP Schedule Contract with IBM Corp.

# Contents

<b>Safety</b> . . . . .	<b>v</b>
Safety statements . . . . .	vii

## **Chapter 1. The IBM System x3550 M3 server** . . . . . **1**

The IBM Documentation CD . . . . .	3
Hardware and software requirements . . . . .	3
Using the Documentation Browser . . . . .	4
Related documentation . . . . .	5
Notices and statements in this document . . . . .	6
Features and specifications. . . . .	6
What your server offers . . . . .	10
Reliability, availability, and serviceability . . . . .	14
IBM Systems Director . . . . .	15
The UpdateXpress System Pack Installer . . . . .	16
Server controls, LEDs, and power . . . . .	16
Front view. . . . .	16
Operator information panel . . . . .	17
Light path diagnostics panel. . . . .	18
Light path diagnostics LEDs. . . . .	20
Rear view . . . . .	26
Power-supply LEDs . . . . .	29
System pulse LEDs . . . . .	32
Server power features . . . . .	33
Turning on the server . . . . .	33
Turning off the server . . . . .	33

## **Chapter 2. Installing optional devices** . . . . . **35**

Instructions for IBM Business Partners . . . . .	35
How to send DSA data to IBM . . . . .	35
Server components . . . . .	36
System-board internal connectors . . . . .	37
System-board external connectors . . . . .	37
System-board switches and jumpers . . . . .	38
System-board LEDs. . . . .	41
System-board optional device connectors . . . . .	42
Installation guidelines . . . . .	43
System reliability guidelines . . . . .	45
Working inside the server with the power on . . . . .	45
Handling static-sensitive devices . . . . .	46
Internal cable routing and connectors. . . . .	46
Removing the cover . . . . .	51
Removing the DIMM air baffle . . . . .	52
Removing the microprocessor 2 air baffle . . . . .	53
Installing a memory module. . . . .	54
DIMM installation sequence. . . . .	57
Memory mirroring . . . . .	58
Online-spare memory . . . . .	60
Installing a DIMM . . . . .	60
Installing drives . . . . .	62
Installing a hot-swap hard disk drive. . . . .	62
IDs for hot-swap hard disk drives . . . . .	63
Installing a simple-swap hard disk drive . . . . .	64
IDs for simple-swap hard disk drives. . . . .	65
Installing an optional DVD drive . . . . .	66

Replacing a PCI riser-card assembly . . . . .	68
Installing an adapter . . . . .	70
Replacing a PCI Express assembly with a PCI-X assembly . . . . .	73
Replacing a PCI-X assembly with a PCI Express assembly . . . . .	74
Installing a ServeRAID SAS/SATA controller on the SAS/SATA RAID riser card . . . . .	75
Installing an optional ServeRAID adapter advanced feature key . . . . .	79
Installing a hot-swap fan assembly . . . . .	80
Installing a hot-swap ac power supply . . . . .	82
Installing a USB embedded hypervisor flash device . . . . .	85
Installing the virtual media key. . . . .	86
Installing the optional two-port Ethernet adapter . . . . .	87
Installing a RAID adapter battery remotely in the server . . . . .	90
Installing the DVD enablement kit. . . . .	95
Installing a SAS/SATA 4 Pac HDD option . . . . .	97
Installing a second microprocessor and heat sink . . . . .	100
Thermal grease . . . . .	105
Completing the installation. . . . .	106
Installing the microprocessor 2 air baffle . . . . .	106
Installing the DIMM air baffle . . . . .	107
Installing the cover . . . . .	108
Connecting the cables . . . . .	109
Updating the server configuration . . . . .	110

## **Chapter 3. Configuring the server.** . . . . **111**

Using the Setup utility . . . . .	112
Starting the Setup utility. . . . .	113
Setup utility menu choices . . . . .	113
Passwords . . . . .	116
Power-on password . . . . .	117
Administrator password. . . . .	119
Using the Boot Manager program . . . . .	119
Starting the backup server firmware. . . . .	119
Using the ServerGuide Setup and Installation CD . . . . .	120
ServerGuide features . . . . .	120
Setup and configuration overview . . . . .	121
Typical operating-system installation . . . . .	121
Installing your operating system without using ServerGuide. . . . .	122
Using the integrated management module. . . . .	122
Using the remote presence capability and blue-screen capture . . . . .	123
Enabling the remote presence feature . . . . .	124
Obtaining the IP address for the IMM . . . . .	124
Logging on to the Web interface . . . . .	125
Using the embedded hypervisor . . . . .	125
Recovering the flash device image . . . . .	126
Enabling the Broadcom Gigabit Ethernet Utility program . . . . .	126
Configuring the Gigabit Ethernet controller . . . . .	127
Using the LSI Configuration Utility program . . . . .	127

Starting the LSI Configuration Utility program	128
Formatting a hard disk drive	129
Creating a RAID array of hard disk drives	129
IBM Advanced Settings Utility program	130
Updating IBM Systems Director	130
Installing a newer version	130
Installing updates with your management server is connected to the Internet	131
Installing updates with your management server is not connected to the Internet	131
The Update <i>Xpress</i> System Pack Installer	132

**Appendix. Getting help and technical assistance. . . . . 133**

Before you call	133
Using the documentation	134
Getting help and information from the World Wide Web	134
How to send DSA data to IBM	134
Creating a personalized support web page	135
Software service and support	135
Hardware service and support	135
IBM Taiwan product service	135

**Notices . . . . . 137**

Trademarks	138
Important notes	138

Particulate contamination	139
Documentation format	140
Telecommunication regulatory statement	140
Electronic emission notices	141
Federal Communications Commission (FCC) statement.	141
Industry Canada Class A emission compliance statement.	141
Avis de conformité à la réglementation d'Industrie Canada	141
Australia and New Zealand Class A statement	141
European Union EMC Directive conformance statement.	142
Germany Class A statement	142
Japan VCCI Class A statement.	143
Japan Electronics and Information Technology Industries Association (JEITA) statement	144
Korea Communications Commission (KCC) statement.	144
Russia Electromagnetic Interference (EMI) Class A statement	144
People's Republic of China Class A electronic emission statement	144
Taiwan Class A compliance statement	145

**Index . . . . . 147**

---

## Safety

Before installing this product, read the Safety Information.

قبل تركيب هذا المنتج، يجب قراءة الملاحظات الأمنية

Antes de instalar este produto, leia as Informações de Segurança.

在安装本产品之前，请仔细阅读 **Safety Information**  
(安全信息)。

安裝本產品之前，請先閱讀「安全資訊」。

Prije instalacije ovog produkta obavezno pročitajte Sigurnosne Upute.

Před instalací tohoto produktu si přečtěte příručku bezpečnostních instrukcí.

Læs sikkerhedsforskrifterne, før du installerer dette produkt.

Lees voordat u dit product installeert eerst de veiligheidsvoorschriften.

Ennen kuin asennat tämän tuotteen, lue turvaohjeet kohdasta Safety Information.

Avant d'installer ce produit, lisez les consignes de sécurité.

Vor der Installation dieses Produkts die Sicherheitshinweise lesen.

Πριν εγκαταστήσετε το προϊόν αυτό, διαβάστε τις πληροφορίες ασφάλειας  
(safety information).

לפני שתתקינו מוצר זה, קראו את הוראות הבטיחות.

A termék telepítése előtt olvassa el a Biztonsági előírásokat!

Prima di installare questo prodotto, leggere le Informazioni sulla Sicurezza.

製品の設置の前に、安全情報をお読みください。

본 제품을 설치하기 전에 안전 정보를 읽으십시오.

Пред да се инсталира овој продукт, прочитајте информацијата за безбедност.

بىلىق  
تەخنىكا  
بىلىق  
بىلىق  
بىلىق  
بىلىق  
بىلىق  
بىلىق  
بىلىق  
بىلىق

Les sikkerhetsinformasjonen (Safety Information) før du installerer dette produktet.

Przed zainstalowaniem tego produktu, należy zapoznać się z książką "Informacje dotyczące bezpieczeństwa" (Safety Information).

Antes de instalar este produto, leia as Informações sobre Segurança.

Перед установкой продукта прочтите инструкции по технике безопасности.

Pred inštaláciou tohto zariadenia si pečítajte Bezpečnostné predpisy.

Pred namestitvijo tega proizvoda preberite Varnostne informacije.

Antes de instalar este producto, lea la información de seguridad.

Läs säkerhetsinformationen innan du installerar den här produkten.

ཐོན་ཁུངས་འདི་བདེ་སྤྱོད་མ་བྱས་གོང་། རྒྱ་ལྷོ་ཡིད་གཟབ་  
བྱ་འདྲ་མིན་ཡོད་པའི་འོད་སྤེར་བལྟ་དགོས།

Bu ürünü kurmadan önce güvenlik bilgilerini okuyun.

مەزكۇر مەھسۇلاتنى ئورنىتىشتىن بۇرۇن بىخەتەرلىك ئۇچۇرلىرىنى ئوقۇپ چىقىڭ.

Youq mwngz yungh canjbinj neix gaxgonq, itdingh aeu doeg aen  
canjbinj soengq cungj vahgangj ancien siusik.

---

## Safety statements

These statements provide the caution and danger information that is used in this documentation.

### Important:

Each caution and danger statement in this documentation is labeled with a number. This number is used to cross reference an English-language caution or danger statement with translated versions of the caution or danger statement in the *Safety Information* document.

For example, if a caution statement is labeled Statement 1, translations for that caution statement are in the *Safety Information* document under Statement 1.

Be sure to read all caution and danger statements in this documentation before you perform the procedures. Read any additional safety information that comes with your system or optional device before you install the device.

### Statement 1



#### DANGER

Electrical current from power, telephone, and communication cables is hazardous.

**To avoid a shock hazard:**

- Do not connect or disconnect any cables or perform installation, maintenance, or reconfiguration of this product during an electrical storm.
- Connect all power cords to a properly wired and grounded electrical outlet.
- Connect to properly wired outlets any equipment that will be attached to this product.
- When possible, use one hand only to connect or disconnect signal cables.
- Never turn on any equipment when there is evidence of fire, water, or structural damage.
- Disconnect the attached power cords, telecommunications systems, networks, and modems before you open the device covers, unless instructed otherwise in the installation and configuration procedures.
- Connect and disconnect cables as described in the following table when installing, moving, or opening covers on this product or attached devices.

**To Connect:**

1. Turn everything OFF.
2. First, attach all cables to devices.
3. Attach signal cables to connectors.
4. Attach power cords to outlet.
5. Turn device ON.

**To Disconnect:**

1. Turn everything OFF.
2. First, remove power cords from outlet.
3. Remove signal cables from connectors.
4. Remove all cables from devices.

## Statement 2



### CAUTION:

When replacing the lithium battery, use only IBM® Part Number 33F8354 or an equivalent type battery recommended by the manufacturer. If your system has a module containing a lithium battery, replace it only with the same module type made by the same manufacturer. The battery contains lithium and can explode if not properly used, handled, or disposed of.

*Do not:*

- Throw or immerse into water
- Heat to more than 100°C (212°F)
- Repair or disassemble

Dispose of the battery as required by local ordinances or regulations.

## Statement 3



### CAUTION:

When laser products (such as CD-ROMs, DVD drives, fiber optic devices, or transmitters) are installed, note the following:

- Do not remove the covers. Removing the covers of the laser product could result in exposure to hazardous laser radiation. There are no serviceable parts inside the device.
- Use of controls or adjustments or performance of procedures other than those specified herein might result in hazardous radiation exposure.



## DANGER

Some laser products contain an embedded Class 3A or Class 3B laser diode. Note the following.

Laser radiation when open. Do not stare into the beam, do not view directly with optical instruments, and avoid direct exposure to the beam.

Class 1 Laser Product  
Laser Klasse 1  
Laser Klass 1  
Luokan 1 Laserlaite  
Appareil À Laser de Classe 1

### Statement 4



**CAUTION:**  
Use safe practices when lifting.

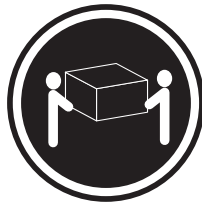

≥ 18 kg (39.7 lb)



≥ 32 kg (70.5 lb)

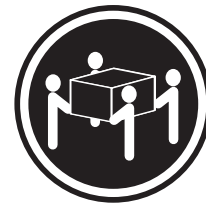

≥ 55 kg (121.2 lb)

### Statement 5



**CAUTION:**  
The power control button on the device and the power switch on the power supply do not turn off the electrical current supplied to the device. The device also might have more than one power cord. To remove all electrical current from the device, ensure that all power cords are disconnected from the power source.

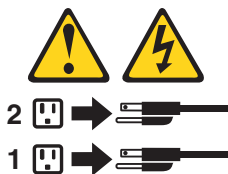

### Statement 6



**CAUTION:**

If you install a strain-relief bracket option over the end of the power cord that is connected to the device, you must connect the other end of the power cord to an easily accessible power source.

### Statement 8



**CAUTION:**

Never remove the cover on a power supply or any part that has the following label attached.



Hazardous voltage, current, and energy levels are present inside any component that has this label attached. There are no serviceable parts inside these components. If you suspect a problem with one of these parts, contact a service technician.

### Statement 12



**CAUTION:**

The following label indicates a hot surface nearby.



### Statement 26



**CAUTION:**

Do not place any object on top of rack-mounted devices.



**Rack Safety Information, Statement 2**



**DANGER**

- Always lower the leveling pads on the rack cabinet.
- Always install stabilizer brackets on the rack cabinet.
- Always install servers and optional devices starting from the bottom of the rack cabinet.
- Always install the heaviest devices in the bottom of the rack cabinet.



---

## Chapter 1. The IBM System x3550 M3 server

This publication contains information and instructions for setting up your IBM System x3550 M3 server, instructions for installing some optional devices, cabling and configuring the server, removing and replacing devices, and diagnostics and troubleshooting information.

In addition to the instructions in Chapter 2, “Installing optional devices,” on page 35 for installing optional hardware devices, updating firmware and device drivers, and completing the installation, IBM Business Partners must also complete the steps in “Instructions for IBM Business Partners” on page 35.

The IBM System x3550 M3 Type 4254 and 7944 server is a 1-U-high<sup>1</sup> rack model server for high-volume network transaction processing. This high-performance, multi-core server is ideally suited for networking environments that require superior microprocessor performance, input/output (I/O) flexibility, and high manageability.

Performance, ease of use, reliability, and expansion capabilities were key considerations in the design of the server. These design features make it possible for you to customize the system hardware to meet your needs today and provide flexible expansion capabilities for the future.

The server comes with a limited warranty. For information about the terms of the warranty, see the *Warranty Information* document that comes with the server.

The server contains IBM X-Architecture technologies, which help increase performance and reliability. For more information, see “What your server offers” on page 10 and “Reliability, availability, and serviceability” on page 14.

You can obtain up-to-date information about the server and other IBM server products at <http://www.ibm.com/systems/x/>. At <http://www.ibm.com/support/mysupport/>, you can create a personalized support page by identifying IBM products that are of interest to you. From this personalized page, you can subscribe to weekly email notifications about new technical documents, search for information and downloads, and access various administrative services.

If you participate in the IBM client reference program, you can share information about your use of technology, best practices, and innovative solutions; build a professional network; and gain visibility for your business. For more information about the IBM client reference program, see <http://www.ibm.com/ibm/clientreference/>.

If firmware and documentation updates are available, you can download them from the IBM website. The server might have features that are not described in the documentation that comes with the server, and the documentation might be updated occasionally to include information about those features, or technical

---

1. Racks are marked in vertical increments of 1.75 inches each. Each increment is referred to as a unit, or a “U”. A 1-U-high device is approximately 1.75 inches tall.

updates might be available to provide additional information that is not included in the server documentation. To check for updates, go to <http://www.ibm.com/supportportal/>.

**Note:** The illustrations in this document might differ slightly from your model.

The hot-swap server models support up to eight 2.5-inch hot-swap SAS/SATA hard disk drives. The simple-swap server models support up to four 2.5-inch simple-swap SATA hard disk drives. The following illustration shows the hot-swap server model.

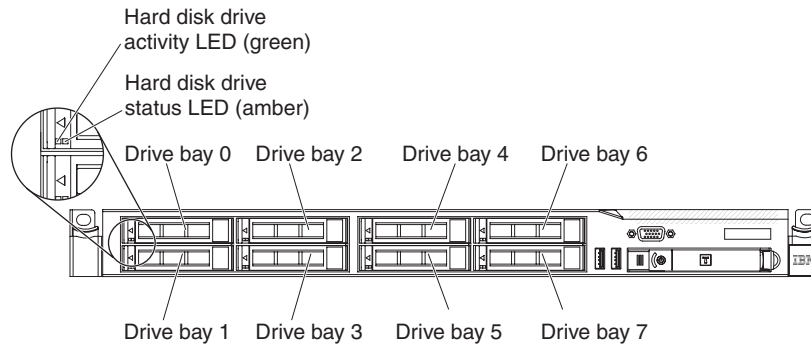

Figure 1. Front view: 2.5-inch model

On server models with an optional optical drive bay, the servers support up to four 2.5-inch simple-swap SATA or hot-swap SAS/SATA hard disk drives.

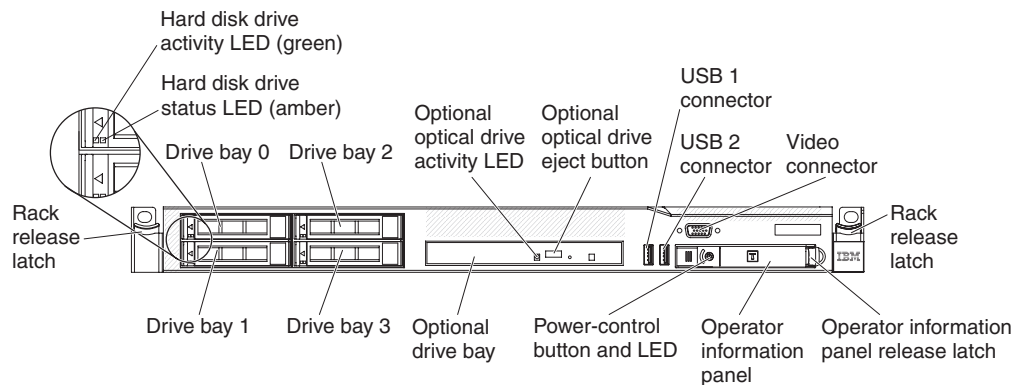

Figure 2. Front view: 2.5-inch model with optical drive bay

If firmware and documentation updates are available, you can download them from the IBM Web site. The server might have features that are not described in the documentation that comes with the server, and the documentation might be updated occasionally to include information about those features, or technical updates might be available to provide additional information that is not included in the server documentation. To check for updates, go to <http://www.ibm.com/supportportal/>.

Record information about the server in the following table.

<b>Product name</b>	IBM System x3550 M3 server
<b>Machine type</b>	4254 or 7944

<b>Model number</b>	_____
<b>Serial number</b>	_____

The model number and serial number are on the ID label on the front of the server, as shown in the following illustration.

**Note:** The illustrations in this document might differ slightly from your hardware.

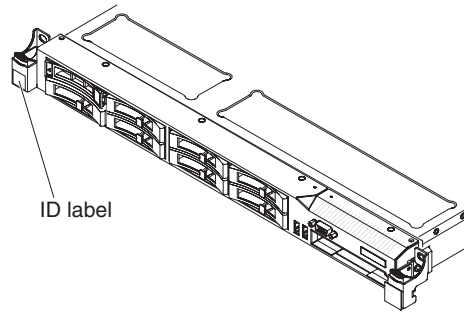

Figure 3. ID label

You can download an IBM *ServerGuide Setup and Installation* CD to help you configure the hardware, install device drivers, and install the operating system.

For a list of supported optional devices for the server, see <http://www.ibm.com/systems/info/x86servers/serverproven/compat/us/>.

See the *Rack Installation Instructions* document on the IBM *System x Documentation* CD for complete rack installation and removal instructions.

---

## The IBM Documentation CD

The IBM *Documentation* CD contains documentation for the server in Portable Document Format (PDF) and includes the IBM Documentation Browser to help you find information quickly.

### Hardware and software requirements

The IBM *Documentation* CD requires the following minimum hardware and software:

- Microsoft Windows XP, Windows 2000, or Red Hat Linux
- 100 MHz microprocessor
- 32 MB of RAM
- Adobe Acrobat Reader 3.0 (or later) or xpdf, which comes with Linux operating systems

## Using the Documentation Browser

Use the Documentation Browser to browse the contents of the CD, read brief descriptions of the documents, and view documents, using Adobe Acrobat Reader or xpdf.

The Documentation Browser automatically detects the regional settings in use in your server and displays the documents in the language for that region (if available). If a document is not available in the language for that region, the English-language version is displayed.

Use one of the following procedures to start the Documentation Browser:

- If Autostart is enabled, insert the CD into the CD or DVD drive. The Documentation Browser starts automatically.
- If Autostart is disabled or is not enabled for all users, use one of the following procedures:

- If you are using a Windows operating system, insert the CD into the CD or DVD drive and click **Start > Run**. In the **Open** field, type

```
e:\win32.bat
```

where *e* is the drive letter of the CD or DVD drive, and click **OK**.

- If you are using Red Hat Linux, insert the CD into the CD or DVD drive; then, run the following command from the `/mnt/cdrom` directory:

```
sh runlinux.sh
```

Select the server from the **Product** menu. The **Available Topics** list displays all the documents for the server. Some documents might be in folders. A plus sign (+) indicates each folder or document that has additional documents under it. Click the plus sign to display the additional documents.

When you select a document, a description of the document is displayed under **Topic Description**. To select more than one document, press and hold the `Ctrl` key while you select the documents. Click **View** to view the selected document or documents in Acrobat Reader or xpdf. If you selected more than one document, all the selected documents are opened in Acrobat Reader or xpdf.

To search all the documents, type a word or word string in the **Search** field and click **Search**. The documents in which the word or word string appears are listed in order of the most occurrences. Click a document to view it, and press `Ctrl+F` to use the Acrobat search function, or press `Alt+F` to use the xpdf search function within the document.

Click **Help** for detailed information about using the Documentation Browser.

---

## Related documentation

This publication contains general information about the server including how to set up and cable the server, how to install supported optional devices, how to configure the server, and information to help you solve problems yourself and information for service technicians. The following documentation also comes with the server:

- *Environmental Notices and User Guide*

This document is in PDF format on the IBM *Documentation CD*. It contains translated environmental notices.

- *IBM License Agreement for Machine Code*

This document is in PDF format on the IBM *Documentation CD*. It provides translated versions of the *IBM License Agreement for Machine Code* for your product.

- *Important Notices*

This document is in printed format and comes with the server. It contains information about the safety, environmental, and electronic emission notices for your IBM product.

- *Licenses and Attributions Documents*

This document is in PDF format on the IBM *Documentation CD*. It provides the open source notices.

- *Rack Installation Instructions*

This printed document contains instructions for installing the server in a rack and comes with the rack kit.

- *Rack Safety Information*

This multilingual document provides translated versions of the caution and danger statements that appear in the rack documentation. Each caution and danger statement has an assigned number, which you can use to locate the corresponding statement in your native language.

- *Safety Information*

This document is in PDF format on the IBM *Documentation CD*. It contains translated caution and danger statements. Each caution and danger statement that appears in the documentation has a number that you can use to locate the corresponding statement in your language in the *Safety Information* document.

- *Safety Information Labels*

This document provides the Simplified Chinese, Mongolian, Tibetan, Uyghur, and Zhuang translated versions of the product safety labels.

- *Warranty Information*

This document is in printed format and comes with the server. It contains warranty terms and a pointer to the IBM Statement of Limited Warranty on the IBM website.

Depending on the server model, additional documentation might be included on the IBM *Documentation CD*.

The ToolsCenter for System x and BladeCenter is an online information center that contains information about tools for updating, managing, and deploying firmware, device drivers, and operating systems. The ToolsCenter for System x and BladeCenter is at <http://publib.boulder.ibm.com/infocenter/toolctr/v1r0/>.

The server might have features that are not described in the documentation that you received with the server. The documentation might be updated occasionally to include information about those features, or technical updates might be available to provide additional information that is not included in the server documentation. These updates are available from the IBM website. To check for updates, go to <http://www.ibm.com/supportportal/>.

---

## Notices and statements in this document

The caution and danger statements in this document are also in the multilingual *Safety Information* document, which is on the IBM *System x Documentation* CD. Each statement is numbered for reference to the corresponding statement in your language in the *Safety Information* document.

The following notices and statements are used in this document:

- **Note:** These notices provide important tips, guidance, or advice.
- **Important:** These notices provide information or advice that might help you avoid inconvenient or problem situations.
- **Attention:** These notices indicate potential damage to programs, devices, or data. An attention notice is placed just before the instruction or situation in which damage might occur.
- **Caution:** These statements indicate situations that can be potentially hazardous to you. A caution statement is placed just before the description of a potentially hazardous procedure step or situation.
- **Danger:** These statements indicate situations that can be potentially lethal or extremely hazardous to you. A danger statement is placed just before the description of a potentially lethal or extremely hazardous procedure step or situation.

---

## Features and specifications

The following information is a summary of the features and specifications of the server.

Depending on the server model, some features might not be available, or some specifications might not apply.

Table 1. Features and specifications

<p><b>Microprocessor:</b></p> <ul style="list-style-type: none"> <li>• Supports up to two Intel Xeon™ multi-core microprocessors (one installed)</li> <li>• Level-3 cache</li> <li>• QuickPath Interconnect (QPI) links speed up to 6.4 GT per second</li> </ul> <p><b>Notes:</b></p> <ul style="list-style-type: none"> <li>• Do not install an Intel Xeon™ 5500 series microprocessor and an Xeon™ 5600 series microprocessor in the same server.</li> <li>• Use the Setup utility program to determine the type and speed of the microprocessors.</li> <li>• For a list of supported microprocessors, see <a href="http://www.ibm.com/systems/info/x86servers/serverproven/compat/us/">http://www.ibm.com/systems/info/x86servers/serverproven/compat/us/</a>.</li> </ul> <p><b>Memory:</b></p> <ul style="list-style-type: none"> <li>• Minimum: 2 GB</li> <li>• Maximum: 288 GB <ul style="list-style-type: none"> <li>– 48 GB using unbuffered DIMMs (UDIMMs)</li> <li>– 288 GB using registered DIMMs (RDIMMs)</li> </ul> </li> <li>• Type: PC3-10600R-999, 800, 1066, and 1333 MHz, ECC, DDR3 registered or unbuffered SDRAM DIMMs</li> <li>• Slots: 18 dual inline</li> <li>• Supports (depending on the model): <ul style="list-style-type: none"> <li>– 2 GB and 4 GB unbuffered DIMMs</li> <li>– 2 GB, 4 GB, 8 GB, and 16 GB registered DIMMs</li> </ul> </li> </ul> <p><b>SATA optical drives (optional):</b></p> <ul style="list-style-type: none"> <li>• DVD-ROM</li> <li>• Multi-burner</li> </ul> <p><b>Hot-swap fans:</b></p> <p>The server comes standard with five dual-motor hot-swap fans.</p>	<p><b>Hard disk drive expansion bays (depending on the model):</b></p> <ul style="list-style-type: none"> <li>• Up to eight 2.5-inch hot-swap SAS or hot-swap SATA hard disk drive bays</li> <li>• Up to four 2.5-inch hot-swap SAS/SATA or simple-swap SATA hard disk drive bays (on server models with an optional optical drive bay)</li> </ul> <p><b>PCI expansion slots:</b></p> <p>Supports two PCI riser slots:</p> <ul style="list-style-type: none"> <li>• Slot 1 supports low-profile cards (PCI Express Gen2 x16 or PCI-X 1.0a 64-bit/133 MHz).</li> <li>• Slot 2 supports half-length, full-height cards (PCI Express Gen2 x16 or PCI-X 1.0a 64-bit/133 MHz).</li> </ul> <p><b>Video controller (integrated into IMM):</b></p> <ul style="list-style-type: none"> <li>• Matrox G200eV (two analog ports - one front and one rear that can be connected at the same time)</li> </ul> <p><b>Notes:</b> The maximum video resolution is 1600 x 1200 at 75 Hz.</p> <ul style="list-style-type: none"> <li>– SVGA compatible video controller</li> <li>– DDR2 250 MHz SDRAM video memory controller</li> <li>– Avocent Digital Video Compression</li> <li>– 16 MB of video memory (not expandable)</li> </ul>	<p><b>Power supply:</b></p> <ul style="list-style-type: none"> <li>• Maximum of two hot-swap power supplies for redundancy support <ul style="list-style-type: none"> <li>– 460-watt ac</li> <li>– 675-watt ac</li> <li>– 675-watt high-efficiency ac</li> <li>– 675-watt dc</li> </ul> </li> </ul> <p><b>Note:</b> You cannot mix 460-watt and 675-watt power supplies, high-efficiency and non-high-efficiency power supplies, or ac and dc power supplies in the server.</p> <p><b>Environment:</b></p> <ul style="list-style-type: none"> <li>• Air temperature: <ul style="list-style-type: none"> <li>– Server on: 10°C to 35°C (50°F to 95°F); altitude: 0 to 914.4 m (3000 ft), decrease system temperature by 1.0°C for every 1000-foot increase in altitude</li> <li>– Server off: 5°C to 45°C (41°F to 113°F); maximum altitude: 3048 m (10000 ft)</li> <li>– Shipment: -40°C to 60°C (-40°F to 140°F); maximum altitude: 3048 m (10000 ft)</li> </ul> </li> <li>• Humidity: <ul style="list-style-type: none"> <li>– Server on: 20% to 80%; maximum dew point: 21°C; maximum rate of change: 5 °C/hr</li> <li>– Server off: 8% to 80%; maximum dew point: 27°C</li> </ul> </li> <li>• Particulate contamination: <p><b>Attention:</b> Airborne particulates and reactive gases acting alone or in combination with other environmental factors such as humidity or temperature might pose a risk to the server. For information about the limits for particulates and gases, see “Particulate contamination” on page 139.</p> </li> </ul> <p><b>Heat output:</b></p> <p>Approximate heat output:</p> <ul style="list-style-type: none"> <li>• Minimum configuration: 662 Btu per hour (194 watts)</li> <li>• Maximum configuration: 2302 Btu per hour (675 watts)</li> </ul>
--	--	--

Table 1. Features and specifications (continued)

<p><b>Integrated functions:</b></p> <ul style="list-style-type: none"> <li>• Integrated Management Module (IMM), which provides service processor control and monitoring functions, video controller, and (when the optional virtual media key is installed) remote keyboard, video, mouse, and remote hard disk drive capabilities</li> <li>• Broadcom BCM5709 Gb Ethernet controller with TCP/IP Offload Engine (TOE) and Wake on LAN support</li> <li>• Five Universal Serial Bus (USB) 2.0 ports (two front and two rear of the chassis, and one on the SAS/SATA RAID riser card in which the optional USB flash device with embedded hypervisor software is installed)</li> <li>• Four Ethernet ports (two on system board and two additional ports when the optional IBM Dual-Port 1 Gb Ethernet Daughter Card is installed)</li> <li>• One System Management RJ-45 on the rear to connect to a systems management network. This system management connector is dedicated to the IMM functions. This connector is active with or without the optional IBM Virtual Media Key installed.</li> <li>• One serial port</li> </ul>	<p><b>RAID controllers (depending on the model):</b></p> <ul style="list-style-type: none"> <li>• A ServeRAID-BR10i v2 SAS/SATA adapter that provides RAID levels 0, 1, and 1E (comes standard on some hot-swap models).</li> <li>• An optional ServeRAID-BR10i SAS/SATA adapter that provides RAID levels 0, 1, and 1E can be ordered.</li> <li>• An optional ServeRAID-MR10i SAS/SATA adapter that provides RAID levels 0, 1, 5, 6, 10, 50, and 60 can be ordered.</li> <li>• An optional ServerRAID M1015 SAS/SATA adapter that provides RAID levels 0, 1, and 10 with optional RAID 5/50 and SED (Self Encrypting Drive) upgrade.</li> <li>• An optional ServeRAID M5014 SAS/SATA adapter that provides RAID levels 0, 1, 5, 10 and 50 with optional RAID 6/60 and SED upgrade.</li> <li>• An optional ServeRAID M5015 SAS/SATA adapter that provides RAID levels 0, 1, 5, 10, and 50 with optional RAID 6/60 and SED upgrade.</li> </ul> <p><b>Size:</b></p> <ul style="list-style-type: none"> <li>• 1U</li> <li>• Height: 43 mm (1.7 inches)</li> <li>• Depth: 711 mm (28.0 inches)</li> <li>• Width: 440 mm (17.3 inches)</li> <li>• Weight: approximately 15.9 kg (35.1 lb) when fully configured</li> </ul> <p><b>Acoustical noise emissions:</b></p> <ul style="list-style-type: none"> <li>• Sound power, idling: 6.1 bels maximum</li> <li>• Sound power, operating: 6.1 bels maximum</li> </ul>	<p><b>Electrical input:</b></p> <ul style="list-style-type: none"> <li>• Sine-wave input (47 - 63 Hz) required</li> <li>• Input voltage low range: <ul style="list-style-type: none"> <li>– Minimum: 100 V ac</li> <li>– Maximum: 127 V ac</li> </ul> </li> <li>• Input voltage high range: <ul style="list-style-type: none"> <li>– Minimum: 200 V ac</li> <li>– Maximum: 240 V ac</li> </ul> </li> <li>• Input kilovolt-amperes (kVA), approximately: <ul style="list-style-type: none"> <li>– Minimum: 0.090 kVA</li> <li>– Maximum: 0.700 kVA</li> </ul> </li> </ul> <p><b>Notes:</b></p> <ol style="list-style-type: none"> <li>1. Power consumption and heat output vary depending on the number and type of optional features installed and the power-management optional features in use.</li> <li>2. The sound levels were measured in controlled acoustical environments according to the procedures specified by the American National Standards Institute (ANSI) S12.10 and ISO 7779 and are reported in accordance with ISO 9296. Actual sound-pressure levels in a given location might exceed the average values stated because of room reflections and other nearby noise sources. The noise emission level stated in the declared (upper limit) sound-power level, in bels, for a random sample of system.</li> </ol>
--	---	--

**EU Regulation 617/2013 Technical Documentation:**

International Business Machines Corporation  
New Orchard Road  
Armonk, New York 10504  
<http://www.ibm.com/customersupport/>

For more information on the energy efficiency program, go to  
<http://www.ibm.com/systems/x/hardware/energy-star/index.html>

**Product Type:**  
Computer Server

**Year first manufactured:**  
2010

**Internal/external power supply efficiency:**  
PSU 1:

Table 2. Power supply efficiency (PSU 1)

IRMS A	PF	ITHD (%)	Load (%)	Input Watts	Output Watts	Efficiency %
0.41	0.811	39.8%	10%	77.25	67.50	87.38%
0.72	0.901	30.5%	20%	148.45	134.74	90.76%
1.65	0.956	21.8%	50%	361.99	336.34	92.91%
3.28	0.976	17.5%	100%	736.58	670.10	90.97%

PSU 2:

Table 3. Power supply efficiency (PSU 2)

IRMS A	PF	ITHD (%)	Load (%)	Input Watts	Output Watts	Efficiency %
0.50	0.694	19.02%	10%	79.4	68.2	85.9%
0.74	0.867	15.1%	20%	148.4	134.8	90.8%
1.63	0.968	4.85%	50%	362.1	336.1	93.0%
3.24	0.988	5.3%	100%	737.3	672.3	91.2%

**Maximum power (watts):**

See Power supply.

**Idle state power (watts):**

129

**Sleep mode power (watts):**

N/A for servers

**Off mode power (watts):**

Not available

**Noise levels (the declared A-weighted sound power level of the computer):**

See Acoustical noise emissions.

**Test voltage and frequency:**

230V / 50 Hz or 60 Hz

**Total harmonic distortion of the electricity supply system:**

The maximum harmonic content of the input voltage waveform will be equal or less than 2%. The qualification is compliant with EN 61000-3-2.

**Information and documentation on the instrumentation set-up and circuits used for electrical testing:**

ENERGY STAR Test Method for Computer Servers; ECOVA Generalized Test Protocol for Calculating the Energy Efficiency of Internal Ac-Dc and Dc-Dc Power Supplies.

**Measurement methodology used to determine information in this document:**

ENERGY STAR Servers Version 2.0 Program Requirements; ECOVA Generalized Test Protocol for Calculating the Energy Efficiency of Internal Ac-Dc and Dc-Dc Power Supplies.

---

## What your server offers

The server uses the following features and technologies.

- **Integrated Management Module**

The Integrated Management module (IMM) combines service processor functions, video controller, and (when an optional virtual media key is installed) remote presence function in a single chip. The IMM provides advanced service-processor control, monitoring, and alerting function. If an environmental condition exceeds a threshold or if a system component fails, the IMM lights LEDs to help you diagnose the problem, records the error in the event log, and alerts you to the problem. Optionally, the IMM also provides a virtual presence capability for remote server management capabilities. The IMM provides remote server management through the following industry-standard interfaces:

- Intelligent Platform Management Interface (IPMI) version 2.0
- Simple Network Management Protocol (SNMP) version 3
- Common Information Model (CIM)
- Web browser

For additional information, see “Using the integrated management module” on page 122.

- **UEFI-compliant server firmware** IBM System x Server Firmware (server firmware) offers several features, including Unified Extensible Firmware Interface (UEFI) 2.1 compliance; Active Energy Manager technology; enhanced reliability, availability, and serviceability (RAS) capabilities; and basic input/output system (BIOS) compatibility support. UEFI replaces the BIOS and defines a standard interface between the operating system, platform firmware, and external devices. UEFI-compliant System x servers are capable of booting UEFI-compliant operating systems, BIOS-based operating systems, and BIOS-based adapters as well as UEFI-compliant adapters.

**Note:** The server does not support DOS (Disk Operating System).

- **IBM Dynamic System Analysis Preboot diagnostics programs**

The Dynamic System Analysis (DSA) Preboot diagnostics programs are stored on the integrated USB memory. It collects and analyzes system information to aid in diagnosing server problems. The diagnostic programs collect the following information about the server:

- System configuration
- Network interfaces and settings
- Installed hardware
- Light path diagnostics status
- Service processor status and configuration
- Vital product data, firmware, and UEFI (formerly BIOS) configuration
- Hard disk drive health
- RAID controller configuration
- Event logs for ServeRAID controllers and service processors

The diagnostic programs create a merged log that includes events from all collected logs. The information is collected into a file that you can send to IBM service and support. Additionally, you can view the information locally through a generated text report file. You can also copy the log to a removable media and view the log from a Web browser.

For additional information about DSA Preboot diagnostics, see the *Problem Determination and Service Guide* on the *IBM System x Documentation CD*

- **Multi-core processing**

The server supports up to two Intel Xeon™ multi-core microprocessors. The server comes with only one microprocessor installed.

- **IBM Systems Director**

IBM Systems Director is a workgroup-hardware-management tool that you can use to centrally manage System x and xSeries servers. For more information, see the IBM Systems Director Information Center at [http://pic.dhe.ibm.com/infocenter/director/pubs/index.jsp?topic=%2Fcom.ibm.director.main.helps.doc%2Ffqm0\\_main.html](http://pic.dhe.ibm.com/infocenter/director/pubs/index.jsp?topic=%2Fcom.ibm.director.main.helps.doc%2Ffqm0_main.html) and “IBM Systems Director” on page 15.

- **IBM X-Architecture technology**

IBM X-Architecture technology combines proven, innovative IBM designs to make your Intel-processor-based server powerful, scalable, and reliable. For more information, see <http://www.ibm.com/systems/x/hardware/enterprise/xarchitecture.html>.

- **Active™ Memory**

The Active Memory feature improves the reliability of memory through memory mirroring. Memory mirroring mode replicates and stores data on two pairs of DIMMs within two channels simultaneously. If a failure occurs, the memory controller switches from the primary pair of memory DIMMs to the backup pair of DIMMs. For more information about installing DIMMs for memory mirroring, see “Installing a memory module” on page 54.

- **Remote presence capability and blue-screen capture**

The remote presence and blue-screen capture features are integrated functions of the Integrated Management Module (IMM) and are available with the purchase of the optional IBM Virtual Media Key. A virtual media key is required to enable the remote presence and blue-screen capture features. The remote presence feature provides the following functions:

- Remotely viewing video with graphics resolutions up to 1600 x 1200 at 75 Hz, regardless of the system state
- Remotely accessing the server, using the keyboard and mouse from a remote client
- Mapping the CD or DVD drive, diskette drive, and USB flash drive on a remote client, and mapping ISO and diskette image files as virtual drives that are available for use by the server
- Uploading a diskette image to the IMM memory and mapping it to the server as a virtual drive

The blue-screen capture feature captures the video display contents before the IMM restarts the server when the IMM detects an operating-system hang condition. A system administrator can use the blue-screen capture to assist in determining the cause of the hang condition.

See “Using the remote presence capability and blue-screen capture” on page 123 for additional information.

- **Large system-memory capacity**

The memory bus supports up to 192 GB of system memory when registered DIMMs are installed. The server supports up to 48 GB if unbuffered DIMMs are installed. The memory controller supports error correcting code (ECC) for up to 18 industry-standard PC3-10600R-999, 800, 1067, and 1333 MHz, DDR3 (third-generation double-data-rate), synchronous dynamic random access memory (SDRAM) dual inline memory modules (DIMMs).

- **IBM ServerGuide Setup and Installation CD**

The *ServerGuide Setup and Installation CD*, which you can download from the Web, provides programs to help you set up the server and install a Windows operating system. The ServerGuide program detects installed optional hardware devices and provides the correct configuration programs and device drivers. For more information about the *ServerGuide Setup and Installation CD*, see “Using the ServerGuide Setup and Installation CD” on page 120.

- **Integrated network support**

The server comes with an integrated dual-port Broadcom Gigabit Ethernet controller, which supports connection to a 10 Mbps, 100 Mbps, or 1000 Mbps network. For more information, see “Configuring the Gigabit Ethernet controller” on page 127.

- **Integrated Trusted Platform Module (TPM)**

This integrated security chip performs cryptographic functions and stores private and public secure keys. It provides the hardware support for the Trusted Computing Group (TCG) specification. You can download the software to support the TCG specification, when the software is available. See [http://www.ibm.com/servers/eserver/xseries/scalable\\_family.html](http://www.ibm.com/servers/eserver/xseries/scalable_family.html) for details about the TPM implementation. You can enable TPM support through the Setup utility under the **System Security** menu option.

- **Large data-storage capacity and hot-swap capability**

The hot-swap server models support a maximum of eight 2.5-inch hot-swap Serial Attached SCSI (SAS) hard disk drives or hot-swap Serial ATA (SATA) hard disk drives. The simple-swap server models support a maximum of four 2.5-inch simple-swap SATA hard disk drives.

With the hot-swap feature, you can add, remove, or replace hard disk drives without turning off the server.

- **Light path diagnostics**

Light path diagnostics provides LEDs to help you diagnose problems. For more information about the light path diagnostics, see “Light path diagnostics panel” on page 18 and the *Problem Determination and Service Guide* on the *IBM System x Documentation CD*.

- **PCI adapter capabilities**

The server has two PCI interface slots (one supports low-profile cards, and one supports half-length, full-height cards). Both slots can support PCI Express or PCI-X adapters through an optional PCI riser card. See “Installing an adapter” on page 70 for detailed information.

- **Active Energy Manager**

The IBM Active Energy Manager solution is an IBM Systems Director plug-in that measures and reports server power consumption as it occurs. This enables you to monitor power consumption in correlation to specific software application programs and hardware configurations. You can obtain the measurement values through the systems-management interface and view them, using IBM Systems Director. For more information, including the required levels of IBM Systems Director and Active Energy Manager, see the IBM Systems Director documentation on the *IBM Systems Director CD*, or see <http://www.ibm.com/systems/software/director/resources.html>.

- **Redundant connection**

The addition of the optional Ethernet daughter card provides failover capability to a redundant Ethernet connection with the applicable application installed. If a problem occurs with the primary Ethernet connection and the optional Ethernet daughter card is installed on the server, all Ethernet traffic that is associated with the primary connection is automatically switched to the optional redundant

Ethernet daughter card connection. If the applicable device drivers are installed, this switching occurs without data loss and without user intervention.

- **Redundant cooling and optional power capabilities**

The server supports a maximum of two 675-watt or 460-watt hot-swap power supplies and six dual-motor hot-swap fans, which provide redundancy and hot-swap capability for a typical configuration. The redundant cooling by the fans in the server enables continued operation if one of the fans fails. The server comes with one 675-watt or 460-watt hot-swap power supply and five fans.

You must install the sixth fan when you install the second microprocessor in the server. You can order the second optional power supply for power redundancy.

**Note:** You cannot mix 460-watt and 675-watt power supplies, high-efficiency and non-high-efficiency power supplies, or ac and dc power supplies in the server.

- **ServeRAID support**

The ServeRAID adapter provides hardware redundant array of independent disks (RAID) support to create configurations. The standard RAID adapter provides RAID levels 0, 1, and 1E. An optional RAID adapter is available for purchase.

- **Systems-management capabilities**

The server comes with an integrated management module (IMM). When the IMM is used with the systems-management software that comes with the server, you can manage the functions of the server locally and remotely. The IMM also provides system monitoring, event recording, and network alert capability. The system-management connector on the rear of the server is dedicated to the IMM. The dedicated system-management connector provides additional security by physically separating the management network traffic from the production network. You can use the Setup utility to configure the server to use a dedicated systems-management network or a shared network.

- **TCP/IP offload engine (TOE) support**

The Ethernet controllers in the server support TOE, which is a technology that offloads the TCP/IP flow from the microprocessor and I/O subsystem to increase the speed of the TCP/IP flow. When an operating system that supports TOE is running on the server and TOE is enabled, the server supports TOE operation. See the operating-system documentation for information about enabling TOE.

**Note:** As of the date of this document, the Linux operating system does not support TOE.

---

## Reliability, availability, and serviceability

Three important computer design features are reliability, availability, and serviceability (RAS). The RAS features help to ensure the integrity of the data that is stored in the server, the availability of the server when you need it, and the ease with which you can diagnose and correct problems.

Your server has the following RAS features:

- 3-year parts and 3-year labor limited warranty for machine type 7944 and 4-year parts and 4-year labor limited warranty for machine type 4254
- Automatic error retry and recovery
- Automatic restart on nonmaskable interrupt (NMI)
- Automatic restart after a power failure
- Backup basic input/output system switching under the control of the Integrated Management Module (IMM)
- Built-in monitoring for fan, power, temperature, voltage, and power-supply redundancy
- Cable-presence detection on most connectors
- Chipkill memory protection
- Diagnostic support for ServeRAID and Ethernet adapters
- Error codes and messages
- Error correcting code (ECC) L2 cache and system memory
- Hot-swap cooling fans with speed-sensing capability
- Hot-swap hard disk drives
- Information and light path diagnostics LED panels
- Integrated Management Module (IMM)
- Menu-driven setup, system configuration, and redundant array of independent disks (RAID) configuration programs
- Microprocessor built-in self-test (BIST), internal error signal monitoring, configuration checking, and microprocessor and voltage regulator module failure identification through light path diagnostics
- Memory mirroring support (memory mirroring are mutually exclusive of each other)
- Parity checking on the small computer system interface (SCSI) bus and PCI buses
- Power management: Compliance with Advanced Configuration and Power Interface (ACPI)
- Power-on self-test (POST)
- Predictive Failure Analysis (PFA) alerts on memory, SAS/SATA hard disk drives, fans, and power supplies
- Redundant Ethernet capabilities with failover support
- Redundant hot-swap power supplies and redundant hot-swap fans
- Redundant Network Interface Card (NIC) support
- Remind button to temporarily turn off the system-error LED
- Remote system problem-determination support
- ROM-based diagnostics
- ROM checksums
- Serial Presence Detection (SPD) on memory, VPD, power supply, and hard disk drives backplane
- Single-DIMM isolation of excessive correctable error or multi-bit error by the Unified Extensible Firmware Interface (UEFI)
- Standby voltage for system-management features and monitoring
- Startup (boot) from LAN through remote initial program load (RIPL) or dynamic host configuration protocol/boot protocol (DHCP/BOOTP)
- System auto-configuring from the configuration menu
- System-error logging (POST and IMM)

- Systems-management monitoring through the Inter-Integrated Circuit (IC) protocol bus
- Upgradeable POST, Unified Extensible Firmware Interface (UEFI), diagnostics, IMM firmware, and read-only memory (ROM) resident code, locally or over the LAN
- Vital product data (VPD) on microprocessors, system board, power supplies, and SAS/SATA (hot-swap hard disk drive) backplane
- Wake on LAN capability

---

## IBM Systems Director

IBM Systems Director is a platform-management foundation that streamlines the way you manage physical and virtual systems supports multiple operating systems and virtualization technologies in IBM and non-IBM x86 platforms.

Through a single user interface, IBM Systems Director provides consistent views for viewing managed systems, determining how these systems relate to one other, and identifying their statuses, helping to correlate technical resources with business needs. A set of common tasks that are included with IBM Systems Director provides many of the core capabilities that are required for basic management, which means instant out-of-the-box business value. The common tasks include the following:

- Discovery
- Inventory
- Configuration
- System health
- Monitoring
- Updates
- Event notification
- Automation for managed systems

The IBM Systems Director Web and command-line interfaces provide a consistent interface that is focused on driving these common tasks and capabilities:

- Discovering, navigating, and visualizing systems on the network with the detailed inventory and relationships to the other network resources
- Notifying users of problems that occur on systems and the ability to isolate the sources of the problems
- Notifying users when systems need updates and distributing and installing updates on a schedule
- Analyzing real-time data for systems and setting critical thresholds that notify the administrator of emerging problems
- Configuring settings of a single system and creating a configuration plan that can apply those settings to multiple systems
- Updating installed plug-ins to add new features and functions to the base capabilities
- Managing the life cycles of virtual resources

For more information about IBM Systems Director, see the documentation on the *IBM Systems Director* CD that comes with the server and the IBM xSeries Systems Management Web page at <http://www.ibm.com/systems/management/>, which presents an overview of IBM Systems Management and IBM Systems Director.

---

## The UpdateXpress System Pack Installer

The UpdateXpress System Pack Installer detects supported and installed device drivers and firmware in the server and installs available updates.

For additional information and to download the UpdateXpress System Pack Installer, go to the ToolsCenter for System x and BladeCenter at <http://publib.boulder.ibm.com/infocenter/toolsctr/v1r0/> and click **UpdateXpress System Pack Installer**.

---

## Server controls, LEDs, and power

This section describes the controls and light-emitting diodes (LEDs) and how to turn the server on and off.

For the location of the LEDs on the system board, see “System-board LEDs” on page 41.

### Front view

Use this information to view the controls, LEDs, and connectors on the front of the server.

The following illustration shows the controls, LEDs, and connectors on the front of the server.

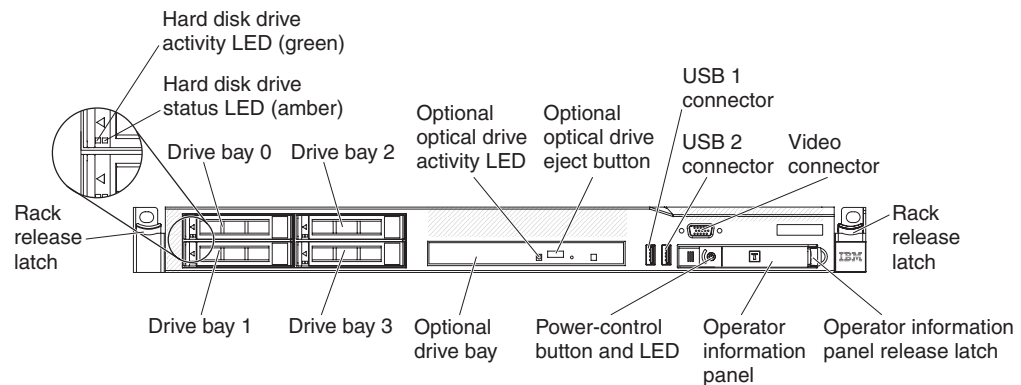

Figure 4. Front view

The following illustration shows the front of the simple-swap server model.

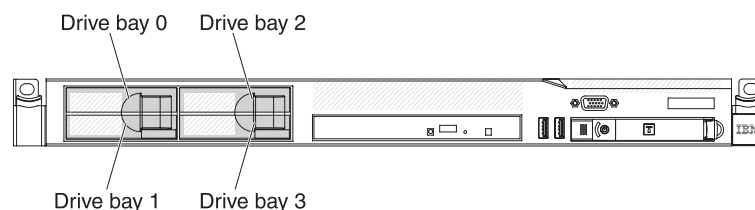

Figure 5. Front view: simple-swap HDD model

- **Rack release latches:** Press the latches on each front side of the server to remove the server from the rack.

- **Hard disk drive activity LEDs:** This LED is used on hot-swap SAS or SATA hard disk drives. Each hot-swap hard disk drive has an activity LED, and when this LED is flashing, it indicates that the drive is in use.
- **Hard disk drive status LEDs:** This LED is used on hot-swap SAS or SATA hard disk drives. When this LED is lit, it indicates that the drive has failed. If an optional IBM ServeRAID controller is installed in the server, when this LED is flashing slowly (one flash per second), it indicates that the drive is being rebuilt. When the LED is flashing rapidly (three flashes per second), it indicates that the controller is identifying the drive.
- **Optional DVD eject button:** Press this button to release a DVD or CD from the DVD drive.
- **Optional DVD drive activity LED:** When this LED is lit, it indicates that the DVD drive is in use.
- **Operator information panel:** This panel contains controls and LEDs that provide information about the status of the server.
- **Operator information panel release latch:** Slide the blue release latch to the left to pull out the light path diagnostics panel and view the light path diagnostics LEDs and buttons. See “Light path diagnostics panel” on page 18 for more information about the light path diagnostics.
- **Video connector:** Connect a monitor to this connector. The video connectors on the front and rear of the server can be used simultaneously.
- **USB connectors:** Connect a USB device, such as a USB mouse or keyboard to any of these connectors.

## Operator information panel

Use this information to view the operator information panel.

The following illustration shows the controls and LEDs on the operator information panel.

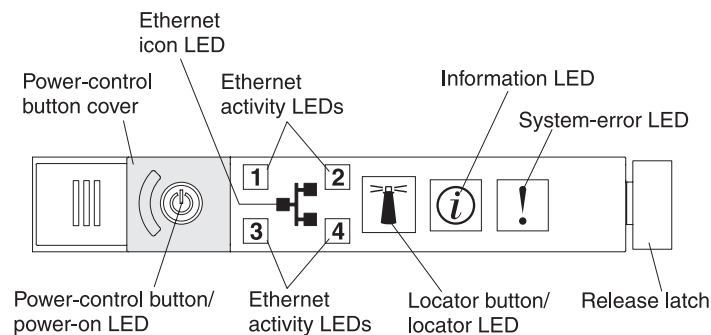

Figure 6. Operator information panel

- **Power-control button and power-on LED:** Press this button to turn the server on and off manually or to wake the server from a reduced-power state. The states of the power-on LED are as follows:
  - Off:** AC power is not present, or the power supply or the LED itself has failed.
  - Flashing rapidly (4 times per second):** The server is turned off and is not ready to be turned on. The power-control button is disabled. This will last approximately 20 to 40 seconds.
  - Flashing slowly (once per second):** The server is turned off and is ready to be turned on. You can press the power-control button to turn on the server.

**Lit:** The server is turned on.

**Fading on and off:** The server is in a reduced-power state. To wake the server, press the power-control button or use the IMM web interface. See “Logging on to the Web interface” on page 125 for information on logging on to the IMM web interface.

- **Ethernet activity LEDs:** When any of these LEDs is lit, they indicate that the server is transmitting to or receiving signals from the Ethernet LAN that is connected to the Ethernet port that corresponds to that LED.
- **System-locator button/LED:** Use this blue LED to visually locate the server among other servers. This LED is also used as a presence detection button. You can use IBM Systems Director to light this LED remotely. This LED is controlled by the IMM. When you press the System-locator button, the LED will blink and it will continue to blink until you press it again to turn it off. The locator button is pressed to visually locate the server among the others servers.
- **System-information LED:** When this amber LED is lit, it indicates that a noncritical event has occurred. Check the error log for additional information.
- **System-error LED:** When this amber LED is lit, it indicates that a system error has occurred. A system-error LED is also on the rear of the server. An LED on the light path diagnostics panel on the operator information panel is also lit to help isolate the error. This LED is controlled by the IMM.
- **Hard drive activity LED:** When this green LED is lit, it indicates that one of the hard disk drives is in use.

**Notes:**

1. For a SAS drive, a hard disk drive activity LED is shown in two places: on the hard disk drive and on the operator information panel.
2. For a SATA drive, hard disk drive activity is indicated only by the hard disk drive activity LED on the operator information panel.

## Light path diagnostics panel

The light path diagnostics panel is located on the top of the operator information panel.

**Note:** The system service label on the underside of the cover also provides information about the location of the light path diagnostics LEDs.

To access the light path diagnostics panel, slide the blue release latch on the operator panel to the left. Pull forward on the panel until the hinge of the operator panel is free of the server chassis. Then pull down on the panel, so that you can view the light path diagnostics panel information.

**Note:** When you slide the light path diagnostics panel out of the server to check the LEDs or checkpoint codes, do not run the server continuously with light path diagnostics panel outside of the server. The panel should only be outside of the server a short time. The light path diagnostics panel must remain in the server when the server is running to ensure proper cooling.

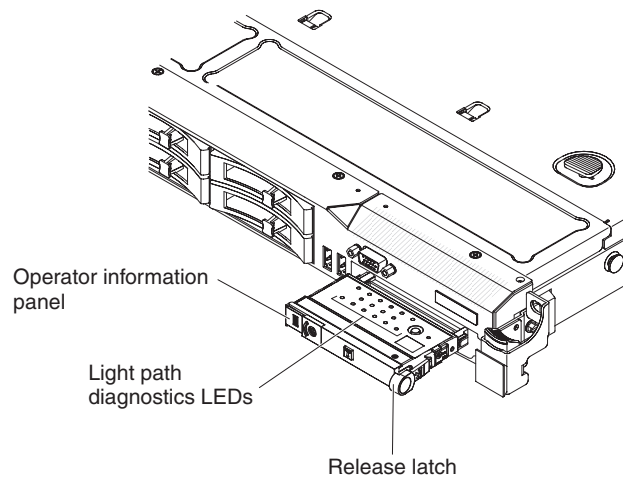

Figure 7. Light path diagnostics panel exposure

The following illustration shows the LEDs and controls on the light path diagnostics panel.

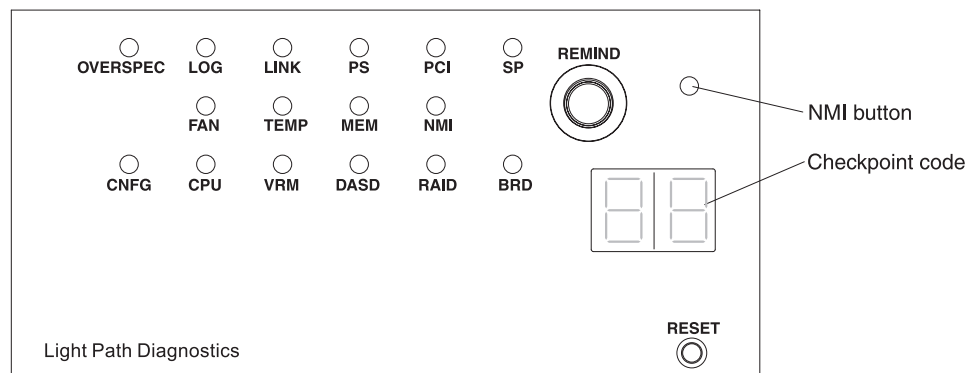

Figure 8. Light path diagnostics panel exposure

- **Remind button:** This button places the system-error LED on the front panel into Remind mode. In Remind mode, the system-error LED flashes every 2 seconds until the problem is corrected, the system is restarted, or a new problem occurs. By placing the system-error LED indicator in Remind mode, you acknowledge that you are aware of the last failure but will not take immediate action to correct the problem. The remind function is controlled by the IMM.
- **NMI button:** Press this button to force a nonmaskable interrupt to the microprocessor. It allows you to blue screen the server and take a memory dump (use this button only when directed by the IBM service support).
- **Checkpoint code display:** This display provides a checkpoint code that indicates the point at which the system stopped during the boot block and POST. A checkpoint code is either a byte or a word value that is produced by UEFI. The display does not provide error codes or suggest components to be replaced.
- **Reset button:** Press this button to reset the server and run the power-on self-test (POST). You might have to use a pen or the end of a straightened paper clip to press the button. The Reset button is in the lower right-hand corner of the light path diagnostics panel.

For additional information about the light path diagnostics panel LEDs, see “Light path diagnostics LEDs” on page 20.

## Light path diagnostics LEDs

The following table describes the LEDs on the light path diagnostics panel and suggested actions to correct the detected problems.

**Note:** Check the system-error log or system event log for additional information before replacing a FRU.

Table 4. Light path diagnostics panel LEDs

LED	Description	Action
None, but the system error LED is lit.	An error has occurred and cannot be isolated. The error is not represented by a path.	Use the Setup utility to check the system error log for information about the error.
OVER SPEC	The power supplies are using more power than their maximum rating.	<p>If the OVER SPEC LED on the light path diagnostics panel is lit, or any of the six 12 V channel error LEDs (A, B, C, D, E, or AUX) on the system board are lit, use one of the following procedures.</p> <p>If the 12 V channel A error LED is lit, complete the following steps:</p> <ol style="list-style-type: none"> <li>1. Turn off the server and disconnect the power from the server.</li> <li>2. Remove the optical drive, fans, hard disk drives, and hard disk drive backplane.</li> <li>3. Restart the server to see whether the problem remains.</li> <li>4. Reinstall each device that you removed in step 2 one at a time, starting the server each time, to isolate the failing device.</li> <li>5. Replace any failing device.</li> <li>6. (Trained service technician only) Replace the system board.</li> </ol> <p>If the 12 V channel B error LED is lit, complete the following steps:</p> <ol style="list-style-type: none"> <li>1. Turn off the server and disconnect the power from the server.</li> <li>2. Remove the PCI riser card in connector 1, all DIMMs, and the microprocessor in socket 2.</li> <li>3. Restart the server to see whether the problem remains.</li> <li>4. Reinstall each device that you removed in step 2 one at a time, starting the server each time, to isolate the failing device.</li> <li>5. Replace any failing device.</li> <li>6. (Trained service technician only) Replace the system board.</li> </ol> <p>(Continued on the next page)</p>

Table 4. Light path diagnostics panel LEDs (continued)

LED	Description	Action
OVER SPEC (Continued)	The power supplies are using more power than their maximum rating.	<p>If the 12 V channel C error LED is lit, complete the following steps:</p> <ol style="list-style-type: none"> <li>1. Turn off the server and disconnect the power from the server.</li> <li>2. Remove the SAS/SATA RAID riser card, DIMMs in connectors 1 through 9, and the microprocessor in socket 1. <b>Note:</b> The server will not power-on when the microprocessor in socket 1 or 2 is not installed in the server. (Trained service technician only) Toggle the switch block (SW4), bit 3 to allow the server to power-on. See "System-board switches and jumpers" on page 38 for the location of the SW4 switch block on the system board.</li> <li>3. Restart the server to see whether the problem remains.</li> <li>4. Reinstall each device that you removed in step 2 one at a time, starting the server each time, to isolate the failing device.</li> <li>5. Replace any failing device.</li> <li>6. (Trained service technician only) Replace the system board.</li> </ol> <p>If the 12 V channel D error LED is lit, complete the following steps:</p> <ol style="list-style-type: none"> <li>1. Turn off the server and disconnect the power from the server.</li> <li>2. (Trained service technician only) Remove the microprocessor in socket 1. <b>Note:</b> The server will not power-on when the microprocessor in socket 1 or 2 is not installed in the server. (Trained service technician only) Toggle the switch block (SW4), bit 3 to allow the server to power-on. See "System-board switches and jumpers" on page 38 for the location of the SW4 switch block on the system board.</li> <li>3. Restart the server to see whether the problem remains.</li> <li>4. (Trained service technician only) Reinstall the microprocessor in socket 1 and restart the server.</li> <li>5. Replace any failing device.</li> <li>6. (Trained service technician only) Replace the system board.</li> </ol> <p>(Continued on the next page.)</p>

Table 4. Light path diagnostics panel LEDs (continued)

LED	Description	Action
OVER SPEC (Continued)	The power supplies are using more power than their maximum rating.	<p>If the 12 V channel E error LED is lit, complete the following steps:</p> <ol style="list-style-type: none"> <li>1. Turn off the server and disconnect the power from the server.</li> <li>2. Remove the PCI riser card from PCI riser connector 2 and the microprocessor in socket 2.</li> <li>3. Restart the server to see whether the problem remains.</li> <li>4. Reinstall each device that you removed in step 2 one at a time, starting the server each time, to isolate the failing device.</li> <li>5. Replace any failing device.</li> <li>6. (Trained service technician only) Replace the system board.</li> </ol> <p>If the 12 V AUX channel error LED is lit, complete the following steps:</p> <ol style="list-style-type: none"> <li>1. Turn off the server and disconnect the power from the server.</li> <li>2. Remove all PCI Express and PCI-X cards, all PCI riser cards, the operator information panel, and the Ethernet adapter (if installed). <b>Note:</b> The server will not power-on when the microprocessor in socket 1 or 2 is not installed in the server. (Trained service technician only) Toggle the switch block (SW4), bit 3 to allow the server to power-on. See "System-board switches and jumpers" on page 38 for the location of the SW4 switch block on the system board.</li> <li>3. Restart the server to see whether the problem remains.</li> <li>4. Reinstall each device that was removed in step 2 one at a time, starting the server each time, to isolate the failing device.</li> <li>5. Replace any failing device.</li> <li>6. (Trained service technician only) Replace the system board.</li> </ol>
LOG	An error occurred.	Check the IMM system event log and the system-error log for information about the error. Replace any components that are identified in the error logs.
LINK	Reserved.	

Table 4. Light path diagnostics panel LEDs (continued)

LED	Description	Action
PS	Power supply 1 or 2 has failed. When both the PS and CNFG LEDs are lit, the power supply configuration is invalid.	<ol style="list-style-type: none"> <li>1. Check the power-supply that has an lit amber LED (see "Power-supply LEDs" on page 29).</li> <li>2. Make sure that the power supplies are seated correctly.</li> <li>3. Remove one of the power supplies to isolate the failed power supply.</li> <li>4. Make sure that both power supplies installed in the server are of the same type.</li> <li>5. Replace the failed power supply.</li> </ol>
PCI	An error has occurred on a PCI bus or on the system board. An additional LED is lit next to a failing PCI slot.	<ol style="list-style-type: none"> <li>1. Check the LEDs on the PCI slots to identify the component that caused the error.</li> <li>2. Check the system-error log for information about the error.</li> <li>3. If you cannot isolate the failing adapter by using the LEDs and the information in the system-error log, remove one adapter at a time from the failing PCI bus; and restart the server after each adapter is removed.</li> <li>4. Replace the following components, in the order shown, restarting the server each time: <ul style="list-style-type: none"> <li>• PCI riser card</li> <li>• (Trained service technician only) Replace the system board.</li> </ul> </li> <li>5. For more information, go to <a href="http://www.ibm.com/support/entry/portal/docdisplay?lnocid=SERV-CALL">http://www.ibm.com/support/entry/portal/docdisplay?lnocid=SERV-CALL</a>.</li> </ol>
SP	A service processor error has been detected.	<ol style="list-style-type: none"> <li>1. Shut down the system and remove the power cords from the server; then, reconnect the server to power and restart the server.</li> <li>2. Update the IMM firmware.</li> <li>3. (Trained service technician only) Replace the system board, if the problem remains.</li> <li>4. For more information, go to <a href="http://www.ibm.com/support/entry/portal/docdisplay?lnocid=SERV-CALL">http://www.ibm.com/support/entry/portal/docdisplay?lnocid=SERV-CALL</a>.</li> </ol>
FAN	A fan has failed, is operating too slowly, or has been removed. The TEMP LED might also be lit.	<ol style="list-style-type: none"> <li>1. Reseat the failing fan, which is indicated by a lit LED near the fan connector on the system board.</li> <li>2. Replace the failing fan, which is indicated by a lit LED near the fan connector on the system board. <b>Note:</b> If an LED near an unused fan connector on the system board is lit, a PCI riser-card assembly might be absent. Replace the PCI riser-card assembly. One PCI riser-card assembly must always be present in PCI connector 2.</li> </ol>

Table 4. Light path diagnostics panel LEDs (continued)

LED	Description	Action
TEMP	The system temperature has exceeded a threshold level. A failing fan can cause the TEMP LED to be lit.	<ol style="list-style-type: none"> <li>1. Make sure that the heat sink is seated correctly.</li> <li>2. Determine whether a fan has failed. If it has, replace it.</li> <li>3. Make sure that the room temperature is not too high. See "Features and specifications" on page 6 for the server temperature information.</li> <li>4. Make sure that the air vents are not blocked.</li> <li>5. For more information, go to <a href="http://www.ibm.com/support/entry/portal/docdisplay?lnocid=SERV-CALL">http://www.ibm.com/support/entry/portal/docdisplay?lnocid=SERV-CALL</a>.</li> </ol>
MEM	When only the MEM LED is lit, a memory error has occurred. When both the MEM and CNFG LEDs are lit, the memory configuration is invalid or the PCI Option ROM is out of resource.	<p><b>Note:</b> Each time you install or remove a DIMM, you must disconnect the server from the power source; then, wait 10 seconds before restarting the server.</p> <ol style="list-style-type: none"> <li>1. If the MEM LED and the CNFG LED are lit, complete the following step:               <ol style="list-style-type: none"> <li>a. Check the system-event log in the Setup utility or IMM error messages.</li> </ol> </li> <li>2. If the CNFG LED is not lit, the system might detect a memory error. Complete the following steps to correct the problem:               <ol style="list-style-type: none"> <li>a. Update the server firmware to the latest level.</li> <li>b. Reseat or swap the DIMMs.</li> <li>c. Check the system-event log in the Setup utility or IMM error messages.</li> </ol> </li> </ol>
NMI	A nonmaskable interrupt has occurred, or the NMI button was pressed.	Check the system-error log for information about the error.
CNFG	A hardware configuration error has occurred.	<ol style="list-style-type: none"> <li>1. If the CNFG LED and the CPU LED are lit, complete the following steps to correct the problem:               <ol style="list-style-type: none"> <li>a. Check the microprocessors that were just installed to make sure that they are compatible with each other.</li> <li>b. (Trained service technician only) Replace the incompatible microprocessor.</li> <li>c. Check the system-error logs for information about the error. Replace any components that are identified in the error log.</li> </ol> </li> <li>2. If the CNFG LED and the MEM LED are lit, complete the following step:               <ol style="list-style-type: none"> <li>a. Check the system-event log in the Setup utility or IMM error messages.</li> </ol> </li> <li>3. If the CNFG LED and the PS LED are lit, the system issues an invalid power configuration error. Make sure that both power supplies installed in the server are of the same type.</li> </ol>

Table 4. Light path diagnostics panel LEDs (continued)

LED	Description	Action
CPU	An invalid microprocessor configuration or a microprocessor has failed (both the CPU LED and the CNFG LED might be lit).	<ul style="list-style-type: none"> <li>1. If the CNFG LED is lit, the system issues an invalid microprocessor configuration error. Complete the following steps to correct the problem:               <ul style="list-style-type: none"> <li>a. Check the microprocessors that were just installed to make sure that they are compatible with each other and use the Setup utility and select <b>System Information &gt; System Summary &gt; Processor Details</b> to verify the microprocessors information.</li> <li>b. (Trained service technician only) Replace the incompatible microprocessor.</li> <li>c. Check the system-error logs for information about the error. Replace any components that are identified in the error log.</li> </ul> </li> <li>2. If a microprocessor failure occurs, complete the following steps:               <ul style="list-style-type: none"> <li>a. (Trained service technician only) Make sure that the failing microprocessor, which is indicated by a lit LED on the system board, is installed correctly.</li> <li>b. For more information, go to <a href="http://www.ibm.com/support/entry/portal/docdisplay?lnocid=SERV-CALL">http://www.ibm.com/support/entry/portal/docdisplay?lnocid=SERV-CALL</a>.</li> </ul> </li> </ul>
VRM	Reserved.	
DASD	A hard disk drive has failed or is missing.	<ul style="list-style-type: none"> <li>1. Check the LEDs on the hard disk drives for the drive with a lit status LED and reseal the hard disk drive.</li> <li>2. Reseat the hard disk drive backplane.</li> <li>3. For more information, see the "Hard disk drive problems".</li> <li>4. If the error remains, replace the following components in the order listed, restarting the server after each:               <ul style="list-style-type: none"> <li>a. Replace the hard disk drive.</li> <li>b. Replace the hard disk drive backplane.</li> </ul> </li> <li>5. If the error remains, replace the following components one at a time, in the order listed, restarting the server after each:               <ul style="list-style-type: none"> <li>a. Replace the hard disk drive.</li> <li>b. Replace the hard disk drive backplane.</li> </ul> </li> <li>6. If the problem remains, go to <a href="http://www.ibm.com/support/entry/portal/docdisplay?lnocid=SERV-CALL">http://www.ibm.com/support/entry/portal/docdisplay?lnocid=SERV-CALL</a>.</li> </ul>
RAID	Reserved.	

Table 4. Light path diagnostics panel LEDs (continued)

LED	Description	Action
BRD	An error has occurred on the system board.	<ol style="list-style-type: none"> <li>1. Check the LEDs on the system board to identify the component that caused the error. The BRD LED can be lit due to any of the following reasons: <ul style="list-style-type: none"> <li>• Battery</li> <li>• Missing PCI riser-card assembly</li> <li>• Failed voltage regulator</li> </ul> </li> <li>2. Check the system-error log for information about the error.</li> <li>3. Replace any failed or missing replacement components, such as the battery or PCI riser-card assembly.</li> <li>4. If a voltage regulator has failed, (trained service technician only) replace the system board.</li> </ol>

## Rear view

Use this information to view the controls, LEDs, and connectors on the rear of the server.

The following illustration shows the connectors and LEDs on the rear of the server.

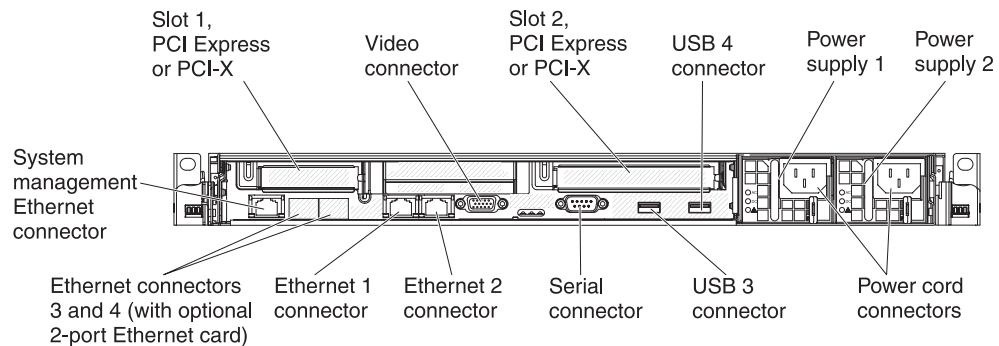

Figure 9. Rear view

- **PCI slot 1:** Insert a low-profile PCI Express or PCI-X adapter into this slot. You can purchase an optional PCI Express or PCI-X riser-card assembly with bracket if you want to install a PCI adapter in this slot.
- **PCI slot 2:** Insert a half-length, full-height PCI Express or PCI-X adapter into this slot. Standard models of the server come with one PCI Express riser-card assembly installed in this slot. You can purchase an optional PCI-X riser-card assembly with bracket if you want to install a PCI-X adapter in this slot.
- **Power cord connector:** Connect the power cord to this connector.
- **Video connector:** Connect a monitor to this connector. The video connectors on the front and rear of the server can be used simultaneously.

**Note:** The maximum video resolution is 1600 x 1200 at 75 Hz.

- **Serial connector:** Connect a 9-pin serial device to this connector. The serial port is shared with the integrated management module (IMM). The IMM can take control of the shared serial port to perform text console redirection and to redirect serial traffic, using Serial over LAN (SOL).
- **USB connectors:** Connect a USB device, such as a USB mouse or keyboard to any of these connectors.
- **Systems-management Ethernet connector:** Use this connector to connect the server to a network for full systems-management information control.
- **Ethernet connectors:** Use either of these connectors to connect the server to a network. When you use the Ethernet 1 connector, the network can be shared with the IMM through a single network cable.

The following illustration shows the LEDs on the rear of the server.

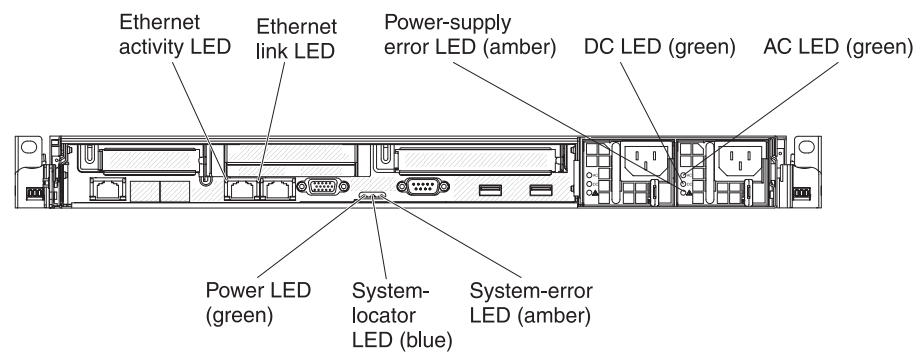

Figure 10. Rear view LEDs

The following illustration shows the LEDs on a dc power supply.

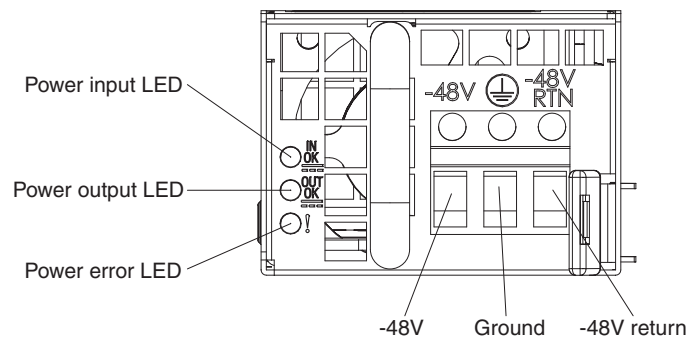

Figure 11. DC power supply LEDs

- **Ethernet activity LEDs:** When these LEDs are lit, they indicate that the server is transmitting to or receiving signals from the Ethernet LAN that is connected to the Ethernet port.
- **Ethernet link LEDs:** When these LEDs are lit, they indicate that there is an active link connection on the 10BASE-T, 100BASE-TX, or 1000BASE-TX interface for the Ethernet port.
- **AC power LED:** Each hot-swap ac power supply has an ac power LED and a dc power LED. When the ac power LED is lit, it indicates that sufficient power is coming into the power supply through the power cord. During typical

operation, both the ac and dc power LEDs are lit. For any other combination of LEDs, see “Power-supply LEDs” on page 29.

- **IN OK power LED:** Each hot-swap dc power supply has an IN OK power LED and an OUT OK power LED. When the IN OK power LED is lit, it indicates that sufficient power is coming into the power supply through the power cord. During typical operation, both the IN OK and OUT OK power LEDs are lit. For any other combination of LEDs, see “Power-supply LEDs” on page 29.
- **DC power LED:** Each hot-swap power supply has a dc power LED and an ac power LED. When the dc power LED is lit, it indicates that the power supply is supplying adequate dc power to the system. During typical operation, both the ac and dc power LEDs are lit. For any other combination of LEDs, see “Power-supply LEDs” on page 29.
- **OUT OK power LED:** Each hot-swap dc power supply has an IN OK power LED and an OUT OK power LED. When the OUT OK power LED is lit, it indicates that the power supply is supplying adequate dc power to the system. During typical operation, both the IN OK and OUT OK power LEDs are lit. For any other combination of LEDs, see “Power-supply LEDs” on page 29.
- **Power-supply error LED:** When the power-supply error LED is lit, it indicates that the power supply has failed.

**Note:** Power supply 1 is the default/primary power supply. If power supply 1 fails, you must replace the power supply immediately.

- **System-error LED:** When this LED is lit, it indicates that a system error has occurred. An LED on the light path diagnostics panel is also lit to help isolate the error.
- **Power-on LED:** When this LED is lit and not flashing, it indicates that the server is turned on. The states of the power-on LED are as follows:
  - Off:** Power is not present, or the power supply or the LED itself has failed.
  - Flashing rapidly (4 times per second):** The server is turned off and is not ready to be turned on. The power-control button is disabled. This will last approximately 20 to 40 seconds.
  - Flashing slowly (once per second):** The server is turned off and is ready to be turned on. You can press the power-control button to turn on the server.
  - Lit:** The server is turned on.
  - Fading on and off:** The server is in a reduced-power state. To wake the server, press the power-control button or use the IMM web interface. See “Logging on to the Web interface” on page 125 for information on logging on to the IMM web interface.
- **System-locator LED:** Use this LED to visually locate the server among other servers. You can use IBM Systems Director to light this LED remotely.

## Power-supply LEDs

Use this information to view power-supply LEDs.

The following minimum configuration is required for the server to start:

- One microprocessor in microprocessor socket 1
- One 2 GB DIMM for each microprocessor installed (one 2 GB DIMM in slot 3 if only one microprocessor installed)
- One power supply
- Power cord
- Five cooling fans (fan 1, 2, 3, 4, and 5)
- One PCI riser-card assembly in PCI connector 2
- One ServeRAID SAS/SATA controller

### AC power-supply LEDs:

Use this information to view AC power-supply LEDs.

The following illustration shows the location of the AC power-supply LEDs on the rear of the server. See the *Problem Determination and Service Guide* for additional information about solving power-supply problems.

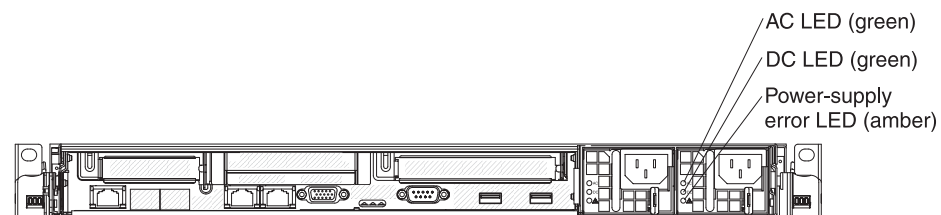

Figure 12. AC power-supply LEDs

The following table describes the problems that are indicated by various combinations of the power-supply LEDs on an ac power supply and suggested actions to correct the detected problems.

AC power-supply LEDs			Description	Action	Notes
AC	DC	Error (!)			
On	On	Off	Normal operation		
Off	Off	Off	No ac power to the server or a problem with the ac power source.	<ol style="list-style-type: none"> <li>1. Check the ac power to the server.</li> <li>2. Make sure that the power cord is connected to a functioning power source.</li> <li>3. Restart the server. If the error remains, check the power-supply LEDs.</li> <li>4. Replace the power-supply.</li> </ol>	This is a normal condition when no ac power is present.
Off	Off	On	No ac power to the server or a problem with the ac power source and the power-supply had detected an internal problem.	<ul style="list-style-type: none"> <li>• Make sure that the power cord is connected to a functioning power source.</li> <li>• Replace the power supply.</li> </ul>	This happens only when a second power supply is providing power to the server.

AC power-supply LEDs			Description	Action	Notes
AC	DC	Error (!)			
Off	On	Off	Faulty power-supply	Replace the power supply.	
Off	On	On	Faulty power-supply	Replace the power supply.	
On	Off	Off	Power-supply not fully seated, faulty system board, or faulty power-supply	<ol style="list-style-type: none"> <li>1. Reseat the power supply.</li> <li>2. If a power channel error LED on the system board is not lit, replace the power-supply (see the documentation that comes with the power supply for instructions).</li> <li>3. If a power channel error LED on the system board is lit, (trained service technician only) replace the system board.</li> </ol>	Typically indicates a power-supply is not fully seated.
On	Off	On	Faulty power-supply	Replace the power supply.	
On	On	On	Power-supply is faulty but still operational	Replace the power supply.	

### DC power-supply LEDs:

Use this information to view DC power-supply LEDs.

The following illustration shows the locations of the power-supply LEDs on the dc power supply.

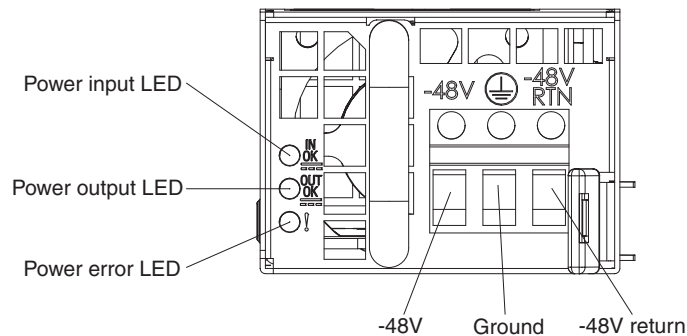

Figure 13. DC power-supply LEDs

The following table describes the problems that are indicated by various combinations of the power-supply LEDs on a dc power supply and suggested actions to correct the detected problems.

DC power-supply LEDs			Description	Action	Notes
IN OK	OUT OK	Error (!)			
On	On	Off	Normal operation		

DC power-supply LEDs			Description	Action	Notes
IN OK	OUT OK	Error (!)			
Off	Off	Off	No dc power to the server or a problem with the dc power source.	<ol style="list-style-type: none"> <li>1. Check the dc power to the server.</li> <li>2. Make sure that the power cord is connected to a functioning power source.</li> <li>3. Restart the server. If the error remains, check the power-supply LEDs.</li> <li>4. Replace the power-supply.</li> </ol>	This is a normal condition when no dc power is present.
Off	Off	On	No dc power to the server or a problem with the dc power source and the power-supply had detected an internal problem.	<ul style="list-style-type: none"> <li>• Make sure that the power cord is connected to a functioning power source.</li> <li>• Replace the power supply (see the documentation that comes with the power supply for instructions).</li> </ul>	
Off	On	Off	Faulty power-supply	Replace the power supply.	
Off	On	On	Faulty power-supply	Replace the power supply.	
On	Off	Off	Power-supply not fully seated, faulty system board, or faulty power-supply	<ol style="list-style-type: none"> <li>1. (Trained service technician only) Reseat the power supply.</li> <li>2. If a power channel error LED on the system board is not lit, replace the power-supply (see the documentation that comes with the power supply for instructions).</li> <li>3. If a power channel error LED on the system board is lit, (trained service technician only) replace the system board.</li> </ol>	Typically indicates a power-supply is not fully seated.
On	Off	On	Faulty power-supply	Replace the power supply.	
On	On	On	Power-supply is faulty but still operational	Replace the power supply.	

## System pulse LEDs

The following LEDs are on the system board and monitors the system power-on and power-off sequencing and boot progress.

See “System-board LEDs” on page 41 for the location of these LEDs.

Table 5. System pulse LEDs

LED	Description	Action
Enclosure management heartbeat	Power-on and power-off sequencing.	<ol style="list-style-type: none"> <li>1. If the LED blinks at 1Hz, it is functioning properly and no action is necessary.</li> <li>2. If the LED is not blinking, (trained service technician only) replace the system board.</li> </ol>
IMM heartbeat	IMM heartbeat boot process.	<p>The following steps describe the different stages of the IMM heartbeat sequencing process.</p> <ol style="list-style-type: none"> <li>1. When this LED is blinking fast (approximately 4Hz), this indicates, that the IMM code is in the loading process.</li> <li>2. When this LED goes off momentarily, this indicates that the IMM code has loaded completely.</li> <li>3. When this LED goes off momentarily and then starts blinking slowing (approximately 1Hz), this indicates that IMM is fully operational. You can now press the power-control button to power-on the server.</li> <li>4. If this LED does not blink within 30 seconds of connecting a power source to the server, complete the following steps: <ol style="list-style-type: none"> <li>a. (Trained service technician only) use the IMM recovery jumper to recover the firmware (see “System-board switches and jumpers” on page 38).</li> <li>b. (Trained service technician only) replace the system board.</li> </ol> </li> </ol>

## Server power features

When the server is connected to a power source but is not turned on, the operating system does not run, and all core logic except for the service processor (the integrated management module) is shut down; however, the server can respond to requests from the service processor, such as a remote request to turn on the server.

The power-on LED flashes to indicate that the server is connected to a power source but is not turned on.

### Turning on the server

Use this information to turn on the server.

Approximately 5 seconds after the server is connected to power, one or more fans might start running to provide cooling while the server is connected to power and the power-on button LED will blink quickly. Approximately 20 to 40 seconds after the server is connected to power, the power-control button becomes active (the power-on LED will blink slowly), and one or more fans might start running to provide cooling while the server is connected to power. You can turn on the server by pressing the power-control button.

The server can also be turned on in any of the following ways:

- If a power failure occurs while the server is turned on, the server will restart automatically when power is restored.
- If your operating system supports the Wake on LAN feature, the Wake on LAN feature can turn on the server.

**Note:** When 4 GB or more of memory (physical or logical) is installed, some memory is reserved for various system resources and is unavailable to the operating system. The amount of memory that is reserved for system resources depends on the operating system, the configuration of the server, and the configured PCI options.

### Turning off the server

Use this information to turn off the server.

When you turn off the server and leave it connected to power, the server can respond to requests from the service processor, such as a remote request to turn on the server. While the server remains connected to power, one or more fans might continue to run. To remove all power from the server, you must disconnect it from the power source.

Some operating systems require an orderly shutdown before you turn off the server. See your operating-system documentation for information about shutting down the operating system.

#### Statement 5



**CAUTION:**

The power control button on the device and the power switch on the power supply do not turn off the electrical current supplied to the device. The device also might have more than one power cord. To remove all electrical current from the device, ensure that all power cords are disconnected from the power source.

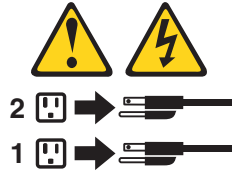

The server can be turned off in any of the following ways:

- You can turn off the server from the operating system, if your operating system supports this feature. After an orderly shutdown of the operating system, the server will turn off automatically.
- You can press the power-control button to start an orderly shutdown of the operating system and turn off the server, if your operating system supports this feature.
- If the operating system stops functioning, you can press and hold the power-control button for more than 4 seconds to turn off the server.
- The server can be turned off by Wake on LAN feature with the following limitation:
  - To install any PCI adapter, the power cords must be removed from the power source before you remove the PCI Express riser assembly and the PCI-X riser assembly. Otherwise, this will cause the active power management event signal to become disabled by the system board logic and Wake on LAN might not work. However, after the server is powered-on locally, the active power management event signal will be enabled by the system board logic.
- The integrated management module (IMM) can turn off the server as an automatic response to a critical system failure.

---

## Chapter 2. Installing optional devices

This section provides detailed instructions for installing optional hardware devices in the server.

---

### Instructions for IBM Business Partners

In addition to the instructions in this section for installing optional hardware devices, updating firmware and device drivers, and completing the installation, IBM Business Partners must also complete the following steps.

1. After you have confirmed that the server starts correctly and recognizes the newly installed devices and that no error LEDs are lit, run the Dynamic System Analysis (DSA) stress test.
2. Shut down and restart the server multiple times to ensure that the server is correctly configured and functions correctly with the newly installed devices.
3. Save the DSA log as a file and send it to IBM. For information about transferring data and logs, see "How to send DSA data to IBM."
4. To ship the server, repackage it in the original undamaged packing material and observe IBM procedures for shipping.

Support information for IBM Business Partners is available at <http://www.ibm.com/partnerworld/>.

---

### How to send DSA data to IBM

Use the IBM Enhanced Customer Data Repository to send diagnostic data to IBM.

Before you send diagnostic data to IBM, read the terms of use at <http://www.ibm.com/de/support/ecurep/terms.html>.

You can use any of the following methods to send diagnostic data to IBM:

- **Standard upload:** [http://www.ibm.com/de/support/ecurep/send\\_http.html](http://www.ibm.com/de/support/ecurep/send_http.html)
- **Standard upload with the system serial number:** [http://www.ecurep.ibm.com/app/upload\\_hw](http://www.ecurep.ibm.com/app/upload_hw)
- **Secure upload:** [http://www.ibm.com/de/support/ecurep/send\\_http.html#secure](http://www.ibm.com/de/support/ecurep/send_http.html#secure)
- **Secure upload with the system serial number:** [https://www.ecurep.ibm.com/app/upload\\_hw](https://www.ecurep.ibm.com/app/upload_hw)

## Server components

The following illustration shows the major components in the server.

The illustrations in this document might differ slightly from your hardware.

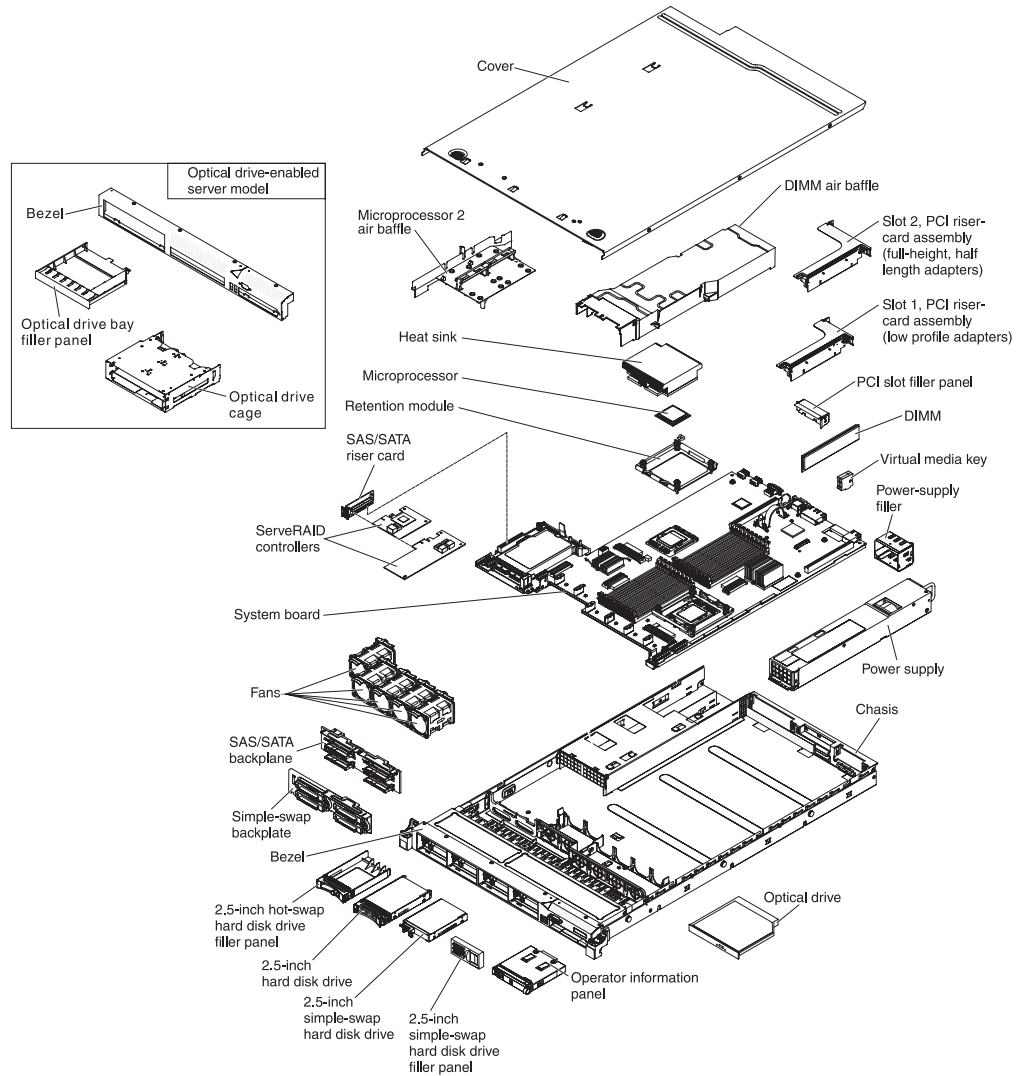

Figure 14. Server components

## System-board internal connectors

The following illustration shows the internal connectors on the system board.

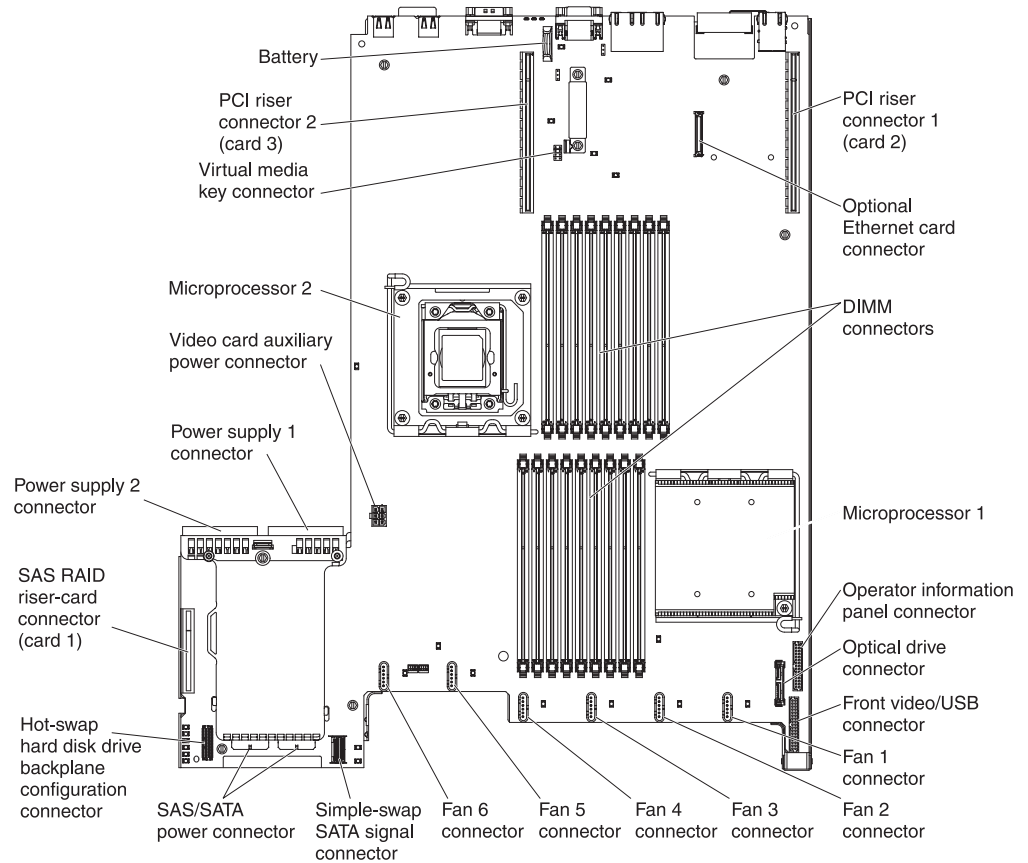

Figure 15. System-board internal connectors

## System-board external connectors

The following illustration shows the external connectors on the system board.

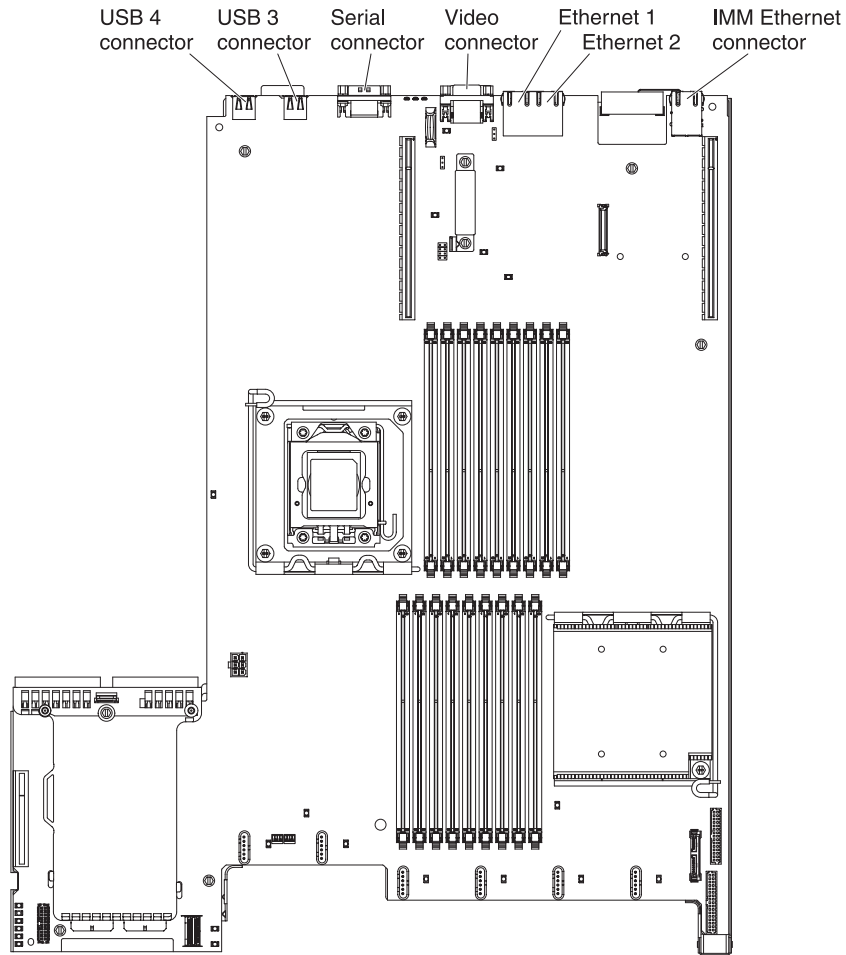

Figure 16. System-board external connectors

## System-board switches and jumpers

The following illustration shows the location and description of the switches and jumpers.

**Note:** If there is a clear protective sticker on the top of the switch blocks, you must remove and discard it to access the switches.

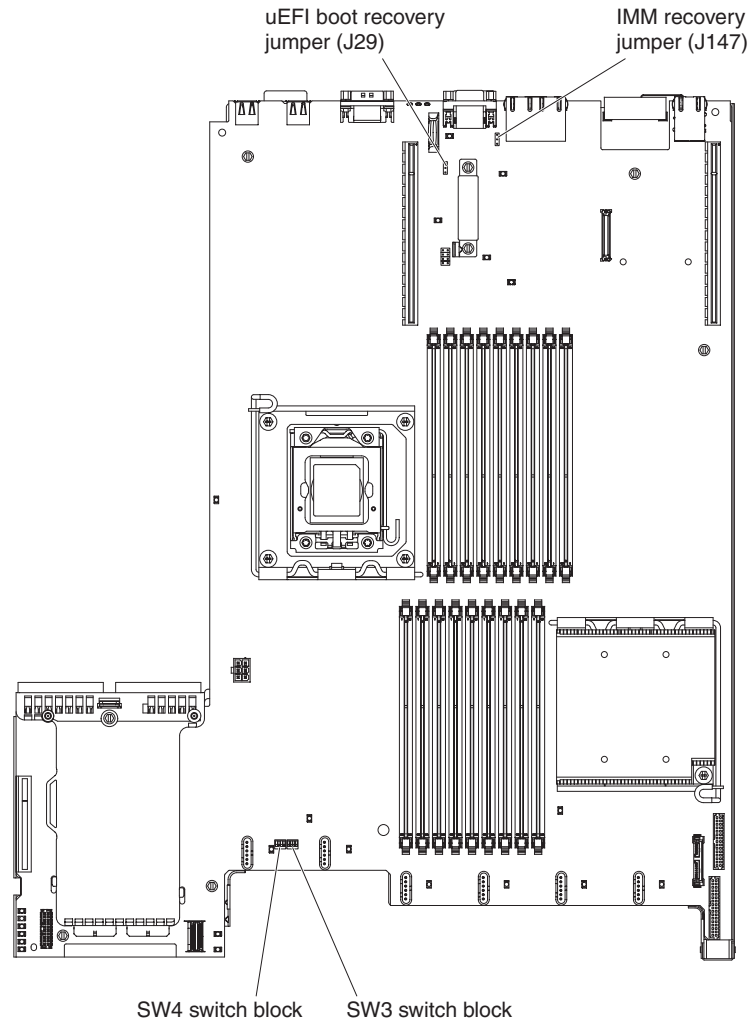

Figure 17. System-board switches and jumpers

Table 6. System board jumpers

Jumper number	Jumper name	Jumper setting
J29	UEFI boot recovery jumper	<ul style="list-style-type: none"> <li>• Pins 1 and 2: Normal (default) Loads the primary server firmware ROM page.</li> <li>• Pins 2 and 3: Loads the secondary (backup) server firmware ROM page.</li> </ul>
J147	IMM recovery jumper	<ul style="list-style-type: none"> <li>• Pins 1 and 2: Normal (default) Loads the primary IMM firmware ROM page.</li> <li>• Pins 2 and 3: Loads the secondary (backup) IMM firmware ROM page.</li> </ul>

Table 6. System board jumpers (continued)

Jumper number	Jumper name	Jumper setting
<b>Table notes:</b>		
1. If no jumper is present, the server responds as if the pins are set to 1 and 2.		
2. Changing the position of the UEFI boot recovery jumper (J29) from pins 1 and 2 to pins 2 and 3 before the server is turned on alters which flash ROM page is loaded. Do not change the jumper pin position after the server is turned on. This can cause an unpredictable problem.		

The following table describes the functions of the SW3 switch block on the system board.

Table 7. System board SW3 switch block definition

Switch number	Default position	Description
1	Off	Clear CMOS memory. When this switch is toggled to On, it clears the data in CMOS memory.
2	Off	Trust Platform Module (TPM) physical presence. Turning this switch to the on position indicates a physical presence to the TPM.
3	Off	Reserved.
4	Off	Reserved.

The following table describes the functions of the SW4 switch block on the system board.

Table 8. System board SW4 switch block definition

Switch number	Default position	Description
1	Off	Power-on password override. Changing the position of this switch bypasses the power-on password check the next time the server is turned on and starts the Setup utility so that you can change or delete the power-on password. You do not have to move the switch back to the default position after the power-on password is overridden.  Changing the position of this switch does not affect the administrator password check if an administrator password is set.  See "Passwords" on page 116 for additional information about passwords.

Table 8. System board SW4 switch block definition (continued)

Switch number	Default position	Description
2	Off	When you toggle this switch On and then Off, you force a power-on, which overrides the power-on and power-off button on the server and they become nonfunctional.
3	Off	(Trained service technician only) Forced power permission. Changing the position of this switch overrides the IMM power-on checking process.
4	Off	Reserved.

**Important:**

1. Before you change any switch settings or move any jumpers, turn off the server; then, disconnect all power cords and external cables. Review the information in “Safety” on page v, “Installation guidelines” on page 43, “Handling static-sensitive devices” on page 46, and “Turning off the server” on page 33.
2. Any system-board switch or jumper blocks that are not shown in the illustrations in this document are reserved.

## System-board LEDs

The following illustration shows the light-emitting diodes (LEDs) on the system board.

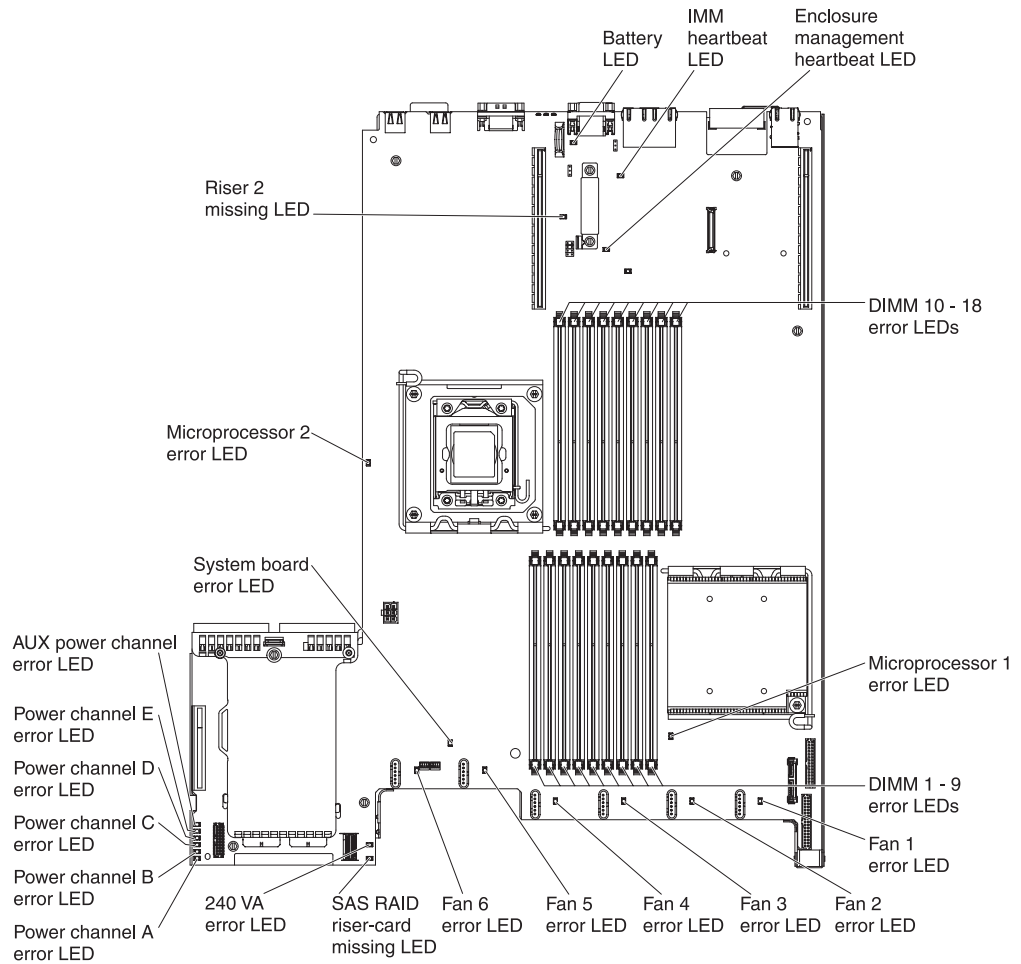

Figure 18. System-board LEDs

## System-board optional device connectors

The following illustration shows the connectors for user-installable options.

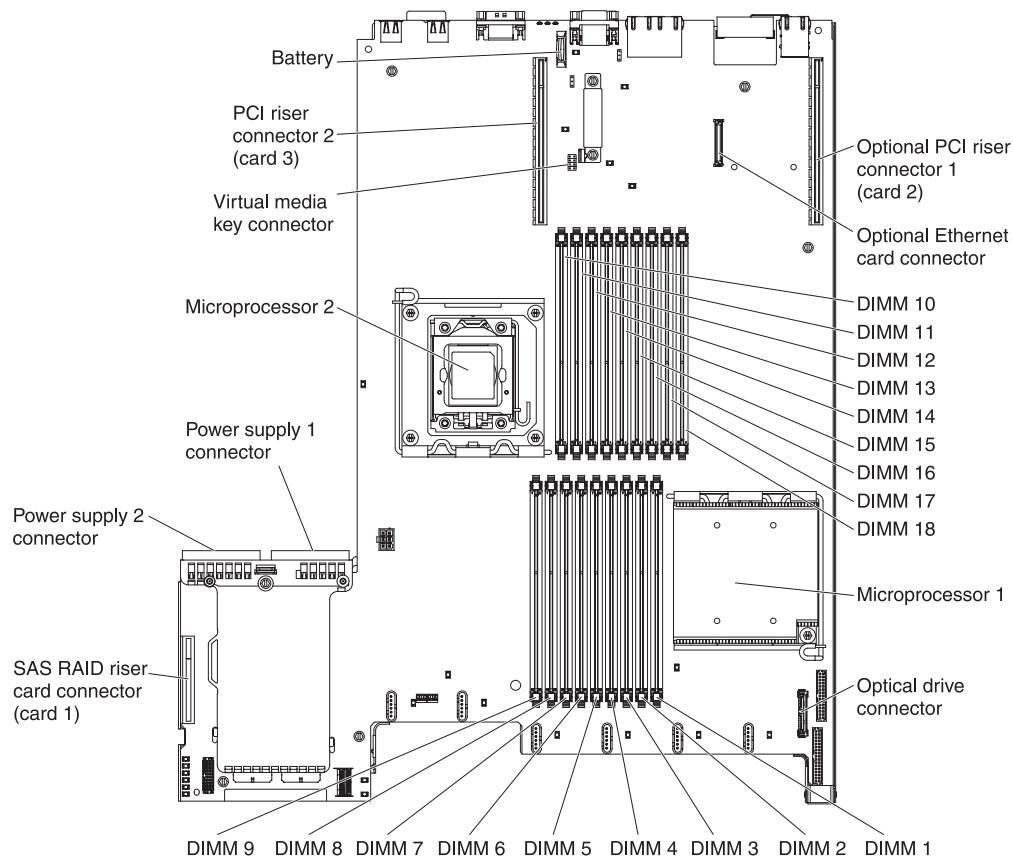

Figure 19. System-board optional device connectors

## Installation guidelines

Use this information for installation.

**Attention:** Static electricity that is released to internal server components when the server is powered-on might cause the system to halt, which might result in the loss of data. To avoid this potential problem, always use an electrostatic-discharge wrist strap or other grounding system when removing or installing a hot-swap device.

Before you install optional devices, read the following information:

- Read the safety information in “Safety” on page v, the guidelines in “Working inside the server with the power on” on page 45, and “Handling static-sensitive devices” on page 46. This information will help you work safely.
- Make sure that the devices that you are installing are supported. For a list of supported optional devices for the server, see <http://www.ibm.com/systems/info/x86servers/serverproven/compat/us/>.
- When you install your new server, take the opportunity to download and apply the most recent firmware updates. This step will help to ensure that any known issues are addressed and that your server is ready to function at maximum levels of performance. To download firmware updates for your server, go to <http://www.ibm.com/support/fixcentral/>.

**Important:** Some cluster solutions require specific code levels or coordinated code updates. If the device is part of a cluster solution, verify that the latest level of code is supported for the cluster solution before you update the code.

For additional information about tools for updating, managing, and deploying firmware, see the ToolsCenter for System x and BladeCenter at <http://publib.boulder.ibm.com/infocenter/toolsctr/v1r0/>.

- Before you install optional hardware, make sure that the server is working correctly. Start the server, and make sure that the operating system starts, if an operating system is installed, or that a 19990305 error code is displayed, indicating that an operating system was not found but the server is otherwise working correctly. If the server is not working correctly, see the *Problem Determination and Service Guide* on the IBM *System x Documentation* CD for diagnostic information.
- Observe good housekeeping in the area where you are working. Place removed covers and other parts in a safe place.
- If you must start the server while the server cover is removed, make sure that no one is near the server and that no tools or other objects have been left inside the server.
- Do not attempt to lift an object that you think is too heavy for you. If you have to lift a heavy object, observe the following precautions:
  - Make sure that you can stand safely without slipping.
  - Distribute the weight of the object equally between your feet.
  - Use a slow lifting force. Never move suddenly or twist when you lift a heavy object.
  - To avoid straining the muscles in your back, lift by standing or by pushing up with your leg muscles.
- Make sure that you have an adequate number of properly grounded electrical outlets for the server, monitor, and other devices.
- Back up all important data before you make changes to disk drives.
- Have a small flat-blade screwdriver, a small Phillips screwdriver, and a T8 torx screwdriver available.
- You do not have to turn off the server to install or replace hot-swap power supplies, hot-swap fans, or hot-plug Universal Serial Bus (USB) devices. However, you must turn off the server before you perform any steps that involve removing or installing adapter cables and you must disconnect the power source from the server before you perform any steps that involve removing or installing a riser card.
- Blue on a component indicates touch points, where you can grip the component to remove it from or install it in the server, open or close a latch, and so on.
- Orange on a component or an orange label on or near a component indicates that the component can be hot-swapped, which means that if the server and operating system support hot-swap capability, you can remove or install the component while the server is running. (Orange can also indicate touch points on hot-swap components.) See the instructions for removing or installing a specific hot-swap component for any additional procedures that you might have to perform before you remove or install the component.
- When you are finished working on the server, reinstall all safety shields, guards, labels, and ground wires.

## System reliability guidelines

To help ensure proper system cooling and system reliability, make sure that the following requirements are met.

To help ensure proper system cooling and system reliability, make sure that the following requirements are met:

- Each of the drive bays has a drive or a filler panel and electromagnetic compatibility (EMC) shield installed in it.
- If the server has redundant power, each of the power-supply bays has a power supply installed in it.
- There is adequate space around the server to allow the server cooling system to work properly. Leave approximately 50 mm (2.0 in.) of open space around the front and rear of the server. Do not place objects in front of the fans. For proper cooling and airflow, replace the server cover before you turn on the server.
- You have followed the cabling instructions that come with optional adapters.
- You have replaced a failed fan within 48 hours.
- You have replaced a hot-swap fan within 30 seconds of removal.
- You have replaced a hot-swap drive within 2 minutes of removal.
- You do not operate the server without the air baffle installed. Operating the server without the air baffle might cause the microprocessor to overheat.
- Microprocessor socket 2 always contains either a microprocessor baffle or a microprocessor and heat sink.
- You have installed the sixth fan when you installed the second microprocessor option.

## Working inside the server with the power on

Use this information when working inside the server with the power on.

**Attention:** Static electricity that is released to internal server components when the server is powered-on might cause the server to halt, which might result in the loss of data. To avoid this potential problem, always use an electrostatic-discharge wrist strap or other grounding system when you work inside the server with the power on.

The server supports hot-plug, hot-add, and hot-swap devices and is designed to operate safely while it is turned on and the server cover is removed. Follow these guidelines when you work inside a server that is turned on:

- Avoid wearing loose-fitting clothing on your forearms. Button long-sleeved shirts before working inside the server; do not wear cuff links while you are working inside the server.
- Do not allow your necktie or scarf to hang inside the server.
- Remove jewelry, such as bracelets, necklaces, rings, and loose-fitting wrist watches.
- Remove items from your shirt pocket, such as pens and pencils, that could fall into the server as you lean over it.
- Avoid dropping any metallic objects, such as paper clips, hairpins, and screws, into the server.

## Handling static-sensitive devices

Use this information to handle static-sensitive devices.

**Attention:** Static electricity can damage the server and other electronic devices. To avoid damage, keep static-sensitive devices in their static-protective packages until you are ready to install them.

To reduce the possibility of damage from electrostatic discharge, observe the following precautions:

- Limit your movement. Movement can cause static electricity to build up around you.
- The use of a grounding system is recommended. For example, wear an electrostatic-discharge wrist strap, if one is available. Always use an electrostatic-discharge wrist strap or other grounding system when working inside the server with the power on.
- Handle the device carefully, holding it by its edges or its frame.
- Do not touch solder joints, pins, or exposed circuitry.
- Do not leave the device where others can handle and damage it.
- While the device is still in its static-protective package, touch it to an unpainted metal surface on the outside of the server for at least 2 seconds. This drains static electricity from the package and from your body.
- Remove the device from its package and install it directly into the server without setting down the device. If it is necessary to set down the device, put it back into its static-protective package. Do not place the device on the server cover or on a metal surface.
- Take additional care when handling devices during cold weather. Heating reduces indoor humidity and increases static electricity.

---

## Internal cable routing and connectors

Use this information to view the cable connection and connectors.

The following illustration shows the internal routing and connectors for the two SAS signal cables (in server models with eight drive bays).

**Notes:**

1. To connect the SAS signal cables, make sure that you first connect the signal cable, and then the power cable and configuration cable.
2. To disconnect the SAS signal cables, make sure that you first disconnect the power cable, and then the signal cable and configuration cable.

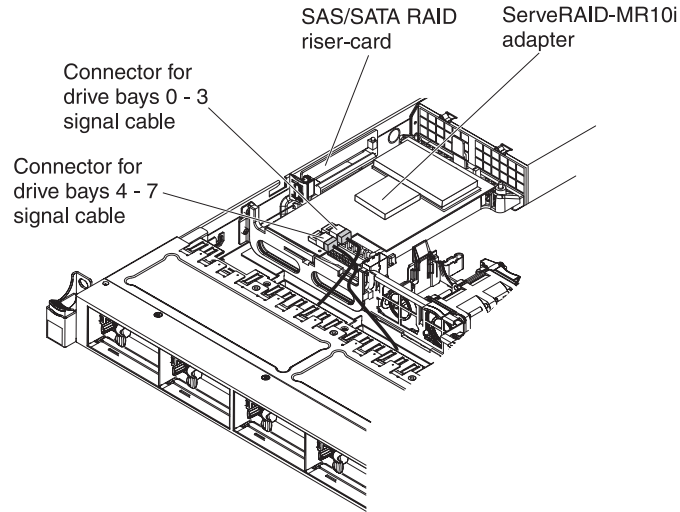

Figure 20. ServeRAID adapter cable connection

The following illustration shows the internal routing and connector for the optional optical drive cable.

**Attention:** To disconnect the optional optical drive cable, you must first press the connector release tab, and then disconnect the cable from the connector on the system board. Do not disconnect the cable by using excessive force.

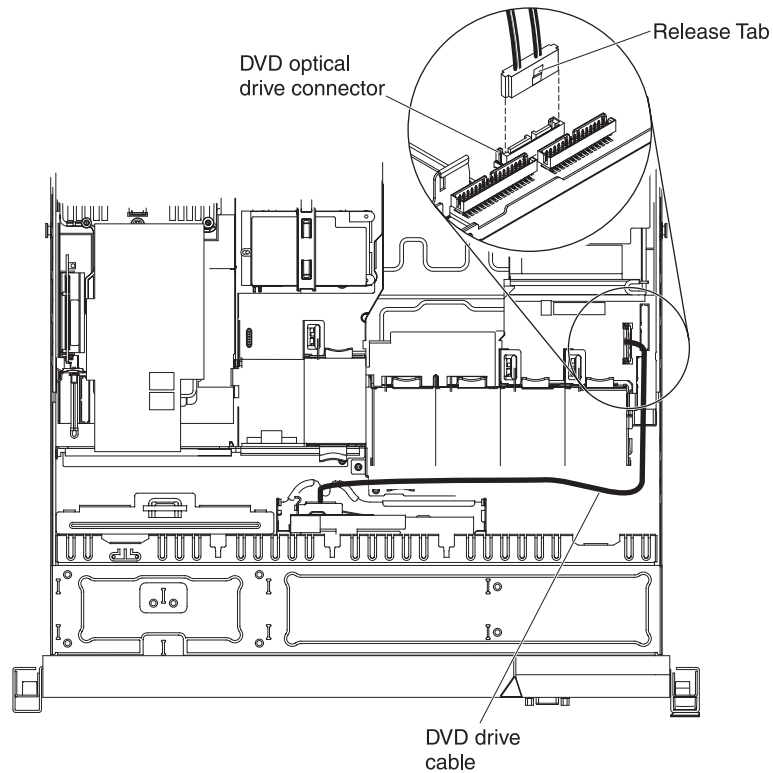
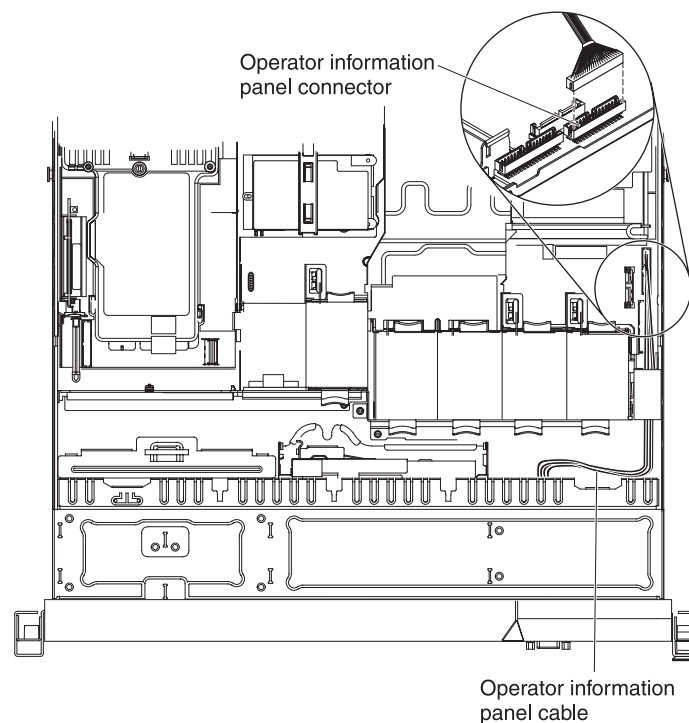

Figure 21. DVD drive cable connection

The following illustration shows the internal routing and connector for the operator information panel cable. The following notes describe additional information you must consider when you install or remove the operator information panel cable:

- You may remove the optional optical drive cable to obtain more room before you install or remove the operator information panel cable.
- To remove the operator information panel cable, slightly press the cable toward the chassis; then, pull to remove the cable from the connector on the system board. Pulling the cable out of the connector by excessive force might cause damage to the cable or connector.
- To connect the operator information panel cable on the system board, press evenly on the cable. Pressing on one side of the cable might cause damage to the cable or connector.

**Attention:** Failing to install or remove the cable with care may damage the connectors on the system board. Any damage to the connectors may require replacing the system board.



*Figure 22. Operator information panel cable connection*

The following illustration shows the internal routing and connector for the USB/video cable. The following notes describes other information you must consider when you install or remove the USB/video cable:

- You may remove the optional optical drive cable to obtain more room before you install or remove the operator information panel cable.
- The USB/video cable is routed under the video cable and then both the USB and video cables are routed under the cable retention tab and the top cover latch receptacle.

- To remove the USB/video cable, slightly press the cable toward the chassis; then, pull to remove the cable from the connector on the system board. Pulling the cable out of the connector by excessive force might cause damage to the cable or connector.
- To connect the USB/video cable on the system board, press evenly on the cable. Pressing on one side of the cable might cause damage to the cable or connector.

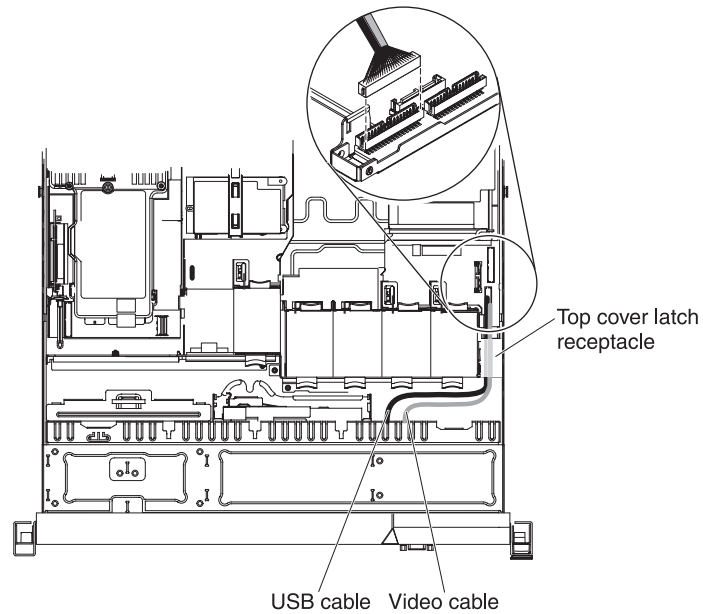
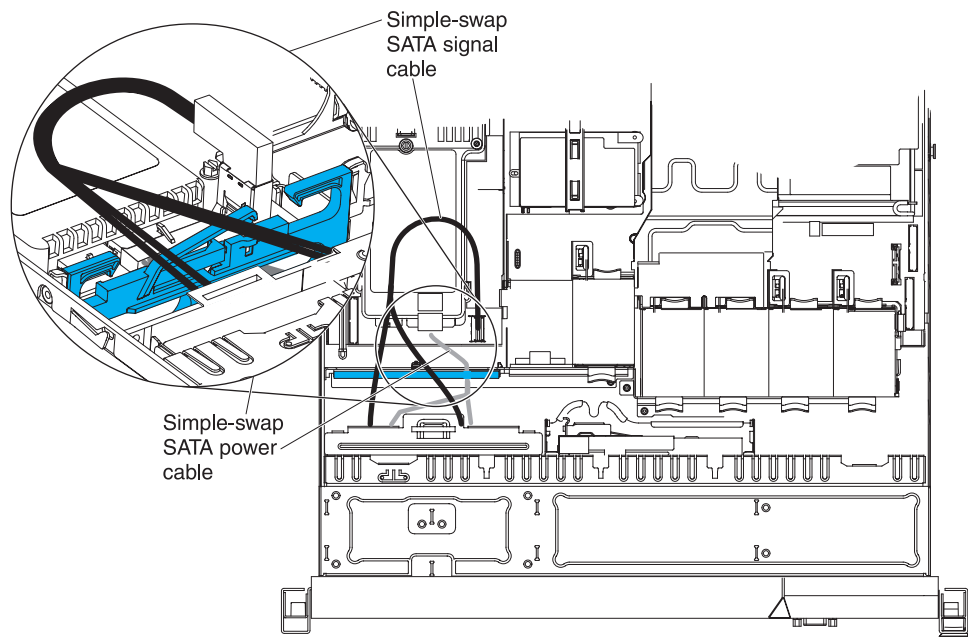

Figure 23. USB/video cable connection

The following illustration shows the internal routing for the SATA power cable and signal cable.



*Figure 24. Simple-swap backplate assembly cable connection*

The following illustration shows the internal routing for the SATA power cable, the SATA signal cable, and the configuration cable.

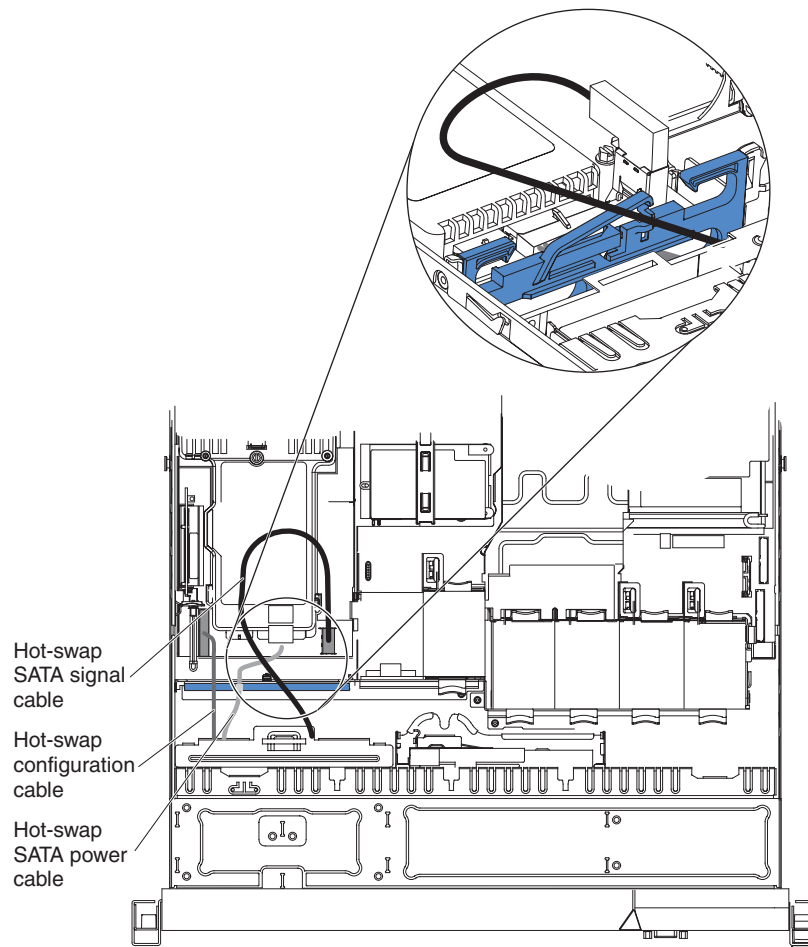

Figure 25. Hot-swap backplane cable connection

## Removing the cover

Use this information to remove the cover.

### About this task

To remove the server cover, complete the following steps:

#### Procedure

1. Read the safety information that begins on “Safety” on page v and “Installation guidelines” on page 43.
2. Turn off the server and peripheral devices and disconnect the power cords and all external cables, if necessary.

**Note:** When you disconnect the power source from the server, you lose the ability to view the LEDs because the LEDs are not lit when the power source is removed. Before you disconnect the power source, make a note of which LEDs are lit, including the LEDs that are lit on the operation information panel, on the light path diagnostics panel, and LEDs inside the server on the system board.

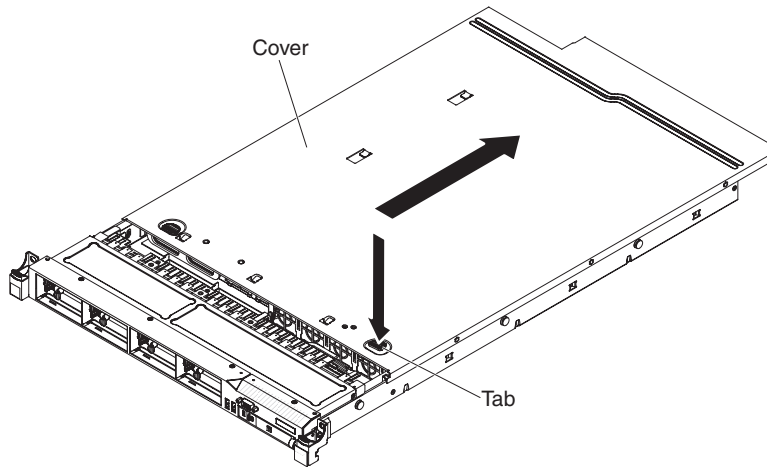

Figure 26. Cover removal

3. If the server has been installed in a rack, slide the server out from the rack enclosure.
4. Press down firmly on the blue tab on the top (near the front of the server) of the cover and slide the cover toward the rear of the server until the cover has disengaged from the chassis.
5. Lift the server cover off the server and set it aside.

**Attention:** For proper cooling and airflow, replace the server cover before you turn on the server.

---

## Removing the DIMM air baffle

Use this information to remove the DIMM air baffle.

### About this task

To remove the DIMM air baffle, complete the following steps:

### Procedure

1. Read the safety information that begins on “Safety” on page v and “Installation guidelines” on page 43.
2. Turn off the server and peripheral devices and disconnect all power cords and external cables if necessary.
3. Grasp the DIMM air baffle and lift the baffle up, making sure that the pin comes out of the pin hole on the system board to the left of DIMM connector 8.

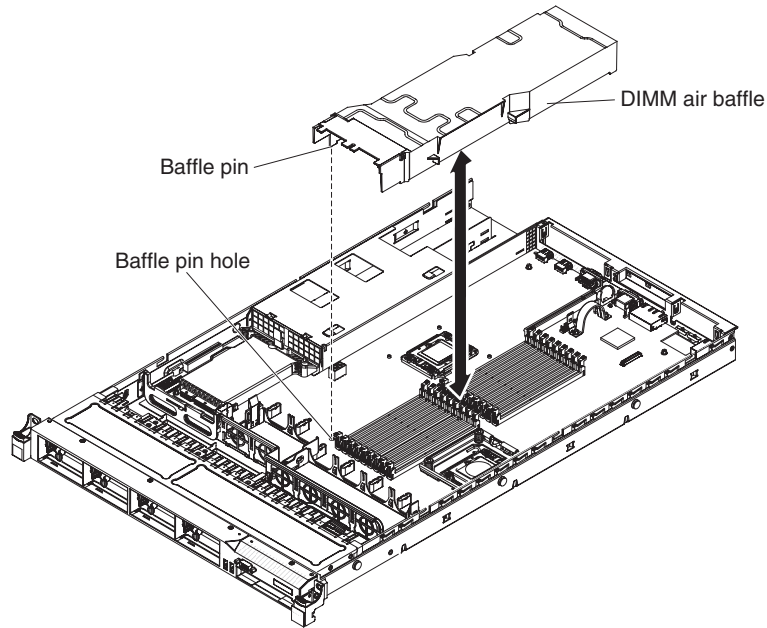

Figure 27. DIMM air baffle removal

4. Remove it from the server and set it aside.

**Attention:** For proper cooling and airflow, replace the air baffle before you turn on the server. Operating the server with an air baffle removed might damage server components.

---

## Removing the microprocessor 2 air baffle

Use this information to remove the microprocessor 2 air baffle.

### About this task

To remove the microprocessor 2 air baffle, complete the following steps:

### Procedure

1. Read the safety information that begins on “Safety” on page v and “Installation guidelines” on page 43.
2. Turn off the server and peripheral devices and disconnect the power cords and all external cables.
3. Lift the air baffle up, making sure that the tab comes out of the hole on the side of the power-supply cage; then, remove the air baffle from the server and set it aside.

**Attention:** For proper cooling and airflow, replace the air baffle before you turn on the server. Operating the server with the air baffle removed might damage server components.

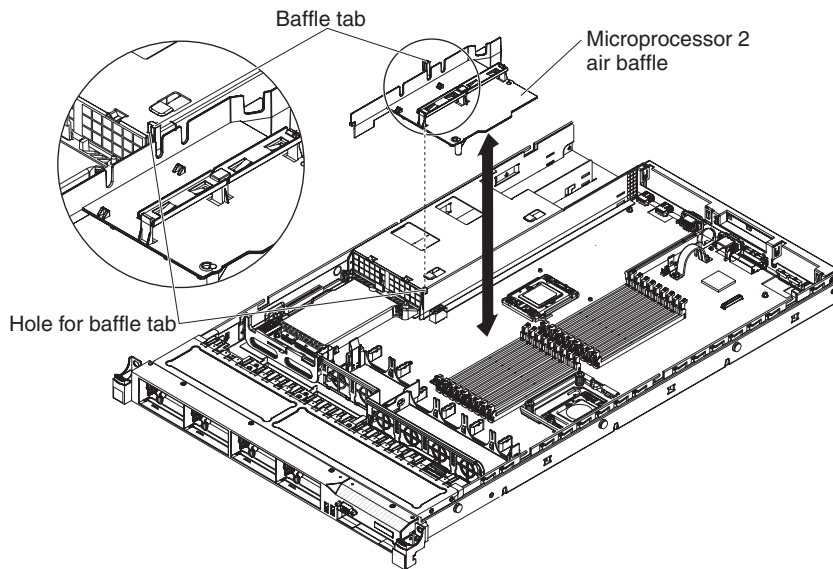

Figure 28. Microprocessor 2 air baffle removal

## Installing a memory module

The following notes describe the types of DIMMs that the server supports and other information that you must consider when you install DIMMs.

- When you install or remove DIMMs, the server configuration information changes. When you restart the server, the system displays a message that indicates that the memory configuration has changed.
- The server supports only industry-standard double-data-rate 3 (DDR3), 800, 1066, or 1333 MHz, PC3-10600R-999, registered or unbuffered, synchronous dynamic random-access memory (SDRAM) dual inline memory modules (DIMMs) with error correcting code (ECC). See <http://www.ibm.com/supportportal/> for a list of supported memory modules for the server.
  - The specifications of a DDR3 DIMM are on a label on the DIMM, in the following format.

*ggg eRxff-PC3-wwwwm-aa-bb-cc*

where:

- *ggg* is the total capacity of the DIMM (for example, 1GB, 2GB, or 4GB)
- *e* is the number of ranks
  - 1 = single-rank
  - 2 = dual-rank
  - 4 = quad-rank
- *ff* is the device organization (bit width)
  - 4 = x4 organization (4 DQ lines per SDRAM)
  - 8 = x8 organization
  - 16 = x16 organization
- *wwww* is the DIMM bandwidth, in MBps
  - 6400 = 6.40 GBps (PC3-800 SDRAMs, 8-byte primary data bus)
  - 8500 = 8.53 GBps (PC3-1066 SDRAMs, 8-byte primary data bus)
  - 10600 = 10.66 GBps (PC3-1333 SDRAMs, 8-byte primary data bus)
  - 12800 = 12.80 GBps (PC3-1600 SDRAMs, 8-byte primary data bus)

- *m* is the DIMM type
  - E = Unbuffered DIMM (UDIMM) with ECC (x72-bit module data bus)
  - R = Registered DIMM (RDIMM)
  - U = Unbuffered DIMM with no ECC (x64-bit primary data bus)
- *aa* is the CAS latency, in clocks at maximum operating frequency
- *bb* is the JEDEC SPD Revision Encoding and Additions level
- *cc* is the reference design file for the design of the DIMM
- *d* is the revision number of the reference design of the DIMM

**Note:** To determine the type of a DIMM, see the label on the DIMM. The information on the label is in the format *xxxxx nRxxx PC3-xxxxx-xx-xx-xxx*. The numeral in the sixth numerical position indicates whether the DIMM is single-rank (n=1), dual-rank (n=2), or quad-rank (n=4).

- The following rules apply to DDR3 DIMM speed as it relates to the number of DIMMs in a channel:
  - When you install 1 DIMM per channel, the memory runs at 1333 MHz
  - When you install 2 DIMMs per channel, the memory runs at 1066 MHz
  - When you install 3 DIMMs per channel, the memory runs at 800 MHz
  - All channels in a server run at the fastest common frequency
  - Do not install registered and unbuffered DIMMs in the same server
- The maximum memory speed is determined by the combination of the microprocessor, DIMM speed, and the number of DIMMs installed in each channel.
- In two-DIMM-per-channel configuration, a server with an Intel Xeon X5600 series microprocessor automatically operates with a maximum memory speed of up to 1333 MHz when one of the following conditions is met:
  - Two 1.5 V single-rank or dual-rank RDIMMs are installed in the same channel. In the Setup utility, **Memory speed** is set to **Max performance** mode
  - Two 1.35 V single-rank or dual-rank RDIMMs are installed in the same channel. In the Setup utility, **Memory speed** is set to **Max performance** and **LV-DIMM power** is set to **Enhance performance** mode. The 1.35 V RDIMMs will function at 1.5 V
- The server supports a maximum of 18 single-rank or dual-rank RDIMMs. The server supports up to 12 single-rank or dual-rank UDIMMs or quad-rank RDIMMs.
- The server supports three single-rank or dual-rank DIMMs per channel. The server supports a maximum of two quad-rank RDIMMs per channel. The following table shows an example of the maximum amount of memory that you can install using ranked DIMMs:

*Table 9. Maximum memory installation using ranked DIMMs*

Number of DIMMs	DIMM type	DIMM size	Total memory
12	Single-rank UDIMMs	2 GB	24 GB
12	Dual-rank UDIMMs	4 GB	48 GB
18	Single-rank RDIMMs	2 GB	36 GB
18	Dual-rank RDIMMs	2 GB	36 GB
18	Dual-rank RDIMMs	4 GB	72 GB
18	Dual-rank RDIMMs	8 GB	144 GB
12	Quad-rank RDIMMs	16 GB	192 GB

Table 9. Maximum memory installation using ranked DIMMs (continued)

Number of DIMMs	DIMM type	DIMM size	Total memory
18	Dual-rank RDIMMs	16 GB	288 GB

- The RDIMM options that are available for the server are 2 GB, 4 GB, 8 GB, and 16 GB. The server supports a minimum of 2 GB and a maximum of 288 GB of system memory using RDIMMs.

**For 32-bit operating systems only:** Some memory is reserved for various system resources and is unavailable to the operating system. The amount of memory that is reserved for system resources depends on the operating system, the configuration of the server, and the configured PCI devices.

- The UDIMM options that are available for the server are 2 GB and 4 GB. The server supports a minimum of 2 GB and a maximum of 48 GB of system memory using UDIMMs.

**Note:** The amount of usable memory is reduced depending on the system configuration. A certain amount of memory must be reserved for system resources. To view the total amount of installed memory and the amount of configured memory, run the Setup utility. For additional information, see Chapter 3, “Configuring the server,” on page 111.

- A minimum of one DIMM must be installed for each microprocessor. For example, you must install a minimum of two DIMMs if the server has two microprocessors installed. However, to improve system performance, install a minimum of three DIMMs for each microprocessor.
- DIMMs in the same channel must be the same type (RDIMM or UDIMM) to ensure that the server will operate correctly.
- When you install one quad-rank RDIMM in a channel, install it in the DIMM connector furthest away from the microprocessor.
- Do not install one quad-rank RDIMM in one channel and three RDIMMs in another channel.

The following illustration shows the location of the DIMM connectors on the system board.

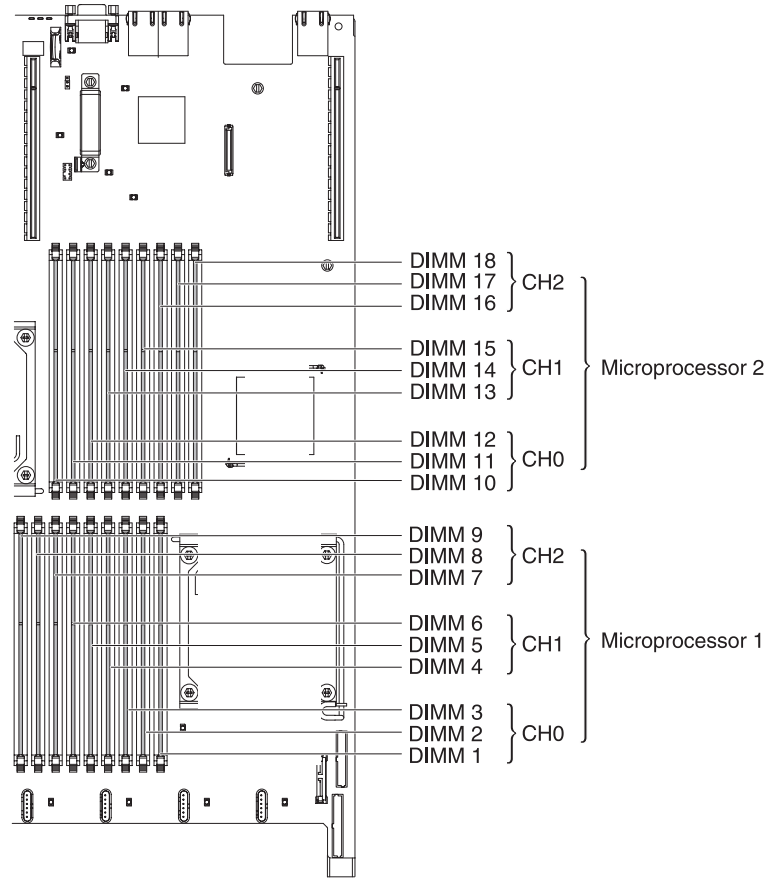

Figure 29. DIMM connectors location

## DIMM installation sequence

Depending on the server model, the server may come with a minimum of one 2 GB or 4 GB DIMM installed in slot 3.

When you install additional DIMMs, install them in the order shown in the following table to optimize system performance. In non-mirroring mode, all three channels on the memory interface for each microprocessor can be populated in any order and have no matching requirements.

Table 10. Non-mirroring (normal) mode DIMM installation sequence

Installed microprocessor	DIMM connector population sequence
Microprocessor socket 1	3, 6, 9, 2, 5, 8, 1, 4, 7
Microprocessor socket 2	12, 15, 18, 11, 14, 17, 10, 13, 16

## Memory mirroring

Memory-mirroring mode replicates and stores data on two pairs of DIMMs within two channels simultaneously. If a failure occurs, the memory controller switches from the primary pair of memory DIMMs to the backup pair of DIMMs.

To enable memory mirroring through the Setup utility, select **System Settings > Memory**. For more information, see “Using the Setup utility” on page 112. When you use the memory mirroring feature, consider the following information:

- When you use memory mirroring, you must install a pair of DIMMs at a time. One DIMM must be in channel 0, and the mirroring DIMM must be in the same slot in channel 1. The two DIMMs in each pair must be identical in size, type, and rank (single or dual), and organization, but not in speed. The channels run at the speed of the slowest DIMM in any of the channels.
- Channel 2, DIMM connectors 7, 8, 9, 16, 17, and 18 are not used in memory-mirroring mode.
- The maximum available memory is reduced to half of the installed memory when memory mirroring is enabled. For example, if you install 64 GB of memory using RDIMMs, only 32 GB of addressable memory is available when you use memory mirroring.

The following diagram shows the memory channel interface layout with the DIMM installation sequence for mirroring mode. The numbers within the boxes indicate the DIMM population sequence in pairs within the channels, and the numbers next to the boxes indicate the DIMM connectors within the channels. For example, the following illustration shows the first pair of DIMMs (indicated by ones (1) inside the boxes) should be installed in DIMM connector 1 on channel 0 and DIMM connector 2 on channel 1. DIMM connectors 3, 6, 9, 12, 15, and 18 on channel 2 are not used in memory-mirroring mode.

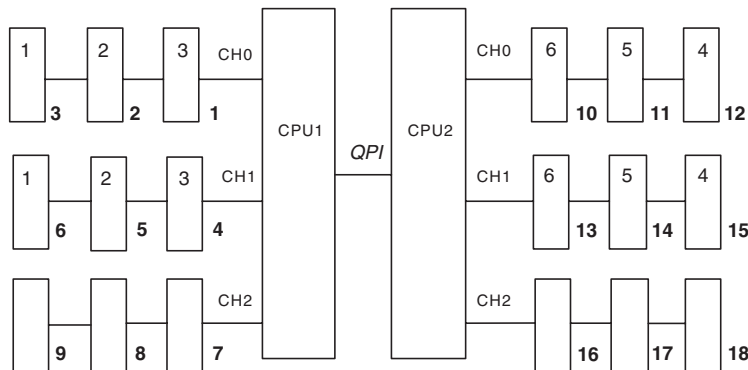

Figure 30. Memory channel interface layout

The following table lists the DIMM connectors on each memory channel.

Table 11. Connectors on each memory channel

Memory channel	DIMM connector
Channel 0	1, 2, 3, 10, 11, 12
Channel 1	4, 5, 6, 13, 14, 15
Channel 2	7, 8, 9, 16, 17, 18

The following illustration shows the memory connector layout that is associated with each microprocessor. For example, DIMM connectors 10, 11, 12, 13, 14, 15, 16, 17, and 18 (DIMM connectors are shown underneath the boxes) are associated with microprocessor 2 (CPU2) and DIMM connectors 1, 2, 3, 4, 5, 6, 7, 8, and 9 are associated with microprocessor 1 (CPU1). The numbers within the boxes indicate the installation sequence of the DIMM pairs. For example, the first DIMM pair (indicated within the boxes by ones (1)) should be installed in DIMM connectors 1 and 2, which is associated with microprocessor 1 (CPU1).

**Note:** You can install DIMMs for microprocessor 2 as soon as you install microprocessor 2; you do not have to wait until all of the DIMM slots for microprocessor 1 are filled.

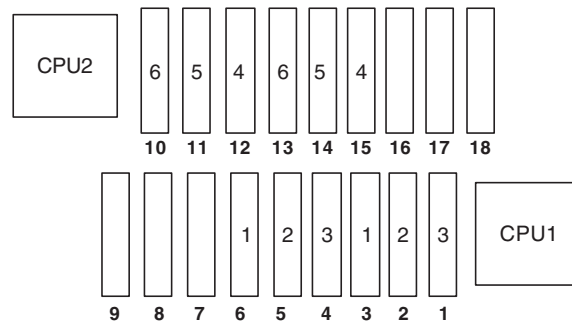

Figure 31. Memory connectors associated with each microprocessor for memory mirroring

The following table shows the installation sequence for installing DIMMs in memory-mirroring mode:

Table 12. Memory mirroring mode DIMM population sequence

Number of DIMMs	Number of installed microprocessor	DIMM connector
First pair of DIMMs	1	3, 6
Second pair of DIMMs	1	2, 5
Third pair of DIMMs	1	1, 4
Fourth pair of DIMMs	2	12, 15
Fifth pair of DIMMs	2	11, 14
Sixth pair of DIMMs	2	10, 13
<b>Table note:</b> DIMM connectors 7, 8, 9, 16, 17, and 18 are not used in memory-mirroring mode.		

## Online-spare memory

The memory online-spare feature disables the failed memory from the system configuration and activates an online-spare DIMM to replace the failed active DIMM.

You can enable either online-spare memory or memory mirroring in the Setup utility (see “Using the Setup utility” on page 112). When you use the memory online-spare feature, consider the following information:

- The memory online-spare feature is supported on server models with an Intel Xeon™ 5600 series microprocessor.
- When you enable the memory online-spare feature, you must install three DIMMs per microprocessor at a time. The first DIMM must be in channel 0, the second DIMM in channel 1, and the third DIMM in channel 2. The DIMMs must be identical in size, type, rank, and organization, but not in speed. The channels run at the speed of the slowest DIMM in any of the channels.
- The maximum available memory is reduced to 2/3 of the installed memory when memory online-spare mode is enabled. For example, if you install 72 GB of memory using RDIMMs, only 48 GB of addressable memory is available when you use memory online-spare.

The following table shows the installation sequence for installing DIMMs for each microprocessor in memory online-spare mode:

*Table 13. Memory online-spare mode DIMM population sequence*

Installed Microprocessor	DIMM connector
Microprocessor 1	3, 6, 9
	3, 6, 9, 2, 5, 8
	3, 6, 9, 2, 5, 8, 1, 4, 7
Microprocessor 2	12, 15, 18,
	12, 15, 18, 11, 14, 17,
	12, 15, 18, 11, 14, 17, 10, 13, 16

## Installing a DIMM

Use this information to install a DIMM.

### About this task

To install a DIMM, complete the following steps:

### Procedure

1. Read the safety information that begins on “Safety” on page v and “Installation guidelines” on page 43.
2. Turn off the server and peripheral devices and disconnect the power cords and all external cables, if necessary.
3. Remove the cover (see “Removing the cover” on page 51).
4. Open the retaining clip on each end of the DIMM connector.

**Attention:** To avoid breaking the retaining clips or damaging the DIMM connectors, open and close the clips gently.

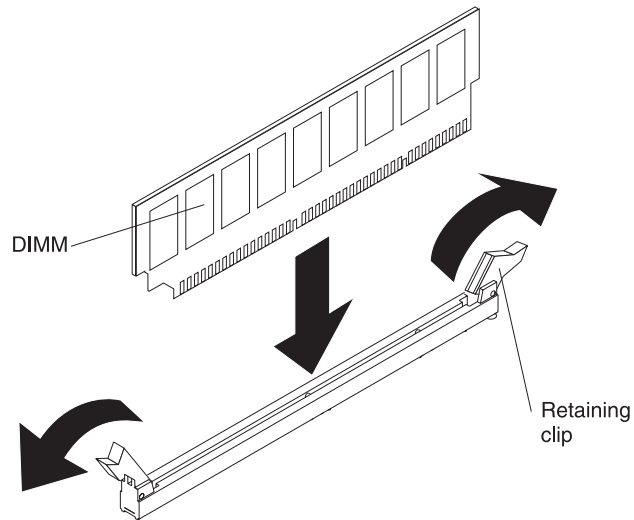

Figure 32. DIMM installation

5. Touch the static-protective package that contains the DIMM to any unpainted metal surface on the outside of the server. Then, remove the DIMM from the package.
6. Turn the DIMM so that the DIMM keys align correctly with the connector.
7. Insert the DIMM into the connector by aligning the edges of the DIMM with the slots at the ends of the DIMM connector (see “System-board optional device connectors” on page 42 for the locations of the DIMM connectors).
8. Firmly press the DIMM straight down into the connector by applying pressure on both ends of the DIMM simultaneously. The retaining clips snap into the locked position when the DIMM is firmly seated in the connector.

**Note:** If there is a gap between the DIMM and the retaining clips, the DIMM has not been correctly inserted; open the retaining clips, remove the DIMM, and then reinsert it.

## Results

If you have other devices to install or remove, do so now. Otherwise, go to “Completing the installation” on page 106.

---

## Installing drives

The following notes describe the type of drives that the server supports and other information that you must consider when you install a drive.

- Make sure that the devices that you are installing are supported. For a list of supported optional devices for the server, see <http://www.ibm.com/systems/info/x86servers/serverproven/compat/us/>.
- Locate the documentation that comes with the drive and follow those instructions in addition to the instructions in this chapter.
- Make sure that you have all the cables and other equipment that are specified in the documentation that comes with the drive.
- Select the bay in which you want to install the drive.
- The server supports one optional ultra-slim SATA optical drive.
- Check the instructions that come with the drive to determine whether you have to set any switches or jumpers on the drive. If you are installing a SAS or SATA hard disk drive, be sure to set the SAS or SATA ID for that device.
- The hot-swap server models support up to eight 2.5-inch hot-swap SAS or hot-swap SATA hard disk drives. The simple-swap server models support up to four 2.5-inch simple-swap SATA hard disk drives.
- The electromagnetic interference (EMI) integrity and cooling of the server are protected by having all bays and PCI and PCI Express slots covered or occupied. When you install a drive, PCI, or PCI Express adapter, save the EMC shield and filler panel from the bay or PCI adapter or PCI Express adapter slot cover in the event that you later remove the device.

### Installing a hot-swap hard disk drive

Use this information to install a hot-swap hard disk drive.

#### About this task

To install a 2.5-inch hot-swap SAS or SATA hard disk drive, complete the following steps.

**Note:** If you have only one hard disk drive, you must install it in the upper-left bay.

#### Procedure

1. Read the safety information that begins on “Safety” on page v and “Installation guidelines” on page 43.
2. Remove the filler panel from the empty drive bay.
3. Touch the static-protective package that contains the drive to any unpainted metal surface on the server; then, remove the drive from the package and place it on a static-protective surface.
4. Install the hard disk drive in the drive bay:
  - a. Make sure that the tray handle is in the open (unlocked) position.
  - b. Align the drive assembly with the guide rails in the bay.

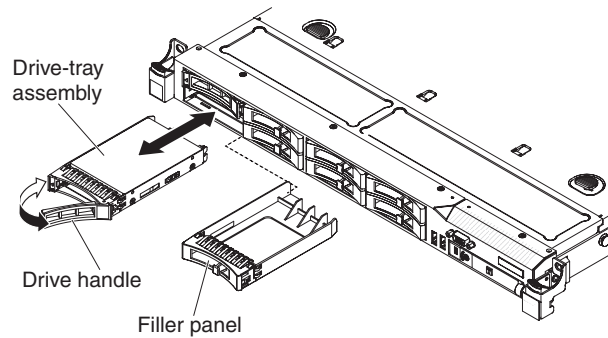

Figure 33. Hot-swap hard disk drive installation

- c. Gently push the drive assembly into the bay until the drive stops.
- d. Rotate the tray handle to the closed (locked) position.
- e. Check the hard disk drive status LED to verify that the hard disk drive is operating correctly. If the amber hard disk drive status LED for a drive is lit continuously, that drive is faulty and must be replaced. If the green hard disk drive activity LED is flashing, the drive is being accessed.

**Note:** If the server is configured for RAID operation using a ServeRAID adapter, you might have to reconfigure your disk arrays after you install hard disk drives. See the ServeRAID adapter documentation for additional information about RAID operation and complete instructions for using the ServeRAID adapter.

5. If you are installing additional hot-swap hard disk drives, do so now.

## Results

If you have other devices to install or remove, do so now. Otherwise, go to “Completing the installation” on page 106.

## IDs for hot-swap hard disk drives

The hot-swap-drive ID that is assigned to each drive is printed on the front of the server.

The following illustration shows the location of the IDs of the hard disk drives. The ID numbers and the drive bay numbers are the same.

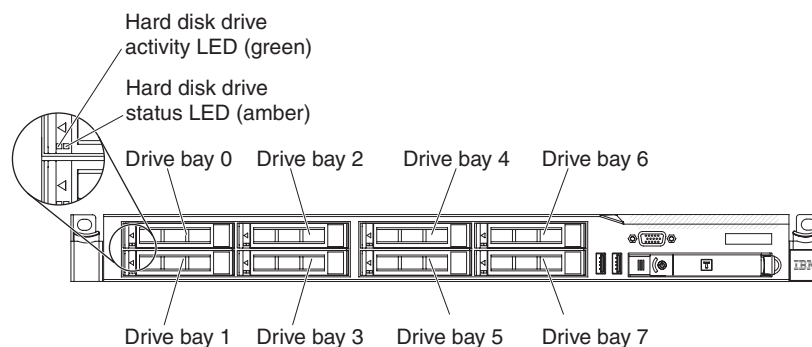

Figure 34. Hot-swap hard disk drive IDs

## Installing a simple-swap hard disk drive

Use this information to install a simple-swap hard disk drive.

### About this task

Some server models support 2.5-inch simple-swap SATA hard disk drives that are accessible from the front of the server. You must turn off the server before installing simple-swap drives in the server. Before you install a simple-swap SATA hard disk drive, read the following information.

- Make sure that the devices that you are installing are supported. For a list of supported optional devices for the server, see <http://www.ibm.com/systems/info/x86servers/serverproven/compat/us/>.
- Locate the documentation that comes with the hard disk drive and follow those instructions in addition to the instructions in this chapter.
- Make sure that you have all the cables and other equipment that are specified in the documentation that comes with the drive.
- Select the bay in which you want to install the drive.
- Check the instructions that come with the drive to determine whether you have to set any switches or jumpers on the drive. If you are installing a SATA device, be sure to set the SATA ID for that device.
- You can install up to four 2.5-inch simple-swap SATA hard disk drives in the server. Do not install hot-swap drives into a simple-swap server model, it is not supported.
- The sequence for installing the hard disk drives is to install the drives starting from bay 0, 1, 2, and 3.
- Simple-swap models of the server do not support the Hypervisor USB flash device and the installation of the SAS/SATA riser card is not supported.
- The simple-swap server models are available only in non-RAID configurations.
- The electromagnetic interference (EMI) integrity and cooling of the server are protected by having all bays and PCI and PCI Express slots covered or occupied. When you install a drive, PCI, or PCI Express adapter, save the EMC shield and filler panel from the bay or PCI or PCI Express adapter slot cover in the event that you later remove the device.

To install a 2.5-inch simple-swap SATA hard disk drive, complete the following steps:

### Procedure

1. Read the safety information that begins on “Safety” on page v and “Installation guidelines” on page 43.
2. Turn off the server and peripheral devices and disconnect the power cords and all external cables.
3. Remove the filler panel from the empty drive bay.
4. Touch the static-protective package that contains the drive to any unpainted metal surface on the server; then, remove the drive from the package and place it on a static-protective surface.
5. Install the hard disk drive in the drive bay:
  - a. Grasp the black drive handle and slide the blue release latch to the right and align the drive assembly with the guide rails in the bay.

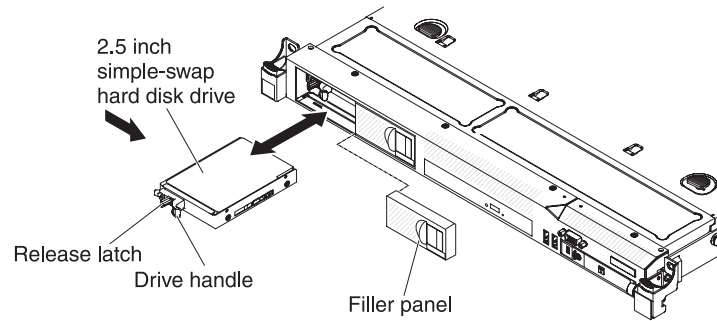

Figure 35. Simple-swap hard disk drive installation

- b. Gently push the drive assembly into the bay until the drive stops.
6. Reinstall the drive bay filler panel that you remove earlier.
7. If you are installing additional simple-swap hard disk drives, do so now.
8. Turn on the peripheral devices and the server.

## Results

If you have other devices to install or remove, do so now. Otherwise, go to “Completing the installation” on page 106.

## IDs for simple-swap hard disk drives

The simple-swap-drive ID that is assigned to each drive is printed on the front of the server.

The following illustration shows the location of the IDs of the hard disk drives. The ID numbers and the drive bay numbers are the same.

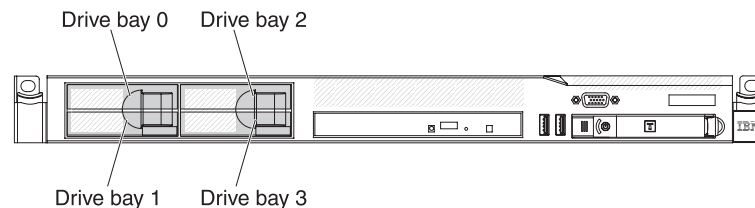

Figure 36. Simple-swap hard disk drive IDs

## Installing an optional DVD drive

Use this information to install an optional DVD drive.

### About this task

**Note:** If your server does not come with a DVD drive bay, you can purchase and install the optical drive cage and bezel option. The option includes the components that allow you to install an optional DVD drive in your server (see “Installing the DVD enablement kit” on page 95).

To install an optional DVD drive, complete the following steps:

### Procedure

1. Read the safety information that begins on “Safety” on page v and “Installation guidelines” on page 43.
2. Turn off the server and peripheral devices and disconnect the power cords and all external cables.
3. Remove the cover (see “Removing the cover” on page 51).
4. Remove the optical drive filler panel if it is installed. Locate the blue release tab on the rear of the optical drive filler panel; then, while you press the tab, push the optical drive filler panel out of the drive bay. Save the optical drive filler panel for future use.

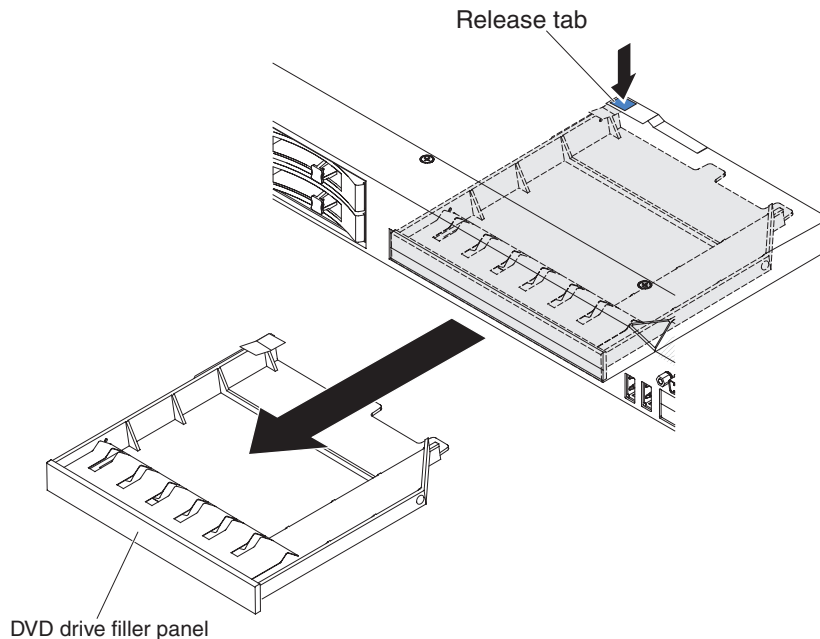

Figure 37. DVD drive filler panel removal

5. Remove the retention clip from the side of the optical drive filler panel.

**Note:** If you are installing a drive that contains a laser, observe the following safety precaution.

#### Statement 3



**CAUTION:**

When laser products (such as CD-ROMs, DVD drives, fiber optic devices, or transmitters) are installed, note the following:

- Do not remove the covers. Removing the covers of the laser product could result in exposure to hazardous laser radiation. There are no serviceable parts inside the device.
- Use of controls or adjustments or performance of procedures other than those specified herein might result in hazardous radiation exposure.



**DANGER**

Some laser products contain an embedded Class 3A or Class 3B laser diode. Note the following.

Laser radiation when open. Do not stare into the beam, do not view directly with optical instruments, and avoid direct exposure to the beam.



Class 1 Laser Product  
Laser Klasse 1  
Laser Klass 1  
Luokan 1 Laserlaite  
Appareil À Laser de Classe 1

6. Touch the static-protective package that contains the new optical drive to any unpainted metal surface on the server; then, remove the optical drive from the package and place it on a static-protective surface.
7. Follow the instructions that come with the DVD drive to set any jumpers or switches.
8. Attach the drive retention clip that you removed from the optical drive filler panel to the side of the DVD drive.

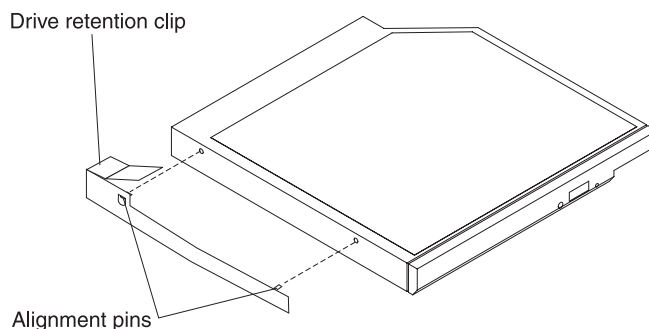

*Figure 38. DVD drive retention clip installation*

9. Align the drive in the drive bay and slide the drive into the optical drive bay until the drive clicks into place.

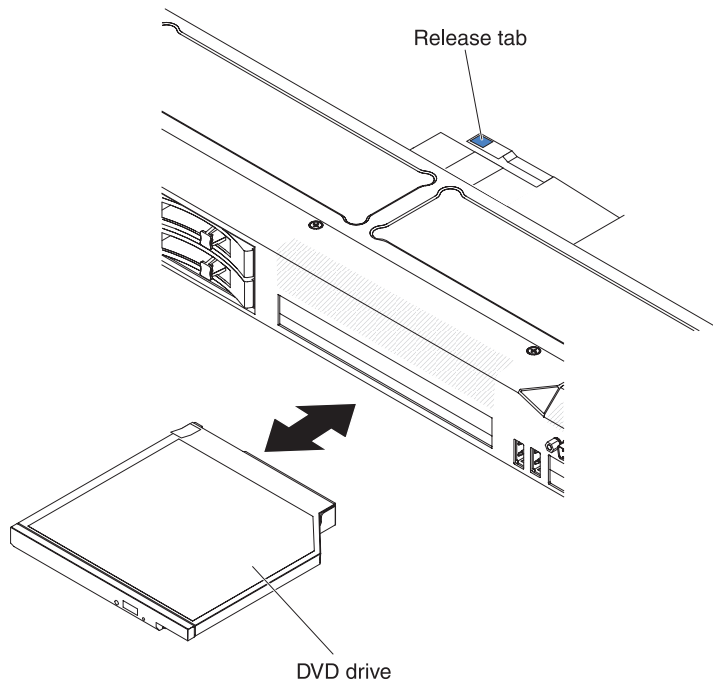

Figure 39. DVD drive installation

## Results

If you have other devices to install or remove, do so now. Otherwise, go to “Completing the installation” on page 106.

---

## Replacing a PCI riser-card assembly

Use this information to replace a PCI riser-card assembly.

### About this task

**Note:** A PCI riser-card assembly must be installed in slot 2 even if you do not install an adapter.

To replace a PCI riser-card assembly, complete the following steps:

### Procedure

1. Read the safety information that begins on “Safety” on page v and “Installation guidelines” on page 43.
2. Turn off the server and peripheral devices and disconnect the power cords and all external cables.
3. Remove the cover (see “Removing the cover” on page 51).
4. If an adapter is installed in the riser-card assembly, disconnect any cables that are connected to the adapter.
5. Grasp the rear of the riser-card assembly from the rear and lift it out of the PCI riser-card slot on the system board.

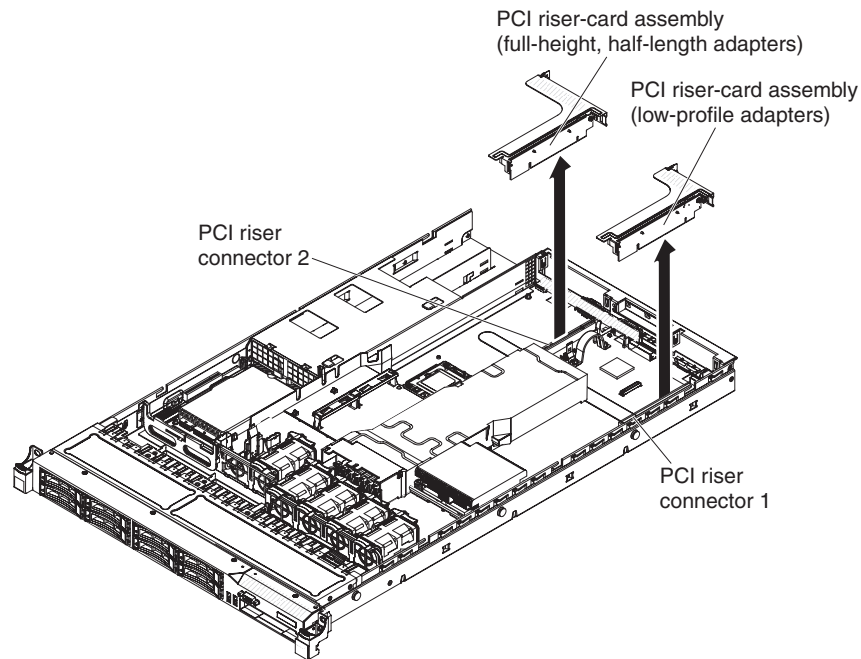

Figure 40. PCI riser-card assembly removal

6. Remove the adapter, if one is present, from the riser-card assembly.
7. Set the adapter and riser-card assembly aside.
8. Install the adapter in the new PCI riser-card assembly (see “Installing an adapter” on page 70).
9. Set any jumpers or switches on the adapter as directed by the adapter manufacturer.
10. If you are installing the PCI riser-card assembly on PCI slot connector 1 on the system board, remove the PCI filler panel from the rear of the server.
11. Align the PCI riser-card assembly with the PCI slot connector on the system board; then, press down firmly until the riser-card assembly is seated correctly in the connector on the system board.

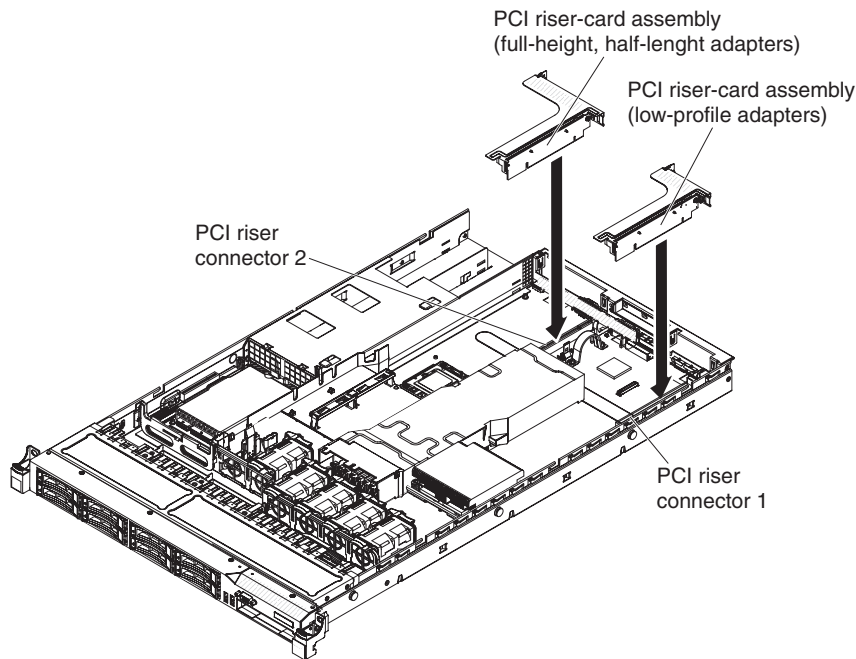

Figure 41. PCI riser-card assembly installation

## Installing an adapter

Use this information to install an adapter.

### About this task

The following notes describe the types of adapters that the server supports and other information that you must consider when you install an adapter:

- To confirm that the server supports the adapter that you are installing, see <http://www.ibm.com/systems/info/x86servers/serverproven/compat/us/>.
- Locate the documentation that comes with the adapter and follow those instructions in addition to the instructions in this section.
- The server provides one SAS/SATA RAID riser-card slot on the system board. See “System-board optional device connectors” on page 42 for the location of the SAS/SATA RAID riser-card slot. The ServeRAID-BR10il v2, ServeRAID-M1015, ServeRAID-M5014, or ServeRAID-M5015 adapter comes installed on some models of the server. You can replace the IBM ServeRAID SAS/SATA adapter with an optional IBM ServeRAID SAS/SATA adapter in the slot. For configuration information, see the ServeRAID documentation at <http://www.ibm.com/supportportal/>.

**Important:** To ensure that any of your ServeRAID 10i, 10is, or 10M adapters function properly on UEFI-based servers, make sure that the adapter firmware level is updated to at least 11.x.x-XXX, and the supporting drivers.

**Attention:** Some cluster solutions require specific code levels or coordinated code updates. If the device is part of a cluster solution, verify that the latest level of code is supported for the cluster solution before you update the code.

- Do not set the maximum digital video adapter resolution above 1600 x 1200 at 75 Hz for an LCD monitor. This is the highest resolution that is supported for any add-on video adapter that you install in the server.

- Any high-definition video-out connector or stereo connector on any add-on video adapter is not supported
- The server does not support full-length adapters.
- When you install any PCI adapter, the power cords must be disconnected from the power source before you remove the PCI Express riser-card assembly and the PCI-X riser-card assembly. Otherwise, the active power management event signal will be disabled by the system-board logic, and the Wake on LAN feature might not work. However, after the server is powered-on locally, the active power manager active power management event signal will be enabled by the system-board logic.
- If you switch the PCI adapter from slot 1 riser assembly to slot 2, you will need to remove the screw from the standard bracket and then replace the standard bracket with the low-profile bracket.
- The server provides two PCI riser-card slots on the system board. A PCI riser assembly with a bracket is installed in slot 2. The following information describes the PCI riser-card slots and the type of adapters that the riser cards support:
  - Standard models of the server come with two PCI Express riser-card assemblies installed. If you want to replace them with PCI-X riser-card assemblies, you must order the PCI-X riser-card assembly option, which includes the bracket.
  - A PCI Express riser-card assembly has a black connector and supports PCI Express adapters, and a PCI-X riser-card assembly has a white (light in color) connector and supports PCI-X adapters.
  - PCI riser slot 1 (the farthest slot from the power supplies). This slot supports only low-profile adapters.
  - PCI riser slot 2 (the closest slot to the power supplies). This slot supports only full-height, half-length adapters.

The following table lists the supported configurations for the PCI riser-card slot.

*Table 14. PCI riser slots supported configurations*

PCI riser-card slot number	Configuration 1	Configuration 2	Configuration 3	Configuration 4
Slot 1	PCI Express Gen 2 (x16) card with a PCI Express riser card with a low-profile bracket	PCI Express Gen 2 (x16) card with a PCI Express riser card with a low-profile bracket	PCI-X 1.0a 64-bit/133 MHz card with a PCI-X riser card with a low-profile bracket	PCI-X 1.0a 64-bit/133 MHz card with a PCI-X riser card with a low-profile bracket
Slot 2	PCI Express Gen 2 (x16) card with a PCI Express riser card with a standard bracket	PCI-X 1.0a 64-bit/133 MHz card with a PCI-X riser card with a standard bracket	PCI Express Gen 2 (x16) card with a PCI Express riser card with a standard bracket	PCI-X 1.0a 64-bit/133 MHz card with a PCI-X riser card with a standard bracket

**Notes:**

1. The instructions in this section apply to any PCI adapter (for example, video graphics adapters or network adapters).
2. Do not set the maximum digital video adapter resolution above 1600 x 1200 at 75 Hz for an LCD monitor. This is the highest resolution that is supported for any add-on video adapter that you install in the server.

3. Any high-definition video-out connector or stereo connector on any add-on video adapter is not supported.

To install an adapter, complete the following steps:

### Procedure

1. Read the safety information that begins on “Safety” on page v and “Installation guidelines” on page 43.
2. Turn off the server and peripheral devices and disconnect all power cords.
3. Remove the cover (see “Removing the cover” on page 51).
4. Follow the cabling instructions, if any come with the adapter. Route the adapter cables before you install the adapter.
5. Insert the adapter into the riser-card assembly, aligning the edge connector on the adapter with the connector on the riser-card assembly. Press the edge of the connector *firmly* into the riser-card assembly. Make sure that the adapter snaps into the riser-card assembly securely.

**Attention:** When you install an adapter, make sure that the adapter is correctly seated in the riser-card assembly and that the riser-card assembly is securely seated in the riser-card connector on the system board before you turn on the server. An incorrectly seated adapter might cause damage to the system board, the riser-card assembly, or the adapter.

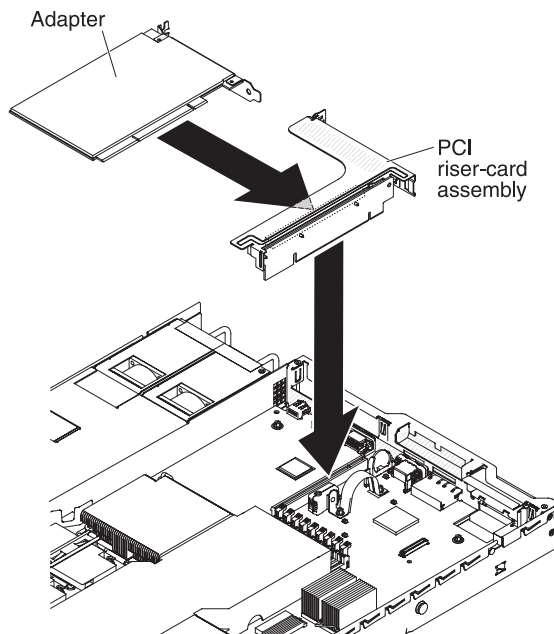

Figure 42. Adapter installation

6. Install the riser-card assembly in the server (see “Replacing a PCI riser-card assembly” on page 68).
7. Perform any configuration tasks that are required for the adapter.

### Results

If you have other devices to install or remove, do so now. Otherwise, go to “Completing the installation” on page 106.

---

## Replacing a PCI Express assembly with a PCI-X assembly

Use this information to replace a PCI Express assembly with a PCI-X assembly.

### About this task

The server comes with one PCI riser-card assembly installed in slot 2. You can replace a PCI Express riser-card assembly with a PCI-X riser-card assembly.

To replace a PCI Express riser-card assembly with a PCI-X riser-card assembly, complete the following steps:

### Procedure

1. Read the safety information that begins on “Safety” on page v and “Installation guidelines” on page 43.
2. Turn off the server and peripheral devices and disconnect all power cords.
3. Remove the cover (see “Removing the cover” on page 51).
4. Remove the PCI Express riser-card assembly from the system board:
  - a. If an adapter is installed in the riser-card assembly, disconnect any cables that are connected to the adapter.
  - b. Grasp the riser-card assembly at the rear edge and lift it from the riser-card connector on the system board.
  - c. Remove the adapter, if one is present, from the riser-card assembly.
  - d. Store the riser-card assembly and the adapter in a safe place for possible future use.
5. Install a PCI-X adapter into the new PCI-X riser-card assembly. See “Installing an adapter” on page 70 for more information. Set any jumpers or switches on the adapter as directed by the adapter manufacturer.

**Note:** You might have to replace the brackets when you replace a PCI Express assembly with a PCI-X assembly.

6. Insert the PCI-X riser-card assembly into the riser-card connector on the system board. Make sure that it is fully seated.

### Results

If you have other devices to install or remove, do so now. Otherwise, go to “Completing the installation” on page 106.

---

## Replacing a PCI-X assembly with a PCI Express assembly

Use this information to replace a PCI-X assembly with a PCI Express assembly.

### About this task

The server comes with one PCI riser-card assembly installed in slot 2. You can replace a PCI-X riser-card assembly with a PCI Express riser-card assembly.

To replace a PCI-X riser-card assembly with a PCI Express riser-card assembly, complete the following steps:

### Procedure

1. Read the safety information that begins on “Safety” on page v and “Installation guidelines” on page 43.
2. Turn off the server and peripheral devices and disconnect all power cords.
3. Remove the cover (see “Removing the cover” on page 51).
4. Remove the PCI-X riser-card assembly from the system board:
  - a. If an adapter is installed in the riser-card assembly, disconnect any cables that are connected to the adapter.
  - b. Grasp the riser-card assembly at the rear edge and lift it from the riser-card connector on the system board.
  - c. Remove the adapter, if one is present, from the riser-card assembly.
  - d. Store the riser-card assembly and the adapter in a safe place for possible future use.
5. Install a PCI Express adapter in the PCI Express riser-card assembly. See “Installing an adapter” on page 70 for more information. Set any jumpers or switches on the adapter as directed by the adapter manufacturer.

**Note:** You might have to replace the bracket when you replace a PCI-X assembly with a PCI Express assembly.

6. Insert the PCI Express riser-card assembly into the riser-card connector on the system board. Make sure that it is fully seated.

### Results

If you have other devices to install or remove, do so now. Otherwise, go to “Completing the installation” on page 106.

---

## Installing a ServeRAID SAS/SATA controller on the SAS/SATA RAID riser card

Use this information to install a ServeRAID SAS/SATA controller on the SAS/SATA RAID riser card.

### About this task

To install a SAS/SATA adapter on the SAS/SATA RAID riser card, complete the following steps:

### Procedure

1. Read the safety information that begins on “Safety” on page v and “Installation guidelines” on page 43.
2. Make sure that the server is turned off, all external cables and power cords are disconnected, and the cover has been removed.
3. If you are installing a new or replacement SAS/SATA adapter, touch the static-protective package that contains the new SAS/SATA adapter to any unpainted metal surface on the server. Then, remove the new SAS/SATA adapter from the package.
4. Align the SAS/SATA adapter so that the keys align correctly with the connector on the SAS/SATA RAID riser-card assembly.

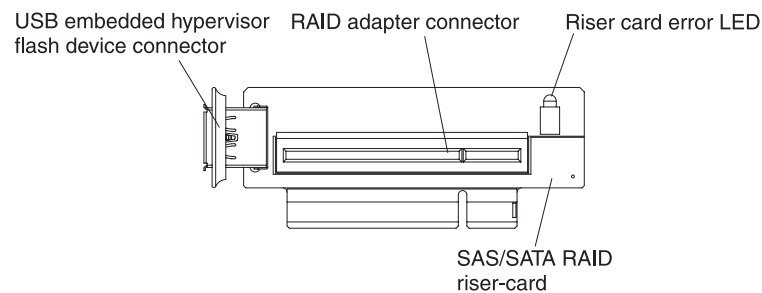

Figure 43. RAID adapter connector

5. Insert the SAS/SATA adapter into the connector on the SAS/SATA RAID riser card until it is firmly seated.

**Attention:** Incomplete insertion might cause damage to the server or the adapter.

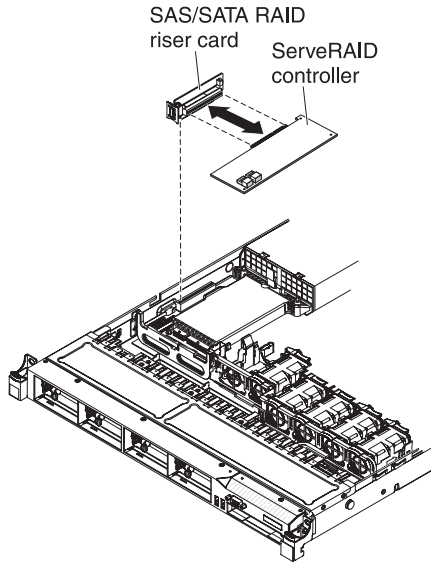

Figure 44. ServeRAID controller installation

6. Align the SAS RAID riser-card assembly keys correctly with the connector on the system board and press down on the assembly until it is seated firmly into the connector on the system board.

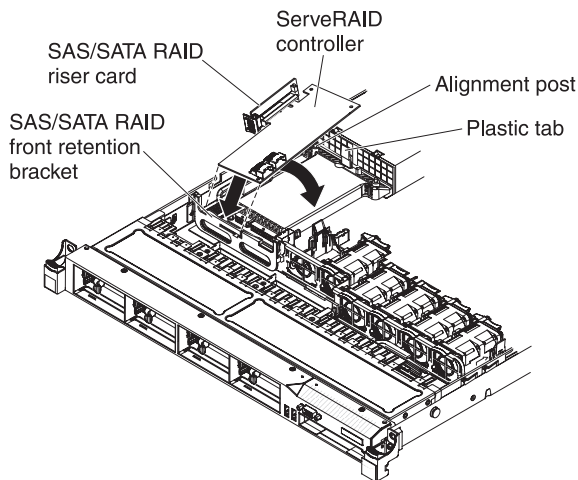

Figure 45. ServeRAID controller installation

7. Route the signal cables from the drive backplane over the blue adapter retention bracket.
8. Connect the signal cables to the SAS/SATA adapter:
  - **ServeRAID-BR10il v2 adapter:** Take the signal cable that is attached to the drive backplane for drive bays 0 through 3 and connect it to the SAS/SATA connector on the ServeRAID adapter.

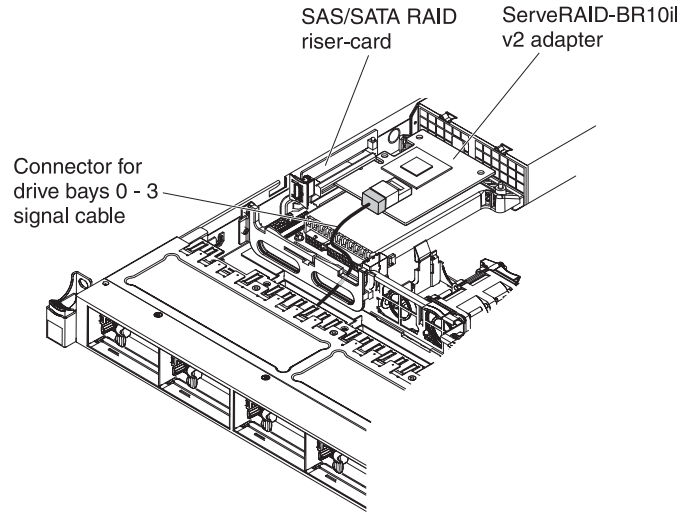

Figure 46. ServeRAID-BR10il v2 adapter cable connection

- **ServeRAID-BR10i, ServeRAID-M1015, ServeRAID-M5014, or ServeRAID-M5015 adapter:** Take the signal cable that is attached to the drive backplane for drive bays 4 through 7 and connect it to the ServeRAID adapter connector that is closest to the power supply cage. Connect the other signal cable so that is attached to the drive backplane for drive bays 0 through 3 and connect it to the other connector on the adapter.

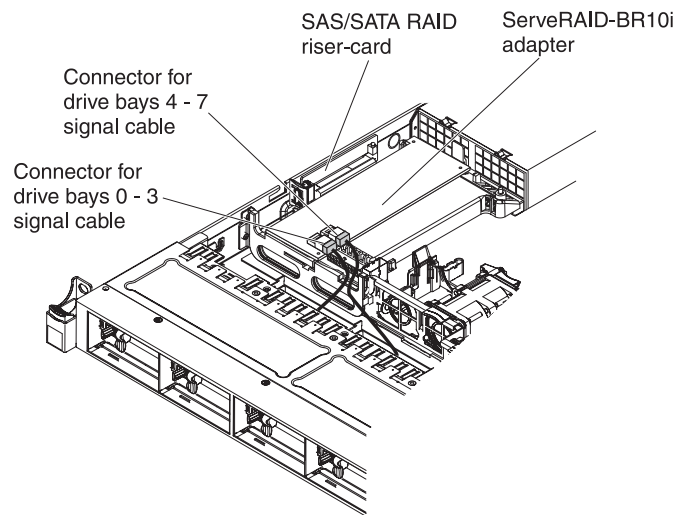

Figure 47. ServeRAID-BR10i adapter cable connection

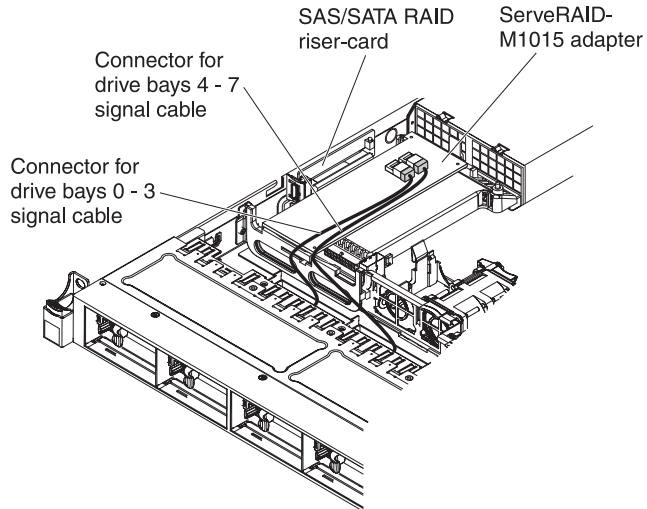

Figure 48. ServeRAID-M5015 adapter cable connection

- **ServeRAID-M10i adapter:** Take the signal cable that is attached to the drive backplane for drive bays 0 through 3 and connect it to the connector on the ServeRAID adapter connector that is closest to the power-supply cage. Connect the other signal cable so that is attached to the drive backplane for drive bays 4 and 7 and connect it to the other connector on the adapter.

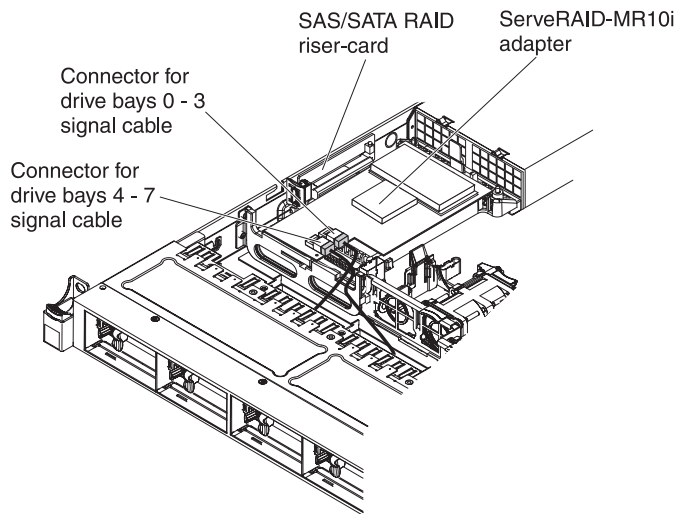

Figure 49. ServeRAID-M10i adapter cable connection

## Results

If you have other devices to install or remove, do so now. Otherwise, go to "Completing the installation" on page 106.

---

## Installing an optional ServeRAID adapter advanced feature key

Use this information to install an optional ServeRAID adapter advanced feature key.

### About this task

To install an optional ServeRAID adapter advanced feature key, complete the following steps:

### Procedure

1. Read the safety information that begins on “Safety” on page v and “Installation guidelines” on page 43.
2. Turn off the server and peripheral devices and disconnect all power cords.
3. Remove the cover (see “Removing the cover” on page 51).
4. Align the upgrade key with the connector on the ServeRAID adapter and push it into the connector until it is firmly seated.

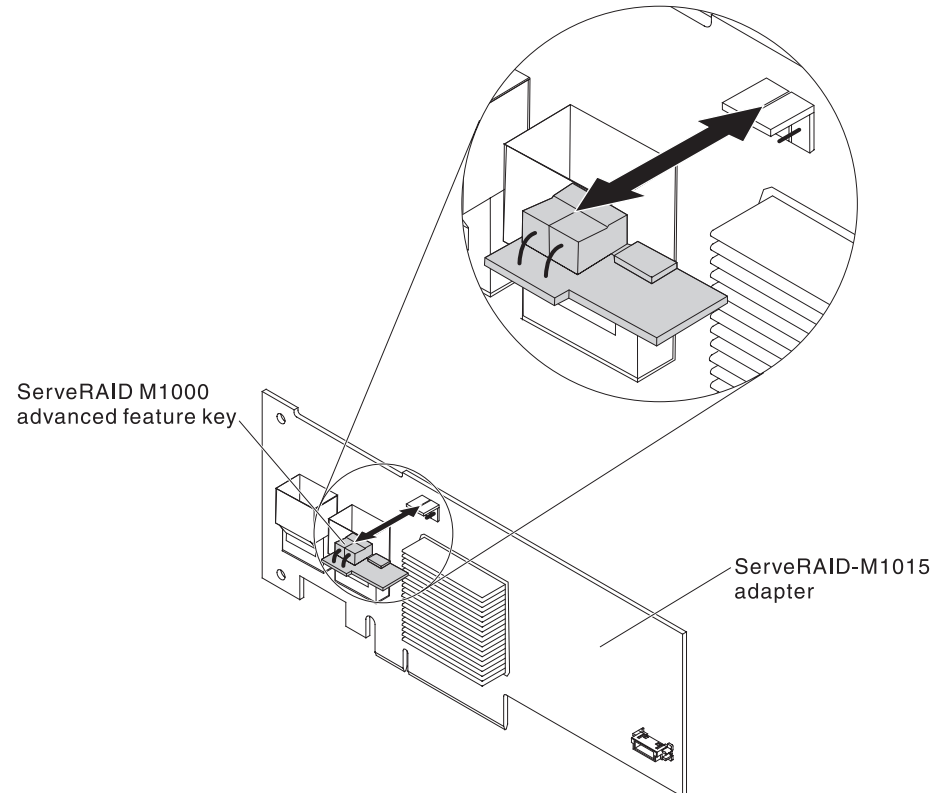

Figure 50. ServeRAID M1000 advanced feature key installation

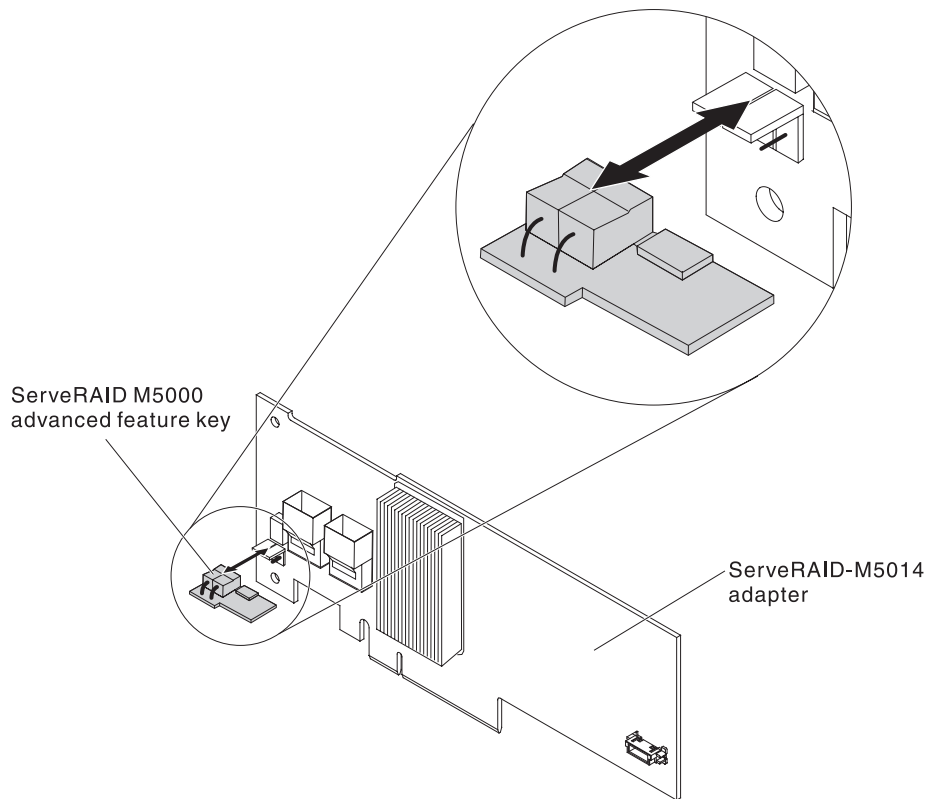

Figure 51. ServeRAID M5000 advanced feature key installation

## Results

If you have other devices to install or remove, do so now. Otherwise, go to “Completing the installation” on page 106.

---

## Installing a hot-swap fan assembly

Use this information to install a hot-swap fan assembly.

### About this task

The server comes standard with five dual-motor hot-swap cooling fans.

**Attention:** To ensure proper operation, replace a failed hot-swap fan within 30 seconds.

To install an additional hot-swap fan, complete the following steps:

### Procedure

1. Read the safety information that begins on “Safety” on page v and “Installation guidelines” on page 43.
2. Remove the cover (see “Removing the cover” on page 51).
3. Touch the static-protective package that contains the new fan to any unpainted metal surface on the server. Then, remove the new fan from the package.

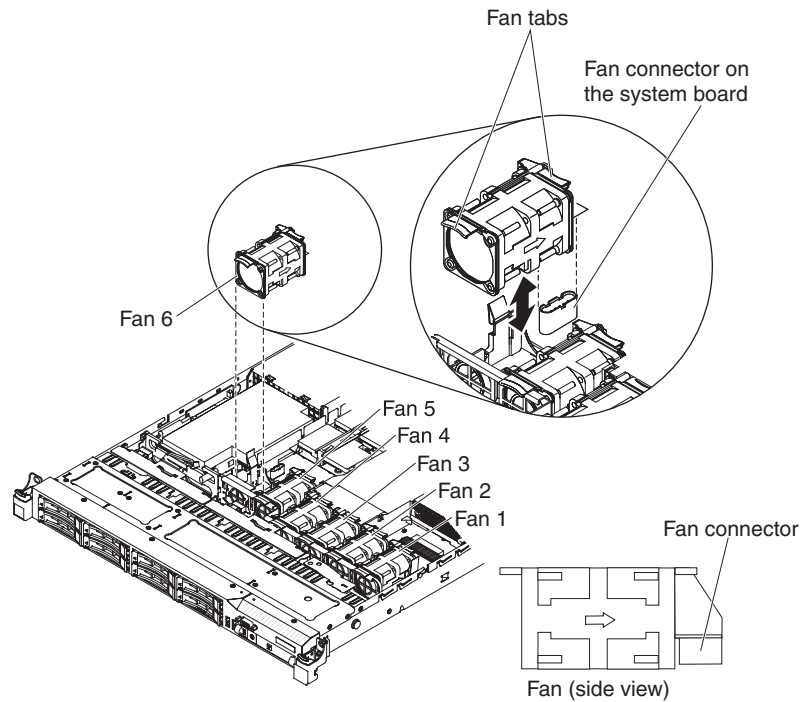

Figure 52. Fan installation

4. Orient the fan over the fan slot in the fan assembly bracket so that the fan connector aligns with the connector on the system board.

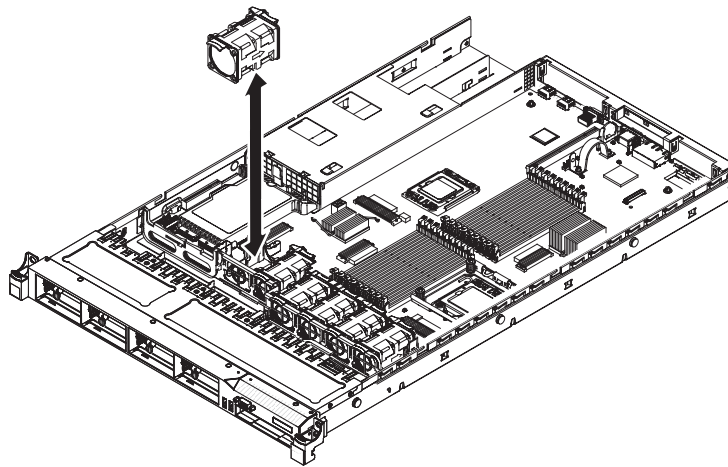

Figure 53. Fan installation

5. Insert the fan into the fan slot in the fan assembly bracket and press it down until it is seated correctly in the slot and the fan connector is seated correctly in the connector on the system board.

## Results

If you have other devices to install or remove, do so now. Otherwise, go to “Completing the installation” on page 106.

## Installing a hot-swap ac power supply

Use this information to install a hot-swap ac power supply.

### About this task

The following notes describe the type of ac power supply that the server supports and other information that you must consider when you install a power supply:

- Make sure that the devices that you are installing are supported. For a list of supported optional devices for the server, see <http://www.ibm.com/systems/info/x86servers/serverproven/compat/us/>.
- Before you install an additional power supply or replace a power supply with one of a different wattage, you may use the IBM Power Configurator utility to determine current system power consumption. For more information and to download the utility, go to <http://www.ibm.com/systems/bladecenter/resources/powerconfig.html>.
- The server comes with one hot-swap 12-volt output power supply that connects to power supply bay 1. The input voltage is 110 V ac or 220 V ac auto-sensing.
- You cannot mix 460-watt and 675-watt power supplies, high-efficiency and non-high-efficiency power supplies, or ac and dc power supplies in the server.
- The following information applies when you install 460-watt power supplies in the server:
  - A warning message is generated if the total power consumption exceeds 400 watts and the server only has one operational 460-watt power supply. In this case, the server can still operate under normal condition. Before you install additional components in the server, you must install an additional power supply
  - The server automatically shuts down if the total power consumption exceeds the total power supply output capacity
  - You can enable the power capping feature in the Setup utility to control and monitor power consumption in the server (see “Setup utility menu choices” on page 113)

The following table shows the system status when you install 460-watt power supplies in the server:

Table 15. System status with 460-watt power supplies installed

Total system power consumption (in watts)	Number of 460-watt power supplies installed		
	One	Two	Two with one failure
< 400	Normal	Normal, redundant power	Normal
400 ~ 460	Normal, status warning	Normal, redundant power	Normal, status warning
> 460	System shutdown	Normal	System shutdown

- Power supply 1 is the default/primary power supply. If power supply 1 fails, you must replace the power supply immediately.
- You can order an optional power supply for redundancy.
- These power supplies are designed for parallel operation. In the event of a power-supply failure, the redundant power supply continues to power the system. The server supports a maximum of two power supplies.

- For instructions on how to install a hot-swap dc power supply, refer to the documentation that comes with the dc power supply.

#### Statement 5



#### CAUTION:

The power control button on the device and the power switch on the power supply do not turn off the electrical current supplied to the device. The device also might have more than one power cord. To remove all electrical current from the device, ensure that all power cords are disconnected from the power source.

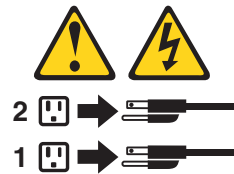

#### Statement 8



#### CAUTION:

Never remove the cover on a power supply or any part that has the following label attached.



Hazardous voltage, current, and energy levels are present inside any component that has this label attached. There are no serviceable parts inside these components. If you suspect a problem with one of these parts, contact a service technician.

To install a hot-swap power supply, complete the following steps:

#### Procedure

1. Read the safety information that begins on “Safety” on page v and “Installation guidelines” on page 43.
2. Touch the static-protective package that contains the hot-swap power supply to any unpainted metal surface on the server; then, remove the power supply from the package and place it on a static-protective surface.
3. If you are installing a hot-swap power supply into an empty bay, remove the power-supply filler panel from the power-supply bay.

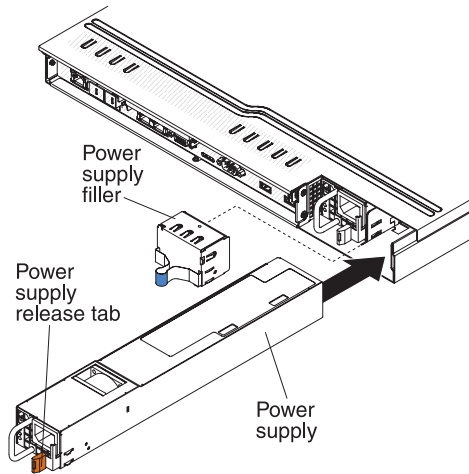

Figure 54. Power supply installation

4. Grasp the handle on the rear of the power supply and slide the power supply forward into the power-supply bay until it clicks. Make sure that the power supply connects firmly into the power-supply connector.
 

**Attention:** Do not install 460-watt and 675-watt power supplies, high-efficiency and non-high-efficiency power supplies, or ac and dc power supplies in the server.
5. Route the power cord through the handle so that it does not accidentally become unplugged.
6. Connect the power cord for the new power supply to the power-cord connector on the power supply.
7. Connect the other end of the power cord to a properly grounded electrical outlet.
8. Make sure that the ac power LED and the dc power LED on the ac power supply are lit, indicating that the power supply is operating correctly. The two green LEDs are to the right of the power-cord connector.
9. If you are replacing a power supply with one of a different wattage, apply the power information label provided with the new power supply over the existing power information label on the server.



Figure 55. Power information label

10. (IBM Business Partners only) Restart the server. Confirm that it starts correctly and recognizes the newly installed devices, and make sure that no error LEDs are lit.

11. (IBM Business Partners only) Complete the additional steps in “Instructions for IBM Business Partners” on page 35.

---

## Installing a USB embedded hypervisor flash device

Use this information to install a USB embedded hypervisor flash device.

### About this task

To install a hypervisor flash device, complete the following steps:

### Procedure

1. Read the safety information that begins on “Safety” on page v and “Installation guidelines” on page 43.
2. Turn off the server and peripheral devices and disconnect the power cords.
3. Remove the cover (see “Removing the cover” on page 51).
4. Align the flash device with the connector on the SAS/SATA RAID riser-card assembly and push it into the connector until it is firmly seated.
5. Slide the blue lockbar toward the flash device to the locked position until it is seated firmly.

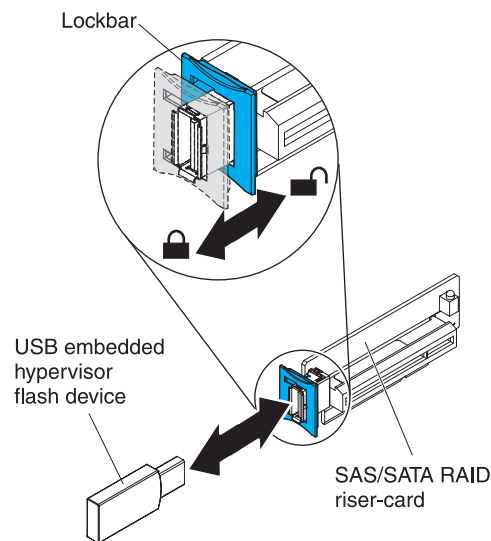

Figure 56. USB embedded hypervisor flash device installation

### Results

If you have other devices to install or remove, do so now. Otherwise, go to “Completing the installation” on page 106.

---

## Installing the virtual media key

Use this information to install the virtual media key.

### About this task

To install the virtual media key, complete the following steps:

### Procedure

1. Read the safety information that begins on “Safety” on page v and “Installation guidelines” on page 43.
2. Turn off the server and peripheral devices and disconnect the power cords.
3. Remove the cover (see “Removing the cover” on page 51).
4. Align the virtual media key with the mounting tab and slide it down the tab onto the connector on the system board. Press the virtual media key down into the connector until it is firmly seated on the system board.

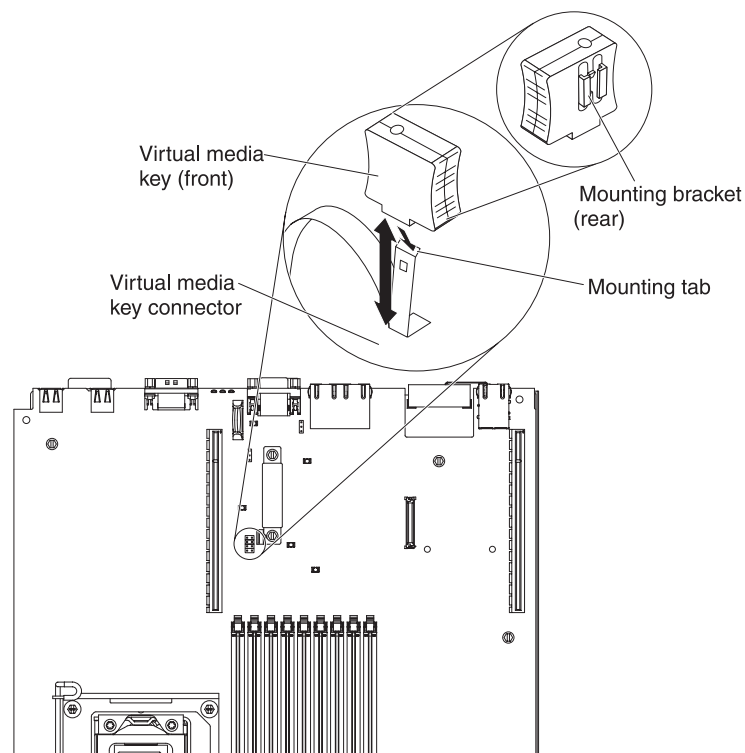

Figure 57. Virtual media key installation

### Results

If you have other devices to install or remove, do so now. Otherwise, go to “Completing the installation” on page 106.

---

## Installing the optional two-port Ethernet adapter

Use this information to install the optional two-port Ethernet adapter.

### About this task

To install the Ethernet adapter, complete the following steps:

### Procedure

1. Read the safety information that begins on “Safety” on page v and “Installation guidelines” on page 43.
2. Turn off the server and peripheral devices and disconnect the power cords.
3. Remove the cover (see “Removing the cover” on page 51).
4. Remove the PCI riser-card assembly (if installed) from PCI riser connector 1 (see “Replacing a PCI riser-card assembly” on page 68).
5. Attach the rubber stopper on the chassis, along the edge of the system board, as shown in the following illustration.

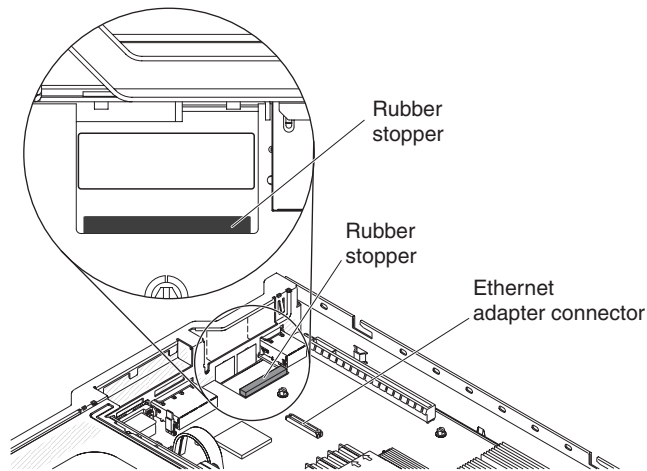

Figure 58. Rubber stopper

6. Remove the adapter filler panel on the rear of the chassis (if it has not been removed already).

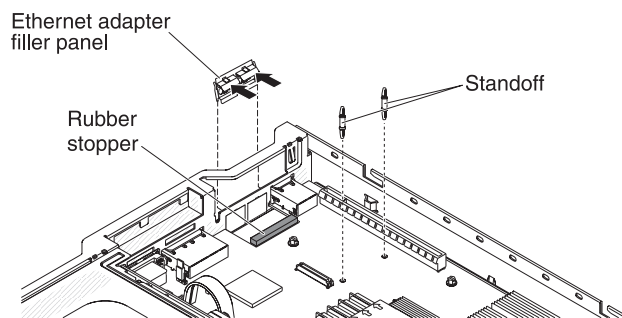

Figure 59. Filler panel removal

7. Install the two standoffs on the system board.

8. Insert the bottom tabs of the metal clip into the port openings from outside the chassis.

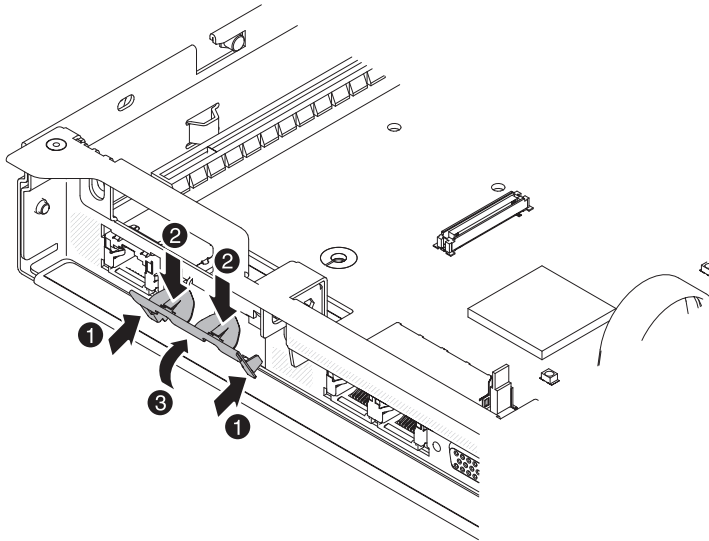

Figure 60. Metal clip installation

9. While you slightly press the top of the metal clip, rotate the metal clip toward the front of the server until the metal clip clicks into place. Make sure the metal clip is securely engaged on the chassis.

**Attention:** Pressing the top of the metal clip with excessive force may cause damage to the metal clip.

10. Touch the static-protective package that contains the new adapter to any unpainted metal surface on the server. Then, remove the adapter from the package.
11. Align the adapter with the adapter connector on the system board; then, tilt the adapter so that the port connectors on the adapter line up with the port openings on the chassis.

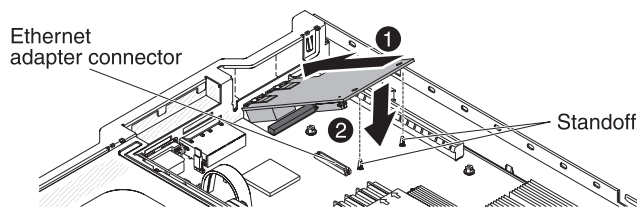

Figure 61. Adapter installation

12. Slide the port connectors on the adapter into the port openings on the chassis; then, press the adapter firmly until the two standoffs engage the adapter. Make sure the adapter is securely seated on the connector on the system board. Make sure the port connectors on the adapter do not set on the rubber stopper. The following illustration shows the side view of the adapter in the server.

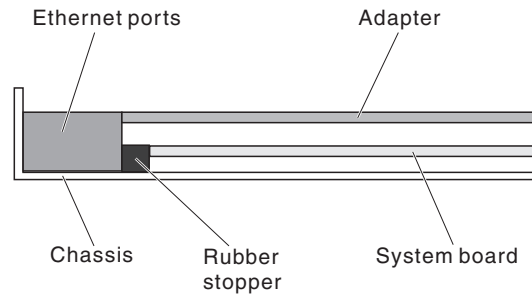

Figure 62. Adapter installation

**Attention:** Make sure the port connectors on the adapter are aligned properly with the chassis on the rear of the server. An incorrectly seated adapter might cause damage to the system board or the adapter.

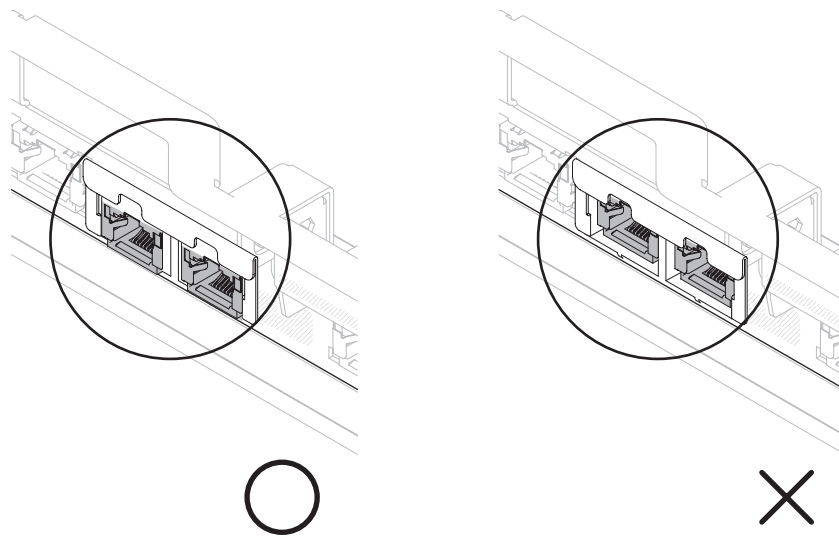

Figure 63. Port connectors

13. Reinstall the PCI riser-card assembly in PCI riser connector 1 if you have removed it previously (see “Replacing a PCI riser-card assembly” on page 68).

## Results

If you have other devices to install or remove, do so now. Otherwise, go to “Completing the installation” on page 106.

---

## Installing a RAID adapter battery remotely in the server

Use this information to install a RAID adapter battery remotely in the server.

### About this task

The batteries must be installed only on top of the microprocessor 2 air baffle. To install a RAID adapter battery in the server, complete the following steps:

### Procedure

1. Read the safety information that begins on “Safety” on page v and “Installation guidelines” on page 43.
2. Turn off the server and peripheral devices and disconnect the power cords.
3. Remove the cover (see “Removing the cover” on page 51).

**Note:** Steps 4 through 5 apply to a RAID adapter that is already installed in the server riser-card. If no RAID adapter is installed, skip to step 6.

4. Remove the riser-card assembly from the server and set it aside (see “Replacing a PCI riser-card assembly” on page 68).
5. Remove the adapter from the riser-card assembly.
6. If a battery and battery carrier are attached to the RAID adapter, disconnect the battery carrier cable from the battery and remove the three screws that secure the battery carrier to the adapter. Set the battery and battery carrier aside.

**Note:** If your battery and battery carrier are attached with a clip, squeeze the clip on the side of the battery carrier to remove the battery from the battery carrier.

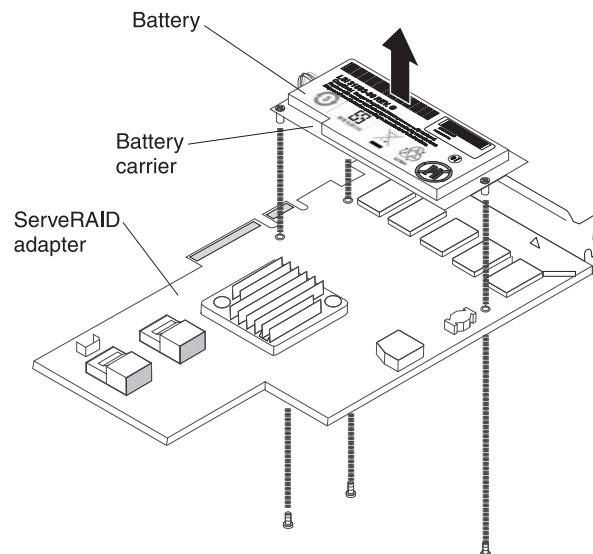

Figure 64. Battery removal

7. Install the interposer card in the interposer card connector on the RAID adapter:
  - a. Remove the interposer card and the screw from the bag.
  - b. Rotate the plastic standoff on the interposer card so that it aligns with the hole on the RAID adapter; then, align the connector on interposer card

with the interposer card connector on the RAID adapter.

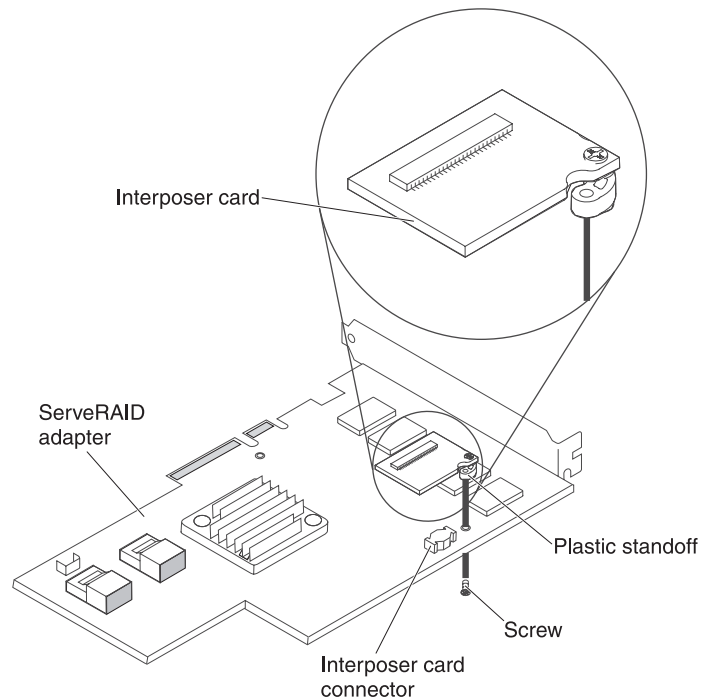

Figure 65. Interposer card installation

- c. Press the interposer card down onto the interposer card connector on the RAID adapter until it is firmly seated.
  - d. From underneath the RAID adapter, insert the screw that you took from the bag and tighten the screw to secure the interposer card to the RAID adapter.
8. Connect one end of the remote batter cable to the interposer card.

**Attention:** To avoid damage to the hardware, make sure that the black dot on the remote battery cable connector faces away from the interposer card on the adapter. Do not force the remote battery cable into the connector.

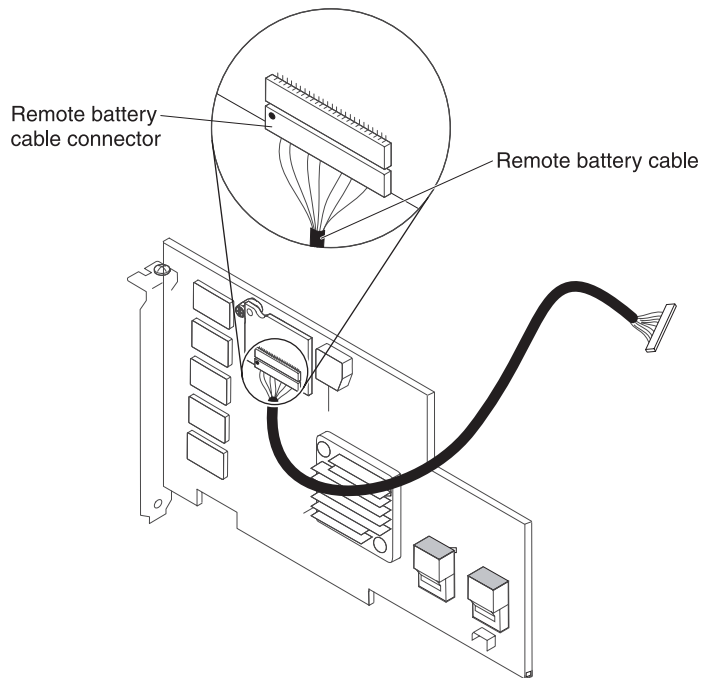

Figure 66. Cable connection

9. Install the RAID adapter on the riser-card and install the riser-card assembly in the server (see "Replacing a PCI riser-card assembly" on page 68).
10. Route the remote battery cable as shown in the illustration, depending on the PCI slot in which the RAID adapter is installed.

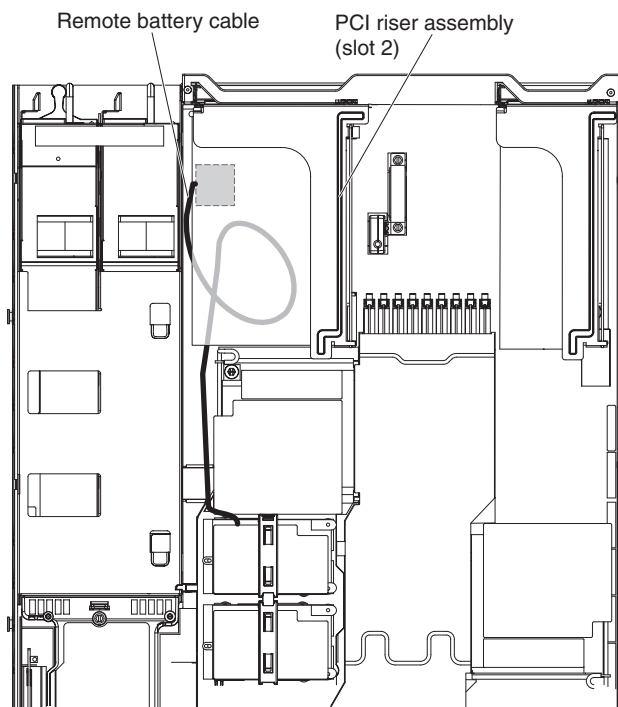

Figure 67. Cable connection

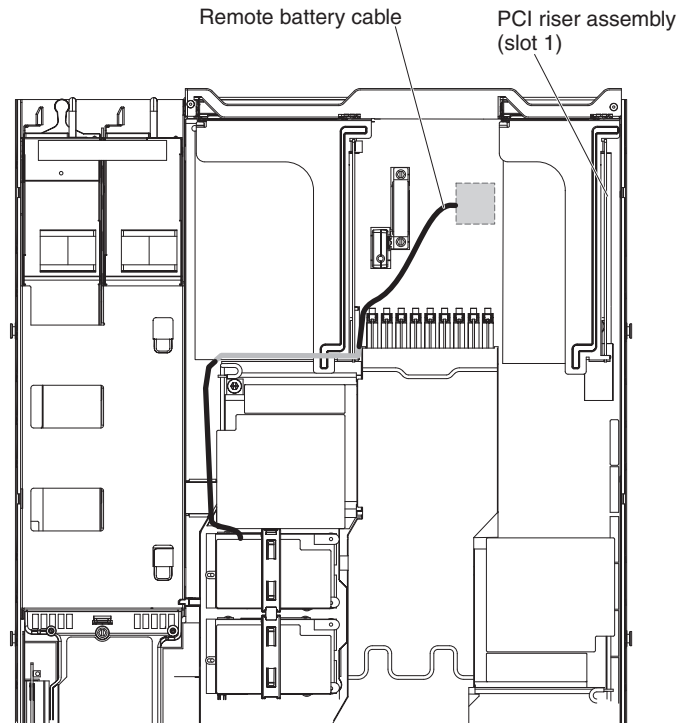

Figure 68. Cable connection

11. Route the remote battery cable through the notches on the microprocessor 2 air baffle.

**Attention:** Make sure that the cable is not pinched and does not cover any connectors or obstruct any components on the system board.

12. Connect the other end of the remote battery cable to the remote battery cable connector on the battery carrier.

**Attention:** To avoid damage to the hardware, make sure that the black dot on the remote battery cable connector faces away from the interposer card on the adapter. Do not force the remote battery cable into the connector.

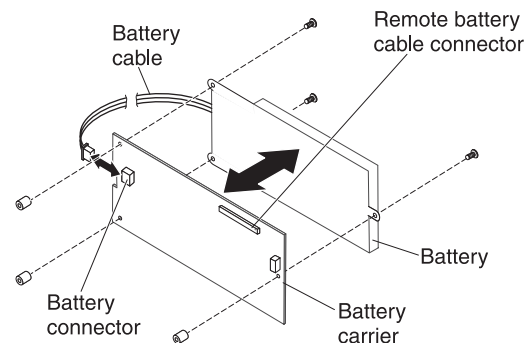

Figure 69. Cable connection

13. Install the battery on the microprocessor 2 air baffle:
  - a. Connect the battery cable to the battery cable connector on the battery carrier.

- b. Place the battery carrier in the battery mounting slot on the microprocessor 2 air baffle and ensure that battery carrier posts align with the rings on the battery mounting slot so that the battery carrier is secure in the slot.

**Note:** The positioning of the remote battery depends on the type of remote battery that you install. The long edge of the battery might fit the recessed rings either parallel or perpendicular to the front bezel.

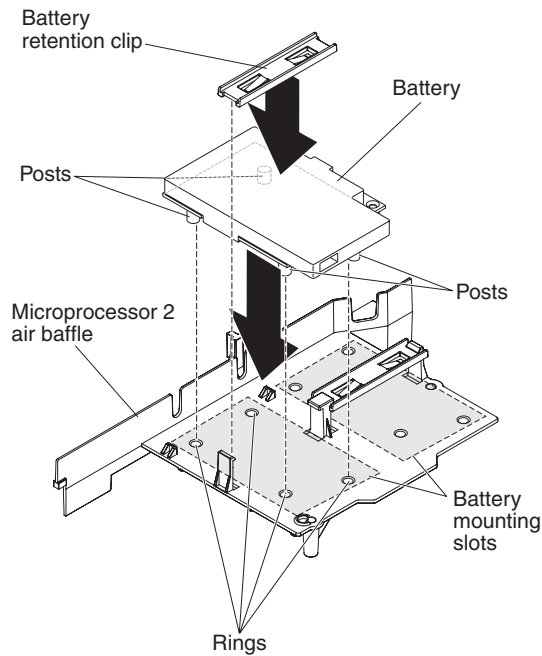

Figure 70. Battery installation

- c. Take the battery retention clip and place it underneath the other tab while pressing release tab toward the front of the server; then, press it down until it snaps in place to hold the battery carrier firmly in place.

## Results

If you have other devices to install or remove, do so now. Otherwise, go to “Completing the installation” on page 106.

---

## Installing the DVD enablement kit

Use this information to install the DVD enablement kit.

### About this task

The IBM System x3550 M3 DVD enablement kit is used to install an optical drive cage in a server with less than four hard disk drives. The optional optical drive cage is installed in the bays for hot-swap hard disk drives 5 to 8.

The DVD enablement option kit contains the following components:

- One optical drive cage
- One optical drive bay filler panel
- One SATA cable
- One retention bracket
- One bezel and screws

To install the DVD enablement kit, complete the following steps:

### Procedure

1. Read the safety information that begins on “Safety” on page v and “Installation guidelines” on page 43.
2. Turn off the server and peripheral devices and disconnect the power cords.
3. Remove the cover (see “Removing the cover” on page 51).
4. Remove the hard disk drives and filler panels from the hard disk drive bays.
5. Remove the screws from the bezel.

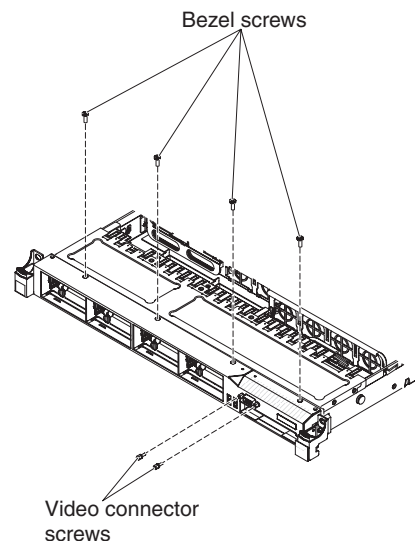

Figure 71. Screws removal

6. Remove the screws from the video connector.
7. Pull the top of the bezel out slightly; then, rotate it downward until the tabs on the bottom of the bezel disengage from the chassis and set it aside.
8. Slide the optical drive cage forward into the optical drive bay until the screw holes on the drive cage align with the screw holes on the chassis.

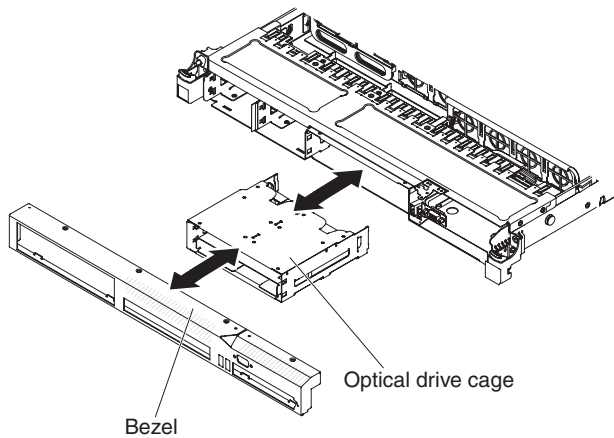

Figure 72. Optical drive cage installation

9. Insert the tabs on the bottom of the bezel into the holes on the chassis.
10. Reinstall the bezel screws and the video connector screws.
11. Align the cable connector with the connector on the rear of the optical drive cage and press the cable connector into the optical drive cage connector until it is firmly seated.
12. Pull the cable connector latch up and hold it there while you slide the cable connector to the left; then, slide the cable connector latch down to lock the cable in place.

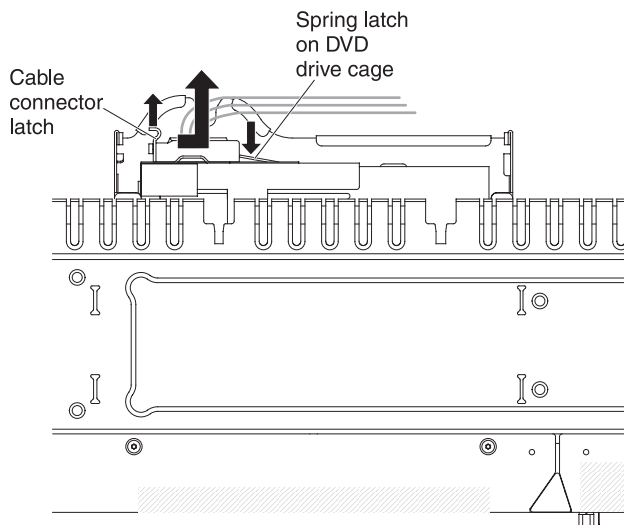

Figure 73. DVD drive cable installation

13. Connect the other end of the DVD cable to the connector on the system board. The following illustration shows the cable routing for the DVD cable: The DVD cable should go on the top of the operation information panel cable (in the middle) and the Video/USB cable (on the bottom) when all three cables are installed in the server.

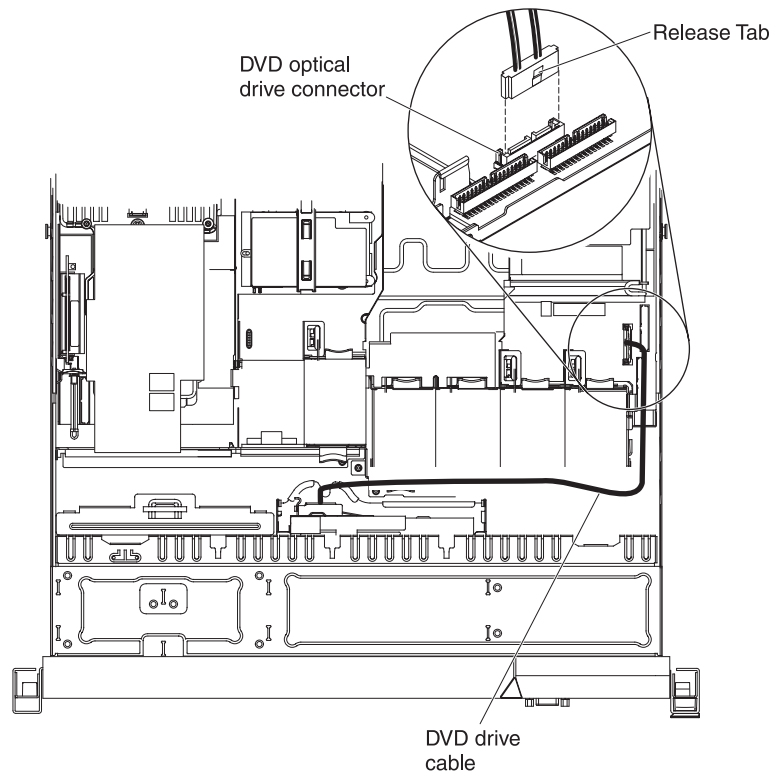

Figure 74. DVD drive cable connection

## Results

If you have other devices to install or remove, do so now. Otherwise, go to “Completing the installation” on page 106.

---

## Installing a SAS/SATA 4 Pac HDD option

Use this information to install a SAS/SATA 4 Pac HDD option.

### About this task

You can install an IBM System x3550 M3 hot-swap SAS/SATA 4 Pac HDD option to add four additional 2.5-inch hot-swap hard disk drives in the server. See <http://www.ibm.com/systems/info/x86servers/serverproven/compat/us/> for a list of supported optional devices. To order a SAS/SATA 4 Pac HDD option, contact your IBM sales representative or IBM reseller.

The SAS/SATA 4 Pac HDD option kit contains the following components:

- One 2.5-inch hard disk drive backplane (with bracket)
- Four drive bay filler panels
- One SAS signal cable
- One 4 Pac hard disk drive cage and screws
- One bezel (depending on the option you purchase)

To install a SAS/SATA 4 Pac HDD option, complete the following steps:

## Procedure

1. Read the safety information that begins on “Safety” on page v and “Installation guidelines” on page 43.
2. Turn off the server and peripheral devices and disconnect the power cords.
3. Remove the cover (see “Removing the cover” on page 51).
4. Remove the hard disk drives and filler panels from the hard disk drive bays.
5. Remove the screws from the bezel.

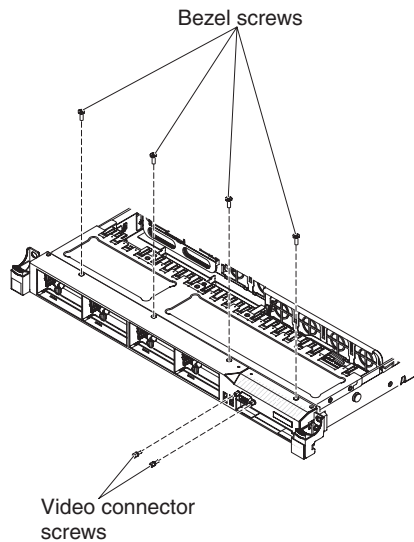

Figure 75. Screws removal

6. Remove the screws from the video connector.
7. Pull the top of the bezel out slightly; then, rotate it downward until the tabs on the bottom of the bezel disengages from the chassis and set it aside.
8. Slide the hot-swap hard disk drive cage forward into the server until the screw holes on the drive cage align with the screw holes on the chassis.

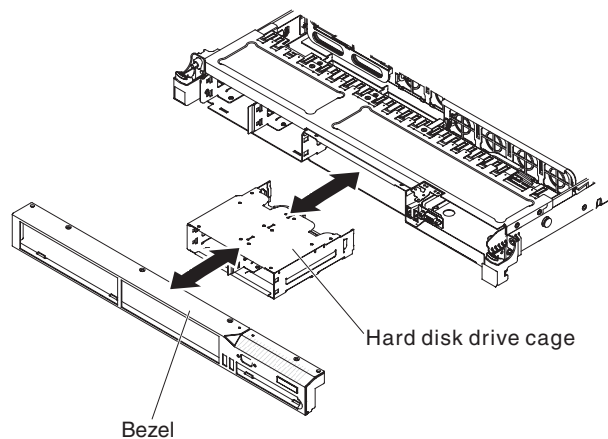

Figure 76. Hard disk drive cage installation

9. Insert the tabs on the bottom of the bezel into the holes on the chassis.
10. Reinstall the bezel screws and the video connector screws.

11. Align the sides of the hard disk drive backplane with the slots on the backplane bracket.
12. Insert the hard disk drive backplane into the slots on the backplane bracket and push the hard disk drive backplane down until the backplane is fully seated.

**Note:** You can reconnect the cables to the hard disk drive backplane before installing the backplane onto the brackets or you can connect the cables after you install the backplane, if that is easier for you.

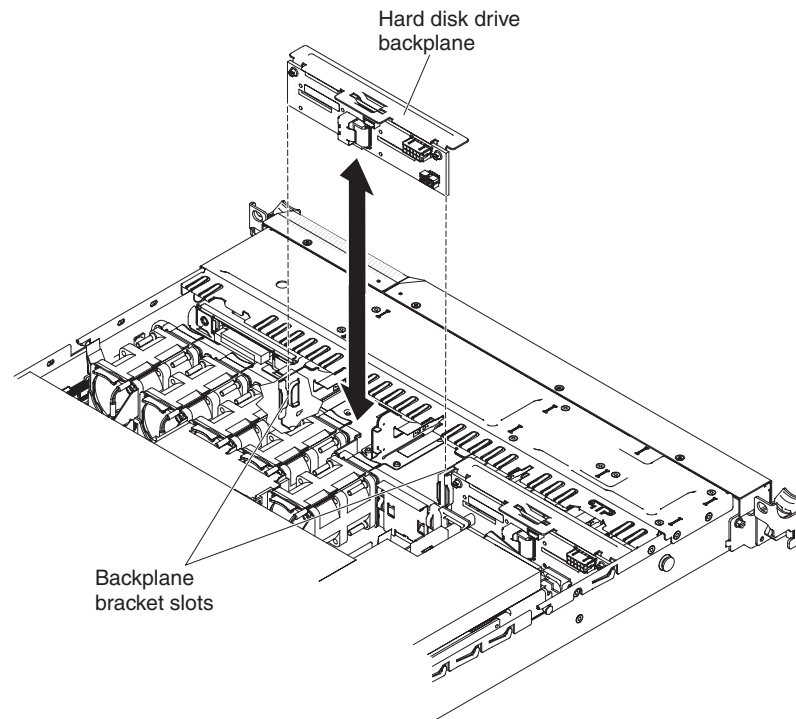

Figure 77. Hard disk drive backplane installation

13. Connect the SATA power cable, the SATA signal cable, and the configuration cable to the hard disk drive backplane (see “Internal cable routing and connectors” on page 46).

**Note:** The configuration cable will not be shipped with this option. The configuration cable is already installed from the system board to the original backplane, this cable is two drops chained cable. Connect the end of this cable to the newly-added 4 Pac HDD backplane.

14. Connect the other end of the SATA signal cable to the connector on the SAS/SATA adapter (see step 8 on page 76).
15. Reinstall the hard disk drives and filler panels.

## Results

If you have other devices to install or remove, do so now. Otherwise, go to “Completing the installation” on page 106.

---

## Installing a second microprocessor and heat sink

Use this information to install a second microprocessor and heat sink.

### About this task

The following notes describe the type of microprocessor that the server supports and other information that you must consider when you install a microprocessor and heat sink:

- Microprocessors are to be installed only by trained service technicians.

**Important:** Always use the microprocessor installation tool to remove a microprocessor. Failing to use the microprocessor installation tool may damage the microprocessor sockets on the system board. Any damage to the microprocessor sockets may require replacing the system board.

- To confirm that the server supports the adapter that you are installing, see <http://www.ibm.com/systems/info/x86servers/serverproven/compat/us/>.
- Microprocessors are to be installed only by trained service technicians.
- The server supports up to two Intel Xeon multi-core microprocessors.
- Do not install an Intel Xeon™ 5500 series microprocessor and an Intel Xeon™ 5600 series microprocessor in the same server.
- Do not mix dual-core, quad-core, and six-core microprocessors in the same server.
- The first microprocessor must always be installed in microprocessor socket 1 on the system board.
- When one microprocessor is installed, a heat sink filler is not required for microprocessor socket 2, however, the microprocessor 2 air baffle, the sixth fan, and the DIMM air baffle must be installed to provide proper system cooling.
- Do not remove the first microprocessor from the system board when you install the second microprocessor.
- When you install the second microprocessor, you must also install additional memory and the sixth fan. See “Installing a memory module” on page 54 for details about the installation sequence.
- To ensure proper server operation when you install an additional microprocessor, use microprocessors that have the same QuickPath Interconnect (QPI) link speed, integrated memory controller frequency, core frequency, power segment, internal cache size, and type.
- Mixing microprocessors of different stepping levels within the same server model is supported.
- When mixing microprocessors with different stepping levels within the same server model, you do not have to install the microprocessor with lowest stepping level and features in microprocessor socket 1.
- Both microprocessor voltage regulator modules are integrated on the system board.
- If you have to replace a microprocessor, call for service.
- Read the documentation that comes with the microprocessor to determine whether you have to update the UEFI firmware. To download the most current level of UEFI firmware for the server, go to <http://www.ibm.com/support/fixcentral/>.
- The microprocessor speeds are automatically set for this server; therefore, you do not have to set any microprocessor frequency-selection jumpers or switches.

- If the thermal-grease protective cover (for example, a plastic cap or tape liner) is removed from the heat sink, do not touch the thermal grease on the bottom of the heat sink or set down the heat sink. For details, see the information about thermal grease in the *Problem and Determination Service Guide*.

**Note:** Removing the heat sink from the microprocessor destroys the even distribution of the thermal grease and requires replacing the thermal grease.

- To order an additional optional microprocessor, contact your IBM marketing representative or authorized reseller.

To install an additional microprocessor and heat sink, complete the following steps:

## Procedure

1. Read the safety information that begins on “Safety” on page v and “Installation guidelines” on page 43.
2. Turn off the server and peripheral devices and disconnect the power cords and all external cables.
3. Remove the cover (see “Removing the cover” on page 51).
4. Locate microprocessor socket 2 on the system board.
5. Remove the microprocessor 2 air baffle (see “Removing the microprocessor 2 air baffle” on page 53).
6. Install the microprocessor:
  - a. Press down and out on the release lever on microprocessor socket 2 and lift up the microprocessor release lever until it stops in the fully open position.
  - b. Lift the hinged microprocessor bracket frame into an open position and remove the microprocessor dust cover, tape, or label from the surface of the microprocessor socket, if one is present. Store the dust cover in a safe place.

**Attention:** When you handle static-sensitive devices, take precautions to avoid damage from static electricity. For details about handling these devices, see “Handling static-sensitive devices” on page 46.

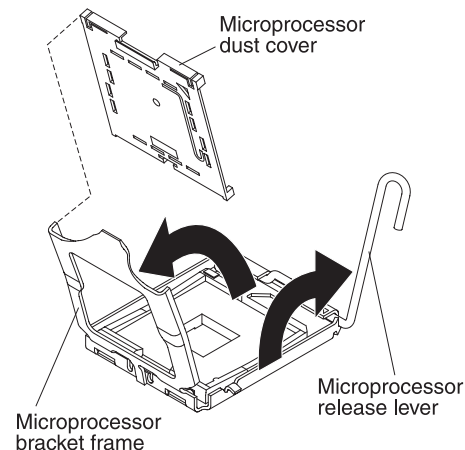

Figure 78. Dust cover removal

- c. Locate the microprocessor installation tool that comes with the new microprocessor.

**Note:** The microprocessor installation tool assembly comes with the microprocessor and microprocessor cover attached to the tool. The

microprocessor comes protected between the tool and the microprocessor cover.

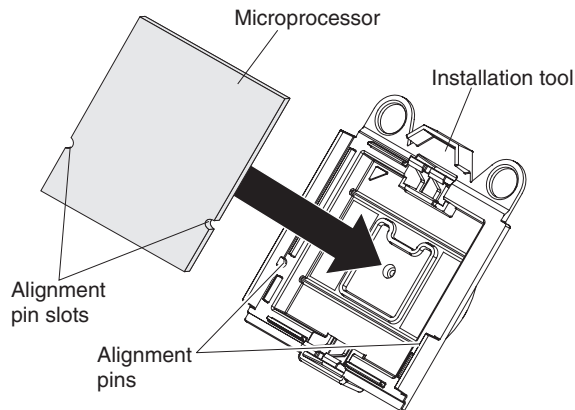

Figure 79. Microprocessor alignment

- d. Remove the microprocessor installation tool assembly from the package.

**Note:** Do not rotate the handle on the tool until you are ready to install the microprocessor into the microprocessor socket.

- e. Remove the cover from the bottom of the microprocessor installation tool. Press both microprocessor cover release tabs outward (in opposite directions as shown in the illustration) and remove the microprocessor installation tool with the microprocessor attached.

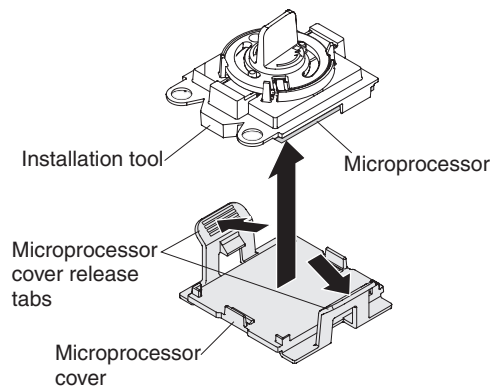

Figure 80. Microprocessor cover removal

- f. Carefully align the microprocessor installation tool over the microprocessor socket.

**Attention:** The microprocessor fits only one way on the socket. You must place a microprocessor straight down on the socket to avoid damaging the pins on the socket. The pins on the socket are fragile. Any damage to the pins may require replacing the system board.

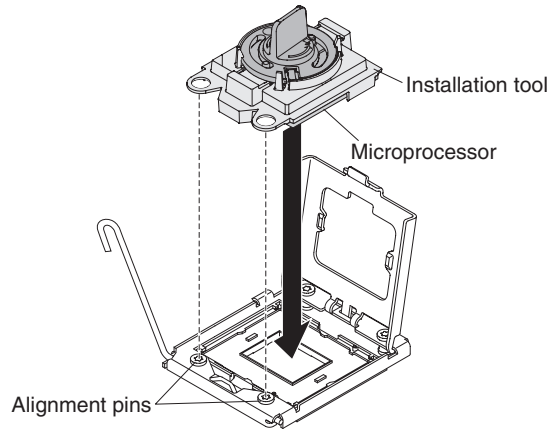

Figure 81. Microprocessor installation

- g. Twist the handle on the microprocessor tool counterclockwise to insert the microprocessor into the socket.

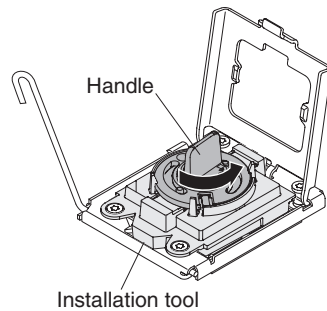

Figure 82. Installation tool handle adjustment

- h. Close the microprocessor bracket frame.
  - i. Carefully close the microprocessor release lever to the closed position to secure the microprocessor in the socket.
7. Install the heat sink:
- a. Remove the plastic protective cover from the bottom of the heat sink.
  - b. Align the heat sink on top of the microprocessor with the thermal grease side down.

**Attention:** Do not touch the thermal grease on the bottom of the heat sink after you remove the plastic cover. Touching the thermal grease will contaminate it. See “Thermal grease” on page 105 for more information.

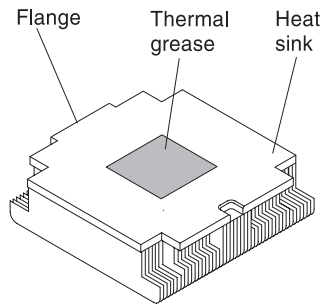

Figure 83. Thermal grease

- c. Lower the rear flange of the heat sink into the opening in the retainer bracket and press down firmly on the front of the heat sink until it is seated securely.

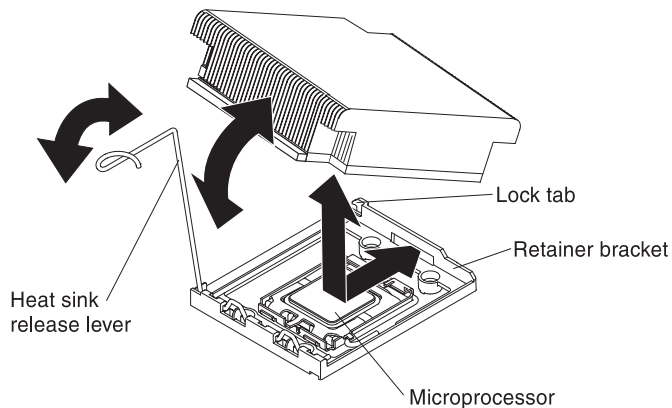

Figure 84. Heat sink installation

- d. Rotate the heat-sink release lever to the closed position and hook it underneath the lock tab.
8. Reinstall the microprocessor 2 air baffle (see "Installing the microprocessor 2 air baffle" on page 106).
9. Install the sixth fan (see "Installing a hot-swap fan assembly" on page 80).

## Results

If you have other devices to install or remove, do so now. Otherwise, go to "Completing the installation" on page 106.

## Thermal grease

The thermal grease must be replaced whenever the heat sink has been removed from the top of the microprocessor and is going to be reused or when debris is found in the grease.

### About this task

When you are installing the heat sink on the same microprocessor that is was removed from, make sure that the following requirements are met:

- The thermal grease on the heat sink and microprocessor is not contaminated.
- Additional thermal grease is not added to the existing thermal grease on the heat sink and microprocessor.

#### Notes:

- Read the safety information that begins on “Safety” on page v.
- Read the “Installation guidelines” on page 43.
- Read “Handling static-sensitive devices” on page 46.

To replace damaged or contaminated thermal grease on the microprocessor and heat sink, complete the following steps:

### Procedure

1. Place the heat sink on a clean work surface.
2. Remove the cleaning pad from its package and unfold it completely.
3. Use the cleaning pad to wipe the thermal grease from the bottom of the heat sink.

**Note:** Make sure that all of the thermal grease is removed.

4. Use a clean area of the cleaning pad to wipe the thermal grease from the microprocessor; then, dispose of the cleaning pad after all of the thermal grease is removed.
5. Use the thermal-grease syringe to place 9 uniformly spaced dots of 0.02 mL each on the top of the microprocessor. The outermost dots must be within approximately 5 mm of the edge of the microprocessor; this is to ensure uniform distribution of the grease.

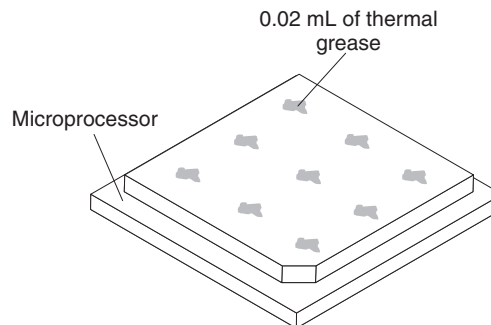

Figure 85. Thermal grease distribution

**Note:** If the grease is properly applied, approximately half of the grease will remain in the syringe.

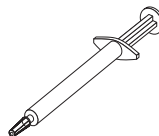

Figure 86. Syringe

6. Install the heat sink onto the microprocessor.

---

## Completing the installation

Use this information to complete the installation.

### About this task

To complete the installation, complete the following steps:

### Procedure

1. If you removed any air baffles, reinstall them (see “Installing the microprocessor 2 air baffle” and “Installing the DIMM air baffle” on page 107).
2. If you removed the cover, replace it (see “Installing the cover” on page 108).
3. Install the server in the rack cabinet (see the *Rack Installation Instructions* that come with the server for instructions).
4. Reconnect the cables and power cords (see “Connecting the cables” on page 109).
5. Update the server configuration (see “Updating the server configuration” on page 110).
6. Slide the server back into the rack, if necessary.
7. Start the server. Confirm that it starts correctly and recognizes the newly installed devices, and make sure that no error LEDs are lit.
8. (IBM Business Partners only) Complete the additional steps in “Instructions for IBM Business Partners” on page 35.

## Installing the microprocessor 2 air baffle

Use this information to install the microprocessor 2 air baffle.

### About this task

To install the air baffle, complete the following steps:

### Procedure

1. Read the safety information that begins on “Safety” on page v and “Installation guidelines” on page 43.
2. Align the microprocessor 2 air baffle tab with the hole on the side of the power-supply cage; then insert the tab into the hole on the cage (make sure that the front end of the air baffle is lined up with the blue touch point tab on the left side of fan 6). Press the air baffle down until it is securely seated.

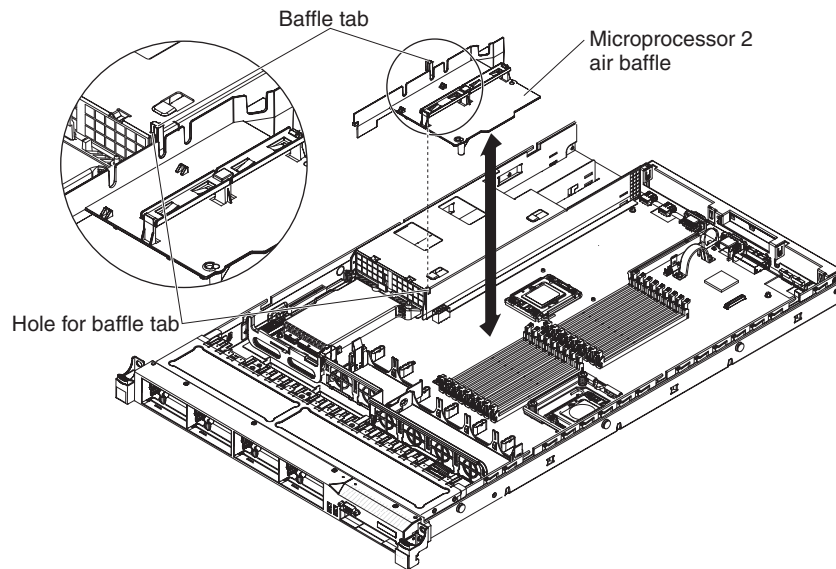

Figure 87. Microprocessor 2 air baffle installation

## Installing the DIMM air baffle

Use this information to install the DIMM air baffle.

### About this task

To install the DIMM air baffle, complete the following steps:

### Procedure

Align the DIMM air baffle over the DIMMs so that the baffle pin on the left side of the air baffle aligns with the pin hole next to DIMM connector 8 on the system board, and lower it into the server.

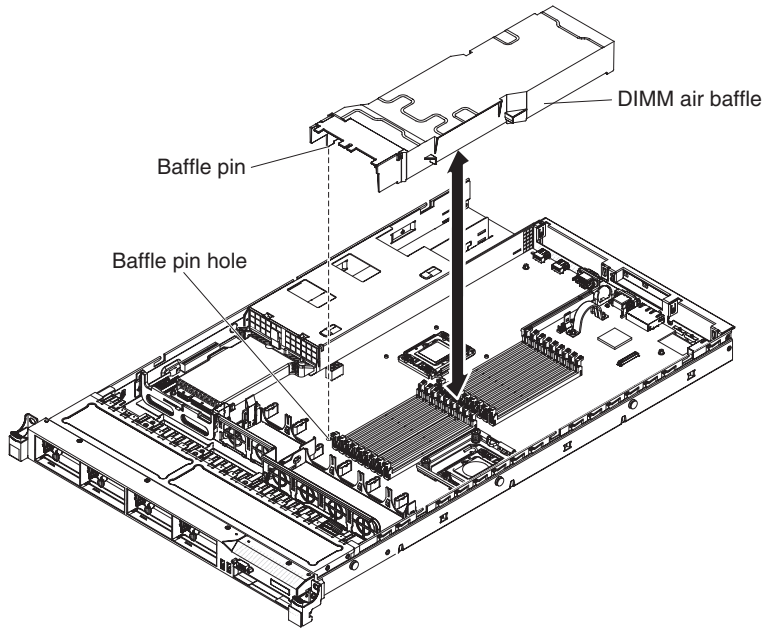

Figure 88. DIMM air baffle installation

## Installing the cover

Use this information to install the cover.

### About this task

To install the server cover, complete the following steps:

#### Procedure

1. Make sure that all cables, adapters, and other components are installed and seated correctly and that you have not left loose tools or parts inside the server. Also, make sure that all internal cables are correctly routed.

**Important:** Before you slide the cover forward, make sure that all the tabs on both the front, rear, and side of the cover engage the chassis correctly. If all the tabs do not engage the chassis correctly, it will be very difficult to remove the cover later.

2. Position the cover on top of the server.

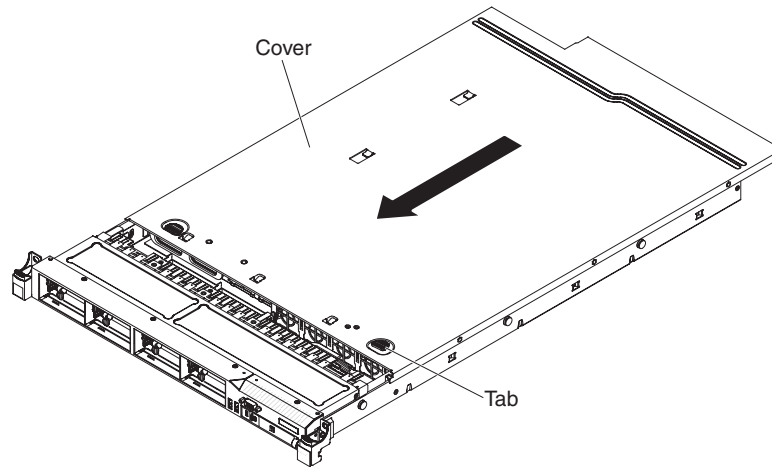

Figure 89. Cover installation

3. Slide the cover toward the front of the server.
4. Make sure that the cover correctly engages all the inset tabs on the server.
5. Slide the server all the way into the rack until it latches.
6. Reconnect the external cables and power cords.

## Connecting the cables

The following illustrations show the locations of the input and output connectors of the server.

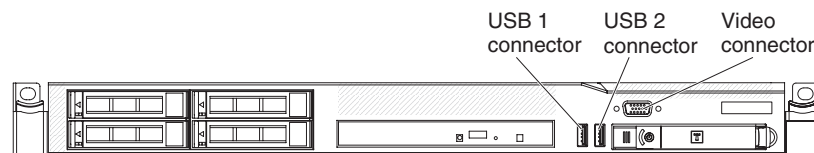

Figure 90. Front of server

The following illustration shows the locations of the input and output connectors on the rear of the server.

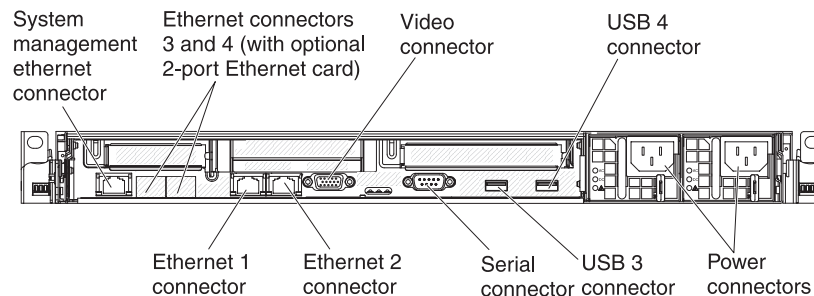

Figure 91. Rear of server

You must turn off the server before you connect or disconnect cables.

See the documentation that comes with any external devices for additional cabling instructions. It might be easier for you to route cables before you connect the

devices to the server.

## **Updating the server configuration**

When you start the server for the first time after you add or remove a device, you might receive a message that the configuration has changed. The Setup utility starts automatically so that you can save the new configuration settings.

Some optional devices have device drivers that you must install. For information about installing device drivers, see the documentation that comes with each device.

If the server has an optional RAID adapter and you have installed or removed a hard disk drive, see the documentation that comes with the RAID adapter for information about reconfiguring the disk arrays.

For information about configuring the integrated Gigabit Ethernet controller, see “Configuring the Gigabit Ethernet controller” on page 127.

---

## Chapter 3. Configuring the server

The following configuration programs come with the server:

The *ServerGuide* program provides software-setup tools and installation tools that are designed for the server. Use this CD during the installation of the server to configure basic hardware features, such as an integrated SAS/SATA controller with RAID capabilities, and to simplify the installation of your operating system. For information about using this CD, see “Using the ServerGuide Setup and Installation CD” on page 120.

In addition to the *ServerGuide Setup and Installation* CD, you can use the following configuration programs to customize the server hardware:

- **Setup utility**

The Setup utility is part of the basic input/output system firmware. Use it to change interrupt request (IRQ) settings, change the startup-device sequence, set the date and time, and set passwords. For information about using this program, see “Using the Setup utility” on page 112.

- **Boot Manager program**

The Boot Manager program is part of the server firmware. Use it to override the startup sequence that is set in the Setup utility and temporarily assign a device to be first in the startup sequence. For more information about using this program, see “Using the Boot Manager program” on page 119.

- **Integrated Management Module**

Use the integrated management module (IMM) for configuration, to update the firmware and sensor data record/field replaceable unit (SDR/FRU) data, and to remotely manage a network. For information about using these programs, see “Using the integrated management module” on page 122.

- **VMware ESXi embedded hypervisor**

The VMware ESXi embedded hypervisor is available on the server models that come with an installed USB embedded hypervisor flash device. The USB flash device is installed in the USB connector on the SAS/SATA RAID riser-card. Hypervisor is virtualization software that enables multiple operating systems to run on a host system at the same time. For more information about using the embedded hypervisor, see “Using the embedded hypervisor” on page 125.

- **Remote presence capability and blue-screen capture**

The remote presence and blue-screen capture feature are integrated into the Integrated Management Module (IMM). The virtual media key is required to enable the remote presence functions. When the optional virtual media key is installed in the server, it activates the remote presence functions. Without the virtual media key, you will not be able to access the network remotely to mount or unmount drives or images on the client system. However, you will still be able to access the host graphical user interface through the Web interface without the Virtual Media Key. You can order the optional IBM Virtual Media Key, if one did not come with your server. For more information about how to enable the remote presence function, see “Using the remote presence capability and blue-screen capture” on page 123.

- **Ethernet controller configuration**

For information about configuring the Ethernet controller, see “Configuring the Gigabit Ethernet controller” on page 127.

- **IBM Advanced Settings Utility (ASU) program**

Use this program as an alternative to the Setup utility for modifying UEFI settings. Use the ASU program online or out of band to modify UEFI settings from the command line without the need to restart the server to access the Setup utility. For more information about using this program, see “IBM Advanced Settings Utility program” on page 130.

- **LSI Configuration Utility program**

Use the LSI Configuration Utility program to configure the integrated SAS/SATA controller with RAID capabilities and the devices that are attached to it. For information about using this program, see “Using the LSI Configuration Utility program” on page 127.

The following table lists the different server configurations and the applications that are available for configuring and managing RAID arrays.

*Table 16. Server configuration and applications for configuring and managing RAID arrays*

<b>Server configuration</b>	<b>RAID array configuration (before operating system is installed)</b>	<b>RAID array management (after operating system is installed)</b>
ServeRAID-BR10i adapter (LSI 1068E)	LSI Utility (Setup utility, press Ctrl+C), ServerGuide	MegaRAID Storage Manager (for monitoring storage only)
ServeRAID-BR10il v2 adapter (LSI 1064E)	LSI Utility (Setup utility, press Ctrl+C), ServerGuide	MegaRAID Storage Manager (MSM), Director
ServeRAID-MR10i adapter (LSI 1078)	MegaRAID BIOS Configuration Utility (press Ctrl+H to start), ServerGuide	MegaRAID Storage Manager (MSM), Director
ServeRAID-M5014 adapter (LSI SAS2108)	MegaCLI (Command Line Interface), ServerGuide	MegaRAID Storage Manager (MSM), Director
ServeRAID-M5015 adapter (LSI SAS2108)	MegaCLI (Command Line Interface), ServerGuide	MegaRAID Storage Manager (MSM), Director
ServeRAID-M1015 adapter (LSI SAS2008)	MegaCLI (Command Line Interface), ServerGuide	MegaRAID Storage Manager (MSM), Director

---

## Using the Setup utility

Use these instructions to start the Setup utility.

Use the Unified Extensible Firmware Interface (UEFI), formerly BIOS, Setup utility to perform the following tasks:

- View configuration information
- View and change assignments for devices and I/O ports
- Set the date and time
- Set the startup characteristics of the server and the order of startup devices
- Set and change settings for advanced hardware features
- View, set, and change settings for power-management features
- View and clear error logs
- Change interrupt request (IRQ) settings
- Resolve configuration conflicts

## Starting the Setup utility

Use this information to start the Setup utility.

### About this task

To start the Setup utility, complete the following steps:

### Procedure

1. Turn on the server.

**Note:** Approximately 20 to 40 seconds after the server is connected to power, the power-control button becomes active.

2. When the prompt <F1> Setup is displayed, press F1. If you have set an administrator password, you must type the administrator password to access the full Setup utility menu. If you do not type the administrator password, a limited Setup utility menu is available.
3. Select settings to view or change.

## Setup utility menu choices

Use the Setup utility main menu to view and configure server configuration data and settings.

The following choices are on the Setup utility main menu for the UEFI. Depending on the version of the firmware, some menu choices might differ slightly from these descriptions.

- **System Information**

Select this choice to view information about the server. When you make changes through other choices in the Setup utility, some of those changes are reflected in the system information; you cannot change settings directly in the system information. This choice is on the full Setup utility menu only.

- **System Summary**

Select this choice to view configuration information, including the ID, speed, and cache size of the microprocessors, machine type and model of the server, the serial number, the system UUID, and the amount of installed memory.

When you make configuration changes through other options in the Setup utility, the changes are reflected in the system summary; you cannot change settings directly in the system summary.

- **Product Data**

Select this choice to view the system-board identifier, the revision level or issue date of the firmware, the integrated management module and diagnostics code, and the version and date.

This choice is on the full Setup utility menu only.

- **System Settings**

Select this choice to view or change the server component settings.

- **Processors**

Select this choice to view or change the processor settings.

- **Memory**

Select this choice to view or change the memory settings.

- **Devices and I/O Ports**

Select this choice to view or change assignments for devices and input/output (I/O) ports. You can configure the serial ports, configure remote console redirection, enable or disable integrated Ethernet controllers, the SAS/SATA controller, SATA optical drive channels, PCI slots, and video controller. If you disable a device, it cannot be configured, and the operating system will not be able to detect it (this is equivalent to disconnecting the device).

- **Power**

Select this choice to view or change power capping to control consumption, processors, and performance states.

- **Operating Modes**

Select this choice to view or change the operating profile (performance and power utilization).

- **Legacy Support**

Select this choice to view or set legacy support.

- **Force Legacy Video on Boot**

- Select this choice to force INT video support, if the operating system does not support UEFI video output standards.

- **Rehook INT 19h**

- Select this choice to enable or disable devices from taking control of the boot process. The default is **Disable**.

- **Legacy Thunk Support**

- Select this choice to enable or disable UEFI to interact with PCI mass storage devices that are non-UEFI compliant.

- **Integrated Management Module**

Select this choice to view or change the settings for the integrated management module.

- **POST Watchdog Timer**

- Select this choice to view or enable the POST watchdog timer.

- **POST Watchdog Timer Value**

- Select this choice to view or set the POST loader watchdog timer value.

- **Reboot System on NMI**

- Enable or disable restarting the system whenever a nonmaskable interrupt (NMI) occurs. **Disabled** is the default.

- **Commands on USB Interface Preference**

- Select this choice to enable or disable the Ethernet over USB interface on IMM.

- **Network Configuration**

- Select this choice to view the system management network interface port, the IMM MAC address, the current IMM IP address, and host name; define the static IMM IP address, subnet mask, and gateway address, specify whether to use the static IP address or have DHCP assign the IMM IP address, save the network changes, and reset the IMM.

- **Reset IMM to Defaults**

- Select this choice to view or reset IMM to the default settings.

- **Reset IMM**

- Select this choice to reset IMM.

- **System Security**

Select this choice to view or configure Trusted Platform Module (TPM) support.

- **Adapters and UEFI Drivers**

Select this choice to view information about the UEFI 1.10 and UEFI 2.0 compliant adapters and drivers installed in the server.

- **Video**

Select this choice to view or configure the video device options.

**Note:** The configuration forms for UEFI 2.1 and greater compliant add-on video devices might be located here.

- **Date and Time**

Select this choice to set the date and time in the server, in 24-hour format (*hour:minute:second*).

This choice is on the full Setup utility menu only.

- **Start Options**

Select this choice to view or change the start options, including the startup sequence, keyboard NumLock state, PXE boot option, and PCI device boot priority. Changes in the startup options take effect when you start the server.

The startup sequence specifies the order in which the server checks devices to find a boot record. The server starts from the first boot record that it finds. If the server has Wake on LAN hardware and software and the operating system supports Wake on LAN functions, you can specify a startup sequence for the Wake on LAN functions. For example, you can define a startup sequence that checks for a disc in the CD-RW/DVD drive, then checks the hard disk drive, and then checks a network adapter.

This choice is on the full Setup utility menu only.

- **Boot Manager**

Select this choice to view, add, delete, or change the device boot priority, boot from a file, select a one-time boot, or reset the boot order to the default setting.

- **System Event Logs**

Select this choice to enter the System Event Manager, where you can view the error messages in the system event logs. You can use the arrow keys to move between pages in the error log.

The system event logs contain all event and error messages that have been generated during POST, by the systems-management interface handler, and by the system service processor. Run the diagnostic programs to get more information about error codes that occur.

**Important:** If the system-error LED on the front of the server is lit but there are no other error indications, clear the IMM system-event log. Also, after you complete a repair or correct an error, clear the IMM system-event log to turn off the system-error LED on the front of the server.

- **POST Event Viewer**

Select this choice to enter the POST event viewer to view the POST error messages.

- **System Event Log**

Select this choice to view the IMM system event log.

- **Clear System Event Log**

Select this choice to clear the IMM system event log.

- **User Security**

Select this choice to set, change, or clear passwords. See “Passwords” for more information.

This choice is on the full and limited Setup utility menu.

- **Set Power-on Password**

Select this choice to set or change a power-on password. For more information, see “Power-on password” on page 117 for more information.

- **Clear Power-on Password**

Select this choice to clear a power-on password. For more information, see “Power-on password” on page 117 for more information.

- **Set Administrator Password**

Select this choice to set or change an administrator password. An administrator password is intended to be used by a system administrator; it limits access to the full Setup utility menu. If an administrator password is set, the full Setup utility menu is available only if you type the administrator password at the password prompt. For more information, see “Administrator password” on page 119.

- **Clear Administrator Password**

Select this choice to clear an administrator password. For more information, see “Administrator password” on page 119.

- **Save Settings**

Select this choice to save the changes that you have made in the settings.

- **Restore Settings**

Select this choice to cancel the changes that you have made in the settings and restore the previous settings.

- **Load Default Settings**

Select this choice to cancel the changes that you have made in the settings and restore the factory settings.

- **Exit Setup**

Select this choice to exit from the Setup utility. If you have not saved the changes that you have made in the settings, you are asked whether you want to save the changes or exit without saving them.

## Passwords

From the **User Security** menu choice, you can set, change, and delete a power-on password and an administrator password.

The **User Security** choice is on the full Setup utility menu only.

If you set only a power-on password, you must type the power-on password to complete the system startup and to have access to the full Setup utility menu.

An administrator password is intended to be used by a system administrator; it limits access to the full Setup utility menu. If you set only an administrator password, you do not have to type a password to complete the system startup, but you must type the administrator password to access the Setup utility menu.

If you set a power-on password for a user and an administrator password for a system administrator, you must type the power-on password to complete the system startup. A system administrator who types the administrator password has access to the full Setup utility menu; the system administrator can give the user authority to set, change, and delete the power-on password. A user who types the

power-on password has access to only the limited Setup utility menu; the user can set, change, and delete the power-on password, if the system administrator has given the user that authority.

### **Power-on password**

If a power-on password is set, when you turn on the server, you must type the power-on password to complete the system startup. You can use any combination of 6 - 20 printable ASCII characters for the password.

When a power-on password is set, you can enable the Unattended Start mode, in which the keyboard and mouse remain locked but the operating system can start. You can unlock the keyboard and mouse by typing the power-on password.

If you forget the power-on password, you can regain access to the server in any of the following ways:

- If an administrator password is set, type the administrator password at the password prompt. Start the Setup utility and reset the power-on password.
- Remove the battery from the server and then reinstall it.
- Change the position of the power-on password switch (enable switch 1 of the system board switch block (SW4) to bypass the power-on password check (see Table 8 on page 40 for more information).

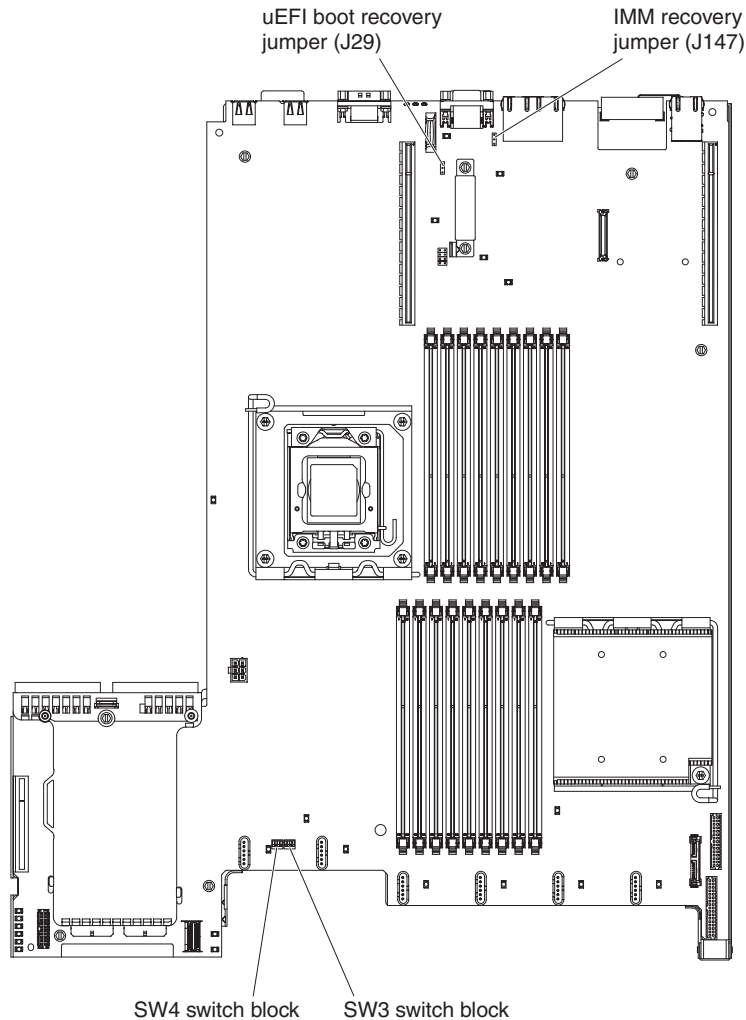

Figure 92. System-board switches and jumpers

**Attention:** Before you change any switch settings or move any jumpers, turn off the server; then, disconnect all power cords and external cables. See the safety information that begins “Safety” on page v. Do not change settings or move jumpers on any system-board switch or jumper blocks that are not shown in this document.

The default for all of the switches on switch block (SW4) is Off.

While the server is turned off, move switch 1 of the switch block (SW4) to the On position to enable the power-on password override. You can then start the Setup utility and reset the power-on password. You do not have to return the switch to the previous position.

The power-on password override switch does not affect the administrator password.

## Administrator password

If an administrator password is set, you must type the administrator password for access to the full Setup utility menu. You can use any combination of 6 to 20 printable ASCII characters for the password.

**Attention:** If you set an administrator password and then forget it, there is no way to change, override, or remove it. You must replace the system board.

---

## Using the Boot Manager program

The Boot Manager program is a built-in, menu-driven configuration utility program that you can use to temporarily redefine the first startup device without changing settings in the Setup utility.

### About this task

To use the Boot Manager program, complete the following steps:

### Procedure

1. Turn off the server.
2. Restart the server.
3. When the prompt <F12> Select Boot Device is displayed, press F12. If a bootable USB mass storage device is installed, a submenu item (**USB Key/Disk**) is displayed.
4. Use the Up arrow and Down arrow keys to select an item from the **Boot Selection Menu** and press Enter.

### Results

The next time the server starts, it returns to the startup sequence that is set in the Setup utility.

---

## Starting the backup server firmware

The system board contains a backup copy area for the server firmware. This is a secondary copy of the server firmware that you update only during the process of updating the server firmware. If the primary copy of the server firmware becomes damaged, use this backup copy.

The system board contains a backup copy area for the server firmware (formerly BIOS firmware). This is a secondary copy of the server firmware that you update only during the process of updating the server firmware. If the primary copy of the server firmware becomes damaged, use this backup copy.

To force the server to start from the backup copy of the server firmware, turn off the server; then, place the J29 jumper in the backup position (pins 2 and 3).

Use the backup copy of the server firmware until the primary copy is restored. After the primary copy is restored, turn off the server; then, move the J29 jumper back to the primary position (pins 1 and 2).

---

## Using the ServerGuide Setup and Installation CD

Use this information as an overview for using the ServerGuide Setup and Installation CD.

The *ServerGuide Setup and Installation* CD provides software setup tools and installation tools that are designed for your server. The ServerGuide program detects the server model and hardware options that are installed and uses that information during setup to configure the hardware. The ServerGuide program simplifies operating-system installations by providing updated device drivers and, in some cases, installing them automatically. To download the CD, go to <http://www.ibm.com/support/entry/portal/docdisplay?lnocid=SERV-GUIDE> and click **IBM Service and Support Site**.

The ServerGuide program has the following features:

- An easy-to-use interface
- Diskette-free setup, and configuration programs that are based on detected hardware
- ServeRAID Manager program, which configures your ServeRAID adapter
- Device drivers that are provided for your server model and detected hardware
- Operating-system partition size and file-system type that are selectable during setup

**Note:** Changes are made periodically to the IBM Web site. The actual procedure might vary slightly from what is described in this document.

### ServerGuide features

This information provides an overview of the ServerGuide features.

Features and functions can vary slightly with different versions of the ServerGuide program. To learn more about the version that you have, start the *ServerGuide Setup and Installation* CD and view the online overview. Not all features are supported on all server models.

The ServerGuide program requires a supported IBM server with an enabled startable (bootable) CD drive. In addition to the *ServerGuide Setup and Installation* CD, you must have your operating-system CD to install the operating system.

The ServerGuide program performs the following tasks:

- Sets system date and time
- Detects the RAID adapter or controller and runs the SAS/SATA RAID configuration program
- Checks the microcode (firmware) levels of a ServeRAID adapter and determines whether a later level is available from the CD
- Detects installed hardware options and provides updated device drivers for most adapters and devices
- Provides diskette-free installation for supported Windows operating systems
- Includes an online readme file with links to tips for your hardware and operating-system installation

## Setup and configuration overview

### ServerGuide setup and configuration overview

When you use the *ServerGuide Setup and Installation* CD, you do not need setup diskettes. You can use the CD to configure any supported IBM server model. The setup program provides a list of tasks that are required to set up your server model. On a server with a ServeRAID adapter or SAS/SATA controller with RAID capabilities, you can run the SAS RAID configuration program to create logical drives.

**Note:** Features and functions can vary slightly with different versions of the ServerGuide program.

When you start the *ServerGuide Setup and Installation* CD, the program prompts you to complete the following tasks:

- Select your language.
- Select your keyboard layout and country.
- View the overview to learn about ServerGuide features.
- View the readme file to review installation tips for your operating system and adapter.
- Start the operating-system installation. You will need your operating-system CD.

**Important:** Before you install a legacy operating system (such as VMware) on a server with an LSI SAS controller, you must first complete the following steps:

1. Update the device driver for the LSI SAS controller to the latest level.
2. In the Setup utility, set **Legacy Only** as the first option in the boot sequence in the **Boot Manager** menu.
3. Using the LSI Configuration Utility program, select a boot drive.

For detailed information and instructions, go to <http://www.ibm.com/support/entry/portal/docdisplay?lnocid=MIGR-5083225>.

## Typical operating-system installation

### ServerGuide typical operating-system installation

The ServerGuide program can reduce the time it takes to install an operating system. It provides the device drivers that are required for your hardware and for the operating system that you are installing. This section describes a typical ServerGuide operating-system installation.

**Note:** Features and functions can vary slightly with different versions of the ServerGuide program.

1. After you have completed the setup process, the operating-system installation program starts. (You will need your operating-system CD to complete the installation.)
2. The ServerGuide program stores information about the server model, service processor, hard disk drive controllers, and network adapters. Then, the program checks the CD for newer device drivers. This information is stored and then passed to the operating-system installation program.
3. The ServerGuide program presents operating-system partition options that are based on your operating-system selection and the installed hard disk drives.

4. The ServerGuide program prompts you to insert your operating-system CD and restart the server. At this point, the installation program for the operating system takes control to complete the installation.

## Installing your operating system without using ServerGuide

Use this information to install the operating system on the server without using ServerGuide.

If you have already configured the server hardware and you are not using the ServerGuide program to install your operating system, go to <http://www.ibm.com/supportportal/> to download the latest operating-system installation instructions from the IBM website.

---

## Using the integrated management module

The integrated management module (IMM) is a second generation of the functions that were formerly provided by the baseboard management controller hardware. It combines service processor functions, video controller, and remote presence function in a single chip.

The IMM supports the following basic system management features:

- Environmental monitor with fan speed control for temperature, voltages, fan failure, and power supply failure.
- Light path diagnostics LEDs indicators to report errors that occur with fans, power supplies, microprocessor, hard disk drives, and system errors.
- DIMM error assistance. The Unified Extensible Firmware Interface (UEFI) disables a failing DIMM that is detected during POST, and the IMM lights the associated system error LED and the failing DIMM error LED.
- System event log (SEL).
- ROM-based IMM firmware flash updates.
- Auto Boot Failure Recovery (ABR).
- A virtual media key, which enables remote presence support (remote video, remote keyboard/mouse, and remote storage).
- Automatic microprocessor disable on failure and restart in a two-microprocessor configuration when one microprocessor signals an internal error.
- Nonmaskable interrupt (NMI) detection and reporting.
- Automatic Server Restart (ASR) when POST is not complete or the operating system hangs and the operating system watchdog timer times-out. The IMM might be configured to watch for the operating system watchdog timer and reboot the system after a timeout, if the ASR feature is enabled. Otherwise, the IMM allows the administrator to generate a nonmaskable interrupt (NMI) by pressing an NMI button on the light path diagnostics panel for an operating-system memory dump. ASR is supported by IPMI.
- Intelligent Platform Management Interface (IPMI) Specification V2.0 and Intelligent Platform Management Bus (IPMB) support.
- Invalid system configuration (CNFG) LED support.
- Serial port redirection over telnet or ssh.
- Serial over LAN (SOL).
- Active Energy Manager
- Query power-supply input power.
- PECI 2 support.

- Power/reset control (power-on, hard and soft shutdown, hard and soft reset, schedule power control).
- Alerts (in-band and out-of-band alerting, PET traps - IPMI style, SNMP, e-mail).
- Operating-system failure blue screen capture.
- Command-line interface.
- Configuration save and restore.
- PCI configuration data.
- Boot sequence manipulation.

The IMM also provides the following remote server management capabilities through the OSA SMBridge management utility program:

- **Command-line interface (IPMI Shell)**

The command-line interface provides direct access to server management functions through the IPMI 2.0 protocol. Use the command-line interface to issue commands to control the server power, view system information, and identify the server. You can also save one or more commands as a text file and run the file as a script.

- **Serial over LAN**

Establish a Serial over LAN (SOL) connection to manage servers from a remote location. You can remotely view and change the UEFI settings, restart the server, identify the server, and perform other management functions. Any standard Telnet client application can access the SOL connection.

---

## Using the remote presence capability and blue-screen capture

The remote presence and blue-screen capture features are integrated functions of the integrated management module (IMM).

When the optional IBM Virtual Media Key is installed in the server, it activates the remote presence functions. The virtual media key is required to enable the integrated remote presence and blue-screen capture features. Without the virtual media key, you will not be able to access the network remotely to mount or unmount drives or images on the client system. However, you can still access the Web interface without the key.

After the virtual media key is installed in the server, it is authenticated to determine whether it is valid. If the key is not valid, you receive a message from the Web interface (when you attempt to start the remote presence feature) indicating that the hardware key is required to use the remote presence feature.

The virtual media key has an LED. When this LED is lit and green, it indicates that the key is installed and functioning correctly. When the LED is not lit, it indicates that the key might not be installed correctly.

The remote presence feature provides the following functions:

- Remotely viewing video with graphics resolutions up to 1600 x 1200 at 75 Hz, regardless of the system state
- Remotely accessing the server, using the keyboard and mouse from a remote client
- Mapping the CD or DVD drive, diskette drive, and USB flash drive on a remote client, and mapping ISO and diskette image files as virtual drives that are available for use by the server

- Uploading a diskette image to the IMM memory and mapping it to the server as a virtual drive

The blue-screen capture feature captures the video display contents before the IMM restarts the server when the IMM detects an operating-system hang condition. A system administrator can use the blue-screen capture to assist in determining the cause of the hang condition.

## Enabling the remote presence feature

Use this information to enable the remote presence feature.

### About this task

To enable the remote presence feature, complete the following steps:

#### Procedure

1. Install the virtual media key into the dedicated slot on the system board (see “System-board optional device connectors” on page 42).
2. Turn on the server.

**Note:** Approximately 20 to 40 seconds after the server is connected to power, the power-control button becomes active.

## Obtaining the IP address for the IMM

To access the web interface, you need the IP address for IMM. You can obtain the IMM IP address through the Setup utility. The server comes with a default IP address for the IMM of 192.168.70.125.

### About this task

To locate the IP address, complete the following steps:

#### Procedure

1. Turn on the server.

**Note:** Approximately 20 to 40 seconds after the server is connected to power, the power-control button becomes active.

2. When the prompt <F1> Setup is displayed, press F1. (This prompt is displayed on the screen for only a few seconds. You must press F1 quickly.) If you have set both a power-on password and an administrator password, you must type the administrator password to access the full Setup utility menu.
3. From the Setup utility main menu, select **System Settings**.
4. On the next screen, select **Integrated Management Module**.
5. On the next screen, select **Network Configuration**.
6. Find the IP address and write it down.
7. Exit from the Setup utility.

## Logging on to the Web interface

Use this information to log on to the web interface.

### About this task

To log onto the Web interface to use the remote presence functions, complete the following steps:

### Procedure

1. Open a Web browser on a computer that connects to the server and in the **Address** or **URL** field, type the IP address or host name of the IMM to which you want to connect.

**Note:** The IMM defaults to DHCP. If a DHCP host is not available, the IMM assigns a static IP address of 192.168.70.125.

2. On the Login page, type the user name and password. If you are using the IMM for the first time, you can obtain the user name and password from your system administrator. All login attempts are documented in the event log.

**Note:** The IMM is set initially with a user name of USERID and password of PASSWORD (passw0rd with a zero, not the letter O). You have read/write access. You must change the default password the first time you log on.

3. On the Welcome page, type a timeout value (in minutes) in the field that is provided. The IMM will log you off of the Web interface if your browser is inactive for the number of minutes that you entered for the timeout value.
4. Click **Continue** to start the session. The System Health page provides a quick view of the system status.

---

## Using the embedded hypervisor

The VMware ESXi embedded hypervisor is available on server models that come with an installed USB embedded hypervisor flash device.

### About this task

The USB flash device comes installed in the USB connector on the SAS/SATA RAID riser card (see the following illustration). Hypervisor is virtualization software that enables multiple operating systems to run on a host system at the same time. The USB flash device is required to activate the hypervisor functions.

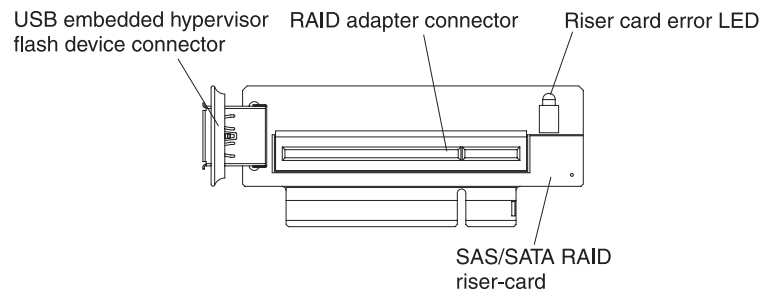

Figure 93. USB embedded hypervisor flash device connector

To start using the embedded hypervisor functions, you must add the USB flash device to the boot order in the Setup utility.

To add the USB flash device to the boot order, complete the following steps:

### Procedure

1. Turn on the server.

**Note:** Approximately 20 to 40 seconds after the server is connected to power, the power-control button becomes active.

2. When the prompt <F1> Setup is displayed, press F1.
3. From the Setup utility main menu, select **Boot Manager**.
4. Select **Add Boot Option > Embedded Hypervisor**. Press Enter, and then select Esc.
5. Select **Change Boot Order** and then select **Commit Changes**; then, press Enter.
6. Select **Save Settings** and then select **Exit Setup**.

## Recovering the flash device image

### About this task

If the embedded hypervisor flash device image becomes corrupt, you can use the *VMware Recovery* CD to recover the flash device image.

To recover the flash device image, complete the following steps:

### Procedure

1. Turn on the server.

**Note:** Approximately 20 to 40 seconds after the server is connected to power, the power-control button becomes active.

2. Insert the VMware Recovery CD into the CD or DVD drive.
3. Follow the instructions on the screen.

### Results

For additional information and instructions, see the *ESXi Embedded and vCenter Server Setup Guide* at [http://www.vmware.com/pdf/vsphere4/r40\\_u1/vsp\\_40\\_u1\\_esxi\\_e\\_vc\\_setup\\_guide.pdf](http://www.vmware.com/pdf/vsphere4/r40_u1/vsp_40_u1_esxi_e_vc_setup_guide.pdf).

---

## Enabling the Broadcom Gigabit Ethernet Utility program

The Broadcom Gigabit Ethernet Utility program is part of the server firmware.

You can use it to configure the network as a startable device, and you can customize where the network startup option appears in the startup sequence. Enable and disable the Broadcom Gigabit Ethernet Utility program from the Setup utility.

---

## Configuring the Gigabit Ethernet controller

The Ethernet controllers are integrated on the system board. They provide an interface for connecting to a 10 Mbps, 100 Mbps, or 1 Gbps network and provide full-duplex (FDX) capability, which enables simultaneous transmission and reception of data on the network.

If the Ethernet ports in the server support auto-negotiation, the controllers detect the data-transfer rate (10BASE-T, 100BASE-TX, or 1000BASE-T) and duplex mode (full-duplex or half-duplex) of the network and automatically operate at that rate and mode.

You do not have to set any jumpers or configure the controllers. However, you must install a device driver to enable the operating system to address the controllers.

To find device drivers and information about configuring the Ethernet controllers, go to <http://www.ibm.com/supportportal/>.

---

## Using the LSI Configuration Utility program

Use the LSI Configuration Utility program to configure and manage redundant array of independent disks (RAID) arrays.

Be sure to use this program as described in this document.

- Use the LSI Configuration Utility program to perform the following tasks:
  - Perform a low-level format on a hard disk drive
  - Create an array of hard disk drives with or without a hot-spare drive
  - Set protocol parameters on hard disk drives

The integrated SAS/SATA controller with RAID capabilities supports RAID arrays. You can use the LSI Configuration Utility program to configure RAID 1 (IM), RAID 1E (IME), and RAID 0 (IS) for a single pair of attached devices. If you install the optional ServeRAID-MR10i SAS/SATA controller, it provides RAID levels 0, 1, 5, 6, 10, 50, and 60 support. If you install a different type of RAID adapter, follow the instructions in the documentation that comes with the adapter to view or change settings for attached devices.

In addition, you can download an LSI command-line configuration program from <http://www.ibm.com/supportportal/>.

When you are using the LSI Configuration Utility program to configure and manage arrays, consider the following information:

- The integrated SAS/SATA controller with RAID capabilities supports the following features:
  - Integrated Mirroring (IM) with hot-spare support (also known as RAID 1)  
Use this option to create an integrated array of two disks plus up to two optional hot spares. All data on the primary disk can be migrated.
  - Integrated Mirroring Enhanced (IME) with hot-spare support (also known as RAID 1E)  
Use this option to create an integrated mirror enhanced array of three to eight disks, including up to two optional hot spares. All data on the array disks will be deleted.

- Integrated Striping (IS) (also known as RAID 0)  
Use this option to create an integrated striping array of two to eight disks. All data on the array disks will be deleted.
- Hard disk drive capacities affect how you create arrays. The drives in an array can have different capacities, but the RAID controller treats them as if they all have the capacity of the smallest hard disk drive.
- If you use an integrated SAS/SATA controller with RAID capabilities to configure a RAID 1 (mirrored) array after you have installed the operating system, you will lose access to any data or applications that were previously stored on the secondary drive of the mirrored pair.
- If you install a different type of RAID controller, see the documentation that comes with the controller for information about viewing and changing settings for attached devices.

## Starting the LSI Configuration Utility program

Use this information to start the LSI Configuration Utility program.

### About this task

To start the LSI Configuration Utility program, complete the following steps:

### Procedure

1. Turn on the server.

**Note:** Approximately 20 to 40 seconds after the server is connected to power, the power-control button becomes active.

2. When the prompt <F1 Setup> is displayed, press F1. If you have set an administrator password, you are prompted to type the password.
3. Select **System Settings > Adapters and UEFI drivers**.
4. Select **Please refresh this page on the first visit** and press Enter.
5. Select **LSI controller\_driver\_name Driver** and press Enter, where *controller\_driver\_name* is the name of the SAS/SATA controller driver. For the SAS/SATA controller driver name, see the documentation that comes with your controller.
6. To perform storage-management tasks, follow the procedures in the documentation that comes with the SAS/SATA controller.

### Results

When you have finished changing settings, press Esc to exit from the program; select **Save** to save the settings that you have changed.

## Formatting a hard disk drive

Low-level formatting removes all data from the hard disk. If there is data on the disk that you want to save, back up the hard disk before you perform this procedure.

### About this task

**Note:** Before you format a hard disk, make sure that the disk is not part of a mirrored pair.

To format a drive, complete the following steps:

### Procedure

1. From the list of adapters, select the controller (channel) for the drive that you want to format and press Enter.
2. Select **SAS Topology** and press Enter.
3. Select **Direct Attach Devices** and press Enter.
4. To highlight the drive that you want to format, use the Up Arrow and Down Arrow keys. To scroll left and right, use the Left Arrow and Right Arrow keys or the End key. Press Alt+D.
5. To start the low-level formatting operation, select **Format** and press Enter.

## Creating a RAID array of hard disk drives

Use this information to create a RAID array of hard disk drives.

### About this task

To create a RAID array of hard disk drives, complete the following steps:

### Procedure

1. From the list of adapters, select the controller (channel) for the drives that you want to mirror.
2. Select **RAID Properties**.
3. Select the type of array that you want to create.
4. Use the arrow keys to highlight the first drive in the pair; then, press the Minus (-) or Plus (+) key to change the mirror value to **Primary**.
5. Continue to select the next drive using the Minus (-) or Plus (+) key until you have selected all the drives for your array.
6. Press C to create the disk array.
7. Select **Apply changes and exit menu** to create the array.

---

## IBM Advanced Settings Utility program

The IBM Advanced Settings Utility (ASU) program is an alternative to the Setup utility for modifying UEFI settings.

Use the ASU program online or out of band to modify UEFI settings from the command line without the need to restart the system to access the Setup utility.

You can also use the ASU program to configure the optional remote presence features or other IMM settings. The remote presence features provide enhanced systems-management capabilities.

In addition, the ASU program provides limited settings for configuring the IPMI function in the IMM through the command-line interface.

Use the command-line interface to issue setup commands. You can save any of the settings as a file and run the file as a script. The ASU program supports scripting environments through a batch-processing mode.

For more information and to download the ASU program, go to <http://www.ibm.com/support/entry/portal/docdisplay?lnocid=TOOL-ASU>.

---

## Updating IBM Systems Director

If you plan to use IBM Systems Director to manage the server, you must check for the latest applicable IBM Systems Director updates and interim fixes.

### About this task

**Note:** Changes are made periodically to the IBM website. The actual procedure might vary slightly from what is described in this document.

## Installing a newer version

### About this task

To locate and install a newer version of IBM Systems Director, complete the following steps:

### Procedure

1. Check for the latest version of IBM Systems Director:
  - a. Go to <http://www.ibm.com/systems/management/director/downloads.html>.
  - b. If a newer version of IBM Systems Director than what comes with the server is shown in the drop-down list, follow the instructions on the web page to download the latest version.
2. Install the IBM Systems Director program.

## Installing updates with your management server is connected to the Internet

### About this task

If your management server is connected to the Internet, to locate and install updates and interim fixes, complete the following steps:

### Procedure

1. Make sure that you have run the Discovery and Inventory collection tasks.
2. On the Welcome page of the IBM Systems Director web interface, click **View updates**.
3. Click **Check for updates**. The available updates are displayed in a table.
4. Select the updates that you want to install, and click **Install** to start the installation wizard.

## Installing updates with your management server is not connected to the Internet

### About this task

If your management server is not connected to the Internet, to locate and install updates and interim fixes, complete the following steps:

### Procedure

1. Make sure that you have run the Discovery and Inventory collection tasks.
2. On a system that is connected to the Internet, go to <http://www.ibm.com/support/fixcentral/>.
3. From the **Product family** list, select **IBM Systems Director**.
4. From the **Product** list, select **IBM Systems Director**.
5. From the **Installed version** list, select the latest version, and click **Continue**.
6. Download the available updates.
7. Copy the downloaded files to the management server.
8. On the management server, on the Welcome page of the IBM Systems Director web interface, click the **Manage** tab, and click **Update Manager**.
9. Click **Import updates** and specify the location of the downloaded files that you copied to the management server.
10. Return to the Welcome page of the Web interface, and click **View updates**.
11. Select the updates that you want to install, and click **Install** to start the installation wizard.

---

## The Update*Xpress* System Pack Installer

The Update*Xpress* System Pack Installer detects supported and installed device drivers and firmware in the server and installs available updates.

For additional information and to download the Update*Xpress* System Pack Installer, go to the ToolsCenter for System x and BladeCenter at <http://publib.boulder.ibm.com/infocenter/toolsctr/v1r0/> and click **Update*Xpress* System Pack Installer**.

---

## Appendix. Getting help and technical assistance

If you need help, service, or technical assistance or just want more information about IBM products, you will find a wide variety of sources available from IBM to assist you.

Use this information to obtain additional information about IBM and IBM products, determine what to do if you experience a problem with your IBM system or optional device, and determine whom to call for service, if it is necessary.

---

### Before you call

Before you call, make sure that you have taken these steps to try to solve the problem yourself.

If you believe that you require IBM to perform warranty service on your IBM product, the IBM service technicians will be able to assist you more efficiently if you prepare before you call.

- Check all cables to make sure that they are connected.
- Check the power switches to make sure that the system and any optional devices are turned on.
- Check for updated software, firmware, and operating-system device drivers for your IBM product. The IBM Warranty terms and conditions state that you, the owner of the IBM product, are responsible for maintaining and updating all software and firmware for the product (unless it is covered by an additional maintenance contract). Your IBM service technician will request that you upgrade your software and firmware if the problem has a documented solution within a software upgrade.
- If you have installed new hardware or software in your environment, check <http://www.ibm.com/systems/info/x86servers/serverproven/compat/us/> to make sure that the hardware and software is supported by your IBM product.
- Go to <http://www.ibm.com/supportportal/> to check for information to help you solve the problem.
- Gather the following information to provide to IBM Support. This data will help IBM Support quickly provide a solution to your problem and ensure that you receive the level of service for which you might have contracted.
  - Hardware and Software Maintenance agreement contract numbers, if applicable
  - Machine type number (IBM 4-digit machine identifier)
  - Model number
  - Serial number
  - Current system UEFI and firmware levels
  - Other pertinent information such as error messages and logs
- Go to [http://www.ibm.com/support/entry/portal/Open\\_service\\_request/](http://www.ibm.com/support/entry/portal/Open_service_request/) to submit an Electronic Service Request. Submitting an Electronic Service Request will start the process of determining a solution to your problem by making the pertinent information available to IBM Support quickly and efficiently. IBM service technicians can start working on your solution as soon as you have completed and submitted an Electronic Service Request.

You can solve many problems without outside assistance by following the troubleshooting procedures that IBM provides in the online help or in the documentation that is provided with your IBM product. The documentation that comes with IBM systems also describes the diagnostic tests that you can perform. Most systems, operating systems, and programs come with documentation that contains troubleshooting procedures and explanations of error messages and error codes. If you suspect a software problem, see the documentation for the operating system or program.

---

## Using the documentation

Information about your IBM system and preinstalled software, if any, or optional device is available in the documentation that comes with the product. That documentation can include printed documents, online documents, readme files, and help files.

See the troubleshooting information in your system documentation for instructions for using the diagnostic programs. The troubleshooting information or the diagnostic programs might tell you that you need additional or updated device drivers or other software. IBM maintains pages on the World Wide Web where you can get the latest technical information and download device drivers and updates. To access these pages, go to <http://www.ibm.com/supportportal/>.

---

## Getting help and information from the World Wide Web

Up-to-date information about IBM products and support is available on the World Wide Web.

On the World Wide Web, up-to-date information about IBM systems, optional devices, services, and support is available at <http://www.ibm.com/supportportal/>. IBM System x information is at <http://www.ibm.com/systems/x/>. IBM BladeCenter information is at <http://www.ibm.com/systems/bladecenter/>. IBM IntelliStation information is at <http://www.ibm.com/systems/intellistation/>.

---

## How to send DSA data to IBM

Use the IBM Enhanced Customer Data Repository to send diagnostic data to IBM.

Before you send diagnostic data to IBM, read the terms of use at <http://www.ibm.com/de/support/ecurep/terms.html>.

You can use any of the following methods to send diagnostic data to IBM:

- **Standard upload:** [http://www.ibm.com/de/support/ecurep/send\\_http.html](http://www.ibm.com/de/support/ecurep/send_http.html)
- **Standard upload with the system serial number:** [http://www.ecurep.ibm.com/app/upload\\_hw](http://www.ecurep.ibm.com/app/upload_hw)
- **Secure upload:** [http://www.ibm.com/de/support/ecurep/send\\_http.html#secure](http://www.ibm.com/de/support/ecurep/send_http.html#secure)
- **Secure upload with the system serial number:** [https://www.ecurep.ibm.com/app/upload\\_hw](https://www.ecurep.ibm.com/app/upload_hw)

---

## Creating a personalized support web page

You can create a personalized support web page by identifying IBM products that are of interest to you.

To create a personalized support web page, go to <http://www.ibm.com/support/mynotifications>. From this personalized page, you can subscribe to weekly email notifications about new technical documents, search for information and downloads, and access various administrative services.

---

## Software service and support

Through IBM Support Line, you can get telephone assistance, for a fee, with usage, configuration, and software problems with your IBM products.

For more information about Support Line and other IBM services, see <http://www.ibm.com/services/> or see <http://www.ibm.com/planetwide/> for support telephone numbers. In the U.S. and Canada, call 1-800-IBM-SERV (1-800-426-7378).

---

## Hardware service and support

You can receive hardware service through your IBM reseller or IBM Services.

To locate a reseller authorized by IBM to provide warranty service, go to <http://www.ibm.com/partnerworld/> and click **Business Partner Locator**. For IBM support telephone numbers, see <http://www.ibm.com/planetwide/>. In the U.S. and Canada, call 1-800-IBM-SERV (1-800-426-7378).

In the U.S. and Canada, hardware service and support is available 24 hours a day, 7 days a week. In the U.K., these services are available Monday through Friday, from 9 a.m. to 6 p.m.

---

## IBM Taiwan product service

Use this information to contact IBM Taiwan product service.

台灣 IBM 產品服務聯絡方式：  
台灣國際商業機器股份有限公司  
台北市松仁路 7 號 3 樓  
電話：0800-016-888

IBM Taiwan product service contact information:

IBM Taiwan Corporation  
3F, No 7, Song Ren Rd.  
Taipei, Taiwan  
Telephone: 0800-016-888



---

## Notices

This information was developed for products and services offered in the U.S.A.

IBM may not offer the products, services, or features discussed in this document in other countries. Consult your local IBM representative for information on the products and services currently available in your area. Any reference to an IBM product, program, or service is not intended to state or imply that only that IBM product, program, or service may be used. Any functionally equivalent product, program, or service that does not infringe any IBM intellectual property right may be used instead. However, it is the user's responsibility to evaluate and verify the operation of any non-IBM product, program, or service.

IBM may have patents or pending patent applications covering subject matter described in this document. The furnishing of this document does not give you any license to these patents. You can send license inquiries, in writing, to:

*IBM Director of Licensing*  
*IBM Corporation*  
*North Castle Drive*  
*Armonk, NY 10504-1785*  
*U.S.A.*

INTERNATIONAL BUSINESS MACHINES CORPORATION PROVIDES THIS PUBLICATION "AS IS" WITHOUT WARRANTY OF ANY KIND, EITHER EXPRESS OR IMPLIED, INCLUDING, BUT NOT LIMITED TO, THE IMPLIED WARRANTIES OF NON-INFRINGEMENT, MERCHANTABILITY OR FITNESS FOR A PARTICULAR PURPOSE. Some states do not allow disclaimer of express or implied warranties in certain transactions, therefore, this statement may not apply to you.

This information could include technical inaccuracies or typographical errors. Changes are periodically made to the information herein; these changes will be incorporated in new editions of the publication. IBM may make improvements and/or changes in the product(s) and/or the program(s) described in this publication at any time without notice.

Any references in this information to non-IBM websites are provided for convenience only and do not in any manner serve as an endorsement of those websites. The materials at those websites are not part of the materials for this IBM product, and use of those websites is at your own risk.

IBM may use or distribute any of the information you supply in any way it believes appropriate without incurring any obligation to you.

---

## Trademarks

IBM, the IBM logo, and [ibm.com](http://www.ibm.com) are trademarks of International Business Machines Corp., registered in many jurisdictions worldwide. Other product and service names might be trademarks of IBM or other companies.

A current list of IBM trademarks is available on the web at <http://www.ibm.com/legal/us/en/copytrade.shtml>.

Adobe and PostScript are either registered trademarks or trademarks of Adobe Systems Incorporated in the United States and/or other countries.

Cell Broadband Engine is a trademark of Sony Computer Entertainment, Inc., in the United States, other countries, or both and is used under license therefrom.

Intel, Intel Xeon, Itanium, and Pentium are trademarks or registered trademarks of Intel Corporation or its subsidiaries in the United States and other countries.

Java and all Java-based trademarks and logos are trademarks or registered trademarks of Oracle and/or its affiliates.

Linux is a registered trademark of Linus Torvalds in the United States, other countries, or both.

Microsoft, Windows, and Windows NT are trademarks of Microsoft Corporation in the United States, other countries, or both.

UNIX is a registered trademark of The Open Group in the United States and other countries.

---

## Important notes

Processor speed indicates the internal clock speed of the microprocessor; other factors also affect application performance.

CD or DVD drive speed is the variable read rate. Actual speeds vary and are often less than the possible maximum.

When referring to processor storage, real and virtual storage, or channel volume, KB stands for 1024 bytes, MB stands for 1,048,576 bytes, and GB stands for 1,073,741,824 bytes.

When referring to hard disk drive capacity or communications volume, MB stands for 1,000,000 bytes, and GB stands for 1,000,000,000 bytes. Total user-accessible capacity can vary depending on operating environments.

Maximum internal hard disk drive capacities assume the replacement of any standard hard disk drives and population of all hard disk drive bays with the largest currently supported drives that are available from IBM.

Maximum memory might require replacement of the standard memory with an optional memory module.

Each solid-state memory cell has an intrinsic, finite number of write cycles that the cell can incur. Therefore, a solid-state device has a maximum number of write cycles that it can be subjected to, expressed as total bytes written (TBW). A

device that has exceeded this limit might fail to respond to system-generated commands or might be incapable of being written to. IBM is not responsible for replacement of a device that has exceeded its maximum guaranteed number of program/erase cycles, as documented in the Official Published Specifications for the device.

IBM makes no representation or warranties regarding non-IBM products and services that are ServerProven, including but not limited to the implied warranties of merchantability and fitness for a particular purpose. These products are offered and warranted solely by third parties.

IBM makes no representations or warranties with respect to non-IBM products. Support (if any) for the non-IBM products is provided by the third party, not IBM.

Some software might differ from its retail version (if available) and might not include user manuals or all program functionality.

---

## Particulate contamination

**Attention:** Airborne particulates (including metal flakes or particles) and reactive gases acting alone or in combination with other environmental factors such as humidity or temperature might pose a risk to the device that is described in this document.

Risks that are posed by the presence of excessive particulate levels or concentrations of harmful gases include damage that might cause the device to malfunction or cease functioning altogether. This specification sets forth limits for particulates and gases that are intended to avoid such damage. The limits must not be viewed or used as definitive limits, because numerous other factors, such as temperature or moisture content of the air, can influence the impact of particulates or environmental corrosives and gaseous contaminant transfer. In the absence of specific limits that are set forth in this document, you must implement practices that maintain particulate and gas levels that are consistent with the protection of human health and safety. If IBM determines that the levels of particulates or gases in your environment have caused damage to the device, IBM may condition provision of repair or replacement of devices or parts on implementation of appropriate remedial measures to mitigate such environmental contamination. Implementation of such remedial measures is a customer responsibility.

*Table 17. Limits for particulates and gases*

Contaminant	Limits
Particulate	<ul style="list-style-type: none"> <li>The room air must be continuously filtered with 40% atmospheric dust spot efficiency (MERV 9) according to ASHRAE Standard 52.2<sup>1</sup>.</li> <li>Air that enters a data center must be filtered to 99.97% efficiency or greater, using high-efficiency particulate air (HEPA) filters that meet MIL-STD-282.</li> <li>The deliquescent relative humidity of the particulate contamination must be more than 60%<sup>2</sup>.</li> <li>The room must be free of conductive contamination such as zinc whiskers.</li> </ul>
Gaseous	<ul style="list-style-type: none"> <li>Copper: Class G1 as per ANSI/ISA 71.04-1985<sup>3</sup></li> <li>Silver: Corrosion rate of less than 300 Å in 30 days</li> </ul>

Table 17. Limits for particulates and gases (continued)

Contaminant	Limits
	<p><sup>1</sup> ASHRAE 52.2-2008 - <i>Method of Testing General Ventilation Air-Cleaning Devices for Removal Efficiency by Particle Size</i>. Atlanta: American Society of Heating, Refrigerating and Air-Conditioning Engineers, Inc.</p> <p><sup>2</sup> The deliquescent relative humidity of particulate contamination is the relative humidity at which the dust absorbs enough water to become wet and promote ionic conduction.</p> <p><sup>3</sup> ANSI/ISA-71.04-1985. <i>Environmental conditions for process measurement and control systems: Airborne contaminants</i>. Instrument Society of America, Research Triangle Park, North Carolina, U.S.A.</p>

---

## Documentation format

The publications for this product are in Adobe Portable Document Format (PDF) and should be compliant with accessibility standards. If you experience difficulties when you use the PDF files and want to request a web-based format or accessible PDF document for a publication, direct your mail to the following address:

*Information Development  
 IBM Corporation  
 205/A015  
 3039 E. Cornwallis Road  
 P.O. Box 12195  
 Research Triangle Park, North Carolina 27709-2195  
 U.S.A.*

In the request, be sure to include the publication part number and title.

When you send information to IBM, you grant IBM a nonexclusive right to use or distribute the information in any way it believes appropriate without incurring any obligation to you.

---

## Telecommunication regulatory statement

This product may not be certified in your country for connection by any means whatsoever to interfaces of public telecommunications networks. Further certification may be required by law prior to making any such connection. Contact an IBM representative or reseller for any questions.

---

## Electronic emission notices

When you attach a monitor to the equipment, you must use the designated monitor cable and any interference suppression devices that are supplied with the monitor.

### Federal Communications Commission (FCC) statement

**Note:** This equipment has been tested and found to comply with the limits for a Class A digital device, pursuant to Part 15 of the FCC Rules. These limits are designed to provide reasonable protection against harmful interference when the equipment is operated in a commercial environment. This equipment generates, uses, and can radiate radio frequency energy and, if not installed and used in accordance with the instruction manual, may cause harmful interference to radio communications. Operation of this equipment in a residential area is likely to cause harmful interference, in which case the user will be required to correct the interference at his own expense.

Properly shielded and grounded cables and connectors must be used in order to meet FCC emission limits. IBM is not responsible for any radio or television interference caused by using other than recommended cables and connectors or by unauthorized changes or modifications to this equipment. Unauthorized changes or modifications could void the user's authority to operate the equipment.

This device complies with Part 15 of the FCC Rules. Operation is subject to the following two conditions: (1) this device may not cause harmful interference, and (2) this device must accept any interference received, including interference that might cause undesired operation.

### Industry Canada Class A emission compliance statement

This Class A digital apparatus complies with Canadian ICES-003.

### Avis de conformité à la réglementation d'Industrie Canada

Cet appareil numérique de la classe A est conforme à la norme NMB-003 du Canada.

### Australia and New Zealand Class A statement

**Attention:** This is a Class A product. In a domestic environment this product may cause radio interference in which case the user may be required to take adequate measures.

## European Union EMC Directive conformance statement

This product is in conformity with the protection requirements of EU Council Directive 2004/108/EC on the approximation of the laws of the Member States relating to electromagnetic compatibility. IBM cannot accept responsibility for any failure to satisfy the protection requirements resulting from a nonrecommended modification of the product, including the fitting of non-IBM option cards.

**Attention:** This is an EN 55022 Class A product. In a domestic environment this product may cause radio interference in which case the user may be required to take adequate measures.

Responsible manufacturer:

International Business Machines Corp.  
New Orchard Road  
Armonk, New York 10504  
914-499-1900

European Community contact:

IBM Deutschland GmbH  
Technical Regulations, Department M372  
IBM-Allee 1, 71139 Ehningen, Germany  
Telephone: +49 7032 15 2941  
Email: lugi@de.ibm.com

## Germany Class A statement

### Deutschsprachiger EU Hinweis: Hinweis für Geräte der Klasse A EU-Richtlinie zur Elektromagnetischen Verträglichkeit

Dieses Produkt entspricht den Schutzanforderungen der EU-Richtlinie 2004/108/EG zur Angleichung der Rechtsvorschriften über die elektromagnetische Verträglichkeit in den EU-Mitgliedsstaaten und hält die Grenzwerte der EN 55022 Klasse A ein.

Um dieses sicherzustellen, sind die Geräte wie in den Handbüchern beschrieben zu installieren und zu betreiben. Des Weiteren dürfen auch nur von der IBM empfohlene Kabel angeschlossen werden. IBM übernimmt keine Verantwortung für die Einhaltung der Schutzanforderungen, wenn das Produkt ohne Zustimmung der IBM verändert bzw. wenn Erweiterungskomponenten von Fremdherstellern ohne Empfehlung der IBM gesteckt/eingebaut werden.

EN 55022 Klasse A Geräte müssen mit folgendem Warnhinweis versehen werden:

**Warnung:** Dieses ist eine Einrichtung der Klasse A. Diese Einrichtung kann im Wohnbereich Funk-Störungen verursachen; in diesem Fall kann vom Betreiber verlangt werden, angemessene Maßnahmen zu ergreifen und dafür aufzukommen.

### Deutschland: Einhaltung des Gesetzes über die elektromagnetische Verträglichkeit von Geräten

Dieses Produkt entspricht dem Gesetz über die elektromagnetische Verträglichkeit von Geräten (EMVG). Dies ist die Umsetzung der EU-Richtlinie 2004/108/EG in der Bundesrepublik Deutschland.

## **Zulassungsbescheinigung laut dem Deutschen Gesetz über die elektromagnetische Verträglichkeit von Geräten (EMVG) (bzw. der EMC EG Richtlinie 2004/108/EG) für Geräte der Klasse A**

Dieses Gerät ist berechtigt, in Übereinstimmung mit dem Deutschen EMVG das EG-Konformitätszeichen - CE - zu führen.

Verantwortlich für die Einhaltung der EMV Vorschriften ist der Hersteller:

International Business Machines Corp.  
New Orchard Road  
Armonk, New York 10504  
914-499-1900

Der verantwortliche Ansprechpartner des Herstellers in der EU ist:

IBM Deutschland GmbH  
Technical Regulations, Abteilung M372  
IBM-Allee 1, 71139 Ehningen, Germany  
Telephone: +49 7032 15 2941  
Email: lugi@de.ibm.com

### **Generelle Informationen:**

**Das Gerät erfüllt die Schutzanforderungen nach EN 55024 und EN 55022 Klasse A.**

## **Japan VCCI Class A statement**

この装置は、クラス A 情報技術装置です。この装置を家庭環境で使用すると電波妨害を引き起こすことがあります。この場合には使用者が適切な対策を講ずるよう要求されることがあります。 VCCI-A

This is a Class A product based on the standard of the Voluntary Control Council for Interference (VCCI). If this equipment is used in a domestic environment, radio interference may occur, in which case the user may be required to take corrective actions.

## Japan Electronics and Information Technology Industries Association (JEITA) statement

高調波ガイドライン準用品

Japan Electronics and Information Technology Industries Association (JEITA)  
Confirmed Harmonics Guidelines with Modifications (products greater than 20 A per phase)

## Korea Communications Commission (KCC) statement

이 기기는 업무용(A급)으로 전자파적합기기로서 판매자 또는 사용자는 이 점을 주의하시기 바라며, 가정외의 지역에서 사용하는 것을 목적으로 합니다.

This is electromagnetic wave compatibility equipment for business (Type A). Sellers and users need to pay attention to it. This is for any areas other than home.

## Russia Electromagnetic Interference (EMI) Class A statement

ВНИМАНИЕ! Настоящее изделие относится к классу А. В жилых помещениях оно может создавать радиопомехи, для снижения которых необходимы дополнительные меры

## People's Republic of China Class A electronic emission statement

声 明  
此为 A 级产品。在生活环境中，该产品可能会造成无线电干扰。在这种情况下，可能需要用户对其干扰采取切实可行的措施。

## Taiwan Class A compliance statement

警告使用者：  
這是甲類的資訊產品，在居住的環境中使用時，可能會造成射頻干擾，在這種情況下，使用者會被要求採取某些適當的對策。



---

# Index

## Numerics

4 Pac HDD option, installing 97

## A

ac good LED 29  
ac power LED 26  
accessible documentation 140  
acoustical noise emissions 6  
Active Energy Manager plug-in 10  
active memory 10  
adapter  
    remote battery  
        installing 90  
adapter, installation 70  
adapters supported 70  
administrator  
    password 119  
administrator password 113  
assistance, getting 133  
attention notices 6  
Australia Class A statement 141  
availability 14

## B

baseboard management controller 33  
bays 6  
before you install a legacy operating system 121  
blue screen capture features 10  
blue-screen capture feature  
    overview 10, 123  
Boot Manager program 111, 119  
Broadcom Gigabit Ethernet Utility program  
    enabling 126  
button, presence detection 17

## C

cables  
    connecting 109  
cabling  
    internal routing 46  
Canada Class A electronic emission statement 141  
caution statements 6  
China Class A electronic emission statement 144  
Class A electronic emission notice 141  
completing  
    options installation 106  
components  
    server 36  
configuration programs  
    LSI Configuration Utility 111  
configuring  
    with ServerGuide 121

configuring hardware 111  
connecting  
    cables 109  
connector  
    Ethernet 26  
    Ethernet systems-management 26  
    power supply 26  
    serial 26  
    USB 16, 26  
    video  
        front 16  
        rear 26  
connectors  
    external 37  
    internal 37  
    internal cable routing 46  
    option 42  
    rear 26  
contamination, particulate and gaseous 6, 139  
controllers  
    Ethernet 127  
controls and LEDs  
    on the light path diagnostics panel 18  
    on the operator information panel 17  
cooling 10  
cover  
    installing 108  
    removing 51  
creating  
    RAID array 129  
creating a personalized support web page 135  
CRUs, replacing  
    cover 108  
custom support web page 135

## D

danger statements 6  
dc good LED 29  
dc power LED 26  
dc power supply LED errors 30  
device drivers 16, 132  
devices, static-sensitive  
    handling 46  
diagnostics program  
    DSA Preboot 10  
dimension 6  
DIMM  
    installing 60  
DIMM air baffle  
    installing 107  
    removing 52  
DIMM installation sequence  
    memory mirroring 58, 60  
DIMMs  
    installing 54  
    order of installation for non-mirroring mode 57

documentation 5  
    CD 3  
    Documentation Browser 4  
    format 140  
    updates 1  
    using 134  
documentation, updated  
    finding 5  
drives 10  
    installing 62  
DSA, sending data to IBM 35, 134  
DVD  
    drive activity LED 16  
    eject button 16  
DVD drive  
    installing 66  
DVD enablement kit  
    installing 95  
Dynamic System Analysis (DSA) Preboot diagnostics program 10

## E

electrical input 6  
electronic emission Class A notice 141  
embedded hypervisor  
    using 125  
enabling 124  
enclosure management heartbeat LED 32  
Enterprise X-Architecture technology 10  
environment 6  
errors  
    dc power supply LEDs 30  
Ethernet 10  
    link status LED 26  
    systems-management connector 26  
Ethernet activity  
    LED 17, 26  
Ethernet connector 26  
Ethernet controller configuration 111  
Ethernet support 10  
European Union EMC Directive conformance statement 142  
expansion bays 6

## F

fans 10  
FCC Class A notice 141  
features 6  
    ServerGuide 120  
features, remote presence and blue-screen 10  
finding  
    updated documentation 5  
firmware updates 1, 43  
firmware, server  
    starting 119

formatting  
hard disk drive 129

## G

gaseous contamination 6, 139  
Germany Class A statement 142  
grease, thermal 105  
guidelines  
options installation 43  
system reliability 45

## H

handling static-sensitive devices 46  
hard disk drive  
formatting 129  
hard disk drive (SATA), installing  
(simple-swap 2.5-inch) 64  
hard disk drive activity LED 16  
hard disk drive status LED 16  
hard disk drive, installing (hot-swap  
2.5-inch) 62  
hard drive activity  
LED 17  
hardware  
requirements 3  
hardware service and support telephone  
numbers 135  
hardware, configuring 111  
heat output 6  
heat sink  
installing 100  
help  
from the World Wide Web 134  
from World Wide Web 134  
sending diagnostic data to IBM 35,  
134  
sources of 133  
hot-swap disk drive, installing  
2.5-inch 62  
hot-swap drive  
SAS/SATA IDs 63  
hot-swap hard disk drive cage  
installing 97  
humidity 6  
hypervisor flash device  
installing 85

## I

IBM Advanced Settings Utility program  
overview 130  
IBM Systems Director 10  
systems management tool 15  
updating 130  
IBM Taiwan product service 135  
IDs for SAS/SATA hot-swap drives 63  
IDs for SATA simple-swap drives 65  
IMM 111, 122  
IMM heartbeat  
LED 32  
IMM web interface 125  
important notices 6, 138  
IN OK LED 30  
IN OK power LED 26

information center 134  
installation guidelines 43  
installation, options  
completing 106  
installing  
2.5-inch hot-swap hard disk drive 62  
2.5-inch simple-swap SATA hard disk  
drive 64  
adapter 70  
cover 108  
DIMM 60  
DIMM air baffle 107  
DIMMs 54  
DVD drive 66  
DVD enablement kit 95  
heat sink 100  
hot-swap fan 80  
hot-swap hard disk drive cage 97  
hot-swap power supply 82  
hypervisor flash device 85  
microprocessor 100  
microprocessor 2 air baffle 106  
options 35  
RAID adapter remote battery 90  
SAS/SATA 4 Pac HDD option 97  
ServeRAID adapter advanced feature  
key 79  
simple-swap SATA hard disk  
drives 64  
two-port Ethernet adapter 87  
virtual media key 86  
installing drives 62  
instructions  
IBM Business Partners 35  
integrated functions 6  
integrated management module  
LED 32  
overview 10  
using 122  
Integrated Management Module  
programs 111  
internal cable routing 46  
internal connectors 37  
IP address  
obtaining for the IMM 124

## J

Japan Class A electronic emission  
statement 143  
Japan Electronics and Information  
Technology Industries Association  
statement 144  
JEITA statement 144

## K

key, virtual media 10  
installing 86  
Korea Class A electronic emission  
statement 144

## L

LED  
ac power 26

LED (*continued*)

dc power 26  
DVD drive activity 16  
enclosure management heartbeat 32  
Ethernet activity 17  
Ethernet-link status 26  
for Ethernet activity 26  
hard disk drive activity 16  
hard disk drive status 16  
hard drive activity 17  
IMM heartbeat 32  
IN OK power 26  
integrated management module 32  
location 16  
OUT OK power 26  
power supply error  
rear 26  
power-on 17  
rear 26  
system information 17  
system locator 17  
system-error 17  
rear 26  
system-locator  
rear 26  
LED errors  
dc power supply 30  
LEDs  
power-supply 29  
LEDs, system pulse 32  
legacy operating system  
requirement 121  
License Agreement for Machine Code 5  
Licenses and Attributions Documents 5  
light panel diagnostics panel  
location 16  
light path diagnostics 10  
LEDs 20  
light path diagnostics LEDs 20  
light path diagnostics panel  
controls and LEDs 18  
NMI button 18  
local area network (LAN) 10  
log on 125  
LSI Configuration Utility program  
starting 128  
using 127

## M

management, system 10  
memory 10  
specifications 6  
two-DIMM-per-channel (2DPC) 54  
memory installation sequence  
non-mirroring mode 57  
memory mirroring  
description 58  
DIMM population sequence 58, 60  
memory online-spare  
description 60  
memory support 10  
menu choices  
Setup utility 113  
microprocessor 10  
installing 100  
specifications 6

- microprocessor 2 air baffle
  - installing 106
  - removing 53
- mirroring mode 58

## N

- New Zealand Class A statement 141
- NMI button
  - on the light path diagnostics panel 18
- NOS installation
  - ServerGuide 121
  - without ServerGuide 122
- notes 6
- notes, important 138
- notices 137
  - electronic emission 141
  - FCC, Class A 141
- notices and statements 6

## O

- obtaining
  - IP address for IMM 124
- online documentation 1
- online publications 5
- online-spare mode 60
- operator information panel
  - controls and LEDs 17
- operator information panel release latch 16
- optional optical drive
  - specifications 6
- options
  - installing 35
- OUT OK LED 30
- OUT OK power LED 26

## P

- particulate contamination 6, 139
- password 116
  - administrator 116
  - power-on 116
- password, power-on
  - switch on system board 117
- PCI
  - slot 1 26
  - slot 2 26
- PCI expansion slots 6
- PCI Express riser-card assembly
  - replacing with a PCI-X riser-card assembly 73
- PCI riser slots
  - installation configurations 70
  - supported configurations 70
- PCI riser-card assembly
  - replacing 68
- PCI-X riser-card assembly
  - replacing with a PCI Express riser-card assembly 74
- People's Republic of China Class A electronic emission statement 144
- power
  - power-control button 17

- power (*continued*)
  - power-on LED 33
  - server 33
  - specifications 6
  - supply 6
- power on and working inside the server 45
- power supply
  - installing 82
- power-on
  - LED
    - rear 26
  - power-on LED 17
  - power-on password 113
- power-supply
  - LEDs 29
- power-supply LEDs 29
  - AC 29
- presence detection button 17
- product service, IBM Taiwan 135

## R

- rack release latches 16
- RAID array
  - creating 129
- RAID controller
  - removing 75
- RAS features 14
- rear view 26
- redundant
  - cooling 10
  - Ethernet connection 10
  - NIC 10
- Redundant
  - Ethernet capabilities 14
  - hot-swap power supplies 14
- reliability 14
- remind button 18
- remote battery, RAID adapter
  - installing 90
- remote presence feature 10, 124
  - using 123
- Remote presence support 111
- removing
  - DIMM air baffle 52
  - microprocessor 2 air baffle 53
  - RAID controller 75
  - SAS/SATA controller 75
- replacing
  - PCI riser-card assembly 68
- replacing a PCI Express riser-card assembly
  - with a PCI-X riser-card assembly 73
- replacing a PCI-X riser-card assembly
  - with a PCI Express riser-card assembly 74
- reset button 18
- riser card
  - connector location 37
- Russia Class A electronic emission statement 144

## S

- safety v
- Safety Information 6
- safety statements v, vii
- SAS/SATA
  - IDs for hot-swap drives 63
- SAS/SATA 4 Pac HDD option,
  - installing 97
- SAS/SATA controller
  - removing 75
- SATA
  - IDs for simple-swap drives 65
- sending diagnostic data to IBM 35, 134
- serial connector 26
- serial number 1
- server
  - offerings 10
  - working inside with the power on 45
- Server
  - power features 33
  - server components 36
  - server configuration
    - updating 110
  - server, backup firmware
    - starting 119
  - ServeRAID adapter
    - removing 75
  - ServeRAID adapter advanced feature key
    - installing 79
  - ServeRAID support 10
  - ServerGuide
    - features 120
    - NOS installation 121
    - setup 121
    - using 120
  - ServerGuide CD 1, 10
  - service and support
    - before you call 133
    - hardware 135
    - software 135
  - serviceability 14
  - Setup utility 111, 112
    - menu choices 113
    - starting 113
    - using 112
  - shutdown 33
  - simple-swap drive
    - SATA IDs 65
  - simple-swap front view
    - LED location 16
  - simple-swap SATA disk drive (e.5-inch),
    - installing 64
  - simple-swap SATA hard disk drives
    - installing 64
  - size 6
  - slots
    - PCI expansion 6
  - SMP 10
  - software
    - requirements 3
  - software service and support telephone numbers 135
  - specifications 6
  - standby mode 33

- starting
    - LSI Configuration Utility
      - program 128
      - server firmware 119
      - Setup utility 113
  - statements and notices 6
  - static-sensitive devices
    - handling 46
  - support web page, custom 135
  - SW3 switch block description 38
  - SW4 switch block description 38
  - switch block
    - system board 38
  - switches and jumpers
    - system board 38
  - symmetric multiprocessing 10
  - system
    - error LED front 17
    - locator LED front 17
    - system-error LED
      - rear 26
  - System
    - information LED 17
  - system board
    - internal connectors 37
    - power-on password switch 117
    - switches and jumpers 38
  - system pulse LEDs 32
  - system reliability guidelines 45
  - system-board LEDs 41
  - system-locator
    - LED
      - rear 26
  - systems management 10
  - systems management tool
    - IBM Systems Director 15
  - systems-management
    - Ethernet connector 26
- using
    - embedded hypervisor 125
    - IMM 122
    - integrated management module 122
    - LSI Configuration Utility
      - program 127
      - remote presence feature 123
      - Setup utility 112
  - utility
    - Setup 112
  - Utility program
    - IBM Advanced Settings 130
  - utility, Setup 111

## V

- video connector
  - front 16
  - rear 26
- video controller, integrated
  - specifications 6
- virtual media key
  - installing 86
- virtual media key, support 10
- VMware Hypervisor support 111

## W

- Wake on LAN feature 33
- weight 6
- what the server offers 10
- working inside the server
  - power on 45

## X

- X-Architecture technology 10

## T

- Taiwan Class A electronic emission
  - statement 145
- telecommunication regulatory
  - statement 140
- telephone numbers 135
- temperature 6
- thermal grease 105
- TOE 6
- trademarks 138
- turning off the server 33
  - baseboard management controller 33
- turning on the server 33
- two-DIMM-per-channel (2DPC)
  - requirements 54

## U

- United States FCC Class A notice 141
- UpdateXpress 16, 132
- updating
  - IBM Systems Director 130
  - server configuration 110
  - Systems Director, IBM 130
- USB
  - connector 16, 26





Part Number: 00KC032

Printed in USA

(1P) P/N: 00KC032

