

lenovo

ThinkStation
User Guide



ThinkThink**ThinkStation**Think

Machine Types: 4262, 4263, 4264, 4265, 4266, 4269, 4271, and 4272

Note: Before using this information and the product it supports, be sure to read and understand the *ThinkStation Safety and Warranty Guide* and Appendix B “Notices” on page 73.

Fourth Edition (June 2012)

© Copyright Lenovo 2010, 2012.

LIMITED AND RESTRICTED RIGHTS NOTICE: If data or software is delivered pursuant a General Services Administration “GSA” contract, use, reproduction, or disclosure is subject to restrictions set forth in Contract No. GS-35F-05925.

Contents

Important safety information	iii	Using the Rescue and Recovery workspace	44
Chapter 1. Product overview	1	Creating and using a rescue medium	45
Features	1	Creating a rescue medium	45
Specifications	3	Using a rescue medium	45
Software overview	4	Installing or reinstalling device drivers	46
Software provided with your Windows operating system	4	Solving recovery problems	46
Locating computer controls, connectors, and parts	6	Chapter 4. Using the Setup Utility program	49
Locating controls and connectors on the front of your computer	6	Starting the Setup Utility program	49
Locating connectors on the rear of your computer	7	Viewing or changing settings	49
Locating components	8	Using passwords.	49
Locating parts and connectors on the system board	9	Password considerations.	50
Chapter 2. Installing or replacing hardware	13	Administrator password	50
Installing or replacing hardware	13	User Password.	50
Installing external options	13	Setting, changing, or deleting a password	50
Removing the computer cover.	13	Enabling or disabling a device	50
Removing and reinstalling the front bezel	14	Selecting a startup device	51
Removing and reinstalling the PCI card holder	15	Selecting a temporary startup device	51
Installing or replacing a memory module.	17	Viewing or changing the startup device sequence	51
Installing or replacing a PCI card	21	Advanced settings	52
Installing a new hard disk drive	23	Exiting the Setup Utility program	52
Replacing a hard disk drive	26	Chapter 5. Configuring RAID	53
Replacing the optical drive	27	Configuring RAID for machine types 4262, 4263, 4264, and 4265	53
Replacing the heat sink and fan assembly	29	Installing SATA hard disk drives	53
Replacing the front fan assembly	32	Configuring the system BIOS to enable SATA RAID functionality.	53
Replacing the rear fan assembly	34	Creating RAID volumes	54
Replacing the keyboard or mouse	36	Deleting RAID volumes	54
Completing the parts replacement	37	Configuring RAID for machine types 4266, 4269, 4271, and 4272	54
Obtaining device drivers	38	Installing SATA or SAS hard disk drives	55
Basic security features	38	Entering the Marvell BIOS Setup to configure SATA or SAS RAID	55
Locking devices	39	Configuring the Marvell BIOS Setup to enable SATA/SAS RAID 0, 1, or 5 functionality	55
Password protection	40	Configuring the Marvell BIOS Setup to set an optional hot spare hard disk drive	56
Chapter 3. Recovery information	41	Configuring the Marvell BIOS Setup to delete an optional hot spare hard disk drive	56
Creating and using recovery media	41	Configuring the Marvell BIOS Setup to delete an array	56
Creating recovery media	41	Chapter 6. Updating system programs	57
Using recovery media	41	Using system programs	57
Performing backup and recovery operations	42		
Performing a backup operation	43		
Performing a recovery operation	43		

Updating (flashing) the BIOS from a disc	57
Updating (flashing) the BIOS from your operating system	58
Recovering from a POST/BIOS update failure	58

Chapter 7. Troubleshooting and diagnostic programs 61

Basic troubleshooting	61
Diagnostic programs	62
Lenovo Solution Center	62
Lenovo ThinkVantage Toolbox	62
PC-Doctor for Rescue and Recovery	63
PC-Doctor for DOS	63
Cleaning an optical mouse	64

Chapter 8. Getting information, help, and service 65

Information resources	65
Online Books folder	65
Lenovo ThinkVantage Tools	65
Lenovo Welcome	65
Safety and warranty	66
Lenovo Web site	66
Lenovo Support Web site	66
Help and service	66
Using the documentation and diagnostic programs	66
Calling for service	67

Using other services	67
Purchasing additional services	68

Appendix A. System memory speed . 69

Appendix B. Notices 73

Television output notice	74
European conformance CE mark	74
Trademarks	74

Appendix C. WEEE and recycling information 75

Important WEEE Information	75
Recycling information	75
Recycling information for Brazil	76
Battery recycling information for Taiwan	76
Battery recycling information for the European Union	77

Appendix D. Restriction of Hazardous Substances Directive (RoHS) 79

China RoHS	79
Turkish RoHS	79
Ukraine RoHS	79
India RoHS	80

Index 81

Important safety information

CAUTION:

Before using this manual, be sure to read and understand all the related safety information for this product. Refer to the *ThinkStation Safety and Warranty Guide* that you received with this product for the latest safety information. Reading and understanding this safety information reduces the risk of personal injury and or damage to your product.

If you no longer have a copy of the *ThinkCentre Safety and Warranty Guide*, you can obtain a Portable Document Format (PDF) version from the Lenovo® Support Web site at <http://support.lenovo.com>.

Chapter 1. Product overview

This chapter provides information about the computer features, specifications, preinstalled software programs, and connector and part locations.

This chapter contains the following topics:

- “Features” on page 1: This section provides information about the computer features.
- “Specifications” on page 3: This section lists the physical specifications for your computer.
- “Software overview” on page 4: This section provides information about the software programs provided with your computer.
- “Locating computer controls, connectors, and parts” on page 6: This section provides information to help you locate your computer controls, connectors, and parts.

Features

This section provides information about the computer features.

System information

The following information covers a variety of models. For information about your specific model, use the Setup Utility program. See Chapter 4 “Using the Setup Utility program” on page 49.

Microprocessor

Your computer comes with one of the following microprocessors (internal cache size varies by model type):

- Intel® Xeon® Dual Core microprocessor
- Intel Xeon Quad Core microprocessor
- Intel Xeon Six Core microprocessor

Memory module(s)

- Supports up to six or 12 double data rate 3 dual inline memory modules (DDR3 DIMMs)
- Each microprocessor supports up to three or six memory modules

Note: The Intel Xeon microprocessor families compatible with this ThinkStation™ computer feature an integrated memory controller, which provides the microprocessor with direct access to the system memory. Because of this design, the system memory speed will be determined by a number of factors, including the microprocessor model and the type, speed, size (capacity), and number of DIMMs installed. Refer to Appendix A “System memory speed” on page 69 for the information on the supported system memory speed for your computer model.

Internal drives

- One Serial Advanced Technology Attachment (SATA) optical drive
- Three SATA hard disk drives or Serial Attached SCSI (SAS) hard disk drives

Video subsystem

- Two Peripheral Component Interconnect (PCI) Express x16 card slots on the system board for discrete graphics cards (varies by model type)

Audio subsystem

- Integrated high-definition (HD) audio
- Microphone connector and headphone connector on the front panel
- Eight audio connectors on the rear panel
 - Audio line-in connector
 - Audio line-out front speaker connector
 - Audio line-out rear speaker connector
 - Audio line-out side speaker connector
 - Audio line-out subwoofer/center speaker connector
 - Microphone connector
 - Optical Sony Philips Digital Interconnect Format (SPDIF) in connector
 - Optical SPDIF out connector
- Internal speakers

Connectivity

- One or two 10/100/1000 Mbps Ethernet controller(s)

System management features

- Ability to store the power-on self-test (POST) hardware test results
- Advanced Configuration and Power Interface (ACPI) support
- Alert Standard Format (ASF) 2.0
- Automatic power-on startup
- Preboot Execution Environment (PXE)
- System Management (SM) Basic Input/Output System (BIOS) and SM software
- Wake on LAN
- Wake on Ring (in the Setup Utility program, this feature is called Serial Port Ring Detect for an external modem)
- Windows Management Instrumentation (WMI)

Input/Output (I/O) features

- 9-pin serial port (available on some models)
- 10 USB (Universal Serial Bus) connectors
- Eight audio connectors on the rear panel
- One external Serial Advanced Technology Attachment (eSATA) connector
- One or two Ethernet connector(s)
- Two audio connectors on the front panel (microphone connector and headphone connector)
- Two IEEE 1394 connectors (available on some models)

For more information about I/O features, see “Locating connectors on the rear of your computer” on page 7.

Expansion

- One optical drive bay
- One PCI Express x1 card slot

- One PCI Express x4 card slot (x16 mechanical)
- Three hard disk drives
- Two PCI card slots
- Two PCI Express x16 card slots

Power supply

- 800-watt auto-sensing power supply

Security features

- Cover presence switch (also called intrusion switch) (available in some models)
- Enabling or disabling SATA devices
- Enabling or disabling the serial port
- Enabling or disabling USB connectors individually
- User password and administrator password to deter unauthorized use of your computer
- Startup sequence control
- Startup without keyboard or mouse
- Support for a keylock
- Support for the addition of a padlock
- Support for the addition of an integrated cable lock (Kensington lock)
- Trusted Platform Module (TPM)

Preinstalled software programs

Your computer is preinstalled with some software programs to help you work more easily and securely. For more information, see “Software overview” on page 4.

Preinstalled operating system

Your computer is preinstalled with one of the following operating systems:

- Microsoft® Windows® 7
- Microsoft Windows XP Professional (preinstalled through downgrade rights in Windows 7 Professional)

Operating system(s), certified or tested for compatibility¹ (varies by model type)

- Linux®

Specifications

This section lists the physical specifications for your computer.

1. The operating system(s) listed here are being certified or tested for compatibility at the time this publication goes to press. Additional operating systems might be identified by Lenovo as compatible with your computer following the publication of this manual. This list is subject to change. To determine if an operating system has been certified or tested for compatibility, check the Web site of the operating system vendor.

Dimensions

Width: 130 mm (5.12 inches)

Height: 427 mm (16.81 inches)

Depth: 444 mm (17.48 inches)

Weight

Maximum configuration: 18.5 kg (40.8 lbs)

Environment

- Air temperature:
 - Operating: 10°C to 35°C (50°F to 95°F)
 - Storage: -10°C to 60°C (14°F to 140°F) without package
- Humidity:
 - Operating: 10% to 80% (10% per hour, non-condensing)
 - Storage: 10% to 90% (10% per hour, non-condensing)
- Maximum altitude: 7 000 ft (2 133.6 m)

Electrical input

- Input voltage:
 - Low range:
 - Minimum: 100 V ac
 - Maximum: 127 V ac
 - Input frequency range: 50 to 60 Hz
 - High range:
 - Minimum: 200 V ac
 - Maximum: 240 V ac
 - Input frequency range: 50 to 60 Hz

Software overview

The computer comes with a preinstalled operating system and several preinstalled applications.

Software provided with your Windows operating system

This section provides information about the software provided with your Windows operating system.

Software provided by Lenovo

The following software programs are provided by Lenovo to help you improve productivity and reduce the cost associated with maintaining your computer. Software programs provided with your computer might vary depending on your model type and preinstalled operating system.

Notes: The following software programs are supported on your ThinkStation computer. You can find detailed information and download the software programs from the Lenovo Support Web site at: <http://support.lenovo.com>

- ThinkVantage Productivity Center
- ThinkVantage Client Security Solution (CSS)
- ThinkVantage System Update (TVSU)

Lenovo ThinkVantage Tools

The Lenovo ThinkVantage® Tools program guides you to a host of information sources and provides easy access to various tools to help you work more easily and securely. For more information, see “Lenovo ThinkVantage Tools” on page 65.

Note: The Lenovo ThinkVantage Tools program is only available on computers with the Windows 7 operating system from Lenovo.

Lenovo Welcome

The Lenovo Welcome program introduces some innovative built-in features of Lenovo to you and guides you through some important setup tasks to help you make the most of your computer.

Note: The Lenovo Welcome program is only available on computers preinstalled with the Windows 7 operating system from Lenovo.

Product Recovery

The Product Recovery program enables you to restore the contents of the hard disk drive to the factory default settings.

ThinkVantage Rescue and Recovery

The ThinkVantage Rescue and Recovery program is a one button recovery and restore solution that includes a set of self-recovery tools to help you diagnose computer problems, get help, and recover from system crashes, even if you cannot start the Windows operating system.

Lenovo Solution Center

Note: Depending on the date when your computer was manufactured, your computer is preinstalled with either the Lenovo Solution Center program or the Lenovo ThinkVantage Toolbox program for diagnostic purposes. For additional information about the Lenovo ThinkVantage Toolbox program, see “Lenovo ThinkVantage Toolbox” on page 62.

The Lenovo Solution Center program enables you to troubleshoot and resolve computer problems. It combines diagnostic tests, system information collection, security status, and support information, along with hints and tips for maximum system performance. See “Lenovo Solution Center” on page 62 for detailed information.

Lenovo ThinkVantage Toolbox

Note: Depending on the date when your computer was manufactured, your computer is preinstalled with either the Lenovo Solution Center program or the Lenovo ThinkVantage Toolbox program for diagnostic purposes. For additional information about the Lenovo Solution Center program, see “Lenovo Solution Center” on page 62.

The Lenovo ThinkVantage Toolbox program helps you maintain your computer, improve computing security, diagnose computer problems, get familiar with the innovative technologies provided by Lenovo, and get more information about your computer. For more information, see “Lenovo ThinkVantage Toolbox” on page 62.

PC-Doctor for Rescue and Recovery

The PC-Doctor for Rescue and Recovery diagnostic program is preinstalled on your ThinkStation computer as part of the Rescue and Recovery workspace to help you diagnose hardware problems. It can also report operating-system-controlled settings that interfere with the correct operation of your system. Use the PC-Doctor for Rescue and Recovery diagnostic program if you are unable to start the Windows operating system. For more information, see “PC-Doctor for Rescue and Recovery” on page 63.

Adobe Reader

The Adobe Reader program is a tool used to view, print, and search PDF documents.

See “Online Books folder” on page 65 for more information about accessing and viewing the publications.

Antivirus software

Your computer comes with antivirus software that you can use to detect and eliminate viruses. Lenovo provides a full version of antivirus software on your computer with a free 30-day subscription. After 30 days, you must renew the license to continue receiving the antivirus software updates.

For more information about how to use your antivirus software, refer to the help system of your antivirus software.

Locating computer controls, connectors, and parts

This section provides information to help you locate your computer controls, connectors, and parts.

Locating controls and connectors on the front of your computer

Figure 1 “Front control and connector locations” on page 6 shows the locations of the controls and connectors on the front of your computer.

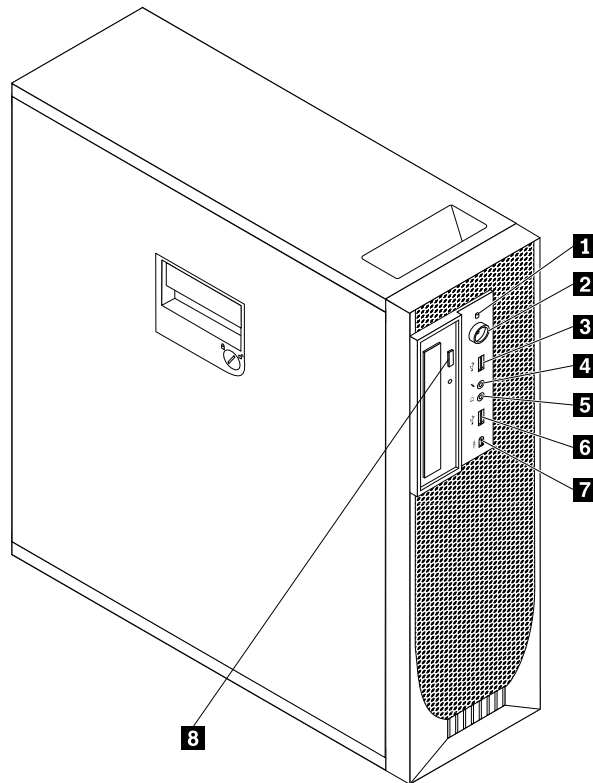

Figure 1. Front control and connector locations

- | | |
|---|---|
| 1 Hard disk drive activity indicator | 5 Headphone connector |
| 2 Power switch and power indicator | 6 USB connector |
| 3 USB connector | 7 IEEE 1394 connector (available on some models) |
| 4 Microphone connector | 8 Optical drive eject button |

Locating connectors on the rear of your computer

Figure 2 “Rear connector locations” on page 7 shows the locations of the connectors on the rear of your computer. Some connectors on the rear of your computer are color-coded to help you determine where to connect the cables on your computer.

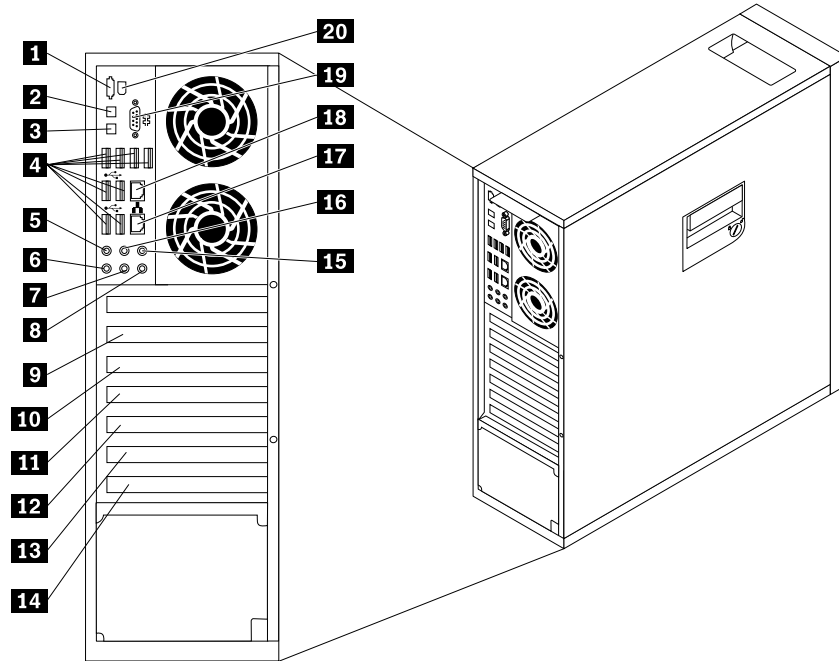

Figure 2. Rear connector locations

- | | |
|---|---|
| 1 eSATA connector | 11 PCI card slot cover |
| 2 Optical SPDIF in connector | 12 PCI Express x16 card slot cover |
| 3 Optical SPDIF out connector | 13 PCI Express x4 card slot cover |
| 4 USB connectors (8) | 14 PCI card slot cover |
| 5 Audio line-out side speaker connector | 15 Audio line-out subwoofer/center speaker connector |
| 6 Microphone connector | 16 Audio line-out rear speaker connector |
| 7 Audio line-out front speaker connector | 17 Ethernet connector (available on some models) |
| 8 Audio line-in connector | 18 Ethernet connector |
| 9 PCI Express x1 card slot cover | 19 Serial port (available on some models) |
| 10 PCI Express x16 card slot cover | 20 IEEE 1394 connector (available on some models) |

Connector	Description
Audio line-in connector	Used to receive audio signals from an external audio device, such as a stereo system. When you attach an external audio device, a cable is connected between the audio line-out connector of the device and the audio line-in connector of the computer.
Audio line-out connector (front speaker connector)	Used to send audio signals from the computer to external devices, such as powered stereo speakers (speakers with built-in amplifiers), multimedia keyboards, or the audio line-in connector on a stereo system or other external recording devices. When used with 5.1 or 7.1 surround-sound speakers, this connector should be attached to the front left and right speakers.
Audio line-out connector (rear speaker connector)	When used with 5.1 or 7.1 surround-sound speakers, this connector should be attached to the rear left and right speakers.
Audio line-out connector (side speaker connector)	When used with 7.1 surround-sound speakers, this connector should be attached to the side left and right speakers.
Audio line-out connector (subwoofer/center speaker connector)	When used with 5.1 or 7.1 surround-sound speakers, this connector should be attached to the center speaker or subwoofer.
eSATA connector	Use this connector to attach an external hard disk drive.
Ethernet connector	Used to attach an Ethernet cable for a local area network (LAN). Notes: <ol style="list-style-type: none"> 1. To operate the computer within FCC Class B limits, use a Category 5 Ethernet cable. 2. If your computer has two Ethernet connectors, it is recommended that you connect your primary Ethernet cable to the Ethernet connector marked as number "1" for optimal performance.
IEEE 1394 connector (available on some models)	Used to send and receive IEEE 1394 signals between the computer and a compliant device, such as a video camera or external storage drive. This connector is sometimes called FireWire because it transmits data rapidly.
Microphone connector	Used to attach a microphone to your computer when you want to record sound or if you use speech-recognition software.
Optical SPDIF in connector	Used to receive 5.1 digital audio signals from an external device (such as a receiver or a multimedia device) through a TOSLINK (ToshibaLink) optical cable.
Optical SPDIF out connector	Used to send 5.1 digital audio signals from a computer to an external device (such as an amplifier or a receiver) through a TOSLINK optical cable.
Serial port (available on some models)	Used to attach an external modem, a serial printer, or other devices that use a 9-pin serial port.
USB connector	Used to attach a device that uses a USB connector, such as a USB keyboard, a USB mouse, a USB scanner, or a USB printer. If the USB connectors on your computer are not enough for you to connect all your USB devices, you can purchase a USB hub, which you can use to connect additional USB devices.

Locating components

Figure 3 “Component locations” on page 9 shows the locations of the various components in your computer. To remove the computer cover and access the inside of the computer, see “Removing the computer cover” on page 13.

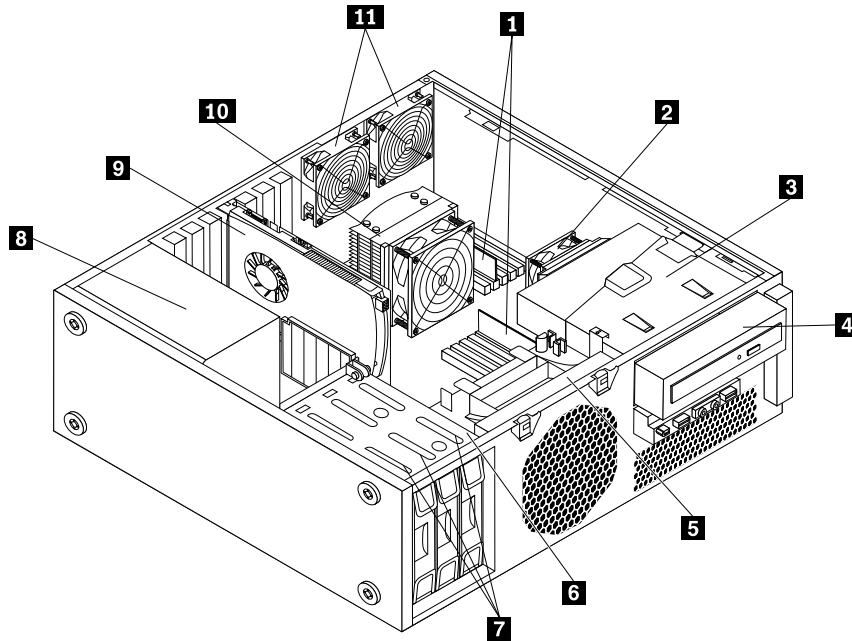

Figure 3. Component locations

- | | |
|---------------------------------------|--|
| 1 Memory modules | 7 Hard disk drives (3) |
| 2 Heat sink and fan assembly 2 | 8 Power supply assembly |
| 3 Optical drive bracket | 9 PCI card |
| 4 Optical drive | 10 Heat sink and fan assembly 1 |
| 5 Front fan assembly bracket | 11 Rear fan assemblies (2) |
| 6 Hard disk drive bay | |

Locating parts and connectors on the system board

Note: Your computer comes with one of the following system boards.

Figure 4 “System board part and connector locations” on page 10 shows the locations of the parts and connectors on one type of system board.

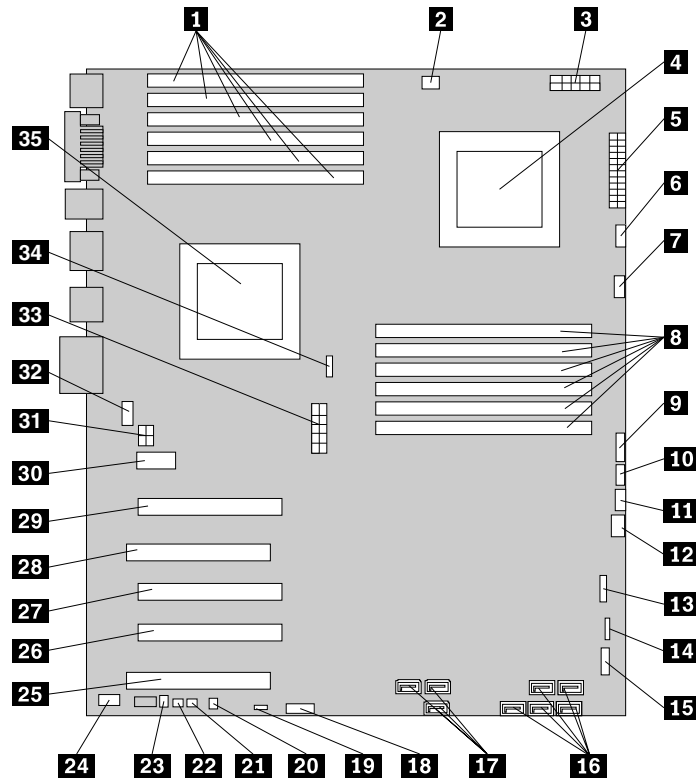

Figure 4. System board part and connector locations

- | | |
|--|---|
| 1 CPU 1 memory slots (6) | 19 Clear Complementary Metal Oxide Semiconductor (CMOS) /Recovery jumper |
| 2 CPU 1 memory fan connector | 20 Thermal sensor connector |
| 3 CPU 2 12 V power connector | 21 Cover presence switch connector |
| 4 Microprocessor 2 | 22 Personal System/2 (PS/2) keyboard and mouse connector |
| 5 24-pin power connector | 23 Internal speaker connector |
| 6 CPU 2 fan connector | 24 Front audio connector |
| 7 CPU 2 memory fan connector | 25 PCI card slot |
| 8 CPU 2 memory slots (6) | 26 PCI Express x4 card slot (x16 mechanical) |
| 9 Power switch and LEDs connector | 27 PCI Express x16 card slot |
| 10 Auxiliary LED connector | 28 PCI card slot |
| 11 Right rear fan connector | 29 PCI Express x16 card slot |
| 12 Front fan connector | 30 PCI Express x1 card slot |
| 13 Card reader connector | 31 Auxiliary 12 V power connector |
| 14 Front USB connector | 32 Left rear fan connector |
| 15 Front IEEE 1394 connector | 33 CPU 1 12 V power connector |
| 16 Hard disk drive connectors (5) | 34 CPU 1 fan connector |
| 17 Optical drive connectors (3) | 35 Microprocessor 1 |
| 18 Battery | |

Figure 5 “System board part and connector locations” on page 11 shows the locations of the parts and connectors on the other type of system board.

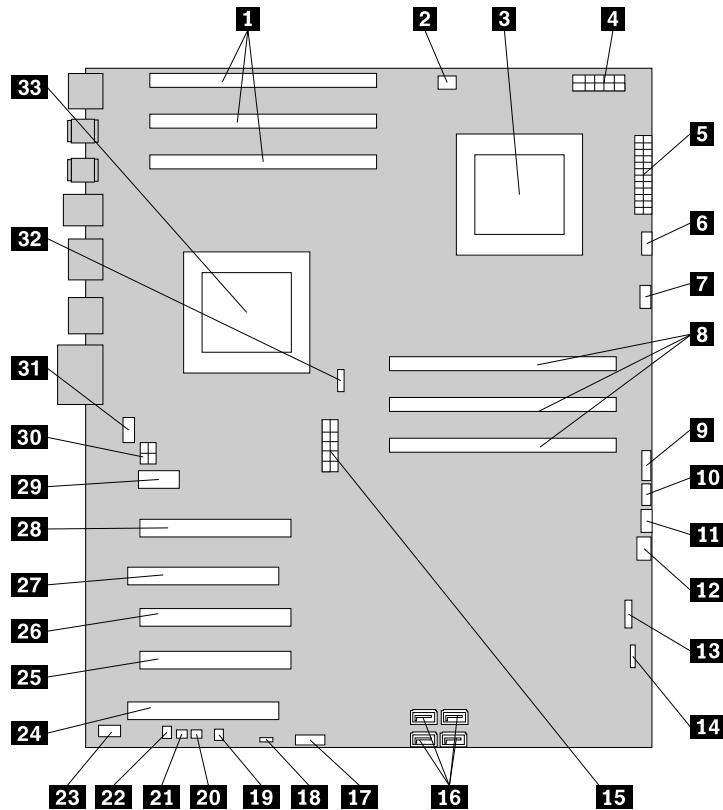

Figure 5. System board part and connector locations

- | | |
|--|---|
| 1 CPU 1 memory slots (3) | 18 Clear Complementary Metal Oxide Semiconductor (CMOS) /Recovery jumper |
| 2 CPU 1 memory fan connector | 19 Thermal sensor connector |
| 3 Microprocessor 2 | 20 Cover presence switch connector |
| 4 CPU 2 12 V power connector | 21 PS/2 keyboard and mouse connector |
| 5 24-pin power connector | 22 Internal speaker connector |
| 6 CPU 2 fan connector | 23 Front audio connector |
| 7 CPU 2 memory fan connector | 24 PCI card slot |
| 8 CPU 2 memory slots (3) | 25 PCI Express x4 card slot (x16 mechanical) |
| 9 Power switch and LEDs connector | 26 PCI Express x16 card slot |
| 10 Auxiliary LED connector | 27 PCI card slot |
| 11 Right rear fan connector | 28 PCI Express x16 card slot |
| 12 Front fan connector | 29 PCI Express x1 card slot |
| 13 Card reader connector | 30 Auxiliary 12 V power connector |
| 14 Front USB connector | 31 Left rear fan connector |
| 15 CPU 1 12 V power connector | 32 CPU 1 fan connector |

16 SATA connectors (4)

17 Battery

33 Microprocessor 1

Chapter 2. Installing or replacing hardware

This chapter provides instructions on how to install or replace hardware for your computer.

This chapter contains the following topics:

- “Installing or replacing hardware” on page 13
- “Obtaining device drivers” on page 38
- “Basic security features” on page 38

Installing or replacing hardware

This section provides instructions on how to install or replace hardware for your computer. You can maintain your computer or expand the capabilities of your computer by installing or replacing hardware.

Notes:

1. Use only computer parts provided by Lenovo.
2. When installing or replacing an option, use the appropriate instructions in this section along with the instructions that come with the option.

Installing external options

You can install external options to your computer, such as external speakers, a printer, or a scanner. For some external options, you must install additional software in addition to making the physical connection. When you install an external option, see “Locating computer controls, connectors, and parts” on page 6 to identify the required connector. Then, use the instructions that come with the option to help you make the connection and install any software or device drivers that are required for the option.

Removing the computer cover

Attention:

Do not open your computer or attempt any repair before reading and understanding the “Important safety information” in the *ThinkStation Safety and Warranty Guide* that came with your computer. To obtain a copy of the *ThinkStation Safety and Warranty Guide*, go to:
<http://support.lenovo.com>

This section provides instructions on how to remove the computer cover.

CAUTION:

The heat sink and fan assembly might be very hot. Turn off the computer and wait three to five minutes to let the computer cool before removing the computer cover.

To remove the computer cover, do the following:

1. Remove all media from the drives and turn off all attached devices and the computer. Then, disconnect all power cords from electrical outlets and disconnect all cables that are connected to the computer.

2. Use the keys that came with your computer to unlock the keylock **1** in the computer cover. Press the computer cover-release button **2** and then remove the computer cover. Place the computer cover on a flat surface.

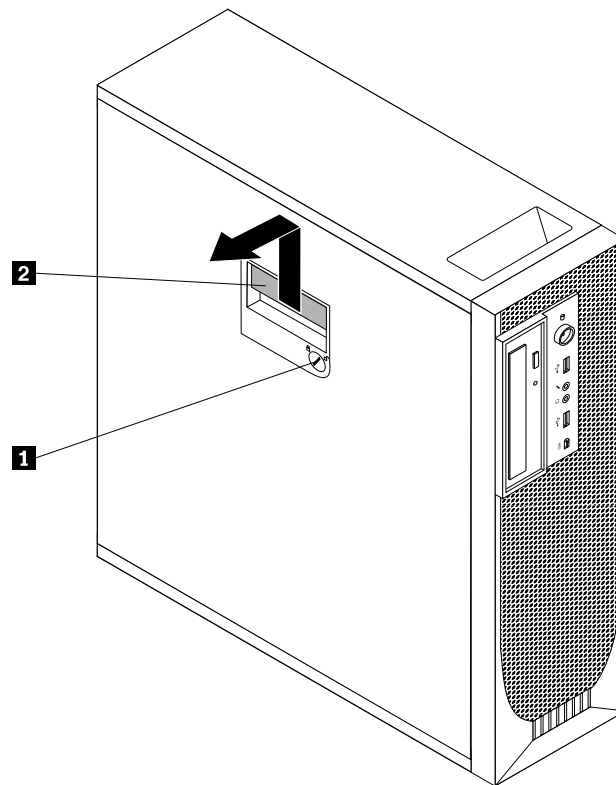

Figure 6. Removing the computer cover

Removing and reinstalling the front bezel

Attention:

Do not open your computer or attempt any repair before reading and understanding the “Important safety information” in the *ThinkStation Safety and Warranty Guide* that came with your computer. To obtain a copy of the *ThinkStation Safety and Warranty Guide*, go to:
<http://support.lenovo.com>

This section provides instructions on how to remove and reinstall the front bezel.

To remove and reinstall the front bezel, do the following:

1. Remove all media from the drives and turn off all attached devices and the computer. Then, disconnect all power cords from electrical outlets and disconnect all cables that are connected to the computer.
2. Remove the computer cover. See “Removing the computer cover” on page 13.

3. Remove the front bezel by releasing the two plastic tabs on the left side and pivoting the front bezel outward.

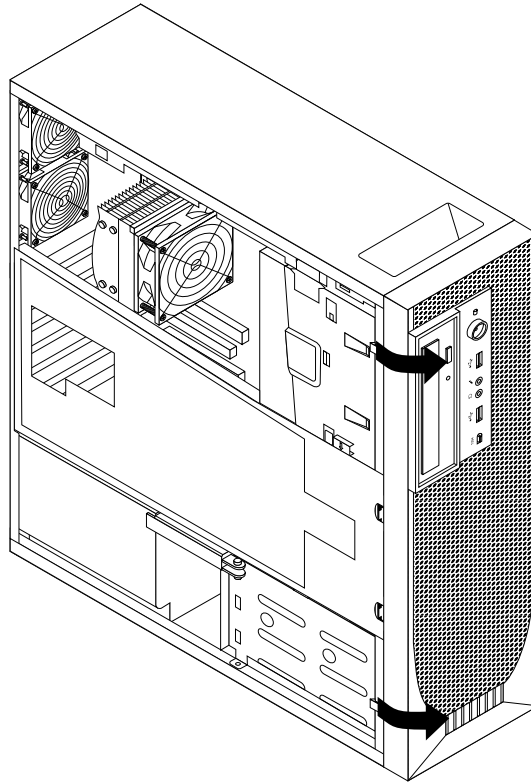

Figure 7. Removing the front bezel

4. Lay the front bezel on a flat surface.
5. To reinstall the front bezel, align the other three plastic tabs on the right side of the front bezel with the corresponding holes in the chassis, then pivot the front bezel inward until it snaps into position.

Removing and reinstalling the PCI card holder

Attention:

Do not open your computer or attempt any repair before reading and understanding the “Important safety information” in the *ThinkStation Safety and Warranty Guide* that came with your computer. To obtain a copy of the *ThinkStation Safety and Warranty Guide*, go to:
<http://support.lenovo.com>

This section provides instructions on how to remove and reinstall the PCI card holder.

To remove and reinstall the PCI card holder, do the following:

1. Remove all media from the drives and turn off all attached devices and the computer. Then, disconnect all power cords from electrical outlets and disconnect all cables that are connected to the computer.
2. Remove the computer cover. See “Removing the computer cover” on page 13.
3. Remove the front bezel. See “Removing and reinstalling the front bezel” on page 14.
4. Lay the computer on its side.

5. Press the two tabs **1** that secure the PCI card holder **2** inward, and then pivot the card holder to remove it from the chassis.

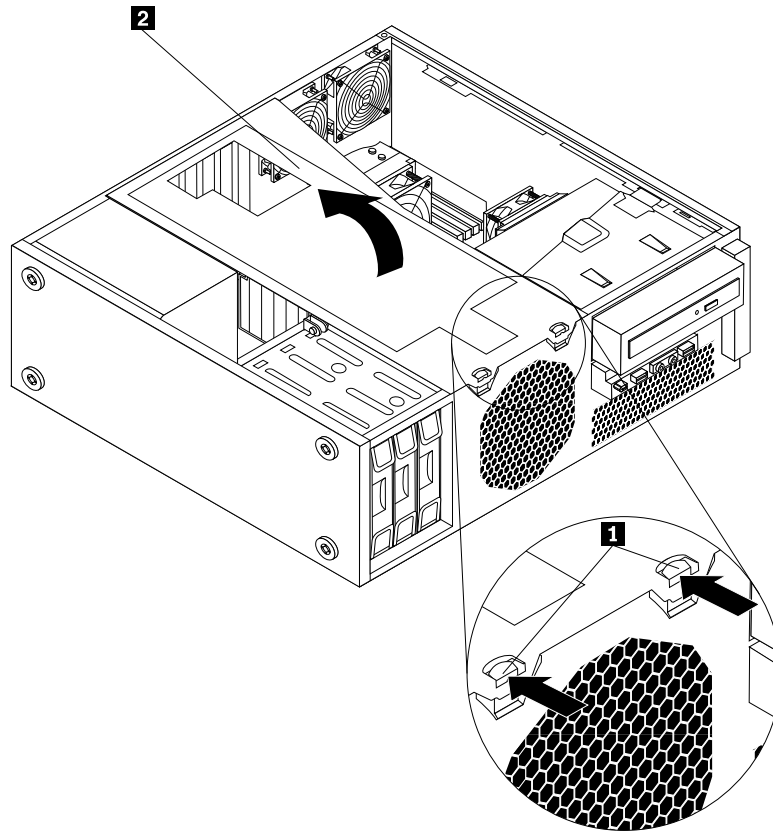

Figure 8. Removing the PCI card holder

6. To reinstall the PCI card holder into the chassis, insert the two tabs **1** into the corresponding holes in the chassis, and then pivot the PCI card holder downward until the front of the card holder snaps into position.

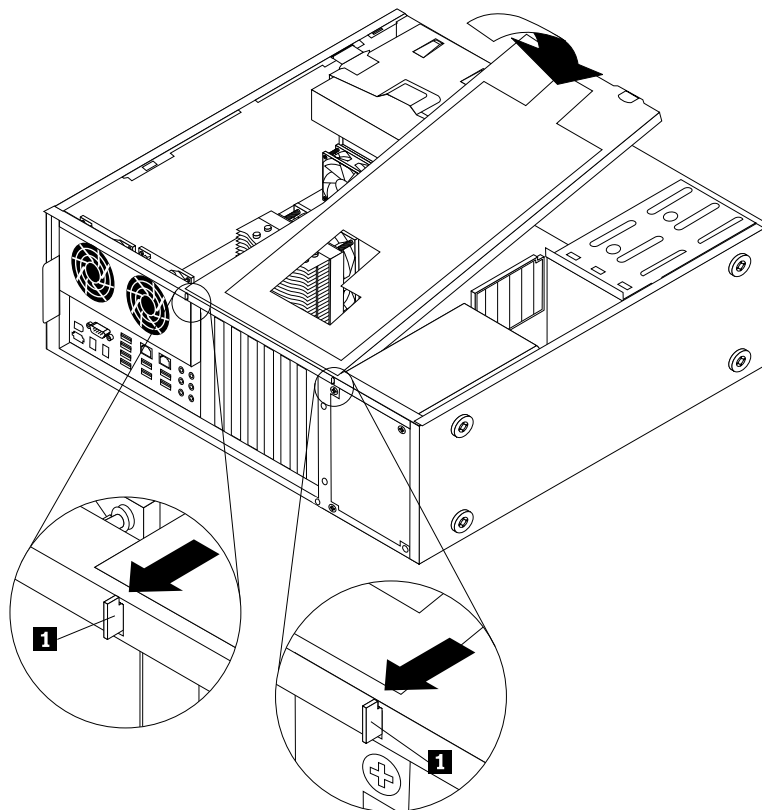

Figure 9. Installing the PCI card holder

Installing or replacing a memory module

Attention:

Do not open your computer or attempt any repair before reading and understanding the “Important safety information” in the *ThinkStation Safety and Warranty Guide* that came with your computer. To obtain a copy of the *ThinkStation Safety and Warranty Guide*, go to: <http://support.lenovo.com>

This section provides instructions on how to install or replace a memory module.

Depending on your model, your computer has six or 12 slots for installing or replacing DDR3 ECC UDIMMs (double data rate 3 error correction code unbuffered dual in-line memory modules) or DDR3 ECC RDIMMs (double data rate 3 error correction code registered dual in-line memory modules). See “Locating parts and connectors on the system board” on page 9.

When installing or replacing memory modules, use the following guidelines:

- Use either DDR3 ECC UDIMMs or DDR3 ECC RDIMMs for your computer. Do not install both the UDIMMs and RDIMMs into the same computer.
- Use 1 GB, 2 GB, or 4 GB UDIMMs in any combination up to a maximum of 24 GB or 48 GB of system memory.
- Use 1 GB, 2 GB, 4 GB, 8 GB, or 16 GB RDIMMs in any combination up to a maximum of 96 GB or 192 GB of system memory.
- Always install DIMMs in the numerical order printed on the system board (DIMM1, DIMM2, DIMM3, and so on). Install memory modules into the blue memory slots first.

- If your computer has only one CPU installed, be sure to install memory modules only in the memory slots adjacent to that CPU.
- If your computer has two CPUs installed, install equal numbers of memory modules in both sets of CPU DIMM slots for maximum performance.

To install or replace a memory module, do the following:

1. Remove all media from the drives and turn off all attached devices and the computer. Then, disconnect all power cords from electrical outlets and disconnect all cables that are connected to the computer.
2. Remove the computer cover. See “Removing the computer cover” on page 13.
3. Remove the PCI card holder. See “Removing and reinstalling the PCI card holder” on page 15.
4. Locate the memory slots. See “Locating parts and connectors on the system board” on page 9.
5. Depending on the memory module that you are replacing, do one of the following:
 - If you are replacing the memory module adjacent to CPU 1, go to step 6.
 - If you are replacing the memory module adjacent to CPU 2, do the following:
 - a. Remove the optical drive. See “Replacing the optical drive” on page 27.
 - b. Pivot the optical drive bracket as shown in the following illustration and then remove it from the chassis. Go to step 6.

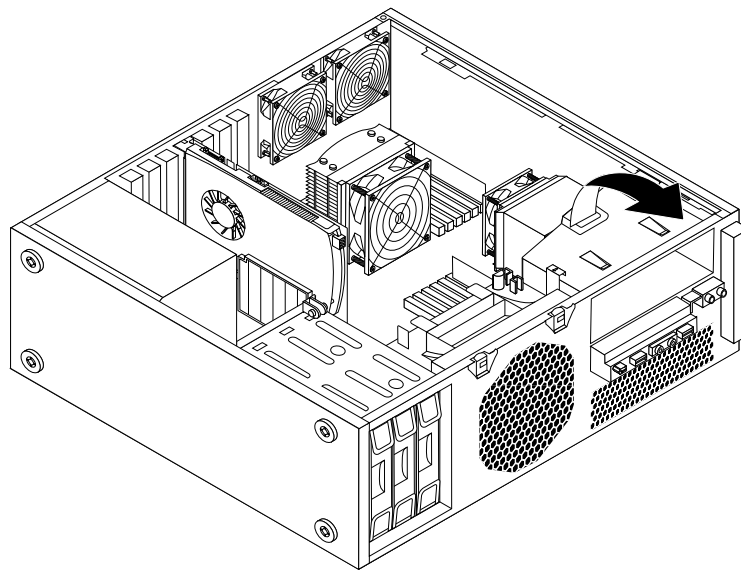

Figure 10. Removing the optical drive bracket

6. For some computer models, you might need to remove the memory fan duct to access the memory slots. To remove the memory fan duct, disconnect the memory fan cable from the system board, remove the blue shipping clip, press inward on the two tabs **1**, pivot the fan duct, and then disengage the rear of the fan duct.

Note: Not all computer models have the memory fan duct and blue shipping clip.

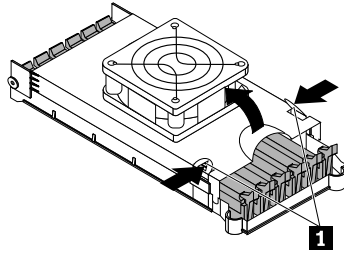

Figure 11. Removing the memory fan duct

7. Open the retaining clips as shown.

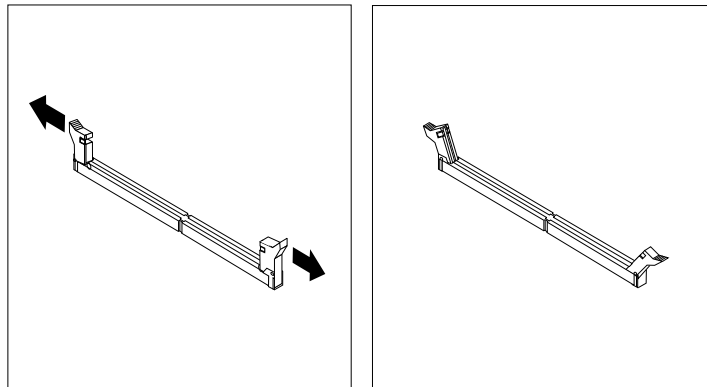

Figure 12. Opening the retaining clips

If you are replacing an old memory module, open the retaining clips and gently pull the memory module out of the memory slot.

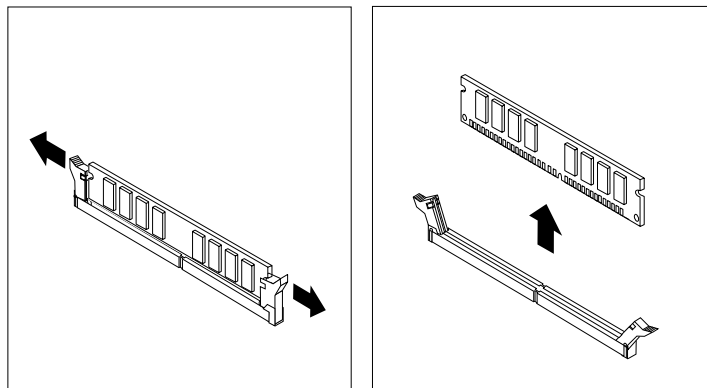
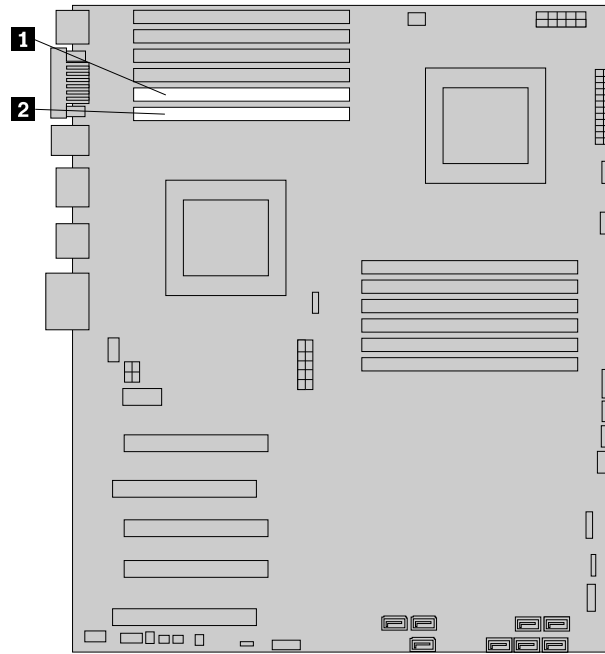

Figure 13. Removing a memory module

Notes:

- a. If your computer has 12 memory slots on the system board, you might have to use more force to remove the memory modules installed in memory slots **1** and **2**.



- b. If your computer has six memory slots on the system board, you might have to use more force to remove the memory module installed in memory slot **1**.

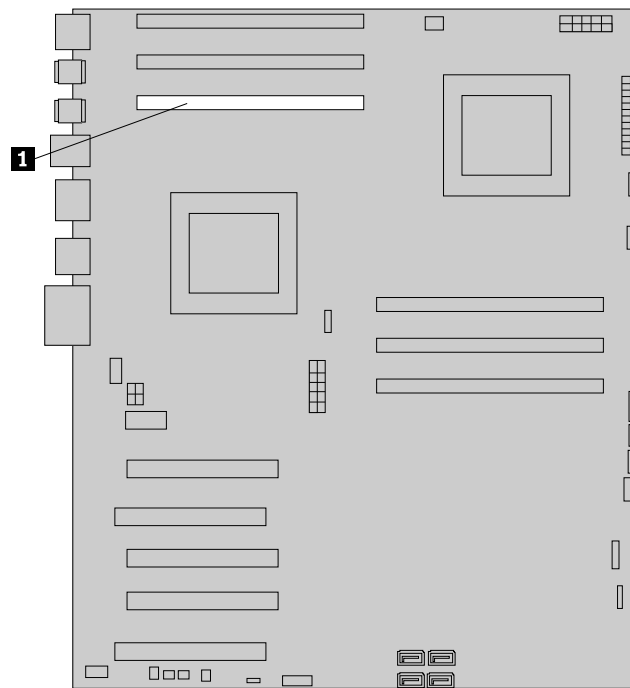

- Position the new memory module over the memory slot. Make sure that the notch **1** on the memory module aligns correctly with the key **2** in the memory slot. Push the memory module straight down into the slot until the retaining clips close.

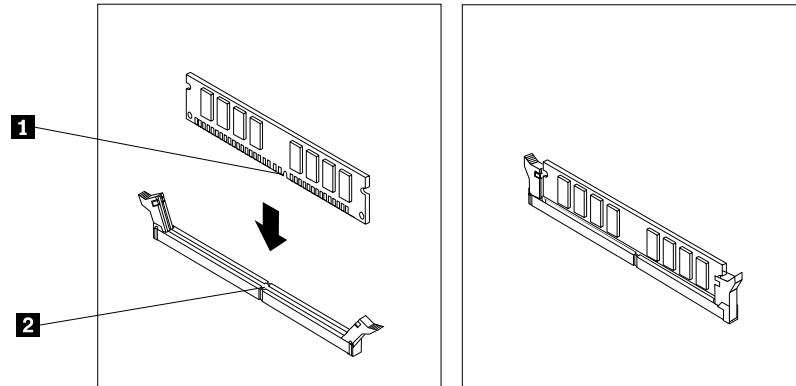

Figure 14. Installing a memory module

- To install the memory fan duct, engage the rear of the duct with the retainer on the system board and then pivot the fan duct downward until the fan duct snaps into position. Reconnect the memory fan cable to the system board. See “Locating parts and connectors on the system board” on page 9.

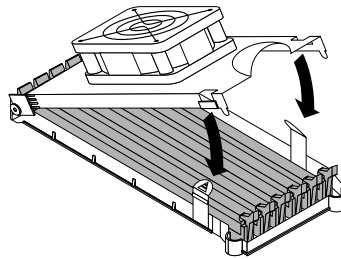

Figure 15. Installing the memory fan duct

- Reinstall the blue shipping clip if your computer needs to be repackaged and shipped in the future.
- Reinstall the optical drive bracket into the chassis if you have removed it. Then, reinstall the optical drive into the chassis. See “Replacing the optical drive” on page 27.
- Reinstall the PCI card holder. See “Removing and reinstalling the PCI card holder” on page 15.

What to do next:

- To work with another piece of hardware, go to the appropriate section.
- To complete the installation or replacement, go to “Completing the parts replacement” on page 37.

Installing or replacing a PCI card

Attention:

Do not open your computer or attempt any repair before reading and understanding the “Important safety information” in the *ThinkStation Safety and Warranty Guide* that came with your computer. To obtain a copy of the *ThinkStation Safety and Warranty Guide*, go to:
<http://support.lenovo.com>

This section provides instructions on how to install or replace a PCI card. Your computer has the following six expansion slots for installing or replacing PCI cards:

- Two PCI card slots
- One PCI Express x1 card slot
- One PCI Express x4 card slot (x16 mechanical)
- Two PCI Express x16 card slots

To install or replace a PCI card, do the following:

1. Remove all media from the drives and turn off all attached devices and the computer. Then, disconnect all power cords from electrical outlets and disconnect all cables that are connected to the computer.
2. Remove the computer cover. See “Removing the computer cover” on page 13.
3. Remove the PCI card holder. See “Removing and reinstalling the PCI card holder” on page 15.
4. If you are installing a PCI card, remove the appropriate metal slot cover. If you are replacing an old PCI card, grasp the old card that is currently installed and gently pull it out of the slot, as shown:

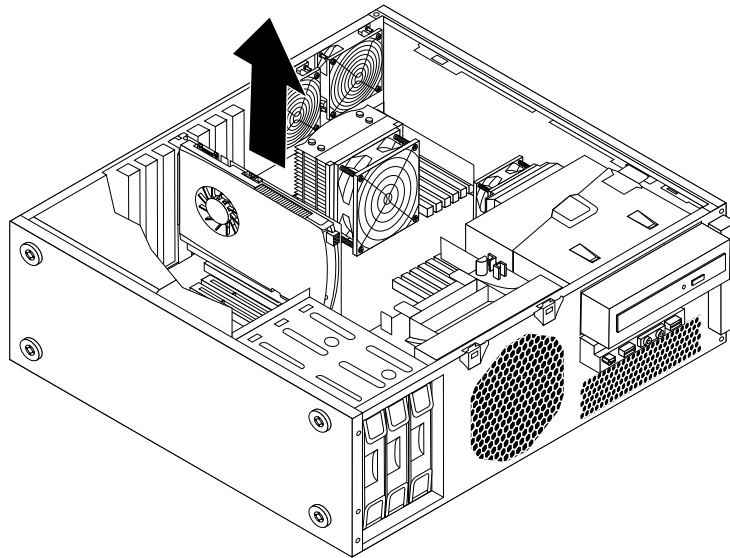
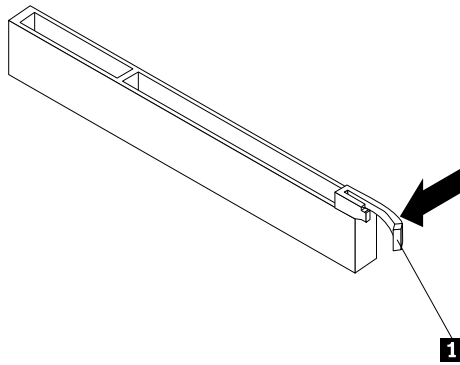

Figure 16. Removing a PCI card

Notes:

- a. The card fits tightly into the card slot. If necessary, alternate moving each side of the card a small amount until it is removed from the card slot.
- b. If the card is held in place by a retaining latch, press the card retaining latch **1** as shown to disengage the latch. Grasp the card and then gently pull it out of the slot.



5. Remove the new PCI card from its static-protective package.
6. Install the new PCI card into the appropriate slot on the system board. See “Locating parts and connectors on the system board” on page 9.

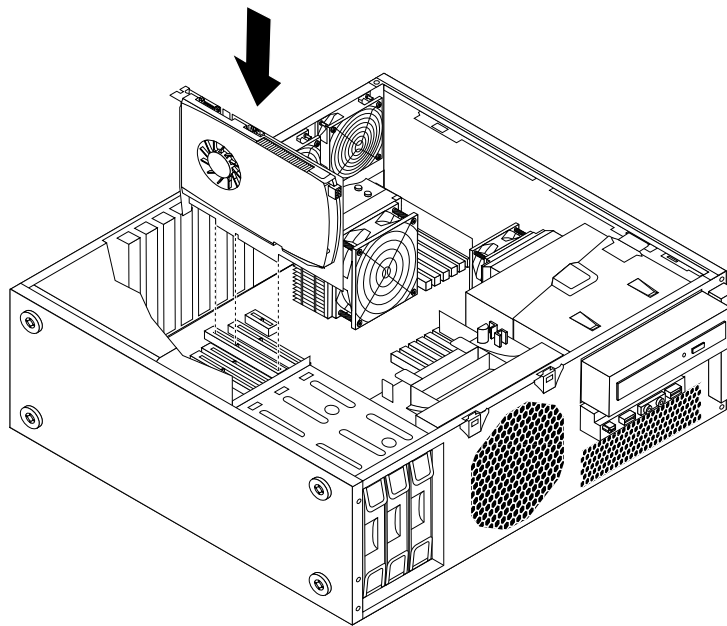

Figure 17. Installing a new PCI card

7. Reinstall the PCI card holder into the chassis. See “Removing and reinstalling the PCI card holder” on page 15.

What to do next:

- To work with another piece of hardware, go to the appropriate section.
- To complete the installation or replacement, go to “Completing the parts replacement” on page 37.

Installing a new hard disk drive

Attention:

Do not open your computer or attempt any repair before reading and understanding the “Important safety information” in the *ThinkStation Safety and Warranty Guide* that came with your computer. To obtain a copy of the *ThinkStation Safety and Warranty Guide*, go to:
<http://support.lenovo.com>

This section provides instructions on how to install a new hard disk drive into your computer.

To install a new hard disk drive, do the following:

1. Remove all media from the drives and turn off all attached devices and the computer. Then, disconnect all power cords from electrical outlets and disconnect all cables that are connected to the computer.
2. Remove the computer cover. See “Removing the computer cover” on page 13.
3. Remove the front bezel. See “Removing and reinstalling the front bezel” on page 14.
4. Remove the PCI card holder. See “Removing and reinstalling the PCI card holder” on page 15.
5. Pull the handle of a spare hard disk drive bracket out to remove the bracket from the hard disk drive bay.
6. To install a new hard disk drive into the bracket, flex the sides of the bracket properly and align pin **1**, pin **2**, pin **3**, and pin **4** on the bracket with the corresponding holes in the hard disk drive. Do not touch the circuit board **5** on the hard disk drive.

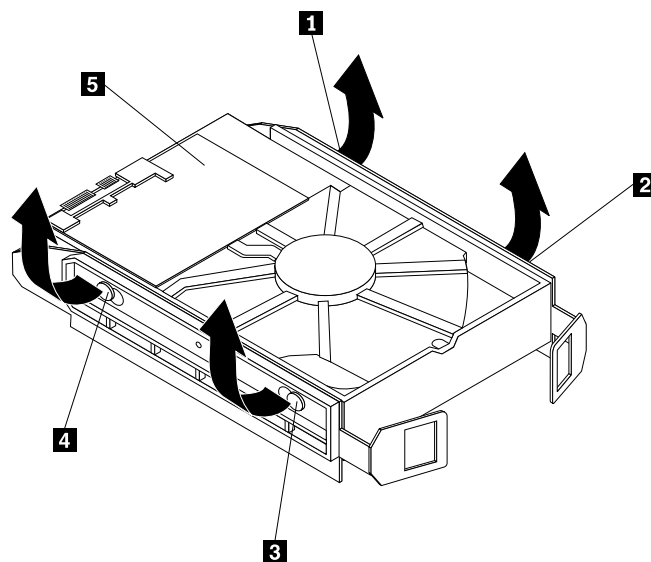

Figure 18. Installing a new hard disk drive into the bracket

7. Connect one end of the signal cable that comes with the new hard disk drive to the rear of the new hard disk drive.

Note: The signal cable will be different depending on whether you are installing a SATA hard disk drive or a SAS hard disk drive.

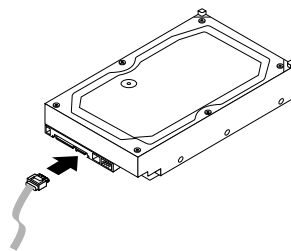

Figure 19. Connecting the signal cable to a SATA hard disk drive

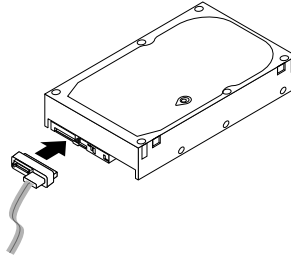

Figure 20. Connecting the signal cable to a SAS hard disk drive

8. Slide the new hard disk drive with the bracket and the signal cable into the hard disk drive bay until it snaps into position.

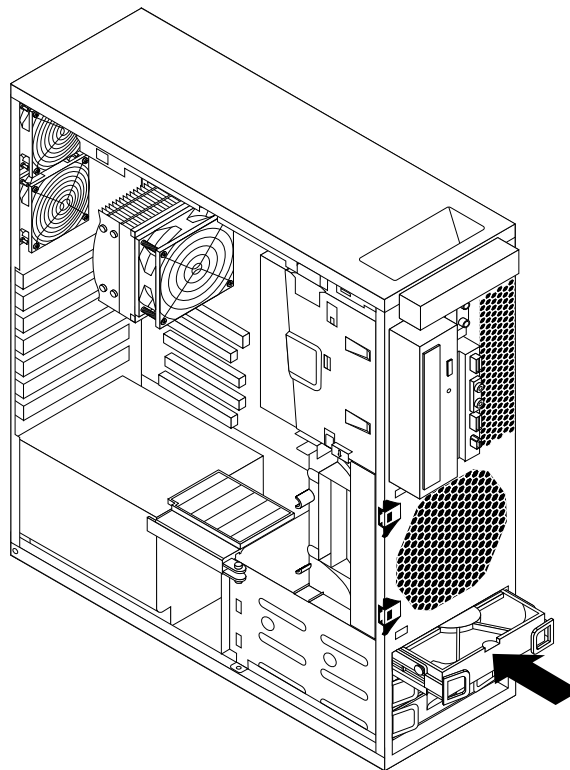

Figure 21. Installing a new hard disk drive

9. Locate one of the extra five-wire power cables and connect it to the new hard disk drive.

Note: You might need to disconnect power cables for other hard disk drives installed in your computer and then rotate the air flow wall outward for easier access to the rear of the new hard disk drive.

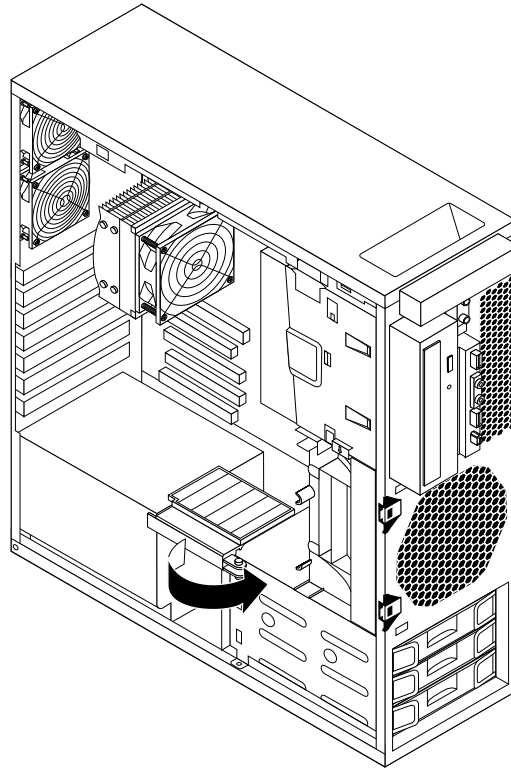

Figure 22. Rotating the air flow wall

10. Connect the other end of the signal cable to one of the available hard disk drive connectors on the system board. See “Locating parts and connectors on the system board” on page 9.
11. Reconnect all hard disk drive power cables that you have removed and then rotate the air flow wall inward into the computer.
12. Reinstall the front bezel. See “Removing and reinstalling the front bezel” on page 14.
13. Reinstall the PCI card holder. See “Removing and reinstalling the PCI card holder” on page 15.

What to do next:

- To work with another piece of hardware, go to the appropriate section.
- To complete the installation or replacement, go to “Completing the parts replacement” on page 37.

Replacing a hard disk drive

Attention:

Do not open your computer or attempt any repair before reading and understanding the “Important safety information” in the *ThinkStation Safety and Warranty Guide* that came with your computer. To obtain a copy of the *ThinkStation Safety and Warranty Guide*, go to:
<http://support.lenovo.com>

This section provides instructions on how to replace a hard disk drive.

To replace a hard disk drive, do the following:

1. Remove all media from the drives and turn off all attached devices and the computer. Then, disconnect all power cords from electrical outlets and disconnect all cables that are connected to the computer.
2. Remove the computer cover. See “Removing the computer cover” on page 13.
3. Remove the front bezel. See “Removing and reinstalling the front bezel” on page 14.
4. Locate the hard disk drive that you want to replace.
5. Disconnect the signal cable and the power cable from the rear of the hard disk drive. Press the two tabs of the hard disk drive bracket toward each other, and then pull the bracket outward to remove the hard disk drive with the bracket from the chassis.

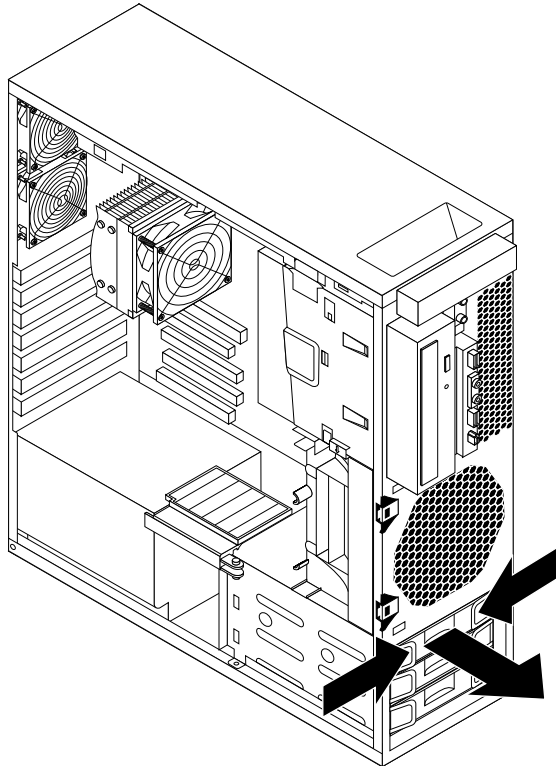

Figure 23. Removing the hard disk drive

6. Remove the failing hard disk drive from the bracket by flexing the bracket.
7. To install a new hard disk drive, go to “Installing a new hard disk drive” on page 23.

What to do next:

- To work with another piece of hardware, go to the appropriate section.
- To complete the installation or replacement, go to “Completing the parts replacement” on page 37.

Replacing the optical drive

Attention:

Do not open your computer or attempt any repair before reading and understanding the “Important safety information” in the *ThinkStation Safety and Warranty Guide* that came with your computer. To obtain a copy of the *ThinkStation Safety and Warranty Guide*, go to:
<http://support.lenovo.com>

This section provides instructions on how to replace the optical drive.

To replace the optical drive, do the following:

1. Remove all media from the drives and turn off all attached devices and the computer. Then, disconnect all power cords from electrical outlets and disconnect all cables that are connected to the computer.
2. Remove the computer cover. See “Removing the computer cover” on page 13.
3. Remove the front bezel. See “Removing and reinstalling the front bezel” on page 14.
4. Disconnect the signal cable and the power cable from the rear of the optical drive, press the blue release button **1** as shown, and then slide the optical drive out of the computer.

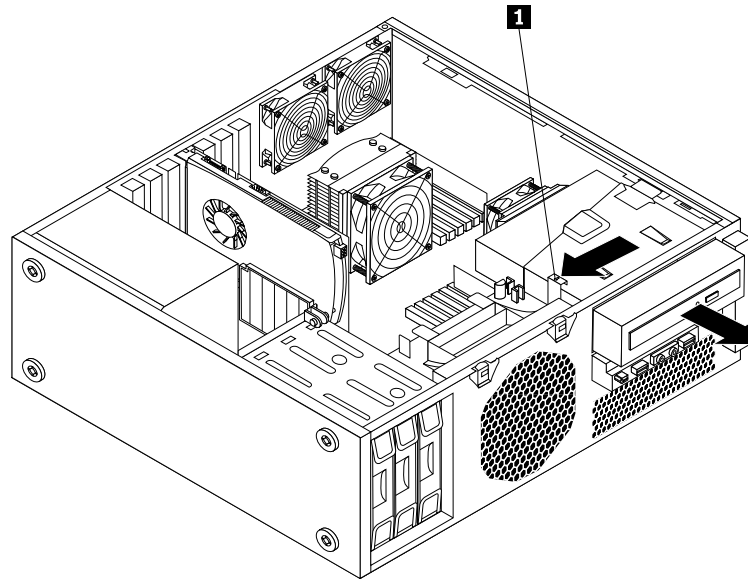

Figure 24. Removing the optical drive

5. Install the optical drive retainer **1** on the side of the new optical drive. Then, slide the new optical drive into the optical drive bracket from the front of the computer until the optical drive snaps into position.

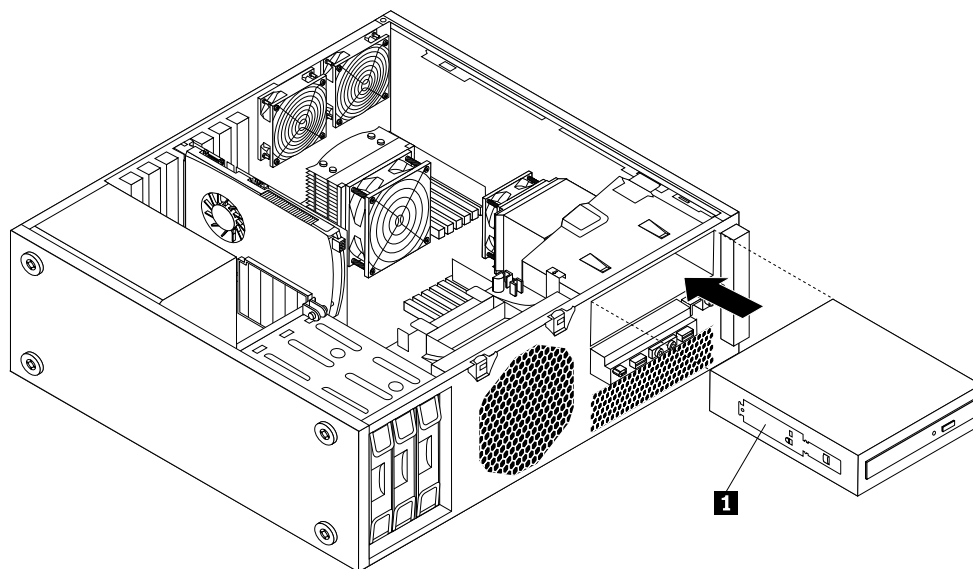

Figure 25. Installing the new optical drive

6. Connect the signal cable and the power cable to the rear of the new optical drive.
 - a. Connect the signal cable to the rear of the new optical drive.

Note: If you want to replace the signal cable, remove the PCI card holder. See “Removing and reinstalling the PCI card holder” on page 15. Then, disconnect the old signal cable from the system board. Connect one end of the new signal cable to the optical drive and the other end to an available SATA connector on the system board. See “Locating parts and connectors on the system board” on page 9.

- b. Locate an available five-wire power connector and connect it to the new optical drive.

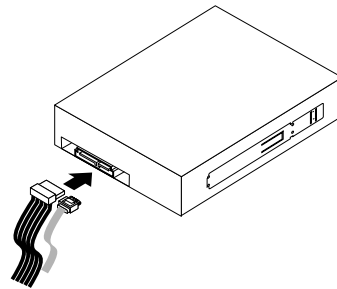

Figure 26. Connecting a new optical drive

7. Reinstall the PCI card holder into the chassis if you have removed it. See “Removing and reinstalling the PCI card holder” on page 15.
8. Reinstall the front bezel. See “Removing and reinstalling the front bezel” on page 14.

What to do next:

- To work with another piece of hardware, go to the appropriate section.
- To complete the installation or replacement, go to “Completing the parts replacement” on page 37.

Replacing the heat sink and fan assembly

Attention:

Do not open your computer or attempt any repair before reading and understanding the “Important safety information” in the *ThinkStation Safety and Warranty Guide* that came with your computer. To obtain a copy of the *ThinkStation Safety and Warranty Guide*, go to:
<http://support.lenovo.com>

CAUTION:



The heat sink and fan assembly might be very hot. Turn off the computer and wait three to five minutes to let the computer cool before removing the computer cover.

This section provides instructions on how to replace the heat sink and fan assembly.

To replace the heat sink and fan assembly, do the following:

1. Remove all media from the drives and turn off all attached devices and the computer. Then, disconnect all power cords from electrical outlets and disconnect all cables that are connected to the computer.
2. Remove the computer cover. See “Removing the computer cover” on page 13.
3. Remove the PCI card holder. See “Removing and reinstalling the PCI card holder” on page 15.
4. Your computer supports two heat sink and fan assemblies. Locate the heat sink and fan assembly you want to replace. See “Locating components” on page 8.

5. Depending on the heat sink and fan assembly you want to replace, do one of the following:
 - If you are replacing heat sink and fan assembly 1, go to step 6.
 - If you are replacing heat sink and fan assembly 2, do the following:
 - a. Remove the optical drive. See “Replacing the optical drive” on page 27.
 - b. Pivot the optical drive bracket as shown in the following illustration and then remove it from the chassis. Go to step 6.

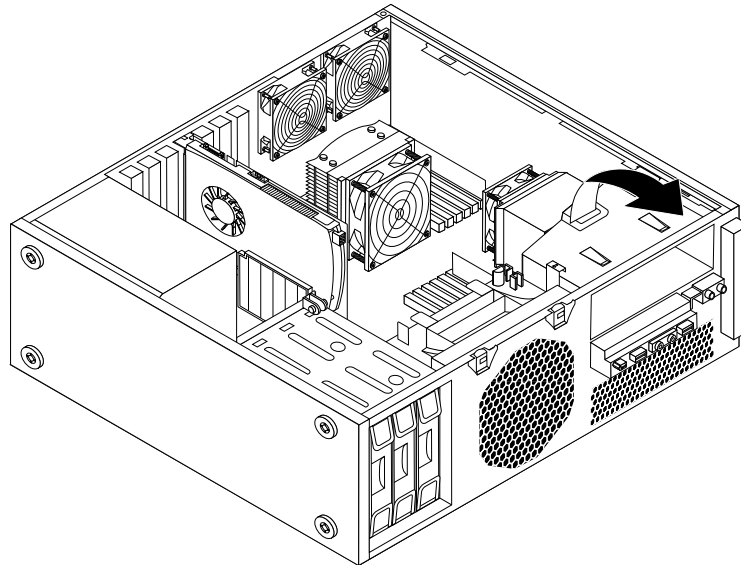

Figure 27. Removing the optical drive bracket

6. Disconnect the heat sink and fan assembly cable from the system board. Note the cable location.
7. Follow this sequence to remove the four screws that secure the heat sink and fan assembly to the system board:
 - a. Partially remove screw **1**, then fully remove screw **2**, and then fully remove screw **1**.
 - b. Partially remove screw **3**, then fully remove screw **4**, and then fully remove screw **3**.

Note: Carefully remove the four screws from the system board to avoid any possible damage to the system board. The four screws cannot be removed from the heat sink and fan assembly.

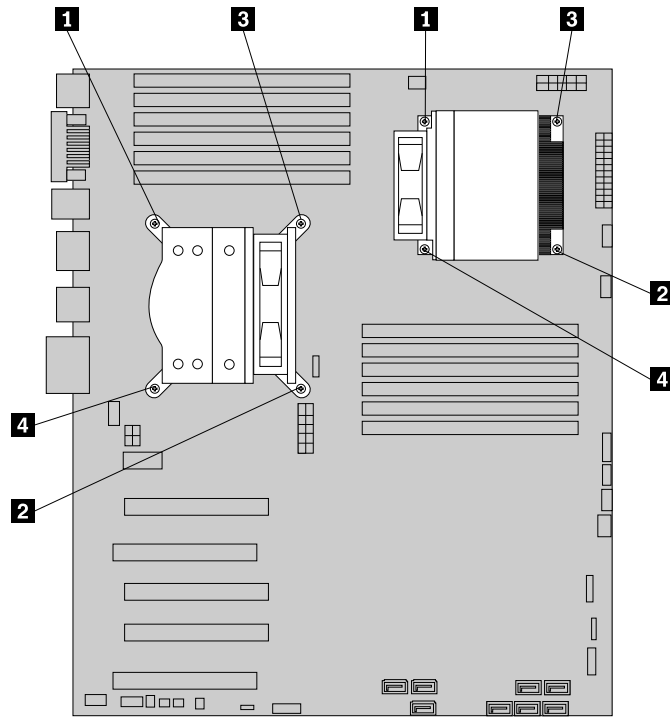

Figure 28. Removing the heat sink and fan assembly

8. Carefully lift the heat sink and fan assembly off the system board.

Notes:

- a. You might have to gently twist the heat sink and fan assembly to free it from the microprocessor.
 - b. Do not touch the thermal grease while handling the heat sink and fan assembly.
9. Remove the plastic cover from the bottom of the new heat sink and fan assembly to expose the thermal grease (this cover protects the thermal grease from contamination).

Notes:

- a. Do not remove the plastic cover until you are ready to install the heat sink and fan assembly on the microprocessor.
 - b. Do not touch the thermal grease on the heat sink and fan assembly.
 - c. Do not put the heat sink and fan assembly anywhere except on the microprocessor after the plastic cover has been removed and the thermal grease exposed.
10. Position the new heat sink and fan assembly on the microprocessor so that the four screws are aligned with the holes in the system board.

Note: Position the new heat sink and fan assembly so that the heat sink and fan assembly cable is toward the microprocessor fan connector on the system board.

11. Follow this sequence to install the four screws to secure the new heat sink and fan assembly:
 - a. Partially tighten screw **1**, then fully tighten screw **2**, and then fully tighten screw **1**.
 - b. Partially tighten screw **3**, then fully tighten screw **4**, and then fully tighten screw **3**.
12. Connect the heat sink and fan assembly cable to the system board. See “Locating parts and connectors on the system board” on page 9.
13. If you are replacing heat sink and fan assembly 2, reinstall the optical drive bracket into the chassis. Then, reinstall the optical drive into the chassis. See “Replacing the optical drive” on page 27.

14. Reinstall the PCI card holder. See “Removing and reinstalling the PCI card holder” on page 15.

What to do next:

- To work with another piece of hardware, go to the appropriate section.
- To complete the installation or replacement, go to “Completing the parts replacement” on page 37.

Replacing the front fan assembly

Attention:

Do not open your computer or attempt any repair before reading and understanding the “Important safety information” in the *ThinkStation Safety and Warranty Guide* that came with your computer. To obtain a copy of the *ThinkStation Safety and Warranty Guide*, go to:
<http://support.lenovo.com>

This section provides instructions on how to replace the front fan assembly.

Note: Not all computers have the front fan assembly.

To replace the front fan assembly, do the following:

1. Remove all media from the drives and turn off all attached devices and the computer. Then, disconnect all power cords from electrical outlets and disconnect all cables that are connected to the computer.
2. Remove the computer cover. See “Removing the computer cover” on page 13.
3. Remove the front bezel. See “Removing and reinstalling the front bezel” on page 14.
4. Remove the PCI card holder. See “Removing and reinstalling the PCI card holder” on page 15.
5. Disconnect the front fan assembly cable from the front fan connector on the system board. See “Locating parts and connectors on the system board” on page 9.

6. Press the two tabs **1** that attach the front fan assembly bracket to the chassis toward each other as shown and then completely remove the front fan assembly bracket from the chassis.

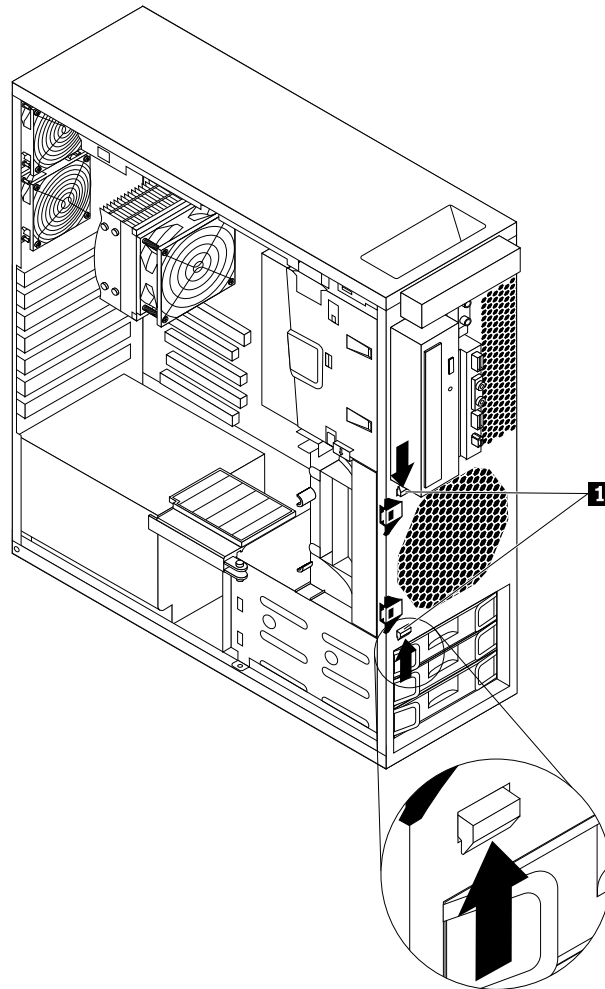

Figure 29. Removing the front fan assembly bracket

7. Insert the two tabs **1** on the new front fan assembly bracket into the corresponding holes in the chassis, and then press the two tabs through the holes until the bracket is secured in place.

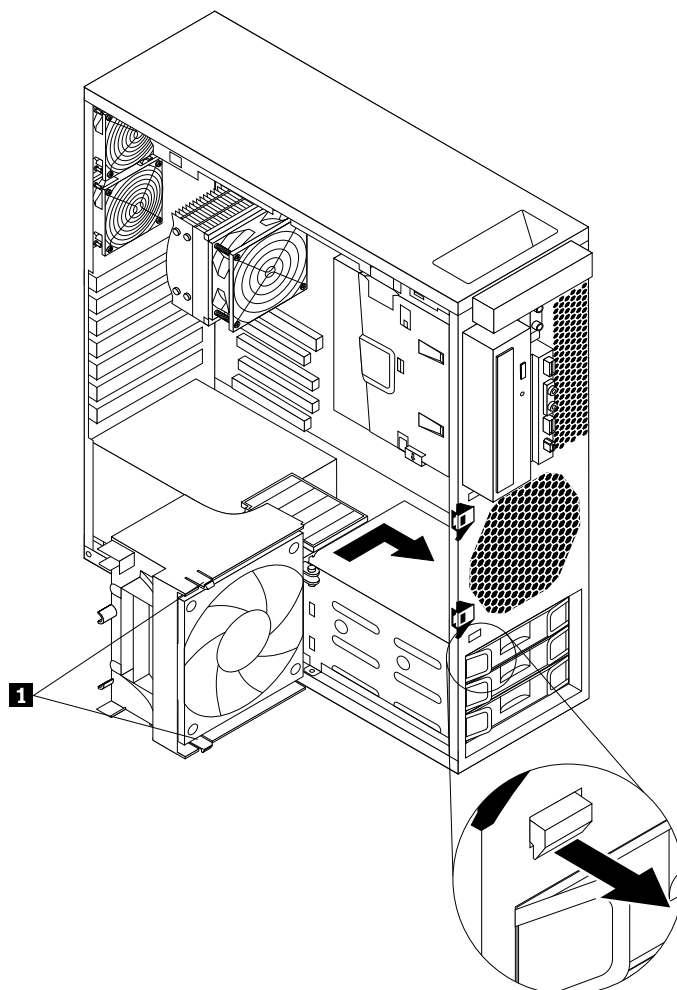

Figure 30. Installing the new front fan assembly bracket

8. Connect the front fan assembly cable to the front fan connector on the system board. See “Locating parts and connectors on the system board” on page 9.

What to do next:

- To work with another piece of hardware, go to the appropriate section.
- To complete the installation or replacement, go to “Completing the parts replacement” on page 37.

Replacing the rear fan assembly

Attention:

Do not open your computer or attempt any repair before reading and understanding the “Important safety information” in the *ThinkStation Safety and Warranty Guide* that came with your computer. To obtain a copy of the *ThinkStation Safety and Warranty Guide*, go to:
<http://support.lenovo.com>

This section provides instructions on how to replace the rear fan assembly.

Note: Your computer supports two rear fan assemblies.

To replace the rear fan assembly, do the following:

1. Remove all media from the drives and turn off all attached devices and the computer. Then, disconnect all power cords from electrical outlets and disconnect all cables that are connected to the computer.
2. Remove the computer cover. See “Removing the computer cover” on page 13.
3. Remove the front bezel. See “Removing and reinstalling the front bezel” on page 14.
4. Remove the PCI card holder for easier access to the rear fan assembly. See “Removing and reinstalling the PCI card holder” on page 15.
5. Your computer supports two rear fan assemblies. Locate the rear fan assembly you want to replace. See “Locating components” on page 8.
6. Disconnect the rear fan assembly cable from the appropriate rear fan connector on the system board. See “Locating parts and connectors on the system board” on page 9.
7. The rear fan assembly is attached to the chassis by four rubber mounts. Remove the rear fan assembly by breaking or cutting the rubber mounts and gently pulling the rear fan assembly out of the chassis.

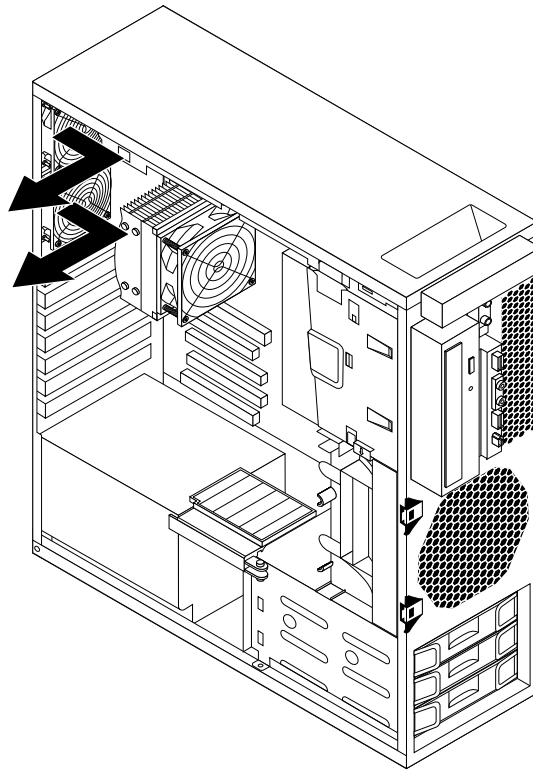

Figure 31. Removing the rear fan assembly

8. Install the new rear fan assembly by aligning the new rubber mounts with the corresponding holes in the chassis and push the rubber mounts through the holes.

Note: The new rear fan assembly you received will have four new rubber mounts attached.

9. Pull on the tips of the rubber mounts until the rear fan assembly is secured in place.

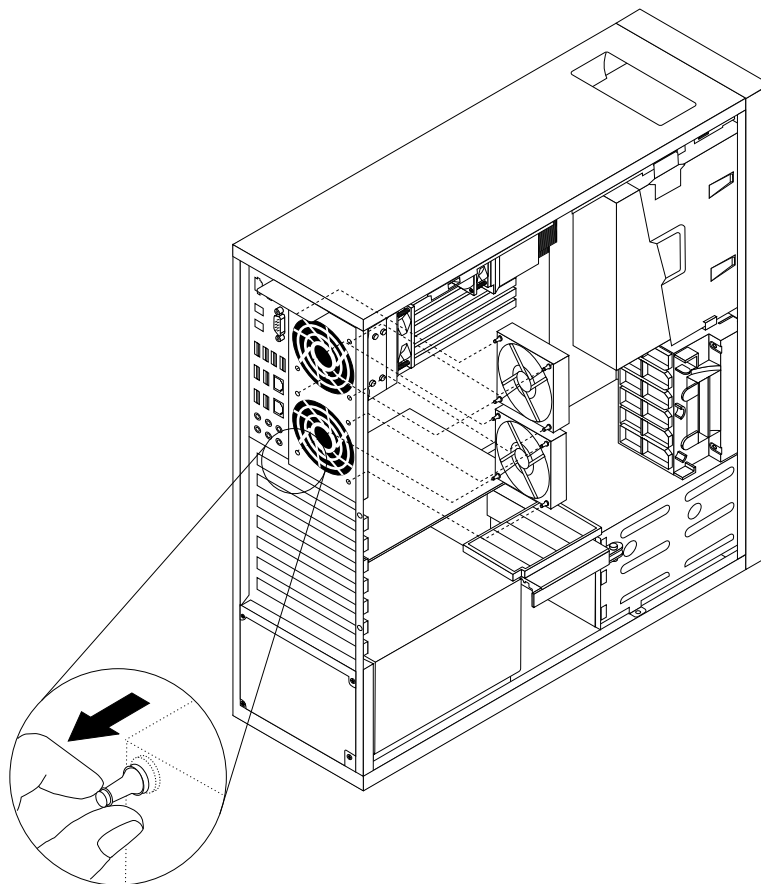

Figure 32. Installing the rear fan assembly

10. Connect the rear fan assembly cable to the appropriate rear fan connector on the system board. See “Locating parts and connectors on the system board” on page 9.

What to do next:

- To work with another piece of hardware, go to the appropriate section.
- To complete the installation or replacement, go to “Completing the parts replacement” on page 37.

Replacing the keyboard or mouse

Attention:

Do not open your computer or attempt any repair before reading and understanding the “Important safety information” in the *ThinkStation Safety and Warranty Guide* that came with your computer. To obtain a copy of the *ThinkStation Safety and Warranty Guide*, go to:
<http://support.lenovo.com>

This section provides instructions on how to replace the keyboard or mouse.

To replace the keyboard or mouse, do the following:

1. Remove any media from the drives. Then, turn off all attached devices and the computer.
2. Disconnect all power cords from electrical outlets.

3. Disconnect the old keyboard cable or mouse cable from the computer.
4. Connect a new keyboard or mouse to one of the USB connectors on the computer. Depending on where you want to connect the new keyboard or mouse, see “Locating controls and connectors on the front of your computer” on page 6 or “Locating connectors on the rear of your computer” on page 7.

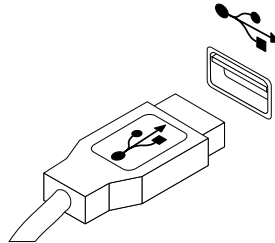

Figure 33. Connecting the USB keyboard or mouse

What to do next:

- To work with another piece of hardware, go to the appropriate section.
- To complete the installation or replacement, go to “Completing the parts replacement” on page 37.

Completing the parts replacement

After completing the installation or replacement for all parts, you need to reinstall the computer cover and reconnect cables.

To reinstall the computer cover and reconnect cables, do the following:

1. Make sure that all components have been reassembled correctly and that no tools or loose screws are left inside your computer. See “Locating components” on page 8 for the locations of various components in your computer.
2. Make sure that the cables are routed correctly before reinstalling the computer cover. Keep cables clear of the hinges and sides of the computer chassis to avoid interference with reinstalling the computer cover.
3. Reinstall the front bezel if you have removed it. See “Removing and reinstalling the front bezel” on page 14.
4. Reinstall the PCI card holder if you have removed it. See “Removing and reinstalling the PCI card holder” on page 15.

5. Position the computer cover on the chassis so that the rail guides on the bottom of the computer cover engage with the rails on the chassis. Then, close the computer cover to engage the cover-release button.

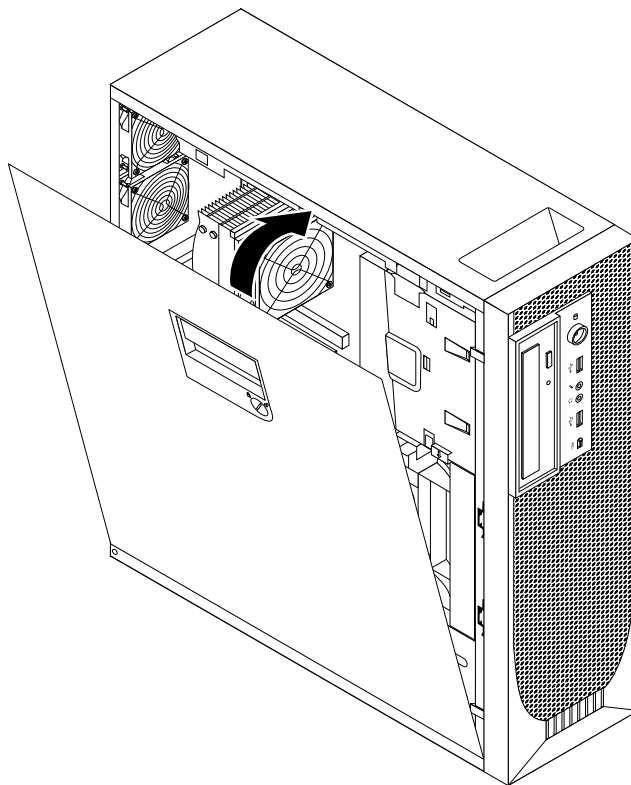

Figure 34. Reinstalling the computer cover

6. Use the keys that came with your computer to lock the keylock in the computer cover. See “Locking devices” on page 39.
7. Lock the computer if you have an integrated cable lock or a padlock. See “Locking devices” on page 39.
8. Reconnect the external cables and power cord to the computer. See “Locating connectors on the rear of your computer” on page 7.
9. Depending on the parts you installed or replaced, you might need to confirm the updated information in the Setup Utility program. Refer to Chapter 4 “Using the Setup Utility program” on page 49.

Note: In most areas of the world, Lenovo requires the return of the defective Customer Replaceable Unit (CRU). Information about this will come with the CRU or will come a few days after the CRU arrives.

Obtaining device drivers

You can obtain device drivers for operating systems that are not preinstalled at <http://support.lenovo.com>. Installation instructions are provided in readme files with the device driver files.

Basic security features

There are several security options available to help you prevent hardware theft and unauthorized access to your computer. In addition to physical locks, you can also prevent unauthorized use of your computer by a software lock that locks the keyboard until a correct password is typed in.

Locking devices

Note: Make sure that any security cables you installed do not interfere with other computer cables.

This section describes the different kinds of locking devices for your computer.

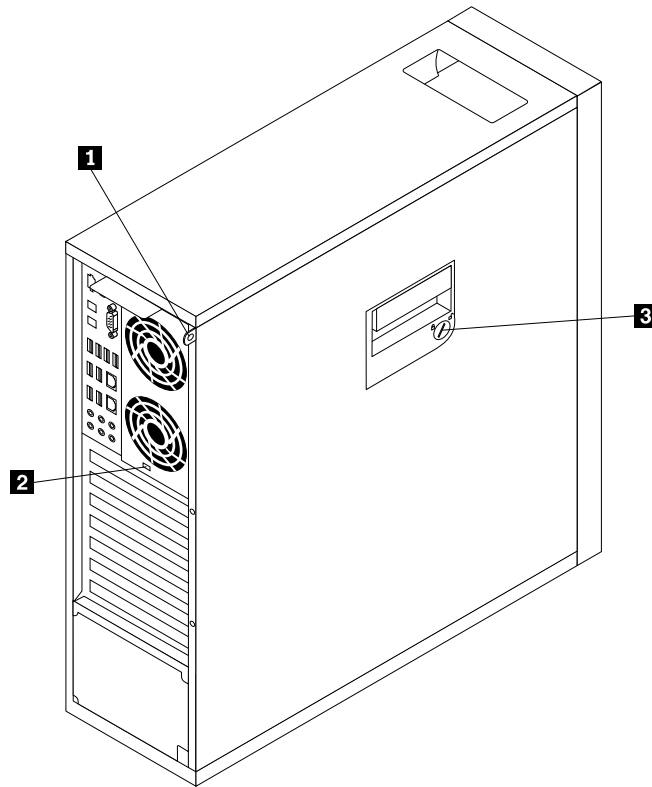

Figure 35. Locking devices

- 1** Padlock hasp
- 2** Integrated cable lock (Kensington lock)
- 3** Keylock

An optional padlock with a 5 mm (0.20 inch) shackle can be used to secure your computer using the padlock hasp **1**.

An optional integrated cable lock **2** (sometimes referred to as the Kensington lock) can be used to secure your computer to a desk, table, or other non-permanent fixture. The integrated cable lock attaches to the integrated cable lock slot in the rear of your computer and is operated with a key. This is the same type of lock used with many notebook computers. You can order an integrated cable lock from Lenovo by searching for *Kensington* at:
<http://support.lenovo.com>

Your computer comes with a keylock **3**, which was built into the computer cover. The keys for the computer cover are attached to the rear of the machine. For security, store the keys in a secure place when you are not using them.

Password protection

To deter unauthorized use of your computer, you can use the Setup Utility program to set a password. When you turn on your computer, you are prompted to type the password. The computer cannot be used until a valid password is typed in. Refer to Chapter 4 “Using the Setup Utility program” on page 49 for more information.

Chapter 3. Recovery information

This chapter provides information about the recovery solutions provided by Lenovo.

This chapter contains the following topics:

- “Creating and using recovery media” on page 41
- “Performing backup and recovery operations” on page 42
- “Using the Rescue and Recovery workspace” on page 44
- “Creating and using a rescue medium” on page 45
- “Installing or reinstalling device drivers” on page 46
- “Solving recovery problems” on page 46

Notes:

1. There are a variety of methods to choose from when considering how to recover in the event of a software- or hardware-related problem. Some methods vary depending on the type of your operating system.
2. The product on the recovery media may be used only for the following purposes:
 - Restore the product preinstalled on your computer
 - Reinstall the product
 - Modify the product using the Additional Files

Creating and using recovery media

You can use recovery media to restore the hard disk drive to the factory default settings. Recovery media are useful if you transfer the computer to another area, sell the computer, recycle the computer, or put the computer in an operational state after all other methods of recovery have failed. As a precautionary measure, it is important to create recovery media as early as possible.

Note: The recovery operations you can perform using recovery media vary depending on the operating system from which the recovery media were created. The recovery media might contain a boot medium and a data medium. Your Microsoft Windows license permits you to create only one data medium, so it is important that you store the recovery media in a safe place after you have made them.

Creating recovery media

This section provides instructions on how to create recovery media on different operating systems.

Note: On the Windows 7 operating system, you can create recovery media using discs or external USB storage devices. On the Windows XP operating system, you can create recovery media using discs only.

- To create recovery media on the Windows 7 operating system, click **Start → All Programs → Lenovo ThinkVantage Tools → Factory Recovery Disks**. Then, follow the instructions on the screen.
- To create Product Recovery discs on the Windows XP operating system, click **Start → All Programs → ThinkVantage → Create Recovery Media**. Then, follow the instructions on the screen.

Using recovery media

This section provides instructions on how to use recovery media on different operating systems.

- On the Windows 7 operating system, you can use recovery media to restore the computer to the factory default settings only. You can use recovery media to put the computer in an operational state after all other methods of recovery have failed.

Attention: When you use recovery media to restore the computer to the factory default settings, all the files currently on the hard disk drive will be deleted and replaced by the factory default settings.

To use recovery media on the Windows 7 operating system, do the following:

1. Depending on the type of your recovery media, connect the boot medium (memory key or other USB storage device) to the computer, or insert the boot disc into the optical drive.
2. Repeatedly press and release the F12 key when turning on the computer. When the **Startup Device Menu** opens, release the F12 key.
3. Select the desired startup device and press Enter. The restore process begins.
4. Follow the instructions on the screen to complete the operation.

Notes:

1. After restoring your computer to the factory default settings, you might have to reinstall device drivers for some devices. See “Installing or reinstalling device drivers” on page 46.
 2. Some computers come with Microsoft Office or Microsoft Works preinstalled. If you need to recover or reinstall your Microsoft Office or Microsoft Works applications, you must use the *Microsoft Office CD* or *Microsoft Works CD*. These discs are provided only with computers preinstalled with Microsoft Office or Microsoft Works.
- On the Windows XP operating system, you can use Product Recovery discs to restore your computer to the factory default settings, perform a custom factory recovery, or perform other rescue and recovery operations such as rescuing individual files. You will be given the option to enter the Rescue and Recovery workspace and choose from a variety of recovery operations.

Attention: When you use Product Recovery discs to restore the computer to the factory default settings, all the files currently on the hard disk drive will be deleted and replaced by the factory default settings. During the restore process, you will be given the option to save one or more files currently on the hard disk drive to other media before the data is deleted.

To use Product Recovery discs on the Windows XP operating system, do the following:

1. Repeatedly press and release the F12 key when turning on the computer. When the **Startup Device Menu** opens, release the F12 key.
2. Insert the boot disc into the optical drive.
3. Select the optical drive with the boot disc as the startup device and press Enter. After a short delay, the Rescue and Recovery workspace opens.
4. On the **Rescue and Recovery** menu, click **Restore your system**.
5. Follow the instructions on the screen. Insert the appropriate Product Recovery disc when prompted.

Performing backup and recovery operations

The Rescue and Recovery program enables you to back up all your hard disk drive contents including the operating system, data files, software programs, and personal settings. You can designate where the Rescue and Recovery program stores the backup:

- In a protected area of your hard disk drive
- On the secondary hard disk drive if a secondary hard disk drive is installed in your computer
- On an attached external USB hard disk drive
- On a network drive

- On recordable discs (a recordable optical drive is required for this option)

After you have backed up the contents on the hard disk drive, you can restore the complete contents of the hard disk drive, restore only the selected files, or restore only the Windows operating system and applications.

Performing a backup operation

This section provides instructions on how to perform a backup operation using the Rescue and Recovery program on different operating systems.

- To perform a backup operation using the Rescue and Recovery program on the Windows 7 operating system, do the following:
 1. From the Windows desktop, click **Start → All Programs → Lenovo ThinkVantage Tools → Enhanced Backup and Restore**. The Rescue and Recovery program opens.
 2. In the Rescue and Recovery main window, click the **Launch advanced Rescue and Recovery** arrow.
 3. Click **Back up your hard drive** and select backup operation options. Then, follow the instructions on the screen to complete the backup operation.
- To perform a backup operation using the Rescue and Recovery program on the Windows XP operating system, do the following:
 1. From the Windows desktop, click **Start → All Programs → ThinkVantage → Rescue and Recovery**. The Rescue and Recovery program opens.
 2. In the Rescue and Recovery main window, click **Launch advanced Rescue and Recovery → Back up your hard drive**, and select backup operation options.
 3. Follow the instructions on the screen to complete the backup operation.

Performing a recovery operation

This section provides instructions on how to perform a recovery operation using the Rescue and Recovery program on different operating systems.

- To perform a recovery operation using the Rescue and Recovery program on the Windows 7 operating system, do the following:
 1. From the Windows desktop, click **Start → All Programs → Lenovo ThinkVantage Tools → Enhanced Backup and Restore**. The Rescue and Recovery program opens.
 2. In the Rescue and Recovery main window, click the **Launch advanced Rescue and Recovery** arrow.
 3. Click the **Restore your system from a backup** icon.
 4. Follow the instructions on the screen to complete the recovery operation.
- To perform a recovery operation using the Rescue and Recovery program on the Windows XP operating system, do the following:
 1. From the Windows desktop, click **Start → All Programs → ThinkVantage → Rescue and Recovery**. The Rescue and Recovery program opens.
 2. In the Rescue and Recovery main window, click **Launch advanced Rescue and Recovery**.
 3. Click the **Restore your system from a backup** icon.
 4. Follow the instructions on the screen to complete the recovery operation.

For more information about performing a recovery operation from the Rescue and Recovery workspace, see “Using the Rescue and Recovery workspace” on page 44.

Using the Rescue and Recovery workspace

The Rescue and Recovery workspace resides in a protected, hidden area of your hard disk drive that operates independently from the Windows operating system. This enables you to perform recovery operations even if you cannot start the Windows operating system. You can perform the following recovery operations from the Rescue and Recovery workspace:

- **Rescue files from your hard disk drive or from a backup** The Rescue and Recovery workspace enables you to locate files on your hard disk drive and transfer them to a network drive or other recordable media, such as a USB device or a disc. This solution is available even if you did not back up your files or if changes were made to the files since your last backup operation. You can also rescue individual files from a Rescue and Recovery backup located on your local hard disk drive, a USB device, or a network drive.
- **Restore your hard disk drive from a Rescue and Recovery backup** If you have backed up your hard disk drive using the Rescue and Recovery program, you can restore the hard disk drive from a Rescue and Recovery backup, even if you cannot start the Windows operating system.
- **Restore your hard disk drive to the factory default settings** The Rescue and Recovery workspace enables you to restore the complete contents of your hard disk drive to the factory default settings. If you have multiple partitions on your hard disk drive, you have the option to restore the factory default settings to the C: partition and leave the other partitions intact. Because the Rescue and Recovery workspace operates independently from the Windows operating system, you can restore the factory default settings even if you cannot start the Windows operating system.

Attention: If you restore the hard disk drive from a Rescue and Recovery backup or restore the hard disk drive to the factory default settings, all files on the primary hard disk drive partition (usually drive C:) will be deleted in the recovery process. If possible, make copies of important files. If you are unable to start the Windows operating system, you can use the rescue files feature of the Rescue and Recovery workspace to copy files from your hard disk drive to other media.

To start the Rescue and Recovery workspace, do the following:

1. Make sure the computer is turned off.
2. Repeatedly press and release the F11 key when turning on the computer. When you hear beeps or see a logo screen, release the F11 key.
3. If you have set a Rescue and Recovery password, type your password when prompted. The Rescue and Recovery workspace opens after a short delay.

Note: If the Rescue and Recovery workspace fails to open, see “Solving recovery problems” on page 46.

4. Do one of the following:
 - To rescue files from your hard disk drive or from a backup, click **Rescue files** and follow the instructions on the screen.
 - To restore your hard disk drive from a Rescue and Recovery backup or to restore your hard disk drive to the factory default settings, click **Restore your system** and follow the instructions on the screen.

For more information about the features of the Rescue and Recovery workspace, click **Help**.

Notes:

1. After restoring your hard disk drive to the factory default settings, you might have to reinstall device drivers for some devices. See “Installing or reinstalling device drivers” on page 46.
2. Some computers come with Microsoft Office or Microsoft Works preinstalled. If you need to recover or reinstall your Microsoft Office or Microsoft Works applications, you must use the *Microsoft Office CD* or *Microsoft Works CD*. These discs are provided only with computers preinstalled with Microsoft Office or Microsoft Works.

Creating and using a rescue medium

With a rescue medium, such as a disc or a USB hard disk drive, you can recover the computer from failures that prevent you from gaining access to the Rescue and Recovery workspace on your hard disk drive.

Notes:

1. The recovery operations you can perform using a rescue medium vary depending on the operating system.
2. The rescue disc can be started in all types of optical drives.
3. You can also run the PC-Doctor for Rescue and Recovery diagnostic program, after using a rescue medium to recover the computer from failures and gaining access to the Rescue and Recovery workspace.

Creating a rescue medium

This section provides instructions on how to create a rescue medium on different operating systems.

- To create a rescue medium on the Windows 7 operating system, do the following:
 1. From the Windows desktop, click **Start → All Programs → Lenovo ThinkVantage Tools → Enhanced Backup and Restore**. The Rescue and Recovery program opens.
 2. In the Rescue and Recovery main window, click the **Launch advanced Rescue and Recovery** arrow.
 3. Click the **Create Rescue Media** icon. The Create Rescue and Recovery Media window opens.
 4. In the **Rescue Media** area, select the type of the rescue medium you want to create. You can create a rescue medium using a disc, a USB hard disk drive, or a secondary internal hard disk drive.
 5. Click **OK** and follow the instructions on the screen to create a rescue medium.
- To create a rescue medium on the Windows XP operating system, do the following:
 1. From the Windows desktop, click **Start → All Programs → ThinkVantage → Create Recovery Media**. The Create Rescue and Recovery Media window opens.
 2. In the **Rescue Media** area, select the type of the rescue medium you want to create. You can create a rescue medium using a disc, a USB hard disk drive, or a secondary internal hard disk drive.
 3. Click **OK** and follow the instructions on the screen to create a rescue medium.

Using a rescue medium

This section provides instructions on how to use the rescue medium you have created.

- If you have created a rescue medium using a disc, do the following to use the rescue medium:
 1. Turn off your computer.
 2. Repeatedly press and release the F12 key when turning on the computer. When the **Startup Device Menu** opens, release the F12 key.
 3. On the **Startup Device Menu**, select the desired optical drive as the first boot device. Then, insert the rescue disc into the optical drive and press Enter. The rescue medium starts.
- If you have created a rescue medium using a USB hard disk drive, do the following to use the rescue medium:
 1. Attach the USB hard disk drive to one of the USB connectors on your computer.
 2. Repeatedly press and release the F12 key when turning on the computer. When the **Startup Device Menu** opens, release the F12 key.
 3. On the **Startup Device Menu**, select the USB hard disk drive as the first boot device and press Enter. The rescue medium starts.

- If you have created a rescue medium using the secondary internal hard disk drive, set the secondary internal hard disk drive as the first boot device in the startup device sequence to start the rescue medium. See “Selecting a startup device” on page 51.

Note: The secondary internal hard disk drive is only available in some computer models.

When the rescue medium starts, the Rescue and Recovery workspace opens. The help information for each feature is available from the Rescue and Recovery workspace. Follow the instructions to complete the recovery process.

Installing or reinstalling device drivers

Before installing or reinstalling device drivers, make sure that you have a preinstalled operating system and the documentation and software media for the device.

Device drivers for factory-installed devices are located on the computer hard disk drive (usually drive C:) in the SWTOOLS\DRIVERS subdirectory. The latest device drivers for factory-installed devices are also available at <http://support.lenovo.com>. Other device drivers are on the software media that come with individual devices.

To install or reinstall the device driver for a factory-installed device, do the following:

1. Turn on the computer.
2. Go to the C:\SWTOOLS directory.
3. Open the DRIVERS folder. Within the DRIVERS folder, there are several subfolders named for various devices installed in your computer, such as AUDIO or VIDEO.
4. Open the appropriate device subfolder.
5. Do one of the following:
 - In the device subfolder, look for a SETUP.exe file. Double-click the file and follow the instructions on the screen to complete the installation.
 - In the device subfolder, look for a README.txt file or a file with the .txt extension. This file might be named after the operating system, such as WIN98.txt. The TXT file contains information about how to install the device driver. Follow the instructions to complete the installation.
 - If the device subfolder contains a file with the .inf extension and you want to install the device driver using the INF file, refer to your Windows Help and Support information system for detailed information about how to install the device driver.

Solving recovery problems

If you are unable to access the Rescue and Recovery workspace or the Windows environment, do one of the following:

- Use a rescue medium to start the Rescue and Recovery workspace. See “Creating and using a rescue medium” on page 45.
- Use recovery media if all other methods of recovery have failed and you need to restore the hard disk drive to the factory default settings. See “Creating and using recovery media” on page 41.

Note: If you are unable to access the Rescue and Recovery workspace or the Windows environment from a rescue medium or recovery media, you might not have the rescue device (an internal hard disk drive, a disc, a USB hard disk drive, or other external devices) set as the first boot device in the startup device sequence. You must first make sure that your rescue device is set as the first boot device in the startup device sequence in the Setup Utility program. See “Selecting a startup device” on page 51 for detailed

information about temporarily or permanently changing the startup device sequence. For more information about the Setup Utility program, see Chapter 4 “Using the Setup Utility program” on page 49.

It is important to create a rescue medium and a set of recovery media as early as possible and store them in a safe place for future use.

Chapter 4. Using the Setup Utility program

You can use the Setup Utility program to view and change the configuration settings of your computer, regardless of which operating system you are using. However, the operating system settings might override any similar settings in the Setup Utility program.

This chapter provides information about the following topics to help you use the Setup Utility program:

- “Starting the Setup Utility program” on page 49
- “Viewing or changing settings” on page 49
- “Using passwords” on page 49
- “Selecting a startup device” on page 51
- “Exiting the Setup Utility program” on page 52

Starting the Setup Utility program

This section provides instructions on how to start the Setup Utility program.

To start the Setup Utility program, do the following:

1. Make sure your computer is turned off.
2. Repeatedly press and release the F1 key when turning on the computer. When you hear multiple beeps or see a logo screen, release the F1 key. The Setup Utility program opens.

Note: If a password has been set, the Setup Utility program menu will not be displayed until you type the correct password. For more information, see “Using passwords” on page 49.

The Setup Utility program might start automatically when the POST detects that hardware has been removed or new hardware has been installed in your computer.

Viewing or changing settings

The Setup Utility program menu lists various items about the system configuration settings. To view or change the settings, start the Setup Utility program. See “Starting the Setup Utility program” on page 49. Then, follow the instructions on the screen.

When working with the Setup Utility program, you must use the keyboard. The keys used to perform various tasks are displayed at the bottom of each screen.

Using passwords

By using the Setup Utility program, you can set a password to prevent unauthorized access to your computer and data. The following options are available to help you set an administrator password or a user password:

- **Set Administrator Password**
- **Set User Password**

You do not have to set a password to use your computer. However, using a password improves computing security. If you decide to set a password, read the following sections.

Password considerations

A password can be any combination of up to 12 (1 to 12) alphabetic and numeric characters. For security reasons, it is recommended to use a strong password that cannot be easily compromised. To set a strong password, use the following guidelines:

Note: The Setup Utility program passwords are not case sensitive.

- Have at least eight characters in length
- Contain at least one alphabetic character and one numeric character
- Not be your name or your user name
- Not be a common word or a common name
- Be significantly different from your previous passwords

Administrator password

The **Set Administrator Password** option enables you to set an administrator password, which deters unauthorized users from changing configuration settings. If you are responsible for maintaining the settings of several computers, you might want to set an administrator password. For more information on how to set a password, see “Setting, changing, or deleting a password” on page 50.

After you have set an administrator password, a password prompt is displayed each time you try to access the Setup Utility program. You cannot access the Setup Utility program until a valid password is typed in.

If you have set both a user password and an administrator password, you can type either password to use your computer. However, to change any configuration settings, you must use your administrator password.

User Password

After you have set a user password using the **Set User Password** option, the computer cannot be used until a valid password is typed in.

Setting, changing, or deleting a password

This section provides instructions on how to set, change, or delete a password.

To set, change, or delete a password, do the following:

1. Start the Setup Utility program. See “Starting the Setup Utility program” on page 49.
2. From the Setup Utility program main menu, select **Security → Set Passwords**.
3. Depending on the password type, select **Set Administrator Password** or **Set User Password**.
4. Follow the instructions on the screen to set, change, or delete a password.

Note: A password can be any combination of up to 12 (1 to 12) alphabetic and numeric characters. For more information, see “Password considerations” on page 50.

Enabling or disabling a device

This section provides instructions on how to enable or disable user access to a device.

USB Support	Use this option to enable or disable USB connectors.
ICH SATA	When this feature is set to Disabled , any optical drives or eSATA devices are disabled and will not be displayed in the system configuration.
Marvell SATA/SAS controller	When this feature is set to Disabled , all internal hard disk drives are disabled and will not be displayed in the system configuration. When disabling this feature, make sure your system has an alternate boot method, such as LAN PXE boot, or a bootable memory key or disc.

To enable or disable a device, do the following:

1. Start the Setup Utility program. See “Starting the Setup Utility program” on page 49.
2. Depending on the device you want to enable or disable, do one of the following:
 - From the Setup Utility program main menu, select **Devices → USB Setup**. Follow the instructions on the screen to enable or disable the USB connectors.
 - From the Setup Utility program main menu, select **Devices → SAS/SATA Drive Setup**. Select **ICH SATA** or **Marvell SATA/SAS controller**. Then, select the desired settings and press Enter.
3. Press Esc to return to the Setup Utility program main menu. You might have to press Esc several times.
4. Press F10 to save the new settings and exit the Setup Utility program.

Notes:

- a. If you do not want to save the new settings, select **Exit → Exit the Setup Utility without saving**.
- b. If you want to return to the default settings, press F9 or select **Exit → Load Default Settings**.

Selecting a startup device

If your computer does not start up from a device (such as a hard disk drive or the disc in an optical drive) as expected, do one of the following to select the desired startup device.

Selecting a temporary startup device

This section provides instructions on how to select a temporary startup device. You can use the instructions in this section to start up from any startup device.

Note: Not all discs and hard disk drives are bootable.

To select a temporary startup device, do the following:

1. Turn off your computer.
2. Repeatedly press and release the F12 key when turning on the computer. When the **Startup Device Menu** opens, release the F12 key.
3. Select the desired startup device on the **Startup Device Menu** and press Enter to begin.

Note: Selecting a startup device on the **Startup Device Menu** does not permanently change the startup device sequence.

Viewing or changing the startup device sequence

This section provides instructions on how to view or permanently change the configured startup device sequence.

To view or permanently change the configured startup device sequence, do the following:

1. Start the Setup Utility program. See “Starting the Setup Utility program” on page 49.
2. Select **Startup → Startup Sequence**. Read the information displayed on the right side of the screen.

3. Select the startup devices for the Primary Startup Sequence, the Automatic Startup Sequence, and the Error Startup Sequence.
4. Press Esc to return to the Setup Utility program main menu. You might have to press Esc several times.
5. Press F10 to save the new settings and exit the Setup Utility program.

Notes:

- a. If you do not want to save the new settings, select **Exit → Exit the Setup Utility without saving**.
- b. If you want to return to the default settings, press F9 or select **Exit → Load Default Settings**.

Advanced settings

On some computer models, the **Advanced** menu includes a setting to enable or disable HyperThreading. This feature works only with HyperThreading-aware operating systems, such as the Windows 7 operating system. The default setting for HyperThreading is enabled. However, if you are not using a HyperThreading-aware operating system and you select **Enabled** for HyperThreading, your computer performance might be degraded. Therefore, you should always set HyperThreading to **Disabled** unless you are sure your operating system supports HyperThreading.

Exiting the Setup Utility program

After you finish viewing or changing settings, press Esc to return to the Setup Utility program main menu. You might have to press Esc several times. Then, you can do one of the following:

- If you want to save the new settings and exit the Setup Utility program, press F10. Otherwise, your changes will not be saved.
- If you do not want to save the new settings, select **Exit → Exit the Setup Utility without saving**.
- If you want to return to the default settings, press F9 or select **Exit → Load Default Settings**.

Chapter 5. Configuring RAID

This chapter contains information about installing hard disk drives and configuring Redundant Array of Independent Disks (RAID) for your computer.

Notes:

1. The Marvell BIOS setup information in this chapter only applies to some computer models.
2. The information about configuring RAID in this chapter only applies for a Windows environment. For information about configuring RAID in a Linux environment, contact your Linux software provider.

Configuring RAID for machine types 4262, 4263, 4264, and 4265

This section contains information about the required number of SATA hard disk drives for the supported level of RAID and SATA RAID configuration for machine types 4262, 4263, 4264, and 4265.

Installing SATA hard disk drives

Your computer must have the minimum number of SATA hard disk drives installed for the supported level of RAID below:

- RAID Level 0 – Striped disk array
 - Two hard disk drives minimum
 - Better performance without fault tolerance
- RAID Level 1 – Mirrored disk array
 - Two hard disk drives minimum
 - Improved read performance and 100% redundancy
- RAID Level 5 – Block-level striped disk array with distributed parity
 - Three hard disk drives minimum
 - Data striped at the byte level
 - Stripe error correction information
 - Better performance and fault tolerance

To install a new SATA hard disk drive, see “Installing a new hard disk drive” on page 23.

Configuring the system BIOS to enable SATA RAID functionality

This section describes how to configure the system BIOS to enable SATA RAID functionality.

Note: Use the arrow keys on the keyboard to make selections.

1. Start the Setup Utility program. See “Starting the Setup Utility program” on page 49.
2. From the Setup Utility program main menu, select **Devices → IDE Drives Setup** and press Enter.
3. Select **SATA RAID Enable** and press Enter.
4. Select **Enabled** and press Enter.
5. Press F10 to save the new settings and exit the Setup Utility program.

Creating RAID volumes

This section describes how to use the Intel Matrix Storage Manager option ROM configuration utility to create RAID volumes.

1. Press Ctrl+I when prompted to enter the Intel Matrix Storage Manager option ROM configuration utility.
2. Use the up and down arrow keys to select **Create RAID Volume** and press Enter.
3. Type a proper RAID Volume name in the **Name** field and press Tab.
4. Use the arrow keys to select a RAID level in the **RAID Level** field and press Tab.
5. If appropriate, use the arrow keys to select a Stripe Size in the **Stripe Size** field and press Tab.
6. Type a volume size in the **Capacity** field and press Tab.
7. Press Enter to initiate volume creation.
8. When prompted, press Y to accept the warning message and create the volume.
9. Return to step 2 to create additional RAID volumes, or select **Exit** and press Enter.
10. Press Y when prompted to confirm the exit.

Deleting RAID volumes

This section describes how to use the Intel Matrix Storage Manager option ROM configuration utility to delete RAID volumes.

1. Press Ctrl+I when prompted to enter the Intel Matrix Storage Manager option ROM configuration utility.
2. Use the up and down arrow keys to select **Delete RAID Volume** and press Enter.
3. Use the arrow keys to select the RAID volume to be deleted and press Delete.
4. When prompted, press Y to confirm the deletion of the selected RAID volume. Deleting a RAID volume will reset the hard disk drives to non-RAID.
5. After deleting a RAID volume, you can:
 - Return to step 2 to delete additional RAID volumes.
 - See “Creating RAID volumes” on page 54 for RAID volume creation.
 - Use the up and down arrow keys to select **Exit** and press Enter.
 - Use the up and down arrow keys to select **Reset Disks to Non-RAID** and press Enter.
 - a. Use the arrow keys and the space key to mark individual physical hard disk drives to be reset, and then press Enter to complete the selection.
 - b. When prompted, press Y to confirm the reset action.
 - c. After completing the Reset Disks to Non-RAID function, you can:
 - Return to step 2 to delete additional RAID volumes.
 - See “Creating RAID volumes” on page 54 for RAID volume creation.
 - Use the up and down arrow keys to select **Exit** and press Enter.

Configuring RAID for machine types 4266, 4269, 4271, and 4272

This section contains information about the required number of SATA or SAS hard disk drives for the supported level of RAID and SATA or SAS RAID configuration for machine types 4266, 4269, 4271, and 4272.

Note: You can install a combination of SATA and SAS hard disk drives within the same computer. However, SATA and SAS hard disk drives cannot be installed within the same RAID array.

Installing SATA or SAS hard disk drives

Your computer must have the minimum number of SATA or SAS hard disk drives installed for the supported level of RAID below:

- RAID Level 0 – Striped disk array
 - Two hard disk drives minimum
 - Better performance without fault tolerance
- RAID Level 1 – Mirrored disk array
 - Two hard disk drives minimum
 - Improved read performance and 100% redundancy
- RAID Level 5 – Block-level striped disk array with distributed parity
 - Three hard disk drives minimum
 - Data striped at the byte level
 - Stripe error correction information
 - Better performance and fault tolerance

To install a new SATA or SAS hard disk drive, see “Installing a new hard disk drive” on page 23.

Entering the Marvell BIOS Setup to configure SATA or SAS RAID

This section describes how to enter the Marvell BIOS Setup to configure a SATA or SAS RAID.

1. Turn on the computer after you have installed the required number of SATA or SAS hard disk drives.
2. Press Ctrl+M when prompted to enter the Marvell BIOS Setup to configure SATA/SAS RAID.

Configuring the Marvell BIOS Setup to enable SATA/SAS RAID 0, 1, or 5 functionality

This section provides instructions on how to enable SATA/SAS RAID functionality.

To enable SATA/SAS RAID functionality, use the Marvell BIOS Setup configuration utility as the SATA/SAS configuration utility. This utility assumes that the system has the required number of hard disk drives installed.

1. Turn on your computer and press Ctrl+M when prompted to enter the Marvell BIOS Setup.
2. On the Marvell BIOS Setup screen, use the arrow keys to select **RAID** and press Enter. The **RAID Config** menu opens.
3. From the **RAID Config** menu, select **Create array**.
4. Use the arrow keys and the Enter key to select each free hard disk drive that you want to include in the array.
5. Select **Next** and press Enter.
6. From the **Create array** menu, select **RAID level** and press Enter.

Note: Only the valid RAID levels will be active.
7. Select your desired RAID level (**RAID 0**, **RAID 1**, or **RAID 5**) and press Enter.
8. From the **Stripe Size** menu, you can change the stripe size or keep it as default.
9. Type a proper array name in the **Array Name** field.
10. Select **Next** and press Enter.
11. When prompted, press Y to complete the array creation and RAID configuration.

Configuring the Marvell BIOS Setup to set an optional hot spare hard disk drive

To configure the Marvell BIOS Setup to set an optional hot spare hard disk drive, do the following:

1. Turn on your computer and press Ctrl+M when prompted to enter the Marvell BIOS Setup.
2. On the Marvell BIOS Setup screen, use the arrow keys to select **RAID** and press Enter. The **RAID Config** menu opens.
3. From the **RAID Config** menu, select **Spare Management**.
4. Use the arrow keys to select the hard disk drive you want to set as an optional hot spare hard disk drive.
5. Use the arrow keys to select **Next** and press Enter.
6. Press Y when prompted to set the optional hot spare hard disk drive.

Configuring the Marvell BIOS Setup to delete an optional hot spare hard disk drive

To configure the Marvell BIOS Setup to delete an optional hot spare hard disk drive, do the following:

1. Turn on your computer and press Ctrl+M when prompted to enter the Marvell BIOS Setup.
2. On the Marvell BIOS Setup screen, use the arrow keys to select **RAID** and press Enter. The **RAID Config** menu opens.
3. From the **RAID Config** menu, select **Spare Management**.
4. Use the arrow keys to select the optional hot spare hard disk drive you want to delete.
5. Use the arrow keys to select **Next** and press Enter.
6. Press Y when prompted to delete the optional hot spare hard disk drive.

Configuring the Marvell BIOS Setup to delete an array

To configure the Marvell BIOS Setup to delete an array, do the following:

1. Turn on your computer and press Ctrl+M when prompted to enter the Marvell BIOS Setup.
2. On the Marvell BIOS Setup screen, use the arrow keys to select **RAID** and press Enter. The **RAID Config** menu opens.
3. From the **RAID Config** menu, select **Delete array**.
4. Use the arrow keys and the Enter key to select the array you want to delete from the list.
5. Use the arrow keys to select **Next** and press Enter.
6. Press Y when prompted to complete the deletion.

Chapter 6. Updating system programs

This chapter provides information about updating the POST and BIOS, and how to recover from a POST and BIOS update failure.

This chapter contains the following topics:

- “Using system programs” on page 57
- “Updating (flashing) the BIOS from a disc” on page 57
- “Updating (flashing) the BIOS from your operating system” on page 58

Using system programs

System programs are the basic layer of software built into your computer. System programs include the POST, the BIOS, and the Setup Utility program. The POST is a set of tests and procedures that are performed each time you turn on your computer. The BIOS is a layer of software that translates instructions from other layers of software into electrical signals that the computer hardware can execute. You can use the Setup Utility program to view or change the configuration and setup of your computer.

Your computer system board has a module called electrically erasable programmable read-only memory (EEPROM, also referred to as flash memory). You can easily update the POST, the BIOS, and the Setup Utility program by starting your computer with a system-program-update disc or running a special update program from your operating system.

Lenovo might make changes and enhancements to the POST and BIOS. When updates are released, they are available as downloadable files on the Lenovo Web site at <http://www.lenovo.com>. Instructions for using the POST and BIOS updates are available in a TXT file that is included with the update files. For most models, you can download either an update program to create a system-program-update disc or an update program that can be run from the operating system.

Updating (flashing) the BIOS from a disc

This section provides instructions on how to update (flash) the BIOS from a disc.

Note: You can download a self-starting bootable disc image (known as an ISO image) with the system program updates to create a system-program-update disc. Go to:
<http://support.lenovo.com>

To update (flash) the BIOS from a disc, do the following:

1. Turn off your computer.
2. Repeatedly press and release the F12 key when turning on the computer. When the **Startup Device Menu** opens, release the F12 key.
3. On the **Startup Device Menu**, select the desired optical drive as the first boot device. Then, insert the disc into the optical drive and press Enter. The update begins.
4. When prompted to change the serial number, it is suggested that you press N. However, if you do want to change the serial number, press Y, then type in the serial number and press Enter.
5. When prompted to change the machine type and model, it is suggested that you press N. However, if you do want to change the machine type and model, press Y, then type in the machine type and model and press Enter.

6. Follow the instructions on the screen to complete the update. After the update is completed, remove the disc from the optical drive.

Updating (flashing) the BIOS from your operating system

Note: Because Lenovo makes constant improvements to its Web sites, the Web page contents are subject to change without notice, including the contents referenced in the following procedure.

To update (flash) the BIOS from your operating system, do the following:

1. Go to <http://support.lenovo.com>.
2. Do the following to locate the downloadable files for your machine type:
 - a. In the **Enter a product number** field, type your machine type and click **Go**.
 - b. Click **Downloads and drivers**.
 - c. Select **BIOS** from the **Refine results** drop-down list box to easily locate all the BIOS related links.
 - d. Click the BIOS update link.
3. Click the TXT file that contains the instructions for updating (flashing) the BIOS from your operating system.
4. Print these instructions. This is very important because these instructions will not be displayed on the screen after the download begins.
5. Follow the printed instructions to download, extract, and install the update.

Recovering from a POST/BIOS update failure

If power to your computer is interrupted while the POST/BIOS is being updated (flash update), your computer might not restart correctly. If this happens, perform the following procedure commonly called Boot-block Recovery.

1. Turn off the computer and any attached devices, such as printers, monitors, and external drives.
2. Unplug all power cords from electrical outlets, and remove the computer cover. See “Removing the computer cover” on page 13.
3. Remove the front bezel. See “Removing and reinstalling the front bezel” on page 14.
4. Remove the PCI card holder. See “Removing and reinstalling the PCI card holder” on page 15.
5. Locate the Clear CMOS /Recovery jumper on the system board. See “Locating parts and connectors on the system board” on page 9.
6. Remove any cables that impede access to the Clear CMOS /Recovery jumper.
7. Move the jumper from the standard position (pin 1 and pin 2) to the maintenance position (pin 2 and pin 3).
8. Reinstall any parts and reconnect any cables that have been removed or disconnected.
9. Reinstall the computer cover and reconnect the power cords for the computer and monitor to electrical outlets. Refer to “Completing the parts replacement” on page 37.
10. Turn on the computer and the monitor. Insert the POST/BIOS update (flash) disc into the optical drive. The recovery session begins. The recovery session will take two to three minutes. During this time, you will hear a series of beeps.
11. After the recovery session is completed, the series of beeps will end, and the system will automatically turn off.
12. Repeat step 2 through step 6.
13. Move the Clear CMOS /Recovery jumper back to the standard position (pin 1 and pin 2).
14. Reinstall any parts and reconnect any cables that have been removed or disconnected.
15. Reinstall the computer cover and reconnect any cables that were disconnected.

16. Turn on the computer and remove the disc from the optical drive.

Chapter 7. Troubleshooting and diagnostic programs

This chapter provides information about some basic troubleshooting and diagnostic programs. If your computer problem is not described in this chapter, see Chapter 8 “Getting information, help, and service” on page 65 for additional troubleshooting resources.

This chapter contains the following topics:

- “Basic troubleshooting” on page 61
- “Diagnostic programs” on page 62
- “Cleaning an optical mouse” on page 64

Basic troubleshooting

The following table provides some basic information to help you troubleshoot your computer problems.

Note: If you cannot solve the problem after doing the basic troubleshooting, have the computer serviced. Refer to the *ThinkStation Safety and Warranty Guide* that came with your computer for the safety and warranty information and the list of Lenovo Support telephone numbers.

Symptom	Action
The computer does not start when you press the power switch.	Verify that: <ul style="list-style-type: none">• The power cord is correctly connected to the rear of the computer and to a working electrical outlet.• The power indicator on the front of the computer is on.• The computer voltage matches the voltage available at the electrical outlet for your country or region.
The monitor screen is blank.	Verify that: <ul style="list-style-type: none">• The power cord is correctly connected to the rear of the computer and to a working electrical outlet.• The computer voltage matches the voltage available at the electrical outlet for your country or region.• The brightness and contrast controls are set correctly.
The USB keyboard or mouse does not work.	Verify that: <ul style="list-style-type: none">• The computer is turned on.• The keyboard or mouse is correctly connected to one of the USB connectors on the computer.• For the keyboard, no keys are stuck.• The mouse is clean. Refer to “Cleaning an optical mouse” on page 64.
The operating system does not start.	Verify that you list the device where the operating system resides in the startup device sequence. Usually, the operating system is on the hard disk drive. For more information, see “Selecting a startup device” on page 51.
The computer beeps multiple times before the operating system starts.	Verify that no keys are stuck.

Diagnostic programs

Diagnostic programs are used to test hardware components of your computer. Diagnostic programs can also report operating-system-controlled settings that interfere with the correct operation of your system.

Depending on the preinstalled operating system and the date when your computer was manufactured, Lenovo provides one of the following diagnostic solutions:

- Lenovo Solution Center (used when the Windows operating system is running normally)
- Lenovo ThinkVantage Toolbox (used when the Windows operating system is running normally)
- PC-Doctor for Rescue and Recovery (used when you cannot start the Windows operating system)

Notes:

1. You can also download the PC-Doctor for DOS diagnostic program from <http://support.lenovo.com>. See “PC-Doctor for DOS” on page 63 for detailed information.
2. If you are unable to isolate and repair the problem yourself after running the programs, save and print the log files created by the programs. You will need the log files when you speak to a Lenovo technical support representative.

Lenovo Solution Center

The Lenovo Solution Center program enables you to troubleshoot and resolve computer problems. It combines diagnostic tests, system information collection, security status, and support information, along with hints and tips for maximum system performance.

Notes:

- The Lenovo Solution Center program is available only on models preinstalled with the Windows 7 operating system. If your Windows 7 model is not preinstalled with the program, you can download it from <http://www.lenovo.com/diagnose>.
- If you are using the Windows Vista® or Windows XP operating system, go to <http://www.lenovo.com/diagnose> for the latest information on diagnostics for your computer.

To run the Lenovo Solution Center program on the Windows 7 operating system, click **Start → All Programs → Lenovo ThinkVantage Tools → System Health and Diagnostics**. Follow the instructions on the screen.

For additional information, refer to the Lenovo Solution Center help system.

Note: If you are unable to isolate and repair the problem yourself after running the program, save and print the log files created by the program. You will need the log files when you speak to a Lenovo technical support representative.

Lenovo ThinkVantage Toolbox

The Lenovo ThinkVantage Toolbox program helps you maintain your computer, improve computing security, diagnose computer problems, get familiar with the innovative technologies provided by Lenovo, and get more information about your computer. You can use the diagnostics feature of the Lenovo ThinkVantage Toolbox program to test devices, diagnose computer problems, create bootable diagnostic media, update system drivers, and view system information.

- To run the Lenovo ThinkVantage Toolbox program on the Windows 7 operating system, click **Start → All Programs → Lenovo ThinkVantage Tools → System Health and Diagnostics**. Follow the instructions on the screen.

- To run the Lenovo ThinkVantage Toolbox program on the Windows XP operating system, click **Start → All Programs → ThinkVantage → Lenovo ThinkVantage Toolbox**. Follow the instructions on the screen.

For additional information about running the Lenovo ThinkVantage Toolbox program, refer to the Lenovo ThinkVantage Toolbox help system.

PC-Doctor for Rescue and Recovery

The PC-Doctor for Rescue and Recovery diagnostic program is part of the Rescue and Recovery workspace on your Lenovo computer. Use the PC-Doctor for Rescue and Recovery program if you are unable to start the Windows operating system.

To run the PC-Doctor for Rescue and Recovery program from the Rescue and Recovery workspace, do the following:

1. Turn off the computer.
2. Repeatedly press and release the F11 key when turning on the computer. When you hear beeps or see a logo screen, release the F11 key. The Rescue and Recovery workspace opens after a short delay.
3. From the Rescue and Recovery workspace, select **Launch advanced Rescue and Recovery → Diagnose hardware**. The PC-Doctor for Rescue and Recovery program opens.
4. Select the desired diagnostic test. Then, follow the instructions on the screen.

For additional information about running the PC-Doctor for Rescue and Recovery program, refer to the PC-Doctor for Rescue and Recovery help system.

Note: If you encounter failures that prevent you from gaining access to the Rescue and Recovery workspace, you can run the PC-Doctor for Rescue and Recovery program after using a rescue medium to recover the computer from failures and gaining access to the Rescue and Recovery workspace. See “Creating and using a rescue medium” on page 45.

PC-Doctor for DOS

You can also download the latest version of the PC-Doctor for DOS diagnostic program from <http://support.lenovo.com>. The PC-Doctor for DOS diagnostic program runs independently of the Windows operating system. Use the PC-Doctor for DOS diagnostic program if you are unable to start the Windows operating system. You can run the PC-Doctor for DOS diagnostic program from a diagnostic disc that you created.

Creating a diagnostic disc

This section provides instructions on how to create a diagnostic disc.

To create a diagnostic disc, do the following:

1. Download a self-starting bootable disc image (known as an ISO image) of the diagnostic program from: <http://support.lenovo.com>
2. Use any CD/DVD burning software to create a diagnostic disc with the ISO image.

Running the diagnostic program from the diagnostic disc

This section provides instructions on how to run the diagnostic program from the diagnostic disc that you created.

To run the diagnostic program from the diagnostic disc that you created, do the following:

1. Make sure that your computer is turned off.
2. Repeatedly press and release the F12 key when turning on the computer. When the **Startup Device Menu** opens, release the F12 key.

3. Insert the diagnostic disc into the optical drive.
4. Select the optical drive with the diagnostic disc as the startup device and press Enter. The diagnostic program opens.
5. Follow the instructions on the screen to run the desired diagnostic test. For additional help, press the F1 key.
6. Remove the diagnostic disc from the optical drive after completing the diagnostic test.

Cleaning an optical mouse

This section provides instructions on how to clean an optical mouse.

An optical mouse uses a LED and an optical sensor to navigate the pointer. If the pointer on the screen does not move smoothly with the optical mouse, you might need to clean the mouse.

To clean an optical mouse, do the following:

1. Turn off your computer.
2. Disconnect the mouse cable from the computer.
3. Turn the mouse upside down to view the lens.
 - a. If there is a smudge on the lens, gently clean the area with a plain cotton-tipped swab.
 - b. If there is debris in the lens, gently blow the debris away from the area.
4. Check the surface on which you are using the mouse. If you have a very intricate picture or pattern beneath the mouse, it may be difficult for the digital signal processor (DSP) to determine changes in the mouse position.
5. Reconnect the mouse cable to the computer.
6. Turn your computer back on.

Chapter 8. Getting information, help, and service

This chapter provides information about help, service, and technical assistance for Lenovo products.

This chapter contains the following topics:

- “Information resources” on page 65
- “Help and service” on page 66

Information resources

You can use the information in this section to access useful resources relating to your computing needs.

Online Books folder

The Online Books folder preinstalled on your computer contains the *ThinkStation User Guide*, which provides information about your computer to help you set up, use, and maintain your computer. It requires no Internet access to view the publication.

To view the publication, click **Start → All Programs → Online Books → Online Books**, then double-click the publication for your computer. The publication is also available on the Lenovo Support Web site at: <http://support.lenovo.com>

Notes:

1. The publication is in PDF version. To view the publication, you need to have the Adobe Reader program preinstalled on your computer. If the Adobe Reader program has not been installed on your computer, a message will be displayed when you attempt to view the PDF file and you will be guided through the Adobe Reader installation.
2. The publication is available in other languages on the Lenovo Support Web site at: <http://support.lenovo.com>
3. If you want to install a different language version of the Adobe Reader program rather than the version preinstalled on your computer, download the desired language version from the Adobe Web site at: <http://www.adobe.com>

Lenovo ThinkVantage Tools

Note: The Lenovo ThinkVantage Tools program is only available on computers with the Windows 7 operating system from Lenovo.

The Lenovo ThinkVantage Tools program helps you work more easily and securely by providing easy access to various tools, such as:

- Lenovo ThinkVantage Toolbox or Lenovo Solution Center
- Product Recovery
- Rescue and Recovery

To access the Lenovo ThinkVantage Tools program, click **Start → All Programs → Lenovo ThinkVantage Tools**.

Lenovo Welcome

Note: The Lenovo Welcome program is only available on computers preinstalled with the Windows 7 operating system from Lenovo.

The Lenovo Welcome program introduces some innovative built-in features of Lenovo to you and guides you through some important setup tasks to help you make the most of your computer.

Safety and warranty

The *ThinkStation Safety and Warranty Guide* that came with your computer contains information about safety, warranty, service and support phone numbers, CRUs, and other notices and information resources.

Before using the information in this manual and the product it supports, be sure to read and understand the *ThinkStation Safety and Warranty Guide* and Appendix B “Notices” on page 73.

Lenovo Web site

The Lenovo Web site provides up-to-date information and services to help you buy, upgrade, and maintain your computer. You can also do the following:

- Shop for desktop and notebook computers, monitors, projectors, upgrades and accessories for your computer, and special offers.
- Purchase additional services, such as support for hardware, operating systems, application programs, network setup and configuration, and custom installations.
- Purchase upgrades and extended hardware repair services.
- Download the latest device drivers and software updates for your computer model.
- Access the online manuals for your products.
- Access the Lenovo Limited Warranty.
- Access troubleshooting and support information for your computer model and other supported products.
- Find the service and support phone numbers for your country or region.
- Find a Service Provider located near you.

Lenovo Support Web site

Technical support information is available on the Lenovo Support Web site at:
<http://www.lenovo.com/support>

This Web site is updated with the latest support information such as the following:

- Drivers and software
- Diagnostic solutions
- Product and service warranty
- Product and parts details
- User guides and manuals
- Knowledge base and frequently asked questions

Help and service

This section contains information about obtaining help and service.

Using the documentation and diagnostic programs

If you experience a problem with your computer, see Chapter 7 “Troubleshooting and diagnostic programs” on page 61. For information on additional resources to help you troubleshoot your computer problem, see “Information resources” on page 65.

If you suspect a software problem, see the documentation that comes with the operating system or software program, including readme files and online help.

Most computers come with a set of diagnostic programs that you can use to help you identify hardware problems. For instructions on using the diagnostic programs, see “Diagnostic programs” on page 62.

You can get the latest technical information and download device drivers and updates from the Lenovo Support Web site at:
<http://support.lenovo.com>

Calling for service

During the warranty period, you can get help and information by telephone through the Customer Support Center.

The following services are available during the warranty period:

- **Problem determination** - Trained service personnel are available to assist you with determining a hardware problem and deciding what action is necessary to fix the problem.
- **Hardware repair** - If the problem is caused by hardware under warranty, trained service personnel are available to provide the applicable level of service.
- **Engineering Change management** - There might be changes that are required after a product has been sold. Lenovo or your reseller will make selected Engineering Changes (ECs) that apply to your hardware available.

The following items are not covered by the warranty:

- Replacement or use of parts not manufactured for or by Lenovo or non-warranted Lenovo parts
- Identification of software problem sources
- Configuration of BIOS as part of an installation or upgrade
- Changes, modifications, or upgrades to device drivers
- Installation and maintenance of network operating systems (NOS)
- Installation and maintenance of application programs

Refer to the safety and warranty information that is provided with your computer for a complete explanation of warranty terms. You must retain your proof of purchase to obtain warranty service.

For a list of the Lenovo Support phone numbers for your country or region, go to <http://www.lenovo.com/support/phone> and click **Support phone list** or refer to the *ThinkStation Safety and Warranty Guide* that is provided with your computer.

Note: Phone numbers are subject to change without notice. If the number for your country or region is not provided, contact your Lenovo reseller or Lenovo marketing representative.

If possible, be at your computer when you call. Have the following information available:

- Machine type and model
- Serial numbers of your hardware products
- Description of the problem
- Exact wording of any error messages
- Hardware and software configuration information

Using other services

If you travel with your computer or relocate it to a country where your desktop or notebook computer machine type is sold, your computer might be eligible for International Warranty Service, which automatically

entitles you to obtain warranty service throughout the warranty period. Service will be performed by service providers authorized to perform warranty service.

Service methods and procedures vary by country, and some services might not be available in all countries. International Warranty Service is delivered through the method of service (such as depot, carry-in, or on-site service) that is provided in the servicing country. Service centers in certain countries might not be able to service all models of a particular machine type. In some countries, fees and restrictions might apply at the time of service.

To determine whether your computer is eligible for International Warranty Service and to view a list of the countries where service is available, go to <http://support.lenovo.com>, click **Warranty**, and follow the instructions on the screen.

For technical assistance with the installation of or questions related to Service Packs for your preinstalled Microsoft Windows product, refer to the Microsoft Product Support Services Web site at <http://support.microsoft.com/directory> or you can contact the Customer Support Center. Some fees might apply.

Purchasing additional services

During and after the warranty period, you can purchase additional services, such as support for hardware, operating systems, and application programs; network setup and configuration; upgraded or extended hardware repair services; and custom installations. Service availability and service name might vary by country or region. For more information about these services, go to the Lenovo Web site at: <http://www.lenovo.com>

Appendix A. System memory speed

The Intel Xeon microprocessor families compatible with this ThinkStation computer feature an integrated memory controller, which provides the microprocessor with direct access to the system memory. Because of this design, the system memory speed will be determined by a number of factors, including the microprocessor model and the type, speed, size (capacity), and number of DIMMs installed. Refer to the following table for the information on the supported system memory speed for your computer model.

Table 1. DIMM type and speed: PC3-10600U

DIMM size (capacity)	Number of DIMMs installed per microprocessor bank	Microprocessor model	Memory frequency
1 GB, 2 GB, 4 GB	1 to 3	Intel Xeon E5502, E5503, E5504, E5506, E5507	800 MHz
		Intel Xeon E5603, E5606, E5607, E5520, E5530, E5540, E5620, E5630, E5640	1066 MHz
		Intel Xeon E5645, E5649, X5550, X5560, X5570, X5650, X5660, X5667, X5670, X5672, X5675	1333 MHz

Table 2. DIMM type and speed: PC3-8500U

DIMM size (capacity)	Number of DIMMs installed per microprocessor bank	Microprocessor model	Memory frequency
1 GB, 2 GB, 4 GB	1 to 3	Intel Xeon E5502, E5503, E5504, E5506, E5507	800 MHz
		Intel Xeon E5603, E5606, E5607, E5520, E5530, E5540, E5620, E5630, E5640, E5645, E5649, X5550, X5560, X5570, X5650, X5660, X5667, X5670, X5672, X5675	1066 MHz

Table 3. DIMM type and speed: PC3-10600R

DIMM size (capacity)	Number of DIMMs installed per microprocessor bank	Microprocessor model	Memory frequency
1 GB, 2 GB, 4 GB, 8 GB	1 to 3	Intel Xeon E5502, E5503, E5504, E5506, E5507	800 MHz
		Intel Xeon E5603, E5606, E5607, E5520, E5530, E5540, E5620, E5630, E5640	1066 MHz
		Intel Xeon E5645, E5649, X5550, X5560, X5570,	1333 MHz

Table 3. DIMM type and speed: PC3-10600R (continued)

DIMM size (capacity)	Number of DIMMs installed per microprocessor bank	Microprocessor model	Memory frequency
		X5650, X5660, X5667, X5670, X5672, X5675	

Table 4. DIMM type and speed: PC3-8500R

DIMM size (capacity)	Number of DIMMs installed per microprocessor bank	Microprocessor model	Memory frequency
1 GB, 2 GB, 4 GB, 8 GB, 16 GB	1 to 3	Intel Xeon E5502, E5503, E5504, E5506, E5507	800 MHz
		Intel Xeon E5603, E5606, E5607, E5520, E5530, E5540, E5620, E5630, E5640, E5645, E5649, X5550, X5560, X5570, X5650, X5660, X5667, X5670, X5672, X5675	1066 MHz

Table 5. DIMM type and speed: PC3-10600U

DIMM size (capacity)	Number of DIMMs installed per microprocessor bank	Microprocessor model	Memory frequency
1 GB, 2 GB, 4 GB	1 to 3	Intel Xeon E5502, E5503, E5504, E5506, E5507	800 MHz
		Intel Xeon E5603, E5606, E5607, E5520, E5530, E5540, E5620, E5630, E5640, X5647	1066 MHz
		Intel Xeon E5645, E5649, X5550, X5560, X5570, X5650, X5660, X5667, X5670, X5672, X5675, X5677, X5680, X5687, X5690, W5580, W5590	1333 MHz
	4 to 6	Intel Xeon E5502, E5503, E5504, E5506, E5507	800 MHz
		Intel Xeon E5603, E5606, E5607, E5520, E5530, E5540, E5620, E5630, E5640, X5550, X5560, X5570, X5647, W5580, W5590	1066 MHz
		Intel Xeon E5645, E5649, X5650, X5660, X5667, X5670, X5672, X5675, X5677, X5680, X5687, X5690	1333 MHz

Table 6. DIMM type and speed: PC3-8500U

DIMM size (capacity)	Number of DIMMs installed per microprocessor bank	Microprocessor model	Memory frequency
1 GB, 2 GB, 4 GB	1 to 6	Intel Xeon E5502, E5503, E5504, E5506, E5507	800 MHz
		Intel Xeon E5603, E5606, E5607, E5520, E5530, E5540, E5620, E5630, E5640, E5645, X5647, E5649, X5550, X5560, X5570, X5650, X5660, X5667, X5670, X5672, X5675, X5677, X5680, X5687, X5690, W5580, W5590	1066 MHz

Table 7. DIMM type and speed: PC3-10600R

DIMM size (capacity)	Number of DIMMs installed per microprocessor bank	Microprocessor model	Memory frequency
1 GB, 2 GB, 4 GB, 8 GB	1 to 3	Intel Xeon E5502, E5503, E5504, E5506, E5507	800 MHz
		Intel Xeon E5603, E5606, E5607, E5520, E5530, E5540, E5620, E5630, E5640, X5647	1066 MHz
		Intel Xeon E5645, E5649, X5550, X5560, X5570, X5650, X5660, X5667, X5670, X5672, X5675, X5677, X5680, X5687, X5690, W5580, W5590	1333 MHz
	4 to 6	Intel Xeon E5502, E5503, E5504, E5506, E5507	800 MHz
		Intel Xeon E5603, E5606, E5607, E5520, E5530, E5540, E5620, E5630, E5640, X5550, X5560, X5570, X5647, W5580, W5590	1066 MHz
		Intel Xeon E5645, E5649, X5650, X5660, X5667, X5670, X5672, X5675, X5677, X5680, X5687, X5690	1333 MHz

Table 8. DIMM type and speed: PC3-8500R

DIMM size (capacity)	Number of DIMMs installed per microprocessor bank	Microprocessor model	Memory frequency
1 GB, 2 GB, 4 GB	1 to 6	Intel Xeon E5502, E5503, E5504, E5506, E5507	800 MHz
		Intel Xeon E5603, E5606, E5607, E5520, E5530, E5540, E5620, E5630, E5640, E5645, E5649, X5647, X5550, X5560, X5570, X5650, X5660, X5667, X5670, X5672, X5675, X5677, X5680, X5687, X5690, W5580, W5590	1066 MHz
8 GB, 16 GB	1 to 3	Intel Xeon E5502, E5503, E5504, E5506, E5507	800 MHz
		Intel Xeon E5603, E5606, E5607, E5520, E5530, E5540, E5620, E5630, E5640, E5645, E5649, X5647, X5550, X5560, X5570, X5650, X5660, X5667, X5670, X5672, X5675, X5677, X5680, X5687, X5690, W5580, W5590	1066 MHz
	4 to 6	Intel Xeon E5502, E5503, E5504, E5506, E5507, E5603, E5606, E5607, E5520, E5530, E5540, E5620, E5630, E5640, E5645, E5649, X5647, X5550, X5560, X5570, X5650, X5660, X5667, X5670, X5672, X5675, X5677, X5680, X5687, X5690, W5580, W5590	800 MHz

Appendix B. Notices

Lenovo may not offer the products, services, or features discussed in this document in all countries. Consult your local Lenovo representative for information on the products and services currently available in your area. Any reference to a Lenovo product, program, or service is not intended to state or imply that only that Lenovo product, program, or service may be used. Any functionally equivalent product, program, or service that does not infringe any Lenovo intellectual property right may be used instead. However, it is the user's responsibility to evaluate and verify the operation of any other product, program, or service.

Lenovo may have patents or pending patent applications covering subject matter described in this document. The furnishing of this document does not give you any license to these patents. You can send license inquiries, in writing, to:

*Lenovo (United States), Inc.
1009 Think Place - Building One
Morrisville, NC 27560
U.S.A.
Attention: Lenovo Director of Licensing*

LENOVO PROVIDES THIS PUBLICATION "AS IS" WITHOUT WARRANTY OF ANY KIND, EITHER EXPRESS OR IMPLIED, INCLUDING, BUT NOT LIMITED TO, THE IMPLIED WARRANTIES OF NON-INFRINGEMENT, MERCHANTABILITY OR FITNESS FOR A PARTICULAR PURPOSE. Some jurisdictions do not allow disclaimer of express or implied warranties in certain transactions, therefore, this statement may not apply to you.

This information could include technical inaccuracies or typographical errors. Changes are periodically made to the information herein; these changes will be incorporated in new editions of the publication. Lenovo may make improvements and/or changes in the product(s) and/or the program(s) described in this publication at any time without notice.

The products described in this document are not intended for use in implantation or other life support applications where malfunction may result in injury or death to persons. The information contained in this document does not affect or change Lenovo product specifications or warranties. Nothing in this document shall operate as an express or implied license or indemnity under the intellectual property rights of Lenovo or third parties. All information contained in this document was obtained in specific environments and is presented as an illustration. The result obtained in other operating environments may vary.

Lenovo may use or distribute any of the information you supply in any way it believes appropriate without incurring any obligation to you.

Any references in this publication to non-Lenovo Web sites are provided for convenience only and do not in any manner serve as an endorsement of those Web sites. The materials at those Web sites are not part of the materials for this Lenovo product, and use of those Web sites is at your own risk.

Any performance data contained herein was determined in a controlled environment. Therefore, the result obtained in other operating environments may vary significantly. Some measurements may have been made on development-level systems and there is no guarantee that these measurements will be the same on generally available systems. Furthermore, some measurements may have been estimated through extrapolation. Actual results may vary. Users of this document should verify the applicable data for their specific environment.

Television output notice

The following notice applies to models that have the factory-installed television-output feature.

This product incorporates copyright protection technology that is protected by method claims of certain U.S. patents and other intellectual property rights owned by Macrovision Corporation and other rights owners. Use of this copyright protection technology must be authorized by Macrovision Corporation, and is intended for home and other limited viewing uses only unless otherwise authorized by Macrovision Corporation. Reverse engineering or disassembly is prohibited.

European conformance CE mark

The emission notices information is available in the *ThinkStation Safety and Warranty Guide* that came with your computer.



Trademarks

The following terms are trademarks of Lenovo in the United States, other countries, or both:

- Lenovo
- The Lenovo logo
- Rescue and Recovery
- ThinkStation
- ThinkVantage

Microsoft, Windows, and Windows Vista are trademarks of the Microsoft group of companies.

Intel and Xeon are trademarks of Intel Corporation in the United States, other countries, or both.

Linux is a trademark of Linus Torvalds in the United States, other countries, or both.

Other company, product, or service names may be trademarks or service marks of others.

Appendix C. WEEE and recycling information

Important WEEE Information

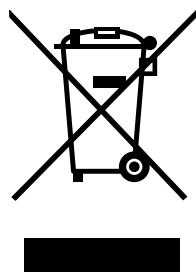

The WEEE marking on Lenovo products applies to countries with WEEE and e-waste regulations (for example, European Directive 2002/96/EC, India E-Waste Management & Handling Rules, 2011). Appliances are labeled in accordance with local regulations concerning waste electrical and electronic equipment (WEEE). These regulations determine the framework for the return and recycling of used appliances as applicable within each geography. This label is applied to various products to indicate that the product is not to be thrown away, but rather put in the established collective systems for reclaiming these end of life products.

Users of electrical and electronic equipment (EEE) with the WEEE marking must not dispose of end of life EEE as unsorted municipal waste, but use the collection framework available to them for the return, recycle, and recovery of WEEE and to minimize any potential effects of EEE on the environment and human health due to the presence of hazardous substances. For additional WEEE information go to: <http://www.lenovo.com/recycling>

Recycling information

Lenovo encourages owners of information technology (IT) equipment to responsibly recycle their equipment when it is no longer needed. Lenovo offers a variety of programs and services to assist equipment owners in recycling their IT products. For information on recycling Lenovo products, go to: <http://www.lenovo.com/recycling>

環境配慮に関して

本機器またはモニターの回収リサイクルについて

企業のお客様が、本機器が使用済みとなり廃棄される場合は、資源有効利用促進法の規定により、産業廃棄物として、地域を管轄する県知事あるいは、政令市長の許可を持った産業廃棄物処理業者に適正処理を委託する必要があります。また、弊社では資源有効利用促進法に基づき使用済みパソコンの回収および再利用・再資源化を行う「PC回収リサイクル・サービス」を提供しています。詳細は、<http://www.lenovo.com/recycling/japan>をご参照ください。

また、同法により、家庭で使用済みとなったパソコンのメーカー等による回収再資源化が2003年10月1日よりスタートしました。詳細は、<http://www.lenovo.com/recycling/japan>をご参照ください。

重金属を含む内部部品の廃棄処理について

本機器のプリント基板等には微量の重金属（鉛など）が使用されています。使用後は適切な処理を行うため、上記「本機器またはモニターの回収リサイクルについて」に従って廃棄してください。

Collecting and recycling a disused Lenovo computer or monitor

If you are a company employee and need to dispose of a Lenovo computer or monitor that is the property of the company, you must do so in accordance with the Law for Promotion of Effective Utilization of Resources. Computers and monitors are categorized as industrial waste and should be properly disposed of by an industrial waste disposal contractor certified by a local government. In accordance with the Law for Promotion of Effective Utilization of Resources, Lenovo Japan provides, through its PC Collecting and Recycling Services, for the collecting, reuse, and recycling of disused computers and monitors. For details, visit the Lenovo Web site at <http://www.lenovo.com/recycling/japan>. Pursuant to the Law for Promotion of Effective Utilization of Resources, the collecting and recycling of home-used computers and monitors by the manufacturer was begun on October 1, 2003. This service is provided free of charge for home-used computers sold after October 1, 2003. For details, visit the Lenovo Web site at <http://www.lenovo.com/recycling/japan>.

Disposing of Lenovo computer components

Some Lenovo computer products sold in Japan may have components that contain heavy metals or other environmental sensitive substances. To properly dispose of disused components, such as a printed circuit board or drive, use the methods described above for collecting and recycling a disused computer or monitor.

Disposing of disused lithium batteries from Lenovo computers

A button-shaped lithium battery is installed on the system board of your Lenovo computer to provide power to the computer clock while the computer is off or disconnected from the main power source. If you want to replace it with a new one, contact your place of purchase or ask for a repair service provided by Lenovo. If you have replaced it by yourself and want to dispose of the disused lithium battery, insulate it with vinyl tape, contact your place of purchase, and follow their instructions. If you use a Lenovo computer at home and need to dispose of a lithium battery, you must comply with local ordinances and regulations.

Recycling information for Brazil

Declarações de Reciclagem no Brasil

Descarte de um Produto Lenovo Fora de Uso

Equipamentos elétricos e eletrônicos não devem ser descartados em lixo comum, mas enviados à pontos de coleta, autorizados pelo fabricante do produto para que sejam encaminhados e processados por empresas especializadas no manuseio de resíduos industriais, devidamente certificadas pelos órgãos ambientais, de acordo com a legislação local.

A Lenovo possui um canal específico para auxiliá-lo no descarte desses produtos. Caso você possua um produto Lenovo em situação de descarte, ligue para o nosso SAC ou encaminhe um e-mail para: reciclar@lenovo.com, informando o modelo, número de série e cidade, a fim de enviarmos as instruções para o correto descarte do seu produto Lenovo.

Battery recycling information for Taiwan



廢電池請回收

Battery recycling information for the European Union

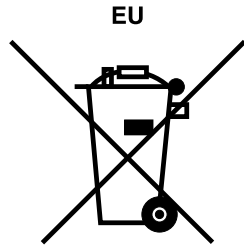

Notice: This mark applies only to countries within the European Union (EU).

Batteries or packaging for batteries are labeled in accordance with European Directive 2006/66/EC concerning batteries and accumulators and waste batteries and accumulators. The Directive determines the framework for the return and recycling of used batteries and accumulators as applicable throughout the European Union. This label is applied to various batteries to indicate that the battery is not to be thrown away, but rather reclaimed upon end of life per this Directive.

In accordance with the European Directive 2006/66/EC, batteries and accumulators are labeled to indicate that they are to be collected separately and recycled at end of life. The label on the battery may also include a chemical symbol for the metal concerned in the battery (Pb for lead, Hg for mercury, and Cd for cadmium). Users of batteries and accumulators must not dispose of batteries and accumulators as unsorted municipal waste, but use the collection framework available to customers for the return, recycling, and treatment of batteries and accumulators. Customer participation is important to minimize any potential effects of batteries and accumulators on the environment and human health due to the potential presence of hazardous substances. For proper collection and treatment, go to:
<http://www.lenovo.com/recycling>

Appendix D. Restriction of Hazardous Substances Directive (RoHS)

China RoHS

产品中有害有毒物质或元素的名称及含量

部件名称	有害有毒物质或元素					
	铅(Pb)	汞(Hg)	镉(Cd)	六价铬(Cr(VI))	多溴联苯(PBB)	多溴二苯醚(PBDE)
印刷电路板组件*	X	O	O	O	O	O
硬盘	X	O	O	O	O	O
光驱	X	O	O	O	O	O
内存	X	O	O	O	O	O
电脑I/O 附件	X	O	O	O	O	O
电源	X	O	O	O	O	O
键盘	X	O	O	O	O	O
鼠标	X	O	O	O	O	O
机箱/附件	X	O	O	O	O	O

○:表示该有害有毒物质在该部件所有均质材料中的含量均在SJ/T11363-2006标准规定的限量要求以下
 ×:表示该有害有毒物质至少在该部件的某一均质材料中的含量超出SJ/T11363-2006标准规定的限量要求
 表中标有“×”的所有部件都符合欧盟RoHS 法规。

印刷电路板组件*: 包括印刷电路板及其零部件、电容和连接器
 根据型号的不同,可能不会含有以上的所有部件,请以实际购买机型为准



在中华人民共和国境内销售的电子信息产品必须标识此标志,标志内的数字代表在正常使用状态下的产品的环保使用期限

Turkish RoHS

The Lenovo product meets the requirements of the Republic of Turkey Directive on the Restriction of the Use of Certain Hazardous Substances in Electrical and Electronic Equipment (EEE).

Türkiye EEE Yönetmeliğine Uygunluk Beyanı

Bu Lenovo ürünü, T.C. Çevre ve Orman Bakanlığı'nın "Elektrik ve Elektronik Eşyalarda Bazı Zararlı Maddelerin Kullanımının Sınırlandırılmasına Dair Yönetmelik (EEE)" direktiflerine uygundur.

EEE Yönetmeliğine Uygundur.

Ukraine RoHS

Цим підтверджуємо, що продукція Леново відповідає вимогам нормативних актів України, які обмежують вміст небезпечних речовин

India RoHS

RoHS compliant as per E-Waste (Management & Handling) Rules, 2011.

Index

A

- a rescue medium, creating and using 45
- Administrator password 50
- advanced settings 52
- antivirus software 6
- audio line-in connector 8
- audio line-out connector 8
- audio subsystem 2

B

- backup and recovery operations 42
- basic troubleshooting 61
- boot-block recovery 58

C

- changing
 - startup device sequence 51
- cleaning an optical mouse 64
- computer cover
 - removing 13
- computer cover, reinstalling 37
- connector description 8
- considerations, password 50
- creating
 - and using a rescue medium 45
- creating and using
 - recovery media 41
- CRU
 - completing the installation 37
- Customer Support Center 67

D

- device drivers 38
 - installing 46
 - reinstalling 46
- diagnostic programs, troubleshooting 61
- diagnostics programs, using 66
- documentation, using 66
- drivers, device 38

E

- environment, operating 4
- eSATA connector 8
- Ethernet 2
- Ethernet connector 8
- exiting, Setup Utility program 52
- expansion 2
- external options, installing 13

F

- failure, recovering from POST/BIOS 58
- features 1
- flashing the BIOS 57
- front fan assembly, replacing 32

G

- getting
 - help 65
 - information 65
 - service 65

H

- heat sink and fan assembly, replacing 29
- help
 - and service 66
 - getting 65

I

- IEEE 1394 connector 8
- important safety information iii
- information
 - getting 65
 - important safety iii
 - resources 65
 - safety 66
 - warranty 66
- Input/Output (I/O) features 2
- installing
 - device drivers 46
- installing options
 - memory module 17
 - PCI card 21
 - security features 38
- integrated cable lock, security 39
- internal drives 1

K

- keyboard, replacing 36

L

- Lenovo Solution Center 62
- Lenovo ThinkVantage Toolbox 62
- Lenovo ThinkVantage Tools 65

M

- media, creating and using recovery media 41
- memory module

- installing, replacing 17
- system board 17
- Microphone connector 8
- mouse, replacing 36

N

- notice, television output 74
- notices 73

O

- Online Books folder 65
- operations, backup and recovery 42
- optical mouse
 - cleaning 64
- Optical SPDIF in connector 8
- Optical SPDIF out connector 8

P

- parts replacement, completing 37
- password
 - Administrator password 50
 - considerations 50
 - setting, changing, deleting 50
 - user 50
- password protection 40
- PC-Doctor for Rescue and Recovery 63
- PCI card 21
 - installing, replacing 21
 - slots 21
- physical specifications 3
- power supply
 - features 3
- power-on self-test (POST) 57
- programs, updating system 57
- protection, password 40
- purchasing additional services 68

R

- rear fan assembly, replacing 34
- recovering
 - from a POST/BIOS update failure 58
 - software 41
- recovery
 - boot-block 58
 - operations, backup and 42
 - problems, solving 46
- recovery media, creating and using 41
- reinstalling
 - device drivers 46
- removing computer cover 13
- replacing
 - heat sink and fan assembly 29
- Rescue and Recovery 41
 - workspace, Rescue and Recovery 44
- Rescue and Recovery workspace 44
- resources, information 65

S

- safety iii
- safety information 66
- security
 - enabling or disabling 50
 - features 3, 38
 - integrated cable lock 39
- selecting
 - startup device 51
 - temporary startup device 51
- serial port 8
- service
 - and help 66
 - Customer Support Center 67
 - getting 65
- services
 - other 67
 - purchasing additional 68
- Set Administrator Password 50
- settings
 - advanced 52
 - changing 49
 - viewing 49
- Setup Utility program 49
- Setup Utility program, exiting 52
- Setup Utility program, starting 49
- software
 - recovering 41
- software overview 4
- solving recovery problems 46
- starting the Setup Utility program 49
- startup device 51
 - sequence, changing 51
 - temporary, selecting 51
- system
 - management 2
 - programs 57
- system board
 - locating parts 9
 - memory module 17

T

- television output notice 74
- temporary startup device 51
- the BIOS, updating (flashing) 57–58
- trademarks 74
- troubleshooting, basic 61
- troubleshooting, diagnostic programs 61

U

- updating
 - (flashing) the BIOS 57
 - system programs 57
- updating (flashing) the BIOS 58
- USB connector 8
- user, password 50
- using
 - a rescue medium, creating and 45

diagnostic programs 66
documentation 66
other services 67
passwords 49
Setup Utility program 49

V

video subsystem 1
viewing and changing settings 49

W

warranty information 66
workspace, backup and recovery 44

lenovo®

Part Number: 89Y7306

(1P) P/N: 89Y7306

