

PRIMERGY RX300 S6

Operating manual

Comments... Suggestions... Corrections...

The User Documentation Department would like to know your opinion of this manual. Your feedback helps us optimize our documentation to suit your individual needs.

Feel free to send us your comments by e-mail to [email: manuals@ts.fujitsu.com](mailto:manuals@ts.fujitsu.com).

Certified documentation according to DIN EN ISO 9001:2008

To ensure a consistently high quality standard and user-friendliness, this documentation was created to meet the regulations of a quality management system which complies with the requirements of the standard DIN EN ISO 9001:2008.

cognitas. Gesellschaft für Technik-Dokumentation mbH
www.cognitas.de

Copyright and Trademarks

Copyright © 2011 Fujitsu Technology Solutions GmbH.

All rights reserved.

Delivery subject to availability; right of technical modifications reserved.

All hardware and software names used are trademarks of their respective manufacturers.

- The contents of this manual may be revised without prior notice.
- Fujitsu assumes no liability for damages to third party copyrights or other rights arising from the use of any information in this manual.
- No part of this manual may be reproduced in any without the prior written permission of Fujitsu.

Microsoft, Windows, Windows Server, and Hyper V are trademarks or registered trademarks of Microsoft Corporation in the USA and other countries.

Intel and Xeon are trademarks or registered trademarks of Intel Corporation or its subsidiaries in the USA and other countries.

Before reading this manual

For your safety

This manual contains important information for safely and correctly using this product.

Carefully read the manual before using this product. Pay particular attention to the accompanying manual "Safety Notes and Regulations" and ensure these safety notes are understood before using the product. Keep this manual and the manual "Safety Notes and Regulations" in a safe place for easy reference while using this product.

Radio interference

This product is a "Class A" ITE (Information Technology Equipment). In a domestic environment this product may cause radio interference, in which case the user may be required to take appropriate measures. VCCI-A

Aluminum electrolytic capacitors

The aluminum electrolytic capacitors used in the product's printed circuit board assemblies and in the mouse and keyboard are limited-life components. Use of these components beyond their operating life may result in electrolyte leakage or depletion, potentially causing emission of foul odor or smoke.

As a guideline, in a normal office environment (25°C) operating life is not expected to be reached within the maintenance support period (5 years). However, operating life may be reached more quickly if, for example, the product is used in a hot environment. The customer shall bear the cost of replacing replaceable components which have exceeded their operating life. Note that these are only guidelines, and do not constitute a guarantee of trouble-free operation during the maintenance support period.

High safety use

This product has been designed and manufactured for general uses such as general office use, personal use, domestic use and normal industrial use. It has not been designed or manufactured for uses which demand an extremely high level of safety and carry a direct and serious risk to life or body if such safety cannot be ensured.

These uses include control of nuclear reactions in nuclear power plants, automatic airplane flight control, air traffic control, traffic control in mass transport systems, medical devices for life support, and missile guidance control in weapons systems (hereafter, "high safety use"). Customers should not use this product for high safety use unless measures are in place for ensuring the level of safety demanded of such use. Please consult the sales staff of Fujitsu if intending to use this product for high safety use.

Measures against momentary voltage drop

This product may be affected by a momentary voltage drop in the power supply caused by lightning. To prevent a momentary voltage drop, use of an AC uninterruptible power supply is recommended.

(This notice follows the guidelines of Voltage Dip Immunity of Personal Computer issued by JEITA, the Japan Electronics and Information Technology Industries Association.)

Technology controlled by the Foreign Exchange and Foreign Trade Control Law of Japan

Documents produced by Fujitsu may contain technology controlled by the Foreign Exchange and Foreign Trade Control Law of Japan. Documents which contain such technology should not be exported from Japan or transferred to non-residents of Japan without first obtaining authorization in accordance with the above law.

Harmonic Current Standards

This product conforms to harmonic current standard JIS C 61000-3-2.

Only for the Japanese market: About SATA hard disk drives

The SATA version of this server supports hard disk drives with SATA / BC-SATA storage interfaces. Please note that the usage and operation conditions differ depending on the type of hard disk drive used.

Please refer to the following internet address for further information on the usage and operation conditions of each available type of hard disk drive:

<http://primeserver.fujitsu.com/primergy/harddisk/>

Only for the Japanese market:



Although described in this manual, some sections do not apply to the Japanese market.



Contents

1	Preface	11
1.1	Concept and target groups for this manual	11
1.2	Documentation overview	12
1.3	Features	14
1.4	Notational conventions	25
1.5	Technical data	26
2	Installation steps, overview	29
3	Important information	31
3.1	Safety instructions	31
3.2	ENERGY STAR	39
3.3	CE conformity	39
3.4	FCC Class A Compliance Statement	40
3.5	Transporting the server	41
3.6	Notes on installing the server in the rack	42
3.7	Environmental protection	43
4	Hardware installation	45
4.1	Unpacking the server	46
4.2	Installing/removing the server in/from the rack	47
4.2.1	Rack system requirements	47
4.2.2	Installation in PRIMECENTER/DataCenter Rack	50
4.2.3	Installation in 3rd party racks	57
4.2.4	Installation in a telecommunication rack with 48 V DC power	59
4.3	Connecting devices to the server	60
4.4	Connecting the server to the power source	63

4.4.1	RX300 S6 to the mains	63
4.4.1.1	Connecting the power cord	63
4.4.1.2	Using cable ties	64
4.4.2	RX300 S6 CG to the direct current	65
4.4.2.1	Connecting the power cord	65
4.5	Notes on connecting/disconnecting cables	66
5	Starting up and operation	67

5.1	Controls and indicators	67
5.1.1	Front of server	67
5.1.1.1	Control elements	68
5.1.1.2	Indicators on the control panel	69
5.1.1.3	Indicators on the drives	71
5.1.2	Rear of server	73
5.1.3	Indicators of the hot-plug fans	78
5.2	Switching the server on and off	79
5.3	Configuring the server	82
5.3.1	Configuring the SAS/SATA RAID controller	82
5.3.2	Configuring the server and installing the operating system with the ServerView Installation Manager	83
5.3.3	Configuring the server and installing the operating system without the ServerView Installation Manager	84
5.4	Cleaning the server	85
6	Property and data protection	87

6.1	BIOS Setup security functions	87
7	Troubleshooting and tips	89

7.1	Power-on indicator remains unlit	89
7.2	Server switches itself off	90
7.3	Screen remains blank	90
7.4	Flickering stripes on monitor screen	91
7.5	No screen display or display drifts	91

7.6	Incorrect date and time	92
7.7	System will not boot	92
7.8	Drives reported as "dead" when starting system	92
7.9	Added drive reported as defective	93
7.10	Error message on screen	93
7.11	Expansion cards or onboard devices not recognized	93
7.12	Temperature warning	93
7.13	No effect of keyboard or mouse	94
7.14	Optical drive cannot read data	94
8	CSS components	95
<hr/>		
8.1	Hot-plug components	96
8.1.1	Hot-plug power supply units	96
8.1.1.1	Removing dummy module	97
8.1.1.2	Adding a hot-plug power supply unit	97
8.1.1.3	Replacing the hot-plug power supply unit	98
8.1.2	Hot-plug disk drives	100
8.1.2.1	3.5-inch HDD module and dummy module	101
8.1.2.2	2.5-inch HDD module and dummy module	102
8.1.2.3	2.5-inch SSD module	103
8.1.2.4	Handling drives and HDD/SSD modules	104
8.1.2.5	Removing/installing the dummy module	105
8.1.2.6	Installing the disk drive module	106
8.1.2.7	Removing the disk drive module	108
8.1.3	Replacing the hot-plug fan modules	109
8.1.3.1	Replacing the fan modules	110
8.2	Non-hot-plug components	112
8.2.1	Replacing a memory module	114
8.2.1.1	Removing the air duct	114
8.2.1.2	Removing a defective memory module	115
8.2.1.3	Installing a new memory module	115
8.2.1.4	Replacing the air duct and closing the server	116
8.2.2	Replacing an expansion card	117
8.3	Opening/closing the housing	119

9	Appendix: server specification	121
----------	---	------------

Index	125
------------------------	------------

1 Preface

The PRIMERGY RX300 S6 rack server is a universal and high-performance platform designed for a whole range of application areas in data center and server farm concepts. The system was developed specifically for configurations with multiple servers (clusters), front-end solutions, e-commerce applications and ERP solutions. The PRIMERGY RX300 S6 is ideal for applications and operational areas that require maximum scalability, performance and availability in a space-saving rack cabinet.

The PRIMERGY RX300 S6 offers a balanced architecture that incorporates next generation main memory (DDR3) and I/O technologies (PCIe Gen2). The backplanes for 6*3,5", 8*2,5" and 12*2,5" hard disk drives are already provided for SAS 2.0 and 6 Gbit/s SAS and the chipset prepared for the next generation of 6-core processors. High performance, scalability, impressive reliability and excellent extension options are combined in a powerful design.

The Cool-safe™ cooling concept with improved air flow cooling technology (honeycomb design) ensures the highest possible performance of the processors at work; at the same time, the system is extremely reliable thanks to the reduced heat dissipation.

The server occupies just two height units (HU) in the rack.

RX300 S6 also exists as "carrier grade" version for telecommunication application and will be called "RX300 S6 CG". This version is based on a 8*2,5" variant with one or two 48 V power supply and 10 fans implemented.

1.1 Concept and target groups for this manual

This operating manual describes how to install, set up and operate your server.

This operating manual is intended for those responsible for installing the hardware and ensuring that the system runs smoothly. It contains all the information you need to put your PRIMERGY RX300 S6 into operation.

To understand the various expansion options, you will need to be familiar with the fields of hardware and data transmission and you will require a basic knowledge of the underlying operating system.

1.2 Documentation overview

More information on your PRIMERGY RX300 S6 can be found in the following documents:

- "Quick Start Hardware - PRIMERGY RX300 S6" leaflet
"はじめにお読みください-PRIMERGY RX300 S6" for the Japanese market
(only included as a printed copy)
- "Quick Start Software - Quick Installation Guide" DVD booklet
(only included with the ServerView Suite as a printed copy) except for the Japanese market
- "Safety Notes and Regulations" manual
"安全上のご注意" for the Japanese market
- "Warranty" manual
"保証書" for the Japanese market
- "ServerView Suite Local Service Concept - LSC" manual
- "Returning used devices" manual and "Service Desk" leaflet
"サポート&サービス" for the Japanese market
- "PRIMERGY RX300 S6 Server Operating Manual"
- "PRIMERGY RX300 S6 Server Options Guide"
- "System Board D2619-N for PRIMERGY RX300 S6 Technical Manual"
- "D2619-N BIOS Setup Utility for PRIMERGY RX300 S6 and TX300 S6" manual



PRIMERGY manuals are available in PDF format on the ServerView Suite DVD 2. The ServerView Suite DVD 2 is part of the ServerView Suite supplied with every server.

If you no longer have the ServerView Suite DVDs, you can obtain the relevant current versions using the order number U15000-C289 (the order number for the Japanese market: please refer to the configurator of the server <http://primeserver.fujitsu.com/primergy/system.html>).

The PDF files of the manuals can also be downloaded free of charge from the Internet. The overview page showing the online documentation available on the Internet can be found using the URL (for EMEA market): <http://manuals.ts.fujitsu.com>. The PRIMERGY server documentation can be accessed using the *Industry standard servers* navigation option.

For the Japanese market please use the URL:
<http://primeserver.fujitsu.com/primergy/manual.html>.

Further sources of information:

- PRIMERGY Abbreviations and Glossary on the ServerView Suite DVD 2
- Manual for the monitor
- Documentation for the boards and drives
- Operating system documentation
- Information files in your operating system

1.3 Features

Customer Self Service (CSS)

The PRIMERGY Customer Self Service (CSS) concept enables you to identify and replace the affected component yourself in the case of certain error scenarios.

In the CSS concept, you can replace the following components yourself in the event of an error:

- Hot-plug hard disk drives
- Hot-plug power supply units
- Hot-plug system fan
- Memory modules
- Expansion cards

For information on replacing these components, see chapter "[CSS components](#)" on page 95.

CSS indicators on the control panel and on the back of the PRIMERGY server provide you with information if a CSS event arises (for more information on the behavior of these indicators, see chapter "[Starting up and operation](#)" on page 67 and the "ServerView Suite Local Service Concept - LSC" manual on the ServerView Suite DVD 2).

You can also fit your server with a ServerView Local Service Panel, which enables you to identify the type of component affected by the error directly on the server (for more information, see the "ServerView Suite Local Service Concept - LSC" manual on the ServerView Suite DVD 2).

In addition, CSS errors are displayed in the ServerView Operations Manager - the server management software from Fujitsu Technology Solutions.

In the event of errors, the ServerView Operations Manager refers you directly to the affected component and its order information in the Illustrated Spares catalog of the server in question. (This feature is not available for the Japanese market.)

System board

The features of the system board (D2619-N) are described in the technical manual for the system board in relation to the hardware and in the BIOS setup manual.

USB Flash Module (UFM) (option)

The system board is equipped with a UFM slot by the manufacturer.



The "internal USB stick" and "UFM" slots must not be used in parallel. Either an internal USB stick **or** a UFM may be used.

Trusted Platform Module (TPM)

A Trusted Platform Module (TPM) for safer storage of keys can be implemented as an option. This module enables programs from third party manufacturers to store key information (e.g. drive encryption using Windows Bitlocker Drive Encryption).

The TPM is activated via the BIOS system (for more information, refer to the "D2619-N BIOS Setup Utility for RX300 S6" manual).



CAUTION!

- When using the TPM, note the program descriptions provided by the third party manufacturers.
- You must also create a backup of the TPM content. To do this, follow the third party manufacturer's instructions. Without this backup, if the TPM or the system board is faulty you will not be able to access your data.
- If a failure occurs, please inform your service about the TPM activation before it takes any action, and be prepared to provide them with your backup copies of the TPM content.

Slots for expansion cards

The server can be flexibly expanded via seven slots (two PCIe Gen2 x8 and five PCIe Gen2 x4). PCIe Gen2 doubles the bandwidth of currently existing PCIe busses and allows improved system performance.

One of these slots (slot 1) is occupied with one of two possible SAS/SATA RAID controllers.

Features

Fujitsu Technology Solutions offers a unique patented solution to deliver the highest possible bandwidth with four PCIe Gen2 x8 slots: two of the four PCIe Gen2 x4 slots can each be used as PCIe Gen2 x8 slots if the neighboring slot is free.

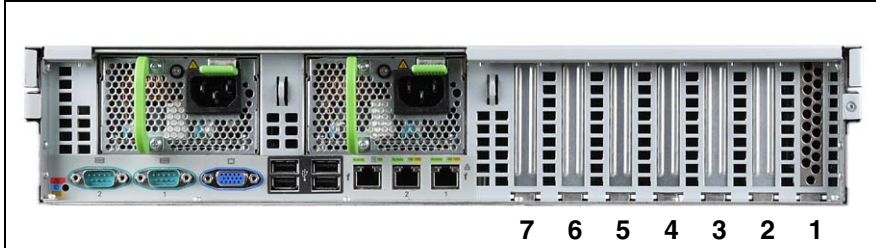

Figure 1: Slots for expansion cards - Basic Configuration

Seq. No.	Slot no.	Features
1	1	PCI express x4 (SAS/SATA RAID controller)
2	2	PCI express x4
3	3	PCI express x4 (x8 only when slot 2 remains empty)
4	4	PCI express x4
5	5	PCI express x4 (x8 only when slot 4 remains empty)
6	6	PCI express x8
7	7	PCI express x8

Table 1: Slots for expansion cards

Hard disk drives

The server is available in the following drive configurations:

- 6*3.5-inch SAS/SATA hard disk drives:
up to six (2x3) HDD modules, each with a 3.5-inch SAS/SATA hard disk drive with a maximum height of 1 inch. Slot for an optional 3.5-inch DAT or RDX drive.



Figure 2: RX300 S6 with 6*3.5-inch HDD modules

- 8*2.5-inch SAS/SATA hard disk drives:
up to eight (2x4) HDD modules, each with a 2.5-inch SAS/SATA hard disk drive with a maximum height of 15 mm. Slot for an optional 3.5-inch DAT or RDX drive.



Figure 3: RX300 S6 with 8*2.5-inch HDD modules

- 12*2.5-inch SAS/SATA hard disk drives:
up to twelve (3x4) HDD modules, each with a 2.5-inch SAS/SATA hard disk drive with a maximum height of 15 mm.



Figure 4: RX300 S6 with 12*2.5-inch HDD modules

Features

The module is connected to the SAS/SATA backplane without cables. This allows HDD modules to be simply plugged in or pulled out (for further details see [section "Hot-plug disk drives" on page 100](#)).

The hard disk subsystem is designed for SAS/SATA, each with one channel for each hard disk drive.

If the server has a RAID configuration, the HDD modules can be exchanged during operation (hot-swap).

SAS/SATA RAID controller

The server is available with the following SAS/SATA RAID controllers for operating the internal SAS/SATA hard disk drives:

- Modular RAID 0/1 controller with "Integrated Mirroring Enhanced" (SAS IME) for SAS1.0

RAID levels 0, 1 and 1E are supported for internal hard disk drive configurations.



For the Japanese market only RAID level 1 is supported for internal hard disk drive configurations.

- Modular RAID 0/1 controller with "MegaRAID functionality" (SAS MegaRAID) for SAS1.0 and SAS2.0

RAID levels 0, 1, 10 and 1E are supported for internal hard disk drive configurations.

- Modular RAID 5/6 controller with "MegaRAID functionality" (SAS MegaRAID) for SAS1.0 and SAS2.0

RAID levels 0, 1, 10, 1E, 5, 50, 6 and 60 are supported for internal hard disk drive configurations. As an option, a battery backup unit (BBU) can save the memory content even if the power fails. Cache memory size of 512 Mbyte is available.



For more information on configuring the controller, see [section "Configuring the server" on page 82](#).

Further information on SAS/SATA RAID controllers is provided in the "Modular RAID Controller Installation Guide" (on ServerView Suite DVD 2 under *Industry Standard Servers - Expansion Cards - Storage Adapters - LSI RAID / SCSI Controllers*).

Further information on other SAS/SATA RAID controllers (e.g. for operating external SAS/SATA hard disk drives or tape drives) is available on ServerView Suite DVD 2 under *Industry Standard Servers - Expansion Cards - Storage Adapters - LSI RAID / SCSI Controllers*.

Accessible drives/components

A number of mounting locations are available:

- One 3.5-inch slimline bay for an optional Local Service Module:
ServerView Local Service Display (LSD) or
ServerView Local Service Panel (LSP)
- One 3.5-inch slimline bay for an optional optical drive

For a configuration with 3.5-inch HDD modules, an optional DAT or RDX drive can be installed in the right-hand drive cage. This means that the top two bays of the drive cage are occupied and are no longer available for HDD modules.

For the configuration with 8*2.5-inch HDD modules, an optional 3.5-inch DAT or RDX drive can be installed next to the right-hand drive cage.



The accessible drives/components described in this section cannot be replaced during operation.

USB connector (external)

Three USB connectors on the front of the device support activities carried out by the service technician. The maximum length of the external cable is two meters for the USB connectors on the front.

Another four USB connectors are available on the rear of the device.

USB connectors (internal)

Additional USB connectors are available on the system board: one is for an optional DAT drive or an optional RDX drive. Other connector can be used for either a UFM or a USB stick.

Power supply

In its basic configuration, the server has a hot-pluggable power supply unit that adjusts automatically to any power voltage in the range from 100 V to 240 V. As an option, the power supply can be expanded with an extra power supply unit to create a redundant power supply. If a power supply unit fails, the redundant configuration assures continued operation. The defective power supply unit can be replaced during operation (for further details see [section "Hot-plug power supply units" on page 96](#)).



For the RX300 S6 CG the server has a hot-pluggable power supply unit that adjusts automatically to any power voltage in the range from 40.5 V to 57 V.

Cooling

The Cool-safe™ cooling concept with improved air flow cooling technology (honeycomb design) ensures the highest possible performance of the processors at work; at the same time, the system is extremely reliable thanks to the reduced heat dissipation.

The server is equipped with five separate hot-plug fan modules. The redundant fan configuration allows one fan to fail and the system still works. To ensure the redundancy of the fan system the faulty fan has to be replaced immediately.

Defective fans can be replaced during operation (for further details see ["Replacing the hot-plug fan modules" on page 109](#)).

Each processor has a heat sink.

High level of availability and data security

When memory data is accessed, 1-bit errors are identified in the main memory and automatically corrected with the error correcting code (ECC) method. The patented memory scrubbing function regularly starts up the EDC mechanism, ensuring continuous data integrity.

The memory modules used support SDDC technology (Chipkill™), which further increases the effectiveness of memory error monitoring and correction.

Hot-spare memory technology is also supported, whereby one memory module is used as a replacement for two other memory modules. If a memory module fails, the module with the defective memory is deactivated automatically and the replacement module is activated (provided that it has been configured accordingly in BIOS; see *BIOS Setup*). The deactivated memory module is no longer used and the faulty memory module can be replaced at the next opportunity. In order to use the hot-spare memory function, all occupied memory spaces in a channel must have an identical memory configuration.

Memory modules can be protected against failure by mirroring (Memory Mirroring). Memory Mirroring is roughly comparable to RAID level 1 for hard disk arrays.



For further information according to memory module population please refer to the technical manual of the system board D2619-N.

ASR&R (Automatic Server Reconfiguration and Restart) restarts the system in the event of an error and automatically "hides" the defective system components.

The PDA (Prefailure Detection and Analysing) technology from Fujitsu analyzes and monitors all components that are critical for system reliability.

The RAID functionality of the SAS RAID controller supports RAID levels 0, 1, 10, 1E, 5, 50, 6 und 60 and increases the availability of the system.

The hot-plug HDD modules provide additional availability.

iRMC S2 with integrated management LAN connector



The features of the iRMC S2 Advanced Video Redirection and Remote Storage are available as an option.

The iRMC S2 (integrated **R**emote **M**anagement **C**ontroller) is a BMC with integrated management LAN connector and expanded functionality that was previously only available with additional plug-in cards. In this way, the iRMC S2 enables complete control of PRIMERGY servers, regardless of system status, and thus particularly the control of PRIMERGY servers that are in the "out-of-band" system status.

Major functions supported by the iRMC S2 include the following:

- Browser access via iRMC S2-s own Web server
- Secure communication (SSH, SSL)
- Power Management for the managed server (depending on its system status)
- Power Consumption Management
- Connecting virtual drives as remote storage
- Text-based and graphic console bypass (Advanced Video Redirection)
- Command Line Interface (CLI)
- Simple, interactive or script-based iRMC S2 configuration
- Customer Self Service (CSS)
- iRMC S2-s own user management
- Multi-computer, global iRMC S2 user administration using an LDAP Directory Service
- Automatic network configuration via DNS / DHCP
- Power supply of the iRMC S2 via the system standby supply
- Full-coverage alarm management
- System Event Log (SEL) reading and processing

More information about the iRMC S2 can be found in the "iRMC S2 - integrated Remote Management Controller" user's guide (on the ServerView Suite DVD 2 under *Industry Standard Servers - Software - ServerView Suite - Out-Of-Band Management*).

Server management

Server management is implemented using the ServerView Operations Manager supplied and the PDA (Prefailure Detection and Analysis) technology from Fujitsu. PDA reports the threat of a system error or overload at an early stage, allowing preventive measures to be taken.

The ServerView Operations Manager enables the management of all PRIMERGY servers in the network via a central console. The ServerView Operations Manager supports the following functions:

- Round-the-clock monitoring, regardless of server status
- High-performance, graphical console bypass (AVR) protected by HTTPS/SSL (128 bit)
- Remote storage via USB
- Remote power on
- Intrusion detection in the floorstand model
- Temperature monitoring of the CPU and the surrounding area
- Detailed status and error reports for processors and main memory
- Watchdog timer for Automatic Server Reconfiguration and Restart (ASR&R) in the event that memory modules or processors fail
- Power monitoring
- End-of-life monitoring of fans with prompt notification before failure
- Watchdog timer for monitoring the operating system with ASR&R

Further information on the ServerView Operations Manager is provided in the associated documentation.

ServerView Installation Manager

You can configure the PRIMERGY server quickly and precisely with the ServerView Installation Manager software provided. User-guided menus are available for installing the server operating system (for further details see section "[Configuring the server](#)" on page 82).

Service and support

PRIMERGY servers are easy to maintain and modular, thus enabling quick and simple maintenance.

The handles and locks (touch point) used to exchange components are colored green to ensure simple and immediate recognition.

In order to prevent the components from being damaged by incorrect handling when they are being installed and removed, the areas of all components that can be touched without damaging them are also marked green.

PRIMERGY diagnostic LEDs fitted on the system board show which component (memory module, processor, fan or expansion card) is not functioning properly.

The Flash EPROM program supplied with the Fujitsu utilities supports a fast BIOS update.

With the iRMC S2 (integrated Remote Management Controller) on the system board, the PRIMERGY RX300 S6 server can also be maintained and serviced remotely. This enables remote diagnosis for system analysis, remote configuration and remote restart should the operating system or hardware fail.

ServerView Remote Management

ServerView Remote Management is the remote management solution from Fujitsu for PRIMERGY servers. ServerView Remote Management and the relevant hardware components integrated on the system board allow remote monitoring and maintenance as well as fast restoration of operation in the event of errors.

Remote monitoring and maintenance avoids time-consuming and costly on-site repairs and reduces service costs. This leads to a reduction in the total cost of ownership and an excellent return on investment for the remote management solution.

The administrator can access all system information and information from the sensors such as fan speeds or voltages via the iRMC S2's Web interface (see section "[iRMC S2 with integrated management LAN connector](#)" on page 22). You can also start the text-based or graphic console bypass (Advanced Video Redirection, AVR) and connect virtual drives as remote storage.





The features of the iRMC S2 Advanced Video Redirection and Remote Storage are available as an option.

More information about the iRMC S2 can be found in the "iRMC S2 - integrated Remote Management Controller" user's guide (on the ServerView Suite DVD 2 under *Industry Standard Servers - Software - ServerView Suite - Out-Of-Band Management*).

1.4 Notational conventions

The following notational conventions are used in this manual:

<i>Text in italics</i>	indicates commands or menu items.
"Quotation marks"	indicate names of chapters and terms that are being emphasized.
▶	describes activities that must be performed in the order shown.
 CAUTION!	pay particular attention to texts marked with this symbol. Failure to observe this warning may endanger your life, destroy the system or lead to the loss of data.
	indicates additional information, notes and tips.

1.5 Technical data

Electrical data (hot-plug power supply unit)

Rated voltage range	100 V - 240 V
Frequency	50 Hz - 60 Hz
Rated current with basic configuration	4.2 A - 1.4 A / 100 V - 240 V
Max. rated current	8.0 A - 3.5 A / 100 V - 240 V
Effective power	800 W
Apparent power	733 VA
Heat dissipation	2638.8 kJ/h (2501.7 btu/h)
Main power fuse	16 A
Protection class	I

Electrical data (hot-plug power supply unit -48 V for CG)

Rated voltage range	40.5 V - 57 V
Frequency	DC
Max. rated current with basic configuration	23.8 A - 16.4 A / 40.5 V - 57 V
Effective power	800 W

Compliance with regulations and standards

Product safety	IEC 60950-1/2, EN 60950-1/2, UL/CSA 60950-1/2, CNS 14336 / GB 4943 / EN 50371
Ergonomics	IK1 ITB2000:2009
Electromagnetic compatibility	FCC class A CNS 13438 class A, VCCI class A AS/NZS CISPR 22 class A / GB 9254 class A GB 17625, KN22
interference emissions	EN 55022 class A, EN 300386, KN29
Harmonic current	EN 61000-3-2
Flicker	EN 61000-3-3
interference immunity	EN 55024, EN 300386
CE marking to EU directives	Low Voltage Directive 2006/95/EC (product safety) Electromagnetic compatibility 2004/108/EC

Technical data

Mechanical values

Width	482.4 mm
Depth	770 mm
Height	85.9 mm or 2HU
Installation depth in rack	735 mm
Cable depth in rack	100 mm (1000 mm rack recommended)

Weight

Approx. 25 kg (depending on configuration).

Ventilation clearance

At least 200 mm on the front and rear.

Environmental conditions

Environment class 3K2 Environment class 2K2 Environment class 3.1	EN 60721 / IEC 721 part 3-3 EN 60721 / IEC 721 part 3-2 ETX 300-019-2-3; T3.1
Temperature: Operating (3K2) Transport (2K2)	10°C35°C - 25°C 60°C
Humidity	10% 85%
Mechanical environmental conditions	Operating: EN 60721-3-3; class 3M2 Transport: EN 60721-3-2; class 2M2

Condensation must be avoided during operation.

Noise level

Sound power level $L_{WA,d}$ (ISO 9296)	< 6.2 B (standby) < 6.2 B (operation)
Sound pressure level at adjacent workstation L_{pAm} (ISO 9296)	< 45 dB(A) (standby) < 45 dB(A) (operation)

2 Installation steps, overview

This chapter contains an overview of the steps necessary to install your server. Links take you to sections where you can find more detailed information about the respective steps:

- ▶ First of all, carefully read the safety instructions in ["Important information" on page 31](#) and following.
- ▶ Unpack the system, check the contents of the package for visible transport damage and check whether the items delivered correspond to the details on the delivery note (see ["Unpacking the server" on page 46](#)).
- ▶ The server includes loose parts. Keep these parts in a safe place. They are designed to be used for installing optional components at a later time.
- ▶ Transport the server to the place where you want to set it up.
- ▶ Make sure that you have all necessary manuals (see ["Documentation overview" on page 12](#)); print out the PDF files if required.
- ▶ Mount the server into the rack (see ["Installing/removing the server in/from the rack" on page 47](#)).
- ▶ Wire the server. To do this, refer to sections ["Connecting devices to the server" on page 60](#) and ["Notes on connecting/disconnecting cables" on page 66](#).
- ▶ Connect the server to the mains (see ["Connecting the server to the power source" on page 63](#)).
- ▶ Familiarize yourself with the controls and indicators on the front and rear of the server (see section ["Controls and indicators" on page 67](#)).

-
- ▶ Configure the server and install the desired operating system and applications. The following options are available:

- Remote installation with the ServerView Installation Manager:

With the ServerView Suite DVD 1 provided, you can configure the server and install the operating system in a convenient manner.

Details on how to operate the ServerView Installation Manager, as well as some additional information, are included in the "ServerView Suite Installation Manager" user's guide (on ServerView Suite DVD 2 under *Industry Standard Servers - Software - ServerView Suite - Server Installation and Deployment*).

Configuration information can also be found in section "[Configuring the server and installing the operating system with the ServerView Installation Manager](#)" on page 83.

- Local configuration and installation with or without the ServerView Installation Manager (see section "[Configuring the server and installing the operating system with the ServerView Installation Manager](#)" on page 83 or section "[Configuring the server and installing the operating system without the ServerView Installation Manager](#)" on page 84).



You will find more information on installing the server remotely or locally in the "ServerView Suite Installation Manager" user's guide (on the ServerView Suite DVD 2 under *Industry Standard Servers - Software - ServerView Suite - Server Installation and Deployment*).

3 Important information

In this chapter you will find essential information regarding safety when working on your server.

3.1 Safety instructions



The following safety instructions are also provided in the manual "Safety Notes and Regulations" or "安全上のご注意".

This device meets the relevant safety regulations for IT equipment. If you have any questions about whether you can install the server in the intended environment, please contact your sales outlet or our customer service team.



CAUTION!

- The actions described in this manual shall be performed by technical specialists. A technical specialist is a person who is trained to install the server including hardware and software.
- Repairs to the device that do not relate to CSS failures shall be performed by service personnel. Please note that unauthorized interference with the system will void the warranty and exempt the manufacturer from all liability.
- Any failure to observe the guidelines in this manual, and any improper repairs could expose the user to risks (electric shock, energy hazards, fire hazards) or damage the equipment.
- Before installing/removing internal options to/from the server, turn off the server, all peripheral devices, and any other connected devices. Also unplug all power cords from the power outlet. Failure to do so can cause electric shock.

Before starting up



CAUTION!

- During installation and before operating the device, observe the instructions on environmental conditions for your device.
- If the device is brought in from a cold environment, condensation may form both inside and on the outside of the device.

Wait until the device has acclimatized to room temperature and is absolutely dry before starting it up. Material damage may be caused to the device if this requirement is not observed.

- Transport the device only in the original packaging or in packaging that protects it from knocks and jolts.

Installation and operation



CAUTION!

- This unit should not be operated in ambient temperatures above 35 °C.
- If the unit is integrated into an installation that draws power from an industrial power supply network with an IEC309 connector, the power supply's fuse protection must comply with the requirements for non-industrial power supply networks for type A connectors.
- The unit automatically adjusts itself to a mains voltage in a range of 100 V - 240 V. Ensure that the local mains voltage lies within these limits.
- This device must only be connected to properly grounded power outlets or insulated sockets of the rack's internal power supply with tested and approved power cords.
- Ensure that the device is connected to a properly grounded power outlet close to the device.



CAUTION!

- Ensure that the power sockets on the device and the properly grounded power outlets are freely accessible.
- The On/Off button or the main power switch (if present) does not isolate the device from the mains power supply. To disconnect it completely from the mains power supply, unplug all network power plugs from the properly grounded power outlets.
- Always connect the server and the attached peripherals to the same power circuit. Otherwise you run the risk of losing data if, for example, the server is still running but a peripheral device (e.g. memory subsystem) fails during a power outage.
- Data cables must be adequately shielded.
- Ethernet cabling has to comply with EN 50173 and EN 50174-1/2 standards or ISO/IEC 11801 standard respectively. The minimum requirement is a Category 5 shielded cable for 10/100 Ethernet, or a Category 5e cable for Gigabit Ethernet.
- Route the cables in such a way that they do not create a potential hazard (make sure no-one can trip over them) and that they cannot be damaged. When connecting the server, refer to the relevant instructions in this manual.
- Never connect or disconnect data transmission lines during a storm (risk of lightning hazard).
- Make sure that no objects (e.g. jewelry, paperclips etc.) or liquids can get inside the server (risk of electric shock, short circuit).
- In emergencies (e.g. damaged casing, controls or cables, penetration of liquids or foreign bodies), switch off the server immediately, remove all power plugs and contact your sales outlet or customer service team.



CAUTION!

- Proper operation of the system (in accordance with IEC 60950-1/2 resp. EN 60950-1/2) is only ensured if the casing is completely assembled and the rear covers for the installation slots have been fitted (electric shock, cooling, fire protection, interference suppression).
- Only install system expansions that satisfy the requirements and rules governing safety and electromagnetic compatibility and those relating to telecommunication terminals. If you install other expansions, they may damage the system or violate the safety regulations. Information on which system expansions are approved for installation can be obtained from our customer service center or your sales outlet.
- The components marked with a warning notice (e.g. lightning symbol) may only be opened, removed or exchanged by authorized, qualified personnel. Exception: CSS components can be replaced.
- The warranty is void if the server is damaged during installation or replacement of system expansions.
- Only set screen resolutions and refresh rates that are specified in the operating manual for the monitor. Otherwise, you may damage your monitor. If you are in any doubt, contact your sales outlet or customer service center.
- Before installing/removing internal options to/from the server, turn off the server, all peripheral devices, and any other connected devices. Also unplug all power cords from the outlet. Failure to do so can cause electric shock.
- Do not damage or modify internal cables or devices. Doing so may cause a device failure, fire, or electric shock.
- Devices inside the server remain hot after shutdown. Wait for a while after shutdown before installing or removing internal options.
- The circuit boards and soldered parts of internal options are exposed and can be damaged by static electricity. Before handling them, first touch a metal part of the server to discharge static electricity from your body.
- Do not touch the circuitry on boards or soldered parts. Hold the metallic areas or the edges of the circuit boards.



CAUTION!

- Install the screw removed during installation/detaching Internal Options in former device/position. To use a screw of the different kind causes a breakdown of equipment.
- The installation indicated on this note is sometimes changed to the kind of possible options without notice.

Batteries



CAUTION!

- Incorrect replacement of batteries may lead to a risk of explosion. The batteries may only be replaced with identical batteries or with a type recommended by the manufacturer (see the technical manual for the system board).
- Do not throw batteries into the trash can.
- Batteries must be disposed of in accordance with local regulations concerning special waste.
- Replace the lithium battery on the system board in accordance with the instructions in the technical manual for the system board.
- All batteries containing pollutants are marked with a symbol (a crossed-out garbage can). In addition, the marking is provided with the chemical symbol of the heavy metal decisive for the classification as a pollutant:

Cd Cadmium

Hg Mercury

Pb Lead

Working with CDs/DVDs/BDs and optical drives

When working with devices with optical drives, these instructions must be followed.



CAUTION!

- Only use CDs/DVDs/BDs that are in perfect condition, in order to prevent data loss, equipment damage and injury.
- Check each CD/DVD/BD for damage, cracks, breakages etc. before inserting it in the drive.

Note that any additional labels applied may change the mechanical properties of a CD/DVD/BD and cause imbalance.

Damaged and imbalanced CDs/DVDs/BDs can break at high drive speeds (data loss).

Under certain circumstances, sharp CD/DVD/BD fragments can pierce the cover of the optical drive (equipment damage) and can fly out of the device (danger of injury, particularly to uncovered body parts such as the face or neck).

- High humidity and airborne dust levels are to be avoided. Electric shocks and/or server failures may be caused by liquids such as water, or metallic items, such as paper clips, entering a drive.
- Shocks and vibrations are also to be avoided.
- Do not insert any objects other than the specified CDs/DVDs/BDs.
- Do not pull on, press hard, or otherwise handle the CD/DVD/BD tray roughly.
- Do not disassemble the optical drive.
- Before use, clean the optical disk tray using a soft, dry cloth.
- As a precaution, remove disks from the optical drive when the drive is not to be used for a long time. Keep the optical disk tray closed to prevent foreign matter, such as dust, from entering the optical drive.
- Hold CDs/DVDs/BDs by their edges to avoid contact with the disk surface.

- Do not contaminate the CD/DVD/BD surface with fingerprints, oil, dust, etc. If dirty, clean with a soft, dry cloth, wiping from the center to the edge. Do not use benzene, thinners, water, record sprays, antistatic agents, or silicone-impregnated cloth.
- Be careful not to damage the CD/DVD/BD surface.
- Keep the CDs/DVDs/BDs away from heat sources.
- Do not bend or place heavy objects on CDs/DVDs/BDs.
- Do not write with ballpoint pen or pencil on the label (printed) side.
- Do not attach stickers or similar to the label side. Doing so may cause rotational eccentricity and abnormal vibrations.
- When a CD/DVD/BD is moved from a cold place to a warm place, moisture condensation on the CD/DVD/BD surface can cause data read errors. In this case, wipe the CD/DVD/BD with a soft, dry cloth in a radial way then let it air dry. Do not dry the CD/DVD/BD using devices such as a hair dryer.
- To avoid dust, damage, and deformation, keep the CD/DVD/BD in its case whenever it is not in use.
- Do not store CDs/DVDs/BDs at high temperatures. Areas exposed to prolonged direct sunlight or near heating appliances are to be avoided.



You can prevent damage from the optical drive and the CDs/DVDs/BDs, as well as premature wear of the disks, by observing the following suggestions:

- Only insert disks in the drive when needed and remove them after use.
- Store the disks in suitable sleeves.
- Protect the disks from exposure to heat and direct sunlight.

Laser information

The optical drive complies with IEC 60825-1 laser class 1.



CAUTION!

The optical drive contains a light-emitting diode (LED), which under certain circumstances produces a laser beam stronger than laser class 1. Looking directly at this beam is dangerous.

Never remove parts of the optical drive casing!

Modules with Electrostatic-Sensitive Devices

Modules with electrostatic-sensitive devices are identified by the following sticker:

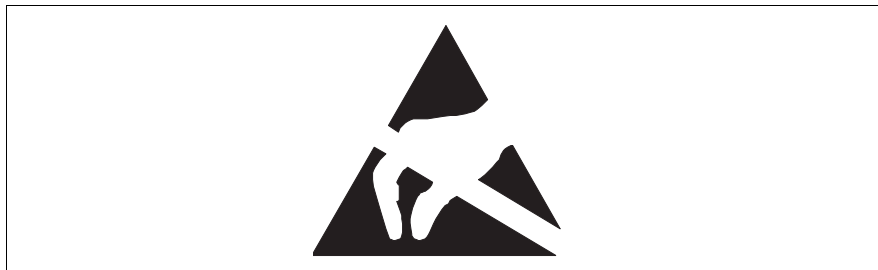

Figure 5: ESD label

When you handle components fitted with ESDs, you must always observe the following points:

- Switch off the system and remove the power plugs from the power outlets before installing or removing components with ESDs.
- You must always discharge static build-up (e.g. by touching a grounded object) before working with such components.
- Any devices or tools that are used must be free of electrostatic charge.
- Wear a suitable grounding cable that connects you to the external chassis of the system unit.
- Always hold components with ESDs at the edges or at the points marked green (touch points).
- Do not touch any connectors or conduction paths on an ESD.
- Place all the components on a pad which is free of electrostatic charge.



For a detailed description of how to handle ESD components, see the relevant European or international standards (EN 61340-5-1, ANSI/ESD S20.20).

Other important information:

- When cleaning the device, please observe the relevant notes in [section "Cleaning the server" on page 85](#).
- Keep this operating manual and the other documentation (such as the Technical Manual, DVD) close to the device. All documentation must be included if the equipment is passed on to a third party.

3.2 ENERGY STAR



Products that have been certified compliant with ENERGY STAR and identified as such are in full compliance with the specification at shipping. Note that energy consumption can be affected by software that is installed or any changes that are made to the hardware configuration or BIOS or energy options subsequently. In such cases, the properties guaranteed by ENERGY STAR can no longer be assured.

The "ServerView Operations Manager" user guide contains instructions for reading out measurement values, including those relating to current energy consumption and air temperatures. Either the Performance Monitor or the Task Manager can be used to read out CPU utilization levels.

3.3 CE conformity



The system complies with the requirements of the EC directives 2004/108/EC regarding "Electromagnetic Compatibility" and 2006/95/EC "Low Voltage Directive". This is indicated by the CE marking (CE = Communauté Européenne).

3.4 FCC Class A Compliance Statement

If there is an FCC statement on the device, it applies to the products covered in this manual, unless otherwise specified herein. The statement for other products will appear in the accompanying documentation.

NOTE:

This equipment has been tested and found to comply with the limits for a "Class A" digital device, pursuant to Part 15 of the FCC rules and meets all requirements of the Canadian Interference-Causing Equipment Standard ICES-003 for digital apparatus. These limits are designed to provide reasonable protection against harmful interference in a residential installation. This equipment generates, uses and can radiate radio frequency energy and, if not installed and used in strict accordance with the instructions, may cause harmful interference to radio communications. However, there is no warranty that interference will not occur in a particular installation. If this equipment does cause harmful interference to radio or television reception, which can be determined by turning the equipment off and on, the user is encouraged to try to correct the interference by one or more of the following measures:

- Reorient or relocate the receiving antenna.
- Increase the separation between equipment and the receiver.
- Connect the equipment into an outlet on a circuit different from that to which the receiver is connected.
- Consult the dealer or an experienced radio/TV technician for help.

Fujitsu is not responsible for any radio or television interference caused by unauthorized modifications of this equipment or the substitution or attachment of connecting cables and equipment other than those specified by Fujitsu. The correction of interferences caused by such unauthorized modification, substitution or attachment will be the responsibility of the user.

The use of shielded I/O cables is required when connecting this equipment to any and all optional peripheral or host devices. Failure to do so may violate FCC and ICES rules.

WARNING:

This is a class A product. In a domestic environment this product may cause radio interference in which case the user may be required to take adequate measures.

3.5 Transporting the server



CAUTION!

Only transport the server in its original packaging or in packaging that protects it from impacts and jolts. Do not unpack the server until it is at its installation location.

If you need to lift or transport the server, ask other people to help you.

Never lift or carry the device by the handles on the front panel.

3.6 Notes on installing the server in the rack



CAUTION!

- **For safety reasons, at least two people are required to install the server in the rack because of its weight and size.**

(For the Japanese market, please refer to "安全上の注意およびその他の重要情報".)

- Never lift the server into the rack using the handles on the front panel.
- When connecting and disconnecting cables, observe the relevant instructions in the "Important Information" chapter of the technical manual for the corresponding rack. The technical manual is supplied with the corresponding rack.
- When installing the rack, make sure that the anti-tilt mechanism is correctly fitted.
- For safety reasons, no more than one unit may be removed from the rack at any one time during installation and maintenance work.
- If several units are simultaneously removed from the rack, there is a risk that the rack could tip over.
- The rack must be connected to the power supply by an authorized specialist (electrician).
- If the server is integrated into an installation that draws power from an industrial power supply network with an IEC309 type connector, the power supply's fuse protection must comply with the requirements for non-industrial power supply networks for the type A connector.

3.7 Environmental protection

Environmentally-friendly product design and development

This product has been designed in accordance with the Fujitsu standard for "environmentally friendly product design and development". This means that key factors such as durability, selection and labeling of materials, emissions, packaging, ease of dismantling and recycling have been taken into account.

This saves resources and thus reduces the harm done to the environment. Further information can be found at:

- http://ts.fujitsu.com/products/standard_servers/index.html (for the EMEA market)
- <http://primeserver.fujitsu.com/primergy/concept/> (for the Japanese market)

Energy-saving information

Devices that do not need to be constantly switched on should be switched off until they are needed as well as during long breaks and after completion of work.

Packaging information

This packaging information doesn't apply to the Japanese market.

Do not throw away the packaging. You may need it later for transporting the system. If possible, the equipment should only be transported in its original packaging.

Information on handling consumables

Please dispose of printer consumables and batteries in accordance with the applicable national regulations.

In accordance with EU directives, batteries must not be disposed of with unsorted domestic waste. They can be returned free of charge to the manufacturer, dealer or an authorized agent for recycling or disposal.

Environmental protection

All batteries containing pollutants are marked with a symbol (a crossed-out garbage can). They are also marked with the chemical symbol for the heavy metal that causes them to be categorized as containing pollutants:

Cd Cadmium

Hg Mercury

Pb Lead

Labels on plastic casing parts

Please avoid sticking your own labels on plastic parts wherever possible, since this makes it difficult to recycle them.

Returns, recycling and disposal

Please handle returns, recycling and disposal in accordance with local regulations.



The device must not be disposed of with domestic waste. This device is labeled in compliance with European directive 2002/96/EC on waste electrical and electronic equipment (WEEE).

This directive sets the framework for returning and recycling used equipment and is valid across the EU. When returning your used device, please use the return and collection systems available to you. Further information can be found at

<http://ts.fujitsu.com/recycling>.

Details regarding the return and recycling of devices and consumables within Europe can also be found in the "Returning used devices" manual, via your local Fujitsu branch or from our recycling center in Paderborn:

Fujitsu Technology Solutions
Recycling Center
D-33106 Paderborn

Tel. +49 5251 525 1410

Fax +49 5251 525 32 1410

4 Hardware installation



CAUTION!

- Follow the safety instructions in the chapter "[Important information](#)" on page 31.
- Do not expose the server to extreme environmental conditions (see "[Technical data](#)" on page 26). Protect the server from dust, humidity and heat.
- Make sure that the server is acclimatized for the time indicated in this table before putting it into operation.

Temperature difference (°C)	Minimum acclimatization time (hours)
5	3
10	5
15	7
20	8
25	9
30	10

Table 2: Acclimatization time

In the [table "Acclimatization time"](#), the temperature difference refers to the difference between the operating environment temperature and the temperature to which the server was exposed previously (outside, transport or storage temperature).

4.1 Unpacking the server



CAUTION!

Follow the safety instructions in ["Important information" on page 31](#).

The server must always be lifted or carried by at least two people.
(For the Japanese market, please refer to "安全上の注意".)

Do not unpack the server until it is at its installation location.

- ▶ Transport the server to the place where you want to set it up.
- ▶ Unpack all individual parts.

Keep the original packaging in case you want to transport the server again
(applies only to EMEA market).

- ▶ Check the delivery for any damage during transport.
- ▶ Check whether the items delivered match the details on the delivery note.

The product name and serial number of the product can be found on the ID card
(see section ["Front of server" on page 67](#)).

- ▶ Notify your supplier immediately should you discover that the items delivered do not correspond to the delivery note.

4.2 Installing/removing the server in/from the rack



CAUTION!

- Please observe the safety information and notes on rack mounting in chapter "[Important information](#)" on page 31.
- At least two people are needed to install / remove the server in the rack. (For the Japanese market, please refer to "安全上の注意およびその他の重要情報".)
- The rack may tip over if more than one unit is pulled out at the same time.
- The server may not occupy the top height units of the rack (38HU/42HU PRIMECENTER Rack, DataCenter Rack, 19-inch standard rack (for the Japanese market)), as otherwise boards cannot be replaced even with the plug-in module fully extended.

4.2.1 Rack system requirements

The rack systems from Fujitsu PRIMECENTER Rack, DataCenter Rack and 19-inch standard rack (for the Japanese market) support the installation of PRIMERGY servers. Installation in most current rack systems from other manufacturers (3rd party racks) is also supported.

To accommodate the ventilation concept and ensure proper ventilation, any unused areas in the rack must be sealed using dummy covers.

The power is supplied via the multiple socket outlets fitted in the rack.

Fujitsu rack systems

The main features of PRIMECENTER Rack, DataCenter Rack and 19-inch standard rack (for the Japanese market) are as follows:

- support systems that can be mounted without tools
- support systems having a linear alignment feature to ensure that they can be adjusted to different rack depths

PRIMECENTER Rack and DataCenter Rack provide an enhanced cable management in the lateral rack area.

Installing/removing the server in/from the rack



For PRIMECENTER Racks and DataCenter Racks:

The mounting of the rails in the different racks is described in the next sections. Installation of the cable management is described in detail in the Technical Manual for the respective rack.



For 19-inch standard rack (for the Japanese market):

For information on mounting of the rails in the 19-inch standard rack (for the Japanese market) please refer to the "Rack mount guide".

3rd party racks

Certain general conditions must be met:

– Installation dimensions (see the dimensions shown in [figure 6 on page 49](#)):

- 1 Front of rack
- 2 Rear of rack
- A Rack depth (comparison PRIMECENTER Rack 940/1000/1100 mm)
- B Rack width (comparison PRIMECENTER rack 700 mm)
- C Clearance for 19" installation level
- C1 Front 19" installation level
- C2 Rear 19" installation level
- D Cable routing area (cable area depth) and ventilation
- E Space for front panel and ventilation
- F Space for right and left support systems
- P PRIMERGY server installation depth
- a1 Front left support upright
- a2 Front right support upright
- b1 Rear left support upright
- b2 Rear right support upright

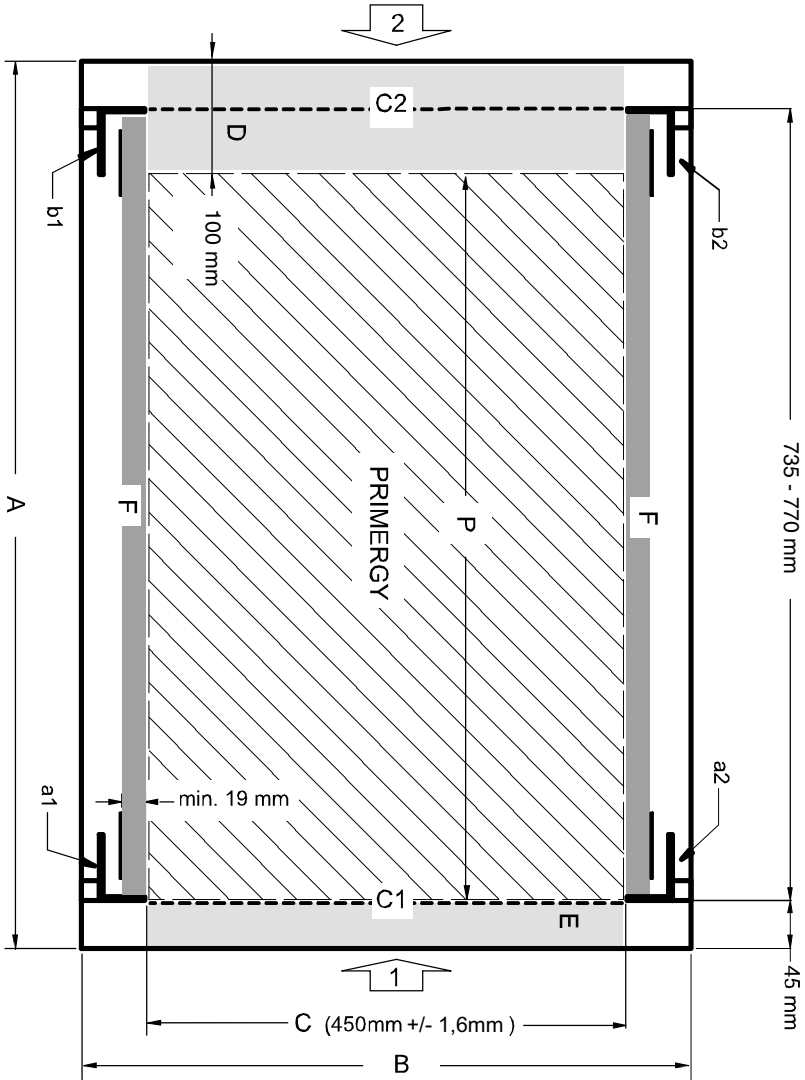

Figure 6: Mechanical requirements

Installing/removing the server in/from the rack

- You must ensure that the safety mechanisms on the server, e.g. stoppers or retaining systems, are functioning correctly.

- The shape of the rack support uprights must ensure that the support systems can be bolted to the front.

The support systems have a linear alignment feature to ensure that they can be adjusted to different rack depths.

- No cable management support (delivered with the mounting kit).

- Climatic conditions:

An unobstructed air intake in the rack front and air discharge in the rear cover of the rack are essential for ventilation of the installed server.

In general, the ventilation concept ensures that the necessary cooling is achieved by the horizontal self-ventilation of the installed devices (air flow from the front to the rear).

- Power supply:

For installation in 3rd party racks, you must ensure that the appropriate socket strips are present.

4.2.2 Installation in PRIMECENTER/DataCenter Rack

For installation in a PRIMECENTER/DataCenter rack, the following parts are required:

- Support bracket
- One support system on the left and one on the right
- M5 centering fixtures (screws with integrated plugwashers)



- The descriptions and figures in this section refer to the current support system. For other support systems you will find the appropriate description in the packaging of the rack mounting kit. For information on mounting of the rails in the 19-inch standard rack (for the Japanese market) please refer to the "Rack mount guide".
- General information regarding server installation in the rack is included in the technical manual for the appropriate rack.
- For information on mounting of the server in the 19-inch standard rack (for the Japanese market) please refer to the Rack mount guide.

Fitting the support bracket

When mounting the left support system in the corresponding rack, the supplied support bracket must first be mounted flush with the underside of the device on the rear left support upright.

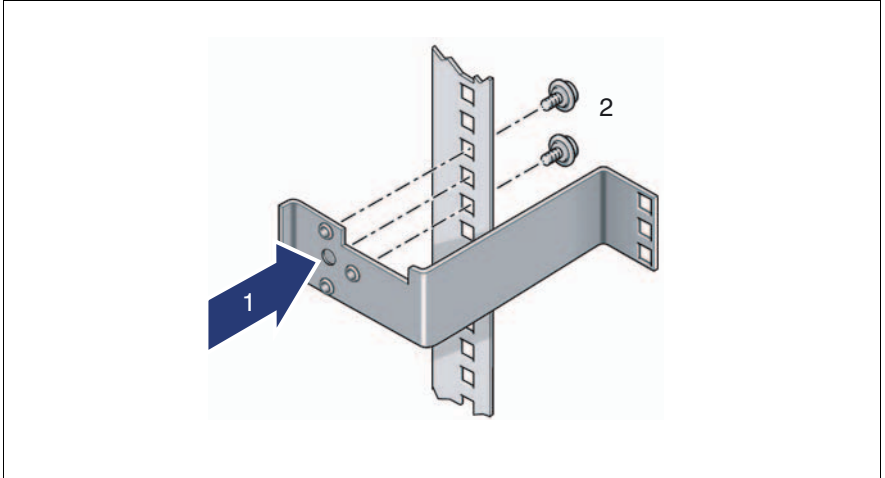

Figure 7: Fitting the support bracket

- Position the support bracket at the corresponding height on the rear left support upright, (place knob in the corresponding hole) (1) and secure it with the two supplied M5 centering fixtures (2).

Removing the outer telescopic rail

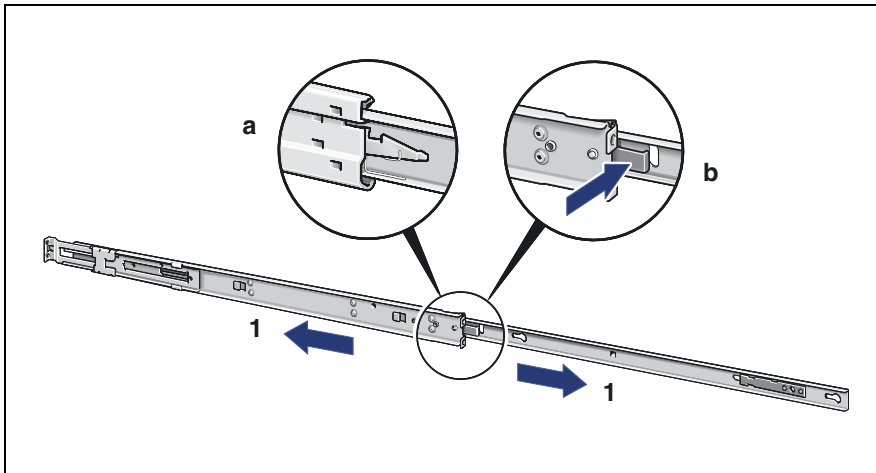

Figure 8: Removing the outer telescopic rail

- ▶ Extend the telescopic rail fully (1).
- ▶ Unlock the outer telescopic rail and remove it.

With fully-extendable rails (a): Press the locking lever to release the server rail.

With partially extendable rails (b): Press the release spring to release the server rail.

- ▶ Repeat the steps with the second telescopic rail.

Installing the support systems

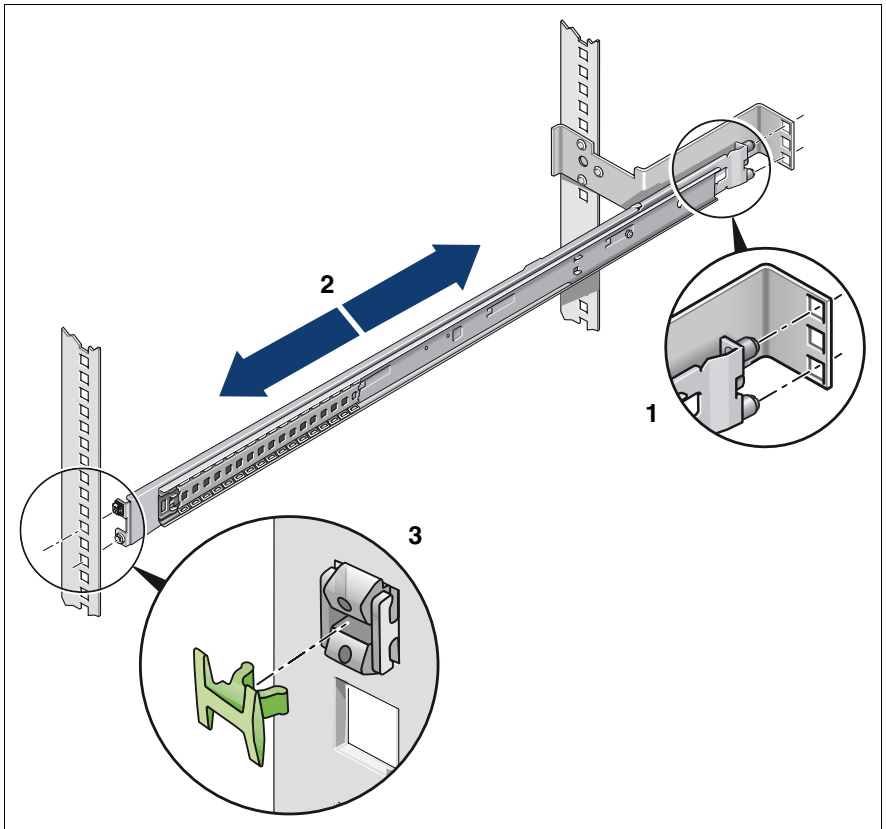

Figure 9: Fit the left support system in the PRIMECENTER/DataCenter rack

- ▶ Position the left support system in the support bracket (insert retaining bolts) - see (1).
- ▶ Clamp the left-hand support system (2) between the front left support upright and the support bracket by pressing the support system together, positioning it on the front support upright and releasing it again. The support system automatically adjusts to the rack depth.



The support system no longer has to be fixed to the front support upright because the easy lock engages and ensures a firm fit.

Installing/removing the server in/from the rack

- ▶ Insert (3) the safety lock into the easy lock (snap fit).



CAUTION!

Ensure that the safety lock has been inserted before the server is inserted!

- ▶ Repeat the above steps for the right-hand support system (with the front and rear right support uprights).
- ▶ Fit the PRIMECENTER/DataCenter rack cable management as described in the technical manual for the corresponding rack.



Figure 10: Position of the cage nuts

- ▶ Fit the cage nuts for securing the server in the corresponding catches on the right and left support uprights.

Preparing the server



For the Japanese market:
Refer to the "Rack Mounting Guide" for more detailed explanation and for other support systems.



Figure 11: Preparing the server

- ▶ Place the outer telescopic rails on the sides of the server (see arrow 1 in [figure 11](#)).
- ▶ Slide the outer telescopic rails forwards to secure them (see arrow 2 in [figure 11](#)).

Inserting the server

i For the Japanese market:
Refer to the "Rack Mounting Guide" for more detailed explanation and for other support systems.

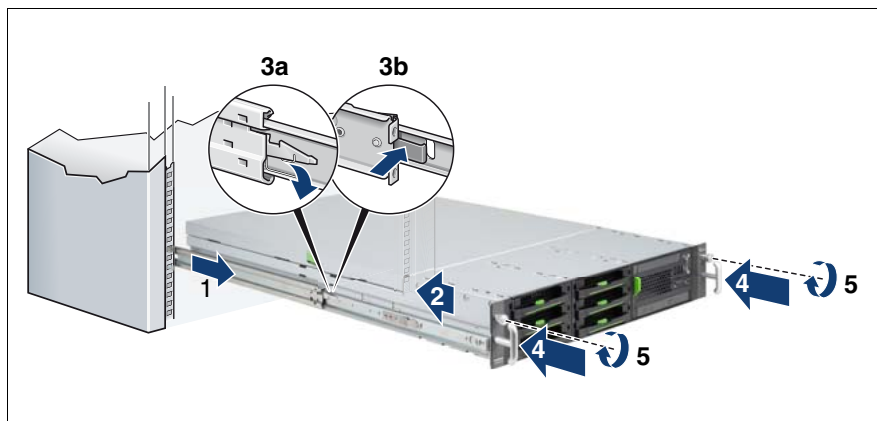

Figure 12: Inserting the server

CAUTION!
Ensure that the safety lock has been inserted **before** the server is inserted (see [figure 9 on page 53](#)).

CAUTION!
At least two people are needed to position the server in the rack.
(For the Japanese market, please refer to "安全上の注意およびその他の重要情報".)

- ▶ Extend the telescopic rails completely to the front (1).

i They must click into place so that they can no longer be moved.

- ▶ Insert the prepared server into the protruding interior telescope rails (2) until the rails engage.
- ▶ Release the locking mechanism of both telescopic rails - see (3a) for fully extending rails and (3b) for partially extending rails.
- ▶ Push the server as far as it will go into the rack (4).
- ▶ Fasten the server to the rack (5) using the two knurled screws (front panel).

- ▶ Route the cables as described in the technical manual for the rack in question with the server pushed in.

4.2.3 Installation in 3rd party racks

 The support systems from Fujitsu are suitable for use in any 3rd party racks for standard servers (installation depth 714 - 785 mm) without restrictions.

- ▶ Refer to the manual from the rack manufacturer for details of the mechanical installation and the climatic conditions.



CAUTION!

When installing in 3rd party racks, it must be ensured that an air flow from the front to the back of the rack is guaranteed.

- ▶ Fit the required original parts (support bracket or cable management system).



Under certain circumstances, you will not be able to use some of the parts from the rack installation kit supplied - you will need to use original 3rd party rack parts instead.

Racks with installation depth of 735 mm

The lengths of the telescopic rails do not need to be adjusted with respect to each other for the installation in rack systems with 735 mm installation depth.

- ▶ Secure the support systems as described in section "[Installing the support systems](#)" on page 53.
- ▶ Mount the server (see "[Inserting the server](#)" on page 56) and route the cables as described in the original manual of the rack.



CAUTION!

Ensure that the safety lock has been inserted **before** the server is inserted (see [figure 9 on page 53](#)).

Racks with installation depth smaller/greater than 735 mm

The support systems can be used for installation depths of 714 - 785 mm. The spring element of the support system is used to adjust the length as required.

- ▶ Secure the support systems as described in "[Installing the support systems](#)" on page 53.
- ▶ Mount the server (see "[Inserting the server](#)" on page 56) and route the cables as described in the original manual of the rack.



CAUTION!

Ensure that the safety lock has been inserted **before** the server is inserted (see [figure 9 on page 53](#)).

4.2.4 Installation in a telecommunication rack with 48 V DC power



The support systems from Fujitsu are suitable for use in any 3rd party racks for standard servers (installation depth 714 - 785 mm) without restrictions.

- ▶ Refer to the manual from the rack manufacturer for details of the mechanical installation and the climatic conditions.



CAUTION!

When installing in 3rd party racks, it must be ensured that an air flow from the front to the back of the rack is guaranteed.

- ▶ Fit the required original parts (support bracket or cable management system).



Under certain circumstances, you will not be able to use some of the parts from the rack installation kit supplied - you will need to use original 3rd party rack parts instead.

- ▶ Refer to the manual from the rack manufacturer for details of the electrical installation. The wires of the power cable must be connected to the dc power as described in the manufacturers manual.

4.3 Connecting devices to the server

The connectors for external devices are on the front and rear of the server. The additional connectors available on your server depend on the expansion cards installed. For further information refer to the "Options Guide".

RX300 S6

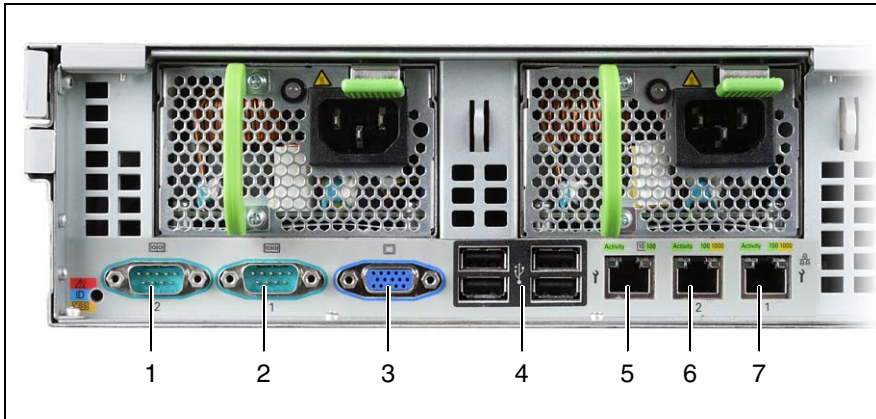

Figure 13: Connection panel on the rear

1	Serial connector COM2 (turquoise)	5	Service LAN connector
2	Serial connector COM1* (turquoise)	6	System LAN connector (LAN 2)
3	Video connector (blue)	7	Shared LAN connector (LAN 1)
4	USB connectors (black)		

RX300 S6 CG

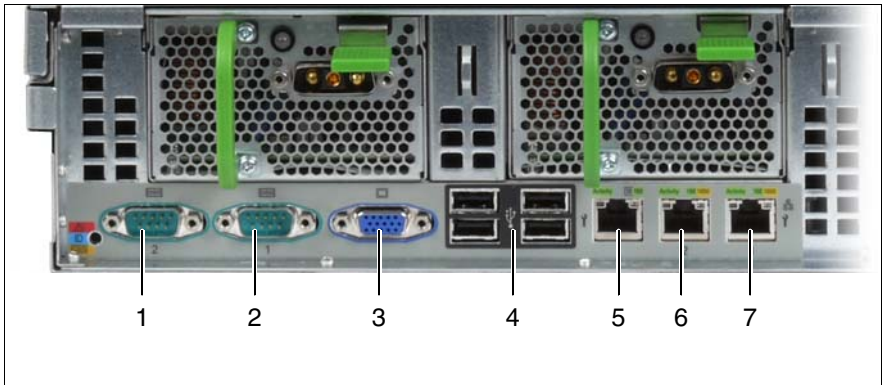

Figure 14: Connection panel on the rear CG variant

1	Serial connector COM2 (turquoise)	5	Service LAN connector
2	Serial connector COM1* (turquoise)	6	System LAN connector (LAN 2)
3	Video connector (blue)	7	Shared LAN connector (LAN 1)
4	USB connectors (black)		

* The serial interface COM1 can be used as the standard interface or for communication with iRMC S2.

i Some of the devices that can be connected may require the installation and setting up of special software (e.g. drivers) (see the documentation for the connected device).

► Connect the desired devices to the server.

Connecting devices to the server

Three additional USB connectors (1) are located on the front of the server (figure 15):

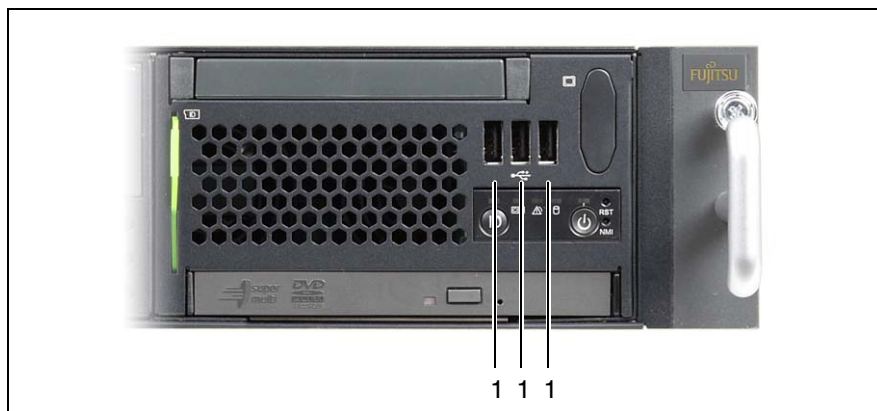

Figure 15: Front side: additional USB connectors

i If components with large power requirements (e.g. external USB hard disk drives) are connected simultaneously, these USB connectors may be switched off.

Connecting the keyboard, mouse and monitor

► Connect the monitor, keyboard and mouse to the standard connectors of the server (see table and figure 13 on page 60).

i If a separate graphics card is installed in a slot, the graphic controller on the system board is automatically deactivated. The corresponding video connector (VGA) can not be used. Plug the data cable of the monitor into the video connector of the graphics card.

► Connect the power cable of the monitor to the mains socket strip of the rack.



CAUTION!

The rated current for the monitor is indicated on the technical data label on the monitor or in the operating manual for the monitor.

4.4 Connecting the server to the power source

In its basic configuration level the server has a hot-plug power supply unit.

A second hot-plug power supply unit can be added to ensure a redundant power supply. If one power supply unit is defective, the other then guarantees unimpaired operation. Each hot-plug power supply unit can be replaced during operation (see ["Hot-plug power supply units" on page 96](#)).



CAUTION!

The server is automatically set to a mains voltage in the range 100 V - 240 V. You may only operate the server if its rated voltage range corresponds to the local mains voltage.

For the RX300 S6 CG variant the server is automatically set to a mains voltage in the range 40.5 V - 57 V. You may only operate the server if its rated voltage range corresponds to the local mains voltage.

4.4.1 RX300 S6 to the mains

4.4.1.1 Connecting the power cord

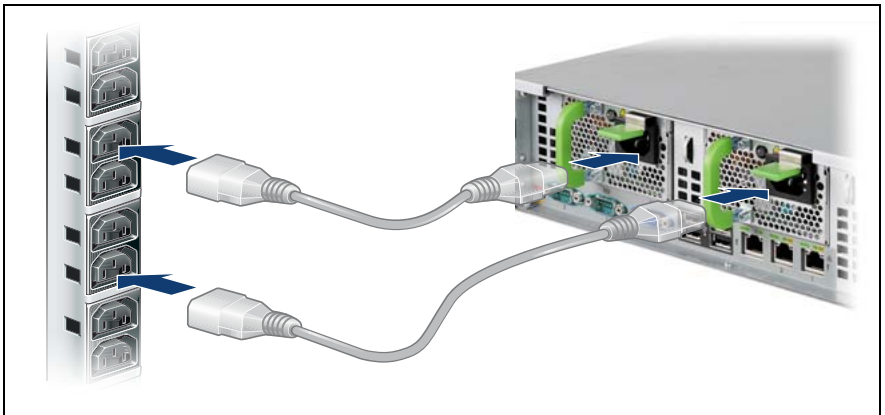

Figure 16: Connecting the server to the mains

- ▶ Connect the power cable with the insulated connector to the power supply unit of the server, and plug the power plug into a grounded outlet on the mains socket strip on the rack (see Technical Manual of the rack).

Connecting the server to the power source

i A phase redundancy in the power supply of the server can be set up if two hot-plug power supply units are installed.

In this case, each of the power supply units is either connected to two different phases or to two separate circuits of the internal power supply network.

4.4.1.2 Using cable ties

You can secure the power cable using a cable tie to ensure that the insulated connector cannot be disconnected from the server accidentally. The cable tie is included in the accessories pack that is delivered together with the server.

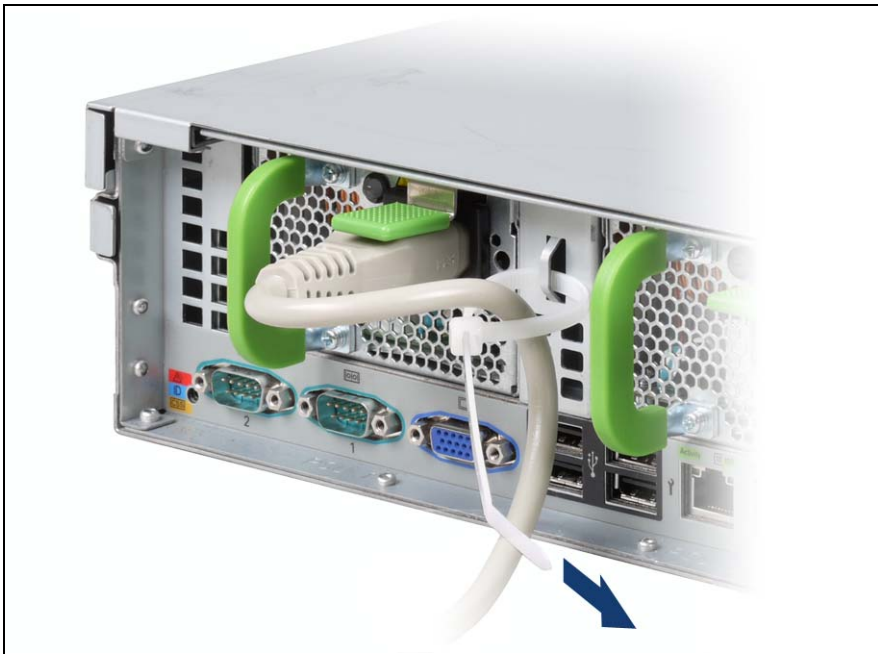

Figure 17: Using cable ties

- ▶ Thread the cable tie through the eye.
- ▶ Pull the cable tie tight to secure the power cable.

The insulated connector cannot now be disconnected from the server accidentally.

i You can loosen the cable tie by opening the small lock.

4.4.2 RX300 S6 CG to the direct current

4.4.2.1 Connecting the power cord

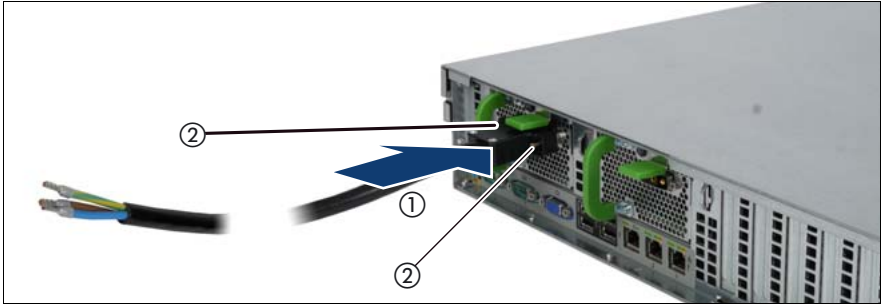

Figure 18: Connecting the server to the dc voltage

- ▶ Connect the power cable with connector to the power supply unit of the server (1).
- ▶ Attach the connector with the 2 screws (2)
- ▶ Connect the wire labeled "Ground" to an appropriate earth ground.
- ▶ Connect the other two wires of the power cable to the current bar on the rack (see Technical Manual of the rack).

4.5 Notes on connecting/disconnecting cables



CAUTION!

Always read the documentation supplied with the device you wish to connect.

Never connect, or disconnect cables during a thunderstorm.

Never pull on a cable when disconnecting it. Always take hold of the cable by the plug.

Follow the sequence described below to connect or disconnect external devices to or from the server:

Be sure to wait for 10 seconds or more after shutdown before turning the server on.

Connecting cables

- ▶ Turn off all power and equipment switches.
- ▶ Disconnect all power plugs from the properly grounded power outlets.
- ▶ Connect all cables to the server and peripherals.
- ▶ Plug all data communication cables into the utility sockets.
- ▶ Plug all power cords into the properly grounded power outlets.

Disconnecting cables

- ▶ Turn off all power and equipment switches.
- ▶ Disconnect all power plugs from the properly grounded power outlets.
- ▶ Unplug all data communication cables from the utility sockets.
- ▶ Disconnect the relevant cables from the server and all the peripherals.



For connecting or disconnecting LAN cables, the server need not to be powered off. To avoid loss of data teaming function has to be enabled.

5 Starting up and operation



CAUTION!

Please note the safety instructions in [chapter "Important information" on page 31](#)

5.1 Controls and indicators

5.1.1 Front of server

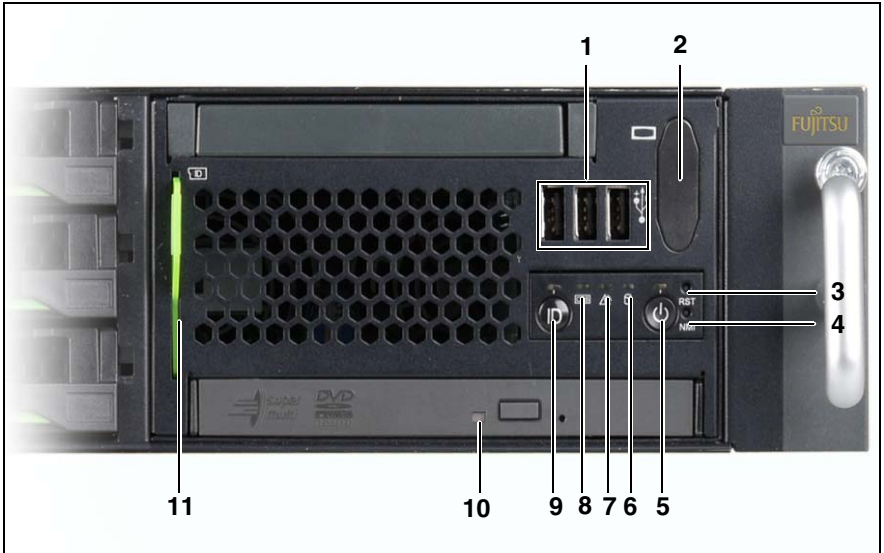

Figure 19: Front side: indicators and controls

1	3 x USB connectors	7	Global Error indicator
2	Video connector (VGA) (option)	8	CSS indicator
3	Reset button	9	ID indicator / ID button
4	NMI button	10	DVD drive activity indicator
5	Power-on indicator / On/Off button	11	ID Card
6	Hard disk activity indicator		

5.1.1.1 Control elements



On/Off button

When the system is switched off, it can be switched on again by pressing the On/Off button.

When the system is operating, pressing the On/Off button will switch off the system.



The On/Off button does not disconnect the server from the mains voltage. To disconnect from the mains completely, remove the power plug(s).

NMI

NMI button



CAUTION!

Do not press! Risk of loss of data! The NMI button may only be used by service.

RST

Reset button

Pressing the reset button reboots the system.



CAUTION!

Risk of loss of data!

ID

ID button

Lights up (blue) on the front and on the rear of the server when the ID button is pressed. Both ID indicators are synchronized.

5.1.1.2 Indicators on the control panel



Power-on indicator (two colors)

Lights up green when the server is switched ON.

Lights up orange when the server is switched OFF, but mains voltage is present (standby mode).



Hard disk activity indicator (green)

Lights up green when an internal drive (HDD or backup drive) is being accessed.



Global Error indicator (orange)

- **Lights up orange** if a prefailure event has been detected that requires (precautionary) service intervention.
- **Flashes orange** if an error was detected that requires service intervention.
- **Does not light up** if there is no critical event.

If the event is still acute after a power failure, the indicator is activated after the restart.

The indicator also lights up in standby mode.

You can find more details on the indicated errors in the System Event Log (SEL), on the ServerView Local Service Panel, on the ServerView Local Service Display, in the ServerView Operations Manager or via the iRMC S2's Web interface.

CSS CSS indicator (yellow)

- **Lights up yellow** if a prefailure event was detected for a CSS component that you can fix yourself (for reasons of precaution) with the CSS concept.
- **Flashes yellow** if an error was detected that you can fix yourself with the CSS concept.
- **Does not light up** when the system is OK.

If the event is still acute after a power failure, the indicator is activated after the restart.

The indicator also lights up in standby mode.

For more information on the CSS concept, see "[Customer Self Service \(CSS\)](#)" on page 14.

ID ID indicator (blue)

Lights up blue when the system has been selected by pressing the ID button. To deactivate, press the button again.

The ID indicator can also be activated via the ServerView Operations Manager and the iRMC S2 Web interface and its status reported to the ServerView Operations Manager and the iRMC S2.

5.1.1.3 Indicators on the drives

DVD drive activity indicator

Lights up green when the storage medium is being accessed.

Hard disk drive indicators



Figure 20: Indicators on the 3.5 inch and 2.5 inch HDD modules

1	LED green	HDD BUSY <ul style="list-style-type: none"> – Lights up: HDD in active phase – Does not light: HDD inactive (drive inactive)
2	LED orange	HDD FAULT (orange) (in conjunction with a RAID controller) <ul style="list-style-type: none"> – Does not light: no HDD error – Lights up: HDD Faulty or Rebuild Stopped (drive defective/needs replacing, a rebuild process was stopped or the HDD module is not correctly inserted) – Slow flashing: HDD Rebuild (the data is being restored after changing a drive) – Fast flashing: HDD Identify

Solid state disk indicators



Figure 21: Indicators on the SSD modules

1	LED green	BUSY <ul style="list-style-type: none">– Lights up: SSD in active phase– Does not light: SSD inactive (drive inactive)
2	LED orange	FAULT (orange) (in conjunction with a RAID controller) <ul style="list-style-type: none">– Does not light: no error– Lights up: Faulty or Rebuild Stopped (drive defective/needs replacing, a rebuild process was stopped or the module is not correctly inserted)– Slow flashing: Rebuild (the data is being restored after changing a drive)– Fast flashing: Identify

5.1.2 Rear of server

CSS, Global Error and ID indicators



Figure 22: Indicators on the connection panel: Global Error/CSS/ID indicator

1	Global Error/CSS/ID indicator (orange, yellow and blue)
---	---



Global Error indicator (orange)

- **Lights up orange** if a prefailure event has been detected that requires (precautionary) service intervention.
- **Flashes orange** if an error was detected that requires service intervention.
- **Does not light up** if there is no critical event.

If the event is still acute after a power failure, the indicator is activated after the restart.

The indicator also lights up in standby mode.

You can find more details on the indicated errors in the System Event Log (SEL), on the ServerView Local Service Panel, on the ServerView Local Service Display, in the ServerView Operations Manager or via the iRMC S2's Web interface.

CSS CSS indicator (yellow)

- **Lights up yellow** if a prefailure event was detected for a CSS component that you can fix yourself (for reasons of precaution) with the CSS concept.
- **Flashes yellow** if an error was detected that you can fix yourself with the CSS concept.
- **Does not light up** when the system is OK.

If the event is still acute after a power failure, the indicator is activated after the restart.

The indicator also lights up in standby mode.

For more information on the CSS concept, see "[Customer Self Service \(CSS\)](#)" on page 14.

ID ID indicator (blue)

Lights up blue when the system has been selected by pressing the ID button. To deactivate, press the button again.

The ID indicator can also be activated via the ServerView Operations Manager and the iRMC S2 Web interface and its status reported to the ServerView Operations Manager and the iRMC S2.

LAN indicators



Figure 23: Indicators on the connection panel: LAN indicators

1	LAN link/transfer (service LAN)	<p>Steady green signal when a LAN connection exists.</p> <p>Remains dark when no LAN connection exists.</p> <p>Flashes green when LAN transfer takes place.</p>
2	LAN speed (service LAN)	<p>Steady green signal in the event of a LAN transfer rate of 100 Mbit/s.</p> <p>Remains dark in the event of a LAN transfer rate of 10 Mbit/s.</p>
3	LAN link/transfer (system LAN)	<p>Steady green signal when a LAN connection exists.</p> <p>Remains dark when no LAN connection exists.</p> <p>Flashes green when LAN transfer takes place.</p>
4	LAN speed (system LAN)	<p>Steady yellow signal in the event of a LAN transfer rate of 1 Gbit/s</p> <p>Steady green signal in the event of a LAN transfer rate of 100 Mbit/s.</p> <p>Remains dark in the event of a LAN transfer rate of 10 Mbit/s.</p>

i Depending on the settings in the BIOS, the standard LAN connector 1 may also be used as a service LAN connector. You will find further information in the "D2619-N15 BIOS Setup Utility for PRIMERGY RX300 S6 and TX300 S6" manual.

Indicators on the hot-plug power supply unit 100 V - 240 V

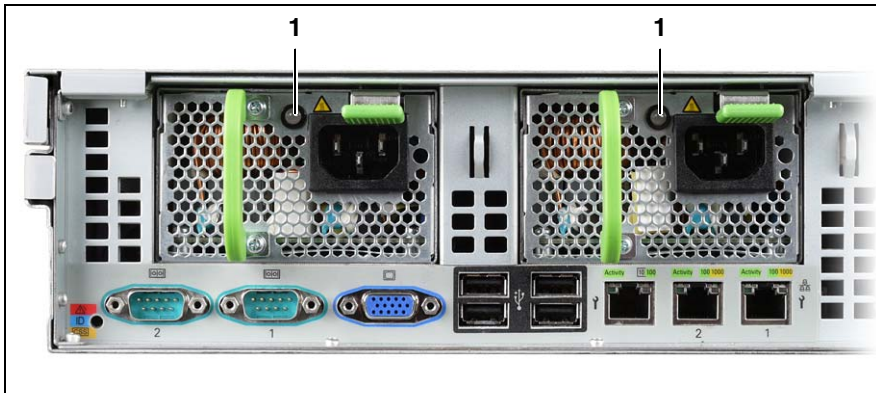

Figure 24: Indicator on hot-plug power supply unit

1	<p>Indicator on hot-plug power supply unit (two colors)</p> <p>Flashes green when the server is switched off, but mains voltage is present (standby mode).</p> <p>Lights up green when the server is switched on and functioning properly.</p> <p>Lights up orange if the power supply unit has failed.</p>
---	---

Indicators on the hot-plug power supply unit 40.5 V - 57 V

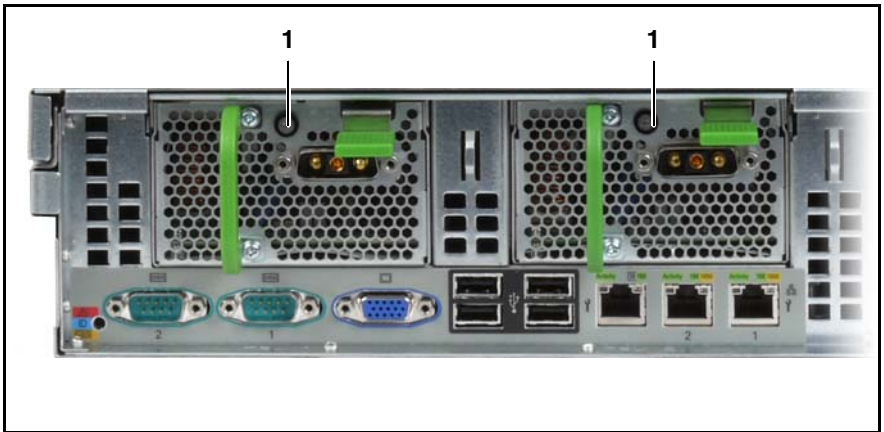

Figure 25: Indicator on hot-plug power supply unit

1	<p>Indicator on hot-plug power supply unit (two colors)</p> <p>Flashes green when the server is switched off, but primary DC voltage is present (standby mode).</p> <p>Lights up green when the server is switched on and functioning properly.</p> <p>Lights up orange if the power supply unit has failed.</p>
---	--

5.1.3 Indicators of the hot-plug fans

A status indicator (LED on the system board) is assigned to each fan. The status indicators are not visible unless the housing is open. The respective LED is set with commands in Server Management.

LED (orange)	Meaning
does not light up	Fan in operation
flashing	Fan failure
lights up	Fan prefailure

5.2 Switching the server on and off



CAUTION!

- It nothing appears on the screen but flickering stripes after switching on the server, switch the server off immediately (see chapter "[Troubleshooting and tips](#)" on page 89).
- The On/Off button does not disconnect the server from the mains voltage. To completely disconnect it from the mains voltage, remove the power plug(s) from the socket(s).
- Do not move, strike, or shake the server when it is turned on. This can damage the hard disk in the server and cause data loss.
- Turn the server on when the temperature is in its operating environment range (10–35°C). For details on the operating environment, refer to "Safety Precautions". When operating the device outside of this operating environment, the server may operate improperly, damage data etc. Furthermore, Fujitsu cannot be held responsible for any related damage, malfunction, or loss of data, etc.
- Be sure to wait for 10 seconds or more after shutdown before turning the server on.
- After connecting the power cable, press the On/Off button after it passes for more than 10 seconds.

Switching the server on

The Power-on indicator (item 5 in figure [19 on page 67](#)) lights up orange (standby mode) when the server is connected to the mains.

– Starting up for the first time:

For the Japanese market, please refer to "はじめにお読みください".

- ▶ Press the On/Off button (item 5 in figure [19 on page 67](#)).
- ▶ Insert ServerView Suite DVD 1 in the DVD drive.
- ▶ Follow the on-screen instructions (see also section "[Configuring the server and installing the operating system with the ServerView Installation Manager](#)" on page 83 or section "[Configuring the server and installing the operating system without the ServerView Installation Manager](#)" on page 84).

Switching the server on and off

– System already installed:

- ▶ Press the On/Off button (item 5 in figure [19 on page 67](#)).

The server is switched on, performs a system test and boots the operating system.



In the case of configurations with a large memory size, the boot process may be prolonged and the screen may remain dark for about 20 seconds.

Switching the server off

The Power-on indicator (item 5 in figure [19 on page 67](#)) lights up green.

- ▶ Shut down the operating system properly.

The server is switched off automatically and goes into standby mode. The power-on indicator lights up orange.



If the operating system does not switch the server off automatically, press the On/Off button for at least four seconds and/or send a corresponding control signal for power button override.

Other On/Off options

Besides the On/Off button, the server can be switched ON and OFF in the following ways:

– Timer-controlled switch-on/off

Using the ServerView Operations Manager or iRMC S2, you can configure that the server is switched on/off controlled by timer.

– Ring indicator

The server is switched on by an internal or external modem.

– Wake up On LAN (WOL)

The server is switched on by a command via the LAN (Magic Packet™).

– After power failure

The server automatically reboots following a power failure (depending on the settings in the BIOS or in iRMC S2).

– Power button override

The system can be switched off (hard power off) by holding down the On/Off button (approximately 4 - 5 seconds).



CAUTION!

There is a risk that data may be lost.

– iRMC S2

iRMC S2 offers various options for switching the server on and off, e.g. via the *Power On Off* page of the iRMC S2 Web interface.



CAUTION when turning the power off (Windows Server 2008 or Windows Server 2003)!

The operation of the power switch can be specified as "Do Nothing", "Ask me what to do" (only for Windows Server 2003), "Stand by", "Hibernate", and "Shutdown" depending on the OS settings. The default is "Shutdown".

On this server, functions corresponding to "Stand by" and "Hibernate" are supported as BIOS and hardware functions. However, some drivers and software installed in the server do not support these functions. For this reason, functions corresponding to "Stand by" and "Hibernate" are unavailable on this server. When the operating mode is set to "Stand by" or "Hibernate", the system may operate improperly or hard disk data may be corrupted.

For details about operating mode settings, refer to the manual supplied with the OS.

5.3 Configuring the server

This section contains information about configuring the server and installing the operating system.

5.3.1 Configuring the SAS/SATA RAID controller

The server has a SAS/SATA RAID controller with "Integrated Mirroring Enhanced" functionality or "MegaRAID functionality". You can configure the SAS/SATA RAID controller either before or during installation with the ServerView Installation Manager. Using the ServerView Installation Manager is recommended.



The controller makes a separate utility available for IME configuration. For further information, refer to the "Integrated RAID for SAS User's Guide" (on the ServerView Suite DVD 2 under *Industry Standard Servers - Expansion Cards - Storage Adapters - LSI RAID / SCSI Controllers*).

A separate utility is available to the controller for MegaRAID configuration. For further information, refer to the "SAS Software User's Guide" (on the ServerView Suite DVD 2 under *Industry Standard Servers - Expansion Cards - Storage Adapters - LSI Configuration Software*).

Further information on modular RAID controllers is provided in the "Modular RAID Controller Installation Guide" (on the ServerView Suite DVD 2 under *Industry Standard Servers - Expansion Cards - Storage Adapters - LSI RAID / SCSI Controllers*).



Descriptions of operating systems not covered in the controller manual are provided in the corresponding readme files on the driver CDs.

5.3.2 Configuring the server and installing the operating system with the ServerView Installation Manager

Using the ServerView Installation Manager on the ServerView Suite DVD 1 provided, you can conveniently configure the server and install the operating system. This includes configuring the server-specific settings using the ServerView Configuration Manager and configuring the RAID controller using the **ServerView RAID Manager**.

Advantages of the ServerView Installation Manager

- Wizard assisted configuration of your server hardware and disk arrays
- Wizard assisted installation of all leading server operating systems
- Wizard-assisted creation of configuration files for unattended installation of several PRIMERGY servers with identical hardware configurations.
- Installation of drivers and additional software.



The software that can be installed depends on your server's hardware configuration. This configuration is detected automatically.



Descriptions of operating systems not covered in the RAID controller manual are provided in the corresponding readme files on the driver CDs.

To find out how to operate the ServerView Installation Manager and for further information, refer to the associated manual.

If you are using the ServerView Installation Manager, you can skip the following section on how to configure the server and install the operating system. Continue from section ["Cleaning the server" on page 85](#).

5.3.3 Configuring the server and installing the operating system without the ServerView Installation Manager

Configuring SAS/SATA RAID controller with "Integrated Mirroring Enhanced"

Configure the controller as described in section ["Configuring the SAS/SATA RAID controller" on page 82](#).

Configuring SAS/SATA RAID controller with "MegaRAID functionality"

Configure the controller as described in section ["Configuring the SAS/SATA RAID controller" on page 82](#).

Installing the operating system

- ▶ Insert the CD/DVD for the operating system you want to install.
- ▶ Reboot the server.
- ▶ Follow the instructions on screen and in the manual for the operating system.

5.4 Cleaning the server



CAUTION!

Switch the server off and disconnect the power plugs from the properly grounded power outlets.

Do not clean any interior parts yourself; leave this job to a service technician.

Do not use any cleaning agents that contain abrasives or may corrode plastic.

Ensure that no liquid enters the system. Ensure that the ventilation areas of the server and the monitor are clear.

Do not use any cleaning sprays (including flammable types). It may cause a device failure or a fire.

Clean the keyboard and the mouse with a disinfecting cloth.

Wipe the server and monitor casing with a dry cloth. If particularly dirty, use a cloth that has been moistened in a mild domestic detergent and then carefully wrung out.

6 Property and data protection

The rack model is protected against unauthorized access by a lockable rack door.

To protect your system and data internally against unauthorized access, you can use the BIOS Setup security functions.

6.1 BIOS Setup security functions

The *Security* menu in BIOS Setup offers various options for protecting your data from unauthorized access. By combining these options, you can also achieve optimum protection for your system.



A detailed description of the *Security* menu and how to assign passwords can be found in the BIOS Setup documentation on the ServerView Suite DVD 2.

7 Troubleshooting and tips



CAUTION!

Follow the safety instructions in the "Safety notes and regulations" manual or "安全上のご注意" and in chapter ["Important information" on page 31](#).

If a fault occurs, attempt to resolve it using the measures described:

- in this chapter,
- in the documentation for the connected devices,
- in the help systems of the software used.

If you fail to correct the problem, proceed as follows:

- ▶ Make a list of the steps performed and the circumstances that led to the fault. Also make a list of any error messages that were displayed.
- ▶ Switch off the server.
- ▶ Contact our customer service team.

7.1 Power-on indicator remains unlit

The power-on indicator remains dark after you switch on your device.

Power cable incorrectly connected

- ▶ Make sure that the power cable(s) is/are correctly connected to the server and the grounded power outlet(s).

Power supply overloaded

- ▶ Disconnect the server power plug(s) from the grounded power outlet(s).
- ▶ Wait a few seconds before you plug it/them into the grounded power outlet(s) again.
- ▶ Switch on your server.

7.2 Server switches itself off

Server Management has detected an error

- ▶ Check the error list of System Event Log in ServerView Operations Manager or in the iRMC S2 web interface, and attempt to eliminate the error.

7.3 Screen remains blank

Monitor is switched off

- ▶ Switch on your monitor.

Screen has gone blank

- ▶ Press any key on the keyboard.
or
- ▶ Deactivate screen saver. Enter the appropriate password.

Brightness control is set to dark

- ▶ Set the brightness control on the monitor to light. For detailed information, refer to the operating manual supplied with your monitor.

Power cable or monitor cable not connected

- ▶ Switch off the monitor and the server.
- ▶ Check whether the power cable is properly connected to the monitor and to the grounded power outlet.
- ▶ Check whether the monitor cable is properly connected to the server and monitor (if it is plugged in with a connector). If a separate graphics card is installed in the server, then the monitor cable must be connected to the graphics card.
- ▶ Switch on the monitor and the server.

7.4 Flickering stripes on monitor screen



CAUTION!

Switch off the server immediately. Risk of damaging the server.

Monitor does not support the set horizontal frequency

- ▶ Find out which horizontal frequency your monitor screen supports. You will find the horizontal frequency (also known as line frequency or horizontal deflection frequency) in the documentation for your monitor.
- ▶ Refer to the documentation for your operating system or the software for the screen controller for details of how to set the correct horizontal frequency for your monitor, and follow the procedure accordingly.

7.5 No screen display or display drifts

The wrong horizontal frequency or resolution has been selected for the monitor or for the application program.

- ▶ Find out which horizontal frequency your monitor screen supports. You will find the horizontal frequency (also known as line frequency or horizontal deflection frequency) in the documentation for your monitor.
- ▶ Refer to the documentation for your operating system or the software for the screen controller for details of how to set the correct horizontal frequency for your monitor, and follow the procedure accordingly.

7.6 Incorrect date and time

- ▶ Set the date and time in the operating system or in the BIOS Setup under the *Main* menu, using *System Date* and *System Time* respectively.



Note that the operating system may affect the system time. For example, the operating system time may deviate from the system time under Linux, and would overwrite the system time in the default setting on shutdown.

If the date and time are still wrong after the server has been switched off and back on again, replace the lithium battery (for a description refer to the Technical Manual for the D2619-N15 system board) or contact our customer service team.

7.7 System will not boot

The system will not boot after installing a new hard disk drive.

SAS configuration incorrect

- ▶ Check the settings for the hard disk drives (*SAS Device Configuration*) and the additional settings in the SAS configuration menu.

7.8 Drives reported as "dead" when starting system

This error message may occur when the drives are operated with a RAID controller.

RAID controller configuration incorrect

- ▶ Check and correct the settings for the drives using the RAID controller utility.

Further information is provided in the manual for the RAID controller.

7.9 Added drive reported as defective

RAID controller is not configured for this drive

The drive was probably installed when the system was switched off.

- ▶ Reconfigure the RAID controller for the drive using the corresponding utility. Information is provided in the documentation for the RAID controller.

or

- ▶ Remove and reinstall the drive while the system is switched ON.

If the hard disk drive continues to be shown as defective, then replace it (see ["Hot-plug disk drives" on page 100](#)).

7.10 Error message on screen

The meaning of the error message is explained in the documentation for the relevant components and programs on the ServerView Suite DVD 2.

7.11 Expansion cards or onboard devices not recognized

When an expansion card is added, other expansion cards or onboard devices might not be recognized.

- ▶ Reinstall the drivers for the expansion cards or onboard devices that are not recognized.

7.12 Temperature warning

A temperature warning is output to the hardware event log and OS event log, or ServerView issues a notification of a temperature warning such as by a popup message

No effect of keyboard or mouse

The above log is output or the above notification is issued by ServerView when the ambient temperature is within 30 to 35°C, which is near the upper limit of the temperature boundaries (10 to 35°C). This is to notify the administrator before the ambient temperature actually exceeds the range of the temperature boundaries.

- ▶ Although continued use within the temperature boundaries poses no problems within itself, reconsider the surrounding environment conditions if this log is output or if ServerView issues this notification.

7.13 No effect of keyboard or mouse

Typing the keyboard does not display any characters, or the mouse cursor does not move.

- ▶ Check to see whether the keyboard and mouse are connected properly. If they are not connected or you replaced them yourself, then connect the cables to the server.

7.14 Optical drive cannot read data

- ▶ Check to see whether the CD/DVD/BD is inserted properly. If the CD/DVD/BD is not inserted, correctly insert the disk so that the label is facing up.
- ▶ Check to see whether the CD/DVD/BD is not dirty. If the CD/DVD/BD is dirty, wipe it in a radial way with a soft, dry cloth.
- ▶ Check to see whether the CD/DVD/BD is not scratched or bent. If scratched or damaged, replace the CD/DVD/BD.

8 CSS components

This chapter describes how to handle CSS components and how to identify defective CSS components and replace them yourself.



Further information on the CSS concept is provided in the "ServerView Suite Local Service Concept - LSC" manual on the ServerView Suite DVD 2.

For the latest information on optional products provided for the RX300 S6 see the configurator of the server:

http://ts.fujitsu.com/products/standard_servers/index.html
(for the EMEA market)

<http://primeserver.fujitsu.com/primergy/system.html>
(for the Japanese market)



CAUTION!

- Do not disassemble the power supply unit. Doing so may cause electric shock.
- Do not damage or modify internal cables or devices. Doing so may cause a device failure, fire, or electric shock.
- Devices inside the server remain hot after shutdown. Wait for a while after shutdown before installing or removing internal options.
- The circuit boards and soldered parts of internal options are exposed and can be damaged by static electricity. Before handling them, first touch a metal part of the server to discharge static electricity from your body.
- Do not touch the circuitry on boards or soldered parts. Hold the metallic areas or the edges of the circuit boards.
- If devices are installed or disassembled using methods other than those outlined in this chapter, the warranty will be invalidated.
- The installation indicated on this note is sometimes changed to the kind of possible options without notice.
- Follow the safety instructions in the chapter "[Important information](#)" on page 31.

Hot-plug components

In the PRIMERGY RX300 S6 server, the following components are considered to be CSS components:

- Hot-plug components
 - Hot-plug power supply units
 - Hot-plug hard disk drives
 - Hot-plug fan modules

You can expand or replace the hot-plug components during operation.

- Non-hot-plug components
 - Memory modules
 - Expansion cards

These components can be changed by you in the event of an error. To do so, first switch off the server and disconnect it from the network before proceeding.

Expansions and upgrades may only be carried out by authorized specialist personnel. These operations are described in the "Options Guide".

8.1 Hot-plug components

This section describes how to handle hot-plug components and how to modify your server hardware (e.g. adding/replacing hot-plug power supply units or hot-plug disk drive modules).

The hot-plug procedure increases the availability of system operation and guarantees a high degree of data integrity and failsafe performance.

8.1.1 Hot-plug power supply units

i A redundant power supply can be created by installing a second hot-pluggable power supply unit (optional). If one power supply unit fails, the other unit ensures operation can continue uninterrupted. The defective power supply unit can be replaced without interrupting operation.

i In the RX300 S6 CG -Variant are one or two hot-pluggable 48 V DC power supply units installed.



CAUTION!

- Areas around the power supply unit may remain extremely hot after shutdown. Wait for a while after shutdown before removing the power supply unit.
- When installing the power supply unit, be sure to confirm that the connector of the PSU is not damaged or bent.
- Do not insert your hands in the power supply unit slot when removing the power supply unit. Doing so may cause electric shock.
- If the power supply unit is hard to remove, do not pull out it by force. Slide the power supply unit all the way down once, and then remove it while holding the lever completely down.
- The power supply unit is heavy, so handle it carefully. If you drop it by mistake, injuries may result.

8.1.1.1 Removing dummy module

The slot for the second hot-plug power supply unit contains a dummy module. This dummy module must be removed before installing a second power supply unit.

- ▶ Remove the dummy module from the second power supply unit slot.



CAUTION!

Keep the dummy module for future use. If the power supply unit is removed and not replaced with a new unit, the dummy module must be reinstalled due to cooling, to comply with applicable EMC regulations (regulations on electromagnetic compatibility) and to protect against fire.

8.1.1.2 Adding a hot-plug power supply unit

- ▶ Slide the second power supply unit into the empty slot until it locks into place (see [section "Replacing the hot-plug power supply unit"](#)) and connect it up (see ["Connecting the server to the power source" on page 63](#)).

8.1.1.3 Replacing the hot-plug power supply unit



CAUTION!

Before replacing a **non defective** power supply unit in a non-redundant configuration (only one power supply unit present) the server must be switched OFF.

- ▶ Remove the cable from the installed power supply unit.

100 - 240 AC power supply

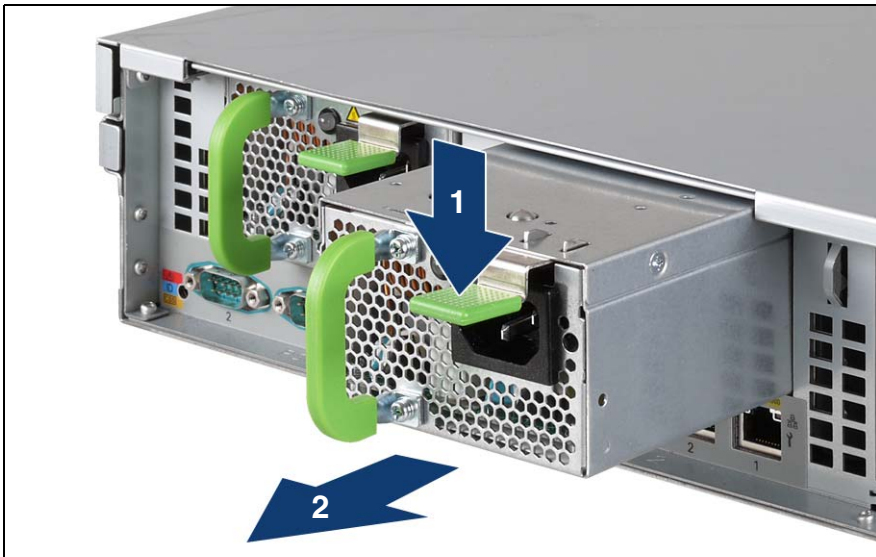

Figure 26: Unlocking and removing the power supply unit

40.5 - 57 DC power supply

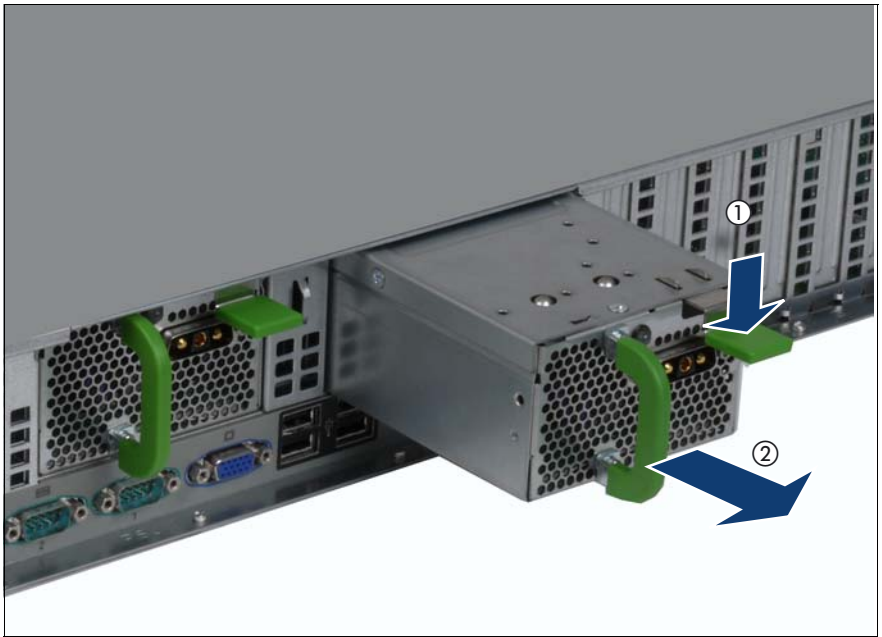

Figure 27: Unlocking and removing the power supply unit

- ▶ Push the green catch in the direction of the arrow (1) while pulling the power supply unit out of its mounting location (2) by the handle.

i Grip the handle while pulling the power supply. Do not pull the power supply by the green catch. If you pull the green catch, the green catch may come off.

- ▶ Slide the new power supply unit into the empty slot until it clicks into place.

i Make sure that the power supply unit engages correctly in the slot and is locked in position.

This is the only way to prevent the power supply unit from sliding out of its mountings and being damaged during transportation.

- ▶ Connect the newly installed power supply unit with the power source.

8.1.2 Hot-plug disk drives

The disk drives which can be ordered for the PRIMERGY RX300 S6 are supplied already mounted in an installation frame so that defective disk drives can be replaced and new hard disk drives can be added during operation. The disk drive and installation frame together make up the disk drive module.



CAUTION!

- The disk drive must not be removed from the installation frame by anyone except a service technician.
- The disk drive modules (drives) must all be marked clearly so that they can be put back in their original places after an upgrade. If this is not done, existing data can be lost.
- The hot-plug function is only possible in conjunction with a corresponding RAID configuration.

Further information about the RAID configuration or RAID level can be found in the RAID controller documentation.

- Do not touch the circuitry on boards or soldered parts. Hold the metallic areas or the edges of the circuit boards.
- Before removing the unit, turn the power off and wait for about 30 seconds until the disk stops spinning completely.
- When the hard disk drive is starting up, you may hear a resonant noise for a while, but this does not mean a failure.
- Depending on the OS, you can configure the write cache settings for the disk drives. However, disable the write cache for use in this server. If the power failure should occur while the write cache is enabled, cached data may be lost.
- When disposing of, transferring, or returning a disk drive, wipe out the data on the drive for your own security.
- Rough handling of disk drives can damage the stored data. To cope with any unexpected problems, always back up important data. When backing up data to another disk drive, you should make backups on a file or partition basis.
- Be careful not to hit the disk drive or bring it into contact with metallic objects.
- Use the device on a shock and vibration free surface.

- Do not use the unit in extremely hot or cold locations, or locations with extreme temperature changes.
- Never attempt to disassemble a hard disk unit.

8.1.2.1 3.5-inch HDD module and dummy module

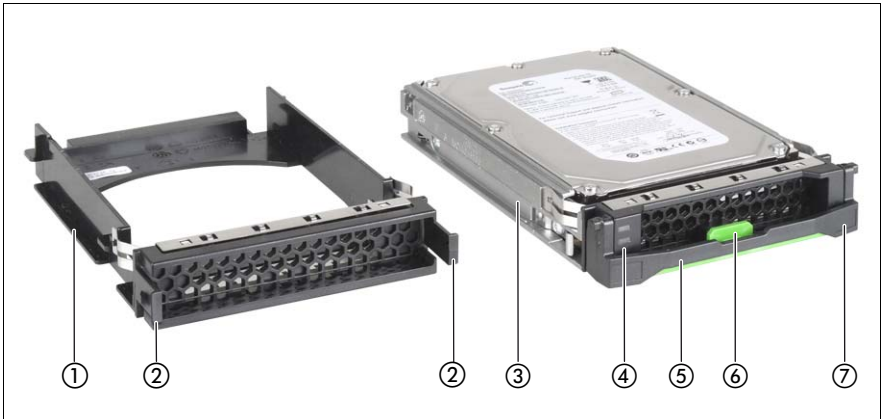

Figure 28: 3.5-inch HDD module and dummy module

1	Dummy module
2	Tabs for unlocking the dummy module
3	HDD module (installation frame with hard disk drive installed)
4	Indicators HDD Busy (LED green) HDD Fault (LED orange) For description see section "Hard disk drive indicators" on page 71.
5	Handle for locking and unlocking the HDD module
6	Button for locking and unlocking the handle
7	Recess for applying a sticker with the current drive name and drive size

8.1.2.2 2.5-inch HDD module and dummy module

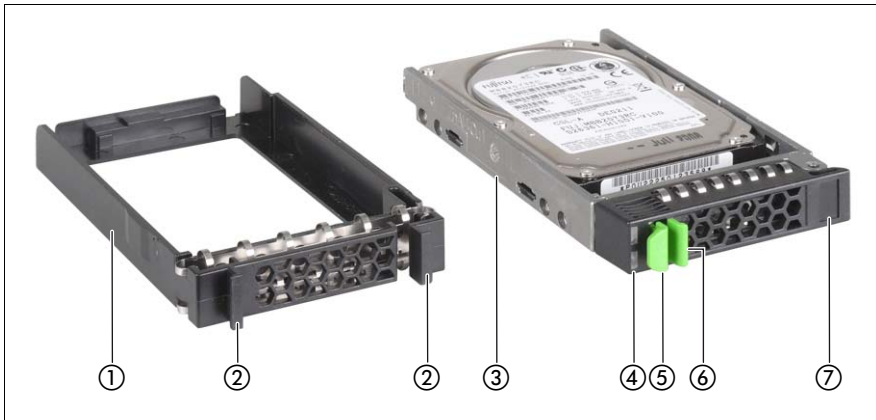

Figure 29: 2.5-inch HDD module and dummy module

1	Dummy module
2	Tabs for unlocking the dummy module
3	HDD module (installation frame with hard disk drive installed)
4	Indicators HDD Busy (LED green) HDD Fault (LED orange) For description see section "Hard disk drive indicators" on page 71.
5	Handle for locking and unlocking the HDD module
6	Button for locking and unlocking the handle
7	Recess for applying a sticker with the current drive name and drive size

8.1.2.3 2.5-inch SSD module



Figure 30: SSD module

1	Indicators Busy (LED green) Fault (LED orange) For description see section "Hard disk drive indicators" on page 71 .
2	Handle for locking and unlocking the HDD module
3	Button for locking and unlocking the handle
4	Recess for applying a sticker with the current drive name and drive size
5	SSD module (installation frame with SSD installed)

8.1.2.4 Handling drives and HDD/SSD modules

Drives incorporated in the HDD/SSD modules are highly sensitive electromagnetic devices and must be handled with great care. Incorrect handling can cause partial or total failure of the drives. These failures can result in data errors and to a loss of data or to total corruption of the drive.

Observe the following rules to prevent such problems occurring:

- Only store and transport HDD/SSD modules within the limits stipulated in the specification.
- When transporting HDD/SSD modules (even over short distances), always use the original packaging (ESD label).
- Never expose HDD/SSD modules to a temperature shock. Avoid the formation of condensation inside and on the outside of the drive.



CAUTION!

The HDD/SSD module must be acclimatized in its operating environment for an acclimatization time before it is started up for the first time.

Temperature difference (°C) (operating environment/ outside)	Minimum acclimatization time (hours)
5	3
10	5
15	7
20	8
25	9
30	10

Table 3: Acclimatization times for HDD/SSD modules

- Always set the HDD/SSD module down carefully, with the large surface facing downwards to prevent it from tipping over.

8.1.2.5 Removing/installing the dummy module

Free slots are provided with dummy modules. Remove the dummy module before installing an additional HDD module.

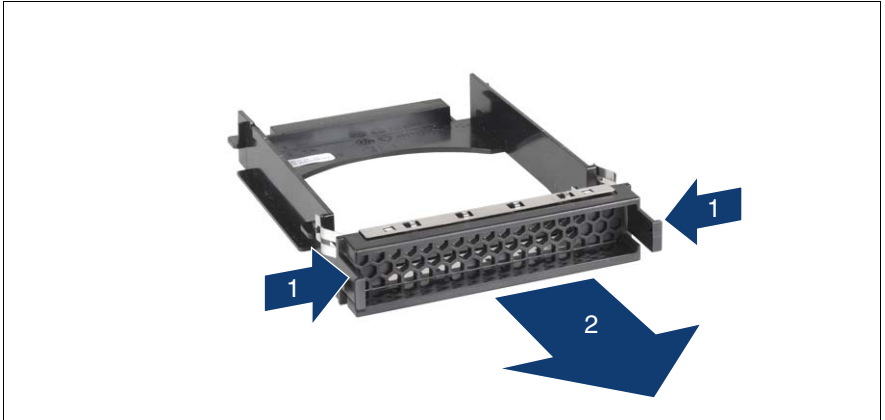

Figure 31: Removing/installing the dummy module (example: 3.5-inch dummy module)

- ▶ Press both tabs on the dummy module together until the locking mechanism disengages (1).
- ▶ Pull the dummy module out of the bay (2).

To install a dummy module, follow the same procedure in reverse order.



CAUTION!

Store the dummy module in a safe place. If you have removed a HDD module and do not install a new one in its place, put the dummy module back in its place for cooling, to comply with EMC regulations (regulations regarding electromagnetic compatibility), and for protection against fire. Ensure that the dummy module engages correctly in the bay.

8.1.2.6 Installing the disk drive module

Unlocking the disk drive module



Figure 32: Unlocking the 3.5-inch HDD and 2.5-inch HDD/SSD modules

- ▶ Release the locking mechanism by pressing the locking button (1).
- ▶ Push the handle of the disk drive module fully in the direction of the arrow (2).

The disk drive module is now unlocked.

Installing the disk drive module



Figure 33: Installing the 2.5-inch and 3.5-inch HDD/SSD modules

- ▶ Unlock the disk drive module as described in section "[Unlocking the disk drive module](#)" on page 106.
- ▶ Carefully push the disk drive module into the empty slot (1) until it stops.
- ▶ Push the handle as far as it will go in the direction of the arrow (2) until the locking mechanism is engaged.

8.1.2.7 Removing the disk drive module



CAUTION!

- Only remove a disk drive module during operation if the drive is not currently being accessed. Observe the control LEDs for the corresponding disk drive modules (see ["Hard disk drive indicators" on page 71](#)).
- Under no circumstances should you remove a disk drive module while the system is in operation if you are not sure whether the disk drive is operated by a RAID controller and belongs to a disk array.

A disk drive module can only be replaced during operation in conjunction with a corresponding RAID configuration.
- All disk drive modules (drives) must be uniquely identified so that they can be reinstalled in their original mounting locations later. If this is not done, existing data can be lost.

If you want to remove a disk drive module during operation, proceed as follows:

- ▶ If you want to remove a disk drive module that is not defective, the hard disk drive must first be set to "make available offline" via the software (RAID controller configuration software).
- ▶ Unlock the disk drive module as described in section ["Unlocking the disk drive module" on page 106](#).
- ▶ Pull the disk drive module out a few centimeters.
- ▶ Wait for at least 60 seconds.



This period is necessary for the RAID controller to recognize that a disk drive module has been removed and for the hard disk drive to come to a stop.

- ▶ Pull the disk drive module out completely.
- ▶ Install the new disk drive module, as described in ["Installing the disk drive module" on page 106](#).



CAUTION!

If you have removed a disk drive module and do not install a new one in its place, put the dummy module back in its place for cooling, to comply with EMC regulations (regulations regarding electromagnetic compatibility), and for protection against fire. Ensure that the dummy module engages correctly in the bay.

8.1.3 Replacing the hot-plug fan modules

**CAUTION!**

Please observe the safety information in [chapter "Important information" on page 31](#).

In order to replace a defective fan, it is necessary to remove the housing cover, because the fans are not directly accessible (see [section "Opening/closing the housing" on page 119](#)).

**CAUTION!**

The housing cover must be replaced as soon as possible for purposes of cooling, to comply with EMC regulations (regulations regarding electromagnetic compatibility) and to prevent fires. The housing cover must not remain open for longer than 5 minutes.



The PRIMERGY RX300 S6 server with a 48 V DC power supply is equipped with 10 fans. Do not remove one fan without replacing it.

The server is equipped with five separate hot-plug fan modules. The redundant fan configuration allows one fan to fail and the system still works. To ensure the redundancy of the fan system the faulty fan has to be replaced immediately.

A predicted fan fault is reported by the Global Error indicator lighting up on the front and rear of the server. When the housing cover is open, the faulty fan can be identified by the corresponding LED ([figure 34 on page 110](#)) and can be replaced while the system is running.

To ensure the redundancy of the fan system the faulty fan has to be replaced immediately.

8.1.3.1 Replacing the fan modules

- ▶ Remove the housing cover (see [section "Opening/closing the housing" on page 119](#)).



Figure 34: Arrangement of fans and the corresponding indicators

- ▶ Use the indicator (lights up orange) to identify the defective fan. The position of the indicators is shown by arrows in [figure 34](#).

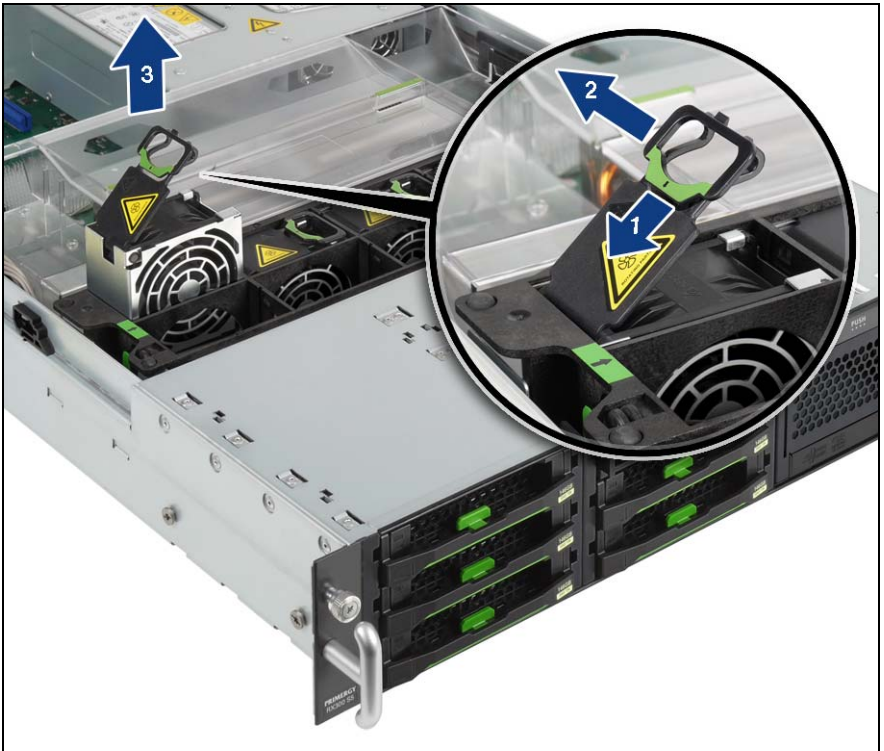

Figure 35: Removing the fans (example: fan 1)

- ▶ Pull the green lever on the fan handle in the direction of the arrow (1) to release the locking mechanism, and pull out the handle (2).
- ▶ Pull the fan out of its mounting location by its handle.
- ▶ Set the fan down on the outside of the server.



CAUTION!

Never set a removed/defective fan down inside the server. Risk of short circuit!

- ▶ Open the green handle on the new fan, place the fan in the fan box and press the handle together to engage the locking mechanism.



The new fans are measured with explicit commands in Server Management. Depending on the result, the corresponding LED (see [figure 34 on page 110](#)) is set to dark (fan is in order) or orange flashing (failure) or orange lighting (prefailure).

- ▶ Return the housing cover to its position (see [section "Opening/closing the housing" on page 119](#)).

8.2 Non-hot-plug components



CAUTION!

- The actions described in this section may only be performed by personnel with the appropriate technical training. (The device can be seriously damaged if it is opened without authorization or if repairs are attempted by untrained personnel.)
- Before installing/removing memory to/from the server, turn off the server, all peripheral devices, and any other connected devices. Also unplug all power cables from the outlet. Failure to do so can cause electric shock.
- The circuit boards and soldered parts of internal options are exposed and can be damaged by static electricity. Before handling them, first touch a metal part on the server to discharge static electricity from your body.
- Do not touch the circuitry on boards and soldered parts. Hold the metallic areas or the edge of the circuit boards.
- Do not install unauthorized third party memory modules. Doing so may cause electric shock, a fire, or failures.
- Wait for a sufficient period of time after server shutdown before installing or removing memory modules. Failure to do so may cause burns. When installing or removing memory modules, make sure to remove the screws at the specified points only. Failure to do so may cause injury. It may also cause failures.
- Touch only the specified part of the printed circuit board. Failure to do so may cause injury. It may also cause failures.
- Do not insert and remove memory modules repeatedly. Doing so may cause failures.

- If the memory module has not been correctly inserted, it may cause a fire. Insert the memory module with attention to its direction.
- If a memory module is installed and you pull the lever strongly outwards, the memory module pops up. Doing so may cause a device failure.
- Please observe the safety information in [chapter "Important information" on page 31](#).

If a defective non-hot-plug component is detected (further information can be found in [chapter "Starting up and operation" on page 67](#) and the "ServerView Suite Local Service Concept - LSC" manual on the ServerView Suite DVD 2), proceed as follows:

- ▶ Exit all applications and shut down the server properly (see section ["Switching the server on and off" on page 79](#)).
- ▶ Pull all power connectors out of the power outlets.
- ▶ Open the server (see section ["Opening/closing the housing" on page 119](#)).
- ▶ Press the Indicate CSS button on the system board (see the technical manual for the system board D2619-N).

The PRIMERGY Diagnostic LED of the defective CSS component lights up orange, thereby indicating which CSS component (memory module, fan or expansion card) on the system board must be replaced (see technical manual for the system board D2619-N).

8.2.1 Replacing a memory module

- ▶ Remove the housing cover (see [section "Opening/closing the housing" on page 119](#)).

The slots for the memory modules can be found under the air duct.

8.2.1.1 Removing the air duct



Figure 36: Removing the air duct



If you have installed an SAS/SATA RAID controller with a BBU: pay attention to the BBU cable when lifting off the air duct! If you want to remove the air duct from the server completely, first disconnect the BBU cable.

- ▶ Take hold of the air duct by the green touch points, and lift it up and off.

8.2.1.2 Removing a defective memory module

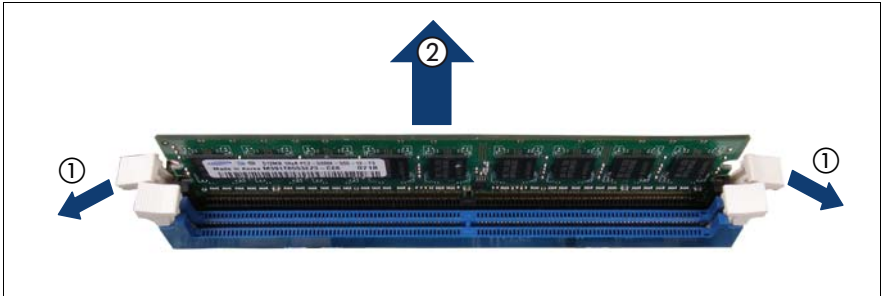

Figure 37: Removing a memory module

- ▶ Press the holders on either side of the mounting location concerned outward (1).
- ▶ Pull the memory module out of the slot (2).

8.2.1.3 Installing a new memory module



CAUTION!

Please note the equipping rules in the technical manual for the system board D2619-N.

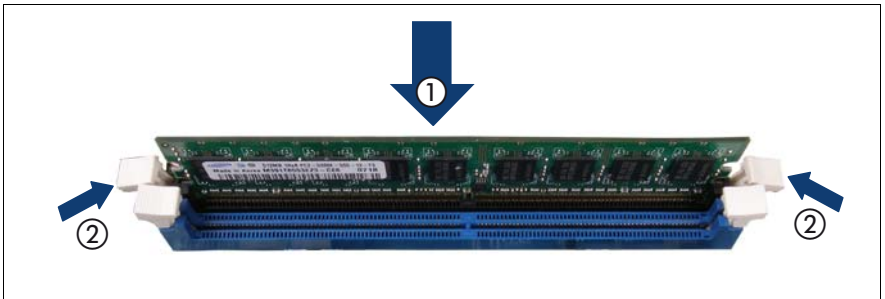

Figure 38: Inserting a memory module

- ▶ Carefully press the memory module into the slot (1) until the fastening tabs on both sides of it engage (2).
- Pay attention to the plug coding.

8.2.1.4 Replacing the air duct and closing the server

- ▶ Insert the air duct in the server.

If an SAS/SATA RAID controller is installed and you disconnected the BBU cable when you removed the air duct:

- ▶ Connect the BBU cable that you disconnected previously.
- ▶ Return the housing cover to its position (see [section "Opening/closing the housing" on page 119](#)).

8.2.2 Replacing an expansion card

- ▶ The illuminated orange indicator shows which is the slot for the defective expansion card.



Figure 39: Removing the expansion card

- ▶ If necessary, disconnect the cables from the defective expansion card.
- ▶ Loosen the screw on the rear cover (see circle).
- ▶ Remove the defective expansion card from the server (see arrows).



For the installing order see the configurator provided for the RX300 S6:

http://ts.fujitsu.com/products/standard_servers/index.html
(for the EMEA market)

<http://primeserver.fujitsu.com/primergy/system.html> for the Japanese market



Figure 40: Installing an expansion card

- ▶ Carefully press the new expansion card into the correct slot on the system board (arrows) until it clicks into place.
- ▶ Secure the expansion card with the screw (circle).
- ▶ If necessary, reconnect the cables to the expansion card and other components.
- ▶ Return the housing cover to its position (see [section "Opening/closing the housing" on page 119](#)).

8.3 Opening/closing the housing



CAUTION!

The safety instructions in chapter "[Important information](#)" on [page 31](#) must be obeyed without fail.



CAUTION!

The housing cover must be replaced as soon as possible for purposes of cooling, to comply with EMC regulations (regulations regarding electromagnetic compatibility) and to prevent fires. The housing cover must not remain open for longer than 5 minutes.

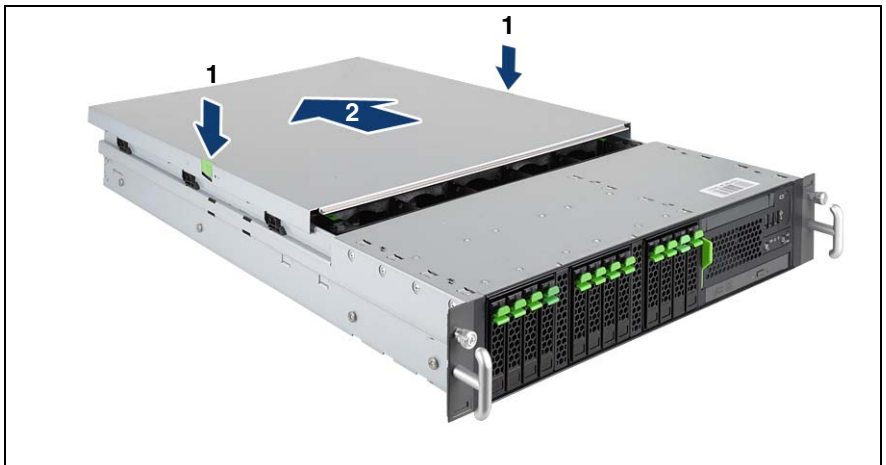

Figure 41: Opening the housing

- ▶ Press the two locks in the direction of the arrow (1) and remove the cover (2).
- ▶ To close it, put the cover on the housing and pull it forwards until the cover closes and the locking mechanism is engaged.

9 Appendix: server specification

This section explains the specifications for the server. The specifications for this server are liable to be updated without any notice. Please be forewarned.

System Board

System board type	D2619-N
Chipset	Intel 5520

Processor

Processor quantity and type	1 or 2 Intel Xeon processors
-----------------------------	------------------------------

Memory Modules Configuration

Memory slots	18
Memory slot type	DDR3 (RDIMM, UDIMM, LV-RDIMM, LV-UDIMM)
Memory capacity (min. - max.)	2 GB - 192 GB
Memory protection	Advanced ECC; Memory Scrubbing; SDDC (Chipkill™); Hot-spare memory support Memory Mirroring support
Memory notes	Memory Mirroring with at least 2 identical modules per CPU (black slot in channel A+B or D+E), Hot-spare Memory with at least 3 identical modules per CPU (black slot in every channel)

Interfaces

USB connectors	10 x USB 2.0 (3x front, 4x rear, 2x internal for backup devices plus 1x USB stick or UFM)
Graphics (15-pin)	2 x VGA (thereof 1x front optional)
Serial 1 (9-pin)	1 x serial RS-232-C, usable for iRMC S2 or system or shared

Serial 2 (9-pin)	1 x serial RS-232-C
LAN / Ethernet (RJ-45)	2 x Gbit/s Ethernet
Service LAN (RJ45)	1 x dedicated service LAN connector for iRMC S2 (10/100 Mbit/s) Service LAN traffic can be switched to shared onboard Gbit LAN port

Onboard or integrated controllers

RAID Controller	Modular RAID 0/1 controller with "Integrated Mirroring Enhanced" (SAS IME) for SAS1.0. RAID levels 0, 1 and 1E are supported for internal hard disk drive configurations. For the Japanese market only RAID level 1 is supported for internal hard disk drive configurations.
	Modular RAID 0/1 controller with "MegaRAID functionality" (SAS MegaRAID) for SAS1.0 and SAS2.0. RAID levels 0, 1,10 and 1E are supported for internal hard disk drive configurations.
	Modular RAID 5/6 controller with "MegaRAID functionality" (SAS MegaRAID) for SAS1.0 and SAS2.0. RAID levels 0, 1, 10, 1E, 5, 50, 6 and 60 are supported for internal hard disk drive configurations.
SATA Controller	ICH10B, 2 x SATA channel for DVD+backup
Remote Management Controller	Integrated Remote Management Controller (iRMC S2, 32 MB attached memory incl. graphics controller), IPMI 2.0 compatible
Trusted Platform Module (TPM)	Infineon / separate module; TCG V1.2 compliant (option)

Slots

PCI-Express 2.0 x4 (mech. x8)	5 x low profile from 4 PCIe slots each two wired x4 slots can be combined to one wired x8 slot one PCIe-2 slot is occupied with one of two possible modular RAID controllers
PCI-Express 2.0 x8	2 x low profile

Slot notes	slot 5 and 7 are notched at the right side and thus also usable for x16 cards (operating x8, slot 5 only if neighbor slot is empty)
------------	---

Drive bays

Hard disk bay configuration	6x 3.5-inch, for SAS / SATA or 8x 2.5-inch, 12x 2.5-inch for SAS/SATA/SSD optional
Accessible drive bays	1 x 5.25/0.5-inch for CD-RW/DVD 1 x 3.5/0.5-inch for ServerView Local Service Panel or Local Service Display 1 x 3.5/1.6-inch for backup devices (occupies 2x 3.5-inch HDD for basic unit 6x 3.5-inch)
Notes accessible drives	all possible options described in relevant system configurator

Operating Panel

Operating buttons	On/off switch
	NMI button
	Reset button
Status LEDs	System status (orange / yellow)
	Identification (blue)
	Hard disks access (green)
	Power (orange / green)
Status LED at system rear side:	System status (orange / yellow)
	Identification (blue)
	LAN connection (green)
	LAN speed (green / yellow)
Service displays (optional):	ServerView Local Service Panel (LSP)
	ServerView Local Service Display (LSD)

Weight

Weight	up to 25 kg
Weight notes	Weight may vary depending on actual configuration
Rack mounting kit	Rack mounting kit as option

Dimensions (Base unit specific)

Rack (W x D x H)	482.4 x 770 (with handles) x 85.9 mm
Mounting Depth Rack	735 mm

Environmental

Noise emission	Measured according to ISO 7779 and declared according to ISO9296
Sound pressure (LpAm)	45 dB(A) (idle) / 45 dB(A) (operating)
Sound power (LWA _d ; 1B = 10dB)	6.2 B (idle) / 6.2 B (operating)
Operating ambient temperature	10 - 35 °C
Operating relative humidity	10 - 85 % (non condensing)

Electrical values

	AC power supply	DC power supply
Power supply configuration	Base unit specific: 1x hot-plug power supply or 2x hot plug power supply for redundancy	
Max. output of hot-plug power supply	800 W	
Rated voltage range	100 V - 240 V	40.5 V - 57 V
Rated frequency range	50 - 60 Hz	DC
Rated current	max. 8.0 A – 3.5 A / 100 V - 240 V	23.8 A - 16.4 A / 40.5 V - 57 V

Index

3rd party rack
installing in 57
requirements 48

A

accessible drives
DVD 19
DVD writer 19
magnetic tape drive 19
acclimatization time 45, 104
Advanced Video Redirection 22
ASR&R 21
availability 20
AVR 22

B

batteries 35
BIOS
security functions 87
BIOS update 24

C

cable strain relief 64
cable tie 64
cables
connecting 66
disconnecting 66
CE marking 27, 39
Chipkill 20
Class A Compliance Statement 40
cleaning
keyboard 85
monitor 85
mouse 85
server 85
closing
housing 119
configuration
server 82
connecting cables 66

connectors

COM1 60, 61
service LAN connector 60, 61
shared LAN connector 60, 61
system LAN connector 60, 61
USB connector 60, 61
video connector 60, 61

consumables 43

control panel 67

controls 67

cooling

fans 20

correcting faults 89

CPU

fans 20

CSS indicator 67, 70, 74

D

data protection 87

data security 20

DataCenter rack
requirements 47

date, incorrect 92

delivery note 29, 46

devices

connecting to server 60

dimensions 28

disconnecting cables 66

disposal, devices 44

drive

defective 93

indicators 71

“dead” 92

drive module

acclimatization time 104

dummy module, HDD module 105,
108

DVD drive activity indicator 67, 71

E

ECC 20

-
- EDC 20
 - electrical data 26
 - electromagnetic compatibility 27, 39
 - electrostatic-sensitive devices (ESD) 38
 - EMC directive 27
 - EMC regulations 105, 108
 - ENERGY STAR 39
 - environment class 28
 - environmental conditions 28
 - environmental protection 43
 - error
 - drifting display on monitor 91
 - drive defective 93
 - drive “dead” 92
 - incorrect date 92
 - incorrect time 92
 - no display on monitor 91
 - power-on indicator does not light 89
 - screen remains blank 90
 - screen shows flickering stripes 91
 - server switches itself off 90
 - system does not boot 92
 - Error Correcting Code 20
 - Error Detection Code 20
 - error message on screen 93
- F**
- fan
 - installing/removing 109
 - removing 110
 - fans
 - CPU 20
 - power supply unit 20
 - system 20
 - fault
 - drifting display on monitor 91
 - drive defective 93
 - incorrect date 92
 - incorrect time 92
 - no display on monitor 91
 - screen remains blank 90
 - screen shows flickering stripes 91
 - system does not boot 92
 - FCC statement 40
 - features 14
 - flash EPROM 24
- G**
- Global Error indicator 67, 69, 73
 - graphics card 62
- H**
- hard disk activity indicator 67, 69
 - hard disk drive 17
 - indicator 71, 72
 - installation frame 100
 - online replacement 108
 - HDD module 100
 - hot-plug 21
 - installation frame 106
 - installing 106
 - HDD/SSD drives
 - handling 104
 - hot-plug
 - fan 109
 - power supply unit 20, 96
 - hot-plug power supply unit 63
 - hot-spare memory
 - memory module 20
 - housing
 - closing 119
 - opening 119
- I**
- ID button 67, 68
 - ID card
 - product name 46
 - serial number 46
 - ID indicator 67, 70, 74
 - IME 18, 82
 - indicator
 - power supply unit 76, 77
 - indicators
 - CSS 67, 70, 74

-
- DVD drive activity [67, 71](#)
 - Global Error [67, 69, 73](#)
 - hard disk activity [67, 69](#)
 - ID [67, 70, 74](#)
 - on power supply unit [76, 77](#)
 - on the server [67](#)
 - operation [67](#)
 - system error [69, 73](#)
 - information, additional [13](#)
 - installing
 - server [47, 55](#)
 - installing in
 - 3rd party rack [57](#)
 - PRIMECENTER Rack [50](#)
 - installing in the rack, notes [42](#)
 - installing the operating system [84](#)
 - Integrated Mirroring Enhanced [18, 82](#)
 - integrated Remote Management Controller [22](#)
 - iRMC S2 [22](#)
 - L**
 - labels [44](#)
 - laser information [37](#)
 - light emitting diode (LED) [37](#)
 - lithium battery [35](#)
 - Low Voltage Directive [27, 39](#)
 - M**
 - magnetic tape drive [19](#)
 - mains voltage
 - connecting server [63](#)
 - management LAN connector [22](#)
 - meaning of the symbols [25](#)
 - MegaRAID [18, 82](#)
 - Memory Mirroring [21](#)
 - memory module
 - hot-spare memory [20](#)
 - memory scrubbing [20](#)
 - monitor
 - display drifts [91](#)
 - no display [91](#)
 - N**
 - NMI button [67, 68](#)
 - noise level [28](#)
 - notational conventions [25](#)
 - O**
 - On/Off button [67, 68](#)
 - online replacement [108](#)
 - opening
 - housing [119](#)
 - operation [67](#)
 - overload [23](#)
 - P**
 - packaging [43, 46](#)
 - PCI SAS controller, configuring [84](#)
 - PDA [21, 23](#)
 - ports [60, 67](#)
 - USB [19](#)
 - power supply
 - redundant [20](#)
 - power supply unit
 - adding [97](#)
 - cable strain relief [64](#)
 - cable tie [64](#)
 - dummy module [97](#)
 - fans [20](#)
 - hot-plug [20, 96](#)
 - indicators [76, 77](#)
 - redundant [63](#)
 - replacing [98](#)
 - wide range [20](#)
 - power supply, redundant [63](#)
 - power-on indicator [67, 69](#)
 - does not light [89](#)
 - PRIMECENTER Rack
 - installing in [50](#)
 - requirements [47](#)
 - PRIMERGY Diagnostic LED [24](#)
 - product name [46](#)
 - property protection [87](#)

-
- R**
- rack
 - requirements 47
 - RAID controller is not configured for this drive 93
 - recycling devices 44
 - redundancy
 - fans 20
 - power supply 20
 - regulations and standards 27
 - Remote Storage 22
 - removing
 - fan 110
 - server 47
 - requirements
 - 3rd party rack 48
 - DataCenter rack 47
 - PRIMECENTER Rack 47
 - reset button 67, 68
 - return of devices 44
 - routing
 - cables 54
- S**
- safety instructions 31
 - safety standards 27
 - SAS IME controller 18
 - SAS MegaRAID controller 18
 - SAS/SATA RAID controller 18
 - configuring 82
 - saving energy 43
 - screen
 - error message 93
 - flickering 91
 - remains blank 90
 - shows flickering stripes 91
 - serial number 46
 - server
 - closing the housing 119
 - configuration 24
 - configuring 82
 - connecting external devices 60
 - connecting mains voltage 63
 - control panel 67
 - correcting faults 89
 - data protection 87
 - dimensions 28
 - electrical data 26
 - environmental conditions 28
 - fitting in rack 47
 - hot-plug power supply unit 96
 - indicators 67
 - installing 47, 55
 - LAN connector 60, 61
 - NMI button 67
 - noise level 28
 - opening the housing 119
 - operation 67
 - ports 60
 - power on indicator 69
 - product name 46
 - property protection 87
 - removing 47
 - routing cables 54
 - serial number 46
 - service 24
 - shared LAN connector 60, 61
 - startup 67
 - switches itself off (error) 90
 - switching off 79
 - switching on 79
 - technical data 26
 - transport 41
 - troubleshooting 89
 - unpacking 46
 - server management 23
 - ServerView Installation Manager 24, 83
 - ServerView Operations Manager 23
 - supported functions 23
 - ServerView Remote Management 25
 - service
 - PRIMERGY Diagnostic LED 24
 - server 24
 - touch point 24
 - service LAN connector 22, 60, 61
 - slimline optical drive 19

- startup
 - server [67](#)
- support bracket [51](#)
- switch off time, defining [80](#)
- switch on time, defining [80](#)
- switching off, server [79](#)
- switching on, server [79](#)
- system
 - fans [20](#)
- system board [15](#)
 - PRIMERGY Diagnostic LED [24](#)
- system does not boot [92](#)
- system fans
 - redundant [20](#)

T

- target group [11](#)
- technical data [26](#)
- time, incorrect [92](#)
- tips [89](#)
- touch point
 - service [24](#)
- TPM [15](#)
- transport damage [29, 46](#)
- transporting the server [41](#)
- troubleshooting [89](#)
- troubleshooting, server [89](#)
- Trusted Platform Module [15](#)

U

- unpacking, server [46](#)
- USB connector [60, 61](#)
- USB port [19, 67](#)

V

- video connector [60, 61](#)

